

VTT Technical Research Centre of Finland

AI Operator – A virtual guy for running an industrial process

Lappalainen, Jari T.J.; Linnosmaa, Joonas; Rainio, Kari; Papakonstantinou, Nikolaos;
Tahkola, Mikko

Published: 26/11/2019

Document Version
Publisher's final version

[Link to publication](#)

Please cite the original version:

Lappalainen, J. T. J., Linnosmaa, J., Rainio, K., Papakonstantinou, N., & Tahkola, M. (2019). *AI Operator – A virtual guy for running an industrial process*. Poster session presented at AI Day 2019, Espoo, Finland.



VTT
<http://www.vtt.fi>
P.O. box 1000FI-02044 VTT
Finland

By using VTT's Research Information Portal you are bound by the following Terms & Conditions.

I have read and I understand the following statement:

This document is protected by copyright and other intellectual property rights, and duplication or sale of all or part of any of this document is not permitted, except duplication for research use or educational purposes in electronic or print form. You must obtain permission for any other use. Electronic or print copies may not be offered for sale.

AI Operator – Accelerating the Pilot to Full-scale Process Development

Joonas Linnosmaa, Kari Rainio, Nikolaos Papakonstantinou, Mikko Tahkola, Jari Lappalainen
VTT Technical Research Centre of Finland Ltd

Challenge in process industry – From laboratory to production scale

Scaling up new processes is expensive. There is an exponential cost increase at each scale-up phase. Thus, the risks for investors get higher and projects might get cancelled. At the same time, there is a demand for new and innovative products. Proper fault management is crucial in the scale-up phase and lowers the risks whilst increasing safety and avoiding downtime.

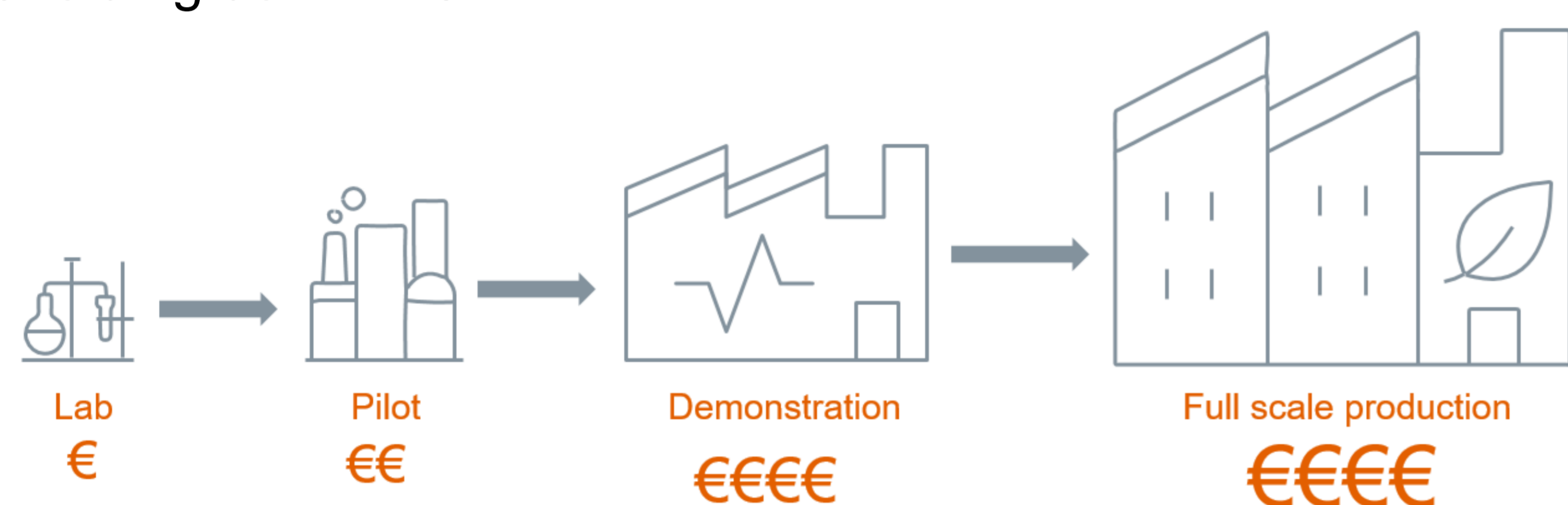

Figure 1. Costs in process scale-up from laboratory to full scale production increase at each phase.

AI Operator – The key idea

AI is a key element in Industry 5.0, enabled by plant digitalization. AI has novel potential as a design and operation support tool and in handling fault situations on plant level. The key idea in AI Operator concept is to perform exhaustive simulations to learn how to act. The AI Operator tries to learn how to control a simulation model of a process under normal and fault conditions. The results indicate whether the plant design is sound or not. If the AI Operator is not able to learn, it might indicate that there is a design flaw, which can be fixed already in the design phase. The AI Operator makes use of an AI method called reinforcement learning.

Reinforcement learning – Adaptive agent

Reinforcement learning is a computational goal-oriented method for learning how to act in an environment. The method includes one or multiple learning *agents*. In the beginning, the agent does not know anything about the environment, but it has ways to observe its state. The agent also has the possibility of carrying out *actions* that has an impact on the environment's state. By giving the agent a goal in form of a *reward function*, it can evaluate and learn by trial-and-error which actions were good, i.e. lead to a state that maximize the reward function. [1]

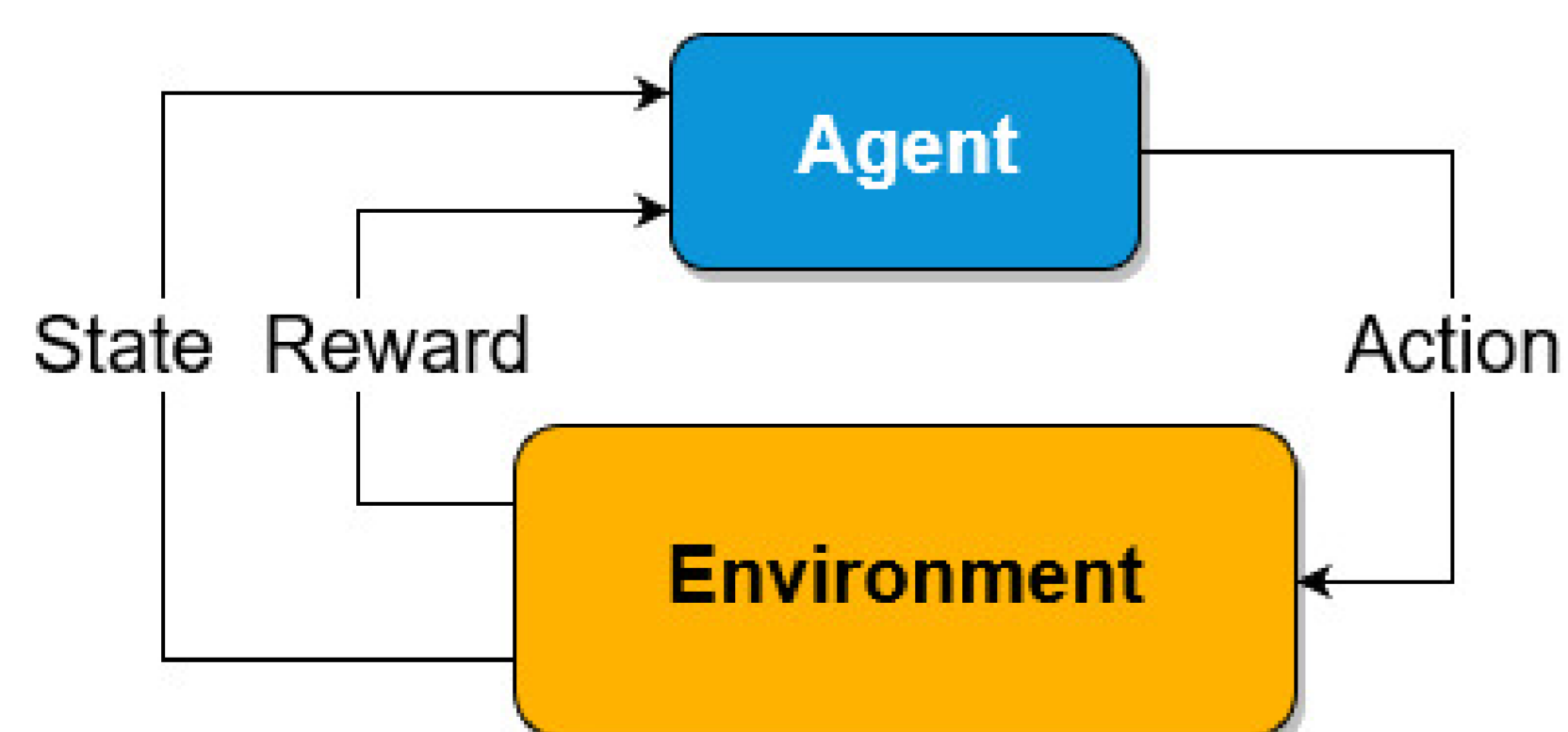

Figure 2. The agent does actions in reinforcement learning to affect the environment. The resulting state of the environment specifies the reward.

In order to find a good solution and achieve a high reward, the agent needs to be able to explore how different actions change the environment, but also to exploit the knowledge from previous trials. [1]

[1] Sutton R. & Barto A, 2018. Reinforcement learning – An introduction. 2nd edition. MIT Press, Cambridge, Massachusetts, London, England. ISBN: 978-0-262-19398-6.

Case study – Applying reinforcement learning to learn how to operate a process

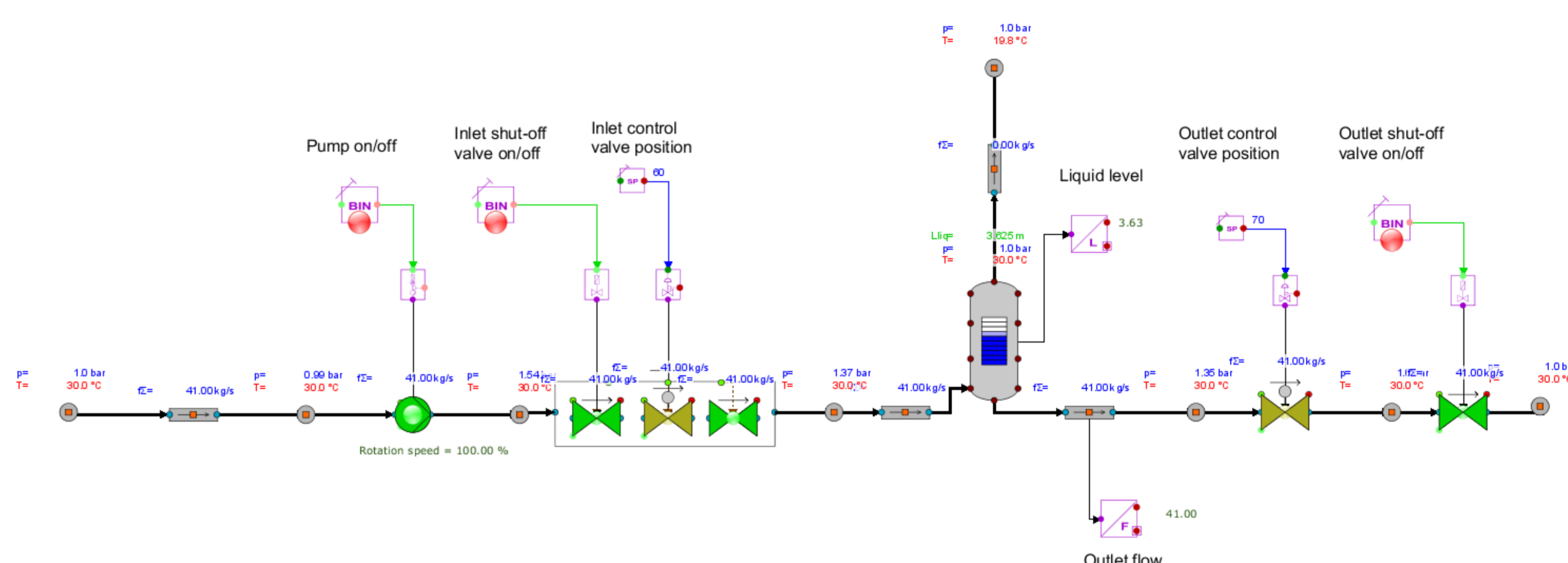

Figure 3. Water tank process model used in the case study.

Water tank process shown in Figure 2 was modelled in Apros[®].

- The AI Operator used the Q-learning algorithm to learn how to process this plant.
- Rewards for all state-action pairs are stored in master Q-table, which is updated by multiple agent-environment pairs to speed up learning.
- The target was to start the process from shutdown conditions and get the liquid level to 3m and outlet mass flow to 40 kg/s.
- The Operator can adjust the pump and all four valves.

The AI Operator was allowed to change the valve positions and turned the pump on or off three times – in the beginning, after 1 minute and after 2 minutes of simulation. It learned a good way to start-up the process in 20 000 trials. This took ~2.5 days of wall time on a single computer.

Benefits

- Scaling up new processes is faster.
- Development projects are not cancelled due to risks and uncertainty.
- A plant simulation model is built usually in the design phase, so the additional cost of training an AI Operator is small.
- The insight gained from the AI Operator is invaluable – The AI Operator offers early safety assessment and confidence to the current plant design before scaling up.

Conclusions

- Reinforcement learning can be applied to learn how to operate a process simulation model.
- The agent was able to learn how to start-up a process and reach target conditions.
- High number of simulations are required in the learning process, leading to long computation time. This can be overcome by parallelising the learning process.
- We are working towards optimizing the learning and more complex models