



This document is downloaded from the  
VTT's Research Information Portal  
<https://cris.vtt.fi>

**VTT Technical Research Centre of Finland**

## **Software Defined Radio Based Phase Meter for Frequency Metrology**

Hanhijärvi, Kalle; Wallin, Anders

*Published in:*  
XXXV Finnish URSI Convention on Radio Science

Published: 01/01/2019

*Document Version*  
Publisher's final version

*License*  
CC BY

[Link to publication](#)

*Please cite the original version:*  
Hanhijärvi, K., & Wallin, A. (2019). Software Defined Radio Based Phase Meter for Frequency Metrology. In *XXXV Finnish URSI Convention on Radio Science: Programme and Proceedings* International Union of Radio Science URSI. <https://www.ursi.fi/2019/Papers/Hanhijarvi.pdf>



VTT  
<http://www.vtt.fi>  
P.O. box 1000FI-02044 VTT  
Finland

By using VTT's Research Information Portal you are bound by the following Terms & Conditions.

I have read and I understand the following statement:

This document is protected by copyright and other intellectual property rights, and duplication or sale of all or part of any of this document is not permitted, except duplication for research use or educational purposes in electronic or print form. You must obtain permission for any other use. Electronic or print copies may not be offered for sale.

# Software Defined Radio Based Phase Meter for Frequency Metrology

Kalle Hanhijärvi<sup>(1)</sup>      Anders Wallin<sup>(1)</sup>

<sup>(1)</sup>VTT Technical Research Centre of Finland Ltd

Centre for Metrology MIKES

P.O. Box 1000, 02044 VTT

Tekniikantie 1, 02150 Espoo

Finland

kalle.hanhijarvi@vtt.fi

## Abstract

A software defined radio based phase meter for frequency metrology is presented. By using dual channel digitization, common mode non-idealities of the instrument are minimized. Baseline phase instability of the instrument was measured by using a hydrogen maser 100 MHz output as a reference. Downsampling the phase data from 1 MS/s to 1 S/s reduces the measured noise floor to an Allan deviation of  $2 \cdot 10^{-14}$  at an averaging time of 1 s in a bandwidth of 0.5 Hz.

## 1 Introduction

Traditional high-resolution phase or frequency measurement devices are commonly based on the Dual Mixer Time Difference (DMTD) method [1]. In the DMTD method two frequencies to be compared,  $f_1 \approx f_2$ , are down-mixed with a slightly frequency offset local-oscillator at frequency  $f_{LO} = f_1 - \Delta f$ . The resulting low-frequency (commonly 1-100 Hz) IF signals  $IF_1/IF_2$  are then amplified/filtered, and the time interval between zero-crossings are measured. Time intervals between zero-crossings of  $IF_1/IF_2$  are multiplied by the heterodyne gain  $f_1/\Delta f$ , for example  $10^7$  for a measurement of 10 MHz signals with  $\Delta f = 1$  Hz.

However, the analog DMTD method suffers from several drawbacks. First, a frequency offset LO source is required, with similar short-term stability as the signals being measured. Second, the DMTD is inflexible in that it is built for measuring only one reference frequency (e.g. 10 MHz) and cannot measure other frequencies. Third, it suffers from instabilities in the analog components used, such as mixers, amplifiers, filters, and zero-crossing detectors.

For these reasons, the direct digital phase meter technique has recently gained popularity [2-4]. Here the measured signals are digitized at a high sample rate (compared to the signal frequency) and the signal-processing steps of the DMTD are performed numerically. The digital approach generates the LO-signal for down-mixing numerically and thus allows a flexible input-frequency. Signal processing steps after digitalization do not suffer from temperature or voltage related instabilities, as do analog components.

We show how a COTS software defined radio platform and custom GNURadio software can be used for frequency metrology of 100 MHz reference signals from active hydrogen maser clocks.

## 2 Experimental setup

A schematic of the direct digital phase meter approach is shown in Figure 1. We use an Ettus B210 software defined radio featuring an Analog Devices AD9361 RF front end and a Xilinx Spartan6 FPGA for high speed digital downconversion (DDC), finite impulse response filtering (FIR) and decimation (DEC). We use the stock firmware on the B210, which uses CORDIC for DDC. Further low-pass filtering and decimation is performed on a host PC running GNURadio.

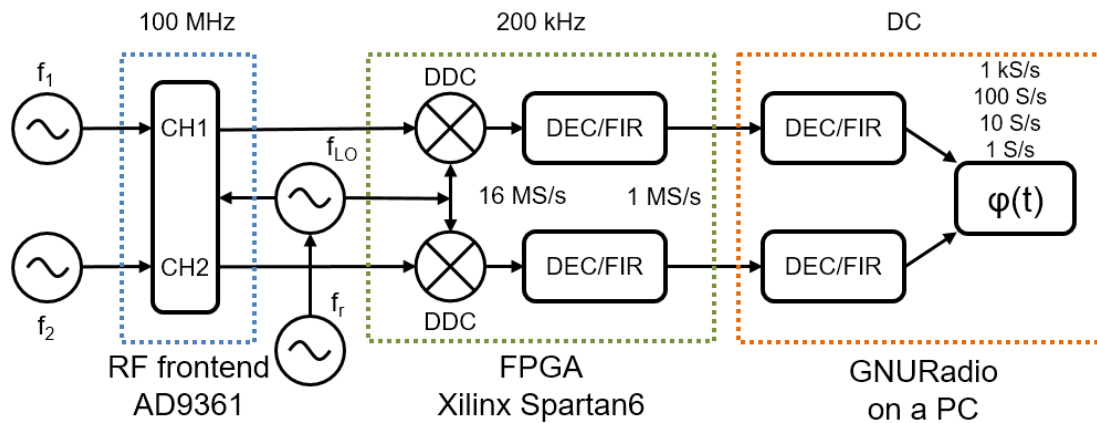

Fig 1: Software defined radio hardware and software for frequency metrology using the digital direct phase meter approach. The top frequencies indicate the signal baseband frequency at each stage of signal processing chain.

### 3 Results

We characterized the baseline performance of the phase meter by splitting a 100 MHz maser output to both inputs and measuring the phase difference between the channels. The measured phase was anti-alias filtered and decimated to 100 S/s, 10 S/s and 1 S/s. Overlapping Allan deviation (OADEV) of the decimated data is shown in Fig. 2. OADEV for the 1 S/s decimated data at one second, in a bandwidth of 0.5 Hz, gives a measurement instability of  $2 \cdot 10^{-14}$ , an improvement over  $7 \cdot 10^{-14}$  reported for a digital DMTD [3] or  $5.6 \cdot 10^{-14}$  for an analog DMTD [1].

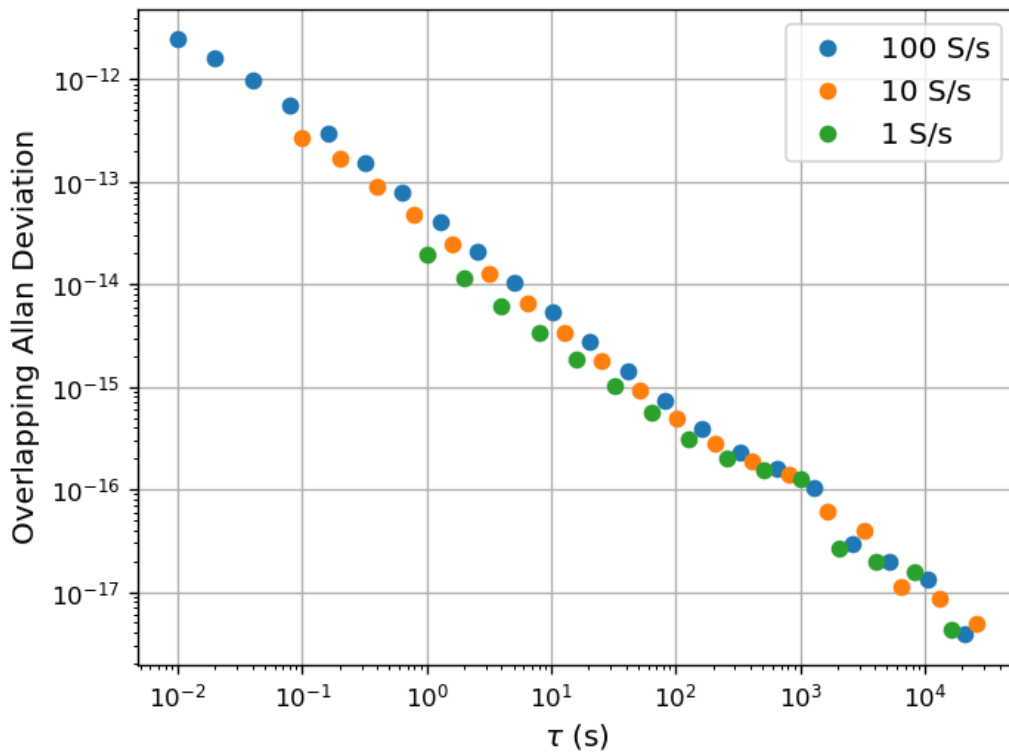

Fig. 2: Overlapping Allan deviation of the dual channel measurement of the 100 MHz maser output

Hydrogen masers exhibit very predictable linear aging of frequency. A frequency synthesizer is commonly used to steer the frequency output of the maser to correct for the linear drift. We measured the phase difference between an active hydrogen maser 100 MHz output and the output of a custom-designed frequency synthesizer [5] used to correct for the frequency drift. Fig. 3 shows the measured phase. A linear trend corresponding to a constant frequency offset has been removed from the data. The parabolic shape is caused by the linear frequency correction being applied by the synthesizer. A parabolic fit to the data in Fig. 6 gives a fractional frequency drift of  $2.02 \cdot 10^{-15}$  1/day, which agrees well with the frequency synthesizer setting. Note that conventional counters (e.g. Keysight 53230A) have random instabilities at the level of 10 ps or more, and would not resolve the maser/synthesizer frequency drift in a similar measurement.

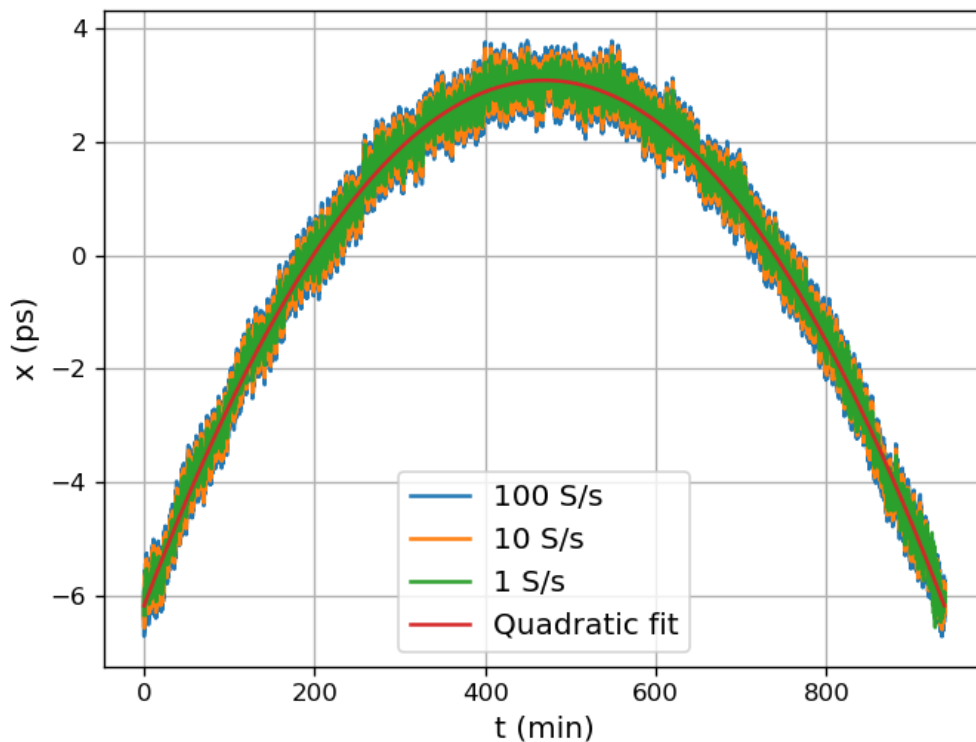

Fig. 3: Linear residual of the time error given by the phase difference between active hydrogen maser 100 MHz output and a frequency synthesizer used to correct the linear frequency drift of the maser. Note instability of phase-data at 100 S/s is  $\ll 1$  ps.

## 4 Outlook

The noise floor of the instrument is limited by common-mode phase flicker noise of the instrument. Future plans to improve the instrument are to 1) use an auxiliary phase calibration signal, as described in [6], and 2) to measure closure-error of three phase-meters in a triangular configuration as suggested in [3].

## References

- [1] G. Brida, "High resolution frequency stability measurement system", *Rev. Sci. Instrum.*, Vol. 73, pp. 2171-2174, 2002. (DOI: [10.1063/1.1464654](https://doi.org/10.1063/1.1464654))
- [2] J. Grove; J. Hein, J. Retta,; P. Schweiger, W. Solbrig, and S. R. Stein, "Direct-digital phase-noise measurement", in *Proceedings of the 2004 IEEE International Frequency Control Symposium and Exposition*, p. 287-291, 2004. (DOI: [10.1109/FREQ.2004.1418466](https://doi.org/10.1109/FREQ.2004.1418466))

- [3] J. A. Sherman and R. Jördens, "Oscillator metrology with software defined radio", *Rev. Sci. Instrum.* 87, paper 054711 (11 pages), 2016. (DOI: [10.1063/1.4950898](https://doi.org/10.1063/1.4950898))
- [4] C. Andrich, A. Ihlow; J. Bauer, N. Beuster, and G. D. Galdo, "High-Precision Measurement of Sine and Pulse Reference Signals Using Software-Defined Radio", *IEEE Trans. Instrum. Meas.*, Vol. 67, pp. 1132-1141, 2018. (DOI: [10.1109/TIM.2018.2794940](https://doi.org/10.1109/TIM.2018.2794940))
- [5] A. Wallin, T. Lindvall, T., K. Hanhijärvi (2018). "[Hajautetut vikasietoiset kelloverkot](#)", Maanpuolustuksen tieteellinen neuvottelukunta. Raporttisarja B.
- [6] S. Jablonski, K. Czuba, F. Ludwig, and H. Schlarb, "2 $\pi$  Low Drift Phase Detector for High-Precision Measurements", *IEEE Trans. Nucl. Sci.*, Vol. 62, No. 3, pp. 1142-1184, 2015. (DOI: [10.1109/TNS.2015.2425733](https://doi.org/10.1109/TNS.2015.2425733))