

## VTT Technical Research Centre of Finland

### TRIPOD

Pérez Sobrino, Mariano; Sánchez-Caja, Antonio; Quereda, Ramón; Masip, Jaime; Nijland, Maarten; Veikonheimo, Tomi; Kokkila, Kimmo; González-Adalid, Juan; Uriarte, Aitor

*Published in:*  
Ingeniería naval

Published: 01/01/2013

*Document Version*  
Peer reviewed version

[Link to publication](#)

*Please cite the original version:*

Pérez Sobrino, M., Sánchez-Caja, A., Quereda, R., Masip, J., Nijland, M., Veikonheimo, T., Kokkila, K., González-Adalid, J., & Uriarte, A. (2013). TRIPOD: The development of a novel propulsion concept. *Ingeniería naval*, LXXXII(919), 80-95. <https://dialnet.unirioja.es/servlet/revista?codigo=5151>



VTT  
<http://www.vtt.fi>  
P.O. box 1000FI-02044 VTT  
Finland

By using VTT's Research Information Portal you are bound by the following Terms & Conditions.

I have read and I understand the following statement:

This document is protected by copyright and other intellectual property rights, and duplication or sale of all or part of any of this document is not permitted, except duplication for research use or educational purposes in electronic or print form. You must obtain permission for any other use. Electronic or print copies may not be offered for sale.

## TÍTULO

TRIPOD: The development of a Novel Propulsion Concept.

## RESUMEN

El trabajo presentado en este informe ha sido desarrollado dentro del proyecto "TRIPLE Energy Saving by Use of CRP, CLT and PODded Propulsion (TRIPOD)", subvencionado por la Unión Europea a través del 7º Programa Marco (Grant# 265809). Este informe es de naturaleza pública y contiene todos los resultados del proyecto que se pueden difundir a la comunidad técnica mostrando los hallazgos de más relevancia y los resultados que pueden ser de interés general durante el desarrollo de un nuevo concepto propulsivo, formado por la combinación de tres tecnologías: hélice en POD, Configuración Contra-Rotativa y hélices tipo CLT®.

Se describen el contenido técnico y las fases del proyecto. Se presentan los desarrollos relevantes en Hidrodinámica del sistema CRP-POD, en aplicaciones de CFD a propulsores trabajando en configuración CRP y en los ahorros de energía que se han conseguido. Por último, aunque no lo menos importante, se ha realizado un análisis económico como parte de la validación del nuevo concepto propulsivo desarrollado en el proyecto.

## AUTORES

Pérez Sobrino, Mariano, Technical coordinator  
Sánchez-Caja, Antonio – VTT, Project coordinator.  
Quereda, Ramón - CEHIPAR.  
Masip, Jaime - CEHIPAR.  
Nijland, Maarten - A.P. MOLLER-MAERSK A/S.  
Veikonheimo, Tomi - ABB.  
Kokkila, Kimmo - ABB.  
González-Adalid, Juan - SISTEMAR.  
Uriarte, Aitor - CINTRANAVAL-DEFECAR.

## ABSTRACT

The work presented in this report has been developed inside the EU funding project "TRIPLE Energy Saving by Use of CRP, CLT and PODded Propulsion (TRIPOD)" (FP7-Grant# 265809). This report is of public nature and contains all the project results that can be released to the technical community showing the most relevant findings and developments that can be of general interest in the development of a novel propulsion concept formed by the combination of three technologies: podded propulsors, CRP configuration and endplate CLT propellers.

The technical content and the design phases of the project are described. Relevant developments in Hydrodynamics of CRP-POD system, in CFD applications to propellers working in CRP configurations and in the energy savings achieved are presented. Last but not least an economical analysis has been performed as part of the validation of the new propulsion concept developed in the project.

## Table of Contents

- 1.- Introduction.
- 2.- Technical description of the development of CRP-POD-CONV/CLT system.
  - 2.1.- Technical Work Packages.
  - 2.2.- Phases of Design Activities.
  - 2.3.- Programs of tests carried out.
  - 2.4.- Numerical calculations performed.
- 3.- Relevant developments
  - 3.1.- Hydrodynamics
    - 3.1.1.- New testing and extrapolation method for CRP propulsion systems.
    - 3.1.2.- CFD Numerical estimation of the effective wake.
    - 3.1.3.- Development of the RUDDER-POD.
    - 3.1.4.- Design of the propellers for Contra-Rotating configurations.
  - 3.2.- Energy Savings
  - 3.3.- Noise reduction
    - 3.3.1.- Brief Description of Cavitation Related Phenomena.
    - 3.3.2.- Reduction of Noise Actions.
    - 3.3.3.- Summary of Pressure Pulses Measurements.
    - 3.3.4.- Conclusions on Noise Reduction.
- 4.- Concept validation.
  - 4.1.- Trends in Propulsive Coefficients.
  - 4.2.- Economical Analysis.

## REFERENCES

## 1.- Introduction.

During the last two decades integral electric-driven “pod propulsor” units have been applied in increasing number to different types of vessels. As stated by the ITTC Specialist Committee on Azimuthing Podded Propulsion (2008), “looking back on the past years, podded propulsors have been treated as the new concept of marine outboard propulsive device, which has opened a new page on the history of marine propulsor.” Conscious of the relevance of the matter, the EU has supported projects related to electric driven units, being “pod propulsion” considered as one of the most promising home grown technologies. Among others, projects like OPTIPOD, POD-in-Service, and FASTPOD were funded and completed during the past years within EU framework programmes, and their achievements have prepared the way to the next phase of R&D in podded propulsion. These projects have addressed issues dealing with noise reduction, efficiency increase, manoeuvrability improvement, and mechanical robustness among others. Some Far East countries have also been interested in the podded propulsion market. A fast Japanese ROPAX Ferry has been equipped for the first time with an ABB hybrid CRP-POD system and energy savings of 13 percent have been claimed by the Japanese, contributing to a reduction both of operating costs and of CO<sub>2</sub> emissions.

In parallel the decade of the eighties witnessed a growing interest in unconventional propellers of tip loaded type. Blade tip loading (not allowed for conventional propellers without efficiency loss and high levels of noise) was made possible by placing an endplate at the blade outermost radial edge. After the first work of Gonzalo Perez on TVF propellers in the second half of the seventies, endplate propellers have evolved into CLT propellers during the eighties. Simultaneously other concepts of tip loaded propellers have appeared mainly in Europe and Japan promoted by several research groups. In the EU project Kapriccio a systematic study of Kappel propellers was made and three versions were manufactured, Andersen et al. (2002, 2005). In the EU funded LEADING EDGE project, scale effects on CLT propellers were numerically studied in fully turbulent flow using RANS solvers (Sánchez-Caja et al., 2006). The main interest has been in seeking more efficient ways of saving energy and additionally of developing environmentally-friendly propulsion systems by reducing propeller-radiated noise levels. As an example the super ferry FORTUNY has been equipped with CLT propeller and a reduction of noise and improved efficiency has been reported (Perez Gomez et al., 2006).

In Finland the ENVIROPAX project, investigated the Hybrid CRP-Podded propulsor concept including various hydrodynamic issues like power split, propeller design, powering performance evaluation (Varis, 2005). One of the major outcomes of this programme was the realization of the first two Hybrid CRP-Podded propulsor driven Ropax ferries built in 2004.

In Japan, a domestic coast tanker of 4999 GT, named “Shige Maru” was launched within the EcoShip project at Niigata Shipbuilding & Repair Corp. (NSR) in October 2007 (RINA, 2005). She has two sets of podded drive with contra-rotating propeller each of which absorbs 1250 kW. The Super EcoShip project was led by Ministry of Land, Infrastructure and Transport and National Maritime Research Institute from 2001.

From the examples of the previous paragraphs it can be deduced that large energy savings and consequently, CO<sub>2</sub> emission reductions are expected by a rational combination of the proposed technologies.

An additional advantage of using pod propulsion for gas emission reduction can be explained as follows. Diesel engines are the main source of power in the vast majority of the world’s ships. From an environmental point of view, however, these engines are not the friendliest. Fortunately pollution levels are not equal across the working range of the engine. In the optimum operating range, fuel efficiency is considerably higher and pollution lower than at low speeds. Therefore, the solution is to keep engines operating in this optimum range in all situations. With traditional mechanical transmission this is not possible, as engine speed is rigidly coupled to propeller speed. Using electric transmission (generators and motors connected by cables), this is no longer the case. Additionally, power reserves can be shared with the vessel’s on-board service supply, decreasing the total power installed while raising reliability.

Furthermore, cables are more flexible than shafts and permit greater freedom in the location of the engines. This can increase the vessel's payload or permit more efficient loading and unloading. All these advantages translate into greater productivity and savings for the owner.

In 2010 the Grant Agreement No 265809 was signed between the EU and the TRIPOD Consortium inside the Seventh Framework Programme to develop the R&D project titled "TRIPLE Energy Saving by Use of CRP, CLT and PODded Propulsion (TRIPOD)".

The main aim of TRIPOD is to combine these technologies (podded propulsors, CRP configuration and endplate CLT propellers) and explore the feasibility and potential benefits to be gained by the use of such an innovative propulsion system.

The consortium includes firms and research institutes that are complementary in the technological areas of investigation required in the project. ABB is a world leader expert in the design of podded propulsors. They introduced the concept of podded propulsion for the first time about two decades ago, which has been considered an important milestone in the history of marine propulsion. SISTEMAR is the world leader in number of tip loaded propeller designs installed on actual ships. They pioneered the research on tip loaded propellers and were the first to reach practical applications in the form of CLT propellers. VTT has been at the forefront of the hydrodynamic research in pods from the point of view of both model tests and CFD, and in CFD applied to endplate propellers. CEHIPAR has the largest experience and data base on model tests on CLT propellers, and they have strong expertise in noise evaluation. CND is engineering office with broad knowhow in ship design. Their contribution is needed for reaching practical solutions in the project from the engineering/technical standpoint. MAERSK is a worldwide leading operator of cargo ships. Their contribution is needed for reaching practical solutions in the project from the economical/exploitation standpoint.

## **2.- Technical description of the development of CRP-POD-CONV/CLT system.**

The TRIPOD project is oriented to the development of a hybrid technology by integrating three propulsion concepts, two of them recently emerged: electric podded drives, endplate CLT propellers in CRP configuration. In this way the benefits of podded propulsion technology (i.e., higher propulsion efficiency, better maneuverability, improved wake to the propeller, noise reduction, simpler engine control, more flexibility for the selection of ship forms in the hydrodynamic design of the stern) can be combined with those of endplate propellers (i.e., better propeller efficiency, vibration reduction, smaller optimum diameter and consequently smaller pod units for a given delivered power) and with those of CRP units (better efficiency by blade unloading and by rotational energy loss recovery). This will contribute to a more rational and realistic way of saving energy.

Endplate propellers are known to offer several advantages for particular marine applications where limitations of propeller diameter and/or strong hull wakes at the propeller location are present. From the standpoint of propeller vibrations, the longer chord lengths at the propeller tip and smaller optimum diameter allow the propeller sections to work in wider sectors of the propeller disk covering simultaneously areas where the changes in local wake can be strong. Additionally, for many pod applications characterized by a almost uniform inflow the availability of longer chords at the tip may locally decrease the loading per square meter at the region more prone to cavitate (the tip) and consequently in some cases cavitation extension may be reduced.

TRIPOD will include studies of scale effects on CLT podded units as well as statements on cavitation performance, which are the main issues of interest for a successful completion of the project. State of the art numerical CFD tools will be used in order to reduce the number of iteration loops in model tests. Conversely model test measurements will be used to validate CFD tools. Grid adaptation methods will be employed for a fast modification of the computational meshes.

TRIPOD aims at gaining and consolidating European leadership in key scientific and technological areas like ship propulsion through the establishment of a collaborative research project on efficient ship transportation. This is one of the priorities stated in the FP7 Cooperation Work Programme.

## 2.1.- TECHNICAL WORK PACKAGES

The project is organized into five interrelated technical WPs (WP1 to WP5), one devoted to dissemination (WP6) and one devoted to the management of the project (WP7). Each WP has a number of tasks assigned. There is a partner in charge of each task. Most of the tasks are performed by a single partner even though some of them require the collaboration of several partners.

- WP1 - CONCEPT EXPLORATION
- WP2 - HYDRODYNAMIC DESIGN
- WP3 - NUMERICAL ANALYSIS
- WP4 - MODEL TESTS
- WP5 - CONCEPT VALIDATION
- WP6 - DISSEMINATION
- WP7 - MANAGEMENT

The schematic representation of the technical WPs as well as the transferring of information between them is illustrated in Figure 2.1.1.

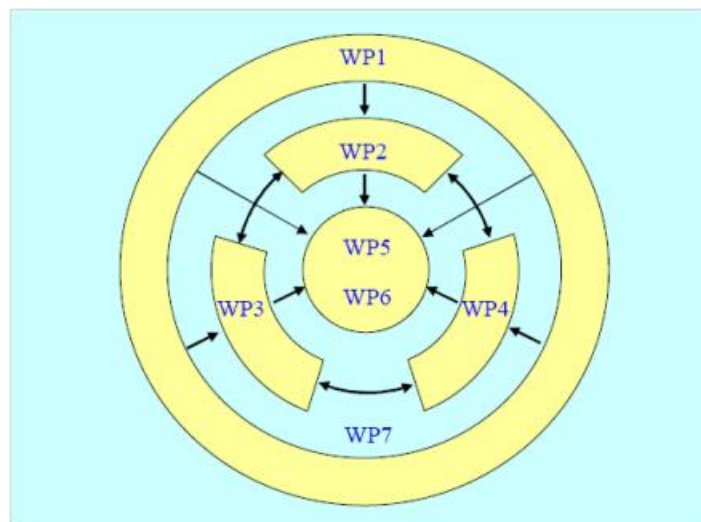

**Figure 2.1.1.- Schematic relationship between Work Packages in TRIPOD project.**

There is a strong interrelation between WP2, WP3 and WP4 since WP2 dealing with the design produces outputs to the numerical and experimental WPs (WP3 and WP4) and also receives inputs from WP3-WP4 during the design iterations.

In particular the information gathered in WP1 will be used in WP2 in order to make the designs of both the pod housing for the CRP and the optimized hull geometry. At the same time the information in WP1 on hull forms will be transferred to WP4 in order to make model test (including resistance and self-propulsion tests). The information on effective wake from WP4 will be used in turn in WP2 as input to the CLT propeller designs. The CLT propeller geometries coming from WP2 will be tested in WP4.

All WPs provide WP5 with the necessary information for the overall assessment and final recommendations on the new propulsion concept, as well as for the dissemination activities.

First decision in WP1 was the selection of the reference vessel to be used in the project. AP Moller-MAERSK identified a reference vessel with waste heat recovery and more spare electrical power: Gudrun Maersk.



*Figure 2.1.2.- GUDRUN MAERSK – Reference vessel for TRIPOD Project*

The main particulars of the hull form of this ship are:

		Scale factor:	38,913	
<b>Hull#:</b>	<b>2380</b>	<b>Ship</b>		<b>Model</b>
LPP	LENGTH BETWEEN PERPENDICULARS	351,081	m	9,0222
B	MOULDED BEAM	42,800	m	1,0999
TM	MEAN DRAUGHT (AT SECTION 10)	12,200	m	0,3135
TPP-TPR	TRIM	0,000	m	0,0000
VSAP	VOLUME WITHOUT APPENDAGES	117437,5	m**3	1,9931

The scale factor selected for all models developed has been 38,913, giving result to a hull model of more than 9 m length.

The engine output is 68640 kW MCR at 102 rpm and the original propeller has 8.950 m in diameter and 6 blades.

Such an impressive ship has been very well optimized inside MAERSK technical departments, representing a real challenge to improve her performance by a novel concept never tested before.

## 2.2.- PHASES OF DESIGN ACTIVITIES.

The ultimate goal of work-package WP2 of TRIPOD project is to produce new designs of conventional and CLT propellers to be used in a CRP-POD configuration as an alternative to the existing main propeller

configuration. The design activities have been performed in two phases called “retrofit scenario” and “new building scenario” respectively.

Retrofit Scenario. In simple retrofit scenario the reference ship hull form has been kept as it was. A first design of an equivalent CLT propeller has been developed (CLT1); afterwards the original horn rudder has been removed and Rudder-Pod designed and installed. The main conventional (CONV1) propeller is the same as in original vessel and its location related to hull remained the same; two new designs have been developed to work in Contra-Rotating Configuration (CRP) as POD propellers: one of conventional type (CONV3) and other of CLT type (CLT3).

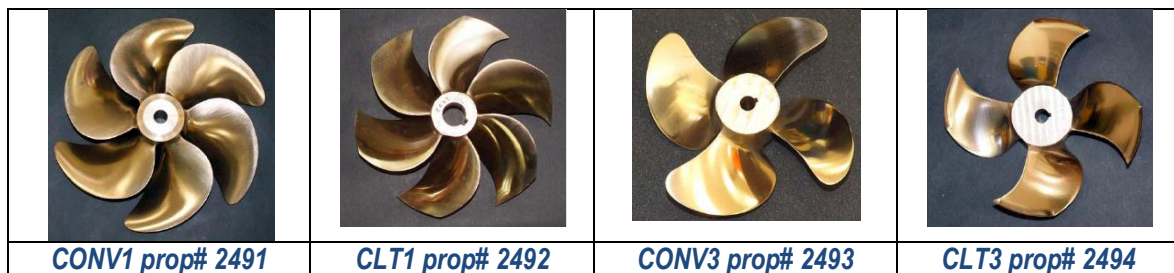

**Figure 2.2.1.- Model propellers developed in “Retrofitting Scenario”**

Ship performance calculations including numerical CFD calculations for Rudder-POD have been carried out and detailed propeller designs for the following propulsion configurations:

- ✓ Existing conventional propeller (CONV1)
- ✓ Alternative CLT propeller (CLT1)
- ✓ CRP-POD configuration with the existing conventional propeller as main propeller and a conventional Rudder-Pod propeller (CONV1+POD/CONV3).
- ✓ CRP-POD configuration with the existing conventional propeller as main propeller and a CLT Rudder-Pod propeller (CONV1+POD/CLT3).

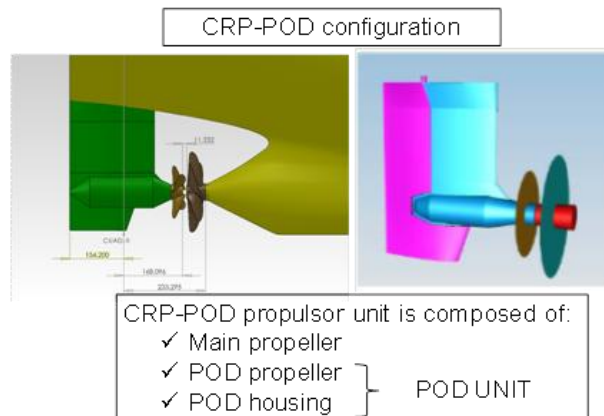

New Building Scenario. This is the case of a new optimized hull design for CRP and developing new propellers designs and testing in full load and ballast conditions in order to be able to evaluate the possible advantages of this system. Both types of propellers will be designed: conventional and CLT type propellers.

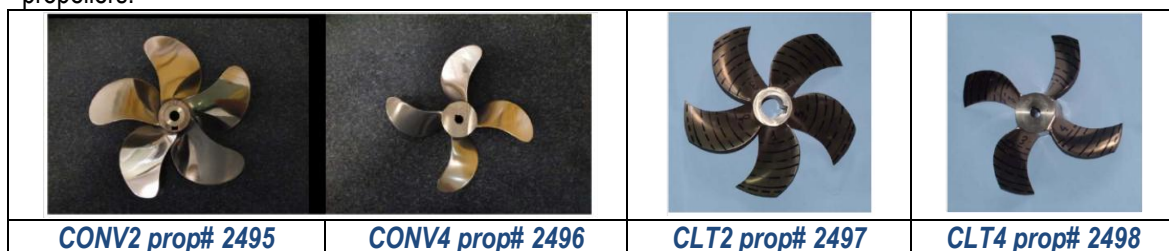

**Figure 2.2.2.- Model propellers developed in “New Building Scenario”**

Ship performance calculations including numerical CFD calculations to optimize new hull have been carried out and detailed propeller designs for the following propulsion configurations:



- ✓ CRP-POD configuration with optimum conventional propellers as main and Rudder-Pod propellers (CONV2+POD/CONV4).
- ✓ CRP-POD configuration with optimum CLT propellers as main Rudder-Pod propellers (CLT2+POD/CLT4).

### 2.3.- PROGRAMS OF TESTS CARRIED OUT.

The main aim of TRIPOD is to combine three technologies (poded propulsors, CRP configuration and endplate CLT propellers) and explore the feasibility and potential benefits to be gained by the use of such an innovative propulsion system.

The way the project has been set up allows considering both energy optimization of existing ships and of new designs at full load and ballast condition. The optimization of existing ships is tackled in the first part of the project where a retrofitting of the propulsion unit is considered. In the second part a new building scenario is considered.

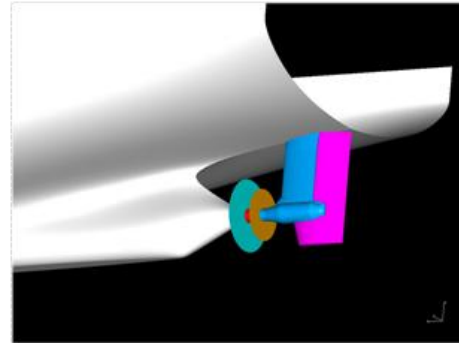

The main objectives of the model tests programs are:

- 1) Performing complete propulsion tests of the ship models for the cases of retrofitting and new hull design. The tests will allow evaluating the new propulsion concept from the point of view of energy saving.
- 2) Performing cavitation and pressure fluctuation tests to assess the impact of the new propulsion concept on the induced vibrations transmitted to the hull.
- 3) Finding the ship hull flow to the propeller both for the original hull and for the optimized one from the CRP-POD-CLT propulsion standpoint.
- 4) Additionally the test measurements will be used to validate CFD computations.



Five programs of tests have been scheduled. Each program of tests includes:

- ⇒ Construction of required models: hull, propellers, pod housing.
- ⇒ Resistance tests with and without pod housing.
- ⇒ Open Water tests (propellers alone, pod+conventional propeller open water test, POD+CLT open water test, CRP open water test [main propeller+pod propeller]).
- ⇒ Propulsion tests
- ⇒ Cavitation observation tests including pressure fluctuation measurements

In order to make more feasible the retrofit scenario from the standpoint of the ship owner, i.e. reducing costs, the scenario will keep the original main propeller as it is, and will add a POD propeller working at a rate of revolutions proportional to the revolutions of the main propeller, thanks to a simple electrical driving system consisting of a generator coupled to the main engine that provide the main electrical energy to the pod propeller. This retrofit scenario includes all the studies carried out with the original hull form:

- Tests with original propeller (CONV1)
- Tests with a CLT propeller (CLT1) replacing the original CONV1
- Tests with a Rudder-Pod unit replacing the original rudder, forming a CRP system, maintaining always the original CONV1 propeller, but testing two cases in the POD propeller:
  - ✓ CRP configuration: Main propeller CONV1+ POD propeller CONV3
  - ✓ CRP configuration: Main propeller CONV1+ POD propeller CLT3

The new ship scenario assumes that the after body of the ship would be slightly modified to install the new CRP-POD system maintaining all the main particulars of the ship. To reinforce the ship owner confidence in the results, tests in ballast condition have been added in the case of new building scenario. To obtain better comparison data two cases have been studied: with optimum conventional propellers and with CLT propellers. The following studies have been performed with the new hull:

- CRP configuration: Main propeller CONV2 +POD propeller CONV4
- CRP configuration: Main propeller CLT2 + POD propeller CLT4

Scenarios in TRIPOD Project				
	Task	Main propeller	POD propeller	Ship condition
RETROFIT scenario	T4.1	CONV1	-	full load
	T4.2	CLT1	-	full load
	T4.3	CONV1	CONV3	full load
		CONV1	CLT3	full load
New Design scenario	T4.4	CONV2	CONV4	full load
		CONV2	CONV4	ballast
	T4.5	CLT2	CLT4	full load
		CLT2	CLT4	ballast

Therefore retrofit scenario includes all the tests carried out inside tasks T4.1, T4.2 and T4.3. Table 3.1 can help to clarify the tests carried out in this scenario with respect to the performance of the ship (resistance, open water and self-propulsion tests).

The summary of the performance tests carried out in the new-building scenario inside T4.4 and T4.5 are reflected in table 3.2.

In all these tasks cavitation observation tests including measurement of pressure pulses have been performed. All the tests have been recorded in high speed video allowing detailed observation of the cavitation related phenomena.

Task	Test#	Hull#	Propeller#	Test type
T4.1	18932	2830		Resistance w/app. (Rapp)
	18927		2491-CONV1	Open Water (OW)
	18934	2830	2491-CONV1	Self-propulsion (P)
T4.2	18930		2492-CLT1	OW
	18933	2830	2492-CLT1	P
T4.3	19002	2830		R without Rudder
	18949		2493-CONV3	OW
	19020		2493-POD/CONV3	OW with POD
	19026		CRP CONV1+POD/CONV3	OW CRP system
	18979		2494-CLT3	OW
	19017		2494-POD/CLT3	OW with POD
	19027		CRP CONV1+POD/CLT3	OW CRP system
	19048	2830	CRP CONV1+POD/CONV3	P
	19049	2830	CRP CONV1+POD/CLT3	P

**Table 2.3.1.- Performance tests in retrofit scenario**

Task	Test#	Hull#	Propeller#	Test type
T4.4	19097	2830A		R w/o app, Tm=7,950m
	19098	2830A		R w/o app, Tm=12,200m
	19091		2495-CONV2	OW
	19092		2496-CONV4	OW
			2496-POD/CONV4	OW with POD
	19108		CRP CONV2+POD/CONV4	OW CRP system
	19120	2830A	CRP CONV2+POD/CONV4	P, Tm=12,200m
	19123	2830A	CRP CONV2+POD/CONV4	P, Tm=7,950m
T4.5	19095		2497-CLT2	OW
	19094		2498-CLT4	OW
	19107		2498-POD/CLT4	OW with POD
	19109		CRP CLT2+POD/CLT4	OW CRP system
	19122	2830A	CRP CLT2+POD/CLT4	P, Tm=12,200m
	19124	2830A	CRP CLT2+POD/CLT5	P, Tm=7,950m

**Table 2.3.2.- Resistance (R), Open water (OW) and self propulsion (P) tests carried out in tasks of new building scenario.**

#### 2.4.- NUMERICAL CALCULATIONS PERFORMED.

CFD computations were made in WP3 to facilitate the design tasks in WP2. They allow knowing how pressure and friction forces are affected by certain types of geometric modifications studied within the TRIPOD concept, and consequently what is the impact on propeller efficiency and cavitation behavior caused by such modifications. Most of the CFD computations have been made in full scale since this is the main concern of the project. In particular computations were conducted for endplate shape optimization, and for the analysis of the propellers in different scenarios subject to study. Grids were built up to 12 million cells for this purpose.

The validation exercises of numerical results were made for some computations for which model tests results were available. Most of the computations, for example those concerning pod housing and endplate propeller shape optimization were not tested in model experiments. This was one of the purposes of using CFD tools: reducing the number of model tests.

Some relevant results of CFD computations are shown in next paragraph.

### 3.- Relevant developments.

#### 3.1.- HYDRODYNAMICS

A large effort has been dedicated to experiments, analysis and computations in the hydrodynamics field. Here below some relevant developments are presented.

##### 3.1.1.- New testing and extrapolation method for CRP propulsion systems.

A new procedure for the extrapolation of the results obtained with model tests of this new system consisting of a main propeller and a POD propeller in a CRP configuration was introduced. The method includes the procedure to perform model tests and is based in the ITTC-78 procedure and in its related ITTC procedures and recommendations.

Specific devices have been designed and manufactured to carry out the tests in the CEHIPAR calm water towing tank. Two independent dynamometers must be used to obtain all the needed measurements both in the Open Water and in the Self-Propulsion tests. The POD dynamometer has the possibility of measure the thrust of the propeller and the total force of the POD UNIT transmitted to the hull.

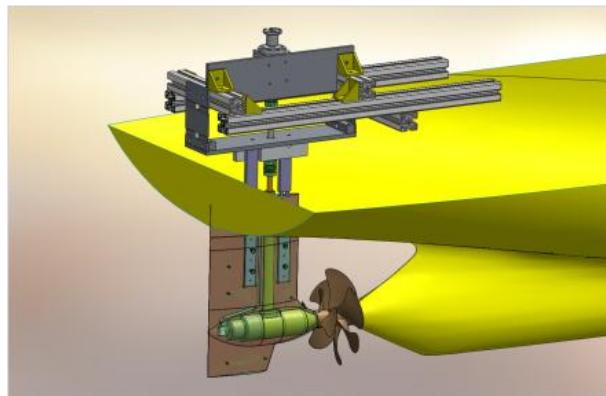

*Fig. 3.1.1.1.- Arrangement for self propulsion tests.*

As this method has been explained in detail in ref (1), here below only the main assumptions and relevant findings will be exposed. The procedure for the extrapolation of model tests results is based in the following considerations:

- ⇒ The propulsor is considered as a unit composed of the main propeller and the POD propeller arranged in Contra-Rotating configuration. That means that the POD drive support is considered part of the propulsor and therefore it is not included in the resistance test.
- ⇒ The scaling of the Open Water tests of the propellers are carried out according to the standard ITTC-78 method in case of conventional propellers and with some additional specific corrections in case of end plate CLT propellers as explained in reference [3].
- ⇒ Open Water tests of the POD unit must be performed with the POD drive support, obtaining measurements of the pod propeller thrust,  $T_{m2}^*$ , and the total thrust of the POD UNIT,  $T_{mUNIT}^*$ , that is the thrust produced by the POD propeller minus the drag of the POD housing,  $R_{mPH}^*$ .

$$T_{mUNIT}^* = T_{m2}^* - R_{mPH}^*$$

⇒ Hence the extrapolation of the POD UNIT Open Water tests includes a correction for the frictional scale effects of the drag of the POD housing R\*mPH. Using the sub index 1 to refer to the main propeller and sub index 2 to refer to the POD propeller, in summary the extrapolation of the OW tests of the CRP-POD system corresponds to the following formulation:

Main propeller THRUST:

$$T_{S1} = (K_{Tm1} + \Delta K_{T1}) \rho_S n_{S1}^2 D_{S1}^4$$

Where  $\Delta K_{T1}$  is calculated according to ITTC'78 correction for main propellers.

POD unit THRUST:

$$T_{SUNIT} = (K_{TmUNIT} + \Delta K_{T2} + \Delta K_{TPH}) \rho_S n_{S2}^2 D_{S2}^4$$

Where  $\Delta K_{T2}$  is calculated according with ITTC'78 correction for conventional propellers, and

$$\Delta K_{TPH} = \frac{R_{mPH}}{\rho_m n_{m2}^2 D_{m2}^4} \left(1 - \frac{C_{FS}}{C_{Fm}}\right)$$

THRUST coefficient of the CRP-POD system is:

$$K_{TS} = \frac{T_{S1} + T_{SUNIT}}{\rho_m n_{m1}^2 D_{m1}^4}$$

Main propeller TORQUE:

$$Q_{S1} = (K_{Qm1} + \Delta K_{Q1}) \rho_S n_{S1}^2 D_{S1}^5$$

POD unit TORQUE:

$$Q_{S2} = (K_{Qm2} + \Delta K_{Q2}) \rho_S n_{S2}^2 D_{S2}^5$$

Where  $\Delta K_{Q1}$  and  $\Delta K_{Q2}$  are the corresponding corrections of Main and POD propellers calculated for each one depending whether they are conventional or end plate CLT. There is no new specific correction in Torque for the POD unit.

TORQUE coefficient of the CRP-POD system is:

$$K_{QS} = \frac{Q_{S1} n_{S1} + Q_{S2} n_{S2}}{\rho_m n_{m1}^3 D_{m1}^5}$$

Finally the open water curves of the propulsion system for the ship include parameters  $K_{TS}$  and  $K_{QS}$  represented in terms of the advance coefficient  $J_S$ :

$$J_S = \frac{V_S}{n_{S1} D_{S1}}$$

- ⇒ In self-propulsion tests load variations are produced by varying the main propeller rpm,  $n_{m1}$ , and POD propeller rpm,  $n_{m2}$ . In this case the electrical drive of the POD propeller produces a fixed relation rate between  $n_{m1}$  and  $n_{m2}$ :

$$RR = \text{RPM POD propeller} / \text{RPM Main propeller}$$

Two independent dynamometers allow to measuring the rpm and torque on each propeller,  $Q_{m1}$  and  $Q_{m2}$ , at each model velocity. A minimum of three values of  $n_{m1}$  are used for each hull model speed to establish the load variation of the propellers. The self propulsion point is determined interpolating in the measured data of the load variation test. The frictional deductions due to hull model,  $F_{DHULL}$ , and pod housing,  $F_{DPH}$ , must be considered to calculate the total frictional deduction.

$$F_{Dm} = F_{DHULL} + F_{DPH}$$

$$F_{DHULL} = \frac{\rho_m S_m V_m^2}{2} [(1+k)(C_{Fm} - C_{Fs}) - \Delta C_F]$$

Where  $S_m$  is the hull model wetted surface. The deduction fraction on pod housing,  $F_{DPH}$ , is calculated.

$$F_{DPH} = R_{mPH} \left(1 - \frac{C_{Fs}}{C_{Fm}}\right)$$

- ⇒ The thrust deduction fraction  $t$  is considered same value for model and full scale ship,  $t(\text{model}) = t(\text{ship})$ :

$$1 - t = \frac{R_m - (F_{DHULL} + F_{DPH})}{T_{m1} + T_{mUNIT}}$$

- ⇒ The effective wake fraction for the ship,  $w_{TS}$ , based on thrust identity is extrapolated according with:

$$w_{TS} = t + (w_{Tm} - t) \frac{(1+k_S)C_{FS} + \Delta C_F}{(1+k_m)C_{Fm}}$$

- ⇒ Once determined the  $J_{Tm}$  value, the non dimensional parameter  $K^{ow}_{Qm}$  is read off from the Open Water test curves of the propulsion system, and with  $K_{Qm}$  from self propulsion test, the rotative-relative coefficient could be determined:

$$\eta_R = \eta_{Rm} = \frac{K^{ow}_{Qm}}{K_{Qm}} = \eta_{RS}$$

as in the ITTC'78 method it is considered that no scale effect exists in the rotative-relative coefficient.

- ⇒ The load of the full scale propeller is obtained:

$$\frac{K_{TS}}{J_{TS}^2} = \frac{S_S}{2D_1^2} \frac{C_{TS}}{(1-t)(1-w_{TS})^2}$$

⇒ With this  $K_{TS}/J_{TS}^2$  as input value the full scale advance coefficient  $J_{TS}$ , thrust coefficient  $K_{TS}$  and the torque coefficient  $K_{QTS}$  are read off from the full scale propeller characteristics and the following quantities are calculated:

$$n_{S1} = \frac{(1 - w_{TS})V_S}{J_{TS}D_{S1}} \quad (\text{rps})$$

Thrust,  $T_S$ :

$$T_S = \frac{K_{TS}}{J_{TS}^2} J_{TS}^2 \rho_S n_{S1}^2 D_{S1}^4 \cdot 10^{-3} \quad (\text{kN})$$

The delivered power:

$$P_{DS} = 2\pi\rho_S n_{S1}^3 D_{S1}^5 \frac{K_{QS}}{\eta_R} \cdot 10^{-3} \quad (\text{kW})$$

The total propulsive efficiency:

$$\eta_D = \frac{P_E}{P_{DS}} = \frac{R_{TS}V_S}{P_{DS}}$$

⇒ The share of power between both propellers is computed through the determination of the specific load and the OW curves of each propeller:

Load of full scale main propeller:

$$\frac{K_{TS1}}{J_{TS}^2} = \frac{S_S}{2D_1^2} \frac{C_{TS} \cdot \frac{T_{S1}}{(T_{S1} + T_{S-UNIT})}}{(1-t)(1-w_{TS})^2}$$

Predictions for Main propeller at full scale:

Rotation rate of Main propeller, rps

$$n_{S1} = \frac{(1 - w_{TS})V_S}{J_{TS}D_{S1}}$$

THRUST of Main propeller, N:

$$T_{S1} = \left( \frac{K_{TS1}}{J_{TS}^2} \right) J_{TS}^2 \rho_S n_{S1}^2 D_{S1}^4$$

Delivered Power in Main propeller, kW:

$$P_{DS1} = 2\pi\rho_S n_{S1}^3 D_{S1}^5 \frac{K_{QS1}}{\eta_R} 10^{-3}$$

Load of full scale POD UNIT:

$$\frac{K_{TS-UNIT}}{J_{TS}^2} = \frac{S_s}{2D_2^2} \frac{C_{TS} \cdot \frac{T_{S-UNIT}}{(T_{S1} + T_{S-UNIT})}}{(1-t)(1-w_{TS})^2}$$

Predictions for POD propeller at full scale:

Rotation rate of POD propeller, rps

$$n_{S2} = RR \cdot n_{S1}$$

THRUST of POD propeller, N:

$$T_{S-UNIT} = \left( \frac{K_{TS-UNIT}}{J_{TS}^2} \right) J_{TS2}^2 \rho_s n_{S2}^2 D_{S2}^4$$

Delivered Power in POD UNIT, kW:

$$P_{DS2} = 2\pi \rho_s n_{S2}^3 D_{S2}^5 \frac{K_{QS2}}{\eta_R} 10^{-3}$$

⇒ Cavitation tests have been carried out at CEHIPAR cavitation tunnel:

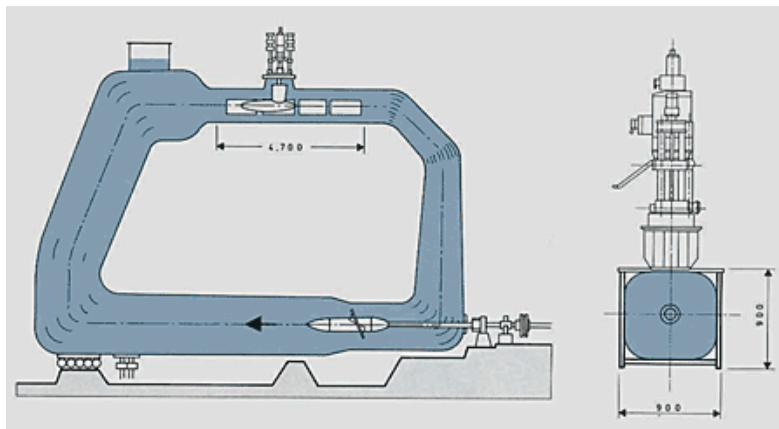

**Fig. 3.1.1.2. Cavitation tests facilities at CEHIPAR.**

A dummy model has been designed and manufactured to carry out the tests into the cavitation tunnel. Wake field on the forward propeller disc were reproduced with the aid of a mesh allocated at both sides of the model.

A dummy model has been designed and manufactured to carry out the tests into the cavitation tunnel. Wake field on the forward propeller disc were reproduced with the aid of a mesh allocated at both sides of the model.

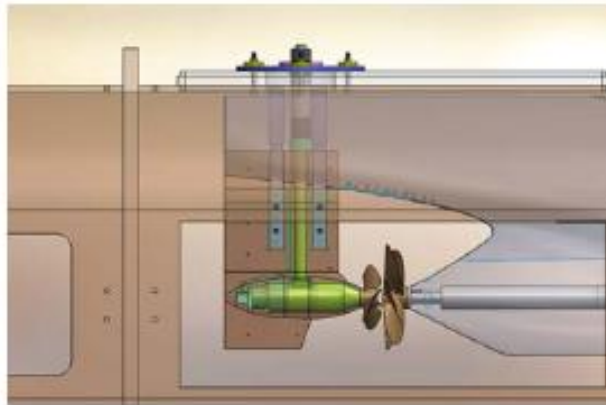



**Fig. 3.1.1.3.- Dummy model for cavitation tests with CRP-POD system.**

Holes to situate the pressure transducers on the stern of the dummy have been prepared.

A new Pod dynamometer was designed and manufactured to control the pod propeller parameters during cavitation observation test.



**Fig. 3.1.1.4.- Arrangement of cavitation tests with CRP-POD system.**

To carry out the cavitation observation test in the tunnel, the  $K_T$  value is calculated for the main propeller performance at the selected ship navigation condition:

$$K_T = \frac{T_{S1}}{\rho_S n_{S1}^2 D_{S1}^4} = \frac{T_{m1}}{\rho_m n_{m1}^2 D_{m1}^4}$$

Thrust,  $T_{S1}$ , and rpm on the main propeller,  $n_{S1}$ , are selected from ship navigation condition. To carry out the tests the rpm of the main propeller model,  $n_{m1}$ , is selected and the corresponding thrust on the main propeller is obtained to attain the  $K_T$  value. The model pod propeller rpm must be adjusted to maintain the rpm ratio on both propellers.

The cavitation index is calculated according with the main propeller characteristics.

$$\sigma = \frac{P_{0s} - P_{sv}}{\frac{1}{2} \rho_S n_{S1}^2 D_{S1}^4}$$

The pressure pulses are measured during the cavitation observation tests at the same testing conditions. To extrapolate the pressure pulse amplitudes similar criteria than for conventional propeller were used.

$$K_P = \frac{P_{KS}}{\rho_S n_S^2 D_S^2} = \frac{P_{Km}}{\rho_m n_m^2 D_m^2}$$

Pressure pulse amplitudes are extrapolated for Main propeller according to:

$$P_{KS1} = P_{Km1} \frac{\rho_S n_{S1}^2 D_{S1}^2}{\rho_m n_{m1}^2 D_{m1}^2}$$

And for POD propeller:

$$P_{KS2} = P_{Km2} \frac{\rho_S n_{S2}^2 D_{S2}^2}{\rho_m n_{m2}^2 D_{m2}^2}$$

### 3.1.2.- CFD Numerical estimation of the effective wake.

Concerning advancement of CFD methods, a correction factor approach has been developed for the estimation of effective wakes during the project. Here our main focus is the effective wake generated by the each propeller of the CRP unit on the other. The axial and tangential effective wakes have been estimated by combining a RANS solver for the solution of the bulk flow around a Rudderpod and a potential flow lifting-line method for simulating the forces generated by the propeller. The potential flow solution has been expressed in terms of actuator disk theory and two disks working in contra-rotating mode have been coupled to the RANS solver. The computations were made at full scale. The FINFLO code was used for the calculations. The grids contained about 5 million cells. The computational approach allows splitting the complex flow due to the interaction of the main propeller, pod propeller and pod housing in basic problems where an effective inflow is obtained for each propeller. The effective inflow obtained in this way can be used for propeller analysis and design.

The correction factor approach can be explained as follows. A potential-flow lifting-line (LL) method is interactively combined with a viscous RANS solver to predict the effective wake at the propeller location. Propeller forces obtained from the potential flow solver are expressed in terms of axi-symmetric body forces and introduced as input to the viscous solver. In turn, an effective wake field is derived from the RANS solver by subtracting the axi-symmetric component of the propeller induced velocities from the total velocities in the bulk flow. The effective wake thus obtained will be the input to the LL code for the next iteration. Usually, the velocities induced by the viscous solver are close but do not coincide with those estimated by the potential LL code. This introduces an error in the prediction of the effective wake, which in turn will result in design errors when estimating the propeller pitch. The differences will be more significant for large propeller loadings. The correction factor approach allows canceling this numerical error by defining correction factors that are independent of the advance number. These correction factors should work accurately in the neighborhood of the reference advance number and, therefore, need to be evaluated only once (for reference advance number). In practical applications the reference advance number can be chosen around that corresponding to the nominal wake fraction.

In a second stage the propellers can be analyzed subject to the calculated effective wakes. Here the full geometry of the propeller has been modeled and analyzed in using RANS and unsteady lifting surface vortex lattice analysis. In Figure 3.1.2.1 the computed total effective wakes are shown at the propeller disks for the new building scenario.

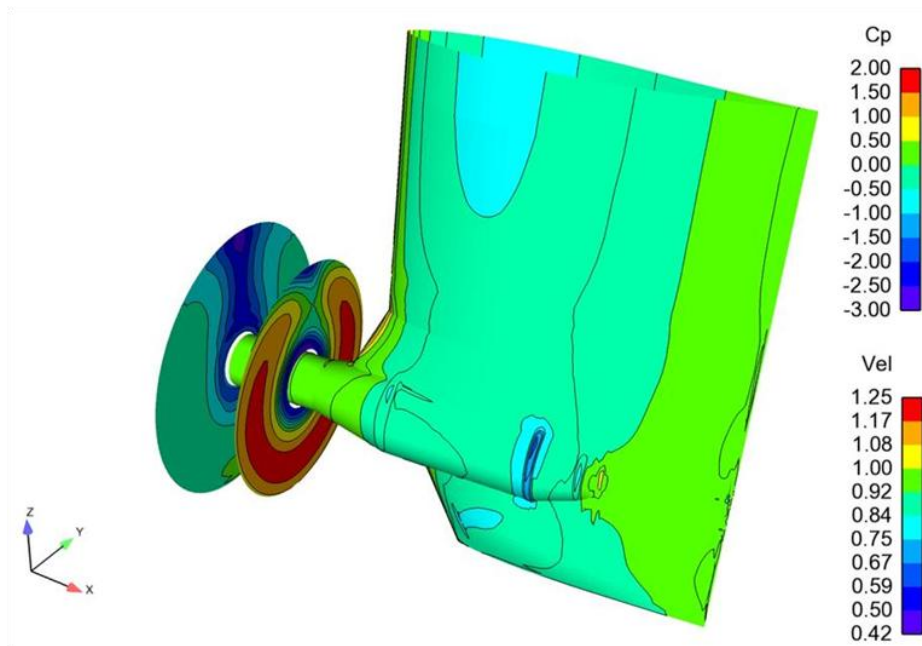
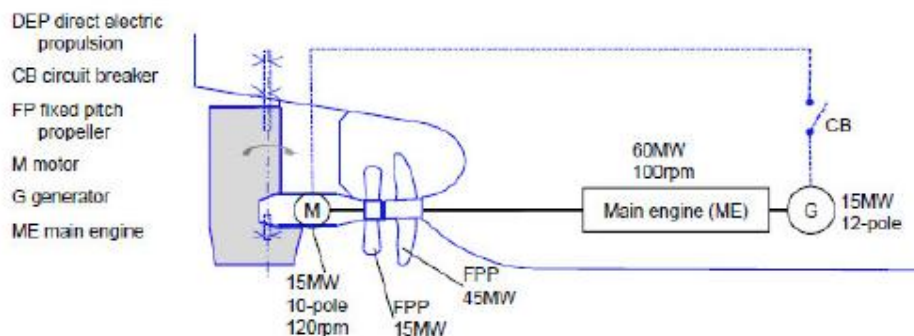

**Figure 3.1.2.1 Effective wake for the total velocities at the propeller disks. The colors represent pressures on the pod surfaces and velocities on the propeller disks. New building scenario.**

### 3.1.3.- Development of the RUDDER-POD.

The basic idea of the RudderPod concept is that it should be suitable for the cargo vessel segment where reliability and economical operation are of high importance. Typical and suitable vessels in this segment would be large container vessels, LNG vessels and car carriers. The propulsion concept should be as simple as possible to operate and maintain. It is believed that when the system is simple the amount of moving components and fixed parts should be as small as possible. Then the reliability increases, and the need of maintenance for the system is lowest.

ABB developed at the end of the nineties the CRP Azipod concept where the Azipod propulsion was combined with the ship main propeller. The pod propeller was a FPP propeller and the main one was either CPP or FPP. Then ABB got the idea of combining the widely used simple rudder and the efficient podded propulsion in a contrarotating propeller (CRP) system. This system includes the rudder as a simple known reliable steering device and a streamlined pod structure that houses the electric motor inside. The main propeller is driven by a 2-stroke diesel engine and the after propeller that is rotating to the opposite direction is separated and connected to electric motor in the pod unit. In the following picture this new system concept is shown.



**Figure 3.1.3.1.- Rudder-Pod system.**

## Design Iterations

Several design iterations were made to optimize the Rudder-Pod for this application. A first version of the pod housing for the CRP unit was made and analyzed by CFD. The strut was of short chord length. In the figure below (attached figure 3.1.3.2) is shown the pressure distribution on the surfaces of the preliminary pod unit. The viscous drag was small due to the reduced wetted area. This version was considered adequate for rotatable pod units where the wetted area can be reduced as much as possible due to the fact that on the one hand there is no noticeable rotational energy to be recovered by the strut in CRP units, and on the other hand from the standpoint of steering forces, rotatable units do not rely on the strut wetted area so much as on the propeller orientation and thrust force.

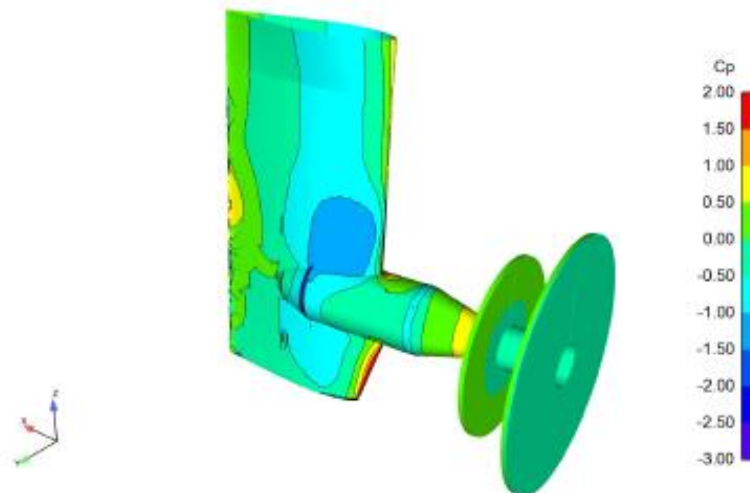

**Figure 3.1.3.2.- First option strut calculated with CFD**

However, rotatable units need more maintenance and are more expensive than fixed (stationary) units. Trying to reduce costs and to make the TRIPOD concept economically feasible, it was decided to use stationary units (Rudderpod concept). With this choice, it was unclear whether the strut geometry provides sufficient steering forces compared to conventional rudder. Therefore a design philosophy was followed in which the steering forces were to be kept the same as those of the original rudder. This was guaranteed by aiming at a wetted area in the strut moving part of about 80% than the original rudder. This choice was taken because of the skeg effect to be explained next.

It is known that flaps produce more lift when working (as it is usual) behind a fixed skeg, than when working as an independent rudder. Theoretically, for two-dimensional flow the increase of lift for the same deflection angle is 1.64 for a pivoting point located at midchord. The farther the pivoting point is located from the leading edge, the larger is the deflection angle factor. For three-dimensional flow the coefficient will be somewhat smaller. In our particular case the skeg effect is larger for the pod housing unit than for the original rudder, therefore the wetted area could be reduced without losses in the steering capabilities.

## Selection of Rudder area

The selection of the Rudderpod area was an especially important item. For the Gudrun Maersk the original rudder and its dimensions were known. The area of the existing rudder however was large and technically difficult to apply to the RudderPod case. It was decided to reduce the active RudderPod area by 20%, because it was believed that the effect of the larger passive strut part on course keeping reduces the need of active part area. Additionally, the presence of a passive area of relative large length on the top of the pod increases the lifting capabilities of the active area located just behind. Some potential flow calculations confirm that the reduction of active area should not be a problem.

	Active area [m <sup>2</sup> ]	Passive area [m <sup>2</sup> ]	Total area [m <sup>2</sup> ]
RudderPod	65	60	125
Conventional rudder	81	32	113

*Table 3.1.3.1. Comparison of active and passive areas*

### Conventional rudder shape vs. RudderPod

The steering axis of semi balanced rudders is usually located so that some 25... 30% of rudder area is in front of steering axis. This reduces the dimensions on steering gear. In the RudderPod this is difficult to achieve because the steering axis needs to be as close to the dividing split as possible. The lower support bearing has to be located just after the electric motor. Most of the balancing area could be located in the lower part of the RudderPod under the torpedo. In this way a technically feasible solution could be found.

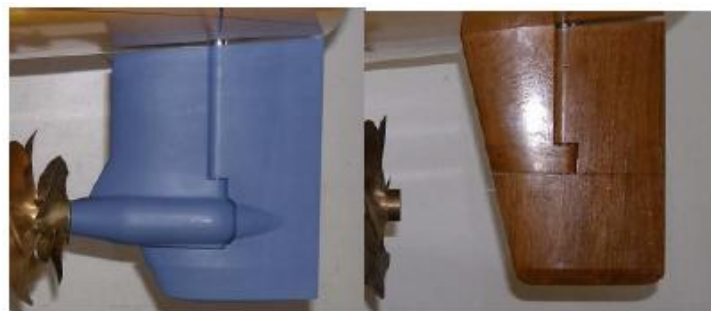

*Figure 3.1.3.3.- Comparison of areas and rudder axis location*

Numerical computations were made for the optimization of the pod housing used in a CRP propulsion unit. RANS code FINFLO is used to simulate the flow around the pod housing. The propeller has been modeled by potential-flow actuator-disk theory. The actuator disk is coupled with the RANS solver and the flow solution is sought in an iteratively way. The estimated propeller loads are transferred from the potential to the viscous solver. Conversely the estimated effective wake is transferred in the reverse direction to the propeller potential flow solver. The propeller loads are expressed in terms of body forces.

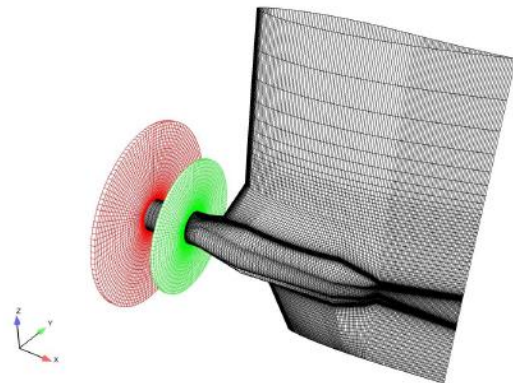

The computations shows a significant reduced viscous drag for the ABB profile relative to the NACA 66 modified or NACA four digit profiles. The drag of the Rudderpod is larger than that of the original rudder, but is expected to be overcome by the improvement in efficiency of the CRP unit.

The ABB profiles present also smoother and larger pressures on the strut suction side, which would result in an improved cavitation behavior.

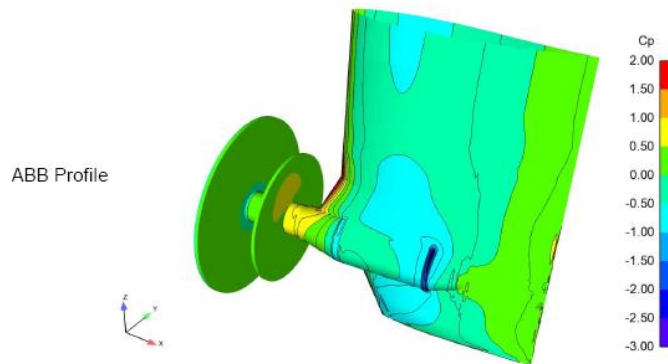

**Figure 3.1.3.4.- Pressure distributions on the port side of Rudderpod showing the location of the actuator disks.**

### 3.1.4.- Design of the propellers for Contra-Rotating configurations

Seven propellers have been designed for the different alternatives studied in TRIPOD, that added to the original propeller formed a set of eight propellers tested as explained in section 2.2 in this report. It is known that, in spite of the advances in the theories and design methods of propellers, even in the case of conventional propellers it is usual to perform two, three or more designs before reaching a final solution for one case. It has been very important that the propeller designs performed by SISTEMAR have result very accurate to the design requirements so useful comparisons have been possible.

According to the project schedule and due to the time needed for development of new dynamometers and instrumentation practically all designs had to be done before to know the results of any combination in contra-rotating configuration.

In simple retrofit scenario the reference ship hull form has been kept as it was, but the original horn rudder is removed and RudderPod installed. The main propeller is the same as in original vessel and its location related to hull remained the same. RudderPod propellers CONV3 and CLT3 were designed in simple retrofit scenario, CRP configuration, with following criteria:

- ✚ Design load condition corresponds to a draught of 12,200 m and  $T_{pp}-T_{pr}=0$  m.
- ✚ RPM ratio between forward propeller and RudderPod propeller is 1:1.167. This ratio is based on shaft generator and RudderPod electric motor pole number relation (12/10). This RPM relation is fixed throughout whole speed range.
- ✚ In RudderPod propeller design all precautions should be taken into account to prevent harmful cavitation and erosion on propeller blades.
- ✚ Power distribution between Forward and RudderPod propeller is approx. 80:20.
- ✚ The mechanical efficiency of the main engine transmission is 0,985 while the mechanical/electrical losses in the POD propeller are estimated in 6% ( $\eta_m = 0,94$ ).
- ✚ It was also decided within the members of this project to design propellers to 22 knots which will be realistic compromise in this case. The propeller efficiency level is rather stable from 13...15 knots upwards because the operation point of the propeller stays in stabilized conditions at same advance coefficient (J) in propeller open water curve. This selection of 22 knots as design point does not compromise propeller efficiency at 18...20 knots operation range.
- ✚ Strength is always dimensioned for full propulsion power.

Two CRP-pod units for the newbuilding scenario were designed, consisting in a new main conventional propeller (CONV2) and the RudderPod conventional (CONV4) and a new main CLT propeller (CLT2) and the RudderPod CLT propeller (CLT4). After some preliminary optimization and checking on the possibilities of combinations in the number of poles in electrical generator and motor the following criteria were adopted:

- ✚ Design speed and load condition are maintained.
- ✚ RPM ratio between forward propeller and RudderPod propeller is 1:0.7143. This ratio is based on shaft generator and RudderPod electric motor pole number relation (10/14). This RPM relation is fixed throughout whole speed range.
- ✚ In RudderPod propeller design all precautions should be taken into account to prevent harmful cavitation and erosion on propeller blades.
- ✚ Power distribution between Forward and RudderPod propeller is approx. 80:20
- ✚ Strength is always dimensioned for full propulsion power in the case of main propellers, and for a power of 8,5 MW in the case of RudderPod propellers as per the advice of ABB.

All the designs were made by SISTEMAR according to its procedures published in references [4] and [5].

### 3.2.- ENERGY SAVING

In relative terms the results of the four CRP-POD alternatives are also presented here below at different speeds:

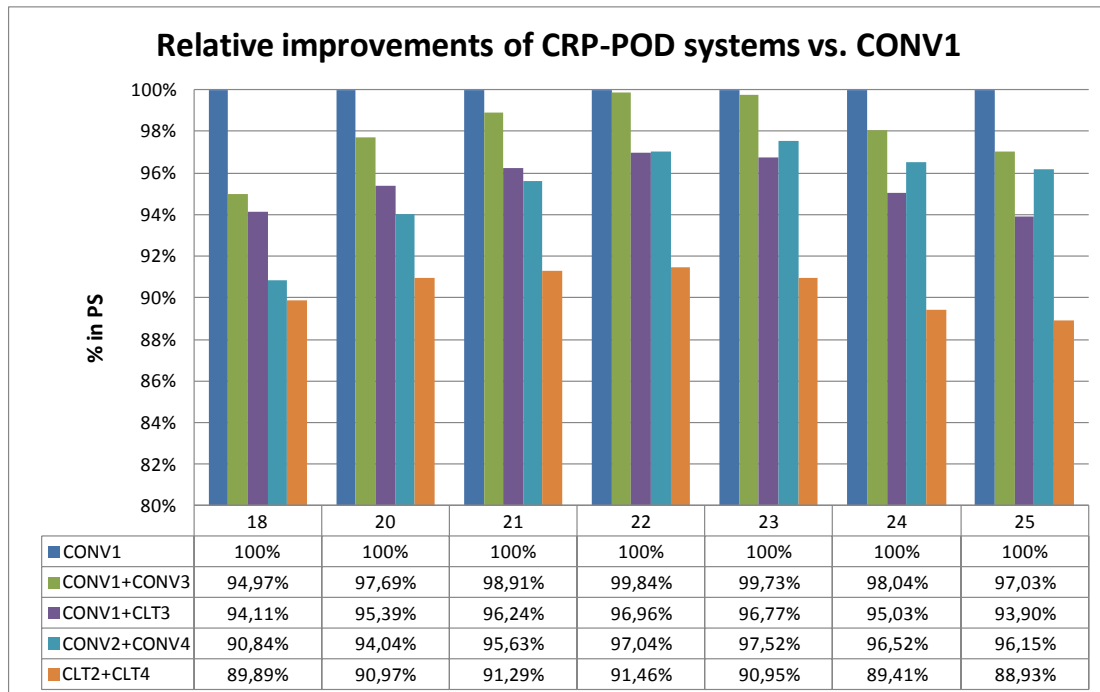

**Fig. 3.2.1.- Comparison in percentage of Power shaft needed.**

At all operational speeds CRP-POD systems developed generated higher efficiencies and consequently need to absorb less power from the main engine. That means that these systems will produce the possibility to sail at the same speed emitting less exhaust gases to the atmosphere.

Savings of more than 10% have been reached in the project with the only change of the propulsor versus a very well optimized conventional propeller. This is an outstanding result not easy to obtain by other means.

In particular CRP-POD systems with CLT propeller have shown a clear superiority over conventional propellers. This combination of Contra-rotating configuration, RUDDER-POD and CLT propellers have never been tested before, being its hydrodynamic development the main object of this project.

In spite of the complexity of the new developed system and the lack of knowledge existing prior to this project, all the innovative combinations have been designed with a high level of precision according to the obtained results.

### 3.3.- NOISE REDUCTION

One of the objectives of this project is the estimation of reduction of noise on the CRP-POD-CLT concept as compared to the conventional propulsion by a deep analysis of the model data focused on the case studies selected in previous WPs. This assessment has been made based in the analysis of the results of the cavitation tests performed with the new developed alternatives of CRP-POD propulsor systems for retrofit and for new building scenarios.

#### 3.3.1.- Brief Description of Cavitation Related Phenomena.

Most of propellers suffer cavitation at normal operation speeds and loading. Cavitation can produce a reduction on the propeller efficiency, erosion to the propeller and rudder, ship vibration and noise. The cavitation produces a continuous noise spectrum due to the great number of random small burst caused by bubbles collapse. The pressure pulses caused by bubbles cavities cover a frequency range from approximately 2-8 Hz up to 100 KHz and above. The lower frequencies are the cause of ship vibration which are generated during the growth and early collapse of bubbles. The highest frequencies of the spectrum and the higher risks of erosion are caused by the second part of the collapse when the velocity of the bubble wall may be near to the velocity of the sound in the water.

The lowest frequencies start at the blade passing frequency  $Z \times N$  being Z the number of propeller blades and N the propeller rps. The blade frequency and the few first multiples (harmonics) are associated with ship structural vibration. This vibration is the cause of internal noise onboard.

#### 3.3.2.- Reduction of Noise Actions.

Different aspects to reduce noise have been born in mind when developing TRIPOD project:

##### **Propeller tip clearance.**

New designed propellers with smaller diameter lead to large tip clearance. This implies that pressures fluctuating at the hull are smaller so the vibration levels at the stern are also lower which implies reduction of the noise levels on board.

##### **Shape of the stern. New hull design.**

For new building scenario hull form has been modified. The wake has been optimized. On figure 3.3.2 in blue color the wake of the modified hull may be observed. Red color represents the wake of the original hull. The uniformity of the wake has been improved. A minor gradient of the wake was obtained with the new hull at the upper angles of the screw propeller, where most of the cavitation was observed.



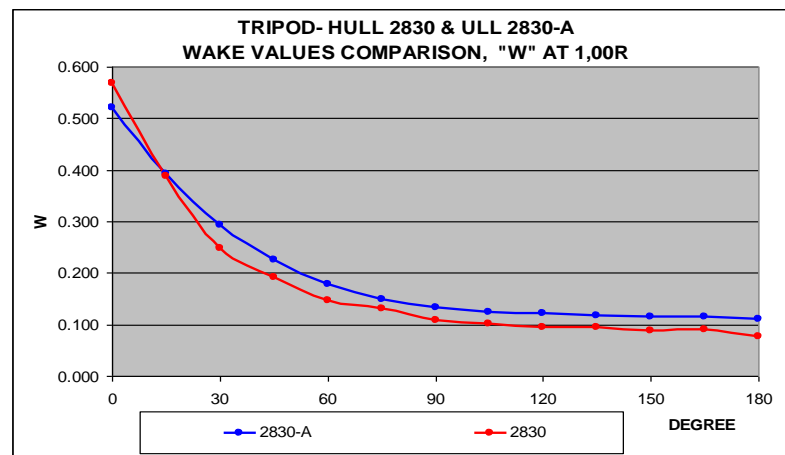
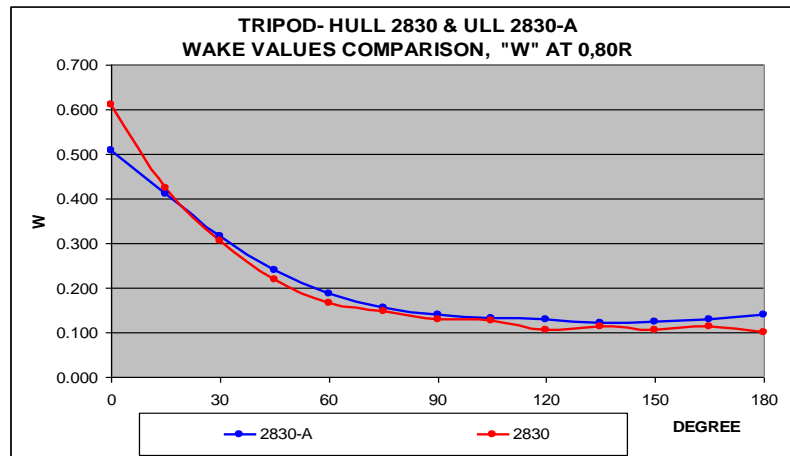

Figure 3.3.2.- Wake comparison at 0,8R and 1,0R sections.

The new wake implies an improvement of the cavitation pattern being cavitation observed more stable. The amplitudes of the first harmonic are lower. An improvement of the vibration induced and a reduction of internal ship noise is expected.

### Power reduction.

New designs of main propellers with lower power needed for the same speed at main propeller reduce cavitation effects. Less extension and intensity of propeller cavitation were observed during tests which imply reduction of noise.

### 3.3.3.- Summary of Pressure Pulses Measurements.

Cavitation observation and pressure pulses measurement tests have been carried out at the cavitation tunnel described in section 3.1.1 of this deliverable. Model pulses amplitudes (measured in kPa-kilopascals) for the first, second and third harmonics were measured corresponding to main and POD propellers for each set of tests in the Contra-Rotating Configuration (CRP); fourth and fifth harmonics have had in all cases very low amplitudes. The pressure pulses amplitudes of all harmonics induced by the pod propeller are negligible. All these results correspond to tests in design load condition.

Pressure transducers situation is represented in figure 3.3.3.1.

PRESSURE TRANSDUCERS SITUATION ON DUMMY MODEL

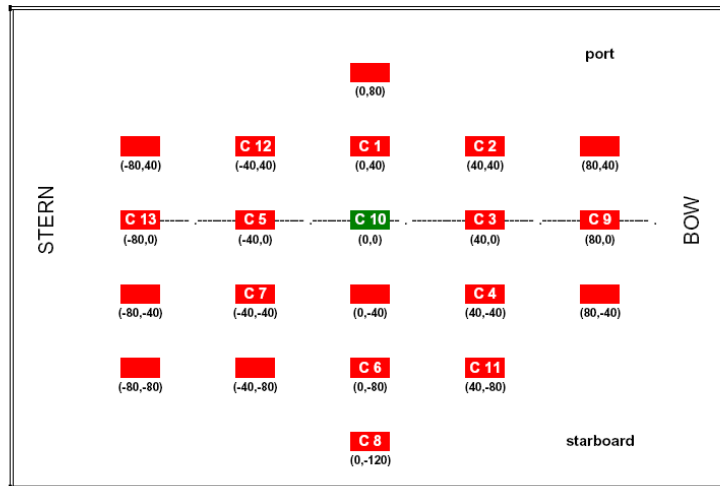

C10 IS SITUATED OVER THE TIP OF THE MAIN PROPELLER BLADE

Pressure transducers separation: 40 mm in both direction

Figure 3.3.3.1.- Pressure transducers situation.

Pulses amplitudes of CONV1 working in CRP configuration (power is reduced) with POD-CONV3 and with POD-CLT3 have lower values than CONV1 (original reference propeller without POD), although CONV1 amplitudes are quite low. See figures 3.3.3.2 to 3.3.3.5.

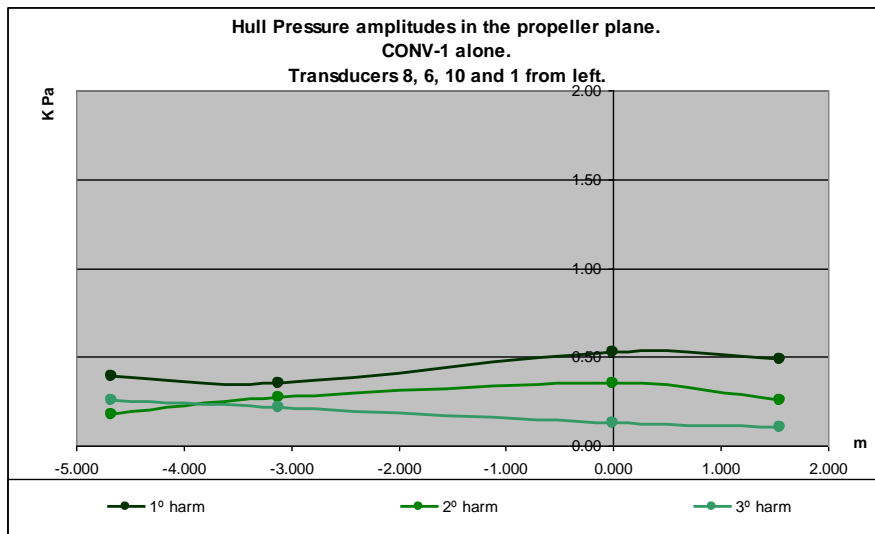
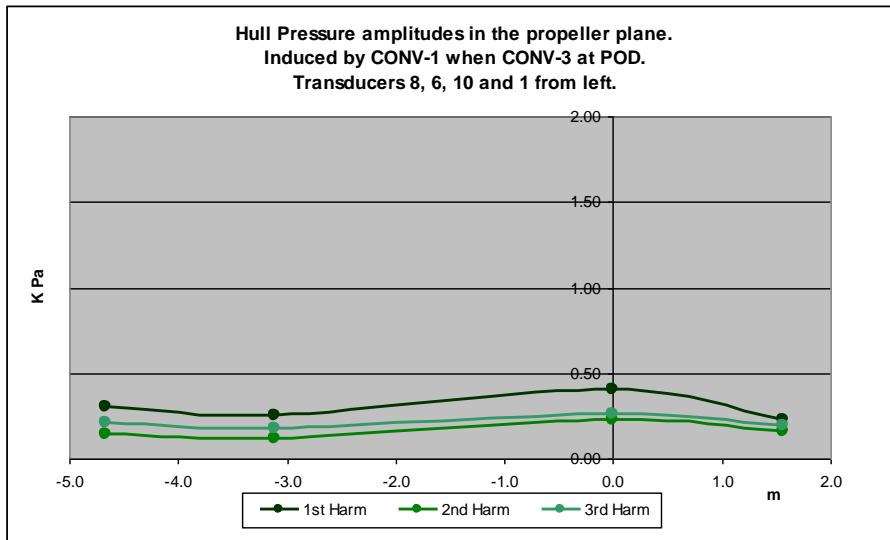
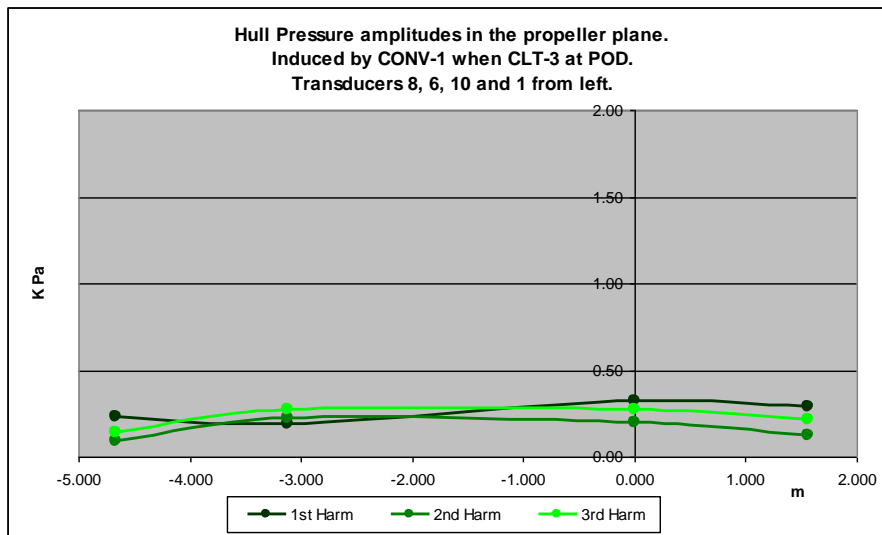

Figure 3.3.3.2.- CONV1 working alone.



*Figure 3.3.3.3.- CONV1 working in CRP with CONV3 at Pod.*



*Figure 3.3.3.4.- CONV1 working in CRP with CLT3 at Pod.*

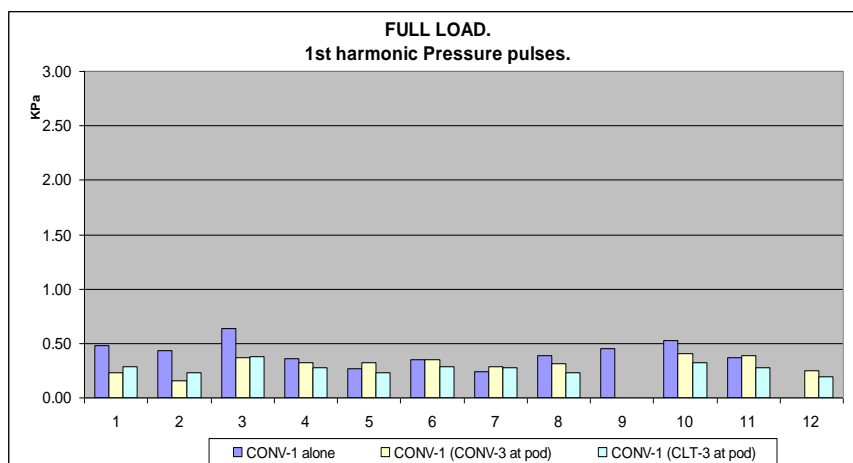

*Figure 3.3.3.5.- CONV-1 pressure pulse amplitudes.*

When CONV1 is working in the presence of any of both POD propellers, very moderate sheet and vortex cavitation has been observed. The cavitation behavior observed in CONV1 when is working with a POD propeller is even slightly better than the cavitation behavior observed in CONV1 when is working alone. See next figure 3.3.3.6.

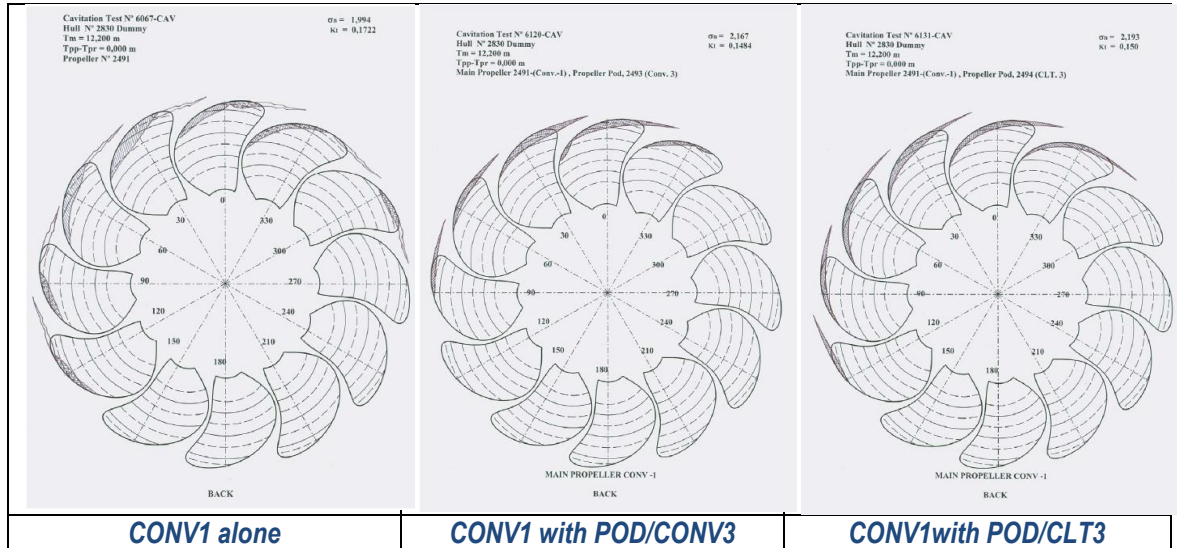

Figure 3.3.3.6.- Sketches of cavitation type and extension.

Pulses amplitudes of CLT1 working alone present higher values than CONV1. And CLT2 working in CRP configuration with POD/CLT4 (less power, more propeller tip clearance and new hull forms) presents similar values with a slightly different distribution. See next figure 3.3.3.7. In any case all the pressure pulses measured have very moderate values for this type of container ship.

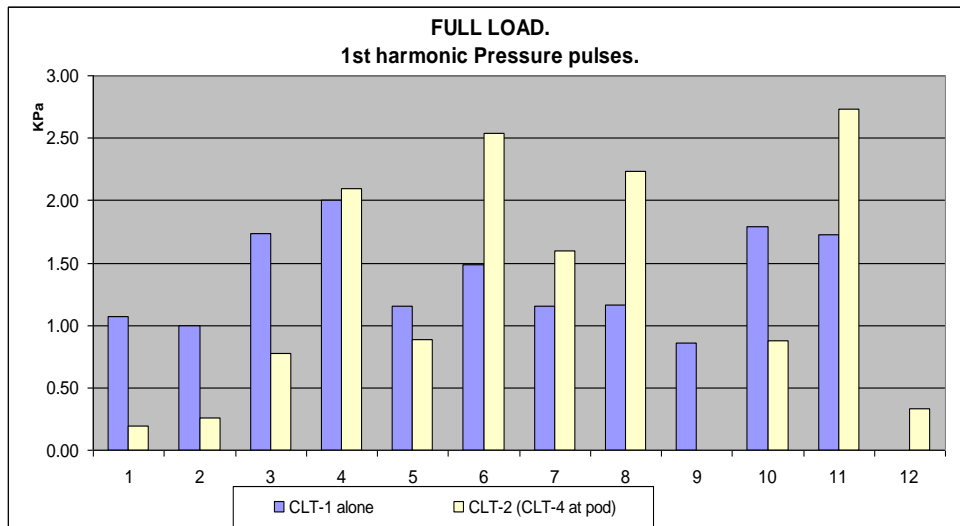
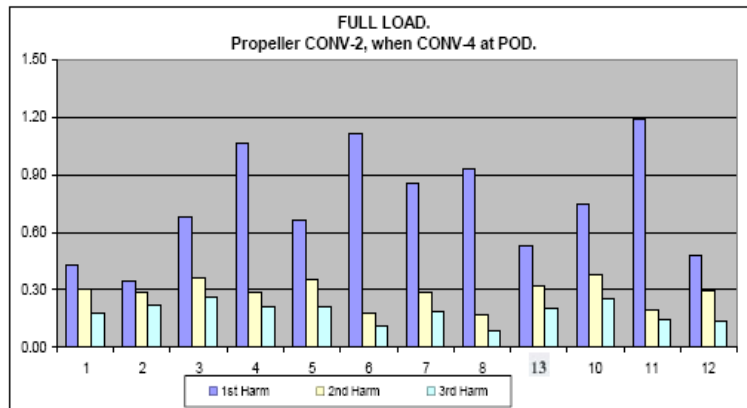
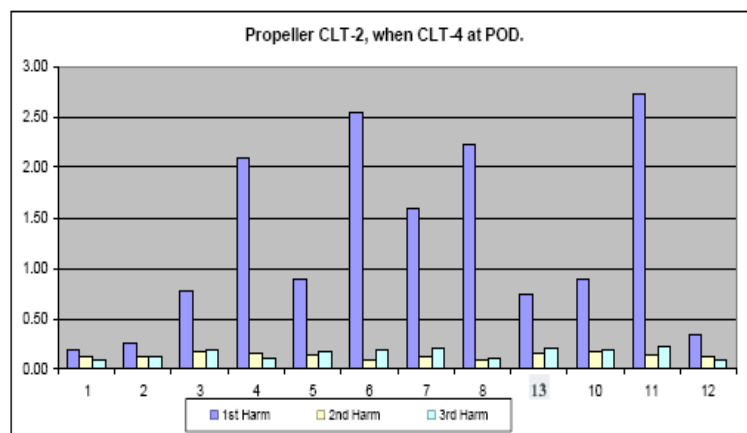

Figure 3.3.3.7.- Pressure pulses (1st harmonic) CLT1 and CLT2+POD/CLT4.



**CRP CONV2 with POD/CONV4**



**CRP CLT2 with POD/CLT4**

**Figure 3.3.3.8.- New building CRP configurations pressure pulses harmonics**

### 3.3.4.- Conclusions on Noise Reduction.

The analysis of the model cavitation observation tests and pressure fluctuations measurements show that the new developed concept CRP+POD and CLT propeller system has a good behavior in cavitation and presents moderate values of induced pressure pulses and correspondingly will be the internal airborne noise.

It clearly appears that the cavitation behavior of conventional propellers and CLT propellers is quite different. But comparing the main propeller working alone with the same main propeller working in CRP configuration with POD propellers, a reduction of pressure pulses induced to the hull have been recorded in CRP.

As conclusions, the new developed concept CRP+POD with CONV or CLT propellers have a promising behavior in cavitation mainly due to the combined effect of:

- ⇒ Improved wake flow of new hull form design. A more uniform wake distribution produces a better behavior of propellers in cavitation (less extension, more stable type of cavitation) generating smaller pulses to the hull.
- ⇒ Power share between main propeller and POD propeller reduces the load on main propeller, being optimum diameters smaller with larger hull clearances. The intensity of the pressure pulses reaching

the hull is inversely proportional to the magnitude of the clearance between the tip of the propeller and the hull.

⇒ POD propellers induce very low pulses, and in different frequencies, resulting in no significant levels of internal airborne induced noise.

#### 4.- Concept validation.

As has been already said the main objective of the TRIPOD Project is the development and validation of a new propulsion concept for improved energy efficiency of ships. TRIPOD explores the feasibility of a novel propulsion concept resulting from the integration of two promising technologies (podded propulsion and tip loaded endplate propellers) in combination with energy recovery based on counter rotating propeller (CRP) principle. The objective is to improve the ship propulsion efficiency through the advanced combination of these three existing propulsion technologies.

An existing cargo ship, the GUDRUN MAERSK, of more than 350 meters length between perpendiculars, has been selected to validate this concept. Such an impressive ship is operating to full satisfaction of the owner and is propelled with 6 blades optimum conventional propeller (CONV1) well adapted to the wake-flow of a very well studied hull form. To improve the propulsive performance of this ship is a true challenge for a novel propulsion concept.

The new concept CRP-POD-CLT propulsion system also has several advantages derived from the split of the power into two mechanically independent propellers, as for example the redundancy in propulsion. But the focus of TRIPOD Project is to improve the propulsive efficiency and consequently the amount of emissions to the atmosphere.

As has been explained in section 2 of this report tests have been oriented to obtain the best knowledge about the possible energy saving in two very realistic scenarios: in the case of retrofitting of the propulsion system of the existing ship and in the case of a new building ship.

Taken as reference the power prediction for CONV1 propeller the several alternatives tested results are reflected in the following table in relative percentages:

	Retrofit scenario				New ship scenario	
	Conventional		CRP Configurations			
	CONV1 /CONV1	CLT1 /CONV1	CONV1+CONV3 /CONV1	CONV1+CLT3 /CONV1	CONV2+CONV4 /CONV1	CLT2+CLT4 /CONV1
V, knots	%	%	%	%	%	%
14	100%	93,72%	98,03%	101,58%	88,81%	90,92%
16	100%	94,00%	95,47%	96,79%	90,19%	90,54%
18	100%	92,78%	94,97%	94,11%	90,84%	89,89%
20	100%	94,74%	97,69%	95,39%	94,04%	90,97%
21	100%	95,83%	98,91%	96,24%	95,63%	91,29%
22	100%	95,99%	99,84%	96,96%	97,04%	91,46%
23	100%	93,94%	99,73%	96,77%	97,52%	90,95%
24	100%	93,32%	98,04%	95,03%	96,52%	89,41%
25	100%	93,07%	97,03%	93,90%	96,15%	88,93%

**Table 4.- Relative power improvements of tested alternatives with respect to reference propeller.**

CRP-POD system has proved to be more efficient than a state of the art optimum conventional propeller as all the alternative CRP-POD systems developed have improved the ship propulsion power.

#### 4.1.- TRENDS IN PROPULSIVE COEFFICIENTS

Using the well known breakdown of the propulsive efficiency:

$$\eta_D = \frac{1-t}{1-w} \cdot \eta_0 \cdot \eta_R = \eta_H \cdot \eta_0 \cdot \eta_R = \eta_H \cdot \eta_B$$

Next figures will present the main trends deduced from the extensive programs of tests carried out for the different components of the propulsive efficiency.

In particular, CRP-POD alternatives developed in the new building scenario have better open water efficiency as they have been optimized without any kind of limitation, but hull efficiency which is a combination of suction and wake coefficients are slightly lower as compared with the results of CONV1 propeller (reference case).

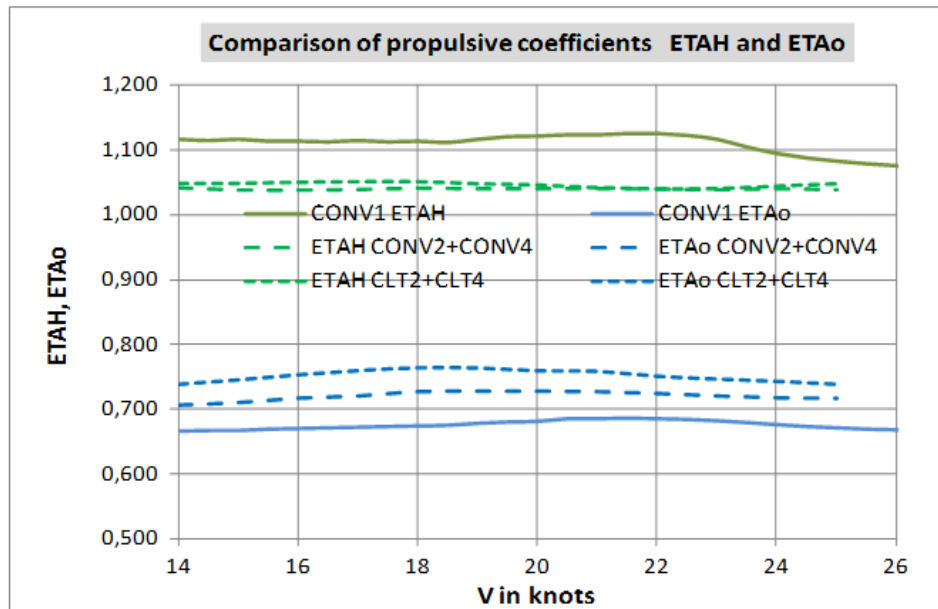

Figure 4.1.1.- New building scenario, ETAH and ETAo, CRP systems vs CONV1

CRP-POD systems tested show also a clear improvement in ETAR efficiency, probably meaning that the interaction hull-propeller has been improved. Combined with the improvement in ETAo give a more clear trend in the comparison of the behind efficiency ETAB.

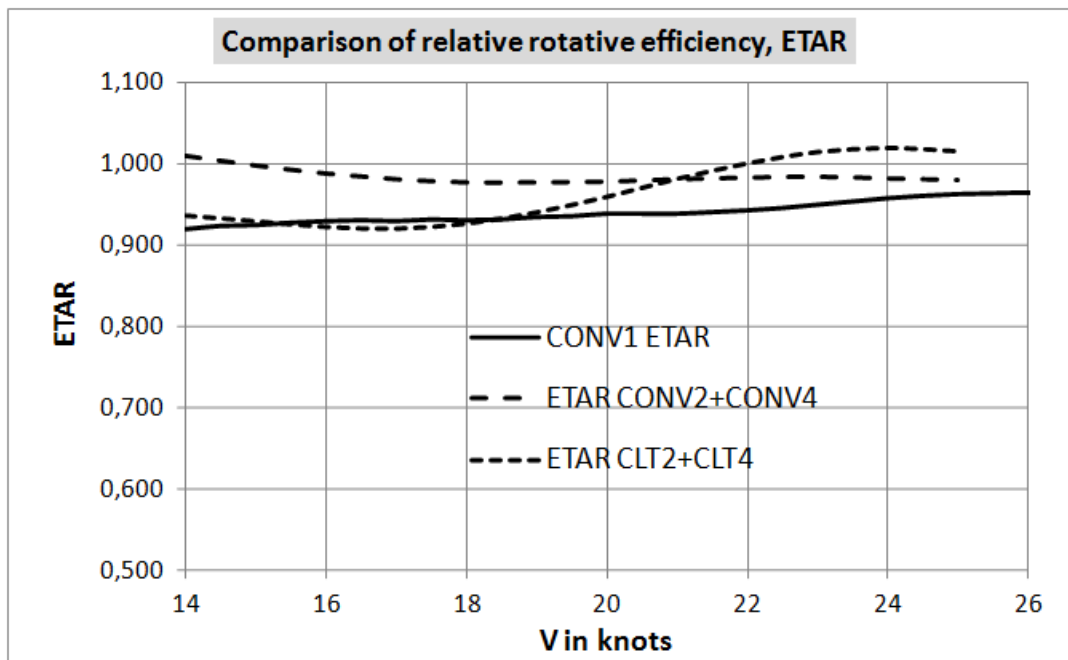

Fig. 4.1.2.- New building scenario, ETAR, CRP systems vs CONV1

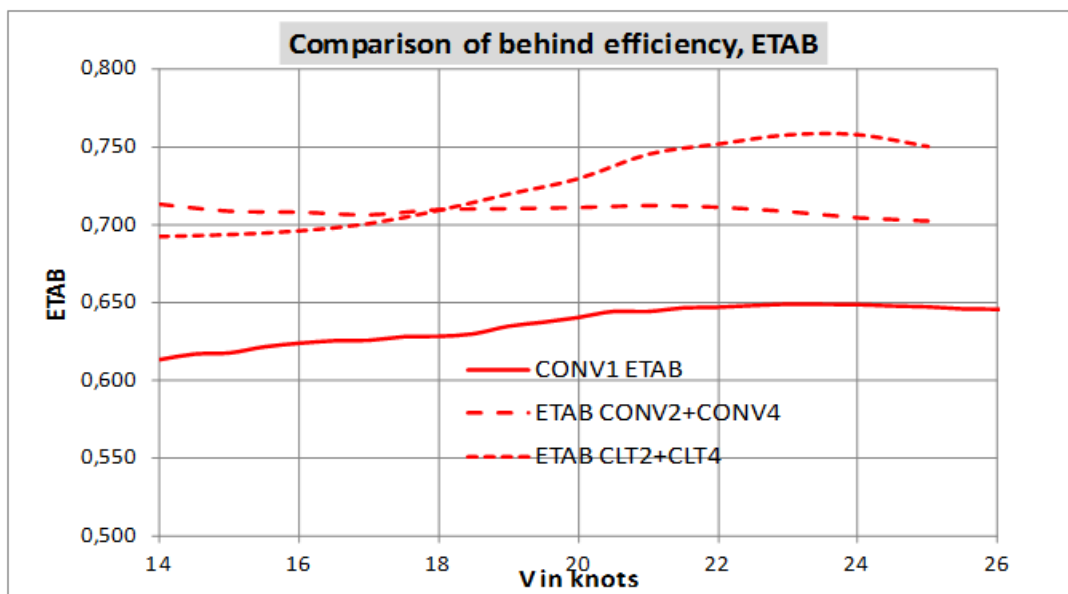
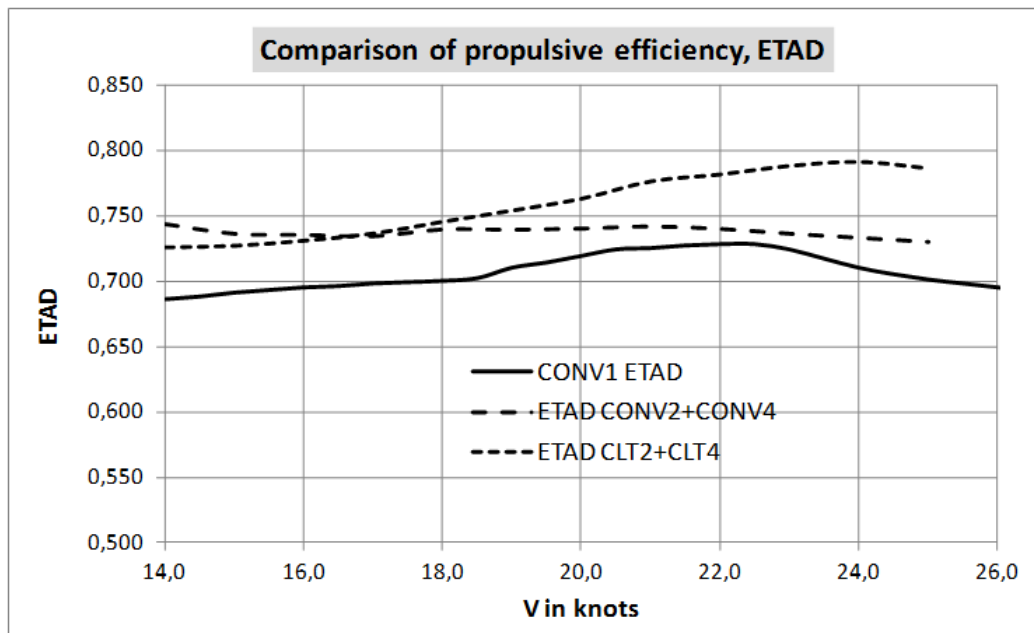

Fig. 4.1.3.- New building scenario, ETAB, CRP systems vs CONV1

It seems clear that CRP systems attain higher propeller efficiencies in behind condition than conventional propeller. This means that the new CRP-POD systems can be considered very promising from the point of view of energy savings and emissions reduction to be installed in ships with large power needs.

Next figure presents the values for the overall propulsive efficiency ETAD which is the product of all the others, as has been already explained.





*Fig. 4.1.4.- New building scenario, ETAD, CRP systems vs CONV1*

As conclusion the new CRP-POD system with CLT propellers have been validated with an extensive program of model tests showing that there are real possibilities to improve total propulsive efficiency of ships with high power demand.

#### 4.2.- ECONOMICAL ANALYSIS

A.P. MOLLER MAERSK is the end user partner of this project that has performed a detail economical analysis of different propulsion alternatives developed.

Economic criteria to analyze investment proposals are usually not written in stone. Hence the real economic criteria to evaluate business proposals vary from project to project, from business case to business case and from market situation to market situation. Acceptable payback times are very dependent on the global economic outlook and the business situation.

This means that proposals will need to be evaluated on their specific arguments, and on a case-to-case basis. Sometimes an investment proposal can be approved, provided that it creates value consisting of new knowledge, or future applications which might have a lower investment. Such arguments can be found in the various scenarios in the TRIPOD project as well.

Operational profiles of the existing ships like the reference ship used in TRIPOD project are changing in these years but not too much, so there are not a lot of differences expected when performing the economic analysis for 2010 or 2013.

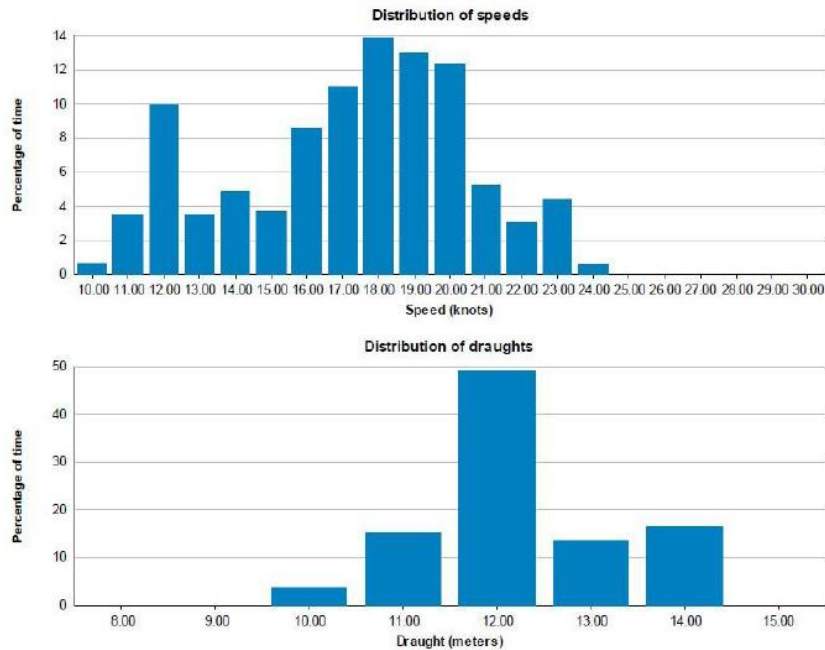

**Fig. 4.2.1.- Operational profile Gudrun class in 2010**

Comparing fuel savings with required CAPEX, it can be concluded that CLT alone is the most promising scenario with today's price levels. For a newbuilding project, the payback time is around 0.3 years, which is quite short. However for a retrofit, the payback time is around 3 years which is relatively long already.

The payback times for different RudderPOD newbuilding scenarios are between 6.9 and 8.5 years and for retrofit scenarios beyond the economic life of the ship. In case of a higher average vessel speeds, the newbuilding scenarios for RudderPOD become more attractive, especially the CLT2 + CLT4 scenario.

It must however be noted, that the tested propulsion configuration in TRIPOD is considered a state-of-the-art solution, which is technically very promising. It has a high potential in fuel savings and emission reductions. Especially for future newbuilding projects of the Maersk Group, it will be an interesting propulsion concept. And if the investment level can be brought down, obviously in close cooperation with the relevant specialist suppliers, Maersk will be interested to explore further installation opportunities in newbuilding projects of large container ships.

## REFERENCES

- [1] Quereda, R., Veikonheimo, T., Pérez-Sobrino, M., Ponce, J., Sánchez-Caja, A., Masip, J., González-Adalid, J., Uriarte, A., Nijland, M., Kokkila, K. 'Model testing and scaling for CRP POD'. 10th International Conference on Hydrodynamics, October 1-4, 2012 St. Petersburg, Russia.
- [2] Sanchez-Caja, A. & Pylkkänen, J. V., Prediction of Effective Wake at Model and Full Scale Using a RANS Code with an Actuator Disk Model. 2nd International Conference on Maritime Research and Transportation, Ischia, Italy, June 2007
- [3] M.Pérez Sobrino, E. Minguito Cardeña, A. García Gómez, J. Masip Hidalgo, L. Pangusion Cigales, G. Pérez Gómez, J. González-Adalid, Scale effects in model tests with CLT propellers, 27th Motor Ship Marine Propulsion Conference, January 2005.
- [4] G. Pérez Gómez, J. González-Adalid, Contrarotating and tandem CLT propellers, Propellers 94 SNAME (Virginia Beach), September 1994
- [5] G. Pérez Gómez, J. González-Adalid, Detailed design of ship propellers, FEIN, 1998.
- [6] A. Sánchez-Caja, J. González-Adalid, M. Pérez-Sobrino and I. Saisto, Study of End-Plate Shape Variations for Tip Loaded Propellers Using a RANSE Solver, 29th Symposium on Naval Hydrodynamics, Gothenburg, Sweden, 26-31 August 2012.
- [7] A. Sánchez-Caja, M. Pérez-Sobrino, R. Quereda, M. Nijland, T. Veikonheimo, J. González-Adalid, I. Saisto and A. Auriarte, Combination of Pod, CLT and CRP Propulsion for Improving Ship Efficiency: the TRIPOD project, Third International Symposium on Marine Propulsors smp'13, Launceston, Tasmania, Australia, May 2013.
- [8] Model Tests on the Manoeuvring and Course Keeping Performance of a Container Vessel with ABB RudderPod, HSVA Report 294, Hamburg 2011, Germany, Confidential
- [9] Model Tests with Conventional Propulsion and with RudderPod Propulsion for a Project Container Vessel, HSVA Report 72, Hamburg 2011, Germany, Confidential.