

VTT Technical Research Centre of Finland

## Liquid organic hydrogen carriers (LOHC)

Hurskainen, Markus

Published: 02/12/2019

*Document Version*  
Publisher's final version

[Link to publication](#)

*Please cite the original version:*

Hurskainen, M. (2019). *Liquid organic hydrogen carriers (LOHC): Concept evaluation and techno-economics*. VTT Technical Research Centre of Finland. VTT Research Report, No. VTT-R-00057-19



VTT  
<http://www.vtt.fi>  
P.O. box 1000FI-02044 VTT  
Finland

By using VTT's Research Information Portal you are bound by the following Terms & Conditions.

I have read and I understand the following statement:

This document is protected by copyright and other intellectual property rights, and duplication or sale of all or part of any of this document is not permitted, except duplication for research use or educational purposes in electronic or print form. You must obtain permission for any other use. Electronic or print copies may not be offered for sale.

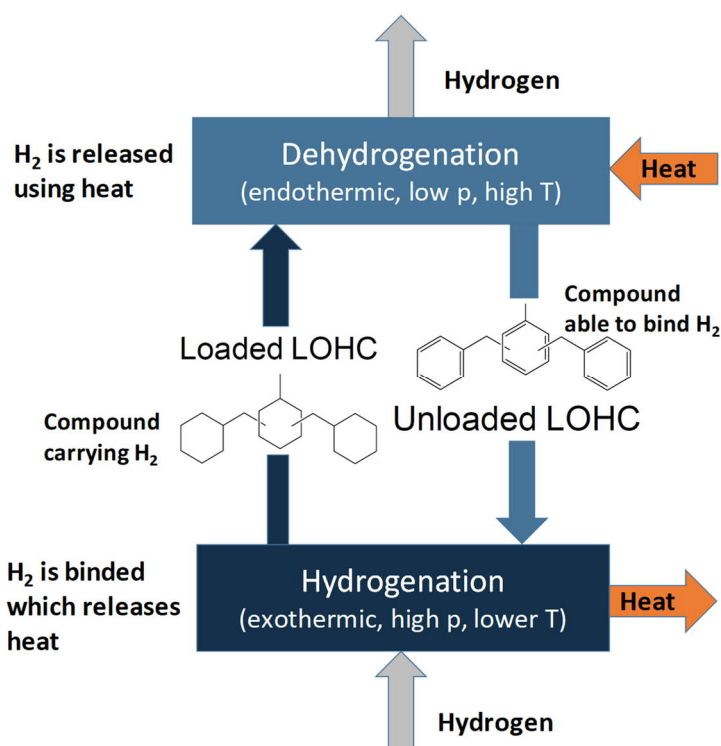

# Liquid organic hydrogen carriers (LOHC) - Concept evaluation and techno-economics

Authors: Markus Hurskainen

Confidentiality: Public

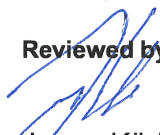
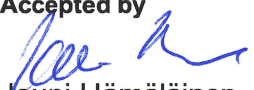
<b>Report's title</b>	
Liquid organic hydrogen carriers (LOHC) - Concept evaluation and techno-economics	
<b>Customer, contact person, address</b>	<b>Order reference</b>
Business Finland Porkkalankatu 1, Ruoholahti P.O. Box 69 FI-00101 Helsinki	Dnro 1508/31/2017
<b>Project name</b>	<b>Project number/Short name</b>
Liquid hydrogen "batteries" for storing renewable energy	115934/LOHCNESS
<b>Author(s)</b>	<b>Pages</b>
Hurskainen, Markus	60+app.
<b>Keywords</b>	<b>Report identification code</b>
Hydrogen, liquid organic hydrogen carrier, LOHC, energy storage, hydrogen logistics, by-product hydrogen	VTT-R-00057-19
<b>Summary</b>	
<p>Liquid organic hydrogen carriers (LOHC) are a promising solution for the efficient and safe storage and transportation of hydrogen, which have been the main hurdles for the realization of the hydrogen economy. The idea is to bind hydrogen to liquids from which hydrogen can be released reversibly returning the carrier liquid to its original state ready to be hydrogenated again. Although there are already some commercialization activities, LOHC systems are still an emerging technology having only a very limited number of technology providers and pilots. This report aimed to identify the advantages and possible limitations of the LOHC technology and evaluate the feasibility in the Finnish context.</p> <p>While the LOHC concept provides a means to transport and store hydrogen efficiently, safely and without storage losses, the high reaction enthalpies and high temperatures (~300–350 °C) required for releasing hydrogen were identified as possible challenges for the economics. Should hydrogen release be carried out by burning part of the hydrogen, ~30% of the hydrogen would be consumed. The equal amount of heat is released when hydrogen is bound but at lower temperature (~150 °C), and for economic feasibility it is important to find use for this heat. Equally important would be to utilise waste-heat to release the hydrogen but waste-heat with sufficient temperature is not often available. In future, the development of new LOHC compounds having lower reaction enthalpies and new catalysts for decreasing the dehydrogenation temperatures should be targeted.</p> <p>Generally speaking, the applications involving transportation of hydrogen and end-users using hydrogen as a reactant rather than an energy source were seen more economically attractive for the LOHC concept at least in the near-term. In the case studies, the logistics of by-product hydrogen from chlorate and chlor-alkali plants to light industry was identified as a possible low-hanging fruit for the LOHC concept to enter the markets. Also, should the need to import of renewable hydrogen from locations with high potential of renewable energy arise, the LOHC concept was found to be competitive against liquid hydrogen.</p>	
<b>Confidentiality</b>	Public
<p>Jyväskylä 2.12.2019</p> <p><b>Written by</b></p>  Markus Hurskainen, Research Scientist	
<p><b>Reviewed by</b></p>  Janne Kärki, Senior Scientist	
<p><b>Accepted by</b></p>  Jouni Hämäläinen, Research Team Leader	
<b>VTT's contact address</b>	
VTT Technical Research Centre of Finland Ltd, P.O. Box 1000, FI-02044 VTT, Finland name.lastname@vtt.fi, Tel. +358 20 722 7070	
<b>Distribution (customer and VTT)</b>	
Aino Energia, Fortum, Leppäkosken Sähkö, St1, Woikoski, University of Helsinki & VTT Ltd	
<p><i>The use of the name of VTT Technical Research Centre of Finland Ltd in advertising or publishing of a part of this report is only permissible with written authorisation from VTT Technical Research Centre of Finland Ltd.</i></p>	

## Preface

---

This report is a part of the jointly-funded Business Finland project LOHCNESS (Liquid hydrogen “batteries” for storing renewable energy) whose aim is to evaluate the performance and feasibility of the LOHC concept and to further develop catalysts and process components. The project is carried out during 2017–2019 and the partners involved are Aino Energia, Fortum, Leppäkosken Sähkö, St1, Voikoski, University of Helsinki and VTT Technical Research Centre of Finland Ltd.

This report aims to identify the advantages and possible limitations of the LOHC technology and evaluate the feasibility in the Finnish context in the selected applications.

Jyväskylä 2.12.2019

Authors

## Contents

---

Preface.....	3
Contents.....	4
1. Introduction.....	5
2. Structure of the report.....	6
3. Overview of hydrogen.....	7
3.1 Properties of hydrogen.....	7
3.2 Production and distribution.....	7
3.3 Storage.....	9
3.4 Utilisation.....	10
4. Liquid organic hydrogen carriers.....	11
4.1 The LOHC concept.....	11
4.2 Hydrogen purity.....	13
4.3 LOHC technology providers.....	13
4.4 Comparison of LOHC to other hydrogen storage options.....	15
4.5 Applications for the LOHC concept.....	16
5. Hydrogen in Finland.....	17
5.1 Hydrogen production and utilisation in Finland.....	17
5.1.1 Goal and methods.....	17
5.1.2 Results.....	17
5.2 Hydrogen production costs in Finland.....	22
5.3 Overall assessment of the most promising applications for the LOHC concept in Finland.....	26
6. Case studies on the feasibility of the LOHC concept.....	28
6.1 Introduction.....	28
6.2 Case 1: By-product hydrogen from chlor-alkali and chlorate plants to light industry.....	28
6.2.1 Overall case description.....	28
6.2.2 Hydrogen conversion / processing.....	32
6.2.3 Transport / trucking.....	34
6.2.4 On-site production of hydrogen.....	35
6.2.5 General assumptions.....	35
6.2.6 Results.....	36
6.2.7 Sensitivity analysis.....	39
6.2.8 Conclusions and discussion.....	41
6.3 Case 2 - Import of renewable hydrogen.....	42
6.3.1 Case description.....	42
6.3.2 Hydrogen production.....	43
6.3.3 Hydrogen conversion.....	43
6.3.4 Terminals.....	45
6.3.5 Sea transport.....	46
6.3.6 Hydrogen release.....	47
6.3.7 On-site hydrogen production at the refinery - SMR with CCS.....	48
6.3.8 Results.....	49
6.3.9 Sensitivity analysis.....	52
6.3.10 Summary and conclusions.....	54
7. Summary and conclusions.....	55
References.....	57
Appendix A. Hydrogen production – process flowsheets.....	60

## 1. Introduction

---

To prevent the disastrous climate change, CO<sub>2</sub> emissions need to be cut drastically in the near future. This necessitates the transformation from the current fossil carbon dependent system to a renewable based one. In this transformation, hydrogen is expected to play a major role as an energy carrier.

For the electricity sector the transformation will mean a marked increase in the shares of wind and solar energy. The intermittent and seasonal nature of wind and solar will pose new challenges for the energy system as the timing of production and consumption of electricity do not often meet. In addition, the most favourable regions for renewable energy production are often located far away from the places with the greatest energy demands. Thus, energy storage and transport solutions are needed when high shares of variable renewables are targeted and this is where hydrogen can come into play. Renewable electricity will likely play a significant role of decarbonising other sectors too. For example in transportation sector, direct electrification can be the solution for the majority of light transport but for aviation and maritime “indirect electrification” via hydrogen-based processes are required.

Significant amounts of fossil-based hydrogen is used today in different industry sectors (e.g. oil and chemical industry) and it needs to be produced sustainably in the future. In addition, hydrogen could substitute fossil feedstocks in new industrial sectors too. For example steel industry could shift from the currently dominant, coke-based blast-furnace process to a hydrogen direct reduced iron process. Furthermore, quite significant amounts of by-product hydrogen is currently just vented into the atmosphere due to lack of efficient means for transporting hydrogen.

Utilisation of elemental hydrogen requires dedicated infrastructures, and this has prevented so far the introduction of elemental hydrogen into the energy sector to a large extent (Preuster 2015). The main technical challenge with hydrogen is storage. For large-scale penetration of hydrogen, safe, efficient, practical and economical storage and transport solutions are needed (Aakko-Saksa 2018). One option, which has gained increased amount of attention lately, is to bind hydrogen to so-called liquid organic hydrogen carriers (LOHC) which can be cyclically hydrogenated and dehydrogenated. Unlike hydrogen storage by hydrogenation of gases, such as CO<sub>2</sub> or N<sub>2</sub>, hydrogen release from LOHC systems produces pure hydrogen stream and the liquid itself will be hydrogenated again. Hydrogen handling in the form of LOHCs would allow the utilisation of the existing infrastructure for liquid fuels. Thus, LOHC concept seems to be a promising option to enable wider use of hydrogen.

This report aims to identify the advantages and possible limitations of the LOHC technology and evaluate the feasibility in the Finnish context in the selected applications.

## 2. Structure of the report

---

The report is structured as follows:

- Chapter 3 gives a short general look on the properties, production & distribution and uses of hydrogen on a global level.
- Chapter 4 describes the status and characteristics of the LOHC technology.
- Chapter 5 shifts focus to Finland. The Finnish hydrogen market is mapped and analysed to find promising applications for the LOHC concept.
- Chapter 6 presents the techno-economic feasibility of the selected applications by means of case studies.
- Chapter 7 summarises the findings and draws conclusions.

### 3. Overview of hydrogen

#### 3.1 Properties of hydrogen

Under normal conditions, hydrogen is a colourless, odourless and non-toxic gas. The density of hydrogen in its gaseous state at NTP is only 0.089 g/l. Below its boiling point of  $-252.76\text{ }^{\circ}\text{C}$  (1 atm) hydrogen exists as liquid as illustrated in Figure 1. In the liquid state hydrogen has a density of 70.79 g/l (at the boiling point at 1 atm). Liquefaction increases the density of hydrogen by a factor of  $\sim 800$ .

One peculiar feature of hydrogen, which must be taken into account, is its negative Joule-Thomson coefficient meaning that it will heat up upon throttling from a higher to a lower pressure as opposed to “normal” gases which will cool down. Only below its inversion temperature ( $71\text{ }^{\circ}\text{C}$ ), will hydrogen demonstrate a “normal” Joule-Thomson effect. Typically the liquefaction of gases make use of the Joule-Thomson effect.

Being the lightest gas, hydrogen also has extremely high diffusibility: it can pass through porous materials or even metals. Special coatings can thus be required for storage containers to prevent diffusion and embrittlement of the materials.

Hydrogen is also an extremely flammable gas having a minimum ignition energy of 0.02 MJ. Compared to other fuels it is combustible in a very broad concentration range.

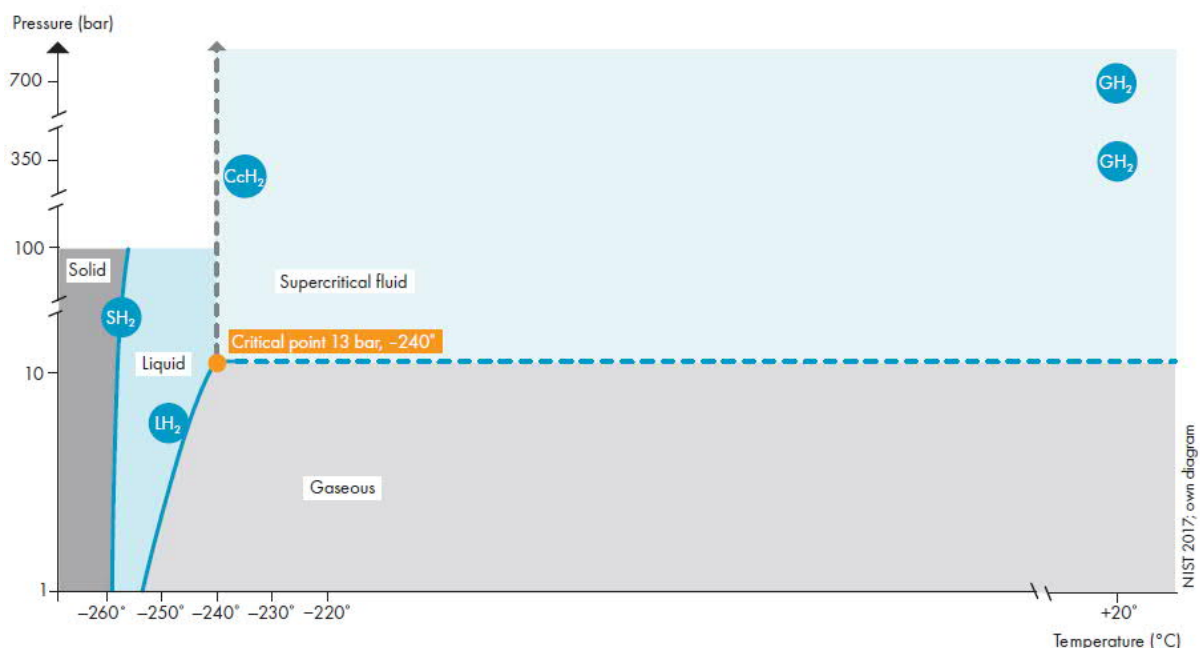

Figure 2. Phase diagram of hydrogen. (Shell 2017)

#### 3.2 Production and distribution

In nature hydrogen exists only in chemically bound form (e.g. as hydrocarbons). Thus, when molecular hydrogen is required, some conversion process is always required. Most commonly hydrogen is produced from natural gas by steam reforming<sup>1</sup> (Figure 3). Partial oxidation of fuel

<sup>1</sup> In the steam reforming process, natural gas is first combined with steam at high temperature and pressure in the presence of catalysts to produce a mixture consisting mainly of hydrogen and carbon monoxide. The subsequent shift reaction then converts the carbon monoxide and steam to hydrogen and carbon dioxide. Carbon dioxide is then separated from the stream.



oil and gasification of solid fuels are also used but to a lesser extent. Around 5% of hydrogen is produced from electricity via electrolysis.

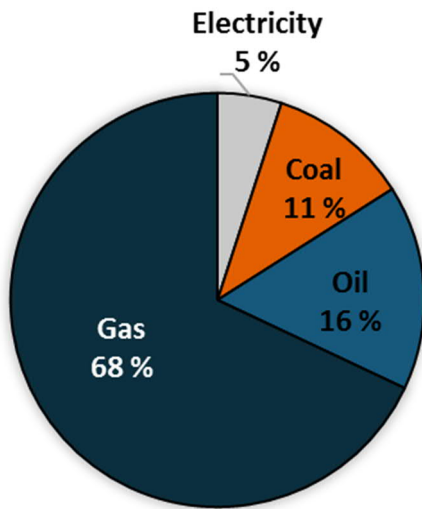

Figure 3. Share of primary energy carriers in global hydrogen production (Data from Shell 2017)

Hydrogen can be produced either in large centralised facilities and then delivered either via pipelines or trucks to end-user or it can be produced on-site eliminating the need to transport hydrogen (Figure 5).

Technologies benefiting clearly from the economies of scale, or which have other limiting boundary conditions e.g. on geographic location, are more suitable for centralised production. For example, large-scale SMR plants can have significantly lower specific CAPEX and also higher efficiency compared to distributed small-scale on-site plants. In addition, on-site plants would not necessarily have access to natural gas. Furthermore, in the future the plants using fossil fuels should have carbon capture and storage (CCS) units installed. CCS is not economical in small-scale and in most cases CO<sub>2</sub> would have to be transported long distances. Due to modularity, electrolyzers offer only minor benefits of economies of scale after around 2 MWe unit size making distributed production attractive more often.

For delivery the main options thus far have been 1) pipeline, 2) high pressure tube trailers and 3) liquid hydrogen tankers. Pipelines are the least-expensive way to deliver large volumes of hydrogen for short distances. Transporting compressed hydrogen gas by truck is most suitable for delivering small amounts of hydrogen for relatively short distances (<300 km). Liquefying enables hydrogen to be trucked more efficiently over long distances due to significantly higher payloads (Figure 4). However, due to extremely low boiling point of hydrogen liquefaction process is very expensive and has a high energy-requirement making it suitable only for large-scale plants (preferably >100 MW<sub>H<sub>2</sub></sub>). In addition, hydrogen delivery and consumption rates must be carefully matched to avoid boil-off from containment vessels.



Figure 4. Existing road transport options for distributing hydrogen. (Shell 2017)

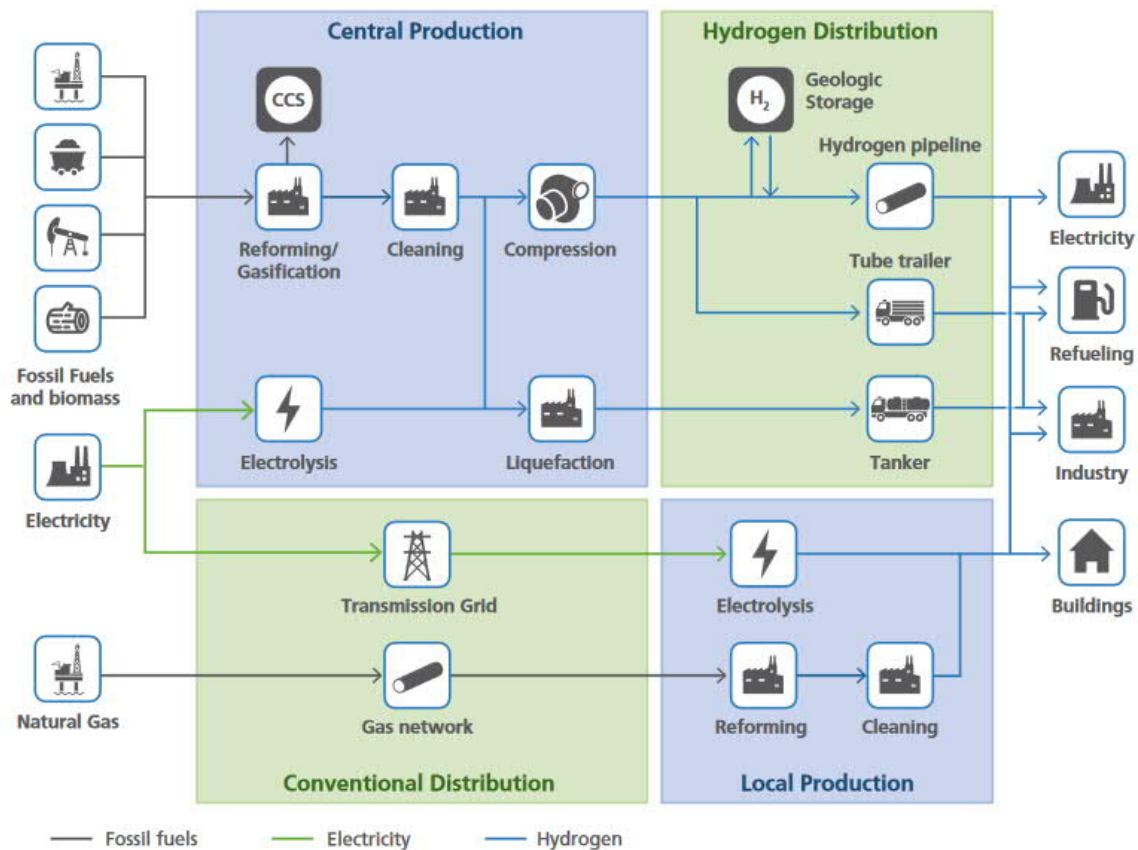

Figure 5. Options for hydrogen production and distribution. (Staffel&Dodds 2017)

### 3.3 Storage

Traditionally hydrogen has been stored either as compressed gas or liquid. When hydrogen demands are low, hydrogen can be stored in stationary vessels at low pressures (around 50 bar), or multi-cylinder pallets and pressure tubes for medium and high pressures (200 to even 700 bar). (E4tech 2015) Even at 700 bar hydrogen the volumetric energy density is low (5.0 MJ/l, 40 g/l) and storage density even lower. (Aakko-Saksa *et al.* 2018)

Salt caverns, lined rock caverns, exhausted oil and gas fields and aquifers could be used for industrial scale long-term storages for compressed hydrogen. Hydrogen storage in salt caverns is well proven in the UK: the caverns in Teesside have been operational since the 1960s. (E4tech 2015)

Liquid hydrogen (LH2) storage is also an established technology. Liquid hydrogen tanks can store more hydrogen in a given volume than compressed gas tanks but less than liquefied natural gas (volumetric energy density of LH2 is 8.5 MJ/l compared to LNG's 21 MJ/l. On the other hand, liquefaction of hydrogen requires significantly higher electricity input compared to compression. While compression from 1 to 350 or 700 bar requires electricity inputs in the range 9–12% of the final hydrogen energy content, liquefaction takes around 30%. (Shell 2017)

It is noteworthy that storing hydrogen in liquid form leads to boil-off losses. The amount of boil-off losses will depend on the storage size and insulation. For a 50 m<sup>3</sup> tank boil-off losses are typically around 0.4% in a day while 20 000 m<sup>3</sup> tank would have boil-off loss of <0.06% (U.S. Drive 2013).

### 3.4 Utilisation

Globally industry uses around 7.7 EJ (2140 TWh) of hydrogen annually. Half of the hydrogen is used for producing ammonia while oil refining accounts for roughly one third (Figure 6). In oil refining hydrogen is used in e.g. in hydrocracking and hydrotreating. Significant amounts of hydrogen is used also for the production of methanol (11%) while other chemicals and steel & glass sectors account only for a small share of the total consumption. (Hydrogen council 2017)

Hydrogen utilisation is expected to increase significantly in future as use in transportation, energy production (incl. storage) and new industrial processes will become more common. Also, the demand for hydrogen in refineries is expected to increase due to decreasing quality of crudes and increasing quality requirements (e.g. sulphur content) of the processed fuels. In addition, the use different biobased feedstocks in refining is expected to increase hydrogen demand. (Shell 2017) Hydrogen council estimates that hydrogen utilisation could increase 10-fold by 2050 (Figure 7).

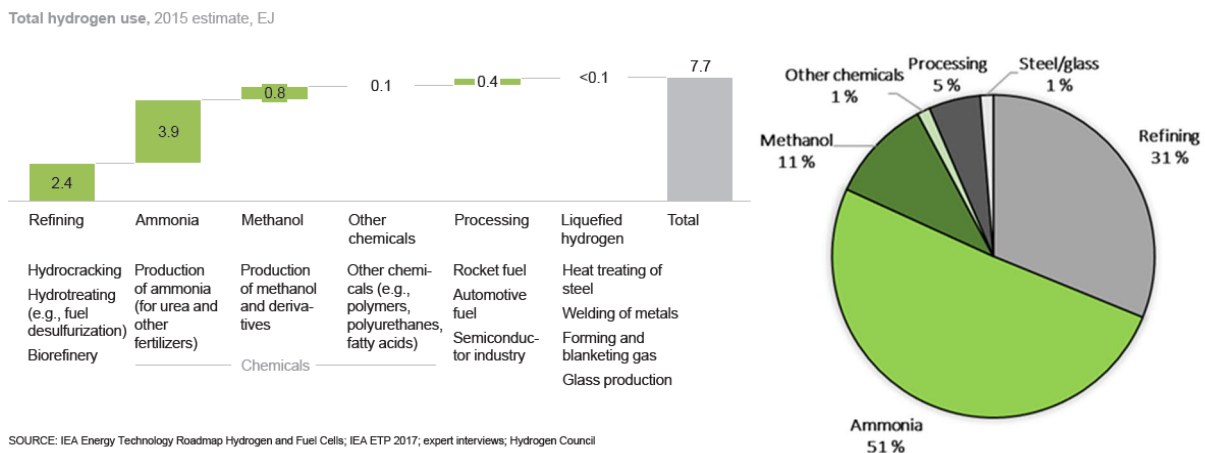

Figure 6. Estimated global use of hydrogen in industry in 2015. (Hydrogen council 2017)

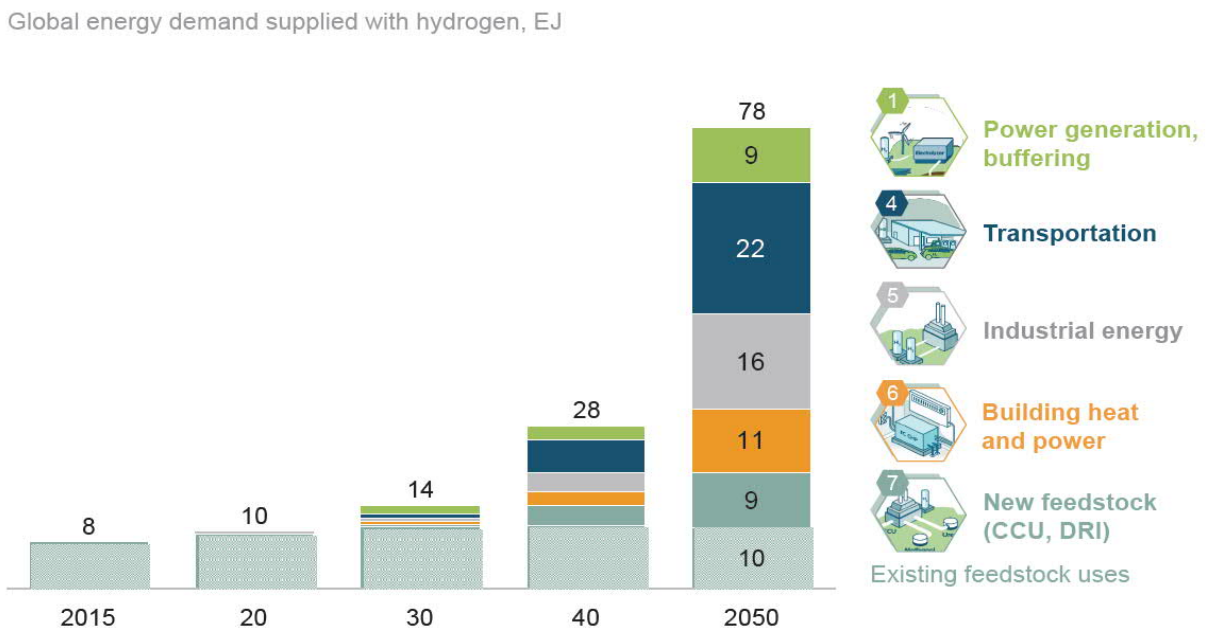

Figure 7. Possible increase in hydrogen utilisation in the future. (Hydrogen council 2017)

## 4. Liquid organic hydrogen carriers

### 4.1 The LOHC concept

Liquid organic hydrogen carriers (LOHCs) are liquids that can be reversibly hydrogenated and dehydrogenated. During dehydrogenation hydrogen is released as the sole product and the carrier liquid will be returned to its original state ready to be hydrogenated again. Figure 8 illustrates the basic principles of the LOHC concept.

Hydrogenation step is exothermic (meaning that heat is released in the reaction) and it is typically carried out at elevated temperatures (100–240 °C) and pressures (10–50 bar) with the presence of catalysts (Aakko-Saksa 2018).

The same amount of heat is then required in the endothermic dehydrogenation step to release hydrogen. Catalytic dehydrogenation is typically carried out at 150–400 °C and pressures below 10 bar. (Aakko-Saksa 2018)

One of the advantages of the LOHC concepts is that the LOHCs are compatible with the existing fuel infrastructure. Furthermore there is no hydrogen loss even in the long-term storage or when transported overseas at normal conditions. For example liquid H<sub>2</sub> delivery chains have significant boil-off losses.

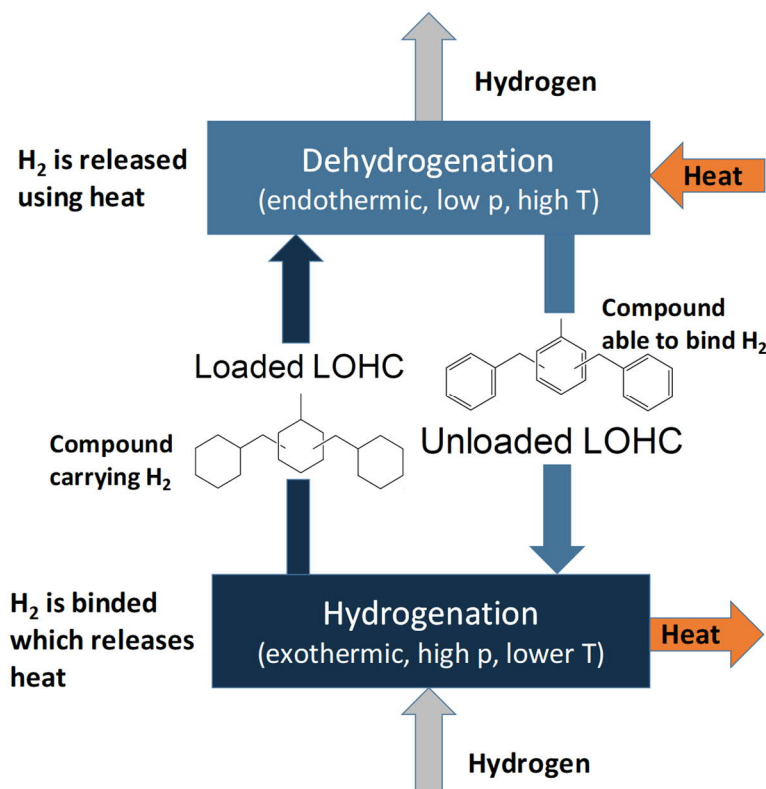



Figure 8. Illustration of the LOHC concept.

There are several different LOHC compounds under research. For example aromatic hydrocarbons or heterocyclic compounds such as carbazoles, pyridines or pyrroles could be used as LOHCs. These have been recently reviewed by Aakko-Saksa *et al.* 2018. Ideal LOHC would have high hydrogen storage density, low reaction enthalpy, low degradation and it would be non-toxic, cheap and have high enough melting point to stay in liquid form also in cold conditions. Furthermore, the conversion reactions would take place at moderate conditions

using low-cost catalysts. Lately most attention has been paid to dibenzyltoluene–perhydrodibenzyltoluene (H0-DBT–H18-DBT), toluene–methylcyclohexane (TOL–MCH) and N-ethylcarbazole–dodecahydro-N-ethylcarbazole (NEC–H12-NEC) systems, whose main properties are compared in Table 1.

Table 1. Comparison of the main properties of the most developed LOHCs (Schneider 2015)

Property		Dibenzyltoluene–perhydrodibenzyltoluene (DBT-H18-DBT)	N-Ethyl-Carbazole-dodecahydro-N-ethylcarbazole (NEC-H12-NEC)	Toluene–Methylcyclohexane (TOL–MCH)
Storage density		2.05 MWh/Nm <sup>3</sup>	2.01 MWh/Nm <sup>3</sup>	1.58 MWh/Nm <sup>3</sup>
Melting point / boiling point	Loaded	-39 °C / 390 °C	69.1 °C / 348 °C	-95 °C / 111 °C
	Unloaded		/ 280 °C	-127 °C / 101 °C
Hydrogenation	Pressure	30–50 bar	70 bar	10–50 bar
	Temperature	150 °C	150 °C	50–100 °C
	Reaction enthalpy	-65 kJ/mol H <sub>2</sub> (27% of H <sub>2</sub> LHV)	-53 kJ/mol H <sub>2</sub> (22% of H <sub>2</sub> LHV)	-68.3 kJ/mol H <sub>2</sub> (28% of H <sub>2</sub> LHV)
Dehydrogenation	Pressure	1 bar	1 bar	3 bar
	Temperature	320 °C	220 °C	350 °C
	Reaction enthalpy	65 kJ/mol H <sub>2</sub> (27% of H <sub>2</sub> LHV)	53 kJ/mol H <sub>2</sub> (22% of hydrogen LHV)	68.3 kJ/mol H <sub>2</sub> (28% of hydrogen LHV)
Toxicity		-		
Flammability		Low	Low	High
Price		<4 €/kg	>\$40 /kg	<1€/kg

One distinct feature of the LOHC concept are the high reaction enthalpies (Table 1) meaning that significant amount of heat is required to release the hydrogen. Considering the inevitable heat transfer losses, ~25–30% of the released hydrogen would have to be burned should the heat be provided by hydrogen. Furthermore as the required temperature level is quite high, it is not possible to use low-value waste-heat sources in most cases. However, it should be borne in mind that the same amount of heat is released during hydrogenation; although at a lower temperature level. If this heat can be utilised, the energy penalty for dehydrogenation can be at least partially compensated.

One additional drawback of the LOHC concept is the low pressure of the dehydrogenation step. In cases where high pressure hydrogen is required – e.g. bottle filling stations or mobility applications – this incurs a major energy penalty for compression. Electrolysers can produce up to some 30–50 bar with only a minor additional energy penalty compared to atmospheric operation.

Dibenzyltoluene (DBT), which been recently commercialized by Hydrogenius GmbH, was seen as the most promising option and was selected as the LOHC for this study. DBT offers high storage density, is widely available at reasonable price (commercial heat transfer fluid marketed under the trademark Marlotherm) and it has a low melting point. Other options were not considered as the focus of the report is in the applications of the LOHC concept rather than comparing different LOHCs.

## 4.2 Hydrogen purity

Hydrogen released from LOHCs has a relatively high purity. For DBT-based systems purity 4.0 (99.99 vol%) is achievable just by cooling the gas/vapour stream in a dephlegmator which condenses the part of the LOHC that left the reactor as vapour. The remaining impurities are mainly water and hydrocarbons, which form as decomposition products of the LOHC. The most relevant remaining impurities are methane, toluene and benzyltoluene. (Arlt 2017)

Purity requirements for different uses vary. While 99.99% purity is sufficient for many uses, the limits for PEM fuel cells are much more stringent. For example the ISO 14687-2 states that maximum concentration of hydrocarbons in the hydrogen stream is 2 ppm. It might be necessary to implement additional (and a lot more expensive) purification steps to comply with this limit when LOHC systems are used. However, not all of the hydrocarbons are equally harmful to the PEM membrane and thus, distinction should be made for the various compounds in the limit values. In addition, as the current standards have been made having the current hydrogen production processes in mind, the limit values refer frequently to substances that typically occur in the provision of hydrogen from fossil sources. Further research is therefore required to determine the actual purity requirements for the PEM fuel cell use of LOHC-based hydrogen after which the standards should be updated. (Arlt 2017)

## 4.3 LOHC technology providers

Although there are already some commercialization activities, LOHC systems are still an emerging technology with only a very limited number of technology providers. While hydrogenation of aromatics and dehydrogenation of cyclic hydrocarbons are mature industrial processes in oil refining, using LOHCs in smaller-scale will require different processes and catalysts with priority on the safety, robustness and fast kinetics (Aakko-Saksa 2018).

In addition to Hydrogenious GmbH, at least H2-Industries AG and Hynertec are also LOHC-based solutions and Areva H<sub>2</sub>Gen is also involved in LOHC development. In Japan, LOHC system based on toluene is being demonstrated by Chiyoda Corp.

Hydrogenious GmbH currently offers small-scale containerized LOHC units with capacities in the range of 5–100 Nm<sup>3</sup>/h (15–300 kW). Their units utilize dibenzyltoluene (DBT) as the carrier compound.

H2-Industries (<http://www.h2-industries.com>) offers modular LOHC-based Power-to-Power solutions. The storage units consist of an electrolyser and a hydrogenation unit while the release unit has a dehydrogenation unit accompanied by a fuel cell. In addition, various sizes of storage tanks and silos are available. The capacities for the storage units range from 66 to 1 650 kW of input electricity, which corresponds to roughly to 45–1 100 kW (15–550 Nm<sup>3</sup>/h) of stored hydrogen based on the lower heating value (LHV). The release unit capacities are 66–1 650 kW of output electricity. Assuming 50% efficiency for the fuel cell, dehydrogenation capacity is 130–3 300 kW. H2-Industries do not explicitly say which LOHC compound they are using.



Figure 9. One of the many solutions offered by H2-Industries.

Areva H<sub>2</sub>Gen (<http://www.arevah2gen.com>) is a French equipment manufacturer that produces Proton Exchange Membrane (PEM) electrolyzers but they have also been involved in developing LOHC solutions. However, they are not offering any LOHC equipment at the moment.

Hynertech (<http://www.hynertech.com/en/>) is a Chinese company that supplies 1–50 kW high purity hydrogen supply systems for mobile and stationary applications. The company says it provides “uniquely designed hydrogenation systems with various capacities using LOHC materials” and “patented LOHC compounds as hydrogen storage media”.

Chiyoda Corporation (<https://www.chiyodacorp.com/en/service/spera-hydrogen/>) is currently aiming to demonstrate world’s first international hydrogen supply chain based on their SPERA LOHC concept, which uses toluene as the carrier compound. In 2020 hydrogen will be produced in Brunei, bound in toluene and then transported by ship to Kawasaki, Japan. Hydrogen will be produced by steam reforming of natural gas. The scale of the project is said to be 210 tons (max), equivalent to filling 40,000 fuel cell vehicles but it is unclear what will be the hydrogen output (Nm<sup>3</sup>/h). The technical feasibility of hydrogenation and dehydrogenation of the system was successfully demonstrated earlier (2013–2014) in small-scale (50 Nm<sup>3</sup>/h) for 10 000 hours.

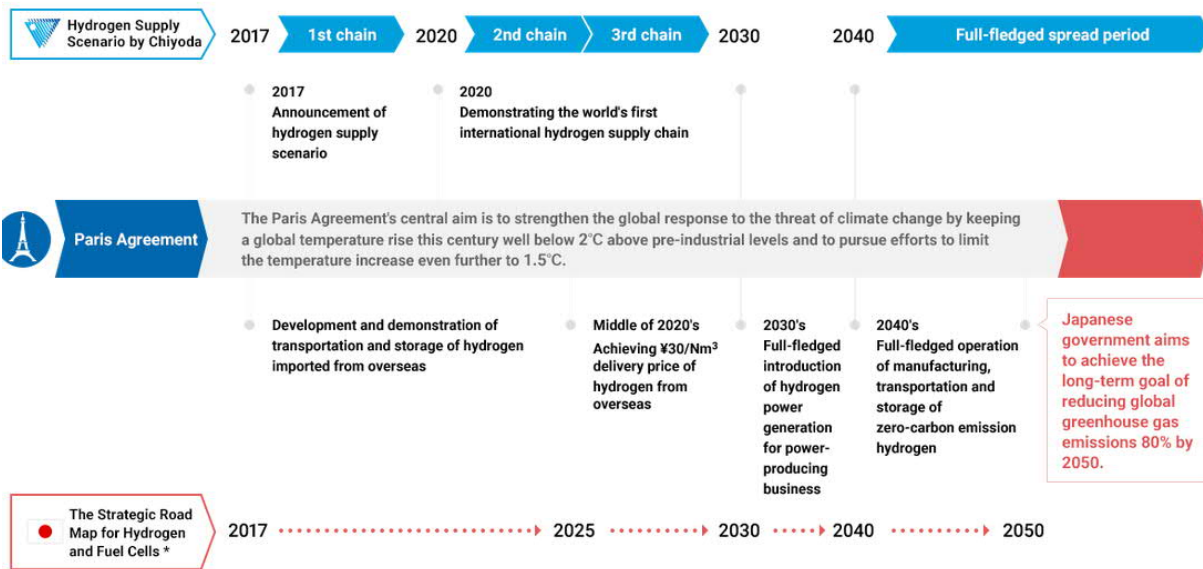

Figure 10. Chiyoda’s roadmap for their toluene-based LOHC concept. (Courtesy of Chiyoda)

#### 4.4 Comparison of LOHC to other hydrogen storage options

Elemental hydrogen can be stored either as high pressure gas or as liquid both of which have their own limitations. Compressed gas in cylinders is suitable only for small-scale applications and it suffers from low storage density (when the weight of the storage vessel is also considered). (Figure 11) Liquid H<sub>2</sub> has boil-off issues and liquefaction is both capital and energy intensive process which requires large-scale liquefaction facilities to be economically viable.

To avoid issues with handling and storing elemental hydrogen, there are also other options besides binding hydrogen to a LOHC. Hydrogen can also for example be combined with nitrogen to obtain ammonia or with carbon dioxide to produce methane, methanol or liquid hydrocarbon products. These so-called non-reversible circular hydrogen carriers would have significantly higher storage densities compared to LOHC and some of them would be compatible with existing infra. In addition, for example utilisation of ammonia would involve significant safety concerns. (Aakko-Saksa *et al.* 2018).

For energy purposes non-reversible circular energy carriers could be used as such but hydrogen can also be released in the corresponding reverse reaction. However, either N<sub>2</sub> or CO<sub>2</sub> would be formed as a by-product which would necessitate an additional separation step compared to releasing hydrogen from LOHC. Thus, the applications which require hydrogen as raw material seem to offer benefits for LOHC compared to circular energy carriers.

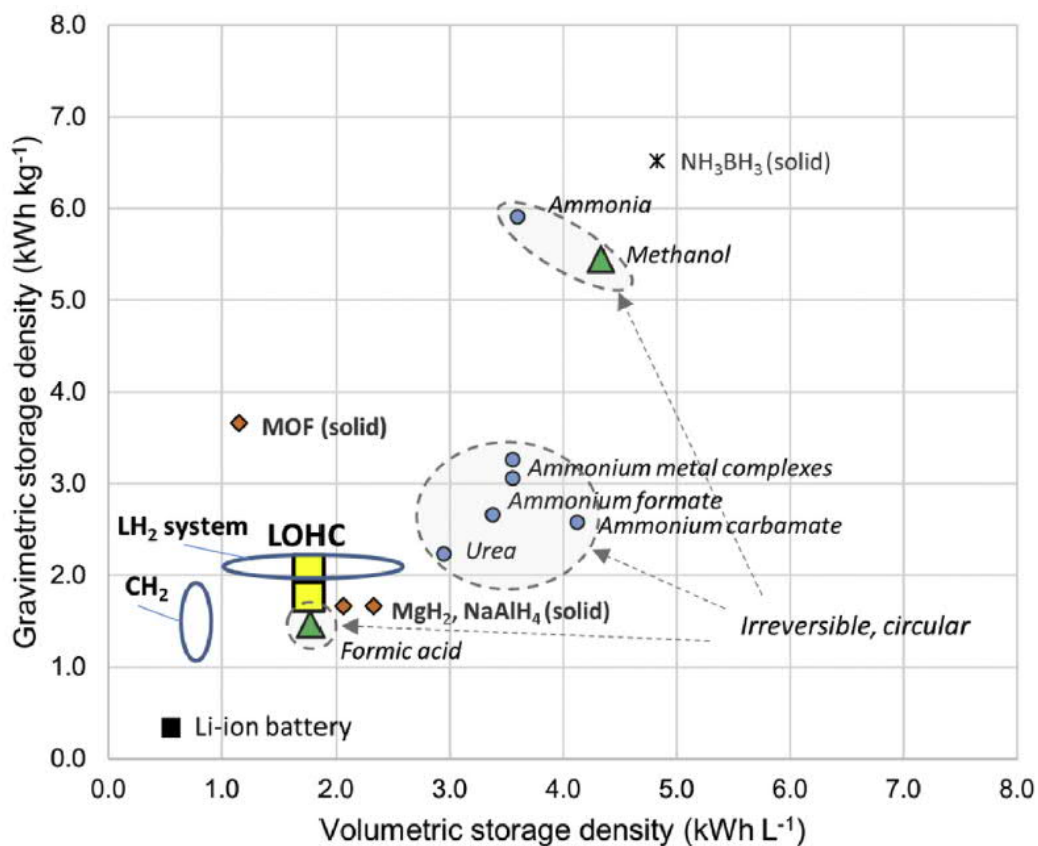

Figure 11. Storage densities for hydrogen storage candidates. (Aakko-Saksa *et al.* 2018)



## 4.5 Applications for the LOHC concept

There are various possible applications for the LOHC concept such as

- Long-term energy storage
- Off-grid energy solutions
- Hydrogen distribution & import and export
- Maritime applications
- Mobility sector

Due to safe and easy handling of liquid LOHC coupled with lossless storage, the LOHC concept would be well suited for long-term energy storage.

For the same reasons, the transportation of hydrogen in form of LOHCs would also be advantageous. This could be either inland truck transport or intercontinental hydrogen trade using tankers.

In addition, the LOHC concept could to enable the use of CO<sub>2</sub>-free fuel for maritime and transport sectors.

## 5. Hydrogen in Finland

---

### 5.1 Hydrogen production and utilisation in Finland

#### 5.1.1 Goal and methods

The understating of the Finnish hydrogen market is a prerequisite for screening the most promising applications for the LOHC concept. Thus, all the plants producing hydrogen were first mapped. The following information was collected for the identified H<sub>2</sub> production plants:

- Owner/operator and location of the plant
- Process type and fuel(s) used
- H<sub>2</sub> production capacity (t/h, MW) and annual production (t/a, GWh)
- Process in which the hydrogen is utilised

The capacities and annual production numbers were estimated based on publicly available information, which consisted mostly of environmental permissions. In some cases it was necessary to make certain assumptions regarding e.g. efficiencies and annual operation hours. Thus, the results should not be considered as “official numbers” but best estimates using public sources.

The emphasis was on “on-purpose” production of hydrogen. For by-product hydrogen only those cases, where the hydrogen is not needed at the site or where it is used in low-value applications (e.g. heat), were considered relevant for this study. For example the by-product hydrogen which forms during oil refining but is later used in later refining steps is not included. Similarly, the cases where by-product hydrogen is not easily recoverable were excluded (e.g. too dilute stream).

#### 5.1.2 Results

The estimated total amount of produced hydrogen in Finland today is ~200 000 t/a or ~6700 GWh (LHV) considering the exclusions described in the previous chapter. Nearly 90% of the hydrogen is produced from fossil sources as shown by Figure 12. The share of steam reforming is 86% and partial oxidation represents an additional 2%. Less than 1% is produced by water electrolysis while around one-tenth is formed as a by-product in chlorine/chlorate electrolysis.

The vast majority (82%) of hydrogen is used in oil refining. Chemical industry (mainly hydrogen peroxide, H<sub>2</sub>O<sub>2</sub> and hydrochloric acid, HCl) and heat & electricity are the second largest sectors. The amount of hydrogen vented into atmosphere from the chlorine/chlorate electrolysis plants represents around 2% of the total utilisation.

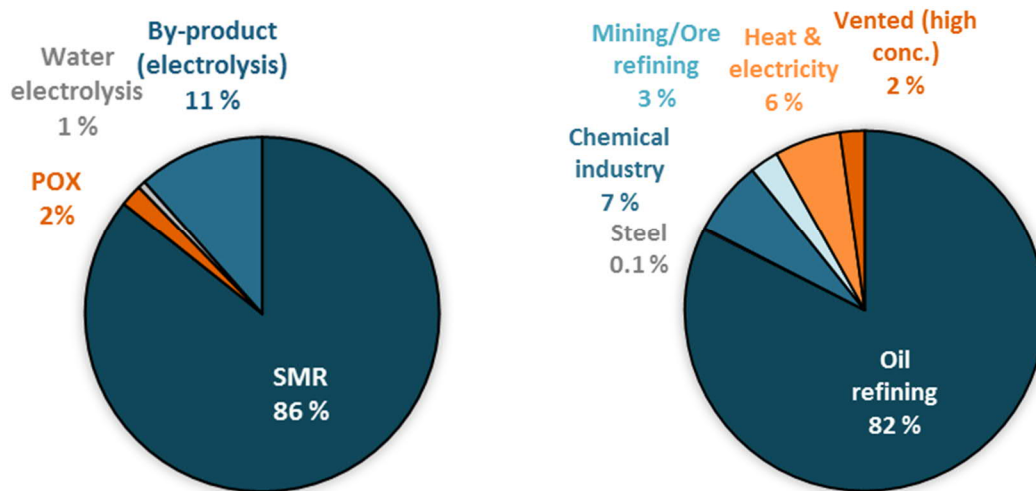

Figure 12. Left: Production of hydrogen by process and Right: Use of hydrogen by sector.<sup>2</sup>

Table 2 lists the identified hydrogen producers and their geographic distribution is illustrated in Figure 13. Results show that:

- There are only a dozen on-purpose hydrogen production plants. In addition four chlor-alkali/chlorate plants are producing hydrogen as a by-product.
- Around 75% of hydrogen is produced in Kilpilahti refinery corresponding to a ~600 MW of hydrogen output (LHV basis).
- For other industry sectors, typical reformer size is ~20 MW H<sub>2</sub> (LHV) (four sites). In addition there are two small-scale reformers 3–6 MW H<sub>2</sub>
- The two water electrolyzers have outputs of 5.5 and 0.4 MW H<sub>2</sub>.
- Chlor-alkali/chlorate electrolyzers have hydrogen outputs of 5–50 MW but a large portion is utilised as heat/steam or as a chemical feedstock

<sup>2</sup> Note: by-product hydrogen formed and subsequently used in different steps of oil refining is not included. Also the minor amounts of by-product H<sub>2</sub> which is not easily recoverable has been excluded.

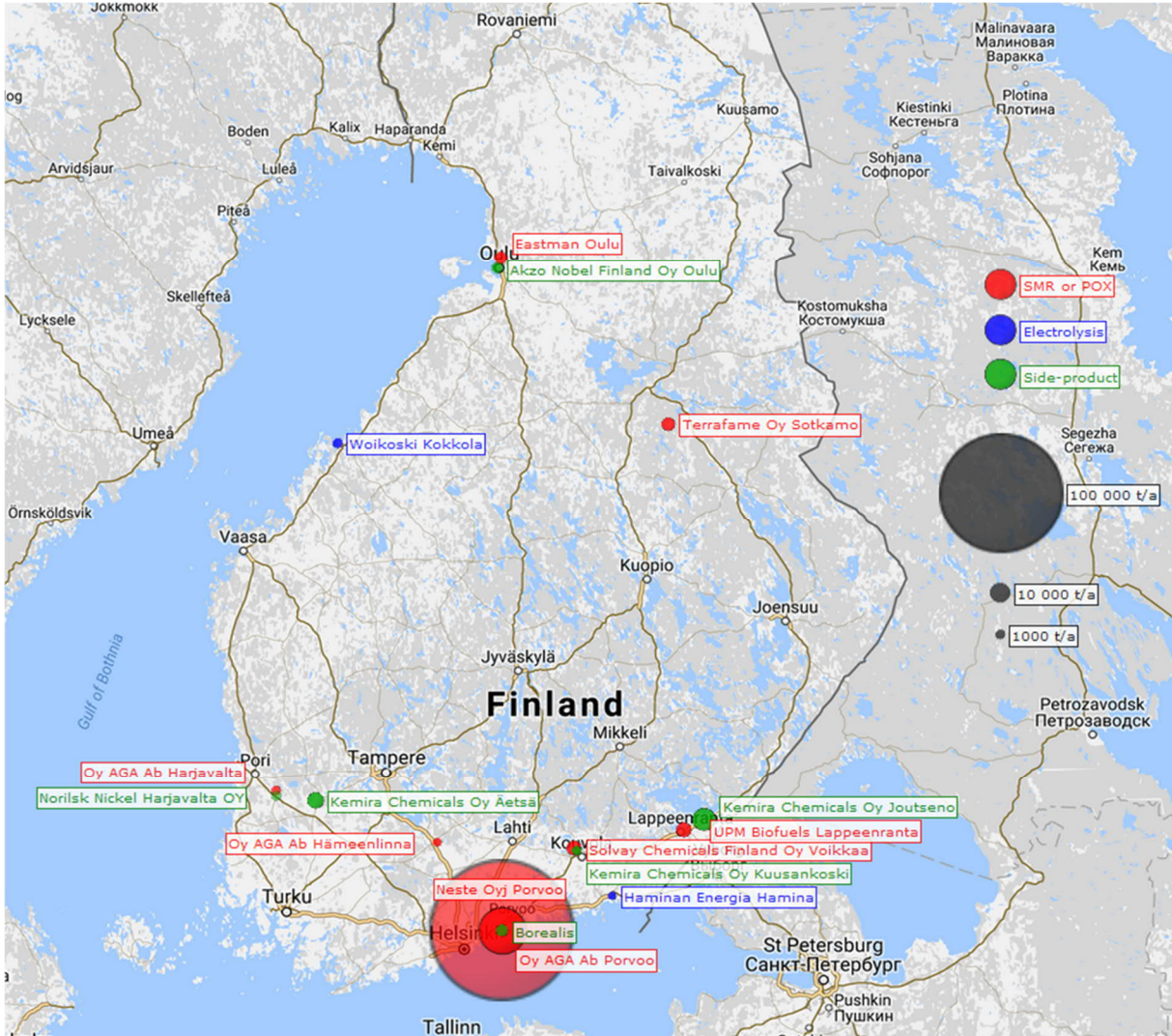

Figure 13. Hydrogen production in Finland.<sup>3</sup>

<sup>3</sup> Note: by-product hydrogen formed and subsequently used in different steps of oil refining is not included due to lack of data. Also the minor amounts of dilute by-product H<sub>2</sub> which is not easily recoverable has been excluded.

Table 2. Production of hydrogen in Finland (SR=Steam reforming, POX=partial oxidation)

Company	Plant/site	Hydrogen output		Annual hydrogen production		Hydrogen production process	Use of hydrogen	Source
		t/h	MW <sub>H<sub>2</sub></sub>	t/a	GWh/a			
Neste Oyj	Kilpilahti oil refinery	13.8	460	118680	3956	SR (natural gas, refinery gas)	Oil refining (hydrocracking, hydrotreating.)	1)
Oy AGA Ab	Kilpilahti oil refinery	4	133	34400	1147	SR (natural gas)	Oil refining (hydrocracking, hydrotreating.)	2)
Terrafame Oy	Sotkamo nickel mine	0.7	22	3840	128	SR (propane)	Production of H <sub>2</sub> S which is used for precipitation of metals as sulphides	3)
Solvay Chemicals Finland	Voikkaa, H <sub>2</sub> O <sub>2</sub> plant	0.7	23	5950	198	SR (natural gas)	Hydrogen peroxide production	4)
UPM Biofuels	Lappeenranta Biodiesel plant	0.7	23	5950	198	SR (natural gas)	Hydrogen treatment of tall oil to produce liquid biofuels	5)
Eastman Chemical Company	Oulu, Formic acid plant (+Kemira H <sub>2</sub> O <sub>2</sub> plant)	0.5	17	4000	133	POX (heavy fuel oil)	"By-product H <sub>2</sub> " from partial oxidation of heavy fuel oil is delivered to Kemira Chemicals for production of hydrogen peroxide while CO is used to synthesize formic acid by Eastman	6)
Oy AGA Ab	Harjavalta Industrial park	0.17	5.7	1197	40	SR (naphtha)	-	7)
Oy AGA Ab	Hämeenlinna, SSAB	0.09	3	225	7.5	SR (natural gas)	Prevention of the oxidation of the steel products at high temperatures	8)
Woikoski	Kokkola, Industrial park	0.17	5.5	1320	44.0	Electrolysis	Freeport Cobalt: reduction of cobalt	9)
Haminan Energia	Hamina	0.01	0.4	100	3.3	Electrolysis	Hydrogen treatment of used oils by STR Tecoil Oy	10)
By-product hydrogen (concentrated sources)								
Kemira Chemicals	Äetsä NaClO <sub>3</sub> plant	0.81	27	7000	233	By-product (chlorate electrolysis)	Fuel in CHP boiler and as raw material in fine chemical production	11)
Kemira Chemicals	Kuusankoski integrated ClO <sub>2</sub> plant	0.16	5	948	31.6	By-product (chlorate electrolysis)	Production of hydrochloric acid (HCl)	12)
Kemira Chemicals	Joutseno, NaOCl <sub>3</sub> +NaOH plants	1.49	50	10000 +2800	427	By-product (chlorate +chlor-alkali)	Fuel in boiler, HCl production in NaOH plant & Woikoski merchant H <sub>2</sub> .	13)
Akzo Nobel Finland	Oulu, integrated ClO <sub>2</sub> plant	0.33	11	2222	74	By-product (chlorate electrolysis)	Fuel in Stora Enso's lime kiln and HCl production	14)

- 1) Neste Oil Kilpilahti Environmental permission, LSY2004Y120
- 2) AGA Kilpilahti Environmental permission, ESAVI/3857/2015
- 3) Talvivaara Environmental impact assessment (Feb 24th 2012) & the annual consumption estimated using nickel production statistics from 2017
- 4) Solvay Chemicals Finland Environmental permission ESAVI/9201/2014
- 5) UPM Environmental permission ESAVI/167/04.08/2011 considering that the realized capacity of the plant is 100 000 t/a.
- 6) Kemira Chemicals Oulu, Environmental permission Dnro PPO-2005-Y1-111 & own assumptions
- 7) AGA Harjavalta Environmental permission 2014, ESAVI/137/04.08/2011
- 8) AGA Hämeenlinna Environmental permission ESAVI/11845/2014. Appendices 4 & 6010a from the application.
- 9) Known electrolyser capacity (9 MWe) & own estimations regarding efficiency (61% LHV) and full load hours (8000 h/a)
- 10) STR Tecoil Oy (at the time L&T Recoil Oy) Environmental permission KAS-2007-Y-155-111
- 11) Kemira Chemicals Sastamala Environmental permission LSSAVI/138/04.08/2012
- 12) Kemira Chemicals (at the time Finnish Chemicals) Kuusankoski, Environmental permission, KAS-2002-Y265-111
- 13) Kemira Chemicals Oy Joutseno Environmental permission, ESAVI/11436/2016
- 14) Akzo Nobel Finland Oy Oulu Environmental permission, PSAVI/127/04.08/2013, hydrogen production capacity was estimated using the capacity of chlorate process and the specific hydrogen production of Äetsä plant

In future, there could be new large-scale utilisers for hydrogen. SSAB has announced their target of decarbonizing their steel production and launched a large research project (“HYBRIT”) together with Vattenfall and LKAB. The aim is to replace the conventional blast furnace based process with a hydrogen-based direct reduction process. In this process, iron ore is first reduced to a so-called sponge iron using hydrogen, which produces only water as a by-product (Figure 14). The sponge iron is then upgraded into steel in an electric arc furnace (Figure 15).



Figure 14. Hydrogen based direct reduction of iron ore. (HYBRIT 2018)

According to their pre-feasibility study (HYBRIT 2018), the process would require 2633 kWh/t crude steel of electricity for producing electrolytic hydrogen. Assuming an electrolyser efficiency of 67% (LHV) this would mean that Raahe mill (2.8 Mt/a crude steel) would require roughly 130 000–150 000 t/a (4250–5000 GWh/a) of hydrogen depending on the share of scrap steel in the raw material input. The hydrogen demand would be comparable to Kilpilahti refinery and would increase the total demand of hydrogen in Finland by 65–75%. However, the commercial HYBRIT process is still quite far away. For the Raahe mill, the plan is to replace the current blast furnaces in stages during 2030’s so that the whole process would be decarbonized in the beginning of 2040.

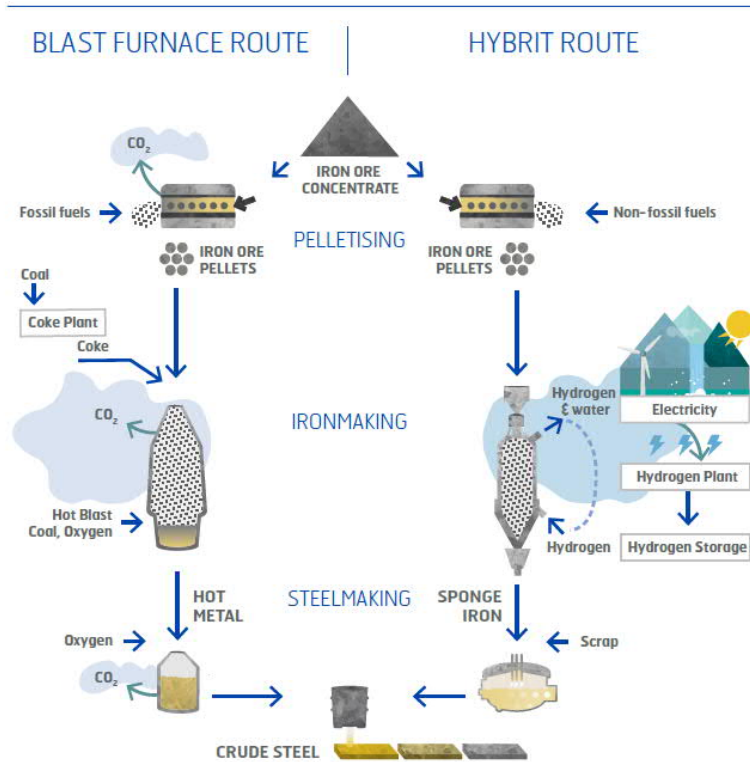

Figure 15. Comparison of the current blast furnace based steel making process and the hydrogen based HYBRIT process. (HYBRIT 2018)

## 5.2 Hydrogen production costs in Finland

To better understand the hydrogen markets and thus the potential role of LOHC, the hydrogen production costs for the main technologies were evaluated. The process performance and cost data was collected from literature while the market parameters (e.g. electricity and fuel prices) correspond to situation in Finland in 2018. The plants were assumed to be “greenfield” plants and they were assumed to supply hydrogen to industrial processes with high capacity factors and constant hydrogen demand.

The technologies considered were:

- Steam reforming
  - Large-scale steam methane reforming (300 MW H<sub>2</sub>) with and without CCS
  - Small-medium scale reforming (20 MW H<sub>2</sub>) with methane or propane
- Water electrolysis (20 MW H<sub>2</sub>, alkaline)
- Biomass gasification (20 MW H<sub>2</sub>, first-of-kind (FOAK) plant)

It should be noted that the technologies are in different stages of development. Steam methane reforming is a widely adopted, fully mature technology while there are no commercial biomass gasification based hydrogen plants operating today. For biomass gasification, indirect fluidised bed steam gasification using forest chips or residues as fuel was considered and the costs were evaluated for a first-of-kind (FOAK) plant Alkaline water electrolysis is a mature technology but it has a marginal role in total hydrogen production today as it has not been cost competitive.

Process flowsheets can be found from Appendix A and the main assumptions are listed in Table 3 and Table 4. No value was given for by-product heat or oxygen (electrolysis case) as they are highly case-dependent. However, for large-scale SMR, the surplus heat was assumed to be used for generating high pressure steam for electricity production.

Table 3. Performance and cost data for the main hydrogen production technologies

Property	Large-scale SMR 1)			Medium-scale SMR 2)	Biomass gasification 3)	Electrolysis 4)
	Without CCS	CO <sub>2</sub> capture from syngas	CO <sub>2</sub> capture from flue gas			
<b>CO<sub>2</sub> capture rate</b>		54%	90%			
<b>Efficiency, % (LHV) Hydrogen<sub>out</sub>/fuel<sub>in</sub></b>	76%	74%	69%	65%	60%	65%
<b>Capacity, MW<sub>H<sub>2</sub>,LHV</sub></b>	300	300	300	20	20	20
<b>CAPEX, M€</b>	223	264	398	28	115	28
<b>Specific CAPEX, k€/MW<sub>H<sub>2</sub>,LHV</sub></b>	743	880	1328	1380	5750	1420
<b>Other OPEX (excl. fuel, electricity, CO<sub>2</sub>) % of CAPEX</b>	3.5%	3.5%	3.0%	4%	3%	5%

- 1) IEAGHG (2017). Techno-Economic Evaluation of SMR Based Standalone (Merchant) Hydrogen Plant with CCS
- 2) Estimated by down-scaling from the large-scale SMR
- 3) VTT in-house modelling and cost estimation for a first-of-a-kind (FOAK) plant
- 4) VTT estimation (CAPEX corresponds to 1000 €/kWe @ 9 MWe and 0.9 scale factor)



Table 4. Market and operation environment

Property	Value	Reasoning/comments
<b>Full load hours</b>	8500 h/a	Hydrogen is used in an industrial process with a high capacity factor
<b>Economic lifetime</b>		
SMR & gasification	25 years	
Electrolysis	20 years	Stack replacement included in O&M costs
<b>WACC</b>	8%	
<b>Fuel prices</b>		
Natural gas	30 €/MWh	
Propane	37.5 €/MWh	Current (2018) prices
Biomass (wood chips/residues)	20 €/MWh	
<b>Fuel taxes (excise tax) for heat production</b>		Excise tax has to be paid for the part of the fossil feedstock used as a fuel (=heat source) in SMR plants. However, if they are supplying hydrogen to oil refining, then also the fuel for heating is tax-exempt.
Natural gas	19.9 €/MWh <sub>heat</sub>	Tax for 2018.
Propane	22.3 €/MWh <sub>heat</sub>	Tax for 2018.
<b>Average electricity spot price</b>	40 €/MWh	Typical value for recent years
<b>Electricity transmission &amp; net tax (electrolysis option)</b>	10 €/MWh	Tax return for energy intensive users 85% which significantly decreases electricity tax
<b>Emission allowance (EU ETS)</b>	20 €/t <sub>CO2</sub>	Current price level (2018)  NOTE: SMR/POX-based hydrogen production falls under the EU ETS only when the capacity exceeds 25 t <sub>H2</sub> /day = 34.7 MW <sub>H2</sub> based on lower heating value.
<b>CO<sub>2</sub> transport and storage cost</b>	40 €/t <sub>CO2</sub>	Large SMR plant at the coast, delivery by ship to geological storage (e.g. Sleipner, Norway)

The production costs range from ~60 €/MWh (~2 €/kg) to ~120 €/MWh (~4 €/kg) as shown by figures 16 and 17. The lowest cost corresponds to large-scale SMR without CCS while biomass gasification leads to highest costs. The costs have been divided into fixed and variable costs. Variable production costs indicate a maximum that existing hydrogen producers could pay for external hydrogen while the total production costs would present a maximum in a situation where no investments for the hydrogen production units would have yet been made.

Due to assumed high full load hours, variable costs dominate over fixed costs in all the other cases except biomass gasification. Due to the capital intensiveness (especially for a first-of-a-kind plant) and relatively low-cost feedstock, fixed costs make up ~60% of the production cost via biomass gasification. However, there is a lot of potential to achieve lower costs. For example, significant reduction of CAPEX could be expected if the technology would be widely adopted and if higher capacity units would be built. The chosen capacity (20 MW H<sub>2</sub>) is at the lower limit of feasibility for biomass gasification. In addition, utilisation of by-product heat could lower the hydrogen production costs.

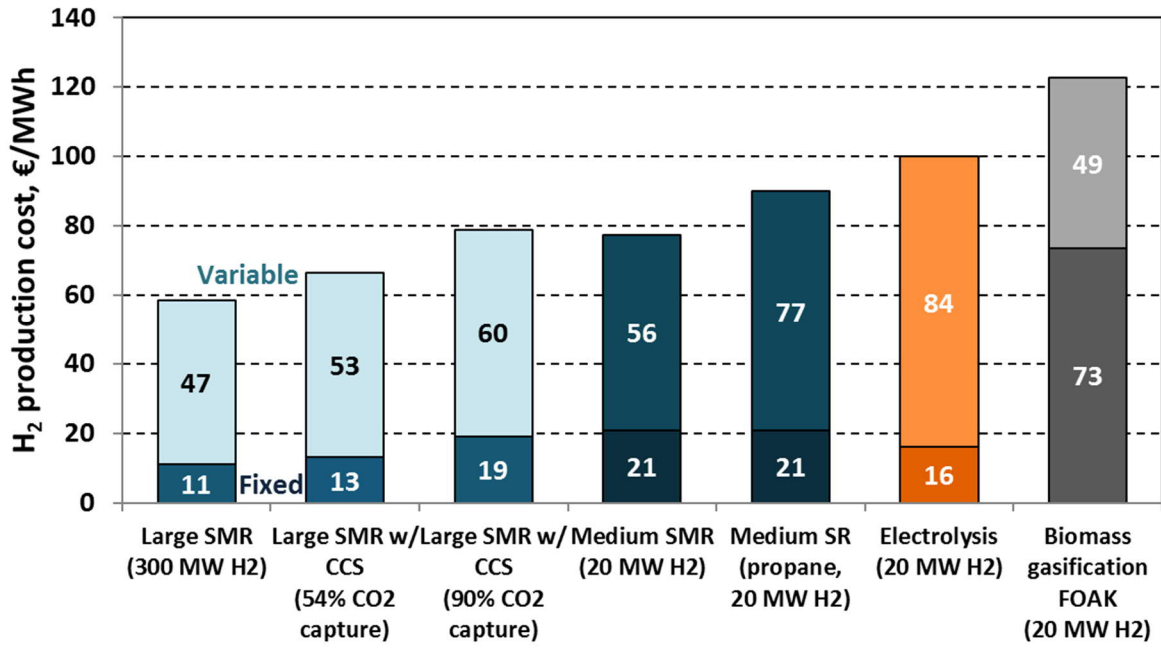

Figure 16. Hydrogen production costs in €/MWh (LHV) in Finland today (greenfield plants).

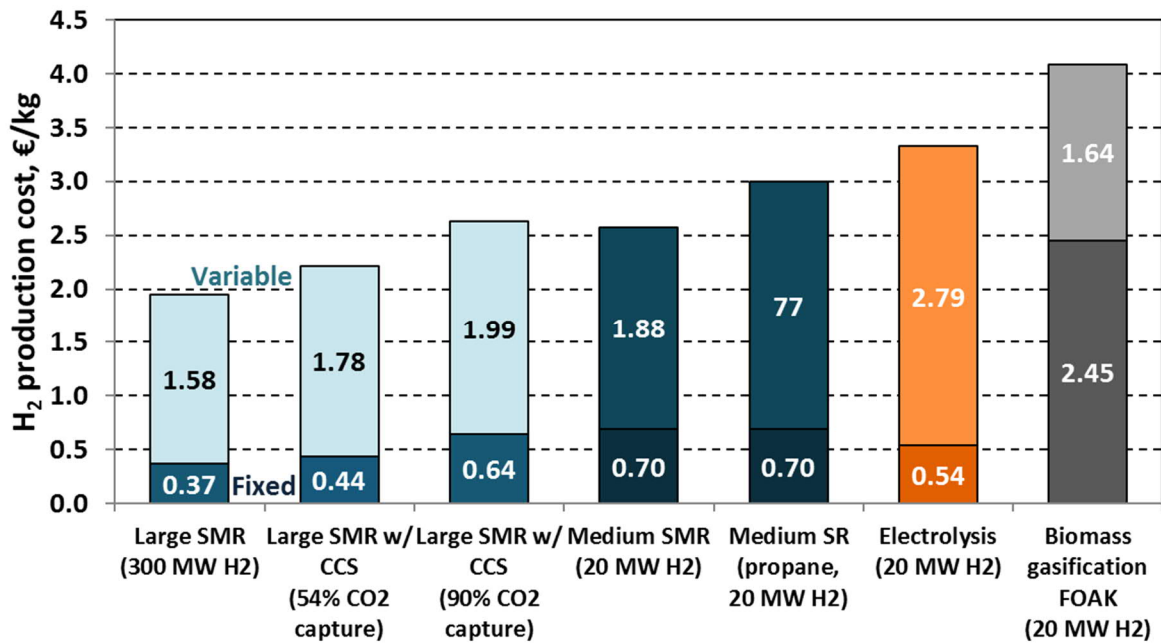

Figure 17. Hydrogen production costs in €/kg in Finland today (greenfield plants).

### 5.3 Overall assessment of the most promising applications for the LOHC concept in Finland

The most favourable end-use for LOHC-based hydrogen would seem to be the applications in which hydrogen is used as a reactant, especially in the near-term. As opposed to non-reversible hydrogen carriers such as methane or ammonia, dehydrogenation of LOHCs results in a pure hydrogen stream (after a simple condensation step) while for the others, H<sub>2</sub> would have to be separated from CO<sub>2</sub> (in case of hydrocarbons) or N<sub>2</sub> (in case of ammonia) streams. Thus, one process step could be eliminated.

The solutions where hydrogen is converted back to electricity do not seem to be attractive in the near-term due to low round trip efficiencies and the lack of variation in Nordpool electricity prices. In future, the demand for large-scale long-term energy storages will arise due to increased shares of intermittent solar and wind power. This demand can first arise in smaller off-grid solutions (e.g. islands) rather than in country or continent level. There could be similar storage needs for large-scale industrial hydrogen consumers also. For example if steel industry would adopt hydrogen-based direct reduced iron process or if oil refineries would replace steam methane reforming with water electrolysis, LOHC concept could enable storing of hydrogen which would make operation of the electrolyzers more flexible. These could open other interesting options for the LOHC concept. For these purposes the “One Reactor concept” (Jorschick *et al.* 2017), in which dehydrogenation and hydrogenation would be carried out in a single reactor, would be particularly interesting.

The most suitable capacity window for the LOHC concept will depend on the hydrogen sourcing. For users currently sourcing their hydrogen as compressed gas, the bigger the demand the better it is for competitiveness of the LOHC concept as compressed gas delivery does not scale up well. Furthermore, the complexity of dehydrogenation reactor means that LOHCs are not the solution for the smallest users. However, there could be an upper limit after which it is more feasible to produce hydrogen on-site. As electrolyzers are modular units, they do not offer major economies of scale after 2 MW<sub>e</sub> and basically none after 10 MW<sub>e</sub> (Figure 18). This means for example that centralised production of hydrogen via electrolysis and distribution via LOHC is likely not feasible in most cases. In Finland there is currently only one plant for which significant amounts of hydrogen (megawatt scale) is delivered as compressed gas – the Danisco Sweeteners’ Kotka plant.

Of the plants currently producing hydrogen via steam reforming of fossil fuels, the ones with the smallest hydrogen production capacities (Table 2) are likely the most potential users for LOHC hydrogen. The smaller steam reformers usually have quite significantly higher specific CAPEX, lower efficiencies and they might use also more expensive propane instead of natural gas leading to higher cost of hydrogen (Figure 16). In some cases, the non-constant demand of hydrogen requires operation on partial load which further decreases the efficiency. Drawback is that reformers whose capacity is below 25 t/day (34.7 MW<sub>H<sub>2</sub>,LHV</sub>) do not currently fall under the EU Emission Trading Scheme (EU ETS). Thus, an increase in emission allowance prices would not incentivize the adaptation of CO<sub>2</sub>-neutral options.

In future, LOHC concept could also find uses in maritime or transportation sector when fuel cell vehicles become more common. This could mean the distribution of LOHC to filling stations where it could either first be dehydrogenated and filled in gaseous form or dehydrogenation could possibly be even carried out on-board the vehicles. LOHC could also enable large-scale import of renewable hydrogen from locations with favourable conditions for renewable electricity.

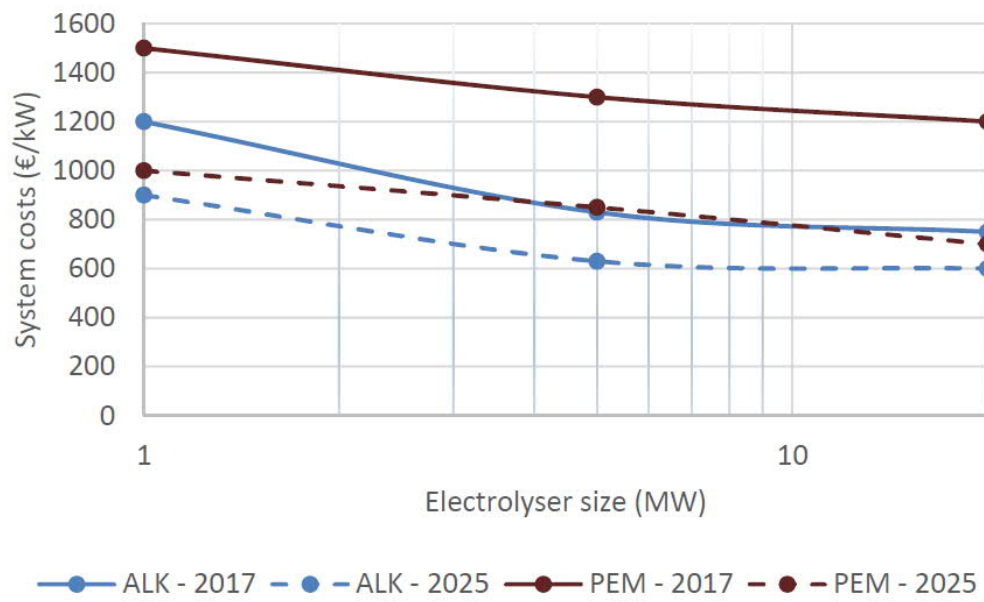

Figure 18. Dependence of electrolyser system costs (€/kWe) on electrolyser capacity (MWe). (FCHJU 2017)

## 6. Case studies on the feasibility of the LOHC concept

---

### 6.1 Introduction

Based on the analysis of the characteristics of LOHC concept and the Finnish hydrogen markets, the following cases were selected for the case studies:

**Case 1:** Delivery of by-product hydrogen from chlorate electrolysis to light industry

**Case 2:** Import of CO<sub>2</sub>-neutral hydrogen to Finland

Finland has several chlor-alkali and chlorate plants from which significant amount of by-product hydrogen is currently vented or used in relatively low-value applications due to lack of cost-effective transport options. At the same time, hydrogen is produced using fossil feedstocks elsewhere. The possible improvement in logistics via LOHC concept could then enable the substitution of fossil based hydrogen with the by-product hydrogen. With LOHC concept hydrogen could possibly be transported to customers located further away and/or having higher hydrogen demands than that can reasonably be met with compressed gas delivery. In addition, there would also be heat integration benefits in chlor-alkali/chlorate plants. Thus, by-product hydrogen would seem like an attractive first business case for the LOHC concept to enter the markets.

Case 2 looks a bit further in the future and considers the production of hydrogen via water electrolysis at a location having favourable conditions for renewable electricity production and subsequent import to Finland.

### 6.2 Case 1: By-product hydrogen from chlor-alkali and chlorate plants to light industry

#### 6.2.1 Overall case description

In this study competitiveness of the LOHC supply chain in transporting by-product hydrogen to industrial customers is evaluated. Hydrogen is assumed to be sourced from a generic chlor-alkali–chlorate plant and delivered to generic industrial customers. Two different hydrogen demands and three transport distances are considered.

LOHC concept is compared to compressed gas delivery – either in steel bottles or in more advanced glassfibre composite cylinders. Delivery as liquid hydrogen is not considered as it was not seen relevant option for the scale of by-product hydrogen due to the very high cost of liquefaction plant. Delivery costs are compared to on-site production of hydrogen via water electrolysis which sets the limit for the price that could be paid for the hydrogen.

The considered case is illustrated in Figure 19.

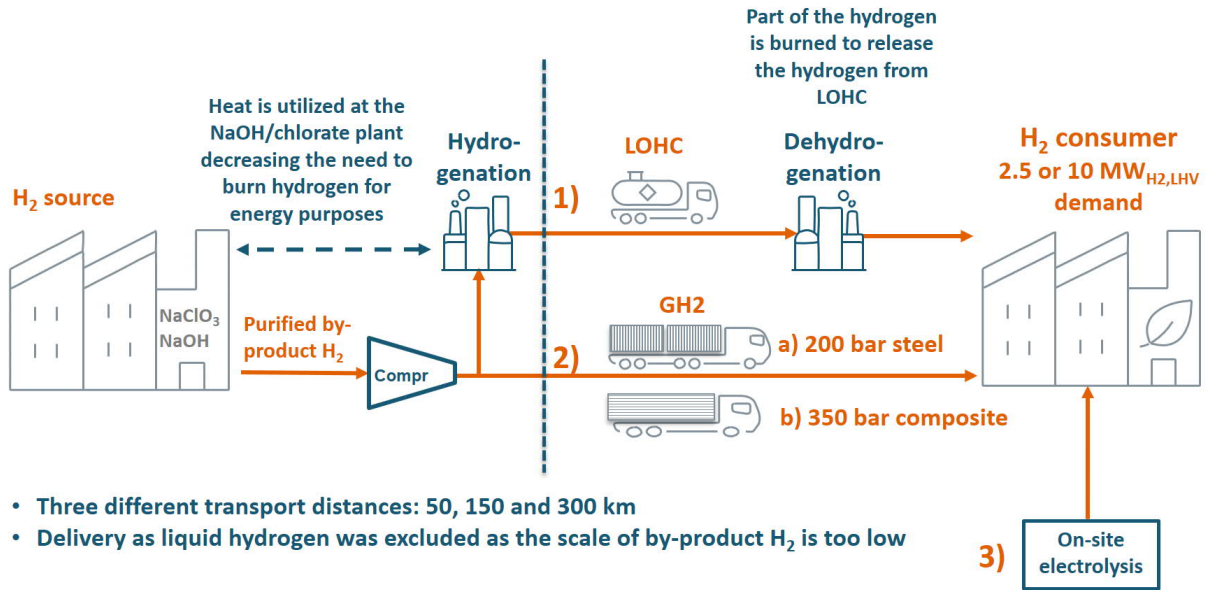

Figure 19. Description of the case 1.

Chlor-alkali–chlorate plant

A typical chlor-alkali–chlorate plant is shown in Figure 20. The main products are sodium chlorate (NaClO<sub>3</sub>), sodium hydroxide (NaOH), hydrogen chloride (HCl) and sodium hypochlorite (NaClO). Significant amounts of hydrogen is also generated as a by-product. The estimated total hydrogen production capacities from Finnish chlorate and chlor-alkali plants ranged from 5–50 MW (Table 2). Depending on the plant some 20–30% of this hydrogen is currently just vented while similar amount is used for quite low-value applications.

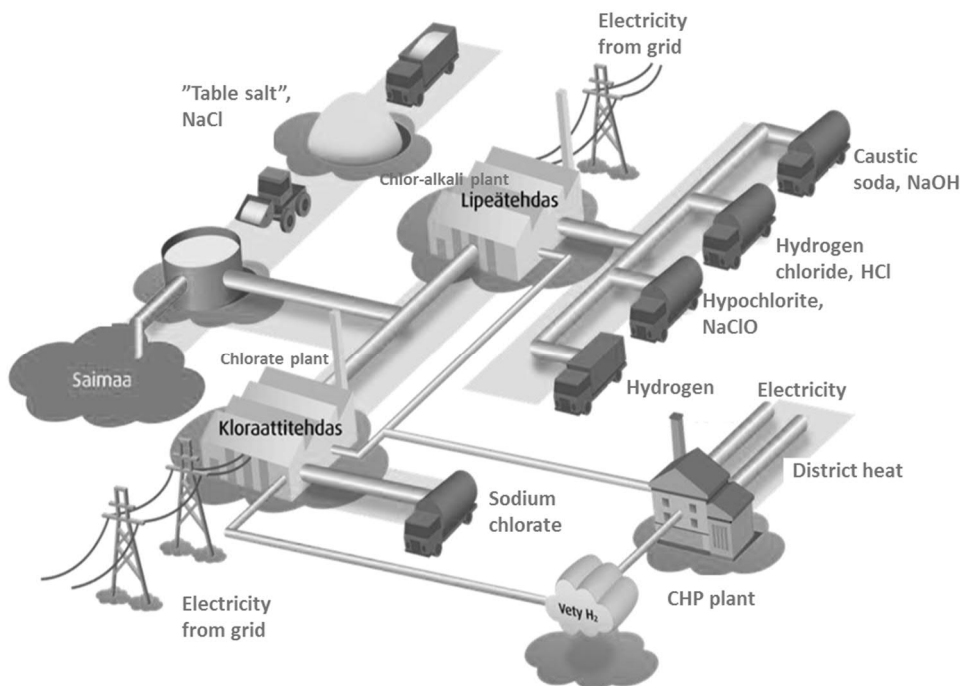

Figure 20. Combined chlor-alkali and chlorate plant. (Adopted from Kärkkäinen 2015)

In the chlor-alkali plant chlorine (Cl<sub>2</sub>) and sodium hydroxide (caustic soda) are produced by electrolysis of an aqueous table salt (NaCl) solution as shown in Figure 21. For each tonne of NaOH, 25 kg of hydrogen is produced as a by-product. Hydrogen is used as an energy source and for production of HCl which also consumes the formed chlorine. In some cases part of it is bottled for merchant uses.



Figure 21. Overall reaction for an ideal chlor-alkali plant.

In the chlorate electrolysis, inputs are the same but due to different construction of the electrolyser, it results in sodium chlorate and hydrogen as products (Figure 22). For each tonne of sodium chlorate 55 kg of hydrogen is formed. Hydrogen is burned to provide the needed process steam and district heat and sometimes also electricity are produced. District heat return water can be first pre-heated using waste heat of chlorate electrolysis and then primed using steam.



Figure 22. Overall reaction for an ideal chlorate plant.

There are differences in the purities of the hydrogen from the two electrolysis types. Hydrogen from the chlor-alkali plant (after traditional purification) is very pure and thus, typically requires only some additional drying and mainly just to be on the safe side also a de-oxo unit. Hydrogen from the chlorate plant on the other hand contains around 2 vol-% of oxygen and trace amounts (< 1 ppm) of chlorine, carbon dioxide after the washing and drying steps. Thus some additional purification would be required, at least a de-oxo unit followed by a dryer. As the main aim of this study is to compare the competitiveness of LOHC concept vs. other supply chains, the additional purification is not considered here. Similar purification would likely be required for each delivery method.

There are various processes requiring heat. In chlor-alkali plant the main steam consumer is the concentration of the NaOH solution by water evaporation. In a chlorate plant steam is used in drying, dissolving and precipitation of chlorate. Majority of the steam is typically used at around 3 bar(a) (130 °C) but the process steam network can be at higher pressure.

In case of LOHC, part of the heat demand could be met by the heat released during hydrogenation (binding of hydrogen to the LOHC). Hydrogenation of DBT is typically carried out at ~150 °C making the reaction heat suitable for generating LP process steam and district heat. Furthermore, it has been shown (Jorschick *et al.* 2017) that it is possible to carry out hydrogenation in temperatures up to 300 °C using the same Pt-Al catalyst as for dehydrogenation. In this case, the direction of the reaction is controlled only by varying pressure (pressure-swing operation) (Figure 23). Figure shows that when the reactor is operated at pressures over 4–8 bar (depending on the temperature), complete hydrogenation can be achieved. Decreasing the pressure to less than 1.5–2.5 bar, makes it possible to release all of the hydrogen. In this case, the process steam generated could also be fed directly to process steam network even if it would be operated at higher pressures. One additional

benefit of this kind of pressure-swing reactor would be that the same reactor could be used to release hydrogen. Thus, it could act as a backup energy source.

For the purposes of this study, dehydrogenation heat is assumed to substitute heat from burning hydrogen without specifying the actual use. The additional hydrogen is considered free for the hydrogen merchant and the steam is free for the hydrogen producer.

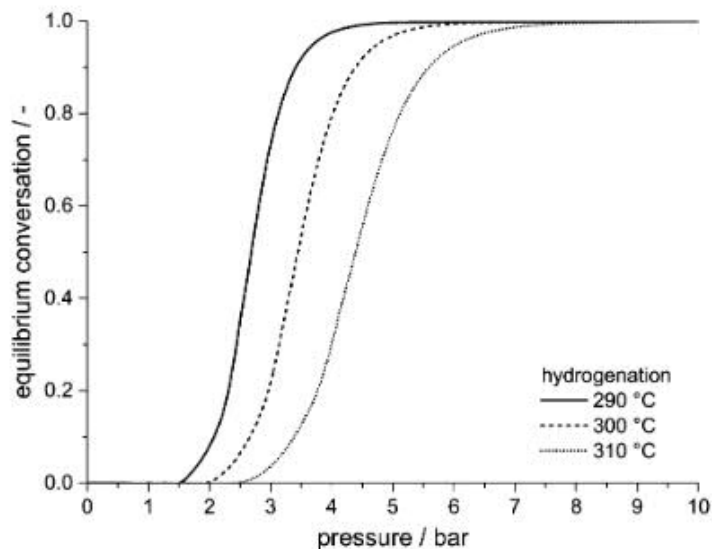

Figure 23. Equilibrium conversion for the hydrogenation of H0-DBT as a function of pressure. (Jorschick et al. 2017)

### Hydrogen consumers

Hydrogen is assumed to be delivered to industrial customers having hydrogen demand of 2.5 or 10 MW (LHV) corresponding to 1800 and 7200 kg/day. Three different transport distances (one-way) are considered: 50, 150 and 300 km.

Hydrogen purity from dehydrogenation after simple condensation is assumed to be sufficient (see chapter 4.2.) without any additional purification. Furthermore, hydrogen pressure from dehydrogenation (<5 bar) is assumed to be sufficient and thus no additional compressors are required in the case of LOHC supply chain.

It is assumed that there is no waste-heat available for the dehydrogenation of the LOHC at the sites. For the LOHC chain two options for releasing the hydrogen could be considered:

- 1) Part of the released hydrogen is burned to provide the required heat. In this case, the total amount of hydrogen delivered would be ~1.45 times the amount delivered by other methods (~30% of hydrogen needs to be burned).
- 2) Hydrogen is released using electrical heating.

As the chlorate plant currently vents hydrogen the first option was seen as the most appropriate choice. Furthermore, utilisation of steam from the hydrogenation reaction will free up the same amount of hydrogen that is required for dehydrogenation (assuming that efficiency of steam generation and heat transfer efficiency of dehydrogenation reactor are equal).

Hydrogen release using fossil sources (e.g. natural gas or propane) was not considered a sustainable option.



6.2.2 Hydrogen conversion / processing

Hydrogenation and dehydrogenation (LOHC)

For the DBT-based LOHC system, reaction enthalpy of 65 kJ/mol<sub>H<sub>2</sub></sub>, storage density of 6.2 wt-% and 100% degree of hydrogenation and dehydrogenation were assumed. Reaction enthalpy corresponds to 27% of lower heating value of hydrogen. Hydrogenation is assumed to take place at 50 bar and dehydrogenation at 5 bar. Heat transfer efficiency of 90% was assumed for providing heat for dehydrogenation. Cost of DBT was assumed to be 4 €/kg. Degradation of DBT was assumed to be 0.1% per cycle.

There is a high degree of uncertainty on the investment costs for dehydrogenation and hydrogenation reactors due to immaturity of technology. Teichmann (Teichmann *et al.* 2012) used values 260 and 40 €/kW<sub>H<sub>2</sub>,LHV</sub> for hydrogenation and dehydrogenation reactors, respectively. Reus (Reus *et al.* 2017) used values of 96 and 72 €/kW<sub>H<sub>2</sub>,LHV</sub> for 300 t/d (417 MW<sub>H<sub>2</sub>,LHV</sub>) units and suggested using a scale factor of 0.6. Eypasch (Eypasch *et al.* 2017) estimated costs for small-scale LOHC systems. For 1 MW<sub>H<sub>2</sub>,LHV</sub> system, specific costs were 252 and 368 €/kW<sub>H<sub>2</sub>,LHV</sub> for hydrogenation and dehydrogenation reactors, respectively.

Thus, there is a wide range in cost estimations and also inconsistency regarding the respective costs of hydrogenation and dehydrogenation reactors. For example Teichmann estimated hydrogenation reactor to be significantly more expensive than dehydrogenation reactor (more than six times!) while Eypasch and Reus estimated the reactor costs to be a lot closer to each other. Eypasch estimated that dehydrogenation reactor is more expensive and Reus had it the other way around.

In order to tackle the uncertainty regarding investment costs, the values from Reus *et al.* 2017 are considered as upper limit values and values from Eypasch *et al.* 2017 represent lower limit values (Figure 24). There is a high uncertainty in the values indicated by Reus as the costs are scaled from hundreds of megawatts to some megawatts range.

Hydrogenation and dehydrogenation reactors were considered to have a depreciation period of 15 years. Fixed O&M costs were assumed to be 4% of the investment costs.

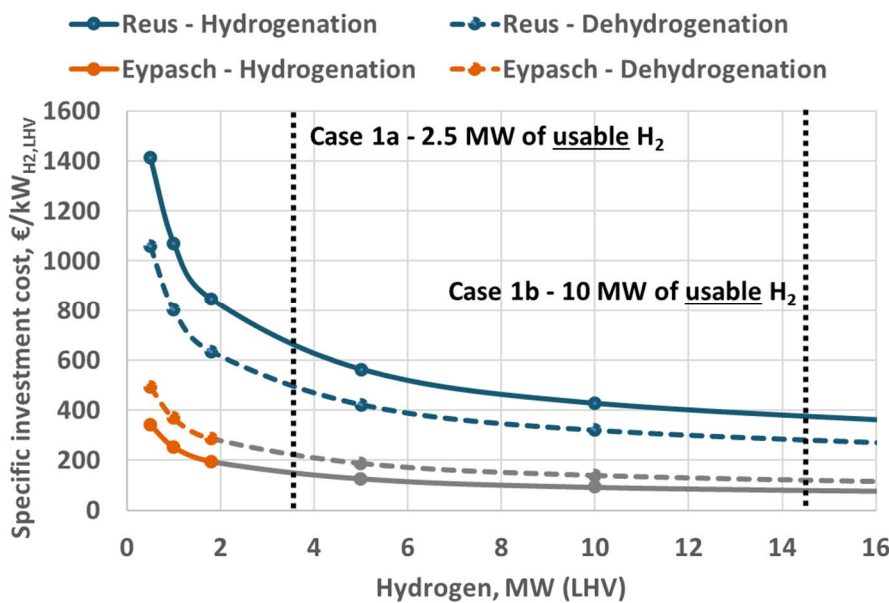

Figure 24. Specific investment costs of hydrogenation and dehydrogenation reactors according to Reus *et al.* 2017 and Eypasch *et al.* 2017. Grey lines represent values that have been extrapolated.

### Compression

As the different supply chains will require different pressure levels, there is a varying need for compression. Hydrogen from the chlorate plant was assumed to be at atmospheric pressure. The specific work ( $W$ , kJ/kg<sub>H2</sub>) for compressors for each case were calculated using equation 1.

$$W = \frac{ZRT_1}{M} \frac{N\gamma}{\gamma-1} \left[ \left( \frac{p_2}{p_1} \right)^{\frac{\gamma-1}{N\gamma}} - 1 \right] / \eta \quad (1)$$

where

$Z$  = compressibility factor

$R$  = universal gas constant (8.3145 J/(mole K))

$T_1$  = suction temperature (313.15 K)

$M$  = molar mass of hydrogen (2.016 g/mole)

$p_1$  = suction pressure

$p_2$  = discharge pressure

$N$  = number of compressor stages

$\eta$  = isentropic efficiency (75%)

$\gamma$  = specific heat ratio ( $c_p/c_v$ ) (1.41)

For filling trailers, logarithmic mean of the maximum ( $p_{max}$ ) and minimum pressures ( $p_{min}$ ) was used as the discharge pressure ( $p_2$ ) (Eq. 2) similarly to the methodology applied by National Renewable Energy Laboratory (NREL 2010). This approach takes into account that the discharge pressure increases towards the maximum value as the tank fills up rather than constantly being at maximum value.

$$p_2 = \frac{p_{max} - p_{min}}{\log\left(\frac{p_{max}}{p_{min}}\right)} \quad (2)$$

Compressors were assumed to have an isentropic efficiency of 75%. Number of compression stages were determined based on maximum compression ratio of 2.5 and intercooling to 40 °C was assumed.

The investment cost of compressors were evaluated using the methodology created in a study by Fuel Cells and Hydrogen Joint Undertaking (FCHJU 2017). The formula (Eq. 3) takes into account the site capacity ( $Q$ , kg/h), total pressure ratio ( $P_{out}/P_{in}$ ) and final pressure ( $P_{out}$ ). The constants used were  $A=100$ ,  $B=300$ ,  $Q_{ref}=50$ ,  $r_{ref}=200/30$ ,  $P_{ref}=200$ ,  $a=b=0.66$  and  $c=d=0.25$ .

$$CAPEX = A \left( \frac{Q}{Q_{ref}} \right)^a + B \left( \frac{Q}{Q_{ref}} \right)^b \left( \frac{P_{out}/P_{in}}{r_{ref}} \right)^c \left( \frac{P_{out}}{P_{ref}} \right)^d \quad (3)$$

SITE	Compression system
Capacity	Capacity Press.ratio Pressure

Hydrogen losses were not considered as they are quite minor and similar for each option. Compressors were considered to be depreciated in 15 years. Fixed O&M costs were assumed to be 4% of the investment costs.

### Other costs

While compressors and hydrogenation/dehydrogenation reactors represent the main equipment cost, additional costs will incur e.g. from piping, buildings and engineering costs. For GH2 cases these are estimated at 500 and 1000 k€ for 2.5 and 10 MW cases respectively. For LOHC cases slightly higher values of 750 and 1500 k€ were used due to higher hydrogen flows and added complexity caused by the utilisation of steam.

#### 6.2.3 Transport / trucking

The transport units consist of a truck and a trailer. The truck is assumed to be identical for each delivery method but three different trailers are considered:

- 1) a trailer carrying two 200 bar steel bottle containers
- 2) a trailer carrying a 350 bar glassfibre composite cylinder container
- 3) a LOHC tanker trailer.

Truck delivery of hydrogen has been comparably expensive which has limited the utilisation of by-product hydrogen. In Finland, hydrogen is nowadays delivered in 200 bar steel gas bottle containers, which will act as the reference case. One truck can deliver two containers each weighing around 20 t. Investment cost for the containers and the rolling platform is 530 000 €.

However, more efficient options also for compressed gas delivery are now available. For example UMOE Advanced Composites AS (<https://www.uac.no/>) offers gas containerized (ISO20, ISO40) cylinder bundles in a pressure range 200–350 bar and with hydrogen capacities up to 930 kg. Due to the light composite structure prices are competitive, 400–500 €/kg of stored hydrogen for the pressure vessels. UAC uses type IV pressure vessels with plastic liner, stainless steel end bosses and composite structure made of high-strength glass fibre and epoxy resin. A 350 bar ISO40 (ADR 22) container is considered in this study as it leads to a similar total mass as the steel container option. It has a net capacity of ~900 kg and the price for the container + trailer is 420 000 €.

A tanker trailer with the capacity of 36 000 liters can carry around 2000 kg of hydrogen in the form of LOHC (H18-DBT). In point-to-point deliveries – like the one considered here – the same truck can bring back the depleted LOHC. Based on the cost of a tanker trailer used for transporting liquid fuels, the investment cost for the LOHC tanker trailer is taken as 140 000 €.

The number of required deliveries per day will depend on the hydrogen demand and delivery method. Theoretical maximum number of trips for each truck per day will depend on unloading/loading (drop-off/pickup) times, transport distance and average speed. Deliveries are assumed to take place 24/7 if necessary, which is also the case currently. For gaseous hydrogen delivery chains, it is assumed that the trailer (or container) full of hydrogen is dropped off at the site and the empty one is picked up.

Required number of trucks was calculated using the theoretical maximum number of trips per day and then rounding up to nearest larger integer. After rounding up, the lowest amount of trips per day that meets the hydrogen demand is selected allowing also non-integer numbers. For example 0.5 trips per day could mean delivery every other day.

The number of trailers needed for GH2 delivery options is three times the number of trucks: one is being transported, one is being filled up at the hydrogen source and one is being emptied at the hydrogen consumer. In case of LOHC transport, the trucks will wait while the tanker trailer is first unloaded and then loaded. Two stationary storage tanks for LOHC are required both at the hydrogen producing and hydrogen consuming sites: one for the hydrogen-rich LOHC and one for the hydrogen-lean LOHC. The total amount of LOHC fluid required is

assumed to be 3 times the capacity of the tankers. For GH2 delivery there are no other storages in addition to trailers themselves.

The truck and trailer related assumptions are listed in Table 5.

Table 5. Truck and trailer related assumptions

	Truck	LOHC tanker trailer (36 000l)	GH2 trailer (2x200 bar steel bottle ISO20 containers)	Advanced GH2 trailer (ISO40 HC 350 bar composite)
<b>Investment cost</b>	180 k€	140 k€[3]	530 k€[3]	420 k€[3]
<b>Depreciation period</b>	1.5M km [1] or 8 years	15 years	15 years	15 years
<b>Fixed O&amp;M</b>	0.1 €/km [1]	4% of CAPEX	2% of CAPEX	2% of CAPEX
<b>Net H<sub>2</sub> payload</b>		2000 kg	400 kg	900 kg [4]
<b>Unloading &amp; loading time (LOHC)</b> <b>Drop-off &amp; pick-up time (GH<sub>2</sub>)</b>		1 h +1 h [4]	1 h +1 h [4]	1h + 1 h [4]
<b>Diesel consumption</b>	45 l / 100 km			
<b>Diesel price (VAT0%)</b>	1.05 €/l			
<b>Avg. speed (excl. unloading &amp; loading)</b>	65–72–77 km/h (50–150–300 km)			
<b>Driver employment cost (incl. indirect costs)</b>	45 k€/a			
<b>Truck availability</b>	80% [2]			

[1] Mezler *et al.* (2018) [2] Yang & Ogden (n.d) [3] Quotations from suppliers (cost of rolling platform for GH2 options was assumed to add 70 k€ to the cost) [4] Teichmann *et al.* (2012) [5] UMÖE Advanced composites

#### 6.2.4 On-site production of hydrogen

The on-site production of hydrogen is assumed to be carried out via water electrolysis. Hydrogen demand even in the lower demand scenario (2.5 MW) is high enough to make this option feasible. A 2x2 MWe alkaline electrolyser with efficiency of 62 % (LHV) is considered. Total investment costs including grid connection and hydrogen buffer storage are estimated at 5 M€. For the 10 MW<sub>H<sub>2</sub></sub> case, investment cost is 15 M€. O&M costs are 5% of CAPEX and they include the stack replacement costs. No value is given for the by-product oxygen or low-temperature heat.

#### 6.2.5 General assumptions

As chlorate and chlor-alkali plants are typically operated throughout the year at maximum capacity, the capacity factor for hydrogen processing/loading was taken as 8500 h/a.

When necessary, investment costs were first scaled according to Eq. 4 and then annualized using a Weighted Average Cost of Capital (WACC) of 8%.

$$Investment\ cost = Reference\ investment\ cost \times \left( \frac{Capacity}{Reference\ capacity} \right)^{Scale\ factor} \quad (4)$$

The price of electricity was taken as 50 €/MWh.

6.2.6 Results

The delivery costs of hydrogen are shown in Figure 25 together with on-site production costs via water electrolysis. It should be borne in mind that the delivery costs represent only the conversion (compression, (de)hydrogenation) and trucking of hydrogen. When comparing these to the on-site production costs, the value for the hydrogen itself and also the additional purification of hydrogen must be taken into account. Thus, the difference in the delivery costs (bars) and on-site production costs (horizontal lines) represent the maximum value of purified by-product hydrogen.

In addition it should be noted that backup equipment was not considered in the study. In reality when it is required to ensure uninterrupted supply of hydrogen, there must be backup compressors, trailers etc. which would slightly increase the delivered cost of hydrogen for every case.

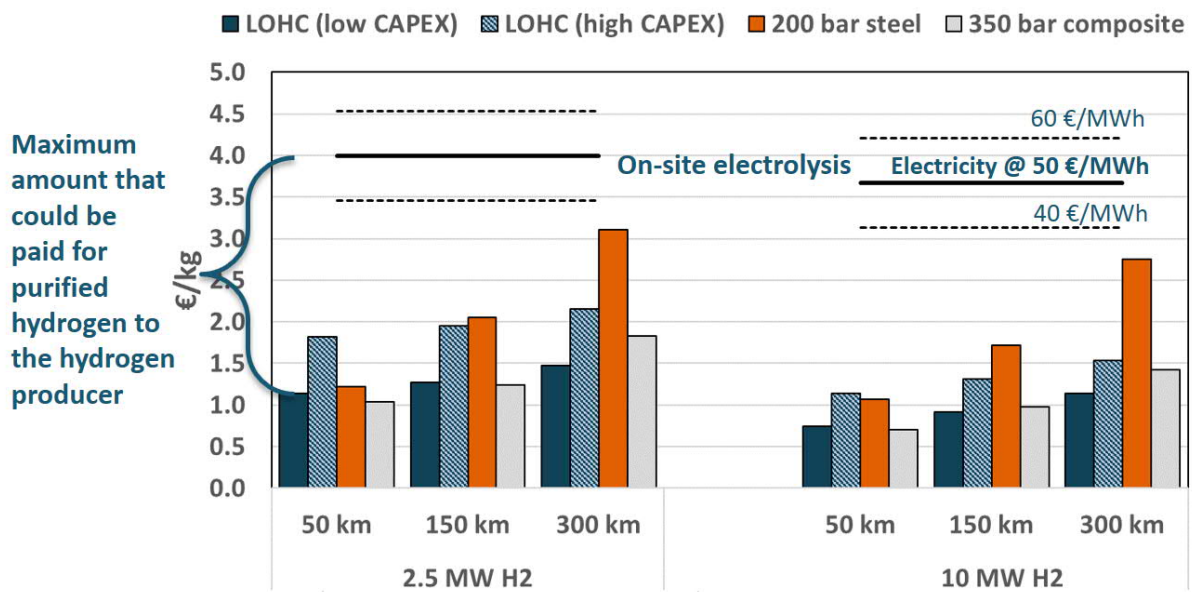

Figure 25. Hydrogen delivery costs (bars) and on-site production cost (lines) in €/kg.

The results show that

- The total delivery costs for 2.5 MW (1800 kg/day) and 10 MW (7200 kg/day) cases ranged from 1.0–3.1 €/kg and 0.7–2.8 €/kg, respectively.
- With low CAPEX estimation for dehydrogenation and dehydrogenation reactors, LOHC and composite GH2 are equally competitive for 50–150 km while 300 km favors LOHC.
- With high CAPEX estimation, composite GH2 is the most feasible in every case.
- LOHC delivery cost do not increase markedly with transport distance.
- Delivery using 200 bar steel bottle containers is not the least cost option in any of the cases and the costs increase steeply with transport distance.
- LOHC and composite GH2 options scale more favorably from 2.5 to 10 MW. Cost reductions range from 23–37% for LOHC, 21–32% for composite cylinders and only 11–17% for steel bottles.
- On-site hydrogen production costs are higher than the delivery costs of by-product hydrogen, which leaves margin to pay for the hydrogen raw material and purification. With the default electricity price of 50 €/MWh, the margins for 2.5 MW and 10 MW

cases were ~2.2–3.0 and ~2.1–2.8 €/kg respectively when the least-cost delivery option is chosen for each transport distance. The production costs of electrolytic hydrogen are highly dependent on the electricity price. An increase of 10 €/MWh in electricity price will increase the cost (and thus o the margin) by ~0.5 €/kg. Default value of 50 €/MWh is likely in the lower end of the electricity price range.

In case the hydrogen consumer would have already invested in an electrolyser, the margins would drop to ~1.2–2.0 and ~1.3–2.0 €/kg due to the fact that by-product hydrogen would then compete against variable costs of electrolysis only. However, in this case by-product hydrogen could allow avoiding the use of electrolyser when the electricity prices are high. Thus, margins could be even higher than in the reference case but the delivered amounts of hydrogen would be lower.

The detailed costs breakdowns for 2.5 MW and 10 MW cases are shown in figures 26 and 27, respectively. For the LOHC chains, the main costs are related to hydrogen processing while for GH2 delivery the costs are governed by trucking costs especially in the case of steel bottle containers and longer transport distances. This explains the differences in the effects of transport distance on the delivery costs between different options. It can also be seen that electricity costs make up only a minor share of total delivery costs and that there is not much difference between different options.

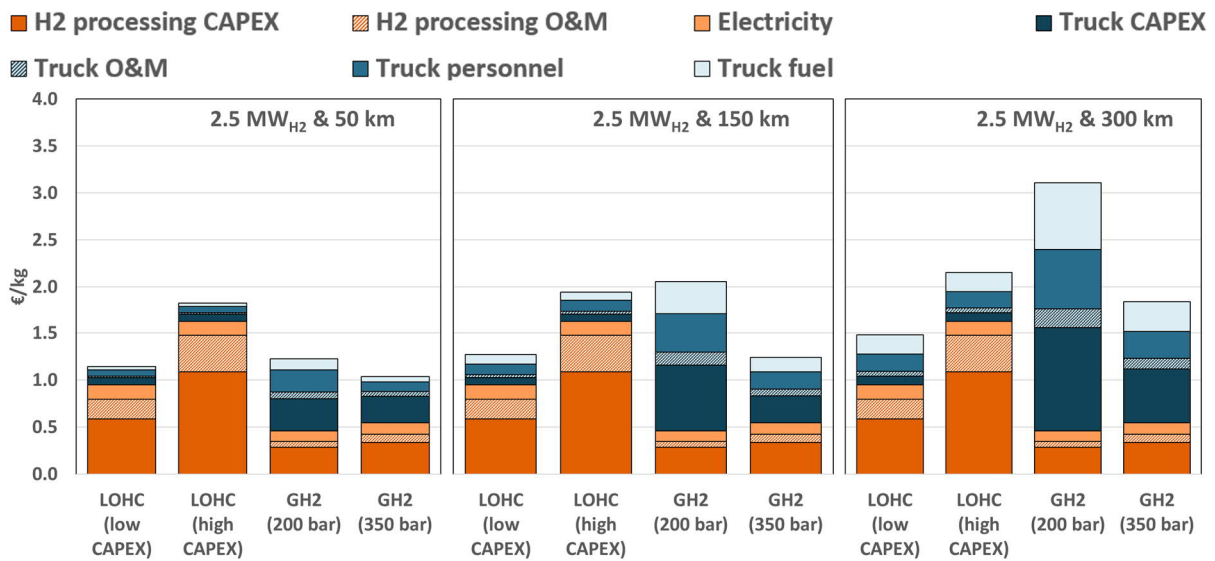

Figure 26. Detailed cost breakdowns for 2.5 MW hydrogen demand cases (50, 150 and 300 km). H<sub>2</sub> processing includes compression, hydrogenation, dehydrogenation and related site costs (piping, buildings, engineering) but not purification.

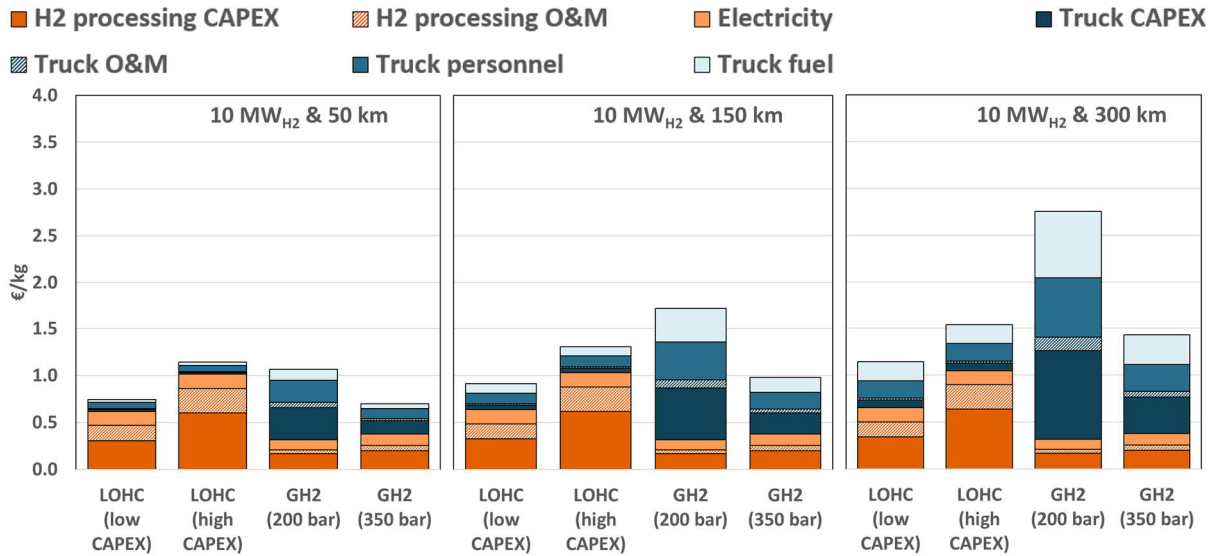

Figure 27. Detailed cost breakdowns for 10 MW hydrogen demand cases (50, 150 and 300 km). H<sub>2</sub> processing includes compression, hydrogenation, dehydrogenation and related site costs (piping, buildings, engineering) but not purification.

Figures 28 and 29 illustrate the required number of trucks and trailers for each case. With the lower hydrogen demand, one LOHC tanker trailer can deliver the needed hydrogen even if the distance is 300 km. Higher hydrogen demand and longest transport distance would require three tanker trailers while delivery in steel bottles would require a massive fleet of 10 trucks and 30 trailers.

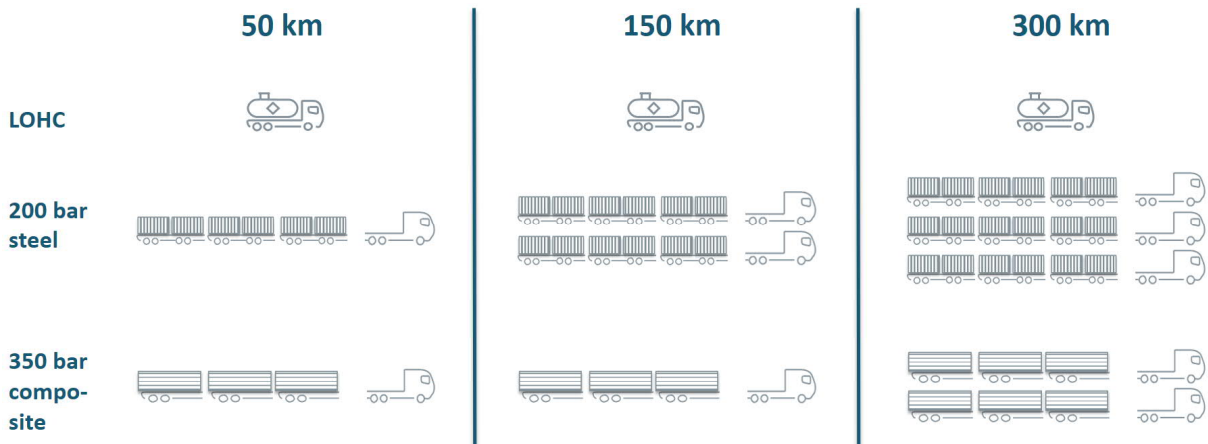

Figure 28. Required number of trucks and trailers in 2.5 MW (1800 kg/day) cases. For LOHC the actual transported amount of hydrogen is ~2600 kg/day as ~30% needs to be burned to release the hydrogen.

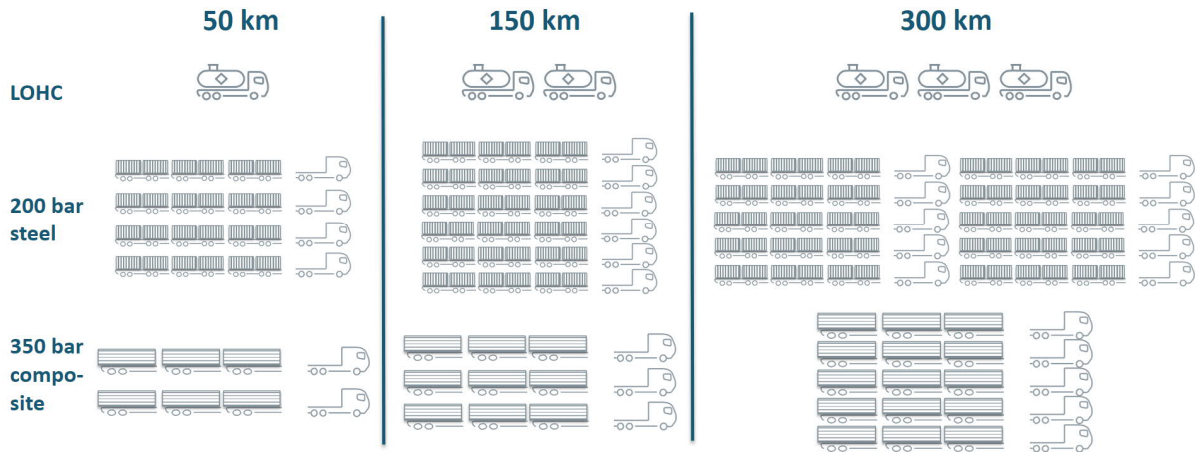

Figure 29. Required number of trucks and trailers in 10 MW (7200 kg/day) cases. For LOHC the actual transported amount of hydrogen is ~10 300 kg/day as ~30% needs to be burned to release the hydrogen.

The generalized results are shown in Figure 30 which depicts the most feasible transport method and the corresponding delivery cost for different hydrogen demands and transport distances. The irregularities are due to requirement that the number of trucks and trailers need to be a natural number (=non-ideal scaling). It should be noted that the model used did not optimize the delivery fleet for each case. For example, the capacities of trailers were fixed.

kg/day	MW	Composite GH2 most feasible											LOHC (low CAPEX) most feasible
		25 km	50 km	75 km	100 km	125 km	150 km	175 km	200 km	225 km	250 km	275 km	300 km
1800	2.5	0.98	1.03	1.09	1.14	1.19	1.24	1.30	1.34	1.37	1.41	1.44	1.48
3600	5	0.72	0.78	0.83	0.97	1.01	1.04	1.08	1.12	1.19	1.23	1.26	1.30
5400	7.5	0.62	0.78	0.83	0.88	0.94	0.98	1.01	1.05	1.08	1.12	1.15	1.18
7200	10	0.65	0.70	0.75	0.84	0.88	0.91	0.95	0.98	1.04	1.07	1.11	1.14
9000	12.5	0.60	0.65	0.76	0.80	0.84	0.89	0.92	0.96	0.99	1.03	1.08	1.11
10800	15	0.56	0.66	0.71	0.77	0.82	0.85	0.89	0.92	0.97	1.01	1.04	1.07
12600	17.5	0.58	0.63	0.71	0.76	0.79	0.83	0.88	0.91	0.94	0.99	1.03	1.06
14400	20	0.55	0.60	0.69	0.74	0.77	0.82	0.85	0.89	0.93	0.97	1.00	1.05
16200	22.5	0.53	0.61	0.67	0.72	0.77	0.80	0.85	0.88	0.91	0.96	0.99	1.02
18000	25	0.51	0.59	0.67	0.72	0.75	0.79	0.83	0.86	0.91	0.94	0.98	1.02
19800	27.5	0.52	0.60	0.65	0.70	0.75	0.78	0.81	0.86	0.89	0.93	0.97	1.01
21600	30	0.51	0.59	0.66	0.69	0.73	0.77	0.81	0.84	0.89	0.92	0.96	0.99

Figure 30. Generalized results for the most feasible transport option and corresponding cost depending on transport distance and hydrogen demand.

### 6.2.7 Sensitivity analysis

The sensitivity of the results with respect to selected parameters were studied by comparing the delivery costs via LOHC (low CAPEX) and composite GH2 when transport distance is 150 km and hydrogen demand 2.5 MW (1800 kg/day) (Figure 31).

The general variables (WACC, electricity price and diesel price) were found to have only a minor effect on the respective competitiveness of the two delivery options:

- Electricity demands and total capital costs were in the same range: the higher hydrogen processing CAPEX for LOHC chain are compensated by lower trucking related CAPEX. Cost of capital, however, affected the absolute delivery costs quite significantly.
- Fuel costs on the other hand represented only a small share of the total costs and thus lower fuel costs for LOHC did not entail marked competitive advantage.



The price of the LOHC compound (dibenzyltoluene, DBT) had only a relatively small effect on the results despite the high sensitivity price range (2–6 €/kg) because hydrogen is not stored for extended periods of time. LOHC degradation on the other hand could have a significant effect due to continuous hydrogenation/dehydrogenation cycles if the actual degradation is significantly higher than assumed here (0–0.2% per cycle). The most important factor is however, the capital costs of the hydrogen conversion reactors for LOHC. There is no reliable information on the costs available due to immaturity of the technology.

	LOHC (low CAPEX)	Composite GH2	Diff. (LOHC-Composite)
5 %	1.16	1.14	0.02 €/kg
WACC 8% (Default)	1.27	1.24	0.03 €/kg
10 %	1.35	1.32	0.03 €/kg
35 €/MWh	1.23	1.20	0.02 €/kg
Electricity 50 €/MWh	1.27	1.24	0.03 €/kg
70 €/MWh	1.33	1.29	0.04 €/kg
0.9 €/l	1.26	1.22	0.04 €/kg
Diesel 1.05 €/l	1.27	1.24	0.03 €/kg
1.2 €/l	1.29	1.26	0.02 €/kg
2 €/kg	1.19	1.24	-0.05 €/kg
DBT price 4 €/kg	1.27	1.24	0.03 €/kg
6 €/kg	1.35	1.24	0.11 €/kg
0% per cycle	1.19	1.24	-0.06 €/kg
LOHC degradation 0.1% per cycle	1.27	1.24	0.03 €/kg
0.2% per cycle	1.36	1.24	0.12 €/kg
80 %	1.21	1.24	-0.03 €/kg
LOHC reactor CAPEX 100%	1.27	1.24	0.03 €/kg
150 %	1.43	1.24	0.19 €/kg
200 %	1.59	1.24	0.35 €/kg

Figure 31. Sensitivity analysis for the 2.5 MW & 150 km case.

The effect of the assumed heat source for dehydrogenation was also studied for the case 2.5 MW & 150 km, low CAPEX. In the reference cases, it was assumed that part of the delivered hydrogen is burned to provide the heat required for releasing hydrogen from the LOHC. When considering external heat sources, it is also required to consider the value of heat released in hydrogenation, which should be roughly the same as the value of hydrogen in most cases. When dehydrogenation was considered to be carried out by burning part of the delivered hydrogen, the value of hydrogenation heat (or hydrogen) was not required for calculating the delivery costs because the hydrogenation heat was assumed to be exchanged with this “additional fuel hydrogen” 1:1.

Figure 32 shows the delivery costs with respect to the cost of dehydrogenation heat and the value of hydrogenation heat. The first column corresponds to a situation where there is no value for the heat released during hydrogenation. This could be the case when the utilisation of heat from hydrogenation would just increase the amount of hydrogen that will be vented. The first row describes a situation where there is free waste-heat (~300–350 °C) at the hydrogen consuming site.

Due to the high enthalpy of hydrogenation/dehydrogenation reaction, it is not surprising that the assumptions on the value or cost of heat can have a marked influence on the hydrogen delivery costs. For example if free waste-heat is available and if the value of by-product heat is 30 €/MWh, the costs could decrease by ~40% compared to the reference case.

Even with equally valued hydrogenation and dehydrogenation heats the delivery costs would be lower than in the reference case (1.27 vs 1.03 €/kg of utilisable H<sub>2</sub>) because less hydrogen needs to be transported when external heat is utilised. In the reference case the total amount of hydrogen delivered as LOHC was ~2600 kg/day while for external heat utilisation 1800 kg/day is sufficient.

No value for by-product heat at the chlorate/chlor-alkali site  
(=utilisation of heat leads to venting more H<sub>2</sub>)

		Value of by-product heat from hydrogenation						Free waste-heat for dehydrogenation
		0 €/MWh	10 €/MWh	20 €/MWh	30 €/MWh	40 €/MWh	50 €/MWh	
Cost of heat for dehydrogenation	0 €/MWh	1,03	0,94	0,85	0,76	0,67	0,58	
	10 €/MWh	1,12	1,03	0,94	0,85	0,76	0,67	
	20 €/MWh	1,21	1,12	1,03	0,94	0,85	0,76	
	30 €/MWh	1,30	1,21	1,12	1,03	0,94	0,85	
	40 €/MWh	1,39	1,30	1,21	1,12	1,03	0,94	
	50 €/MWh	1,48	1,39	1,30	1,21	1,12	1,03	

Figure 32. The effect of using external heat source for dehydrogenation with different heat prices for the case 2.5 MW, 150 km, LOHC low CAPEX.

## 6.2.8 Conclusions and discussion

LOHC seems to be a viable option for transporting by-product hydrogen from chlorate/chlor-alkali plants when transport distances are >100–200 km if the capital costs for the conversion reactors are in the lower-end of the literature estimates. The higher the hydrogen demand and especially longer the transport distance, the better the LOHC chain's economics look compared to delivery as gaseous hydrogen. This is due to the fact that for LOHC concept, the costs are mainly governed by hydrogen processing costs while for gaseous hydrogen delivery, trucking costs are more important. For gaseous hydrogen, composite cylinders were significantly more cost competitive than steel bottle containers and thus they are likely the main alternative for LOHCs in the future.

Capital costs of the LOHC reactors were found to have a marked influence on the delivery costs. As LOHC technology is still in early phases, the capital cost estimations still include significant uncertainties and more accurate estimates should be pursued. The validity of the assumption, that the purity of the released hydrogen is sufficient without any complex purification, should be considered case by case as the purity requirements will vary depending on the end-use.

In the reference cases, release of hydrogen was assumed to be carried out by burning part of the delivered hydrogen. In cases where there would be medium temp waste or low-cost heat (~300–350 °C) available at the hydrogen consuming site, LOHC economics could improve markedly. For example an industrial site where hydrogen is produced by steam methane reforming (SMR) and which would require additional hydrogen production capacity, could be a favourable case for LOHC based hydrogen delivery. If the by-product steam from reforming is not needed or is converted to electricity at low efficiency it could be used for LOHC dehydrogenation instead and the investment to a new hydrogen production unit could be avoided.

One advantage of the LOHC chain, which is not shown by the €/kg figures, is the possibility to have significantly larger hydrogen storages at reasonable costs which could make the delivery chain a lot less hectic compared to GH<sub>2</sub> delivery. With minor over dimensioning of the system, the delivery schedule could be more flexible and it would be possible to prepare for the maintenance and unscheduled breaks in the hydrogen source plant.

In real world cases the delivery costs would be slightly higher for every option as the uninterrupted supply of hydrogen would require investment into backup units and some safety margin.

### 6.3 Case 2 - Import of renewable hydrogen

#### 6.3.1 Case description

In future electricity production must be carbon-neutral. Demand of electricity will increase as the population and the standard of living will continue to increase. In addition, there will be a marked increase on the electricity demand if other sectors (e.g. industry, transport) will be electrified either directly or indirectly via electrolytic hydrogen. For this to realize massive investments in wind and solar energy will be needed. There have been concerns (e.g. Fasihi *et al.* 2017) that there might not be enough renewable energy available in the Europe or that the prices could be high. One option would thus be to produce hydrogen (or hydrocarbons) in locations where the renewable energy resources are abundant and then import them to the Europe. In the previous studies (Fasihi *et al.* 2016 & Fasihi *et al.* 2017) the Maghreb region (northwest Africa) and Patagonia (southern tip of South-America) were identified as potential locations for PV+wind hybrids due to high achievable capacity factors.

This study aims to determine the competitiveness of the LOHC concept in importing hydrogen from the Maghreb region to Finland and to identify the most important factors affecting the competitiveness. In addition to the LOHC concept, the other considered options are liquid hydrogen (LH2) and liquefied natural gas (LNG).

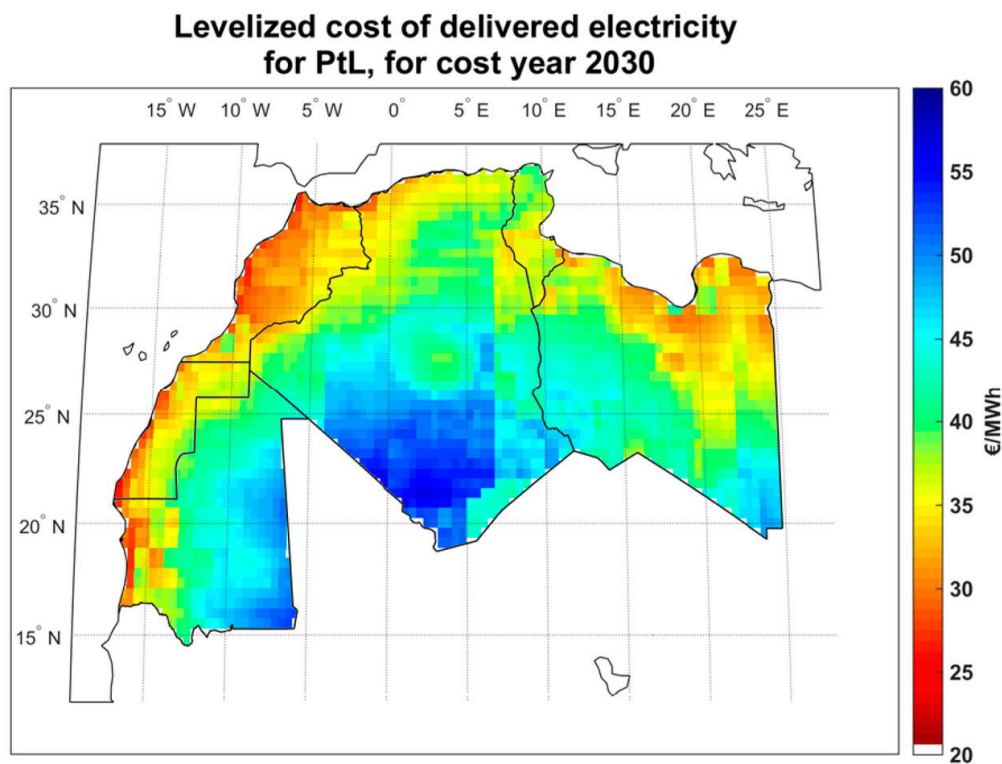

Figure 33. Levelized cost of delivered electricity in 2030 (Fasihi *et al.* 2017).

The considered supply chains are illustrated in Figure 34. Starting from the gaseous hydrogen, the supply chain for liquid hydrogen consists of liquefaction, transport and regasification steps. For LOHC the steps are hydrogenation, transport and dehydrogenation. For LNG, the first step is the synthesis of methane from hydrogen and CO<sub>2</sub>. CO<sub>2</sub> is assumed to be captured from the air to ensure the CO<sub>2</sub>-neutrality. This is followed by liquefaction, transportation and regasification and finally steam reforming to obtain H<sub>2</sub>. In addition, export and import terminals are required for each case.

Hydrogen is assumed to be used in an oil refinery. The scale of production corresponds to 400 MW (LHV) of delivered hydrogen at 8200 h/a full load operation. The delivered costs of imported hydrogen are compared to on-site production of hydrogen via steam methane reforming with CCS. Target year is 2030.

When necessary, investment costs were first scaled according to Eq. 4 and then annualized using a Weighted Average Cost of Capital (WACC) of 8% and lifetime of 20 years.

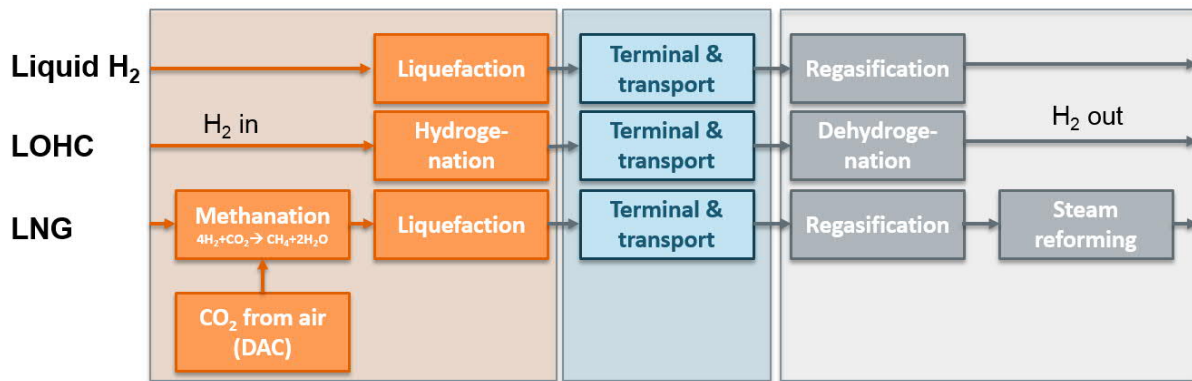

Figure 34. Supply chains for hydrogen import.

### 6.3.2 Hydrogen production

Rather than focusing on the hydrogen production costs, this study aims mainly to compare different hydrogen transport chains. Thus, a simplified approach is taken to calculate costs of hydrogen. The analysis is based on 5600 h/a full load hours and an average delivered cost of electricity of 35 €/MWh. These are in line with results by Fasihi *et al.* 2016 & 2017.

The investment cost of large-scale PEM electrolysis units including all the required auxiliaries and grid connection was assumed to decrease to 500 €/kWe by 2030. Operation and maintenance costs including stack replacement were assumed to be 5% of the CAPEX. The average efficiency during the lifetime of the electrolyser is 67% based on the lower heating value of hydrogen. No value was considered for the by-product oxygen or the low-temperature heat. The assumptions related to hydrogen production are listed in Table 6.

Table 6. Assumptions for hydrogen production via electrolysis

Parameter	Value
Investment cost	500 €/kWe
O&M (excl. electricity, including stack replacement)	5% of CAPEX
Specific electricity consumption	Efficiency 67% (LHV)
Full load hours	5600 h/a
Electricity price	35 €/MWh
Value of excess heat	0 €/MWh
Value of by-product oxygen	0 €/t

### 6.3.3 Hydrogen conversion

For simplicity, the full load hours for all the hydrogen conversion processes were considered to be the same as for the electrolyzers. In reality, due to lower flexibility of the processes

compared to electrolysis, some hydrogen storages would likely be required. If hydrogen would be stored e.g. in caverns, the full load hours of for hydrogen processing units could be higher and capacities could then be lower. Storing hydrogen would however incur additional costs.

Liquefaction of hydrogen is an energy and capital intensive process due to extremely low temperatures required. Cost and performance data (Table 6) for the hydrogen liquefaction unit are based on the design from IDEALHY project (Stolzenburg&Mubbala 2013). The investment costs for an advanced 70 MW<sub>H<sub>2</sub>,LHV</sub> liquefier were estimated to be 105 M€ and specific electricity consumption 6.76 kWh/kg<sub>H<sub>2</sub></sub>. Hydrogen losses were not considered.

For LOHC the investment costs (Table 6) for hydrogen conversion were calculated based on reference costs taken from Reus *et al.* (2017). The degree of hydrogenation was assumed to be 100%. Degradation of LOHC was not considered directly due to low frequency of hydrogenation/dehydrogenation cycles. However, no residual value was given for the LOHC fluid at the end of the considered time span which compensates the effect of degradation. Electricity consumption was not considered as it is negligible compared to electrolysis step (Eypasch *et al.* 2017). No value was assumed for the by-product heat although it could be used e.g. in desalination of seawater.

Methane can be synthesized from CO<sub>2</sub> and H<sub>2</sub> via the Sabatier reaction. The reaction is highly exothermic and typically the process is operated at 200–550 °C and 1–100 bar in the presence of nickel-based catalysts (Götz *et al.* 2016). With stoichiometric H<sub>2</sub>:CO<sub>2</sub> feed ratio of 4:1, methane conversion is maximized at 300 °C and 18 bar (Ciuta *et al.* 2016). For simplicity, full methane conversion was assumed. In reality the product gas would include a few percent of hydrogen and CO<sub>2</sub>. CO<sub>2</sub> should be separated before liquefaction to avoid freezing. Hydrogen would go through the SNG liquefaction and could be recycled back to methanation. Electricity consumption of the methanation step is not considered because it is minor compared to electrical demand for electrolyzers.

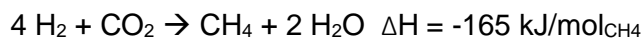

CO<sub>2</sub> for methanation is assumed to be captured from air (direct air capture, DAC) using solid adsorbents. Costs and performance data were taken from Fasihi *et al.* (2017) who based their performance numbers on the data from the DAC technology provider Climeworks. The main energy source for the process is low temperature heat (<100 °C). Theoretically waste heat from methanation can meet ~70% of the energy demand while the rest can be sourced from the electrolyzers. There is high uncertainty regarding investment costs due to immaturity of the technology especially for large-scale applications. The actual investment costs for the target year 2030 will be highly dependent on how widely will the technology be adopted by 2030.

Compression of CO<sub>2</sub> from 1 bar to 20 bar for methanation would add ~70 kWh/t<sub>CO<sub>2</sub></sub> to electricity consumption and increase specific investment costs by ~50 €/kg<sub>CO<sub>2</sub>/h</sub> (Hannula 2015). Hydrogen does not need to be compressed as the electrolyzers can be operated at 20 bar.

For the considered capacities, SNG liquefaction processes are typically based on either pre-cooled dual nitrogen expanders or single mixed refrigerant cycles (Bronfenbrenner *et al.* 2009). The specific electricity consumption for a single mixed refrigerant process is around 1400–1500 kJ/kg<sub>LNG</sub> (Khan&Lee 2013) and thus a value of 1450 kJ/kg<sub>LNG</sub> was adopted here.

Typical investment costs for LNG liquefaction trains are \$600–800/tpa while a complete liquefaction plant with all the required infrastructure and storage tanks is typically \$1000–1200/tpa (Songhurst 2014). In some locations, costs can be higher. Specific cost of \$800/tpa, which corresponds to ~350 €/kW<sub>LNG</sub>, was used in this study.

Table 7. Assumptions for the hydrogen conversion steps

Parameter	Value
<b>Hydrogen Liquefaction</b>	
Investment cost basis	70 MW <sub>H<sub>2</sub>,LHV</sub> = 105 M€ [1] Scale factor 0.8
O&M (excl. electricity)	4% of CAPEX [1]
Specific electricity consumption	6.76 kWh/kg <sub>H<sub>2</sub></sub> [1]
<b>LOHC Hydrogenation</b>	
Investment cost basis	40 M€ for 300 t/day (=417 MW <sub>H<sub>2</sub>,LHV</sub> ) [2] Scale factor 0.6 [2]
O&M	4% of CAPEX
Degree of hydrogenation	100%
Reaction enthalpy	-65 kJ/mol <sub>H<sub>2</sub></sub>
<b>Methanation</b>	
Investment cost basis	40 M€ for 200 MW <sub>CH<sub>4</sub></sub> [3] Scale factor 0.7 [3]
O&M	4% of CAPEX [3]
Degree of methanation	100%
<b>CO<sub>2</sub> capture (DAC, Direct Air Capture) &amp; compression</b>	
Investment cost basis	2000 €/(kg <sub>CO<sub>2</sub></sub> /h) [4] + 50 €/(kg <sub>CO<sub>2</sub></sub> /h) for compression Scale factor 1.0
O&M (excl. electricity & heat)	4% of CAPEX [4]
Specific electricity demand	225 kWh/t <sub>CO<sub>2</sub></sub> [4] + 70 kWh/t <sub>CO<sub>2</sub></sub> for compression
Specific heat demand	1500 kWh/t <sub>CO<sub>2</sub></sub> [4]
<b>Liquefaction of SNG (Single mixed refrigerant process)</b>	
Investment cost basis	350 €/kW <sub>LNG</sub> [5] Scale factor 1.0
O&M (excl. electricity)	4% of CAPEX
Specific electricity demand	1450 kJ/t <sub>LNG</sub> [6]
<b>Generic</b>	
Electricity price	35 €/MWh
Full load hours	5600 h/a
Value of excess heat	0 €/MWh

[1] Stolzenburg&Mubbala (2013) [2] Reus *et al.* (2017) [3] Brynolf *et al.* (2018) [4] Fasihi *et al.* (2017)  
[5] Songhurst (2014) [6] Khan&Lee (2013)

### 6.3.4 Terminals

The main cost components for a fuel terminal are the storage tanks, loading infrastructure and a jetty (Stelter&Nichida 2013). The main cost differences for the considered supply chains are assumed to be caused by the storage tanks. The required capacity of the storage tanks will depend on the capacities and trip times of the ships. Minimum storage size was considered to be the capacity of the ship plus three days production for buffer.

Costs for the LOHC storage tanks were determined based on costs of diesel/gasoline storage facilities. According to an IEA study (Stelter&Nichida 2013) above-ground storage facilities cost

140–180 €/m<sup>3</sup> (including loading facilities but excluding jetty) while the cost of a plain 50 000 m<sup>3</sup> storage tank is ~\$90/m<sup>3</sup> = 75 €/m<sup>3</sup> (scaling factor 0.77). According to the Twomey&Labett (2013) the specific investment cost for a 200 000 m<sup>3</sup> (2x40 000 m<sup>3</sup> + 3x60 000 m<sup>3</sup> tanks) storage facility for diesel/gasoline joined to an existing facility is 475 AUD/m<sup>3</sup> (~300 €/m<sup>3</sup>). Based on these estimates a value of 125 €/m<sup>3</sup> was adopted for a 50 000 m<sup>3</sup> tank. The cost of LOHC compound was also allocated terminals (and not for the conversion steps). The LOHC compound cost was divided evenly to the export and import terminals. Two future LOHC compound prices were considered: 2.5 and 1 €/kg.

Investment cost for a 170 000 m<sup>3</sup> LNG storage tank is 112.5 M€ (662 €/m<sup>3</sup>) according to Internal Gas Union (2015) while E4Tech (2015) estimated that a 16 000 m<sup>3</sup> storage tank for liquid hydrogen would cost 30 M€ (1875 €/m<sup>3</sup>).

Based on the realized total investment costs of LNG terminals built in Finland, the other terminal related costs were assumed to be 100 M€ for a 100 000 m<sup>3</sup> LNG storage. This includes site preparation, loading infrastructure and a jetty. For simplicity, the same cost was used also for the other delivery chains. For capacity scaling a scale factor of 0.7 was applied.

Boil-off losses for LH2 and LNG in terminals were excluded from the analysis. In large-scale storage tanks the boil-off rates are low (0.05–0.1%/day for LNG) and boil-off gases could be re-liquefied. This would, however, incur additional investments and electricity consumption.

The import and export terminals were considered to be identical.

	LOHC	LH2	LNG
Investment cost basis for storage tank	2x125 €/m <sup>3</sup> for 50 000 m <sup>3</sup> Scale factor 0.77 (two tanks are required)	1875 €/m <sup>3</sup> for 16000 m <sup>3</sup> [1] Scale factor 0.67	662 €/m <sup>3</sup> for 170 000 m <sup>3</sup> [2] Scale factor 0.67
LOHC fluid (DBT) price	Default 2.5 €/kg [3] Low 1 €/kg		
Other terminal costs (loading infra, jetty)	100 000 m <sup>3</sup> LNG storage = 100 M€ Scale factor 0.7		

[1] E4Tech 2015 [2] International Gas Union 2015 [3] Reus *et al.* 2017

### 6.3.5 Sea transport

For sea transport of LOHC, traditional tankers used for oil or chemicals are considered. The deadweight tonnages (DWT) for chemical tankers are typically below 50 000 t while crude tankers are available up to ~300 000 DWT.<sup>4</sup>

The capacity of LNG carriers can vary from small ~20 000 m<sup>3</sup> carriers up to 265 000 m<sup>3</sup> Q-max class carriers. Vast majority of the carriers currently operating are “Small Conventional” class carriers with typical capacity of 138 000 m<sup>3</sup> but higher capacities are becoming more and more common on new orders. (MAN Diesel & Turbo 2013)

There are no large-scale carriers for liquid hydrogen in operation today. The specifications for the LH2 carrier are based on the Kawasaki’s conceptual design (Kamiya *et al.* 2015) for a 160 000 m<sup>3</sup> carrier (Figure 35).

<sup>4</sup> Deadweight tonnage is the weight of all the cargo, fuel, dry provisions, supplies, etc. carried on board the ship so actual net cargo capacity is slightly lower.



Items	
Class of ship	Large ship (Spherical tank)
Type of Ship	Monohull ship
Tank capacity	160,000 m <sup>3</sup> (40,000m <sup>3</sup> x 4 unit)
Tank method	Spherical tank ,Type-B
Thermal insulation	Vacuum panel
BOG(Boil off gas rate)	0.2%/day
Propulsion system	Hydrogen gas engine

Figure 35. Conceptual design of a 160 000 m<sup>3</sup> liquid hydrogen carrier. (Kamiya et al. 2015)

LNG and LH2 carriers are assumed to be run with boil-off gas. For the LOHC tanker two options could be considered: either 1) hydrogen released from LOHC or 2) external renewable or CO<sub>2</sub>-neutral fuel such as methanol or LNG produced from CO<sub>2</sub> and H<sub>2</sub>. Using LOHC as fuel was not considered feasible as waste-heat from engines could cover only a small fraction of the required dehydrogenation heat and solid oxide fuel cells were not considered a likely option for 2030. The cost for the CO<sub>2</sub>-neutral fuel was assumed to be 100 €/MWh.

The average fuel consumptions were estimated by assuming average engine load to be 75% of the specified maximum continuous rating (SMCR) and an engine efficiency of 50% regardless of the fuel. Mainly due to slower cruising speed, the average fuel consumption for the LH2 carrier is lower compared to the LNG carrier.

All the assumptions related to sea transport are listed in Table 8. Actual required capacities of the tankers will be calculated.

Table 8. Assumptions for sea transport

	LOHC tanker	LH2 carrier	LNG carrier
<b>Investment cost basis</b>	45 000 DWT = 35 M€ [1] Scaling factor = 0.7	160 000 m <sup>3</sup> = 362 M€ [2] Scaling factor = 0.7	138 000 m <sup>3</sup> = 151 M€ [3] Scaling factor = 0.7
<b>OPEX (excl. fuel)</b>	2% of CAPEX	2% of CAPEX	2% of CAPEX
<b>Avg cruising speed</b>	14 knots = 27.8 km/h	16 knots = 30 km/h [2]	20 knots = 37 km/h [3]
<b>Specified maximum continuous rating (SMCR)</b>	9 MW [1]	20 MW [5]	28 MW [4]
<b>Estimated average fuel power (75% SMCR, 50% efficiency)</b>	13.5 MW Scaling factor = 0.6	30 MW Scaling factor = 0.6	42 MW Scaling factor = 0.6
<b>Cost of external fuel</b>	100 €/MWh		
<b>Cargo handling at terminals (unloading and loading)</b>	2+2 days	2+2 days	2+2 days
<b>Distance (one-way)</b>	5000 km	5000 km	5000 km

[1] Teichmann et al. 2012 [2] Kan&Shibata 2018 [3] Fasihi et al. 2017 [4] MAN Diesel & Turbo 2013 [5] VTT estimation

### 6.3.6 Hydrogen release

For LOHC dehydrogenation investment costs were calculated based on a reference cost of 30 M€ for a 300 t/day unit using a scaling factor of 0.6 based on Reus et al. (2017). Complete dehydrogenation was assumed similarly to Reus et al. (2017). In the reference case, the heat for the hydrogen release was assumed to be carried out with external renewable heat valued



at 40 €/MWh. The availability of free waste-heat was also considered separately. Table 9 shows the assumptions for releasing hydrogen from LOHC.

Table 9. Assumptions for LOHC dehydrogenation (Reus et al. 2017)

Parameter	Value
Investment cost basis	30 M€ for 300 t <sub>H2</sub> /day (=417 MW <sub>H2,LHV</sub> ) [1] Scale factor 0.6 [1]
O&M (excl. electricity)	4% of CAPEX [1]
Specific electricity consumption	0.37 kWh/kg <sub>H2</sub>
Degree of dehydrogenation	100%
Reaction enthalpy	65 kJ/mol H <sub>2</sub>
Heat supply	External supply
External renewable heat price	40 €/MWh

[1] Reus et al. (2017)

The investment costs for the regasification of liquid hydrogen with a capacity of 8000 kg/h (267 MW<sub>H2,LHV</sub>) is 1.3 M€ according to the H2A model (NREL 2010) and the specific electricity demand 0.6 kWh/kg<sub>H2</sub> (Reus et al. 2017).

For LNG the gas is first regasified and then fed to a steam reformer which can be either an existing one or a new one. Based on the regasification costs for liquid hydrogen, the regasification cost is negligible compared to reforming step and was thus excluded from the analysis due to lack of actual cost data. Table 10 lists the values used for steam reforming.

Table 10. Assumptions for steam reforming of SNG (IEAGHG 2017)

Parameter	Value
Investment cost	300MW <sub>H2,LHV</sub> = 223 M€ Scale factor 0.75
O&M (excl. electricity)	3.5% of CAPEX
Efficiency (H <sub>2</sub> <sub>out</sub> /CH <sub>4</sub> <sub>in</sub> LHV/LHV)	76%
Excess electricity produced	0.03 MW <sub>e</sub> /MW <sub>H2</sub>

### 6.3.7 On-site hydrogen production at the refinery - SMR with CCS

The total imported costs of renewable hydrogen are compared to a case where hydrogen is produced at the refinery via steam methane reforming combined with carbon capture and storage. CO<sub>2</sub> is assumed to be captured from the reformer flue gases in order to have maximal CO<sub>2</sub> capture rate. As there are no suitable CO<sub>2</sub> storages in Finland, CO<sub>2</sub> would have to be transported via ships e.g. to Sleipner, Norway.

Table 11 lists the assumptions for the on-site hydrogen production. Investment costs are for a greenfield plant. Brownfield investment is evaluated separately. As hydrogen is assumed to be used in oil refining, natural gas is completely free of excise tax (chapter 5.2). This also makes the results more universal.

Table 11. Assumptions for hydrogen production in Finland via steam methane reforming and CCS (from the reformer flue gases)

Parameter	Value
Investment cost basis	300MW <sub>H<sub>2</sub>,LHV</sub> = 398 M€ [1] Scale factor 0.75
O&M (excl. electricity)	3.5% of CAPEX [1]
Efficiency (H <sub>2</sub> <sub>out</sub> /CH <sub>4</sub> <sub>in</sub> LHV/LHV)	69% [1]
Excess electricity produced	Negligible [1]
CO <sub>2</sub> capture rate (capture from reformer flue gases)	89% [1]
Full load hours	8200 h/a
CO <sub>2</sub> transport and storage cost	40 €/t <sub>CO<sub>2</sub></sub>
CO <sub>2</sub> emission allowance price	40 €/t <sub>CO<sub>2</sub></sub>
Natural gas price	30-40 €/MWh
Natural gas tax	0 €/MWh

[1] IEAGHG 2017

### 6.3.8 Results

Table 12 lists the total trip times, tanker/carrier capacities and required storage sizes for the terminals. The differences in total trip times are due to different cruising speeds (Table 8). The required vessel capacities were determined by assuming that one tanker/carrier is used, which then fixed also the required storage tank sizes.

Table 12. Sea transport related results

Parameter	LOHC	LH2	LNG
Total trip time (Maghreb-Finland)	19 d	18 d	15 d
Tanker/carrier capacity	87 000 t	76 000 m <sup>3</sup>	40 500 m <sup>3</sup>
Terminal storage tank size	110 000 m <sup>3</sup> (x2)	95 000 m <sup>3</sup>	50 000 m <sup>3</sup>
Number of tankers/carriers	1	1	1

The total delivered costs of hydrogen are shown in Figure 36, which also shows the costs of hydrogen by on-site steam methane reforming with CCS (horizontal lines) assuming natural price range of 30–40 €/MWh and greenfield investment for the reformer. The delivered costs of hydrogen range from ~3.8 to 5.5 €/kg and are higher than the costs for on-site production 2.4–2.9 €/kg. A brownfield investment or retrofitting an existing reformer with CCS would further reduce the costs of the on-site option by 10–15%. LOHC and LH2 supply chains lead to similar costs of delivered hydrogen when the price for the LOHC compound is 2.5 €/kg while the price 1.0 €/kg would make the LOHC chain most feasible option for hydrogen import. Both of the used LOHC compound prices included an assumption of a cost reduction from the current level (4 €/kg). This was seen justified as the prices tend to decrease when the demand increases.

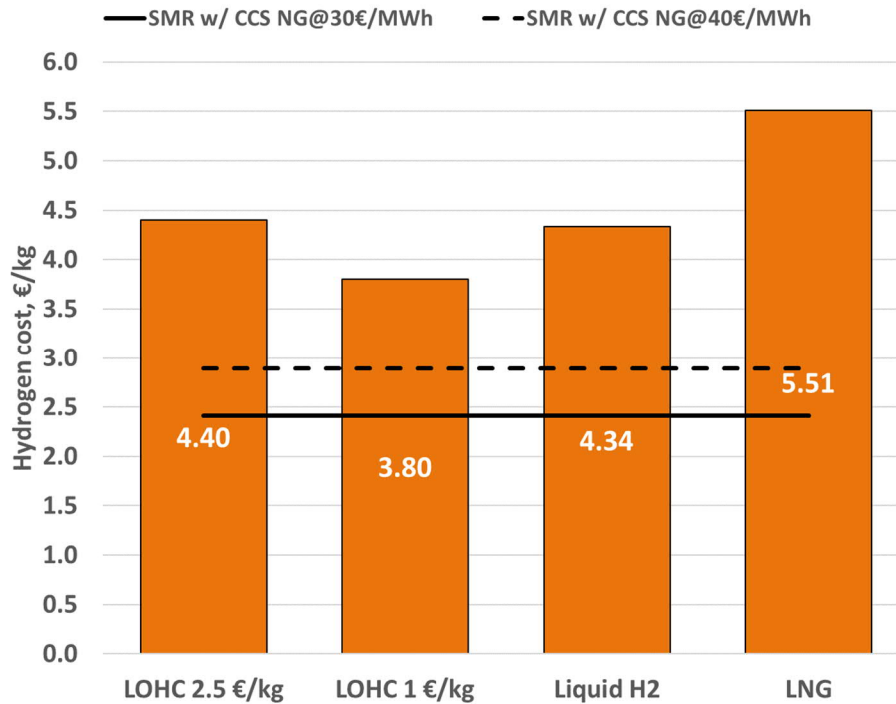

Figure 36. Delivered costs of renewable hydrogen from the Maghreb region to Finland in the reference case and costs for on-site hydrogen production via SMR with CCS. (2.5 €/kg and 1.0 €/kg refer to the assumed prices of the LOHC compound (DBT)).

Figure 37 shows the distributions of costs between delivery chain steps. Hydrogen losses have been considered as costs and are allocated to the corresponding delivery step in which they have occurred. For example, the boil-off gases used as a fuel for the LNG/LH2 carriers add to the cost of the shipping steps.

Hydrogen production is a major cost component for each case corresponding to ~40–60% of the total delivered costs. For electrolytic hydrogen production, the electricity costs are the dominating cost component.

For LOHC chains, the conversion (=hydrogenation) costs make up only a very minor share of the costs due to the economies of scale. Hydrogen release costs are higher due to consumption of CO<sub>2</sub>-free heat valued at 40 €/MWh. If dehydrogenation heat could be supplied free of charge, the costs would drop by ~0.35 €/kg. The terminal costs for LOHC are high compared to LH2 or LNG cases, because the cost of LOHC compound were allocated to terminals rather than conversion and release steps. Due to large tankers and long trip times relatively large storage tanks are required (Table 12). LOHC storage costs are mainly governed by the cost of the LOHC compound.

Due to the capital intensiveness of the liquefaction process the conversion costs are high for LH2 despite the assumed low electricity prices. Sea transport is around two times more expensive than for the other options due to the high cost of the LH2 carrier. However, the release costs are minimal as only regasification is required.

For LNG the conversion costs are very high due to hydrogen losses. Conversion processes themselves correspond to ~30% of the costs while the rest is due to costs allocated to hydrogen losses taking place in methanation. For the same reason the costs for releasing hydrogen are also high. Hydrogen losses during steam methane reforming make up 70% of the hydrogen release costs. If LNG would be used in an existing reformer, conversion costs would drop only by ~0.4 €/kg. Thus, if the aim is to obtain hydrogen, LNG is not a competitive

option. However, LNG could be used directly for example as a transport fuel or for energy production. The delivered costs of LNG would be ~120 €/MWh (LHV).

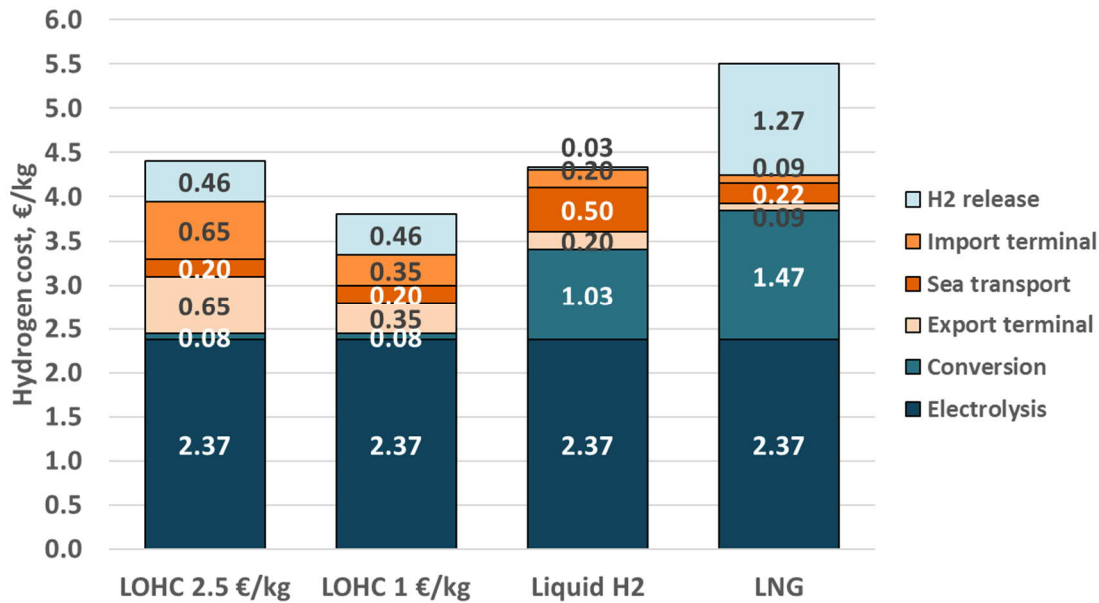

Figure 37. Cost distributions for the renewable hydrogen delivery chains from the Maghreb region to Finland in the reference case. (2.5 €/kg and 1.0 €/kg refer to the assumed prices of the LOHC compound (DBT)).

In the analysis it was initially assumed that one large tanker/carrier is used resulting in an 87 000 DWT tanker for the LOHC (Table 12). For the LOHC cases, slightly lower costs (-0.37 or -0.13 €/kg depending on the LOHC compound price) could be achieved by using two smaller tankers which would enable smaller storages and thus reduce the required amount of the LOHC compound. For LH2 and LNG the utilisation of one large carrier was the most economical option. The effect of the selected number of tankers and sufficient storage sizes would become even more pronounced if transport distance would be even longer. For example the distance to Patagonia – the other identified potential location – is 13 400 km.

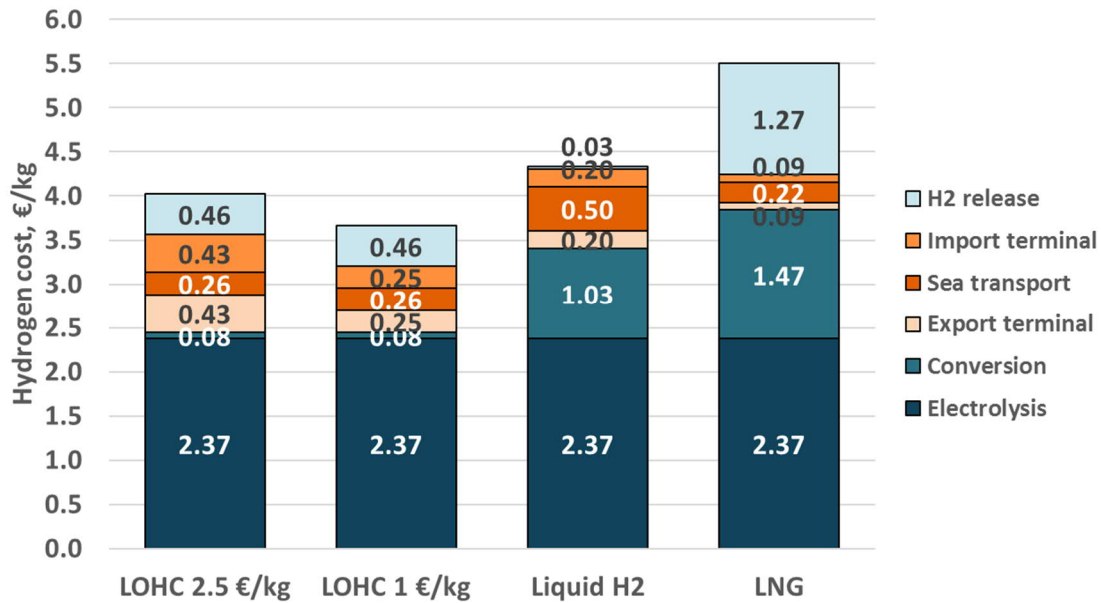

Figure 38. Cost distributions for the renewable hydrogen delivery chains from the Maghreb region to Finland assuming two smaller tankers for the LOHC chains. (2.5 €/kg and 1.0 €/kg refer to the assumed prices of the LOHC compound (DBT)).

### 6.3.9 Sensitivity analysis

As hydrogen production is a significant cost component for the hydrogen import options, the competitiveness of hydrogen import against on-site steam reforming is highly dependent on the electricity price in the exporting country as well as natural gas price in the importing country as indicated by Figure 39. Even at high natural gas prices, electricity would have to be available at a very low cost. For example, at natural gas price of 50 €/MWh, the break-even electricity prices for imported hydrogen are 10–26 €/MWh depending on the delivery chain. Electricity price has the highest impact on the LNG chain mainly due to high hydrogen losses requiring more hydrogen production capacity to meet the same demand.

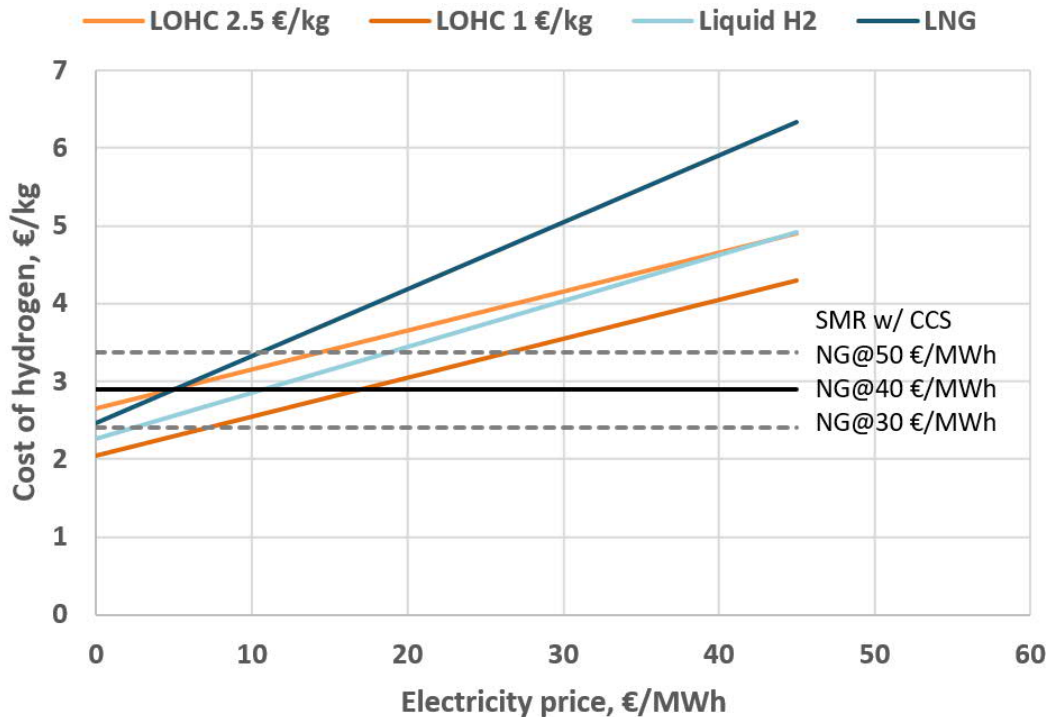

Figure 39. The effect of electricity price on the competitiveness of imported hydrogen against on-site reforming with CCS at different natural gas prices.

Sensitivity towards attainable full load hours and less than ideal LOHC reaction performance was also studied (Table 13). The effect of full load hours is higher for LH2 and LNG chains compared to LOHC chains due to their higher capital intensiveness. High full load hours would necessitate the use of additional energy input to PV+Wind.

In the reference case ideal hydrogenation and dehydrogenation were assumed. Less than ideal conversion will not only increase the required amount of the LOHC compound but also increases the required storage tank and tanker sizes. At high LOHC compound prices the cost increases can become significant.

Table 13. Sensitivity analysis

Parameter	LOHC (2.5 €/kg)	LOHC (1.0 €/kg)	LH2	LNG
	€/kg H <sub>2</sub>	€/kg H <sub>2</sub>	€/kg H <sub>2</sub>	€/kg H <sub>2</sub>
Reference case	4.40	3.80	4.34	5.51
Full load hours 5600 → 7500 h/a	4.17 (-0.23)	3.60 (-0.20)	3.95 (-0.39)	5.02 (-0.49)
Full load hours 5600 → 6500 h/a	4.28 (-0.12)	3.69 (-0.11)	4.13 (-0.21)	5.26 (-0.25)
Full load hours 5600 → 5000 h/a	4.51 (+0.11)	3.90 (+0.10)	4.51 (+0.17)	5.72 (+0.21)
Full load hours 5600 → 4000 h/a	4.77 (+0.37)	4.12 (+0.32)	4.92 (+0.58)	6.22 (+0.71)
Degree of dehydrogenation 100 → 90%	4.54 (+0.14)	3.87 (+0.07)		
Degree of dehydrogenation 100 → 80%	4.71 (+0.31)	3.95 (+0.15)		

### 6.3.10 Summary and conclusions

The delivered costs of hydrogen ranged from ~3.8 to 5.5 €/kg and were higher than the costs for on-site production by natural gas reforming equipped with carbon capture and storage (2.4–2.9 €/kg). LOHC concept was found to be the most feasible import option in the studied case followed by liquid hydrogen. LNG chain leads to high costs due to hydrogen losses in the conversion steps.

The delivery chains increased the costs of hydrogen by ~40–130%. More frequent deliveries with smaller tankers – which enables also smaller terminal storage tanks – were found to be beneficial for the LOHC concept due to the relatively high price of LOHC compound (Table 14). Utilisation of waste-heat or low cost heat for dehydrogenation would further improve the LOHC chain economics. As opposed to case 1, the capital costs of LOHC reactors were found to have only a very a minor effect due to economies of scale.

The overall feasibility of hydrogen import will depend on the respective development of electricity and natural gas prices in future.

*Table 14. Delivered costs of hydrogen in €/kg in the reference case and the considered possible improvements*

Parameter	LOHC (2.5 €/kg)	LOHC (1.0 €/kg)	LH2	LNG
	€/kg H <sub>2</sub>	€/kg H <sub>2</sub>	€/kg H <sub>2</sub>	€/kg H <sub>2</sub>
Reference case	4.40	3.80	4.34	5.51
Two smaller LOHC tankers	4.03 (-0.37)	3.67 (-0.13)		
Free heat for dehydrogenation	4.00 (-0.40)	3.40 (-0.40)		
Free heat + smaller tankers	3.63 (-0.77)	3.27 (-0.53)		
Existing steam reformer for LNG				5.12 (-0.39)

## 7. Summary and conclusions

---

This report aimed to identify the advantages and possible limitations of the Liquid Organic Hydrogen Carrier (LOHC) technology and evaluate the feasibility in the Finnish context in selected applications.

The strengths, weaknesses, opportunities and threats for the LOHC concept are summarized in Table 15. Generally speaking, the applications, in which hydrogen is needed as a reactant rather than using it as an energy source, were seen more economically attractive for the LOHC concept at least in the near-term. There is not yet real market for long-term energy storage or enough variation in electricity prices, and other options such as synthetic hydrocarbons could prove to be more favourable as they could be used in existing power plants. In addition, there is a distinct advantage for the LOHC concept compared to hydrocarbons (or ammonia) when hydrogen is used as a reactant. Hydrogen is released as the sole end-product from LOHC (with minor impurities) while hydrocarbons would result in a mixture of CO<sub>2</sub> and H<sub>2</sub> requiring and additional separation step. Also, the applications which involve long-distance transportation of hydrogen will favour the LOHC concept.

While the LOHC concept provides a means to transport and store hydrogen efficiently, safely and without storage losses, the high reaction enthalpies and high temperatures (~300–350 °C) required for releasing hydrogen can be a challenge for the economics. Should hydrogen release be carried out by burning part of the hydrogen, ~30% of the hydrogen would be consumed. The same amount of heat is released when hydrogen is bound but at lower temperature (~150 °C), and for economic feasibility it is important to find use for this heat. Equally important would be to utilise waste-heat to release the hydrogen but waste-heat with sufficient temperature is not often available. In the future, the development of new LOHC compounds having lower reaction enthalpies and new catalysts for decreasing the dehydrogenation temperatures should be targeted.

The techno-economic feasibility of the LOHC concept was evaluated in more detail in two case studies.

*Case 1* considered the logistics of by-product hydrogen from chlorate/chlor-alkali electrolysis to light industry, which was identified as a possible low-hanging fruit for the LOHC concept to enter the markets. The study revealed that LOHC concept can be a viable option when transport distances are >100–200 km if the capital costs for the conversion reactors are in the lower-end of the literature estimates. Due to the immaturity of the LOHC technology, the investment cost estimates include a significant uncertainty still. In the study, it was assumed that hydrogen is burned to supply the heat for releasing hydrogen and the availability of waste or low-cost heat was shown to improve the economics markedly. The higher the hydrogen demand and especially longer the transport distance, the better the LOHC chain's economics looked compared to delivery as compressed gas. This is due to the fact that for the LOHC concept, the costs were mainly governed by hydrogen processing costs while for the gaseous hydrogen delivery the trucking costs were more important.

*Case 2* looked a bit further into the future and considered the import of renewable hydrogen from North-West Africa to Finland to be used in an oil refinery. The LOHC chain was compared to liquid hydrogen and liquefied synthetic methane options. The costs for imported hydrogen were found to be quite high with conversion and transportation steps increasing the hydrogen delivery costs by 40–130%, which made the on-site hydrogen production via steam methane reforming equipped with Carbon Capture and Storage (CCS) more economically attractive solution. However, should the need to import hydrogen arise, the LOHC concept was found to be the most feasible option in the studied case. The feasibility of hydrogen import will depend on the respective development of electricity and natural gas prices in future. As opposed to case 1, the price of the LOHC compound had a significant effect on costs because large storage tanks are required when the shipment frequencies or are in the range of weeks. Thus, the utilisation of smaller tankers rather than maximising the tanker size was found to be



favourable in the case of LOHC. As future work, comparison of LOHC to ammonia would be interesting.

Results from cases 1 and 2 suggest that no single LOHC compound will likely be optimal for every application. E.g. for sea transport, a lower cost LOHC compound with higher degradation could be favourable while the applications requiring frequent hydrogenation/dehydrogenation cycles, could afford to pay extra for the LOHC compound having low degradation rates.

In future, the demand for large-scale long-term energy storages will arise due to increased shares of intermittent solar and wind power. This demand will likely first arise in smaller off-grid solutions (e.g. islands) rather than in a country or a continent level. There could also be similar storage needs within large-scale industrial hydrogen consumers. For example, if steel industry would adopt hydrogen-based direct reduced iron process or if oil refineries would substitute steam methane reforming with water electrolysis, the LOHC concept could enable storing of hydrogen, which would make the operation of the electrolyzers more flexible. These could open other interesting possibilities for the LOHC concept. For these purposes the “OneReactor concept” (Jorschick *et al.* 2017), in which dehydrogenation and hydrogenation would be carried out in a single reactor, would be particularly interesting.

Table 15. SWOT analysis for the LOHC concept

Strengths	Weaknesses
<ul style="list-style-type: none"> <li>• Distribution and storage compatible with existing infrastructure</li> <li>• High truck payloads compared to compressed gas</li> <li>• Safety</li> <li>• No storage loss: suitable for long-term storage</li> <li>• No major by-products in the released hydrogen stream (as opposed to hydrocarbons or ammonia)</li> </ul>	<ul style="list-style-type: none"> <li>• High reaction enthalpy - high heat demand for releasing hydrogen (~30% of the hydrogen should be burned to provide the heat)</li> <li>• Release of hydrogen requires relatively high temperature (~300–350 °C) making the utilisation of waste-heat challenging</li> <li>• Hydrogen is released at low pressure (1–5 bar) - high compression demand e.g. for mobility applications</li> <li>• Dedicated tanks are required also for the hydrogen-lean LOHC and it needs to be transported back to the hydrogenation plant</li> </ul>
Opportunities	Threats
<ul style="list-style-type: none"> <li>• Development of new (low-cost) LOHC compounds to enable significantly lower reaction enthalpies and/or new catalysts to decrease the required dehydrogenation temperatures</li> <li>• Combination to solid oxide fuels cells (SOFC) which would provide heat integration possibilities</li> <li>• Cost-efficient long-distance road transport also in smaller scale than with liquid H<sub>2</sub></li> <li>• Import/export of hydrogen</li> <li>• Off-grid and backup solutions</li> <li>• Long-term energy storage</li> </ul>	<ul style="list-style-type: none"> <li>• New uses for pure hydrogen do not emerge - e.g. electric cars &amp; synthetic hydrocarbons emerge as winners</li> <li>• Decreasing cost of on-site hydrogen generation via water electrolysis reduces the need to transport hydrogen</li> <li>• Purity of the released hydrogen not sufficient for PEM fuel cells without expensive purification</li> </ul>

## References

---

- Aakko-Saksa, P., Repo, T., Kiviaho, J. & Cook, C. (2018). Liquid organic hydrogen carriers for transportation and storing of renewable energy – Review and discussion, *Journal of Power Sources* 396 (2018) pp. 803–823.
- Antiniotti. (2013). Impact of high capacity CGH<sub>2</sub>-trailers, DeliverHy project deliverable 6.4, 33 p.
- Arlt, W. (2017). Wasserstoff und Speicherung im Schwerlastverkehr, Förderkennzeichen 03B 108001/LOHC, Friedrich-Alexander University, Erlangen-Nürnberg, 101 p. (In German)
- Bronfenbrenner, J.C., Pillarella, M. & Solomon, J. (2009). Review the process technology options for the liquefaction of natural gas, LNGINDUSTRY.COM.
- Brynolf, S., Taljegard, M., Grahn, M. & Hansson, J. (2018). Electrofuels for the transport sector: A review of production costs, *Renewable and Sustainable Energy Reviews* 81, pp. 1887–1905.
- Chiuta, S., Engelbrecht, N., Human, G., & Bessarabov, D.G. (2016) Techno-economic assessment of power-to-methane and power-to-syngas business models for sustainable carbon dioxide utilization in coal-to-liquid facilities, *Journal of CO<sub>2</sub> Utilization* 16, pp 399–411.
- E4Tech (2015). Scenarios for deployment of hydrogen in contributing to meeting carbon budgets and the 2050 target, Final Report, 149 p.
- Eypasch, M., Schimpe, M., Kanwar, A., Hartmann, T., Herzog, S., Frank, T. & Hamacher, T. (2017). Model-based techno-economic evaluation of an electricity storage system based on Liquid Organic Hydrogen Carriers, *Applied Energy* 185, pp. 320–330.
- Fasihi, M., Bogdanov, D. & Breyer, C. (2017). Long-Term Hydrocarbon Trade Options for the Maghreb Region and Europe—Renewable Energy Based Synthetic Fuels for a Net Zero Emissions World. *Sustainability*, Vol. 9, No. 2, p. 306.
- Fasihi, M., Bogdanov, D. & Breyer, C. (2016). Techno-Economic Assessment of Power-to-Liquids (PtL) Fuels Production and Global Trading Based on Hybrid PV-Wind Power Plants, *Energy Procedia* 99, pp. 243–268.
- FCHJU. (2017). Early business cases for H<sub>2</sub> in energy storage and more broadly power to H<sub>2</sub> applications, Final Report, Fuel cells and hydrogen joint undertaking, P2H-BC/4NT/0550274/000/03.
- Götz, M., Lefebvre, J., Mörs, F., McDaniel Koch, A., Graf, F., Bajohr, S., Reimert, R. & Kolb, T. (2016). Renewable Power-to-Gas: A technological and economic review, *Renewable Energy*, Volume 85, 2016, pp. 1371–1390, <https://doi.org/10.1016/j.renene.2015.07.066>.
- NREL. (2010). H<sub>2</sub>A Hydrogen Delivery Component Model - Version 2.2, National Renewable Energy Laboratory (NREL).
- Hannula, I. (2015). Synthetic fuels and light olefins from biomass residues, carbon dioxide and electricity, Doctoral Dissertation, VTT Science 107, 118 p.
- HYBRIT (2018). Summary of findings from HYBRIT Pre-Feasibility Study 2016–2017, SSAB, LKAB, Vattenfall, 20 p.

- Hydrogen Council (2017). Hydrogen scaling up - A sustainable pathway for the global energy transition, Hydrogen Council, November 2017, 78 p.
- Hydrogenious GmbH. (2016). Systems for safe and efficient hydrogen storage and logistics via LOHC Erlangen, May 2016.
- IEA (2015). Technology Roadmap - Hydrogen and Fuel Cells, IEA Publications, Paris, France, 75 p.
- IEAGHG. (2017). Techno-Economic Evaluation of SMR Based Standalone (Merchant) Hydrogen Plant with CCS, Technical Report 2017-2, Cheltenham, UK.
- International Gas Union (2015). Small Scale LNG, 2012 – 2015 Triennium Work Report, June 2015 Program Committee D3.
- Jorschick, H., Preuster, P., Dürr, S., Seidel, A., Müller, K., Bösmann, A. & Wasserscheid, P. (2017). Hydrogen storage using a hot pressure swing reactor, Energy Environ. Sci., 10, pp. 1652–1659.
- Kamiya, S., Nishimura, M. & Harada, E. (2015). Study on Introduction of CO<sub>2</sub> Free Energy to Japan with Liquid Hydrogen. Physics Procedia 67, pp. 11–19.
- Kan, S. & Shibata, Y. (2018). Evaluation of the Economics of Renewable Hydrogen Supply in the APEC Region, 34th Conference on Energy, Economy, and Environment, Japan Society of Energy and Resources (JSER).
- Khan, M.S. & Lee, M. (2013) Design optimization of single mixed refrigerant natural gas liquefaction process using the particle swarm paradigm with nonlinear constraints, Energy 49 (2013) 146e155
- Kärkkäinen, H. (2015). Vedyn käytön tarkastelu Kemira Chemical Oy:n Joutsenon tehtailla ("The analysis of the use of hydrogen at Kemira Chemicals Oy Joutseno plant"), Master's Thesis, LUT School of Engineering Science, 60 p. (In Finnish)
- MAN Diesel & Turbo. (2013), Propulsion Trends in LNG Carriers, 19 p.
- Mezler, D., Delgado, O., Rodriguez, F. & Muncied R. (2018). European heavy-duty vehicles: Cost-effectiveness of fuel efficiency technologies for long-haul tractor-trailers in the 2025–2030 timeframe EUROPEAN, ICCT White paper, International Council on Clean Transportation, 74 p.
- MYRDD. (2015). Fuel Cell Technologies Office Multi-Year Research, Development, and Demonstration Plan - 3.2. Hydrogen Delivery <https://energy.gov/eere/fuelcells/downloads/fuel-cell-technologies-office-multi-year-research-development-and-22>
- Reus, M., Grube, T., Robinius, M., Preuster, P., Wasserscheid, P. & Stolten, D. (2017). Seasonal storage and alternative carriers - A flexible hydrogen supply chain model, Applied Energy 200 (2017), pp. 290–302.
- Schneider, M.J. (2015). Hydrogen storage and distribution via liquid organic carriers, Bridging Renewable Electricity with Transportation Fuels Workshop, Brown Palace Hotel, Denver, CO, August 27-28<sup>th</sup>, 2015.
- Shell. (2017). Shell Hydrogen Study: Energy of the Future? Sustainable Mobility through Fuel Cells and H<sub>2</sub>, Hamburg, Germany.

- Songhurst, B. (2014). LNG Plant Cost Escalation, OIES Paper: NG 83, The Oxford Institute for Energy Studies, 33 p.
- Staffell, I. & Dodds, P.E. (eds.). (2017). The role of hydrogen and fuel cells in future energy systems, H2FC SUPERGEN, London, UK.
- Stolzenburg, K. & Mubbala, R. (2013). Hydrogen Liquefaction Report (D3.16), Integrated Design for Demonstration of Efficient Liquefaction of Hydrogen (IDEALHY) Fuel Cells and Hydrogen Joint Undertaking (FCH JU).
- Teichmann, D., Arlt, W. & Wasserscheid, P. (2012). Liquid Organic Hydrogen Carriers as an efficient vector for the transport and storage of renewable energy, International Journal of Hydrogen Energy, Volume 37, Issue 23, pp. 18118–18132.
- Twomey, I. & Labett, T. (2013). Australia's Emergency Liquid Fuel Stockholding Update 2013: Oil Storage Options & Costs, Hale & Twomey Limited & Aurecon.
- U.S. Drive (2013). Hydrogen Delivery Technical Team Roadmap, United States Driving Research and Innovation for Vehicle efficiency and Energy sustainability, 48 p.
- Yang, C. & Ogden, J. (n.d). Determining the lowest-cost hydrogen delivery mode, University of California, Davis, 30 p.

## Appendix A. Hydrogen production – process flowsheets

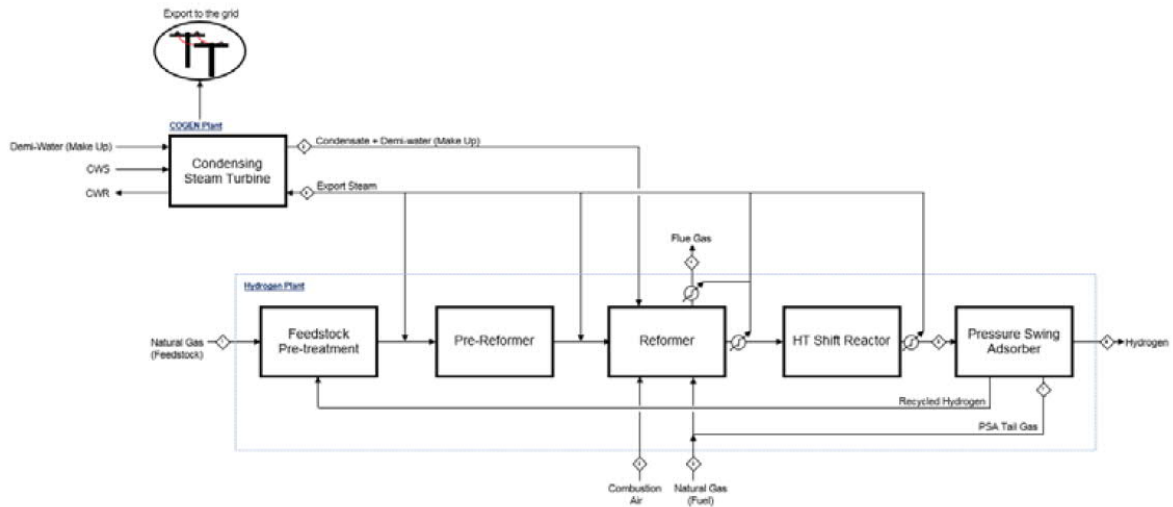

Figure A-1. Process flowsheet for large-scale SMR without Carbon Capture and Storage. (IEAGHG 2017)

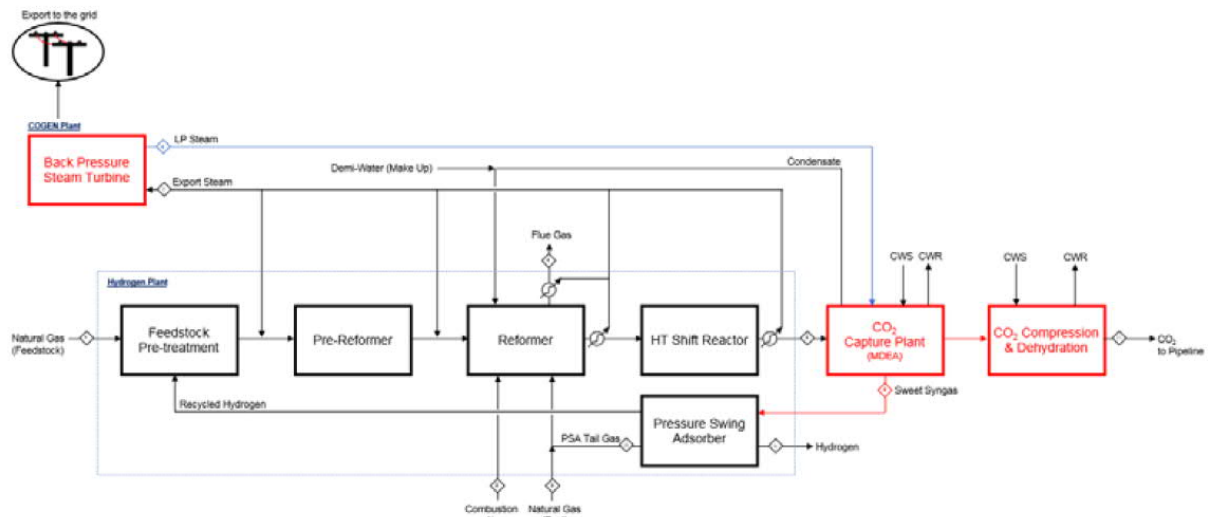

Figure A-2. Process flowsheet for large-scale SMR with Carbon Capture and Storage from shifted syngas. (IEAGHG 2017)

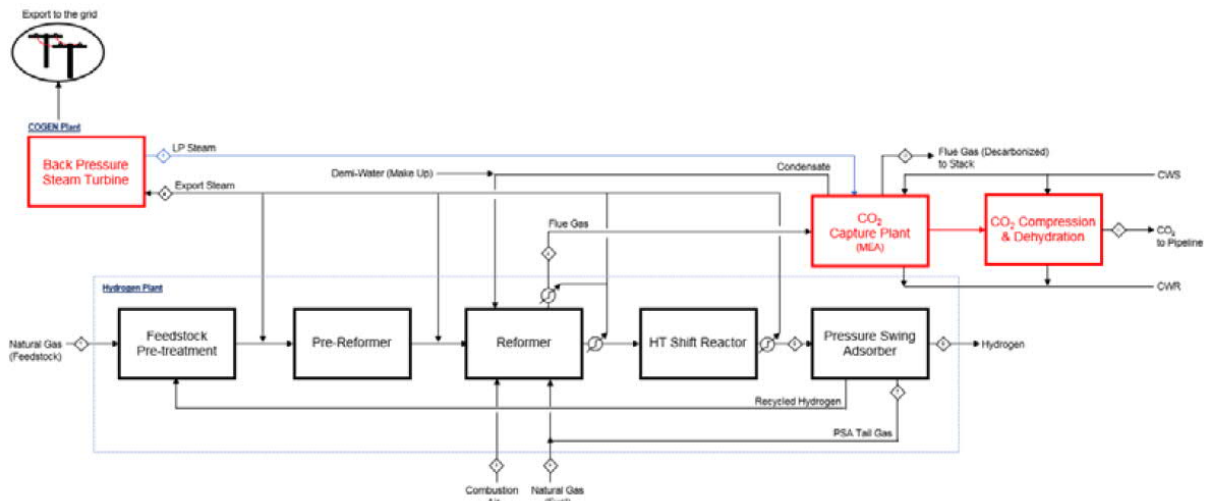

Figure A-3. Process flowsheet for large-scale SMR without Carbon Capture and Storage from reformer flue gases. (IEAGHG 2017)

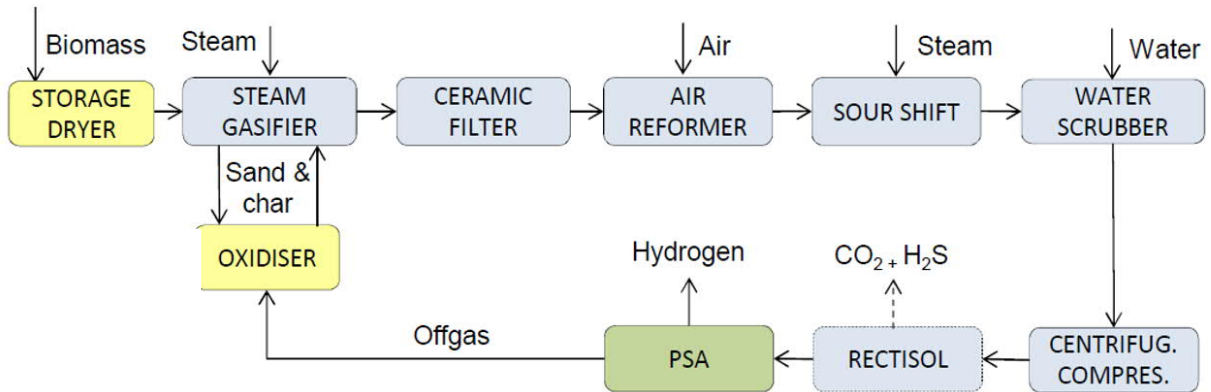

Figure A-4. Process flowsheet for indirect steam gasification of biomass.