

## THE ANALYSIS OF SBWR CRITICAL POWER BUNDLE USING COBRAG CODE

Yohannes Sardjono<sup>\*)</sup>, Masanori Aritomi<sup>\*\*)</sup>, Larry E. Fennern<sup>\*\*\*)</sup>

\*)Research and Development Centre for Advanced Technology BATAN

e-mail: gbianugerah@yahoo.com

\*\*)Tokyo Institute of Technology

e-mail: maritomi@nr.titech.ac.jp

\*\*\*)General Electric Hitachi Nuclear Energy

e-mail: larry.fennern@ge.com

Diterima editor 03 Oktober 2011

Disetujui untuk publikasi 14 November 2011

### ABSTRACT

**THE ANALYSIS OF SBWR CRITICAL POWER BUNDLE USING COBRAG CODE.** *The coolant mechanism of SBWR is similar with the Dodewaard Nuclear Power Plant (NPP) in the Netherlands that first went critical in 1968. The similarity of both NPP is cooled by natural convection system. These coolant concept is very related with same parameters on fuel bundle design especially fuel bundle length, core pressure drop and core flow rate as well as critical power bundle. The analysis was carried out by using COBRAG computer code. COBRAG computer code is GE Company proprietary. Basically COBRAG computer code is a tool to solve compressible three-dimensional, two fluid, three field equations for two phase flow. The three fields are the vapor field, the continuous liquid field, and the liquid drop field. This code has been applied to analyses model flow and heat transfer within the reactor core. This volume describes the finite-volume equations and the numerical solution methods used to solve these equations. This analysis of same parameters has been done i.e.; inlet sub cooling 20 BTU/lbm and 40 BTU/lbm, 1000 psi pressure and R-factor is 1.038, mass flux are 0.5 Mlb/hr.ft<sup>2</sup>, 0.75 Mlb/hr.ft<sup>2</sup>, 1.00 Mlb/hr.ft<sup>2</sup> and 1.25 Mlb/hr.ft<sup>2</sup>. Those conditions based on history operation of some type of the cell fuel bundle line at GE Nuclear Energy. According to the results, it can be concluded that SBWR critical power bundle is 10.5 % less than current BWR critical power bundle with length reduction of 12 ft to 9 ft.*

*Key word: Critical power bundle, SBWR 9 ft length, COBRAG.*

### ABSTRAK

**ANALISIS DAYA KRITIS BUNDEL BAHAN BAKAR SBWR DENGAN PROGRAM COBRAG.** Sistem pendinginan PLTN SBWR memiliki kesamaan dengan PLTN Dodeward yang kritis pertama pada tahun 1968 di Belanda. Kesamaan sistem pendinginan ke dua PLTN tersebut adalah pada sistem pendinginan konveksi alam. Konsep pendinginan alam sangat terkait dan berpengaruh pada parameter-parameter desain bundle bahan bakar khususnya tinggi bundle, penurunan tekanan teras dan laju aliran teras demikian juga daya kritis bundle bahan bakar. Analisis dilakukan dengan menggunakan paket program COBRAG. Paket program COBRAG adalah milik GE yang sudah establish digunakan untuk menyelesaikan masalah termohidrolik teras yang terkait dengan aliran kompresibel tiga dimensi dua arah aliran dan tiga daerah persamaan untuk dua jenis fase aliran air dan uap. Tiga daerah ini adalah pada daerah uap, aliran air kontinyu dan diskontinyu. Program ini digunakan untuk menganalisis model aliran dan perpindahan panas dalam teras reaktor dengan persamaan *finite-volume* yang penyelesaiannya dengan metode numeric. Hasil analisis dari beberapa parameter bundle bahan bakar adalah sebagai berikut: *inlet sub cooling* adalah 20 BTU/lbm dan 40 BTU/lbm, tekanan adalah 1000 psi, dan *R-factor* adalah 1.038, fluks massa adalah 0.5 Mlb/hr.ft<sup>2</sup>, 0.75 Mlb/hr.ft<sup>2</sup>, 1.00 Mlb/hr.ft<sup>2</sup> and 1.25 Mlb/hr.ft<sup>2</sup>. Berdasarkan hasil analisis ini bahwa parameter-parameter tersebut ada kesamaan dengan catatan hasil operasi untuk jenis – jenis bahan bakar yang diproduksi oleh *GE Nuclear Energy* selama ini dan daya kritis

bundle bahan bakar SBWR adalah 10.5 % lebih kecil dari BWR yang sekarang beroperasi yang panjangnya mengalami pengurangan dari 12 ft menjadi 9 ft.

Kata kunci: daya kritis bundle bahan bakar, SBWR panjang bundle bahann bakar 9 ft, COBRAG.

## INTRODUCTION

Indonesia as an archipelago has been experiencing high growth industry and energy demand due to high population growth, dynamic economic activities. The total population is around 230 million people and 54 % to the total population is living in Java. The introduction of Nuclear Power Plant on Java Bali electricity grid will be possible in 2022 for 2 GWe, using proven technology reactor like ABWR or others light water reactor with nominal power 1000 MWe [1,2,3].

US-DOE has offered project to General Electric Nuclear Energy (GE-NE) certification design of Simplified Boiling Water Reactor with nominal power 600 MWe (SBWR-600). This certification project have been done with the International Technical Associated (ITA) which under coordinated by GE-NE. At the same time, the GE-NE also conducted the certification project for Advanced Boiling Water Reactor with nominal power 1350 MWe. Both of the projects are submitted to US-NRC simultaneously. However, the ABWR 1350 MWe has accepted to be certified design by US-NRC and SBWR-600 was postponed.

The natural circulation system has successful operation to apply on BWR-Dodewaard 60 MWe since 1960. However, for ten times's higher power as like SBWR-600 natural circulation should be justified by calculation and measurement. The calculation of critical bundle power was done by COBRAG and GEXL correlation. COBRAG and GEXL correlation are GE proprietary computer code. Both of them are already established to predict for critical bundle power of BWR line fuel type with 12 ft length. But, for the SBWR fuel length is shortened 9 ft is should be determined.

## CALCULATION METHOD

COBRAG and GEXL correlation are GE proprietary computer code COBRAG is the two phase flow model has been extended to encompass multiple fields[1]. In the annular flow regime, the liquid film, vapor and droplet are presented in one set of conservation equation. In the annular flow regime, the liquid film, vapor and droplets are each represented by a set of conservation equation. In sub-cooled boiling, there is a superheated liquid layer which nucleates saturated vapor bubbles at the heated surface, while the bulk liquid is sub-cooled. It is customary to account for the superheated liquid through an energy partition model for the wall heat flux, rather than as a separate field [2- 3]. The sub-channel bundle is presented in the Figure 1.

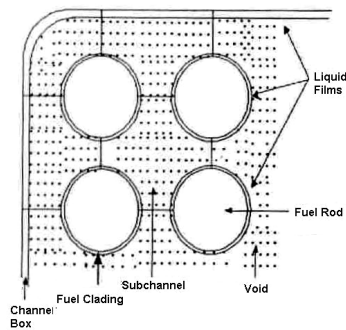

Figure 1. The sub-channel in the fuel bundle

The equations are solved using a staggered-difference scheme where the velocities are obtained at the mesh cell faces and the state variables such as pressure, density, enthalpy, and void fraction are obtained at the cell center. The mesh cell is characterized by its cross-sectional area ( $A$ ), its height ( $Y$ ) and the width of its connection with adjacent mesh cells ( $S$ ). The basic mesh cell is shown in Figure 2.

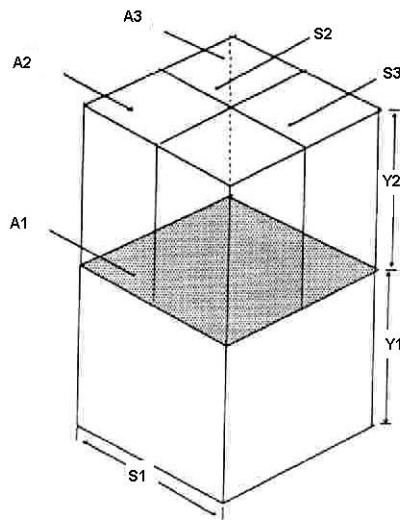

Figure 2 The basic mesh cell

The numerical solution methods are available in the code with a semi-implicit method and an implicit method.

## SUBCHANNEL ANALYSIS

### Sub channel Pattern

Three parameters should be provided by user to preparing sub channel analysis. Three parameters are sub channel pattern, lattice characteristic and gap it self [5,6]. Table 1 are presented the characteristic of sub channel for GE bundle fuel type 8x8 arrays which consist of the 81 sub channel. The average void fraction for each sub channel is 40 %. According to

the surface flow area, volume and local losses can be categorized in 5 type of sub channel. The following five type of sub channel are presented at the Table 1.

Table 1. The characteristic of sub channel

No	Sub channel	Type of sub channel	Total fuel rod	H/U
1	Corner bundle	1	4	Higher
2	Pheripheral channel	2	28	High
3	Fuel rod	3	42	Medium
4	Water rod	4	6	Small
5	Gap between water rod	5	1	Highest

### Lattice Cell Characteristic

Axially, the sub channel are divided in 16 cell and for the each length cell is 0.169333 m except the top position cell is 0.203200 m. Axially cell increment is depend on the total spacer fuel bundle. The spacer position should be allowed with length of cell lattice. The volume of the all cell lattice is  $0.738567E-5 \text{ m}^3$  except the top position cell lattice is  $0.886282E-5 \text{ m}^3$ . The surface area for each cell lattice is presented at the Table 2.

### Gap of Sub channel

The determination of Gap distance base on the distance between cladding of each fuel rods and also between channel fuel boxes. The total of gap type depend on GE fuel type, i.e.; GE8 are 8x8 fuel rod-array, GE11 are 9x9 fuel rods-array and etc. The total of gap type for GE8 is 144 gaps. For each gap are grouping by wide and local losses. Finally, the total gap type is three which presented at Table 2.

Table 2. Lattice cell characteristic

No	Lattice Parameters	Lattice 1	Lattice 2	Lattice 3	Lattice 4	Lattice 5
1	Volume of each channel axially ( $\times 10^{-5} \text{ m}^3$ )	0.738567	0.165605	0.247308	0.222427	0.1975446
2	Surface are of each cell ( $\times 10^{-4} \text{ m}^2$ )	0.436162	0.977983	0.146048	0.131355	0.116661
3	Distance gap of each cell ( $10^{-2} \text{ m}$ )	Gap-1 0.3517990	Gap-2 0.398780	Gap-3 0.261620	N/A	N/A

## RESULT AND DISCUSSION

The result analysis by COBRAG and GEXL correlation for inlet sub cooled 20 BTU/lb and 40 BTU/lb are presented at the Figure 3 Figure 4 respectively. The result analysis of critical power bundle for BWR fuel bundle line with 12 ft length are 10 % higher than SBWR fuel bundle with 9 ft length doe to the peak of cosine power shape for SBWR are higher than BWR-12 ft fuel length. Peak of cosine power shape depend on the cooling system and length of fuel geometry in the reactor core and also the number of fuel spacer.

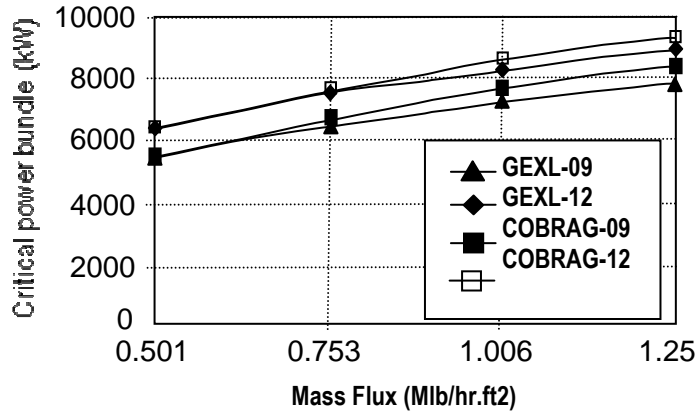

Figure 3. Critical power bundle results for inlet sub cooled 20 BTU/lb

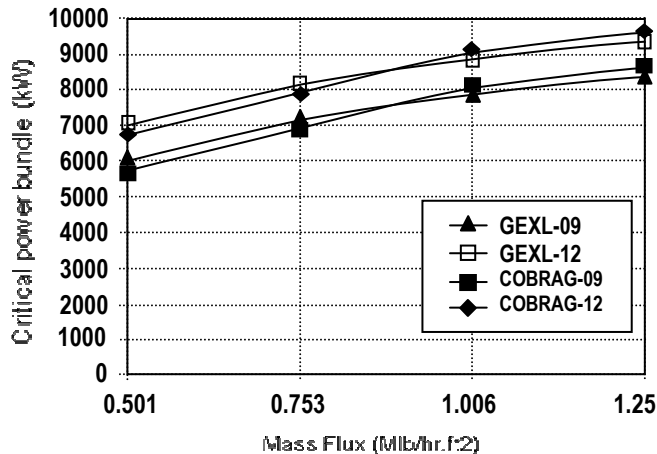

Figure 4. Critical power bundle results for inlet sub cooled 40 BTU/lb

The critical fuel bundle prediction by GEXL correlation and COBRAG are presented at the Figure 5 and 6 respectively. These results are 3 % higher than COBRAG doe to the different method. However, in this case that GEXL correlation can be applied in the prediction of critical power bundle for SBWR-9 ft fuel length. The application of GEXL correlation on critical power bundle prediction is to simplify on the certification process. This prediction can be applied during certification process but for the future licensing i.e.;

construction licensing and commissioning should be measure by full scale facility like ATLAS test facility.

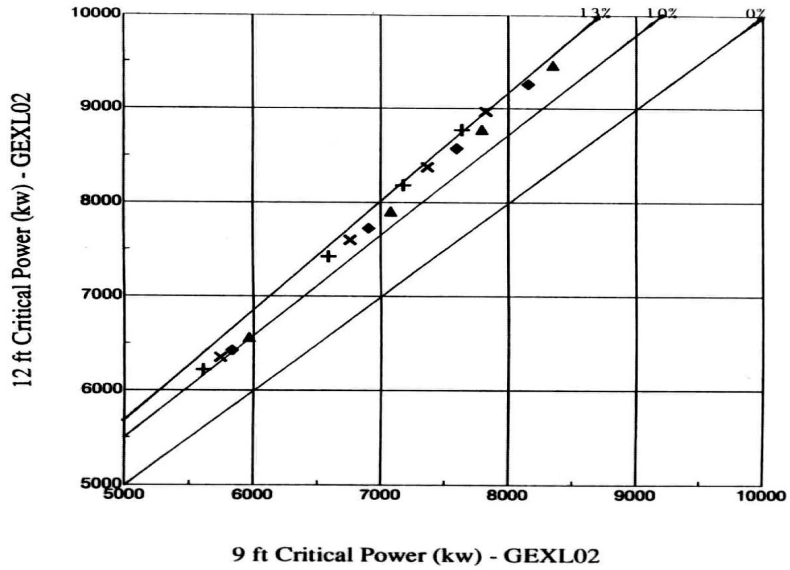

Figure 5. The critical fuel bundle prediction by GEXL correlation

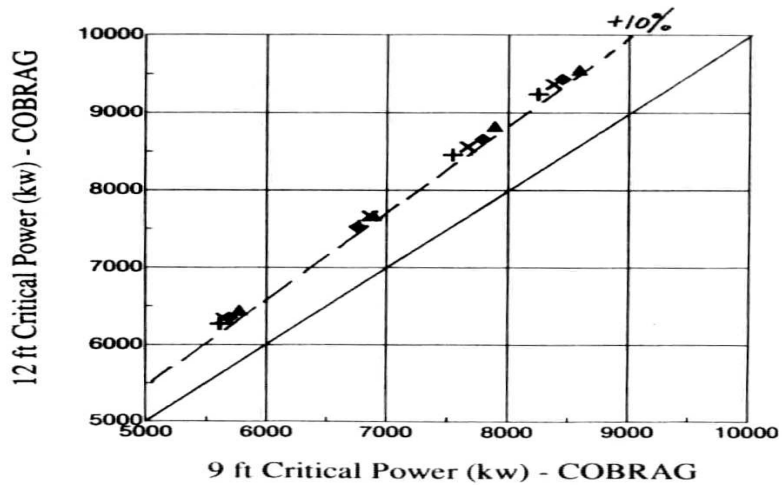

Figure 6. The critical fuel bundle prediction by COBRAG

## **CONCLUSSION**

Eventhough the critical power bundle for SBWR-9ft long test data is not available, COBRAG and GEXL-12ft long corelation can be aplied to predict for critical power bundle of SBWR-600 MWe. The result shows an 10 % average reduction in critical power when bundle length is shortened from 12 ft to 9 ft.

## **ACKNOWLEDGMENTS**

The assistance provided by Dr. Hadid Subki, Dr. K.H. Chu, Mr. Brus Matzner, Dr. H.T. Kim and Dr. S. Simputkar during the course of this study is appreciated.

## **REFERENCES**

1. Indonesia Energy Outlook 2009, Center of Data and Information for Energy and Mineral Resources, Ministry of Energy and Mineral Resources Indonesia, Jakarta 2009.p.5
2. National Energy Policy - Presidential Regulation No. 5/2006, Jakarta 2006.p.4
3. Government Regulation No. 43/2006, Licensing of Nuclear Reactor, Jakarta 2006.p.5
4. S.Pimputkar and B. Matzner, "GE6/8 Fuel Type Critical Power and Pressure Drop Tests," NEDE-30978P, April 1985.
5. M. J. Thurgood, T.L. George, C.L. Wheeler, "COBRAG: A Thermal Hydraulics Code for Transient Analysis," NUREG/CR-3262 –PNL-5515, April 1986.
6. B.S. Shiralkar and K.H. Chu, "Recent Trends In Subchannel Analysis," Subchannel Analysis in Nuclear Reactor, Edited by. H. Ninokata and M. Aritomi, The Institute of Applied Energy (IAE) and Atomic Energy Society Japan, October 1992.