



Area Targeting and Storage Temperature Selection for Heat Recovery Loops

Michael R.W. Walmsley*, Timothy G. Walmsley, Martin J. Atkins,
James R. Neale

Univ. of Waikato, Energy Research Centre, School of Engineering, Hamilton, New Zealand
m.walmsley@waikato.ac.nz

Inter-plant heat integration across a large site can be achieved using a Heat Recovery Loop (HRL). In this paper the relationship between HRL storage temperatures, heating and cooling utility savings (heat recovery) and total HRL exchanger area is investigated. A methodology for designing a HRL based on a ΔT_{\min} approach is compared to three global optimisation approaches where heat exchangers are constrained to have either the same Number of Heat Transfer Units (NTU), Log-Mean Temperature Difference (LMTD) or no constraints (actual global optimum). Analysis is performed using time averaged flow rate and temperature data. Attention is given to understanding the actual temperature driving force of the HRL heat exchangers compared to the apparent driving force as indicated by the composite curves. The cold storage temperature is also varied to minimise the total heat exchanger area. Results for the same heat recovery level show that the ΔT_{\min} approach is effective at minimising total area to within 5% of the unconstrained global optimisation approach. The study also demonstrates the efficiency of the ΔT_{\min} approach to HRL design compared to the other methods which require considerable computational resources.

1. Introduction

Optimising the integration of large industrial sites with many individual plants operating in a non- and semi-continuous manner is a challenging undertaking. Individual plants are first integrated within common operating zones using direct integration methods. Excess heat sources from below a plant's pinch are exported to another plant on the site with a lower pinch temperature with excess sinks. Where plant pinch temperatures are relatively high ($>100\text{ }^{\circ}\text{C}$) waste heat can be used to raise steam and to indirectly transfer heat around the site using a steam belt, which may be connected to the overall site utility system. Where plant pinch temperatures are very low ($<50\text{ }^{\circ}\text{C}$), as in many food and beverage factories, it is uneconomic to raise steam and an alternate approach is to heat liquid water and transport heat around the site using a Heat Recovery Loop (HRL) as illustrated in Figure 1. Selecting the HRL temperatures is important for maximising the heating and cooling utility savings at different times of year (Atkins et al., 2010). Thermal storage, in the form of either multiple tanks or a hot and cold stratified tank, is also needed to facilitate HRL operation and to improve heat recovery in the face of plant disruptions and stream variability (Atkins et al., 2012). Minimising the amount of extra heat exchanger area required for the HRL is another important economic consideration that needs to be evaluated when selecting the HRL storage temperatures and the loop heat capacity flow rate.

In this paper four methods for evaluating HRL heat exchanger area are tested using a six stream example. The relationships between HRL storage temperatures, heating and cooling utility savings

(heat recovery) and total HRL exchanger area for different area distributions are established. A spreadsheet tool based on an area minimisation methodology is used. The tool can be used to evaluate a HRL in the design stage to ensure that heat recovery is maximised at minimum HRL network area.

1.1 Heat recovery loop and indirect heat integration

Heat recovery loops have been considered as a viable indirect heat recovery strategy for batch processes and multi-plant sites for many years (Rodera and Bagajewicz, 1999; Bagajewicz and Rodera, 2000, 2002). Insight based methodologies for selecting the storage temperatures and intermediate fluid flow rates have been developed (Krummenacher and Favrat, 2001). Mixed Integer Linear Programming (MILP) has been applied to improve the integration of batch processes by attempting to optimize the scheduling and Heat Exchanger Network (HEN) design (Chen and Ciou, 2008, 2009). Rigorous optimisation of HRL storage temperatures and heat exchanger total areas, however, is yet to be applied to indirect heat recovery in multi-plant sites across independent semi-continuous processes. The work reported in this paper as an attempt to address this need.

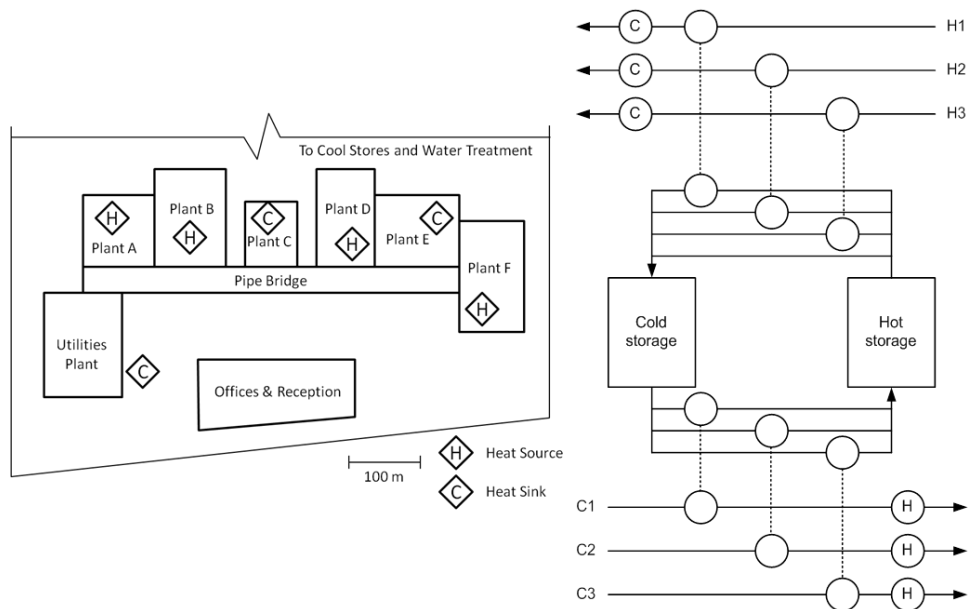

Figure 1: Large multi-plant site and associated Heat Recovery Loop grid diagram

2. Process stream data

Table 1: Inter-plant process stream data

Stream	T_s [°C]	T_t [°C]	CP [kW/°C]	Q [kW]
H1	43	6	7.1	263
H2	70	10	3.5	210
H3	56	18	4.6	175
C1	10	40	5.1	153
C2	12	75	2.3	145
C3	16	55	11.8	460

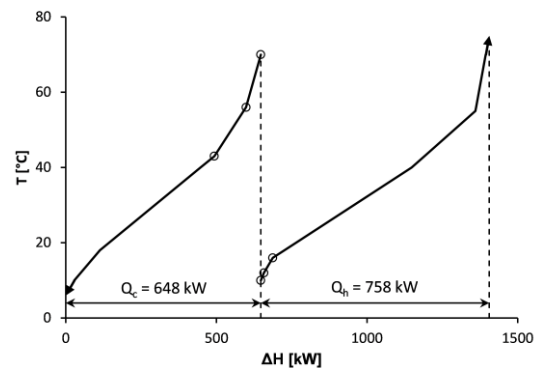

Figure 2: Inter-plant process Composite Curves

The process stream data created to represent streams available for inter-plant indirect heat transfer on a HRL is presented in Table 1. Composite curves show the non-integrated maximum hot and cold utility targets and the locations along the composite curves where streams are supplied in Figure 2. It is assumed that the streams come from processes that act in a semi-continuous manner and that the distance between streams is prohibitive, such that direct integration of the process stream is not possible. The overall heat transfer coefficient, U , of the all exchangers is assumed to be $1 \text{ kWm}^{-2}\text{C}^{-1}$.

3. Methodology

Selection of the optimal storage temperatures and heat exchanger areas are important decisions in HRL design. The methods developed to achieve these objectives are presented in this section.

3.1 Insight based ΔT_{\min} approach

The first method is an extension of traditional pinch analysis using an insight based ΔT_{\min} approach. The composite curves of the available HRL streams are plotted and shifted together until the HRL ΔT_{\min} criterion is met (Figure 3). A line is drawn to represent the HRL between the hot and cold composites of the overlapping region or HRL zone. The two end points represent the feasible temperatures for a two tank HRL system. The slope of this line is the average loop heat capacity flow rate. Pinch points are caused by limiting hot (source) or cold (sink) stream supply temperatures that are within the heat recovery zone and the opposite composite curve (a distance of twice the ΔT_{\min}). This applies for T_h in Figure 3 where the midpoint of the pinch defines the hot storage temperature for maximum energy recovery.

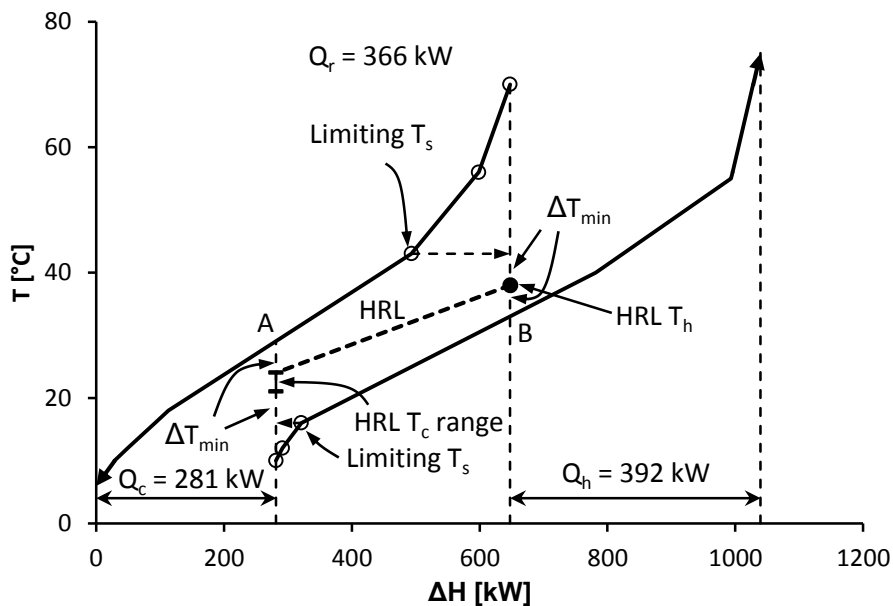

Figure 3: Maximum heat recovery using a ΔT_{\min} approach to targeting a HRL; $\Delta T_{\min} = 5 \text{ }^\circ\text{C}$, $T_h = 38 \text{ }^\circ\text{C}$ and $T_c = 21 \leq T_c \leq 24 \text{ }^\circ\text{C}$

In the case of Figure 3, at the opposite end of the HRL line a range of cold storage temperatures, T_c , exists that still give maximum recovery. The range is constrained by the cold stream C3 supply temperature and the hot composite curve. Points A and B on the composite curves define the required outlet temperature of the process streams for vertical integration and can be used to determine the minimum temperature driving force for heat exchange design. The selection of the cold storage temperature, T_c , provides a degree of freedom that can be used to minimize the total exchanger area.

In other situations the HRL line pinch could be at T_c and the hot storage temperature T_h is free to be optimized over a small temperature range.

Several important design features can be derived from the composite curve; (1) it identifies which streams need to be attached to the HRL, (2) it provides definitive information on the storage temperatures required for achieving maximum heat recovery, (3) it contains the minimum exchanger process stream outlet temperatures required to produce a long-term balanced system (assuming storage capacity is not an issue), and (4) it targets the average utility consumption. ΔT_{\min} can also be varied and the effect on maximum heat recovery, minimum heat exchanger total area and storage temperatures can be evaluated and eventually optimized for minimum cost (which is outside the scope of this paper). In this paper, ΔT_{\min} is varied between 2 – 10 °C and HRL designs, including heat recovery targets (170 – 480 kW), storage temperatures, loop flow rate and heat exchanger areas, are derived from the composite curve.

3.2 Non-linear programming based approach

The second method uses an ExcelTM spreadsheet based non-linear programming technique to find the minimum heat exchanger area and corresponding storage temperatures for a HRL network. The standard non-linear SolverTM that comes with ExcelTM 2010 is used. The HRL storage temperatures and the heat exchanger area are identified as variables with the optimization goal of minimizing the total network area. Logical constraints may then be applied to a specific heat recovery amount and bounds are placed on the search space of the hot and cold storage temperatures. The solver then searches for feasible solutions and determines what is likely to be the global minimum area for the given constraints.

The spreadsheet tool was applied in three ways: (1) all heat exchangers are constrained to have the same Number of Heat Transfer Units (NTU), (2) all heat exchangers have the same Log-Mean Temperature Difference (LMTD), and (3) the area of each heat exchanger is changed independently. The first two constraints are applied to significantly reduce the search space of the solver and to investigate whether or not a different approach to designing a HRL can yield significant benefit by more optimal distribution of area. The third option identifies the global best case for all heat recovery target levels. This provides a reference point for comparing the other three cases studied. A range of heat recovery targets from 170 to 480 kW were modeled for all cases.

4. Results and discussion

4.1 Applying the ΔT_{\min} method to storage temperature selection

The composite curve in Figure 3 contains sufficient information to identify the maximum heat recovery potential, the required hot and cold storage temperatures and the thermal design requirement of the heat exchangers attached to the HRL, for a ΔT_{\min} of 5 °C. As previously explained, Figure 3 was obtained by shifting the composite curves in Figure 2 together until a storage pinch occurred at the hot storage temperature, T_h . Stream H1 supplied at 43 °C is a ΔT_{\min} of 5 °C above T_h at 38 °C. If this ΔT_{\min} was to be violated then stream H1 would need to be removed from the HRL and the composite curves re-drawn and re-shifted. For the two tank HRL system, therefore, the maximum average heat recovery potential is 366 kW.

Other heat recovery targets can be obtained by changing ΔT_{\min} and, therefore, the heat exchanger total area (Figure 4a). With decreasing ΔT_{\min} towards 0 °C the maximum heat recovery occurs is 543 kW. This represents the thermodynamic limit for the stream data using indirect heat exchange with two tanks and infinite heat exchanger area, which is clearly is not economic.

4.2 Heat exchange temperature driving force

The temperature driving forces of the actual heat exchangers on the HRL network are not the same as apparent temperature driving forces determined from the composite curves in Figure 3. This difference is illustrated in Figure 4b. Actual driving forces are taken from the temperature difference between the process stream inlet and HRL fluid outlet. The apparent temperature driving force is the difference in temperature between the composite curve and the HRL line, for the same ΔH value. Redistributing heat exchanger area to better balance temperature driving force may be advantageous in some cases.

However, for this set of stream data the difference is minor, and actual driving forces are similar to the apparent.

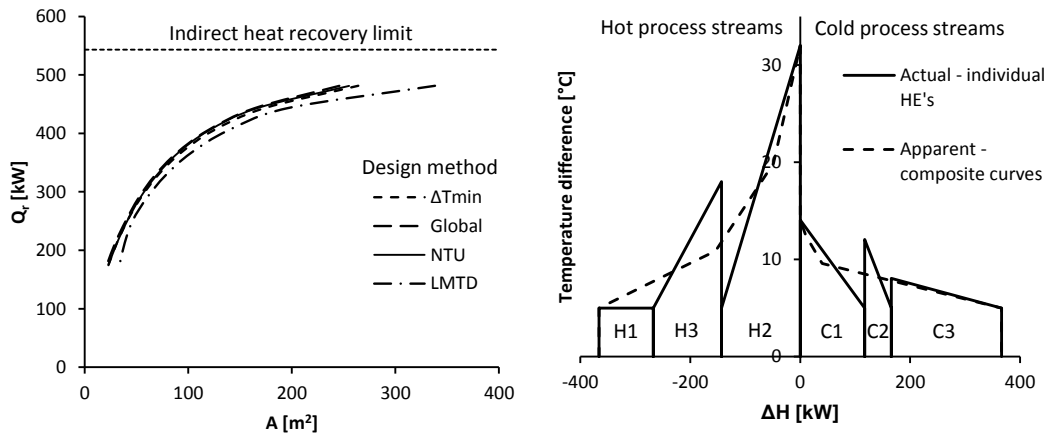

Figure 4: (a) Heat recovery versus heat exchanger total area. (b) A comparison of the apparent (composite curve derived) and actual temperature driving forces for individual Heat Exchangers (HE) in the HRL

4.3 Area distribution in the HRL network

For a ΔT_{min} of 5 °C and a HRL with two storage tanks, the maximum heat recovery is achievable when T_h is 38 °C and T_c is between 21 and 24 °C (Figure 3). In this case the designer has a degree of freedom in T_c that may be applied to optimize the exchanger area without any heat recovery penalty. Figure 5a shows the network area minimization that results from varying T_c . The best cold storage temperature is, therefore, 23.5 °C. The location of the cost optimum may be different to the area minimum due to the inclusion of storage capacity. Residence time and the amount of thermal storage are directly proportional to the temperature difference between the hot and cold storage temperatures. At times it may be beneficial to lower T_c to reduce the size of the storage and pay the penalty in needing more area.

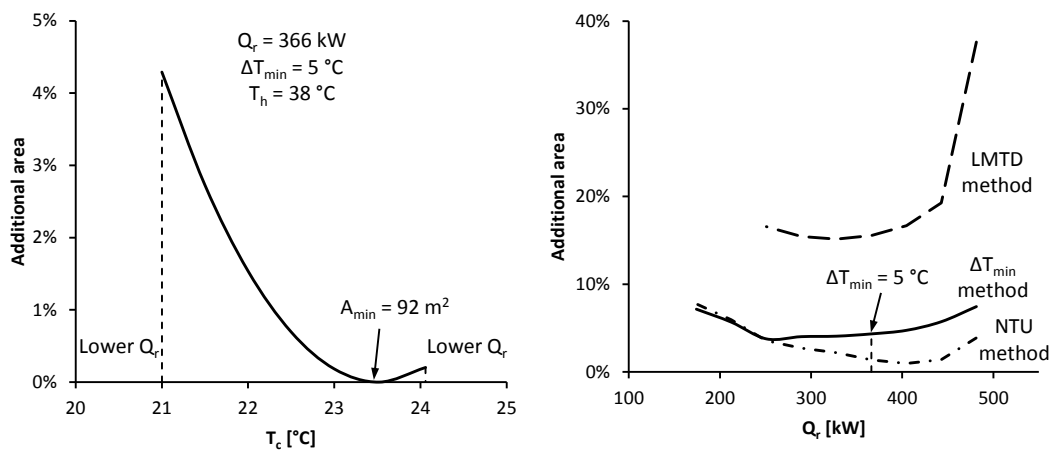

Figure 5: (a) Minimum network area for selection of the cold storage temperature, T_c . (b) Additional area targeted using the ΔT_{min} , NTU and LMTD targeting based methods reference to the global minimum area for a given level of heat recovery

Chapter 2 The unconstrained global optimisation method provides the lowest heat exchanger area options for a given heat recovery target. However, the performance of the insight based ΔT_{\min} method is impressive, being superior to the LMTD method and similar to the NTU method (Figure 5b). On average the relative simple ΔT_{\min} method gets to within 5 % of the global optimisation approach. The three non-linear programming techniques require much greater familiarity with computing techniques and may be taxing on computing resources and time especially when larger problems are to be solve. The NTU and LMTD approaches provide no substantial benefit to minimizing area.

Chapter 3

1. Conclusion

An insight based methodology for designing HRLs using composite curves and the ΔT_{\min} approach has been shown to be comparable to using a global optimisation approach with NTU constraint and superior to using a LMTD constraint. The unconstrained global optimisation approach leads to the lowest area solutions but the method may have computational resource limitations for more complex problems. The actual temperature driving forces in HRL exchangers can differ compared to the apparent driving force predicted from the composite curves. Optimising the selection of the storage temperatures, either hot or cold depending on the situation, is also worthwhile and can result in either reduction of total heat exchanger area or increase heat recovery for the same area. The amount of reduction is again dependent on the specific stream data being considered for the HRL.

References

- Atkins M.J., Walmsley M.R.W., Neale J.R., 2010, The challenge of integrating non-continuous processes – milk powder plant case study. *Journal of Cleaner Production*, 18, 927-934.
- Atkins M.J., Walmsley M.R.W., Neale J.R., 2012, Process integration between individual plants at a large dairy factory by the application of heat recovery loops and transient stream analysis. *Journal of Cleaner Production*, 34, 21-28.
- Bagajewicz M., Roderer H., 2000, Energy savings in the total site heat integration across many plants. *Computers & Chemical Engineering*, 24, 1237-1242.
- Bagajewicz M., Roderer H., 2002. Multiple plant heat integration in a total site. *AIChE Journal*, 48, 2255-2270.
- Chen C.L., Ciou Y.J., 2008, Design and Optimization of Indirect Energy Storage Systems for Batch Process Plants. *Ind. Eng. Chem. Res.*, 47, 4817–4829.
- Chen C.L., Ciou Y.J., 2009, Design of Indirect Heat Recovery Systems with Variable-Temperature Storage for Batch Plants. *Ind. Eng. Chem. Res.*, 48, 4375–4387.
- Krummenacher P., Favrat D., 2001, Indirect and mixed direct-indirect heat integration of batch processes based on Pinch Analysis. *International Journal of Thermodynamics*, 4, 135–143.
- Roderer H., Bagajewicz M.J., 1999, Targeting procedures for energy savings by heat integration across plants. *AIChE Journal*, 45, 1721-1742.