

**Correspondence to:**

Professor W. Henderson,  
Department of Chemistry,  
University of Waikato,  
Private Bag 3105,  
Hamilton,  
New Zealand  
e-mail [w.henderson@waikato.ac.nz](mailto:w.henderson@waikato.ac.nz)  
FAX 0064-7-838-4219

**The cycloauration of pyridine-2-thiocarboxamide ligands**

Kelly J. Kilpin, William Henderson\* and Brian K. Nicholson

*Department of Chemistry, University of Waikato, Private Bag 3105, Hamilton 3240, New Zealand*

## Abstract

Reactions of  $\text{H}[\text{AuCl}_4]$  with *N*-substituted 2-pyridine thiocarboxamide ligands 2- $(\text{C}_5\text{H}_4\text{N})\text{C}(\text{S})\text{NHR}$  ( $\text{R} = p\text{-C}_6\text{H}_4\text{Me}, \text{CH}_2\text{Ph}, \text{Me}, p\text{-C}_6\text{H}_4\text{OMe}$ ) gave cycloaurated derivatives  $\{(\text{C}_5\text{H}_4\text{N})\text{C}(\text{S})\text{NR}\}\text{AuCl}_2$ , with the ligand bonded as the thiol tautomer through the deprotonated SH group and the pyridine N atom to give a five-membered metallacyclic ring. The X-ray structure determination of the  $\text{R} = \text{CH}_2\text{Ph}$  derivative shows a square-planar gold(III) complex that dimerises in the solid state by weak  $\text{Au}\cdots\text{S}$  intermolecular interactions. In contrast, in the reaction of  $\text{H}[\text{AuCl}_4]$  with 2- $(\text{C}_5\text{H}_4\text{N})\text{C}(\text{S})\text{NHR}$  where  $\text{R} = 2\text{-pyridyl}$ , the ligand was oxidised to give a 1,2,4-thiadiazolo[2,3-*a*]pyridinium heterocyclic ring that was crystallographically characterised.

*Keywords:* Gold complexes; Cyclometallated ligands; Thioamide ligands; Sulfur ligands; Crystal structure

## Introduction

As part of studies on cycloaurated gold(III) complexes<sup>1</sup> we are investigating ligands based on deprotonated amide donors, which form a comparable range of complexes to the more traditional cycloaurated complexes with neutral nitrogen and anionic carbon ligands.<sup>2</sup> In this contribution the synthesis and characterisation of *N*-substituted pyridine-2-thiocarboxamide complexes of gold(III) is reported, through direct reaction of the ligands with  $\text{H}[\text{AuCl}_4]$ . The combination of soft sulfur and harder nitrogen donors, with

the potentially oxidising gold(III) centre is of interest, especially since gold(III) dithiocarbamate complexes  $(RR'NCS_2)AuCl_2$  show anticancer activity.<sup>3,4,5,6</sup>

The most attractive preparative method to *N*-substituted 2-pyridine thiocarboxamide ligands  $2-(C_5H_4N)C(S)NHR$  involves the reaction of a primary amine with sulfur in refluxing 2-methylpyridine in the presence of catalytic  $Na_2S \cdot 9H_2O$  (a modified Willgerodt-Kindler reaction).<sup>7</sup> Yields are excellent (>70 %) and the steric and electronic properties of the products are readily tuned by varying the amines used. Such ligands have the potential to coordinate to metal centres in different ways, Scheme 1. Deprotonation of the ligand may occur prior to coordination and because thioamides have two tautomeric forms they may act as either a monoanionic *N, N'* (coordination of thioketo tautomer **1**) or *S, N* (coordination of the thiol form **2**) bidentate ligand. Alternatively, the neutral ligand may coordinate to the metal centre *via* the pyridyl nitrogen and sulfur atoms, **3**. In these cases, five-membered chelates result. However, coordination *via* the amide nitrogen and the sulfur (either as the neutral ligand **4** or after deprotonation **5**) would give four-membered metallacycles. In the case of the deprotonated ligand both tautomeric forms will again be possible but only the thioketo isomer **5** is shown in Scheme 1.

Surprisingly, few *N*-substituted pyridine-2-thiocarboxamide complexes of the platinum group metals or gold appear to have been reported. Palladium(II) complexes have been reported for the three coordination modes that are described in Scheme 1 (Complexes **6a**, **b**, **7a**, **8**, Scheme 2).<sup>8,9,10</sup> Platinum(II) complexes also exist, with the ligand coordinated *via* either the *S, N* (**6c**) or *N, N'* (**7b**) binding modes. One example (**9**) of an *S, N*-coordinated gold(III) complex is reported, synthesised by the extraction of

gold(III) from HCl solution by the ligand. However, structural characterisation by X-ray crystallography was not reported for any of the above complexes, the coordination mode of the ligand being assigned using IR, UV-Vis and NMR spectroscopy. There is one structurally-characterised example of a gold(I) complex, **10**; the thiol tautomer is deprotonated and the ligand is coordinated to the gold through the sulfur atom, with a weak interaction between the gold and the pyridyl nitrogen.<sup>11</sup>

To the best of our knowledge, there are no examples of palladium, platinum or gold four-membered ring systems formed from *N*-substituted pyridine-2-thiocarboxamide ligands, although the Polish literature cites several examples of related four-membered cationic auracycles formed from the coordination of neutral thiocarboxamide ligands (**11a-c**, Scheme 2).<sup>12</sup>

## Results and discussion

### Reaction of *N*-substituted pyridine-2-thiocarboxamide ligands with H[AuCl<sub>4</sub>]

Reactions of ligands **12a-d** with one molar equivalent of H[AuCl<sub>4</sub>] in water gave the cycloaurated compounds **13a-d** in moderate to good yields, Scheme 3. The reactivity of the ligands towards H[AuCl<sub>4</sub>] was dependent on the *N*-substituent; for the methyl derivative (**12a**), the reaction took place rapidly (15 minutes) at room temperature. However, when the *N*-substituent was more electron-withdrawing (*e.g.* **12c** and **12d**) the reaction needed to be refluxed before any reaction was observed. The benzyl substituted ligand **12b** required stirring at room temperature for five hours and any heating of this solution to reflux gave metallic gold. When two equivalents of **12a** were reacted with

H[AuCl<sub>4</sub>] and NH<sub>4</sub>PF<sub>6</sub> the bis(ligand) complex **14** was formed in moderate yields. Complexes **13a-c** were poorly soluble in MeOH, CH<sub>2</sub>Cl<sub>2</sub>, CHCl<sub>3</sub> and acetone; complex **13d**, with a methoxy substituent, was much more soluble in CH<sub>2</sub>Cl<sub>2</sub>, CHCl<sub>3</sub> and acetone. The complexes are soluble in DMSO but decomposition occurred after approximately six hours in solution.

### X-ray crystal structure of **13b**

The structure determination of **13b** confirms that the ligand is coordinated to gold as its deprotonated thiol tautomer, through the sulfur and the pyridyl nitrogen atoms. The remaining two coordination sites on the square-planar gold are occupied by *cis* chloride ligands. The compound crystallised with two independent molecules in the asymmetric unit, which differ mainly in the conformation of the benzyl substituents. The molecular structure and atom labelling scheme of one molecule is shown in Figure 1 and selected bond parameters in Table 1. Excluding the benzyl moiety, the core of the molecule is essentially planar. In molecule 1 the benzyl ring is tilted from the main plane of the molecule at an angle of 18.88(8)°, however in molecule 2 the benzyl phenyl ring is twisted out of the plane of the molecule by 58.80(4)°. The two molecules in the asymmetric unit form dimeric aggregates through weak intermolecular Au...S interactions [3.498 and 3.556 Å (Figure 2)]. While there are many complexes with Au...S interactions involving gold(I), interactions with gold(III) are rather rarer, all having slightly shorter Au...S distances than observed in **13b**. The closest analogues are complexes derived from the cycloaurated 2-phenylpyridine ligand, containing, respectively thiocyanate<sup>13</sup> or chelating dithiolate ligands.<sup>14</sup>

The C(6)-S(1) bond lengths of 1.772(3) Å (molecule 1) and 1.767(3) Å (molecule 2) are longer than the C=S bond length (*ca.* 1.64 Å) in previously characterised *N*-substituted pyridine-2-thiocarboxamide ligands.<sup>15,16</sup> In addition, the C(6)-N(2) bond lengths in **13b** [1.273(3) and 1.278(3) Å for molecules 1 and 2] and are shorter than in the free ligands (*ca.* 1.33 Å). The Au-Cl(1) bonds (*trans* to N) are significantly shorter than the Au-Cl(2) ones (*trans* to S) as expected from their relative *trans* influences.

### Spectroscopic characterisation of cycloaurated complexes **13a – d**

Cycloauration of ligands **12a-d** results in three main NMR spectral changes. Firstly, coordination of the electron-withdrawing gold atom to the pyridyl nitrogen causes a significant downfield shift [CDCl<sub>3</sub> 1.4 ppm; d<sub>6</sub>-DMSO 1 ppm] for the proton adjacent to the nitrogen (H-1, Figure 3). The amide proton is lost upon coordination and not observed in the spectra of the cyclometallated complexes; the H-7 protons change from a doublet in the free ligands **12a** and **12b** to a singlet in the metallacycles **13a** and **13b** as they are no longer coupled to the NH proton (e.g. H-7 in Figure 3). The most obvious change in the <sup>13</sup>C{<sup>1</sup>H} spectra is the signal assigned to the thioketone carbon (C-6), which moves upfield from ~190 ppm in the ligand to ~160 ppm in the metallacycle, resulting from the reduced C-S bond order on coordination.

Characterisation of cycloaurated complexes by infrared spectroscopy is of little use. Other than the loss of the N-H stretch that is present in the ligand the main diagnostic band in the cycloaurated complexes would be in the C-S stretching region. However, the C-S stretch in the region of 600-700 cm<sup>-1</sup> is weak and difficult to assign due to the multitude of other vibrations that occur in this region (e.g. aromatic C-H bending).<sup>17</sup>

Because of the lack of easily ionisable groups on the cycloaurated complexes they gave only weak ESI mass spectra. Minor  $[M+Na]^+$  ions were seen, but the main peaks were from cationic species  $[(L)_2Au]^+$ , analogous to **14**, which were presumably only present in trace amounts, as the samples were pure by NMR and microanalysis. We have previously seen this type of ion in poorly-ionising Au(III) dichloride complexes and found that addition of pyridine to the sample immediately before analysis resulted in substitution of a chloride ligand giving a cationic species which was more visible.<sup>18</sup> However this method was unsuccessful when applied to the cycloaurated complexes **13a – d**; addition of pyridine apparently caused decomposition of the metallacycle.

#### **Reaction of *N*-(2-pyridyl)pyridine-2-thiocarboxamide **15** with $H[AuCl_4]$**

Cycloauration of **15** was investigated as there was the possibility of forming either a five- or six-membered cyclometallated ring with the thioamide acting as an *S,N* donor or an *N,N'*-coordinated five-membered auracycle, Scheme 4. However, when **15** was reacted with one equivalent of  $H[AuCl_4]$ , instead of cycloauration, the ligand was oxidised by the gold followed by internal cyclisation to form a 1,2,4-thiadiazolo[2,3-*a*]pyridinium heterocyclic ring system, with an  $[AuCl_4]^-$  counter ion, **16**. An X-ray crystallographic study gave the molecular structure shown in Figure 4, with selected bond lengths and angles in Table 2.

Crystals of **16** were grown by diffusion of methanol into a DMSO solution of the crude sample. However, microanalysis of the crystals was inconsistent with the X-ray result so the crystal chosen for the diffraction study may not have been representative of

the entire sample. Indeed, the crude yield is also inconsistent with the formulation **16** and it is probable that the cation has crystallised with  $[\text{AuCl}_2]^-$  and  $\text{Cl}^-$  anions as well as  $[\text{AuCl}_4]^-$ , though this was not confirmed.

Few X-ray structural studies have been carried out on 1,2,4-thiadiazolo[2,3-a]pyridine ring systems. Compound **17**<sup>19</sup> and the copper complex **18**<sup>20,21</sup> represent the closest examples of structurally characterised compounds. As with the neutral species **17** and **18**, the cationic moiety of **16** is essentially planar. The C(6)–N(2) bond is 1.293(13) Å, very close to that expected for a C=N bond. The bonds C(5)–C(6), C(7)–N(2) and C(6)–S(1) all have distances which fall between the values expected for either a double or a single bond, suggesting conjugation. The  $[\text{AuCl}_4]^-$  anion has a regular square planar geometry, as expected.

NMR spectroscopy and ESI mass spectrometry are consistent with the X-ray structural analysis. The proton adjacent to the pyridinium nitrogen (H-11) is further downfield (~0.7 ppm) than in the free ligand, however a greater shift (~1 ppm) would be expected if a cycloaurated complex had formed. In addition, the carbon arising from the thioketone group (C-6) has shifted upfield from 188.2 ppm in the ligand to 181.9 ppm in the cation. In the cycloaurated complexes, the corresponding shift is greater (~30 ppm). The ESI mass spectrum shows a single peak at  $m/z$  214.043 which corresponds to the parent cation of **16**.

In hindsight it is not surprising that oxidation and cyclisation of **15** has occurred. Chemical and electrochemical oxidation of *N*-(2-pyridyl)thiocarboxamides has previously been used in the synthesis of 1,2,4-thiadiazolo[2,3-a]pyridinium species. For example, Tabakovič *et al.* have shown that oxidation of **19** at a graphite anode gives the



cation **20**, with the process being reversible either by reduction at a platinum cathode or by reaction with ascorbic acid (Scheme 5).<sup>22</sup> Other oxidants such as nitrosobenzene,<sup>23</sup> sulfonyl chloride<sup>24</sup> and Cu(III) ions<sup>25</sup> have also been shown to oxidise 2-pyridylthioamides to heterocyclic species.

## Conclusions

A series of new gold(III) complexes containing deprotonated pyridine-2-thiocarboxamide ligands have been synthesised and fully characterised, including the X-ray crystal structure of one example, which confirms N,S chelation of the ligand, and the presence of a dimeric motif in the crystal through Au<sup>III</sup>-S interactions. Unlike the more common cycloaurated complexes that contain monoanionic C,N donor ligands these compounds show limited stability, decomposing over a short period of time (approximately six hours in solution), and may be of limited utility as precursors for further investigation of their coordination chemistry. The 2-pyridyl substituted ligand does not undergo analogous cyclometallation but instead the ligand is oxidised and a heterocyclic ring system is formed.

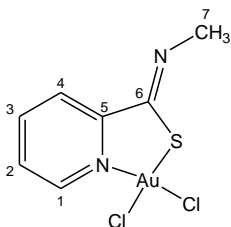
## Experimental

General experimental procedures were as described previously.<sup>2</sup> The *N*-substituted pyridine-2-thiocarboxamides were prepared by the literature method,<sup>7</sup> with their purity assessed by <sup>1</sup>H NMR spectroscopy. H[AuCl<sub>4</sub>].4H<sub>2</sub>O was prepared from gold metal by the literature procedure.<sup>26</sup> High resolution ESI mass spectra were recorded on a

Bruker MicroTOF instrument calibrated using a sodium formate standard; a drop of aqueous NaCl solution was added to the methanolic analyte solution, to promote ionisation through formation of  $[M + Na]^+$  ions. H atoms in NMR spectral assignments are numbered according to the C atom they are bonded to.

### Synthesis of **13a**

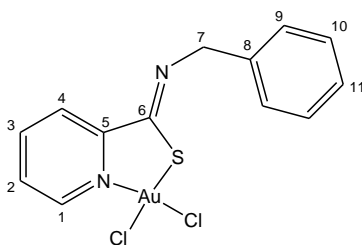
Ligand **12a** (0.200 g, 1.30 mol) and  $H[AuCl_4] \cdot 4H_2O$  (0.536 g, 1.30 mol) were stirred in water (20 mL) for 20 minutes during which time a brown solid formed. The mixture was filtered and the brown solid washed with water ( $2 \times 10$  mL) and isopropanol ( $1 \times 10$  mL) and air dried to give 0.413 g (76%) of **13a**. Found: C 20.4, H 1.9, N 6.4;  $C_7H_7N_2SCl_2Au$  requires C 20.1, H 1.7, N 6.7%. NMR ( $CDCl_3$ ):  $^1H$   $\delta$  3.50 (s, 3H, H-7), 7.75 (ddd,  $^3J_{2,1} = 6.1$  Hz,  $^3J_{2,3} = 7.0$  Hz,  $^4J_{2,4} = 2.1$  Hz, 1H, H-2), 8.19 (ddd,  $^3J_{3,2} = 7.0$  Hz,  $^3J_{3,4} = 8.1$  Hz,  $^4J_{3,1} = 1.4$  Hz, 1H, H-3), 8.23 (dd,  $^3J_{4,3} = 8.1$  Hz,  $^4J_{4,2} = 2.1$  Hz, 1H, H-4), 9.93 (dd,  $^3J_{1,2} = 6.1$  Hz,  $^4J_{1,3} = 1.4$  Hz, 1H, H-1);  $^{13}C\{^1H\}$   $\delta$  40.8 (C-7), 127.0 (C-3), 128.5 (C-2), 142.3 (C-4), 148.3 (C-1), 158.6 (C-5), 162.3 (C-6) ppm. ESI-MS:  $m/z$ : 499.034 (100%,  $[(L)_2Au]^+$ , calc 499.032), 440.930 (78%,  $[M+Na]^+$ , calc 440.927), 418.947 (65%,  $[M+H]^+$ , calc 418.945).



NMR numbering scheme for **13a**

### Synthesis of 13b

Ligand **12b** (0.100 g, 0.44 mmol) and H[AuCl<sub>4</sub>].4H<sub>2</sub>O (0.180 g, 0.44 mmol) were stirred in water (10 mL) for 5.5 hours during which time a pale yellow solid formed. The solution was filtered and the solid washed with water (2 × 10 mL) and isopropanol (1 × 10 mL) and air dried to give 0.107 g (49%) of **13b**. Found: C 31.8, H 2.3, N 5.5; C<sub>13</sub>H<sub>11</sub>N<sub>2</sub>SCl<sub>2</sub>Au requires C 31.5, H 2.2, N 5.7%. NMR (d<sub>6</sub>-DMSO): <sup>1</sup>H δ 4.79 (s, 2H, H-7), 7.31 (d, <sup>3</sup>J<sub>11,10</sub> = 7.4 Hz, 1H, H-11), 7.38 (t, <sup>3</sup>J<sub>10,9/11</sub> = 7.4 Hz, 2H, H-10), 7.47 (d, <sup>3</sup>J<sub>9,10</sub> = 7.4 Hz, 2H, H-9), 8.02 (ddd, <sup>3</sup>J<sub>2,1</sub> = 6.0 Hz, <sup>3</sup>J<sub>2,3</sub> = 7.7 Hz, <sup>4</sup>J<sub>2,4</sub> = 1.7 Hz, 1H, H-2), 8.23 (dd, <sup>3</sup>J<sub>4,3</sub> = 8.0 Hz, <sup>4</sup>J<sub>4,2</sub> = 1.7 Hz, 1H, H-4), 8.41 (ddd, <sup>3</sup>J<sub>3,2</sub> = 7.7 Hz, <sup>3</sup>J<sub>3,4</sub> = 8.0 Hz, <sup>4</sup>J<sub>3,1</sub> = 1.4 Hz, 1H, H-3), 9.66 (dd, <sup>3</sup>J<sub>1,2</sub> = 6.0 Hz, <sup>4</sup>J<sub>1,3</sub> = 1.4 Hz, 1H, H-1); <sup>13</sup>C{<sup>1</sup>H} δ 55.8 (C-7), 126.6 (C-4), 127.0 (C-11), 127.8 (C-9), 128.4(C-10), 129.6 (C-2), 138.6 (C-8), 143.5 (C-3), 148.2 (C-1), 157.1 (C-5), 161.5 (C-6) ppm. ESI-MS: *m/z*: 651.099 (100%, [(L)<sub>2</sub>Au]<sup>+</sup>, calc 651.095), 516.962 (5%, [M+Na]<sup>+</sup>, calc 516.958).

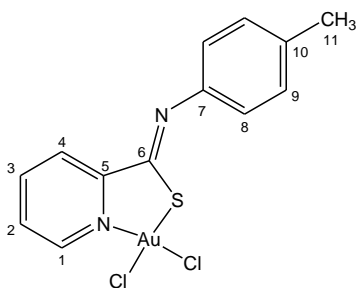


NMR numbering scheme for **13b**

### Synthesis of 13c

Ligand **12c** (0.200 g, 0.88 mmol) and H[AuCl<sub>4</sub>].4H<sub>2</sub>O (0.362 g, 0.88 mmol) were refluxed in water (20 mL) for 1 hour during which time a dark brown solid formed. The solution was filtered and the dark brown solid was washed with water (2 × 10 mL) and

isopropanol (1 × 10 mL) and air dried to give 0.385 g (88%) of **13c**. Found: C 31.9, H 2.2, N 5.6; C<sub>13</sub>H<sub>11</sub>N<sub>2</sub>SCl<sub>2</sub>Au requires C 31.5, H 2.2, N 5.7%. NMR (d<sub>6</sub>-DMSO): <sup>1</sup>H δ 2.34 (s, 3H, H-11), 7.00 (d, <sup>3</sup>J<sub>8,9</sub> = 8.4 Hz, 2H, H-8), 7.29 (d, <sup>3</sup>J<sub>9,8</sub> = 8.4 Hz, 2H, H-9), 8.08 (ddd, <sup>3</sup>J<sub>2,1</sub> = 6.0 Hz, <sup>3</sup>J<sub>2,3</sub> = 7.6 Hz, <sup>4</sup>J<sub>2,4</sub> = 1.4 Hz, 1H, H-2), 8.34 (dd, <sup>3</sup>J<sub>4,3</sub> = 7.9 Hz, <sup>4</sup>J<sub>4,2</sub> = 1.4 Hz, 1H, H-4), 8.48 (ddd, <sup>3</sup>J<sub>3,2</sub> = 7.6 Hz, <sup>3</sup>J<sub>3,4</sub> = 7.9 Hz, <sup>4</sup>J<sub>3,1</sub> = 1.1 Hz, 1H, H-3), 9.69 (dd, <sup>3</sup>J<sub>1,2</sub> = 6.0 Hz, <sup>4</sup>J<sub>1,3</sub> = 1.1 Hz, 1H, H-1); <sup>13</sup>C{<sup>1</sup>H} δ 20.6 (C-11), 120.3 (C-8), 126.7 (C-4), 129.8 (C-9), 130.0 (C-2), 135.6 (C-10), 143.6 (C-3), 144.6 (C-7), 148.5 (C-1), 157.2 (C-5), 161.9 (C-6) ppm. ESI-MS: *m/z* 516.957 (100%, [M+Na]<sup>+</sup>, calc 516.958), 651.095 (49%, [(L)<sub>2</sub>Au]<sup>+</sup>, calc 651.095), 494.971 (14%, [M+H]<sup>+</sup>, calc 494.976).

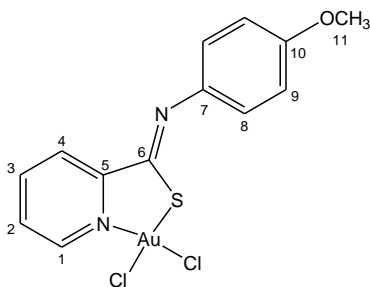


NMR numbering scheme for **13c**

### Synthesis of **13d**

Ligand **12d** (0.100 g, 0.41 mmol) and H[AuCl<sub>4</sub>].4H<sub>2</sub>O (0.169 g, 0.41 mmol) were refluxed in water (15 mL) for 1 hour during which time a dark coloured solid formed. The solution was cooled and filtered and the solid washed with water (2 × 10 mL) and isopropanol (1 × 10 mL). Air drying gave 0.107 g (51%) of **13d** as a dark brown solid. Found: C 29.8, H 2.2, N 5.1; C<sub>13</sub>H<sub>11</sub>N<sub>2</sub>OSCl<sub>2</sub>Au requires C 30.6, H 2.2, N 5.5%. NMR (CDCl<sub>3</sub>): δ 3.85 (s, 3H, H-11), 6.97 (d, <sup>3</sup>J<sub>9,8</sub> = 9.0 Hz, 2H, H-9), 7.22 (d, <sup>3</sup>J<sub>8,9</sub> = 9.0 Hz, 2H, H-8), 7.77 (ddd, <sup>3</sup>J<sub>2,1</sub> = 6.0 Hz, <sup>3</sup>J<sub>2,3</sub> = 7.6 Hz, <sup>4</sup>J<sub>2,4</sub> = 1.6 Hz, 1H, H-2), 8.23 (ddd, <sup>3</sup>J<sub>3,2</sub>

= 7.6 Hz,  $^3J_{3,4} = 8.1$  Hz,  $^4J_{3,1} = 1.3$  Hz, 1H, H-3), 8.43 (dd,  $^3J_{4,3} = 8.1$  Hz,  $^4J_{4,2} = 1.6$  Hz, 1H, H-4), 9.96 (dd,  $^3J_{1,2} = 6.0$  Hz,  $^4J_{1,3} = 1.3$  Hz, 1H, H-1);  $^{13}\text{C}\{^1\text{H}\}$   $\delta$  55.7 (C-11), 114.6 (C-9), 124.1 (C-8), 127.4 (C-4), 128.5 (C-2), 140.4 (C-7), 142.1 (C-3), 148.6 (C-1), 158.4 (C-6), 158.9 (C-10), 159.8 (C-5) ppm. ESI-MS:  $m/z$  683.088 (100%,  $[(\text{L})_2\text{Au}]^+$ , calc 683.084), 532.957 (10%,  $[\text{M}+\text{Na}]^+$ , calc 532.953).

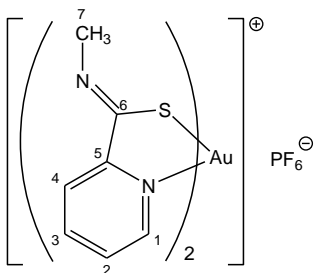


NMR numbering scheme for **13d**

## Synthesis of 14

Ligand **12a** (0.050 g, 0.33 mmol),  $\text{H}[\text{AuCl}_4]\cdot 4\text{H}_2\text{O}$  (0.066 g, 0.16 mmol) and  $\text{NH}_4\text{PF}_6$  (0.054 g, 0.33 mmol) were stirred in water (10 mL) for 20 minutes. The pale brown solid that formed during this time was filtered, washed with water ( $2 \times 10$  mL) and isopropanol (10 mL), and air-dried to give 0.081 g (79%) of **14**. Found: C 25.5, H 2.2, N 8.3;  $\text{C}_{14}\text{H}_{14}\text{N}_4\text{F}_6\text{PS}_2\text{Au}$  requires C 26.1, H 2.2, N 8.7%. NMR ( $d_6$ -DMSO):  $^1\text{H}$   $\delta$  3.56 (s, 3H, H-7), 8.07 (ddd,  $^3J_{2,1} = 5.6$  Hz,  $^3J_{2,3} = 7.6$  Hz,  $^4J_{2,4} = 1.4$  Hz, 1H, H-2), 8.28 (dd,  $^3J_{4,3} = 7.9$  Hz,  $^4J_{4,2} = 1.4$  Hz, 1H, H-4), 8.49 (ddd,  $^3J_{3,2} = 7.6$  Hz,  $^3J_{3,4} = 7.9$  Hz,  $^4J_{3,1} = 1.0$  Hz, 1H, H-3), 8.89 (d,  $^3J_{1,2} = 5.6$  Hz, 1H, H-1);  $^{13}\text{C}\{^1\text{H}\}$   $\delta$  41.2 (C-7), 125.5 (C-4), 129.9 (C-2),

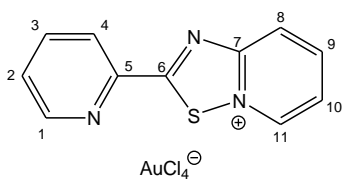
143.5 (C-3), 148.1 (C-1), 154.4 (C-5), 160.7 (C-6) ppm. ESI-MS:  $m/z$  499.033 (100%,  $[(L)_2Au]^+$ , calc 499.032).



NMR numbering scheme for **14**

### Reaction of **15** with $H[AuCl_4]$

Ligand **15** (0.100 g, 0.46 mmol) was stirred in aqueous (15 mL)  $H[AuCl_4] \cdot 4H_2O$  (0.190 g, 0.46 mmol) for 1 hour. The solution was filtered leaving a brown/orange solid that was washed with water ( $2 \times 10$  mL) and isopropanol ( $1 \times 10$  mL) and dried to give 0.144 g of **16**. Found: C 26.8, H 1.8, N 6.9;  $C_{11}H_8N_3SCl_4Au$  requires C 23.9, H 1.5, N 7.6%. NMR ( $d_6$ -DMSO):  $^1H$ :  $\delta$  7.90 (dd,  $^3J_{2,1} = 4.6$  Hz,  $^3J_{2,3} = 7.6$  Hz, 1H, H-2), 8.04 (dd,  $^3J_{10,11} = 6.6$  Hz,  $^3J_{10,9} = 7.4$  Hz, 1H, H-10), 8.28 (dd,  $^3J_{3,2} = 7.6$  Hz,  $^3J_{3,4} = 7.7$  Hz, 1H, H-3), 8.42 (d,  $^3J_{4,3} = 7.7$  Hz, 1H, H-4), 8.60 (dd,  $^3J_{9,10} = 7.4$  Hz,  $^3J_{9,8} = 8.5$  Hz, 1H, H-9), 8.73 (d,  $^3J_{8,9} = 8.5$  Hz, 1H, H-8), 8.88 (d,  $^3J_{1,2} = 4.6$  Hz, 1H, H-1), 9.75 (d,  $^3J_{11,10} = 6.6$  Hz, 1H, H-11);  $^{13}C\{^1H\}$   $\delta$  121.6 (C-4), 122.8 (C-10), 123.2 (C-8), 130.2 (C-2), 138.6 (C-11), 139.6 (C-3), 142.9 (C-9), 146.2 (C-5), 151.0 (C-1), 161.2 (C-7), 181.9 (C-6) ppm. ESI-MS:  $m/z$  214.043 (100%,  $[16-AuCl_4]^+$ , calc 214.043).



NMR numbering scheme for **16**

### X-ray crystal structure determinations of **13b** and **16**

Crystals of **13b** were grown by slow diffusion of diethyl ether into a dichloromethane solution of the compound and **16** was crystallised by slow diffusion of methanol into a solution of the compound in DMSO, both at room temperature. Unit cell dimensions and reflection data for **13b** were collected at the University of Auckland on a Bruker Smart CCD Diffractometer and for **16** at the University of Canterbury on a Bruker Apex II Diffractometer. Semi-empirical absorption corrections were applied by SADABS.<sup>27</sup> Crystal and refinement data for the two complexes are presented in Table 3.

Both structures were solved by Patterson methods of SHELXS-97.<sup>28</sup> The gold atoms were initially located, and all other non-hydrogen atoms were found by a series of difference maps (SHELXL-97<sup>29</sup>) and refined anisotropically. Hydrogen atoms were placed in calculated positions. Because of the pseudo symmetry present in the free pyridyl ring of **16** an inspection of temperature factors was used to assign N(1) and C(4). The pyridyl ring is orientated so that N(1) and S(1) are *cis* to each other. Inversion of C(4) and N(1) (with N(1) and N(2) *cis* to each other) resulted in increases in both  $R_1$  and  $wR_2$ . After a final refinement cycle of **16** there was still a significant amount of residual electron density present. Refinement excluding the high angle data (above  $50^\circ$ ) reduced, but did not totally eliminate, this problem. A peak ( $2.05 \text{ e } \text{\AA}^{-3}$ ) remained approximately  $1.6 \text{ \AA}$

from S(1) and this was assigned as an artefact as it could not be modelled in any chemically sensible way.

### **Supplementary data**

Crystallographic data have been deposited with the Cambridge Crystallographic Data Centre, CCDC Nos. 742305 (**13b**) and 742304 (**16**). Copies of this information can be obtained free of charge from The Director, CCDC, 12 Union Road, Cambridge, CB2 1EZ, UK (fax: +44-1223-336033; e-mail [deposit@ccdc.cam.ac.uk](mailto:deposit@ccdc.cam.ac.uk) or www: <http://www.ccdc.cam.ac.uk> ).

### **Acknowledgements**

We thank the University of Waikato for financial support, Pat Gread with technical maintenance of the electrospray mass spectrometer, and Scott Carter for preparation of the thioamide ligands. KJK thanks The Tertiary Education Commission (Top Achievers Doctoral Scholarship) and the New Zealand Federation of Graduate Women (Merit Award for Doctoral Study). Dr. Tania Groutso (University of Auckland) and Dr. Jan Wikaira (University of Canterbury) are thanked for collection of the X-ray data sets.



**Table 1** Selected structural parameters<sup>†</sup> for **13b** (both molecules), with esds in parentheses.

	Molecule 1	Molecule 2
<i>Bond lengths (Å)</i>		
Au – Cl(1)	2.2709(6)	2.2746(7)
Au – Cl(2)	2.3289(6)	2.3353(6)
Au – S(1)	2.2747(6)	2.2723(6)
Au – N(1)	2.051(2)	2.050(2)
N(1) – C(5)	1.359(3)	1.365(3)
C(5) – C(6)	1.479(3)	1.479(3)
C(6) – S(1)	1.772(3)	1.767(3)
C(6) – N(2)	1.273(3)	1.278(3)
N(2) – C(7)	1.454(3)	1.459(3)
<i>Bond angles (°)</i>		
Cl(1) – Au – Cl(2)	90.58(2)	91.35(2)
Cl(2) – Au – N(1)	95.29(6)	95.45(6)
Cl(1) – Au – S(1)	87.70(2)	86.48(2)
S(1) – Au – N(1)	86.42(6)	86.71(6)
Au – N(1) – C(5)	118.95(16)	118.58(16)
N(1) – C(5) – C(6)	118.1(2)	118.0(2)
C(5) – C(6) – S(1)	117.69(18)	117.98(18)
C(6) – S(1) – Au	98.77(8)	98.59(8)
C(6) – N(2) – C(7)	118.6(2)	117.6(2)

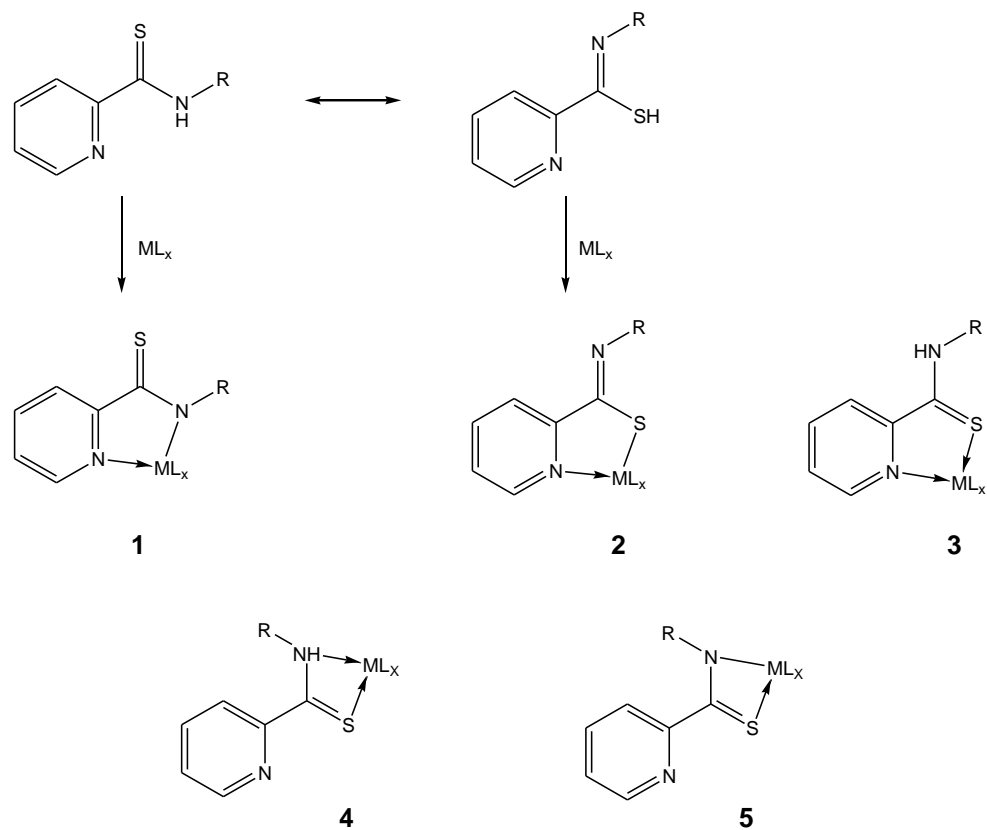
<sup>†</sup>Independent molecules 1 and 2 contain gold atoms Au(1) and Au(2) respectively.

**Table 2** Selected structural parameters for the cation of **16** (esds in parentheses)

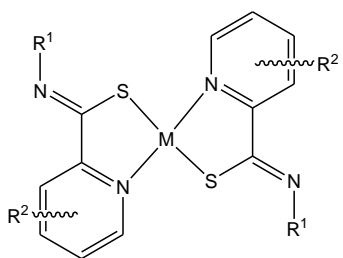
<i>Atoms</i>	<i>Lengths (Å)</i>	<i>Atoms</i>	<i>Angles (°)</i>
N(3) – C(7)	1.378(12)	C(4) – C(5) – C(6)	123.0(9)
C(7) – N(2)	1.376(12)	N(1) – C(5) – C(6)	113.0(9)
N(2) – C(6)	1.293(13)	C(5) – C(6) – S(1)	115.5(7)
C(6) – S(1)	1.727(10)	C(5) – C(6) – N(2)	127.4(9)
S(1) – N(3)	1.704(8)	N(2) – C(6) – S(1)	117.1(8)
C(5) – C(6)	1.462(14)	C(6) – S(1) – N(3)	87.2(4)
		S(1) – N(3) – C(7)	112.3(6)
		N(3) – C(7) – N(2)	113.3(8)
		C(7) – N(2) – C(6)	110.1(8)

**Table 3** Unit cell and crystallographic refinement data for **13b** and **16**

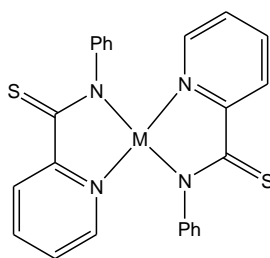
Complex	<b>13b</b>	<b>16</b>
Formula	C <sub>13</sub> H <sub>11</sub> AuCl <sub>2</sub> N <sub>2</sub> S	C <sub>11</sub> H <sub>8</sub> AuCl <sub>4</sub> N <sub>3</sub> S
M <sub>r</sub>	495.16	553.03
T/K	90	90
Crystal system	Triclinic	Monoclinic
Space group	<i>P</i> -1	<i>P</i> 2 <sub>1</sub> / <i>c</i>
<i>a</i> (Å)	7.6029(1)	7.8738(4)
<i>b</i> (Å)	13.6803(2)	28.0459(14)
<i>c</i> (Å)	13.7727(2)	7.2397(4)
<i>α</i> (°)	90.542(1)	90
<i>β</i> (°)	103.635(1)	108.677(3)
<i>γ</i> (°)	91.901(1)	90
<i>V</i> (Å <sup>3</sup> )	1391.14(3)	1514.54(14)
<i>Z</i>	4	4
D <sub>calc</sub> (g cm <sup>-3</sup> )	2.364	2.425
T <sub>max,min</sub>	0.5557, 0.1356	0.1239, 0.0460
Number of unique reflections	6673	2679
Number of observed reflections	5957	2594
[ <i>I</i> >2σ( <i>I</i> )]		
R <sub>1</sub> [ <i>I</i> >2σ( <i>I</i> )]	0.0156	0.0369
wR <sub>2</sub> (all data)	0.0361	0.0910
Goodness of Fit	1.039	1.082



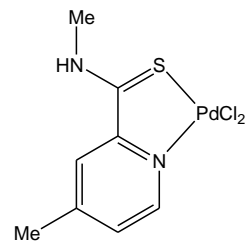
**Scheme 1** Possible bidentate coordination modes of *N*-substituted pyridine-2-thiocarboxamide ligands.



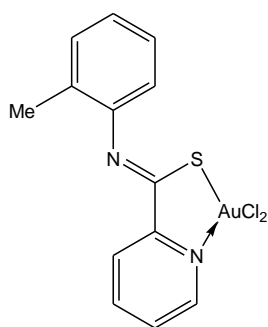
**6a** M=Pd, R<sup>1</sup>=*o*-tolyl, R<sup>2</sup>=H  
**6b** M=Pd, R<sup>1</sup>=Me, R<sup>2</sup>=4-Me  
**6c** M=Pt, R<sup>1</sup>=*o*-tolyl, R<sup>2</sup>=H



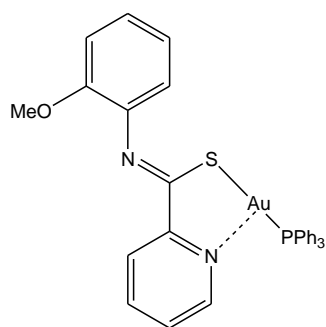
**7a** M=Pd  
**7b** M=Pt



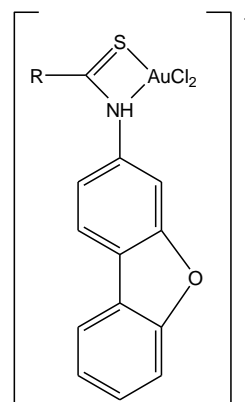
**8**



**9**

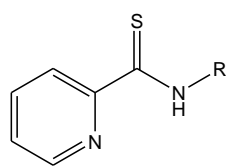


**10**

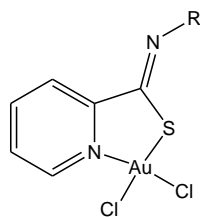


**11a** R=Me  
**11b** R=Ph  
**11c** R=2-furyl

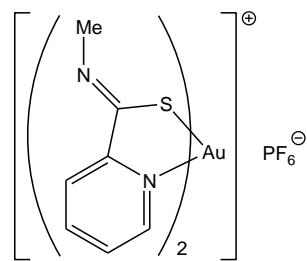
**Scheme 2** Examples of palladium, platinum and gold coordination complexes formed with *N*-substituted pyridine-2-thiocarboxamide ligands.



- 12a** R=Me  
**12b** R=CH<sub>2</sub>Ph  
**12c** R=C<sub>6</sub>H<sub>4</sub>Me-*p*  
**12d** R=C<sub>6</sub>H<sub>4</sub>OMe-*p*

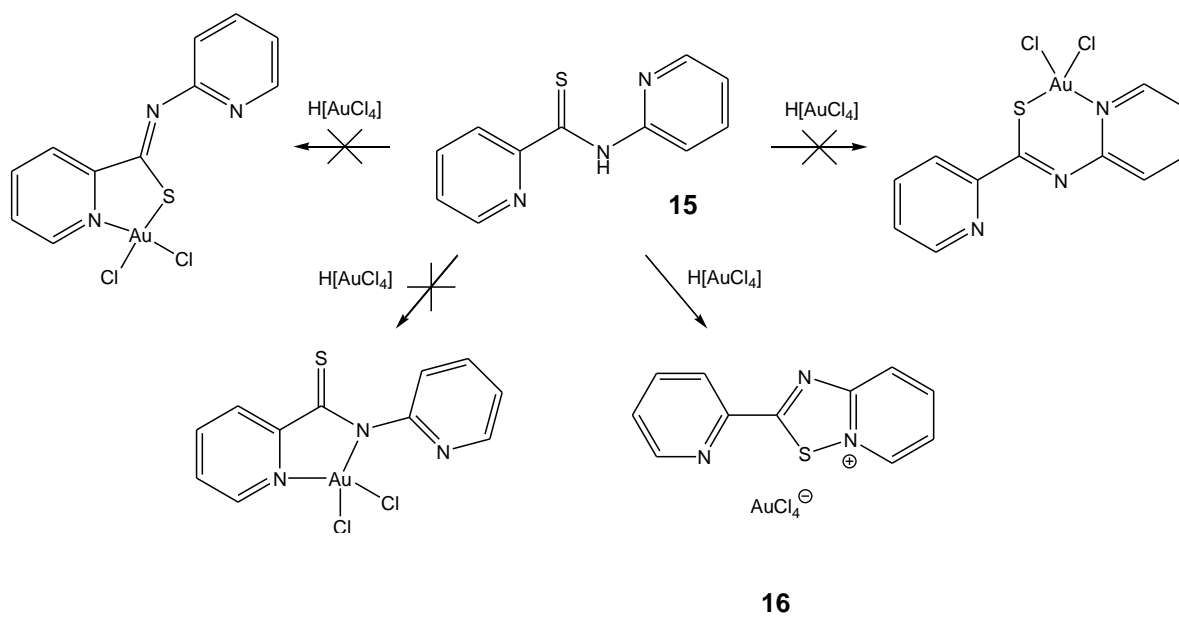


- 13a** R=Me  
**13b** R=CH<sub>2</sub>Ph  
**13c** C<sub>6</sub>H<sub>4</sub>Me-*p*  
**13d** C<sub>6</sub>H<sub>4</sub>OMe-*p*

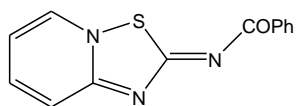


**14**

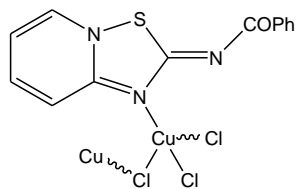
**Scheme 3** *N*-substituted pyridine-2-thiocarboxamide ligands used in this study and the resulting thiocarboxamide complexes formed.



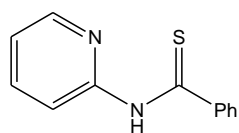
**Scheme 4** Possible reaction products of the ligand **15** with H[AuCl<sub>4</sub>], including the salt **16** obtained by oxidation and ring closure of the ligand



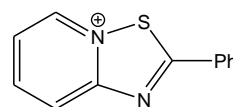
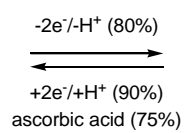
**17**



**18**



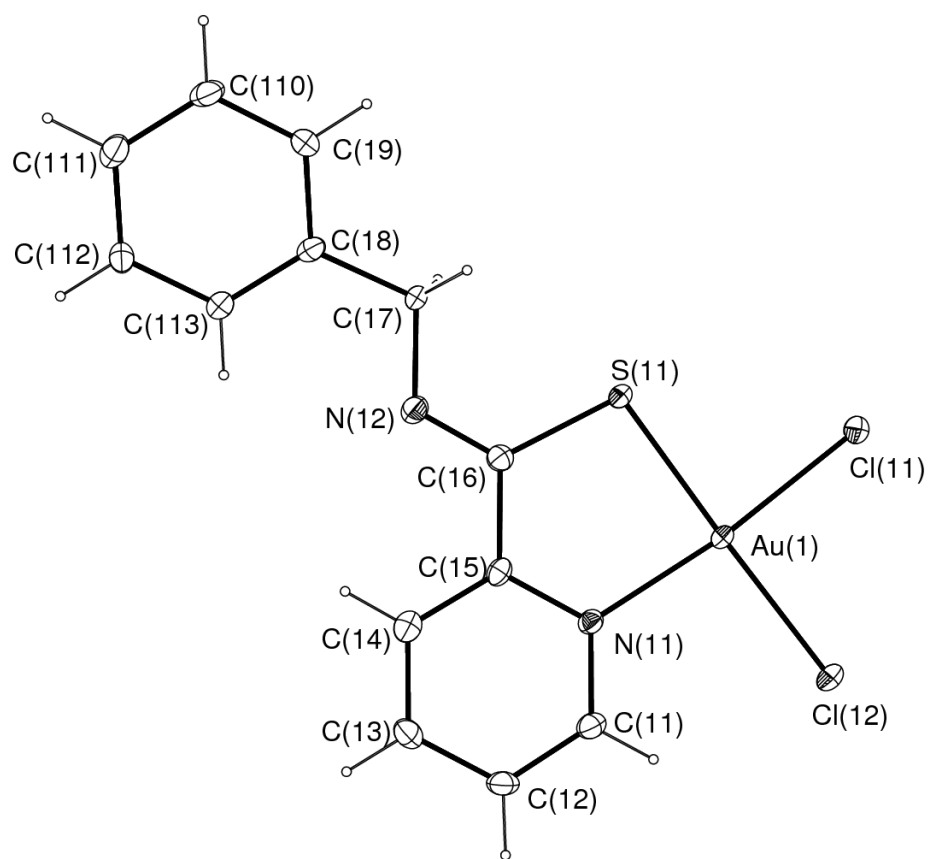
**19**



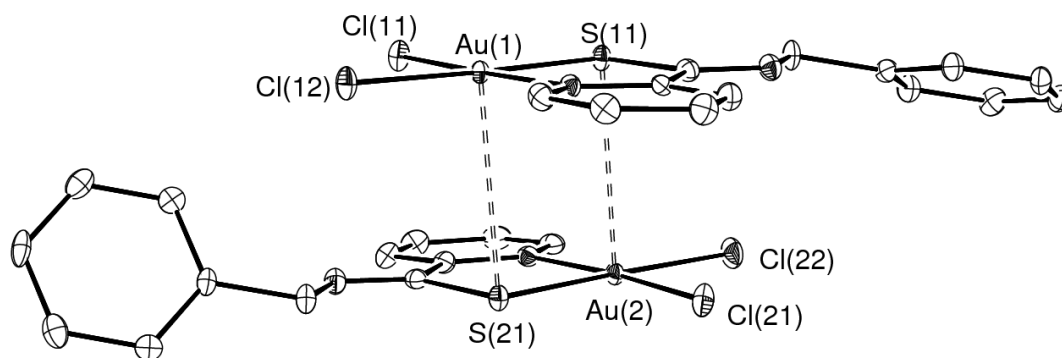
**20**

**Scheme 5** Electrochemical synthesis 1,2,4-thiadiazolo[2,3-a]pyridinium species

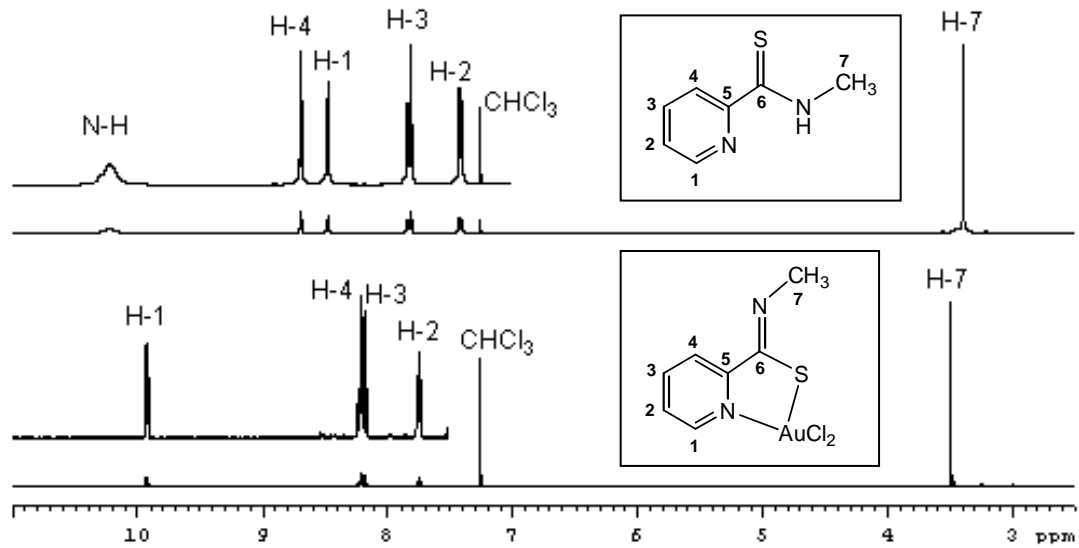




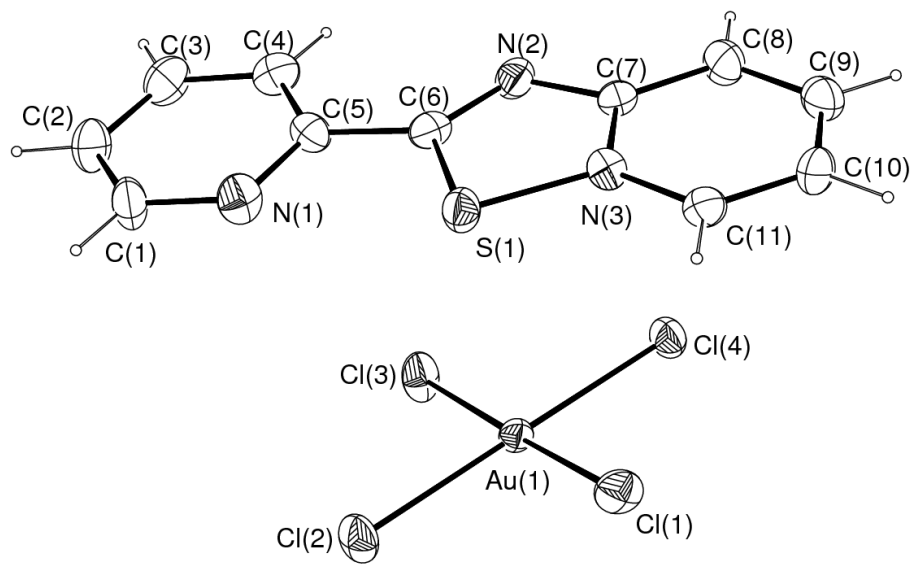
**Figure 1** Molecular structure of **13b** showing one of the unique molecules present in the asymmetric unit, and the atom numbering scheme. Thermal ellipsoids are shown at the 50% probability level.



**Figure 2** Diagram showing the gold-sulfur interactions between the two molecules in the asymmetric unit of **13b**. The different orientations of the phenyl rings can also clearly be seen. Hydrogen atoms have been omitted for clarity and thermal ellipsoids are shown at the 50% probability level.



**Figure 3**  $^1\text{H}$  NMR spectra ( $\text{CDCl}_3$ ) of (a) **12a** and (b) **13a**, showing the changes in the spectra upon coordination of the ligand to gold. The insets show the enlarged aromatic regions (ligand assignment from reference 7).



**Figure 4** Structure of the ionic components of **16** showing the atom labelling scheme. Thermal ellipsoids are shown at the 50% probability level.

## References

---

- [1] W. Henderson, *Adv. Organomet. Chem.* 54 (2006) 207
- [2] K. J. Kilpin, W. Henderson, B. K. Nicholson, *Dalton Trans.* (2008) 3899
- [3] L. Ronconi, C. Marzano, P. Zanello, M. Corsini, G. Miolo, C. Macc, A. Trevisan, D. Fregona, *J. Med. Chem.* 49 (2006) 1648
- [4] L. Giovagnini, L. Ronconi, D. Aldinucci, D. Lorenzon, S. Sitran, D. Fregona, *J. Med. Chem.* 48 (2005) 1588
- [5] L. Ronconi, C. Maccato, D. Barreca, R. Saini, M. Zancato, D. Fregona, *Polyhedron* 24 (2005) 521
- [6] L. Ronconi, L. Giovagnini, C. Marzano, F. Betto, R. Graziani, G. Pilloni, D. Fregona, *Inorg. Chem.* 44 (2005) 1867
- [7] M. H. Klingele, S. Brooker, *Eur. J. Org. Chem.* (2004) 3422
- [8] A. N. Shkil, Y. A. Zolotov, E. G. Rukhadze, *Koordinats. Khim.* 13 (1987) 1352
- [9] E. Gagliardi, H. Zechmann, *Mikrochim. Acta* 2 (1976) 377
- [10] G. Bahr, E. Scholz, *Z. Anorg. Allg. Chem.* 299 (1959) 281
- [11] L. G. Kuz'mina, K. I. Grandberg, L. G. Il'ina, *Zh. Neorg. Khim.* 40 (1995) 1827
- [12] V. Muresan, N. Muresan, A. Resiss, *Pol. J. Chem.* 67 (1993) 2113
- [13] D. Fan, C.-T. Yang, J. D. Ranford, J. J. Vittal, P. F. Lee, *Dalton Trans.* (2003) 3376
- [14] K. Kubo, M. Nakano, H. Tamura, G. Matsubayashi, M. Nakamoto, *J. Organomet. Chem.* 669 (2003) 141
- [15] M. Chen, M. Huang, S. Hu, *Jiegou Huaxue (Chin. J. Struct. Chem.)* 11 (1992) 12
- [16] S. Hu, D. Shi, T. Huang, J. Wan, Z. Huang, *Jiegou Huaxue (Chin. J. Struct. Chem.)* 10 (1991) 110

- 
- [17] R. M. Silverstein, F. X. Webster, *Spectrometric Identification of Organic Compounds (Sixth Edition)*, John Wiley & Sons, Inc., New York (1998)
- [18] W. Henderson, C. Evans, *Inorg. Chim. Acta* 294 (1999) 183
- [19] V. B. Rybakov, L. G. Boboshko, N. I. Burakov, M. Y. Zubritsky, V. I. Kovalenko, V. A. Savelova, A. F. Popov, V. A. Mikhailov, *Kristallografiya* 48 (2003) 627
- [20] D.-J. Che, G. Li, Z. Yu, D.-P. Zou, C.-X. Du, *Inorg. Chem. Comm.* 3 (2000) 537
- [21] G. Li, D.-J. Che, Z.-F. Li, Y. Zhu, D.-P. Zou, *New. J. Chem.* 26 (2002) 1629
- [22] I. Tabakovič, M. Trkovnik, M. Batušič, K. Tabakovič, *Synthesis* 8 (1979) 590
- [23] B. Zaleska, B. Trzewik, E. Stodolak, J. Grochowski, P. Serda, *Synthesis* 18 (2004) 2975
- [24] R. L. N. Harris, *Aust. J. Chem.* 25 (1972) 993
- [25] P. Iliopoulos, K. S. Murray, *J. Chem. Soc., Dalton Trans.* (1988) 433
- [26] *Synthetic Methods of Organometallic and Inorganic Chemistry*, ed. W. A. Herrmann, Thieme, Stuttgart (1999) vol. 5, p. 60
- [27] R. H. Blessing, *Acta Cryst. Sect. A* 51 (1995) 33
- [28] G. M. Sheldrick, *SHELXS-97 - A Program for the Solution of Crystal Structures*, University of Göttingen, Germany, 1997
- [29] G. M. Sheldrick, *SHELXL-97 - A Program for the Refinement of Crystal Structures*, University of Göttingen, Germany, 1997