

**Original citation:**

Papaefstathiou, E., Kerbyson, D. J., Nudd, G. R. and Atherton, T. J. (1995) An introduction to the CHIP3S language for characterising parallel systems in performance studies. University of Warwick. Department of Computer Science. (Department of Computer Science Research Report). (Unpublished) CS-RR-280

Permanent WRAP url:

<http://wrap.warwick.ac.uk/60965>

Copyright and reuse:

The Warwick Research Archive Portal (WRAP) makes this work by researchers of the University of Warwick available open access under the following conditions. Copyright © and all moral rights to the version of the paper presented here belong to the individual author(s) and/or other copyright owners. To the extent reasonable and practicable the material made available in WRAP has been checked for eligibility before being made available.

Copies of full items can be used for personal research or study, educational, or not-for-profit purposes without prior permission or charge. Provided that the authors, title and full bibliographic details are credited, a hyperlink and/or URL is given for the original metadata page and the content is not changed in any way.

A note on versions:

The version presented in WRAP is the published version or, version of record, and may be cited as it appears here. For more information, please contact the WRAP Team at: publications@warwick.ac.uk



<http://wrap.warwick.ac.uk/>

An Introduction to the CHIP³S Language for Characterising Parallel Systems in Performance Studies[†]

E. Papaefstathiou, D.J. Kerbyson, G.R. Nudd, T.J. Atherton

Parallel Systems Group
Department of Computer Science
University of Warwick

Abstract

A characterisation toolset, Characterisation Instrumentation for Performance Prediction of Parallel Systems (CHIP³S), for predicting the performance of parallel systems is presented in this report. In this toolset expert knowledge about the performance evaluation techniques is not required as a prerequisite for the user. Instead a declarative approach to the performance study is taken by describing the application in a way that is both intuitive to the user, but can also be used to obtain performance results. The underlying performance related characterisation models and their evaluation processes are hidden from the user. This document describes the special purpose language, and the evaluation system, that form the core of the CHIP³S toolset. Amongst the aims of the toolset is the support of characterisation model reusability, ease of experimentation, provide different levels of prediction accuracy, and support of different levels of characterisation model abstraction.

1. Introduction

Performance evaluation is an active area of interest especially within the parallel systems community. A large number of performance tools have been developed to assist the system developer, the application programmer, and the tuning expert to select the most efficient combination of hardware and parallelisation strategy [Miller90, Parashar93, Pease91, Reed92]. However, the use of performance tools typically require an advance knowledge of performance related issues, which is usually not commonly understood. The purpose of the characterisation work at Warwick is the development of prediction, and analysis of, methodologies and tools that will allow non performance specialists to undertake performance studies. CHIP³S (Characterisation Instrumentation for Performance Prediction of Parallel Systems) is a set of tools aimed to assist the users to undertake performance studies. In this document a special purpose language and an evaluation system is presented that form the core of the CHIP³S performance toolset.

The notion of performance tools for the "*rest of us*" is the central driving force behind Warwick's characterisation work. In order to achieve this goal, the user of the performance methodology must focus his/her effort on the aspects of the performance study that does not require performance related speciality. The user of performance tools usually knows the application but does not have any knowledge of the performance methodologies. The characterisation toolset presented here requires the user to describe the application that is under investigation in a way that is both intuitive to the user but can also be used in the performance study. The performance related characterisations and their evaluation process, are hidden from the user.

[†] Version 1.50 (January 27, 1995)

The characterisation methodology provides the following features:

- *Characterisation Model Reusability*: Allows the definition of the control flow of the application and the computation/communication pattern in a hardware independent way.
- *Easy Experimentation*: Allows easy experimentation with different hardware platforms and parallelisation strategies.
- *Different Levels of Prediction Accuracy*: Supports different levels of characterisation from high level parametric characterisation (e.g. measuring floating point operations), providing moderate accuracy, to low level instruction level characterisation, providing high accuracy of predictions.
- *Different Levels of Model Abstraction*: Can be used in different stages of software development cycle and different type of software development projects (e.g. serial code porting, parallel software developed from scratch).

The CHIP³S toolset is based on a characterisation framework [Nudd93, Papaefstathiou93, Papaefstathiou94a, Zemerly94]. This framework is a layered approach that separates out the hardware and software systems through the use of a parallelisation template, Figure 1. This modular approach leads to readily re-usable models which can be interchanged in experimentation. For instance the performance predictions across parallelisation techniques can be compared for a particular application on a particular hardware. The layers used are detailed below:

- an application layer, which describes the application in terms of a sequence of sub-tasks using control flow graphs. Each node of the graph can be a sequential processing node, a user defined parallel sub-task, or a parallel processing generic (from a library).
- an application sub-task layer, which describes the sequential part of every sub-task within an application that can be executed in parallel. The result of the evaluation of these models is fed to the parallel template layer.
- a parallelisation template layer, that describes the computation-communication pattern and other hardware resource usage.

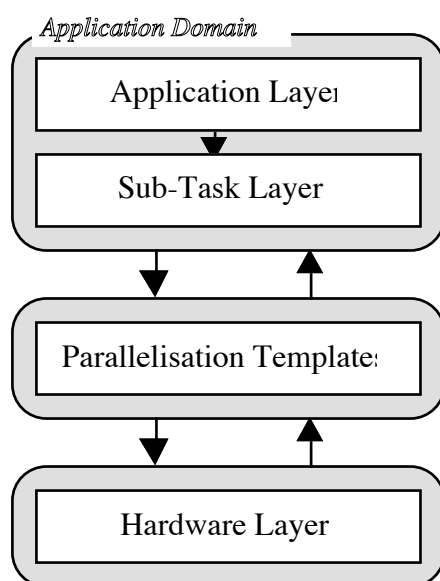

Figure 1 - The Layered Characterisation Framework

- a hardware layer, which is responsible for characterising the communication and computation abilities of the system.

The CHIP³S toolset contains a number of separate programs integrated under a common graphical user interface. The organisation of these components is shown in Figure 2. The main components of this toolset are:

- A set of special purpose language scripts suitable for the description of performance aspects of parallel systems.
- A run-time system that contains an evaluation engine (Mathematica)
- A compiler that translates the scripts into Mathematica source code.

- A set of interface tools which allow the extraction of control flow/resource information from application source code.
- A further set of graphical interface tools that allow the user to define aspects of the performance study and visualise the outputs.

The CHIP³S run-time system is responsible to perform basic maintenance operations such as the loading of CHIP³S compiler output, the evaluation of models, and the storage of the results. The run-time system also includes the evaluation engine that is used to combine and evaluate the models of the performance study. The user will be able to examine the results through a visualisation module and experiment with the performance parameters. A number of pre-defined number of performance analysis studies will be provided such as scalability and bottleneck analysis.

An automated procedure is provided to extract from the user's application the control flow and resource requirements from the user's application. Additionally the resource usage of each node of the control flow graphs is identified in terms of a high level language, or instruction level operations. The resource usage information is combined with the control flow information and converted to CHIP³S language scripts.

The user will be able to edit his/her own CHIP³S language scripts and use the Graphical User Interface (GUI) module to design the computation/communication pattern of the parallel algorithm used, and the control flow of an application that has not yet been developed. After the development of CHIP³S scripts have been concluded for a performance study the CHIP³S compiler will translate the scripts to Mathematica source code.

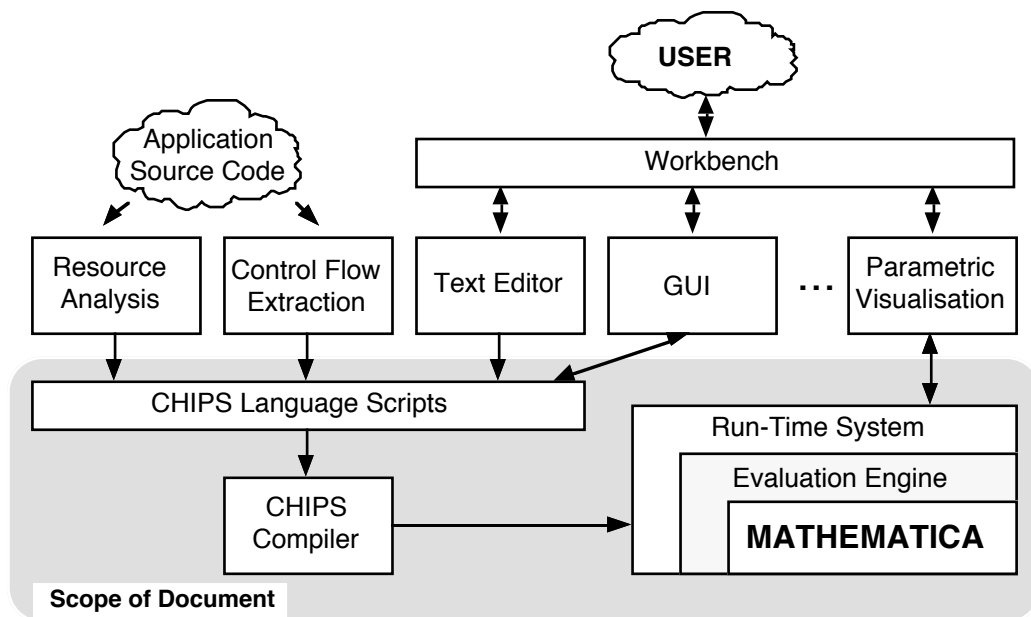

Figure 2 - CHIP³S Tool Organisation

The scope of this document is to present the CHIP³S language, the Mathematica run-time system, and the evaluation engine.

In the next section the main entities (objects) of the CHIP³S language are introduced. There are four types of CHIP³S objects (related to the layered framework): the application, the subtask, the parallel template, and the hardware objects. The main features and the rules govern their interfacing are also explained. In Section 3 the functions of the CHIP³S run-time system are described. In the Section 4 a detailed

language description is presented. The language is presented in BNF format and the semantics of its constructs are explained. In Section 5 an example is given for predicting the performance of a parallel sorting kernel. Finally in Section 6 a summary and a number of extensions that will be included in future versions of the language are described.

2. Objects and Object Interfacing

A program written in the CHIP³S language includes a number of objects. Each object is one of the following types: application, subtask, parallel template, and hardware. These are used to describe the performance aspects of the respective system components. An object is comprised of:

- *Internal Structure*: The internal structure is defined by the programmer and is hidden from the other objects. This structure contains various types of procedures that describe the control flow of the application, the form of any regression models, and computation-communication structures.
- *Options*: The objects, depending on their type, have a number of pre-defined options that determine the default behaviour of the object. The default values of these options can be set in the object, and can be modified by other objects. For example an option might include the default hardware or parallelisation strategy (parallel template) that will be called by a subtask.
- *Interface*: Objects include an interface that can be used by other objects to modify their behaviour. This interface is explicitly defined by the programmer. The interface includes the external variables that can be modified outside of the object scope. The interface might include data dependent, hardware dependent, and other variable types.

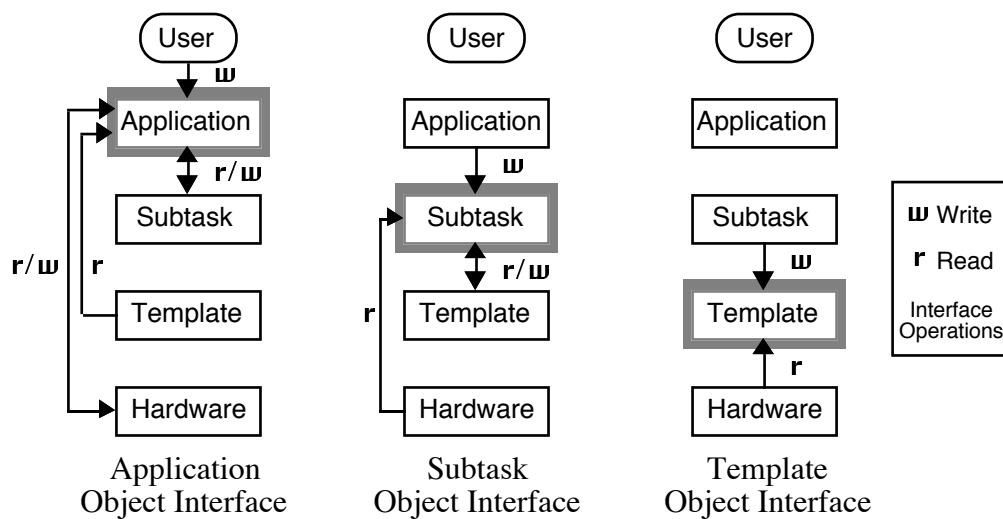

Figure 3 - Object Interfacing

Objects of a certain type can only read from, and write to, certain other object types as shown in Figure 3. An object can read an external variable of other objects only if it is in a lower level of the layered approach hierarchy. Further rules that govern this relationship are described below:

- *Application Type Object*: A CHIP³S program includes only one object of the application type. This is the object that is called automatically from the run-time system of the CHIP³S run-time system (i.e. the entry point of a CHIP³S program).

The external interface of the application object can be used by the user, through the CHIP³S run-time system, to manipulate parameters of the performance study (e.g. change the size of the problem). The application object can modify the external variables of subtask and hardware objects and also use entire subtask objects. For example, a parallel sort application object can use constituent quicksort and bitonic sort subtask objects but only modify the processor configuration of the underlying hardware platform, without directly calling it.

- *Subtask Type Object*: A CHIP³S program might include many subtasks. The interface of a subtask object can be modified by the application object. A subtask can modify the external variables and use template objects. For example the bitonic sort is an object of the subtask type that can be used by the application object, it can modify the external variables and use the bitonic parallel template object.
- *Parallel Template Type Object*: A program might include many parallel template objects. Their interface can be manipulated by subtask objects. The parallel template can not modify the interface of any other object type. The parallel template object describes the computation-communication patterns and the use of other hardware resources.

The definition of hardware objects is not supported directly by the CHIP³S language. The hardware objects must be developed using Mathematica and other analytical or simulation tools. The characteristics and the parameters of a hardware object must be defined in a hardware symbol file. This file is included into the user-defined objects that use hardware parameters.

The CHIP³S environment provides some special purpose objects that have extended semantic features. These include a template with the name *sequential* that covers the case of the execution of a subtask on a single CPU. Also a object called *hardware* will contain a common interface of all hardware platform parameters (e.g. number of processors). This will allow the reference to the hardware objects independently of the type of the parallel system in use. Finally a special case is the symbol file the object *la*, that contains parameters related to the status of the CHIP³S run-time system and evaluation engine. An object by including the *la* symbol file can query the status of CHIP³S.

For each object type a detailed description is given in the following sub-sections below:

2.1 Application Object

A CHIP³S program contains one application object. The object acts as the entry point of the performance study, and includes an interface that can be used by the user through the CHIP³S run-time system to modify parameters of the performance study (e.g. data dependent parameters, hardware platforms to be used). Additionally the application object combines the subtask objects using either control flow graphs or execution procedures. An application object includes the following parts (Figure 4):

- *Include Statement*: Declares the subtask, parallel template, and hardware objects that will be used by the application object.
- *External Variable Definition*: Defines the external variables that will be the interface between the application object and the user through the CHIP³S run-time system. These variables are organised into groups of entities. The interface variables must be either numeric or strings.

- *Linking Statement*: The purpose of the link statement is to modify external variables and options of the subtask objects and the hardware objects being used.
- *Option*: Sets the default options of the application object. These options can be also modified by the user through the CHIP³S run-time system.
- *Procedures*: The procedures describe the relationships of the subtasks in order to predict the performance of any serial parts of the application. This relationship can either be described as control flow graphs (*cflow*) or execution statements (*exec*). Control flow graphs are defined in terms of graph components, whereas execution statements are more flexible allowing complex relationships to be expressed. The application object must include an execution procedure named *init*.. This procedure is the entry point of the program.

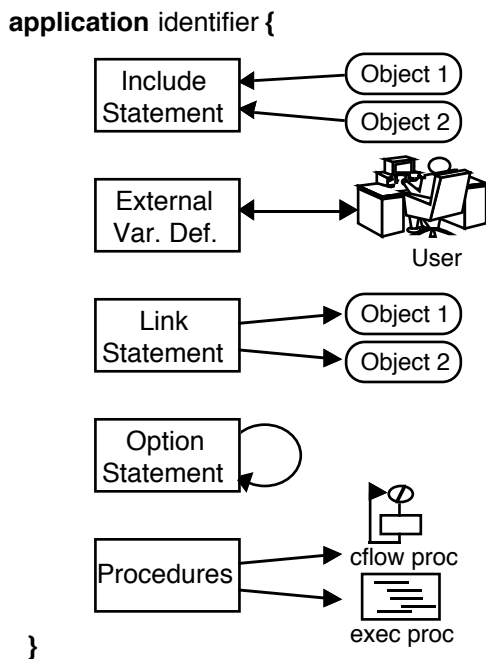

Figure 4 - Application Object Structure

2.2 Subtask Objects

The subtask objects represent parts of an application that are parallelised on a hardware platform using a specific parallelisation strategy. The subtask objects in an application are combined by the single application object.

A subtask object includes the evaluation of the sequential parts of the parallel program. It also includes the mapping of these sequential parts of the application onto the computation-communication pattern described in the parallel template object.

A subtask object can use more than one parallel template object in the case when a part of the application uses more than one parallelisation strategies. This feature gives the flexibility for easy experimentation and selection of the appropriate parallelisation strategy for a hardware platform. During an execution of a CHIP³S program only one template might be evaluated for each subtask.

The subtask object has the same structure as the application object (as shown in Figure 4). The role of the *init* procedure in a subtask object is to specify the execution time of the serial part of the subtask when linked into the parallel template. The presence of the *init* function is optional in the subtask objects. An *init* function might not be required when the serial parts of the subtask are constant and can be specified directly in the link statement.

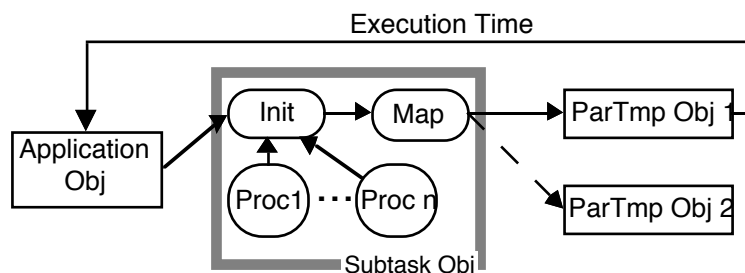

Figure 5 - The Evaluation Process of a Subtask Object

Figure 5 shows the sequence of steps performed during the evaluation of the subtask object. The application object initially uses a subtask object. The *init* procedure of the object is the entry point. The *init* procedure might call other procedures of the object to evaluate the serial parts of the application. These parameters are linked to the currently active parallel template object that was specified by the *option* command in the subtask object or in the application object. Finally, the current parallel template object is called and evaluated. The results of the parallel template object evaluation is the execution time of the subtasks which is returned to the application object.

2.3 Parallel Template Objects

The parallel template object describes the computation-communication pattern and allows access to the hardware devices of a system. The syntax of the parallel template objects is similar to the application and subtask objects with the exception of the statement *link* and the existence of additional statements for *exec* procedures.

The parallel template objects do not manipulate the interface of any of the other objects so there is no need for the existence of the *link* statement. The computation-communication pattern is expressed in terms of stages and steps. A stage is a complete phase of the parallel algorithm and might include many computations and communications. In many cases a parallel template might have many stages of the same computation-communication pattern. In this case there is no need for the re-evaluation of the object for every stage. The number of stages in a parallel template object is defined with the option *nstage*. The method for evaluating the object is defined with the option *seval* (stage evaluation). When *seval* has a value of 0 the object is evaluated only for the first stage and then multiplied by the number of steps to give the overall execution time. When *seval* has the value 1, the object is evaluated once for each stage and the execution time is obtained by accumulating the individual stage execution times. The evaluation procedure is shown in Figure 6.

The parallel template object provides an interface to the resources in the hardware object. When evaluated this allows the application object to specify hardware resource usage. The serial execution time can be calculated in any object with the use of *cflow* procedures. This indirectly involves the hardware models for a single CPU. However, all the other resources including the system inter-connection network, input/output devices, etc., are accessed through the parallel template objects. This is done through the description of the steps of a stage. Each step corresponds to the access to one or more hardware resources, e.g. for computation the CPU, for inter-processor communication the communication network, and for retrieval of data hard disks.

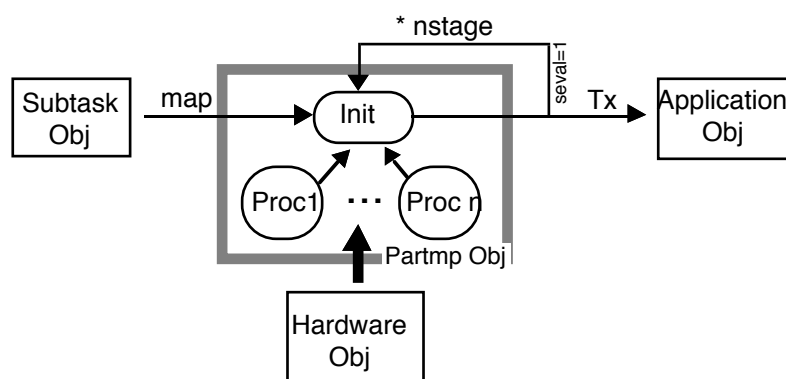

Figure 6 - Parallel Template Evaluation Procedure

Individual steps are defined in *exec* procedures using the command *step* (which is only applicable to parallel template objects). This command defines the hardware resource that will be used and any necessary parameters. By evaluating each step, the CHIP³S run-time system calls the appropriate hardware model and returns the execution time

for the step. The devices that are supported from each hardware platform are included in hardware symbol file. The configuration of each device is done with the command *confdev* . For example, the inter-processor communication network device accepts three configuration parameters. These are: the size of a message, the source processor, and destination processor. This configuration can be repeated many times during the same step in order to describe a complete communication pattern.

3. The Run-Time System

Once the necessary objects have been defined in the CHIP³S program it is compiled using the CHIP³S compiler. The output of this compilation is Mathematica source code. The user can run the Mathematica code from within the CHIP³S run-time system. The run-time system is a shell to the Mathematica language, implemented as a set of Mathematica functions. The aim of this is to simplify and automate various procedures that are performed in order to evaluate the performance model and experiment with the various parameters in the performance study. Also, the run-time system provides utilities to format the output of the evaluation.

There are three types of services provided by the run-time system: execution management , parameter management, and output management. Execution management includes the loading of performance studies into Mathematica, the removal of a performance study from Mathematica, and the evaluation of a performance study. Parameter management allows the browsing of the interface parameters defined in the application object, and the manipulation of their values. The output management permits the selection of the output format for the evaluation, including graphics, and display options. Table 1 lists the Mathematica functions provided by the run-time system (the prefix, *la*, of the Mathematica functions derives from the term Layered Approach).

Name	Type	Description
LaLoad	Execution	Loads into Mathematica the objects of a performance study
LaClear	Execution	Removes the objects of a performance study and initialises the run-time system
LaRun	Execution	Evaluate current application object and return results in a tabular format
LaVarList	Parameter	Lists all variables included in the application object interface including the name, code, and value
LaVarSet	Parameter	Set a variable to take a range of values. The evaluation will produce results for each value of the parameter. The user by setting ranges to many parameters can produce 2D, 3D, and 4D graphs, tables etc.
LaVarClear	Parameter	Cancel a variable range and set a single value
LaVarDef	Parameter	Set default value to a variable
LaVarAllDef	Parameter	Set default values to all variables
LaOutGraph	Output	Display the results in a graph
LaOutAscii	Output	Save the results into an ASCII file
LaOutScr	Output	Display the results on the screen
LaOutNone	Output	Cancel any output

Table 1 - Functions Provided by the Run-Time System

4. Language Description

This section presents the syntax and the semantics of the CHIP³S language. The description includes:

- The definition of the object types, the role of each object and a road-map to the structure of the object (Section 4.1).
- The object header is described in detail (Section 4.2). The statements included in the object header include the interface definition, the setting of parameters of the objects that will be used by the current object and setting of the configuration of the object.
- The control flow procedure syntax is described in Section 4.3. These procedure describe the control flow of a part of an application in terms of a graph notation.
- Then the statement of execution procedures are presented in Section 4.4
- The data representation and manipulation statements are described in Section 4.5.

The syntax of the language is described in BNF form. The non-terminal symbols are presented in *italics* and the terminal symbols in **bold**. A special symbol $\hat{\ }$ is used to denote an empty terminal symbol or the end of a syntax recursion.

4.1 Object Definition

```

application_def      ->   application identifier {
                               include_lst
                               vardef_lst
                               link_stm
                               option_stm
                               proc_lst
                               }

subtask_def         ->   subtask identifier {
                               include_lst
                               vardef_lst
                               link_stm
                               option_stm
                               proc_lst
                               }

partmp_def         ->   partmp identifier {
                               include_lst
                               vardef_lst
                               option_stm
                               proc_list
                               }

```

There are four types of objects representing each layer of the layered approach methodology. Three of them can be defined the CHIP³S language. The user can define, in each performance study, one application object and a number of subtask and parallel template objects.

The purpose of the application object is to provide an entry point for the performance study, to include the interface that can be used in the run-time system by the user, and finally to combine the subtask objects of the performance study using control flow and execution procedures.

The subtask object represents a part of the application that has been parallelised with a specific parallelisation method. The subtask includes the evaluation of the serial parts of the parallel task and the linking of these serial parts onto a parallel template. The subtask might link with more than one parallel templates in cases where the subtask needs to use different parallel algorithms for different hardware platforms or when an experimentation is required to determine the most efficient parallel algorithm. However, during an evaluation of the performance study only one parallel template is used per subtask.

The parallel template object describes the computation-communication pattern of a parallel algorithm. The parallel template might link with one or more hardware platforms. It includes statements to describe the computation communication pattern and to map this to the various communication topologies supported by the hardware object. The syntax of parallel template objects is similar to the other objects. Exceptions are the absence of the *link* statement and the existence of some additional statements in the *exec* procedures. The *link* statement is not used because parallel template objects do not modify the interface of any other type of objects. The additional statements in the *exec* procedures are used to represent the stages and steps of the parallel algorithm and the use of the hardware devices.

CHIP³S language does not support the definition of hardware objects from within the language syntax. The hardware objects must be defined using the Mathematica. Also other types of tools can be incorporated through Mathematica into a hardware object (e.g. simulators, other analytical tools, etc.). The interface of the hardware object must be defined in order for the application, subtask, and parallel templates objects to read and modify hardware parameters.

4.2 Object Header

<i>include_lst</i>	->	<i>include_stm</i> or <i>include_lst include_stm</i> or ,
<i>include_stm</i>	->	include <i>identifier</i> ;
<i>vardef_lst</i>	->	<i>vardef_stm</i> or <i>vardef_lst vardef_stm</i> or ,
<i>vardef_stm</i>	->	var <i>identifier</i> <i>type</i> : <i>var_lst</i> ; or defgroup <i>identifier</i> ;
<i>var_lst</i>	->	<i>var_opt</i> or <i>var_lst</i> , <i>var_opt</i>
<i>var_opt</i>	->	<i>assignment_opt</i> or <i>identifier</i>
<i>type</i>	->	numeric or vector or string
<i>link_stm</i>	->	link { <i>link_body</i> } or ,
<i>link_body</i>	->	<i>link_opt</i> or <i>link_body link_opt</i>

```

link_opt          ->  identifier : assignment_lst

option_stm       ->  option { option_body }

option_body     ->  assignment_lst
                   or  option_body assignment_lst

procedure_lst   ->  procedure_def
                   or  procedure_lst procedure_def
                   or  ,

procedure_def   ->  proc_cflow
                   or  proc_exec

```

The *include* statement is required to declare the use of other objects (for reading or modifying their parameters). The CHIP³S compiler reads the symbol file of the object used as parameter in the *include* command. The symbol file contains the type of the object and the external variables of the object.

The *vardef* statements define the variables before their use. These parameters might be interface variables accessed by other objects, global to the object by hidden by other objects, and locals to procedures. The *var* statement declares the variables that will be used. The declaration includes the group that the variable belongs and their data types. Variables belong to group which depends on the scope and of their function. Three data types are supported by CHIP³S: numeric values, vectors, and strings. The pre-defined groups of variables are:

- *dtdp* the data dependent parameters
- *rsus* resource usage parameters
- *hrddev* the hardware devices available for a specific system
- *scope* variables that external to the procedures of the object but hidden from other objects
- *local* variables that are only accessible in a procedure

The user can also define his own groups with the *defgroup* statement. The grouping of parameters into types is used from the run-time system.

The *link* statement allows an object to modify the interface parameters and options of other objects. This is the method supported by CHIP³S for inter-object communication. The objects that their parameters will be modified should be defined with the *include* statement prior to the *link* statement. The parameters that will be modified must have been defined in the *vardef* statements of the objects. The interface parameter must be of either numeric or strings.

There are a number of rules concerning the type of the objects that can be manipulated. The application object can modify subtask and hardware objects, the subtask object can modify template and hardware objects, and finally the parallel template is not allowed to modify any objects.

The *option* statement allow the setting of the objects configuration. Each object depending on each type have a number of pre-defined options such as the default resource model that will be used, the default hardware platform, the setting of the

debugging mode etc. These options can be also modified by other objects with the *link* statement.

There are two types of procedures supported: the *cflow* and the *exec* procedures. The *cflow* procedures represent the control flow of a piece of software. The compiler evaluates the *cflow* procedures using a graph evaluation algorithm. The output of the *cflow* procedures is an expression that predicts the execution time of the software that the *cflow* procedure represents. The *exec* procedure includes execution statements for looping, branching, etc. which can be run in a similar fashion to a general purpose language code. Execution procedures are included in the CHIP³S language to enable non control flow evaluations to take place.

4.3 Control Flow Procedures

<i>proc_cflow</i>	->	proc cflow <i>identifier</i> <i>argument_lst</i> { <i>locvar_lst</i> <i>cflow_lst</i> }
<i>locvar_lst</i>	->	<i>locvar_opt</i>
	or	<i>locvar_lst</i> <i>locvar_opt</i>
	or	,
<i>locvar_opt</i>	->	var <i>type</i> : <i>var_lst</i> ;
<i>cflow_lst</i>	->	<i>cflow_stm</i>
	or	<i>cflow_lst</i> <i>cflow_stm</i>
	or	,
<i>cflow_stm</i>	->	<i>compute_stm</i>
	or	<i>loop_stm</i>
	or	<i>case_stm</i>
	or	<i>call_stm</i>
<i>compute_stm</i>	->	compute <i>vector</i> ;
<i>loop_stm</i>	->	loop <i>vector</i> , <i>expression</i> { <i>cflow_lst</i> }
<i>call_stm</i>	->	call <i>identifier</i> ;
	or	call <i>identifier</i> (<i>expression_lst</i>) ;
<i>case_stm</i>	->	case <i>vector</i> { <i>case_lst</i> }
<i>case_lst</i>	->	<i>case_opt</i>
	or	<i>case_lst</i> <i>case_opt</i>
<i>case_opt</i>	->	<i>expression</i> : <i>cflow_lst</i>
<i>argument_lst</i>	->	<i>argument_lst</i> , <i>argument_opt</i>
	or	,
<i>argument_opt</i>	->	var <i>identifier_lst</i> ;

The compiler analyses the *cflow* procedures using a graph analysis algorithm and outputs the evaluation expression of the control flow graphs. The procedures return the time required to execution the part of the application represented by the control flow description. The definition of the procedure include an identifier that is the name of the procedure and an optional list of arguments that can be passed from the caller. Arguments are passed by value and can only be numbers.

compound_stm -> { *exec_lst* }

The *exec* procedures include executed statements such as looping, branching, etc. In contrast to the control flow procedures the execution procedure statements are translated directly to the corresponding Mathematica statements. Each object might contain an *exec* procedure *init* that is the entry point of the object. This procedure is called upon any reference to the object that includes it.

The CHIP³S language supports the *while* statement for looping operations. It requires an expression as an argument. This is the condition that as long as it is true the loop is executed. Two related statements are the *break* and the *continue*. These statements are valid when executed inside a loop. The *break* statement terminates the loop independently of the condition of the *while* statement. The *continue* statement causes the next iteration of the enclosing loop to begin.

For conditional branching the *if then else* statement is supported. There is also the *call* statement that is similar to the one used in the control flow functions. However, only *exec* procedures are allowed to be called. Also a procedure might be called implicitly while its name is used in an expression. In this type of call both *cflow* and *exec* procedures can be used.

The *return* statement determines the end of the execution of the current procedures and the *return* of the execution of the procedure that has called the current executing procedure. If *return* includes an expression argument the results of the expression if returned to the caller procedure. The *exit* command terminates the execution of the performance study and returns control to the CHIP³S run-time system.

The *dim* and *free* statements provide dynamic vector allocation support. The *dim* statement creates a data vector (not a resource usage vector). The first argument is the name of the vector and the second the size of the vector. The *free* statement de-allocates the vector. Additionally assignment and *print* statement are supported.

The *step* and *confdev* statements are applicable only in parallel template objects. Each pattern might contain more than one stage and each stage more than one step. Each step corresponds to the use of one of the hardware resources of the system. The argument in the *step* command is the name of the device that will be used during the step. The available devices of the current hardware platform are listed in the hardware symbol file that is used with the *include* statement in the beginning of the object definition. The devices that have been defined in this symbol file have the type *hrddev*. The code body of the *step* statement is to configure the device specified in the current step.

A *step* statement must not include other embedded *step* statements. The configuration of the device is performed with the *confdev* statement. The arguments of this statement is a list of expressions. The meaning of these arguments depend on the device. For example the device *cpu* accepts only one argument which is the execution time of a processing stage. The device *inpcom* (inter-processor communication) accepts three arguments the message size, the source, and the destination processors. The *confdev* statement in the case of the *inpcom* device can be used many times to describe a complete communication pattern. Other hardware devices might include access to a storage device or communication between parallel systems across HiPPi networks etc.

4.5 Data Representation and Manipulation

assignment_stm -> *assignment_opt* ;

<i>assignment_opt</i>	->	<i>identifier = expression</i> or <i>identifier = vector_const</i> or <i>identifier = string_const</i>
<i>expression_lst</i>	->	<i>expression_opt</i> or <i>expression_lst , expression_opt</i>
<i>expression_opt</i>	->	<i>expression</i> or <i>string_const</i> or '
<i>expression</i>	->	<i>expression + expression</i> or <i>expression - expression</i> or <i>expression * expression</i> or <i>expression / expression</i> or <i>expression > expression</i> or <i>expression >= expression</i> or <i>expression < expression</i> or <i>expression <= expression</i> or <i>expression == expression</i> or <i>expression != expression</i> or <i>- expression</i> or <i>+ expression</i> or <i>(expression)</i> or <i>variable</i> or <i>identifier (expression_lst)</i> or <i>identifier()</i> or <i>number</i>
<i>variable</i>	->	<i>identifier</i> or <i>identifier [expression]</i> or <i>identifier. identifier</i>
<i>vector</i>	->	<i>vector_const</i> or <i>identifier</i>
<i>vector_const</i>	->	< is identifier , expression_lst > or < 0 >
<i>string_const</i>	->	" <i>string_char</i> "

The language supports three data types: numeric, one dimensional vectors, and strings. These can be represented either as constants or variables. Variables must be declared before used, by the *var* statement. The scope of the variable might be externally visible to other objects, external in the object but hidden from other objects, and finally local to a procedure. The attributes of the variable is again determined with the *var* statement.

A vector can be of type data or as resource usage. This attribute is defined as the first parameter in the vector definition using the *is* statement. If the argument in the *is* statement is *data* the vector is handled as data, otherwise it is handled as a resource usage vector. In this case the type of the resource usage is defined as the identifier that follows the *is* statement. Dynamically supported vectors are supported with the *dim* and *free* statements.

CHIP³S provides a dynamic approach for defining the type of vectors. The user has the ability to define additional vector types by specifying the type of the vector and the

elements that can be included. This definition is done by an additional tool, the vector definition tool (*vctdef*), that converts the user definition to a vector specification file that is used by the CHIP³S compiler during the compilation stage. Attributes of a vector type are the number of elements of the vector. A vector can have either a fixed or variable number of elements. Each element can be a number, a symbol, or a combination of both. An example definition of the *data* vectors in tool follows:

```
(* Array numeric vector *)
def data {
    args variable;
    type numeric;
}
```

An example definition of a resource usage vector for floating point operations can be defined as follows:

```
(* Floating point operation resource usage vector *)
def flop {
    args variable;
    type combination;
    { add, sub, mul, cmp, div, sqr, exp, sin, other }
}
```

The *flop* vector has a variable number of elements but its element might be an expression that includes numeric values and/or symbols. The symbols are defined as the type of floating point operation (add, subtraction, etc.).

The expressions can only include numeric values. The expressions support the +, -, *, / arithmetic operations, >, <, =>, <=, ==, != conditional operators, unary -, the call of *cflow*, *exec*, or pre-define mathematical procedure, the reference to any numeric variable.

A variable can be an identifier referring to a local to the object variable, an element of a data vector, and an external to the object variable. In this case the scope must be defined first and then, separated with a dot, the name of the parameter must be identified. The string constants and variables can be only used for output purposes.

4.6 Miscellaneous

assignment_lst -> *assignment*
 or *assignment_lst , assignment*
 or ,

vector -> *identifier*
 or *vector_const*

identifier, *string_char*, *number* are defined in the lexical analyser

5. An Example of Characterising a Sorting Kernel

An example of using the CHIP³S language to develop a characterisation performance model is shown below. The application under consideration is a sorting kernel based on the Batcher's bitonic sort. The kernel developed for a transputer based Parsytec SuperCluster. There are a number of phases for the execution of this kernel:

- **Data Load:** A number of data elements are stored on the hard disk of the host workstation. Part of the data is loaded into the memory of each transputer.
- **Serial Sorting:** The data elements in the local memory of each processor are initially sorted using a serial sorting algorithm, which in this case is quicksort.
- **Merging:** The sorted data elements on each processor are merged with the bitonic algorithm in order to create an overall sort list.
- **Data Store:** The sorted array is stored onto the hard disk of the host workstation.

For this example only the merging part of the sort is considered. The CHIP³S program consists of: an application object *memsort*, that combines the serial sort with the merge procedures; the serial subtask object *qsort* (that is not presented here); the subtask object *merge* that uses the bitonic parallelisation strategy; and the parallel template object *bitonic*. The example illustrates the use and interfaces between objects of all types. It is not intended to provide the results of a performance study. The source code of the application object is described first:

Application Object

```

1  (* memsort.la: Parallel memory sort application *)
2
3  application memsort {
4
5      include qsort;          (* Qsort Subtask *)
6      include merge;        (* Merge Subtask *)
7      include hardware;     (* Hardware Parameters *)
8
9      (* Interface Variables Accessable by the User *)
10     var dtdp numeric:
11         Nelem = 262144, (* Elements to be sorted *)
12         Nsize = 4;     (* Size of element (bytes) *)
13     var sysd numeric:
14         Nproc = 16;   (* Number of processors *)
15
16     link {
17     hardware:
18         Nproc = Nproc;
19     qsort:
20         Nelem = Nelem / Nproc;
21         Method = 1;
22     sort:
23         Nelem = Nelem;
24         Nsize = Nsize;
25     }
26
27     (* Init - Entry point for performance study *)
28     proc exec init {
29         return qsort + merge;
30     }

```

```

31
32 } (* End of application *)

```

The application object, *memsort*, begins with its name definition in line 3, followed by the object header (lines 5-25), and finally the main body (lines 26-32).

Initially the objects used are defined in lines 5-7 with the *include* statement (the *memsort* object uses the subtask objects *qsort* and *merge* and the generic hardware object).

The definition of the parameters that can be modified by the user through the CHIP³S run time system follows in lines 9-14. These are the number of elements to be sorted (*Nelem*), the size of each elements in bytes (*Nsize*), and the number of processors (*Nproc*). *Nelem* and *Nsize* have been specified as data depended parameters (*dtdp*) and *Nproc* as system depended parameter (*sysd*). The modification of parameters in the other objects being used is specified in lines 16-25 (using the *link* statement). Initially (lines 17-18) the hardware object parameter *Nproc* is set to the number of processors. It should be noted that the parameter *Nproc* has the same name in both the application and the hardware objects. However, there is no scope conflict since the parameter on the left of the assignment belongs to the hardware object and the parameter on the right belongs to the application object. Similarly the parameters are set for the *qsort* and the *merge* subtask objects (lines 19-24).

The last part of the object is the *init* execution procedure. This is the entry point of the object (and the performance study as a whole). In this case, it only includes a statement then returns the accumulated execution times of the *qsort* and *merge* objects.

Subtask Object (merge)

```

1  (*
2  * merge.la: Parallel bitonic sorting
3  *)
4
5  subtask merge {
6      include bitonic;           (* Bitonic template *)
7      include sequential;       (* Sequential template *)
8      include hardware;         (* Hardware Parameters *)
9
10     (* Interface variables *)
11     var dtdp numeric:
12         Nelem = 4096,          (* Elements to be sorted *)
13         Nsize = 4,            (* Size of element *)
14         Pmrg0 = 0.639,        (* Merge reg.model parameter *)
15         Pmrg1 = 0.793;        (* Merge reg.model parameter *)
16
17     (* Static variables *)
18     var scope numeric:
19         dtpp,                  (* Data per processor *)
20         Pmrg;                  (* Merge probability *)
21
22     (*
23     * Link to templates
24     *)
25     link {
26     bitonic:
27         Ndata = dtpp;
28         Clen  = Nsize;
29         Tx    = Txsort();
30     sequential:
31         Tx    = 0;
32     }

```

```

33
34      (*
35      * Entry point procedure
36      *)
37      proc exec init {
38          (* Calc data per processor *)
39          dtpp = Nelem/hardware.Nproc;
40          (* Regression model merging probability *)
41          Pmrg = Pmrg0 + Pmrg1 / hardware.Nproc;
42      }
43
44      (*
45      * Main seg for merge function
46      *)
47      proc cflow Txsort {
48          var vector:
49              start = <is hllc, 3*IASG>, (* Initialisation *)
50              merge = <is icc, 169, 20>, (* Merge loop *)
51              tlcp = <is time, 6.03>, (* Copy after merge *)
52              otcp = <is hllc, FOR, IASG, ICMP, 2*IADD,
53                  4*VIDX, 2*FASG>;      (* Output array copy *)
54
55          compute start;
56          loop <0>, 2*dtpp*Pmrg {
57              compute merge;
58          }
59          loop <0>, 2*dtpp*(1-Pmrg) {
60              compute tlcp;
61          }
62          loop <0> dtpp {
63              compute otcp;
64          }
65      }
66  } (* End of subtask *)

```

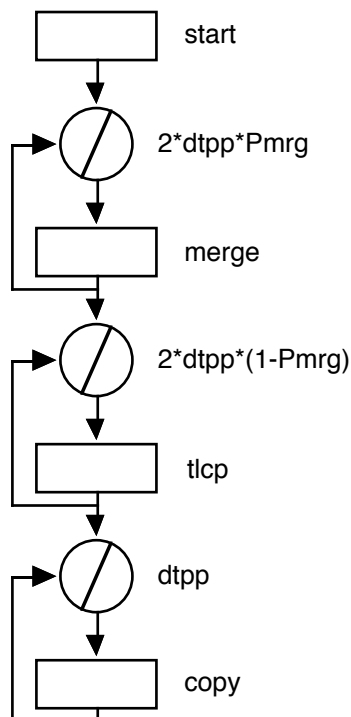

Figure 7- Control Flow
Graph for Merge

The source code of the *merge* object begins with the subtask name definition (line 5) and continues with the object header (lines 6-32), and the procedures *init* and *Txsort* (lines 37-65). The execution time for the merging is calculated by the control flow procedure *Txsort*.

Initially the use of the *bitonic* parallel template object, the *sequential* parallel template object, and the generic hardware object (lines 6-8) are declared. The *sequential* object is a special purpose object that covers the case of a subtask to be executed serially in only one processor. The interface parameters are defined in lines 10-15. These are: the number of elements to be sorted (*Nelem*), the size of each element (*Nsize*), and two regression model parameters to calculate probabilities for the merge software execution graph in the *Txsort* procedure (*Pmrg0*, *Pmrg1*). The variables used as global variables within the object (but hidden to the other objects) are defined in lines 18-20. The parameters for the objects *bitonic* and *sequential*. are set in lines 25-26. For the *bitonic* object the number of elements (*Ndata*), the size of each element (*Clen*), and the execution time required for each merge (*Tx*) are set.

The *init* procedure (lines 37-42) calculates two execution

parameters, *dtp* (data elements per processor) and *Pmrg* (the probability for the merge loop to be finished in the *Txsort* control flow graph). The control flow procedure *Txsort* (lines 47-65) evaluates the graph shown in Figure 7. The resource usage of the graph nodes is defined in lines 48-53. These are vectors and include different types of resource usage information. The parameters *start* and *otcp* are high level language resource usage vectors, the parameter *tlcp* is execution time, and the parameter *merge* is an instruction level resource usage vector. The control flow graph is described in lines 55-64. The *compute* statement accepts one argument which is a resource usage vector while the *loop* statements first argument is a resource usage vector representing the loop overhead per iteration, and the second argument defines the number of repetitions. In all cases the loop overhead has been considered zero.

Parallel Template (bitonic)

```

1  (*
2  * bitonic.la: Bitonic parallel template
3  *)
4
5  partmp bitonic {
6
7      include hardware;      (* Generic Hardware *)
8      include la;           (* Chips System Parameters *)
9
10     (* Interface *)
11     var dtdp numeric:
12         Ndata = 1024,      (* Number of Data *)
13         Clen  = 4,        (* Communication size in bytes *)
14         Tx    = 0;        (* Processing per bitonic stage *)
15
16     (* External static *)
17     var scope numeric:
18         dtp;              (* Data per processor *)
19
20     option {
21         nstage= Log2(hardware.Nproc), (* Number of stages *)
22         seval = 1          (* Evaluate for each step *)
23     }
24
25     (* Entry point *)
26     proc exec init {
27         (* If first stage then initialise variables *)
28         if la.stage == 1 then
29             call InitVar;
30
31         (* Call evaluation for stage *)
32         call EvalStage;
33     }
34
35     (* InitVar - Initialise Variables *)
36     proc exec InitVar {
37         dtp = Clen * Ndata;
38     }
39
40     (* Evaluation for each stage *)
41     proc exec EvalStage {
42         var numeric
43             phase,          (* Communication phases *)
44             tproc;         (* Target processor *)
45
46         phase = la.stage;
47         while( phase > 0 ) {
48             (* Communication Stage for Grid *)
49             step inpcom {

```

```

50         tproc = power(2, phase-1);
51         (*
52         * Communication arguments: Size, From, To
53         *)
54         confdev dtpp*Clen, 0, tproc;
55     }
56     phase = phase - 1;
57 }
58
59 (* And processing stage *)
60 step cpu {
61     (* Set Execution stage *)
62     confdev Tx;
63 }
64 }
65
66 } (* End of partmp *)

```

The name of the parallel template object *bitonic* is defined in line 5. The header of the object (lines 7-23) contains the definition of other objects which are used, the declaration of the interface parameters, and the setting of the options of the objects. The parallel template uses the generic hardware object and the special purpose object *la* that includes parameters related to the status of the CHIP³S run-time evaluation system. The options that are set are: the number of stages of the parallel algorithm, and the flag *seval* that configures the CHIP³S run-time system to evaluate the object once in each stage.

The procedure *init* is executed for each stage (lines 26-33). Only during the first execution, the procedure *InitVar* is called to initialise the variable *ddp* (data elements per processor). To identify the first execution, the parameter *stage* of the *la* object is used (line 28). This parameter is modified by the CHIP³S run-time system and holds the current evaluation stage number. During the execution of every stage the procedure *EvalStage* is called (line 32).

The execution procedure *EvalStage* is defined in lines 36-38. It describes the computation-communication pattern of the *bitonic* template for each stage of the parallel algorithm. The algorithm has a number of communication steps and a single computation step in each stage. The communication steps are described in lines 47-57. The *while* loop determines the number of communication steps (which depends on the current stage of the algorithm). The parameters of each communication step are calculated in the *while* loop, and set in line 54 with the *confdev* statement. The first argument of this statement is the size of the communication, the second is the source processor, and the third is the destination processor. Finally in lines 60-63 the computation step is defined. The *confdev* statement in line 62 determines the time required for this computation phase.

6. Summary & Future Extensions

A performance language, a run-time system for Mathematica, and an evaluation engine have been presented that do not require a user to have expertise in the relevant performance evaluation methodologies. The user, with the performance language, can describe the software and the parallelisation strategies in a way that is both intuitive and more importantly can be used in the performance study.

A number of future extensions will be incorporated into future versions of the CHIP³S language. These include:

- *Bottleneck Analysis*: The operations and use of hardware resources can be analysed by ranking them in order of time costs. By doing this, the predominant classes of operations can be identified as bottlenecks in the overall performance of the system. Such an analysis can be incorporated as a future extension to the CHIP³S toolset. This is being investigated within the PEPS project [PEPS94b].
- *Overlapping Computation-Communication*: One of the features of the modern parallel systems is the ability to overlap the computation and the communication stages of an algorithm. This is a feature that is not currently supported by CHIP³S and requires extensions in the syntax of the parallel template and extensions to the hardware models to support asynchronous communication.
- *Heterogeneous Processing*: The parallel template currently assumes that all processors perform the same computation [Gehring88, Jamieson87]. However there are several classes of algorithms that require the use of different computations assigned to groups of processors. This feature will be supported extending the CHIP³S language and the evaluation engine to allow the creation of trees of computation-communication patterns and use of barriers to synchronise them.
- *Language Syntax Extensions for Different Topologies*: One of the issues that effect the re-usability of the parallel template objects is the mapping of the communication pattern onto the network topology. This currently can be achieved by the explicit use of different user procedures to handle communication patterns for different inter-connection network topologies. A support of this feature from within the syntax of the language will enforce the re-usability of the parallel template objects.
- *Embedded Mathematica Code*: Although the language supports a wide range of general purpose statements, in some cases the use of the Mathematica language might be required. For example, the use of a special purpose Mathematica library that supports advanced statistical functions might be required in a performance study. The use of embedded Mathematica statements in the CHIP³S language will be a future extension.
- *Debugging*: There is the need of a debugging feature to be built into the CHIP³S language. This will allow the user to monitor the use of the objects, the value of the options and interface parameters, and the sequence of internal procedure calls.
- *Library of Generics*: Warwick's characterisation work includes the examination of a range of application areas in order to identify the computational core (also termed generics) which are common across several applications [PEPS93]. Ten generics have been selected, including curve fitting, fast fourier transform, matrix multiplication, etc., and have been further characterised [PEPS94a]. A model library of generics will be developed for the CHIP³S language, which can be used as subtask components in future application studies.

The CHIP³S language, by providing characterisation model reusability, allows easy experimentation, supports different levels of accuracy of predictions, and different levels of model abstraction to assist the system developer, the application programmer, and the performance expert. It can be used to perform a wide range of performance studies. The main concept of CHIP³S is the development of a performance tool for the "rest of us" that will allow the users to perform performance studies.

Bibliography

- [Gehring88] E.F. Gehring, D.P. Siewiorek, and Z. Segall, *Parallel Processing: The Cm* Experience*, Digital Press, 1988.
- [Jamieson87] L.H. Jamieson, Characterizing Parallel Algorithms, L.H. Jamieson, D. Gannon, and R.J. Douglas (Eds.), MIT Press, 1987, pp. 65-100.
- [Miller90] B.P. Miller, M. Clark, J. Hollingsworth, S. Kierstead, S.S. Lim, and T. Torewski, IPS-2: The Second Generation of Parallel Program Measurement System, *IEEE Trans. on Parallel and Distributed Systems*, vol. 1, no. 2, 1990, pp. 206-217.
- [Nudd93] G.R. Nudd, E. Papaefstathiou, Y. Papay, T.J. Atherton, C.T. Clarke, D.J. Kerbyson, A.F. Stratton, R. Ziani, and J. Zemerly, A Layered Approach to the Characterisation of Parallel Systems for Performance Prediction, In: *Proc. of Performance Evaluation of Parallel Systems*, Coventry, UK, 1993, pp. 26-34.
- [Papaefstathiou93] E. Papaefstathiou, D.J. Kerbyson, Characterising Parallel Systems Focusing in Re-Usability, PEPS Bulletin, No. 2, November 1993, pp. 5-6.
- [Papaefstathiou94a] E. Papaefstathiou, D.J. Kerbyson, G.R. Nudd, A Layered Approach to Parallel Software Performance Prediction: A Case Study, In: *Proc. International Conference Massively Parallel Processing, Applications and Development*, Delft, Holland, June 1994.
- [Papaefstathiou94b] E. Papaefstathiou, D.J. Kerbyson, G.R. Nudd, T.J. Atherton, Comparisons of Resource Models within a Parallel System Characterisation Framework, submitted to *Parallel Computing*, 1994.
- [Parashar93] M. Parashar, S. Hariri, G.C. Fox, An Interpretive Framework for Application Performance Prediction, *Technical Report SCCS-479*, Syracuse University, USA, 1993.
- [Pease91] D. Pease, A. Ghafoor, I. Ahmad, L.D. Andrews, K. Foudil-Bey, and E.T. Karpinski, PAWS: A Performance Evaluation Tool for Parallel Computing Systems, *IEEE Computer*, 18-29, January 1991.
- [PEPS93] Characterisation of Processing Needs, *Final Report D5.1*, ESPRIT 6962 - Performance Evaluation of Parallel Systems (PEPS), Parallel Systems Group, University of Warwick, Coventry, UK, 1993.
- [PEPS94a] Parallelisation of Generics, Interim Report D5.3, ESPRIT 6962 - Performance Evaluation of Parallel Systems (PEPS), Parallel Systems Group, University of Warwick, Coventry, UK, 1994.
- [PEPS94b] Analysis of Bottlenecks, Interim Report D5.4, ESPRIT 6962 - Performance Evaluation of Parallel Systems (PEPS), Parallel Systems Group, University of Warwick, Coventry, UK, 1994.
- [Reed92] D.A. Reed, R. Aydt, T.M. Madhyastha, R.J. Nose, K.A. Shields, and B.W. Schwartz, An Overview of PABLO Performance Analysis Environment, Technical Report, University of Illinois, USA, 1992.

Appendix A - YACC Parser Code

```

%{
/*
 * CHIPS Compiler
 * chips.y
 * Compiler Parser Specification
 * -----
 * Parallel Systems Group, DCS, University of Warwick
 * Ver. 1.50 (23/01/95)
 */

#include <stdio.h>

%}

%union {
    char* string;          /* String token value */
    float number;         /* Number token value */
}

%token APPLICATION SUBTASK PARTMP INCLUDE VAR LINK OPTION PROC
%token CFLOW COMPUTE LOOP CALL CASE
%token EXEC IF THEN ELSE WHILE BREAK CONTINUE PRINT
%token RETURN EXIT DIM FREE STEP CONFDEV
%token NUMERIC VECTOR STRING IS ARRAY NUMBER
%token GTE LSE EQL NEQ
%token <string> IDENTIFIER STRCONST

%nonassoc THEN
%nonassoc ELSE

%left '*' '/'
%left '+' '-'
%left '<' '>' GTE LSE
%left EQL NEQ
%nonassoc UMINUS UPLUS
%nonassoc EXPLST

%%

    /* Object Definition */
program:    APPLICATION IDENTIFIER '{' include_lst vardef_lst link_stm
           | option_stm procedure_lst '}'
           | SUBTASK IDENTIFIER '{' include_lst vardef_lst link_stm
           | option_stm procedure_lst '}'
           | PARTMP IDENTIFIER '{' include_lst vardef_lst option_stm
           | procedure_lst '}'
           ;

    /* Include statement */
include_lst: /* Empty */
           | include_lst include_stm
           ;

include_stm:    INCLUDE IDENTIFIER ';'
           ;

    /* Variable definition */
vardef_lst:    /* Empty */
           | vardef_lst vardef_stm

```

```

;

vardef_stm:      VAR IDENTIFIER vartype ':' var_lst ';'

var_lst:        var_opt
                |
                var_lst ',' var_opt
                ;

var_opt:        assignment_opt
                |
                IDENTIFIER
                ;

/* Linking statement */
link_stm:       /* Empty */
                |
                LINK '{' link_body '}'
                ;

link_body:      link_opt
                |
                link_body link_opt
                ;

link_opt:       IDENTIFIER ':' assignment_lst ';'
                ;

/* Option statement */
option_stm:     OPTION '{' option_body '}'
                ;

option_body:    assignment_lst
                ;

/* Procedure List */
procedure_lst:  /* Empty */
                |
                procedure_lst procedure_def
                ;

procedure_def:  proc_cflow
                |
                proc_exec
                ;

/* Control Flow Procedures */
proc_cflow:    PROC CFLOW IDENTIFIER argument_lst '{' locvar_lst
                cflow_lst '}'
                ;

cflow_lst:     /* Empty */
                |
                cflow_lst cflow_stm
                ;

cflow_stm:     COMPUTE vector ';'
                |
                LOOP vector ',' expression '{' cflow_lst '}'
                |
                CASE vector '{' case_lst '}'
                |
                CALL IDENTIFIER ';'
                |
                CALL IDENTIFIER '(' expression_lst ')' ';'
                ;

case_lst:      case_opt
                |
                case_lst case_opt
                ;

case_opt:      expression ':' cflow_lst
                ;

```

```

        /* Execution procedure */
proc_exec:      PROC EXEC IDENTIFIER argument_lst '{' locvar_lst
                exec_lst '}'
                ;

exec_lst:      /* Empty */
                |
                exec_lst exec_stm
                ;

exec_stm:      '{' exec_lst '}'
                |
                assignment_stm ';'
                |
                IF expression THEN exec_stm
                |
                IF expression exec_stm ELSE exec_stm
                |
                WHILE '(' expression ')' exec_stm
                |
                BREAK ';'
                |
                CONTINUE ';'
                |
                PRINT expression_lst ';'
                |
                CALL IDENTIFIER ';'
                |
                CALL IDENTIFIER '(' expression_lst ')' ';'
                |
                RETURN ';'
                |
                RETURN expression ';'
                |
                EXIT ';'
                |
                DIM IDENTIFIER ',' expression ';'
                |
                FREE IDENTIFIER ';'
                |
                STEP '{' exec_lst '}'
                |
                CONFDEV expression_lst ';'
                ;

        /* Other procedure related stuff */
argument_lst:  argument_opt
                |
                argument_lst argument_opt
                ;

argument_opt:  VAR identifier_lst ';'
                ;

locvar_lst:   /* Empty */
                |
                locvar_lst locvar_opt
                ;

locvar_opt:   VAR vartype ':' var_lst ';'
                ;

        /* Data Presentation & Manipulation */
vartype:      NUMERIC
                |
                VECTOR
                |
                STRING
                ;

assignment_lst:  assignment_stm
                |
                assignment_lst ',' assignment_stm
                ;

assignment_stm:  assignment_opt ';'

assignment_opt:  IDENTIFIER '=' expression
                |
                IDENTIFIER '=' vector_const
                |
                IDENTIFIER '=' STRCONST
                ;

expression_lst:  expression %prec EXPLST
                |
                expression_lst ',' expression %prec EXPLST
                ;

```

```

expression:      expression '+' expression
                | expression '-' expression
                | expression '*' expression
                | expression '/' expression
                | expression '>' expression
                | expression '<' expression
                | expression GTE expression
                | expression LSE expression
                | expression EQL expression
                | expression NEQ expression
                | '-' expression %prec UMINUS
                | '+' expression %prec UPLUS
                | '(' expression ')'
                | variable
                | IDENTIFIER '(' expression_lst ')'
                | IDENTIFIER '(' ')'
                | NUMBER
                ;

variable:        IDENTIFIER
                | IDENTIFIER '[' expression ']'
                | IDENTIFIER '.' IDENTIFIER
                ;

vector:          vector_const
                | IDENTIFIER
                ;

vector_const:    '<' IS IDENTIFIER ',' expression_lst '>'
                | '<' NUMBER '>'
                ;

                /* Miscellaneous Definitions */
identifier_lst: IDENTIFIER
                | identifier_lst ',' IDENTIFIER

%%

main()
{
    yyparse();
}

yyerror(char* msg)
{
    printf("Error: %s\n",msg);
}

```

Appendix B - Lex Lexical Analyser Code

```

%{
/*
 * CHIPS Compiler
 * chips.l
 * Compiler Lexical Analyser
 * -----
 * Parallel Systems Group, DCS, University of Warwick
 * Ver. 1.50 (23/01/95)
 */

#include <string.h>
#include "chips.tab.h"

%}

%x      COMMENT STRST

id      [A-Za-z][A-Za-z0-9_]*
number  ([0-9]+|([0-9]*\.[0-9]+)([eE][+-]?[0-9]+)?)
ws      [ \t]+
nl      \n

%%

"(*"          BEGIN COMMENT;
<COMMENT>.    ;
<COMMENT>\n
<COMMENT>"*)" BEGIN INITIAL;

\"           BEGIN STRST;
<STRST>[^\"]*
              {
              yynval.string = strdup(yytext);
              return STRCONST;
              }
<STRST>\"     BEGIN INITIAL;

application { return APPLICATION; }
subtask     { return SUBTASK; }
partmp      { return PARTMP; }
include     { return INCLUDE; }
var         { return VAR; }
link        { return LINK; }
option      { return OPTION; }
proc        { return PROC; }
cflow      { return CFLOW; }
compute     { return COMPUTE; }
loop        { return LOOP; }
call        { return CALL; }
case        { return CASE; }
exec        { return EXEC; }
if          { return IF; }
then        { return THEN; }
else        { return ELSE; }
while       { return WHILE; }
break       { return BREAK; }
continue    { return CONTINUE; }
print       { return PRINT; }
return      { return RETURN; }
exit        { return EXIT; }

```

```
dim      { return DIM; }
free     { return FREE; }
step     { return STEP; }
confdev  { return CONFDEV; }
numeric  { return NUMERIC; }
vector   { return VECTOR; }
string   { return STRING; }
is       { return IS; }
array    { return ARRAY; }

{number} {
    yyval.number = atof(yytext);
    return NUMBER;
}

{ws}     ;

{id}     {
    yyval.string = strdup(yytext);
    return IDENTIFIER;
}

{nl}     ;

.        { return yytext[0]; }

%%
```