



Strathprints Institutional Repository

McGilvray, James W. (1979) A medium term model for Scotland. Quarterly Economic Commentary, 5 (2). pp. 31-40. ISSN 0306-7866 ,

This version is available at <http://strathprints.strath.ac.uk/50595/>

Strathprints is designed to allow users to access the research output of the University of Strathclyde. Unless otherwise explicitly stated on the manuscript, Copyright © and Moral Rights for the papers on this site are retained by the individual authors and/or other copyright owners. Please check the manuscript for details of any other licences that may have been applied. You may not engage in further distribution of the material for any profitmaking activities or any commercial gain. You may freely distribute both the url (<http://strathprints.strath.ac.uk/>) and the content of this paper for research or private study, educational, or not-for-profit purposes without prior permission or charge.

Any correspondence concerning this service should be sent to Strathprints administrator: strathprints@strath.ac.uk

I INTRODUCTION*

The model which is outlined in rather general terms in this paper forms the central core of the Fraser Institute's research programme for the next three years. The model itself is an extension and development of research carried out in the Institute over the past four years, and a synthesis of much of the current work being undertaken.

Between 1975 and 1979, the principal components of the Institute's research work were (a) the construction and implementation of a short-term econometric forecasting model for Scotland and (b) the construction and application of input/output tables for Scotland. More recently, as a more or less autonomous development, members of the Institute have undertaken a number of studies of various aspects of the labour market. Achievement of the initial targets of this research has been followed by an extension and development in all three areas; with respect to econometric forecasting, an extension of the time horizon and the estimation of a more complex model; with respect to input/output, the development of techniques for updating and forecasting the coefficients of the model, and the use of the model for projections of the economic structure; with respect to labour market studies, the interaction of demographic trends and medium-term trends in labour demand and supply, and analyses of the labour force by occupation and industry.

While these areas of research can be defined and pursued in a self-contained way, there is clearly a considerable overlap of interest, and the medium term model of Scotland, besides being of interest in its own right, is designed to provide a focus and consistent frame of reference for these inter-related areas of research. As will be shown, this is reflected in the structure and proposed development of the model. Section II contains a very simplified outline of the structure of the model, identifies its major components, and describes the main linkage between the components or sub-models. In Sections III, IV and V the structures of each of the three major sub-models is discussed in somewhat greater detail. Section VII concludes with some observations on the use and limitations of the model.

Although many of the equations of the model will be estimated econometrically, or will be based on observed data such as input/output tables or occupation-industry matrices, both gaps in data and gaps in our understanding of the determinants of medium and long-term changes in the economy imply a simulation rather than a forecasting model. Nonetheless it is to be hoped that the time paths of the Scottish economy simulated by the model will offer a plausible guide to the actual development of the economy during the next decade and beyond.

II General Structure of the Model

A simplified version of the model is illustrated in Figure 1. The three sub-models are:

- (a) The Macro-economic Model
- (b) The Input/Output Model and
- (c) The Labour Market Model

The Macro-economic model provides the starting point. The main variables in this model are household consumption, private investment (including stock-building), public capital expenditure, public current expenditure, exports to the rest of the UK and exports to the rest of the world, which comprise the principal components of the expenditure side of the national/regional accounts.

* This paper is a summary and distillation of a series of working papers and group discussions centred on the development of the Fraser Institute's Medium Term Model, and I have drawn freely from these papers and discussions. In particular the paper owes much to contributions by David Bell, Frank Kirwan, Ian McNicoll, Lyle Moar and David Simpson, who however bear no responsibilities for the content of the present paper.

FIGURE 1 SIMPLIFIED FLOW DIAGRAM OF THE MEDIUM TERM MODEL

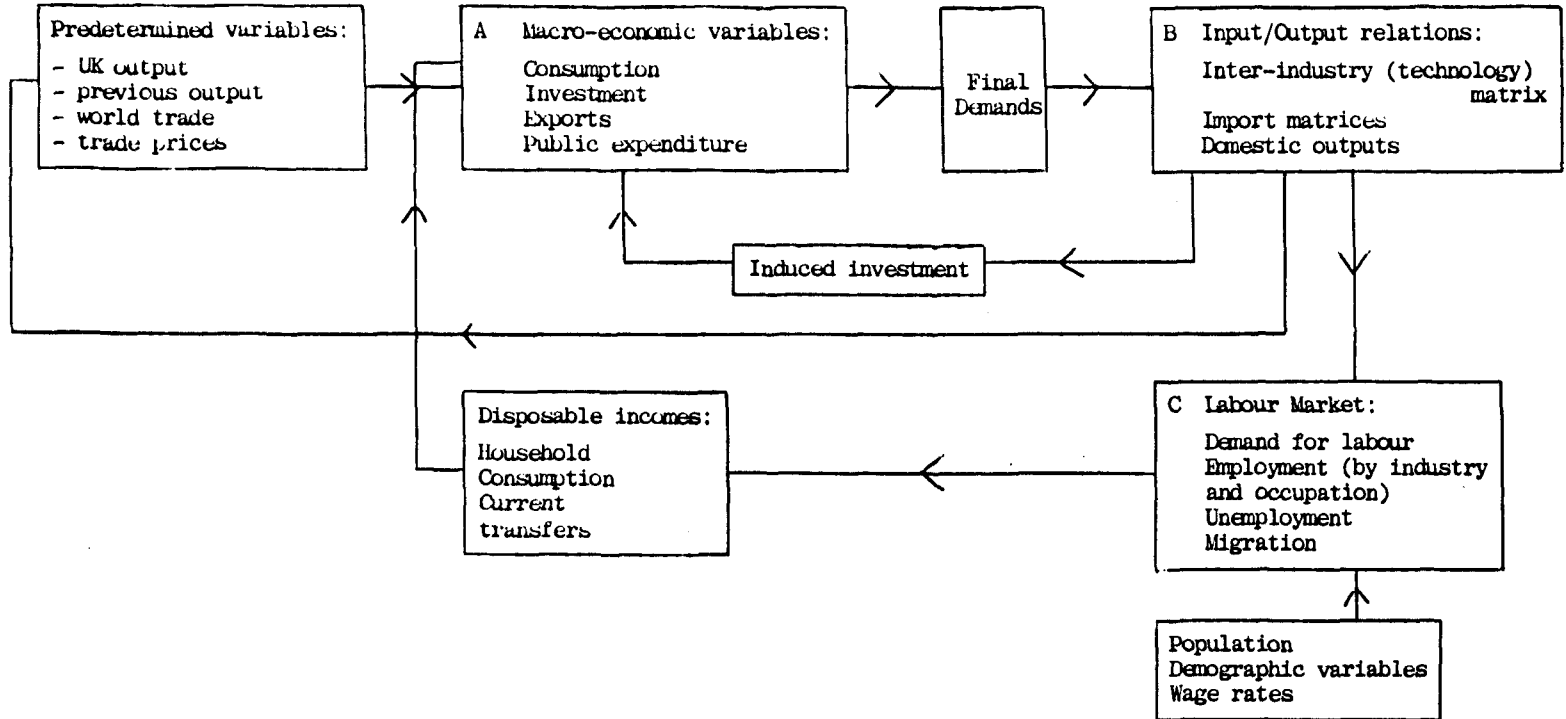

The explanatory variables which determine the level and growth of these expenditure variables fall into three groups: predetermined (lagged) variables, such as last year's level of GDP, manufacturing output, etc; exogenous variables, such as UK GDP, relative world prices for traded manufactures, etc; and endogenous variables whose values are determined elsewhere in the total model, such as household disposable incomes. At this point it may be noted that while in principle the model can be formulated as a system of simultaneous equations, problems of estimating equations, and computational problems suggest an iterative method of solution.

The variables of the Macro-model are linked to the input/output model through a series of conversion matrices which decompose regional accounts aggregates into a matrix of final demands (Figure 1). Each column in this matrix represents a disaggregation of a particular macro-variable in a form corresponding to the system of classification used for the input/output table. Thus total consumption will be broken down into expenditure on the products of Agriculture, of Fishing, of Tobacco, of Clothing etc.

The matrix of final demands constitutes the set of explanatory variables used to solve the second sub-model of the system, which is the Input/Output Model. This model, which distinguishes approximately 45 separate sectors, represents the production or supply side of the system. The solution to the input/output model - which takes the form of a set of simultaneous linear equations - is a vector of industry outputs. Supplementary matrices also determine the proportions of domestic demand met by imports from the rest of the UK and imports from the rest of the world.

An input/output table of 45 x 45 contains 2025 cells and, although many of these will be empty, there will remain a large number of non-zero cells and hence technical coefficients. The matrix of technical coefficients represents the technology of the economy, and a major task here is the updating and forecasting of the technology matrix to reflect current and future technological (input/output) relationships.

Turning now to the Labour Market model, given output levels for each sector the demand for labour can be estimated via inverted sectoral production functions. In turn, these labour demands are decomposed via an occupation-industry matrix to show the demand for labour by occupational group and sex. The supply of labour is determined by the existing labour force (exogenous) and by male and female participation rates, the latter of which will be determined endogenously. The difference between demand and supply gives potential unemployment, though the actual number who register as unemployed (and who thus receive social security benefits) will be less than this, and endogenously-determined net migration rates will further affect the unemployment variable. The level of unemployment, incidentally, is one of the "target variables" of the simulations, the corresponding "policy variables" being tax rates, social security benefits and public sector current and capital expenditures.

To complete the circuit, the labour market model (along with other components of primary input such as profits and taxes) is linked to expenditure and final demands via income generated - household disposable incomes, net government transfers and profits. Description of the model has so far been confined to the real side, and at the present stage the monetary side of the model is less well developed. Nominal wages and the prices of traded goods will be treated as exogenous, while prices of non-traded goods will be determined endogenously. Profits will either be determined residually (in the case of sectors producing traded goods) or be estimated as a constant mark-up on costs (non-traded goods). However it must be admitted that at this stage the monetary side of the model has not been carefully examined; it is not clear, for instance, whether we should attempt to determine relative prices or absolute prices.

Whether expressed in real or money terms, consistency demands that income generated (gross domestic product) should be equal to the sum of final demands less imports. Since the model is not solved simultaneously, a number of iterations may be required before an equilibrium solution is reached.

The output of the model will be substantial but its main features can be summarised as follows:

- (i) Projections of the time paths of the major macro-economic variables (GDP, consumption, investment, public expenditure, exports and imports).
- (ii) analyses of the changing economic/technological structure of the economy and the growth rates of individual sectors of the economy;
- (iii) projections of future supply and demand for labour, migration and the occupational/ industrial composition of the future labour force.

This completes our summary description of the model system. In the following sections (III - V) the three sub-models are discussed in somewhat greater detail. It must be stressed however that the model is at present in the formative stage; the precise form of each of the sub-models, the relations between them, and the monetary side of the model have yet to be elaborated.

III The Macro-Economic Model

Most if not all regional econometric models are formulated as satellites of national models or at least are dependent on one or more exogenously-determined national variables such as GNP or its major components. Such is the case with the Institute's short-term forecasting model (EMOS), developed by D N F Bell, and the present model will be similarly dependent on "national" variables. This requires us to either forecast these national variables ourselves, or to take the forecasts of a national forecasting agency such as the Treasury, LBS or the NIESR. It is proposed to adopt the latter course, probably using the LBS forecasts. These in any case proffer a range of forecasts and thus provide a basis for alternative simulations of the Scottish economy.

Unlike EMOS, however, the present macro-model is expenditure-based rather than output-based. In the latter case for instance one starts with an accounting identity such as

$$(1) \quad GDP_S = GDM_S + GDS_S + GDO_S$$

where

GDP_S = gross domestic product in Scotland

GDM_S = gross product (value added) of manufacturing in Scotland

GDS_S = " " " " " " services " "

GDO_S = " " " " " " other industries "

and then attempts to predict the values of these components of GDP. GDP_S is then the sum of these (predicted) components.

In an expenditure-based model one starts with an accounting identity such as

$$(2) \quad GDE_S = C_S + I_S + G_S + X_S - M_S$$

where

GDE_S = Expenditure on gross domestic output

C_S = Consumption expenditure, I_S = Investment, G_S = Government expenditure,
 X_S = Exports and M_S = Imports

and then attempts to predict the individual expenditure components. This corresponds to the standard Keynesian type model ie it is demand-driven. Although generally conforming to this approach, the present model diverges from the standard form in a number of ways, particularly with respect to trade flows. As already noted imports will be determined through the input/output model, so that the macro-model will initially be couched in terms of total expenditure or total supply, inclusive of imports, and the partition of total supply between domestic output and imports will come at a later stage.

The real headache is export-determination, especially exports to the rest of the UK. There is only one observation on Scottish exports to the rest of the UK, derived from the 1973 Input/Output Tables (Fraser of Allander Institute 1978), so that it is not possible to estimate export functions econometrically. Although a considerable amount of work is being devoted to an analysis of trade patterns in 1973 and to methods of simulating trade flows, it is unlikely that this work will lead to a satisfactorily accurate formulation of export functions (at least for the rest of the UK).

This is an area in which regular survey data could make an invaluable contribution to improving the model. In the meantime, it is probable that exports will be determined in a fairly crude way: by comparing time series of regional outputs with estimates of regional demand and regional imports generated by the model, a time series of exports can be determined residually, and this can be extrapolated using a simple time series model.

Although expenditure variables such as consumption and investment have been expressed above in aggregate terms, the macro-model will be disaggregated to permit estimates of specific expenditure categories such as expenditure on Food, Drink and Tobacco, Clothing, Household Durables, etc, and similarly to differentiate investment outlays on housing, other construction and plant and equipment.

IV The Input/Output Model

The Input/Output model is based on the 1973 Input/Output Tables for Scotland, which contained 78 intermediate sectors of production. This has been aggregated to around 45 sectors. The model itself contains several components of which the most important is the (I - A) matrix or output-determination matrix. This is of the standard, open static form ie

$$(3) \quad X_S = (I - A)^{-1} Y_S$$

where

X_S = a vector of industry outputs (endogenous)

Y_S = a vector of final demands, determined by the macro-model and a series of conversion matrices to decompose consumption, investment, etc into the 45-sector classification scheme

I = an identity matrix

A = the current flow technology matrix

Since the basic data on inter-industry flows relates to 1973, a prime requirement is to update the technology matrix, firstly to the "base-year" from which forecasts will be made (eg 1979) and secondly to the forecast years (eg 1984, 1989). In the absence of hard data on inter-industry flows for any year other than 1973, it is necessary to update and project the technology matrix by indirect methods, and a substantial part of our research input is being presently devoted to the formulation and testing of alternative simulation techniques for this purpose (Harrigan, McGilvray and McNicoll 1979). In a simple form the problem can be formulated as follows:

Given X_0 , A_0 and Y_0 for year 0 (so that $X_0 = (I - A_0)^{-1} Y_0$), and X_1 and Y_1 for year 1, how can we use this information to estimate A_1 , the technology matrix for year 1? A variety of simulation techniques are available for solving problems of this kind, and the present research is designed to test the efficacy of these techniques for the purpose in hand, and possibly to derive new techniques*.

A modification of equation (3) allows imports (imports from the rest of the world and imports from the rest of the UK) to be determined endogenously for example

$$(4) \quad X_S = (I + M - A)^{-1} Y_S$$

where

M = a matrix of import coefficients $\{m_{ij}\}$.

In this case, the model predicts not only domestic (Scottish) output levels but also imports from the rest of the UK and the rest of the world, at 45-sector level of detail. Once again, our sole source of data on imports is the 1973 Input/Output Tables, from which the basic import coefficients are derived, and current research on simulation techniques is also designed to test the stability of these import coefficients. In point of fact, we have some reason to believe that import coefficients, or the large majority of them, will be reasonably stable, so that for any sector i , the share of imports of product i in relation to the domestic supply of product i will be reasonably constant.

A third aspect of the Input/Output model which is worth noting here is its role in generating forecasts of investment expenditure. Ideally, we would like to have a capital coefficient matrix which related expenditure on particular capital goods to changes in the level of output in each sector. Thus

$$(5) \quad B = \{b_{ij}\}$$

denotes a capital flow matrix, where b_{ij} is the outlay on capital good i per unit of incremental output in sector j . However, the best we can do at present is to estimate total investment outlay by sector j per unit of incremental output ie

$$(6) \quad I_j = \sum_i b_{ij} = F(\Delta X_j)$$

*This work, along with other aspects of the Input/Output research programme, is being supported by a grant from the SSRC.

and then attempt to disaggregate I_j according to the 45-sector system of classification.

The levels of investment expenditure estimated in this way will in general differ from those of the Macro-model, and this will require a modification of the original macro-variables and final demands. This is one of the "loops" or "feedbacks" of the system which causes it to be solved in an iterative fashion. The outcome of the Input/Output Model will be a vector of industry outputs, a vector of imports and a vector of investment expenditures, the last of which will require a series of iterations between the macro-model and the input/output model, until a consistent solution is achieved. The vector of outputs then provides a set of explanatory variables for the Labour Market model, to which we now turn.

V The Labour Market Model

Given levels of sectoral outputs determined by the input/output model, sectoral employment levels (expressed in terms of man-years, or numbers employed, or both) can be determined from inverted sectoral production functions:

$$(7) \quad X_j = f(k_j, L_j)$$

$$(7a) \quad L_j = g(k_j, X_j)$$

where X_j is output, k_j is capital stock and L_j is labour employed in sector j . Labour input is normally expressed in man-years, which is the product of numbers employed and average hours, and it is hoped to identify the split between numbers and hours worked using the recursive model suggested by Hart and Sharot (1978).

Once numbers employed have been estimated, these will be disaggregated by occupational group using an occupation-industry matrix, of the form:

$$(8) \quad L = \{l_{sj}\}$$

where l_{sj} is the proportion of employees in sector j who are in the s 'th occupational group.

Occupation-industry matrices for Scotland are presently being constructed on the basis of the 1961, 1966 and 1971 Census data*. Using these three observation points, it is intended to analyse the changing occupational structure of the labour force over the past few years and to derive techniques for updating the matrices to the base and target years.

Analysis of labour demand by occupation has several important applications. Firstly, forecasts of labour demand by occupation enable one to identify potential bottlenecks in labour supply and hence indicate the need for the provision of additional labour training facilities (eg computer programmers, draughtsmen, engineers, etc). Conversely, areas of potential labour surplus can be identified in advance and steps taken to reduce new entrants to certain occupations and to provide re-training facilities to those likely to face redundancies (eg shipbuilding workers).

*This work is being supported by a grant from the Scottish Economic Planning Department.

Secondly, by identifying occupations and industries in which there may be potential excess demand for labour, the model leads us to investigate the possibilities of capital-labour substitution and pressures on wage inflation, which in turn feeds into the monetary side of the model.

On the supply side, at an aggregate level the supply of labour is given by the population in the active age groups modified by age specific participation rates. On the whole male participation rates are stable and can be taken as exogenous. For females the position is more complex, participation rates display a strong trend component and, in the case of married women, strong cyclical sensitivity. Female participation rates will therefore be treated endogenously, with particular attention to the simultaneous nature of the fertility/labour force participation decision.

The discrepancy between labour supply and demand by sex gives a measure of unemployment, both registered and unregistered. The actual number who register as unemployed may be modelled as a function of the actual level of unemployment and the level of unemployment benefits. In turn, this yields an estimate of current government transfers to households which constitute part of household disposable incomes, and which influence consumption expenditure. This is one of the links between the Labour Market model and the Macro-model.

On a macro level the balance between labour supply and demand, and the structure of population, both influence and are influenced by the level of net migration. This will be determined within the model, distinguishing between net migration to the rest of the UK and to the rest of the world. In turn the level of migration in period t affects the level and composition of the population and labour force in period $(t + 1)$. One should add here that the model is dynamic; given the initial conditions and the time profile of the exogenous variables, the model will produce annual GDP, outputs, employment, migration, and so on, so long as the exogenous variables are specified.

The detailed treatment of the labour market, and the incorporation of demographic variables such as fertility, mortality and migration, permits a future extension of the model to incorporate certain elements of public social expenditure - health, housing and education, for example - in a more detailed and explicit way. In turn this helps determine the levels of public current and capital expenditure which are specified in the macro-model.

For given wage and profit rates, and tax rates and benefits, household disposable incomes can be estimated, as well as a set of prices. These then constitute arguments in the expenditure functions of the macro-model, and prices also enter into the arguments of the sectoral production functions, in determining capital/labour ratios. How far we can go in modelling the monetary side of the model is at present uncertain, and in the short run it is probable that the monetary side will simply accommodate to the real side, rather than play a role in the determination of real variables.

VI Summary and concluding comments

In the light of the foregoing discussion, Figure 2 presents a more detailed flow diagram of the principal elements and relationships.

Explanatory variables (RUK output, ROW output (trade), and public expenditure) determine the level of GDP and its principal components, which are then disaggregated to form vectors of final demand. These, in conjunction with relative world/UK prices and exogenous technical change, determine domestic output levels (the 'A' matrix) and imports (the import matrix). Outputs, and sectoral production functions which incorporate changes in labour productivity, determine the demand for labour and employment by occupation and industry. Labour supply is determined by demographic variables, while the difference between supply and demand yields unemployment. Labour market

FIGURE 2 ELABORATED FLOW DIAGRAM: MEDIUM-TERM MODEL

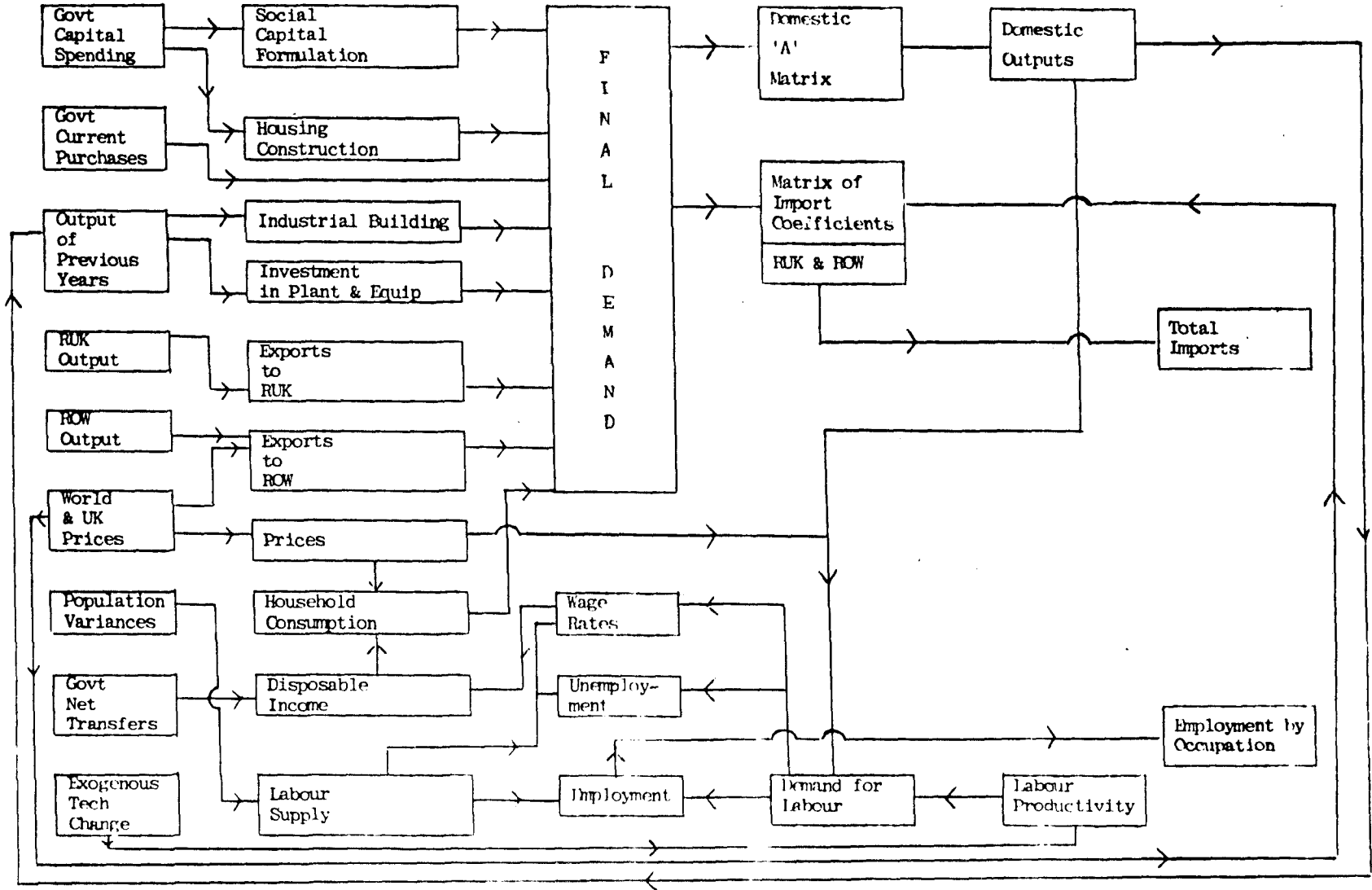

conditions, in conjunction with prices, wages, taxes and unemployment benefits determine disposable incomes and household consumption. Once a set of equilibrium values has been determined for the initial period, we have the necessary lagged endogenous variables required to determine output, etc in the following period. Since the model has not yet been fully specified, problems of under- and/or over-determination will no doubt arise, and it will be necessary to modify the model. In broad outline, however, it is unlikely to be very different from the provisional structure outlined here.

The model is ambitious both in size and scope. At the present stage of development, the quantitative results of the model are less important - though hopefully plausible and interesting - than its value in providing a consistent and interdependent framework for research on different aspects of the economy. There are still many gaps - for instance the model does not incorporate any financial relationships or flows of funds, so that there is no explicit relationship between domestic savings, investment and net capital flows - and others will no doubt become apparent during the course of the work. Indeed one of the hoped-for benefits is precisely the identification of areas where further research is required to obtain a more comprehensive understanding of the workings of the economy.

The most immediate tangible results of the model will be to focus attention on structural change in the Scottish economy over the next decade or so and the implications of such changes for employment, migration and public expenditure. At present, the medium-term employment prospects for the Scottish economy look poor (Bell and Kirwan, 1979) in terms of aggregate labour supply and demand. Results of projections with the medium-term model will provide a much more detailed profile of future output and employment - and thus permit a more critical scrutiny of employment forecasts - as well as allowing us to examine the effects of different scenarios - such as a higher rate of growth of UK output, changing participation rates for female labour, etc - on output and employment. The development of the complete model, and results of projections will be reported in an annual research report, while the development of particular components of the model will be published in a regular series of discussion papers and articles.

REFERENCES

1. Bell, D N F and Kirwan, F X "Population, Employment and Labour Force Projections" Quarterly Economic Commentary, Vol 5 No 1, July 1979.
2. Fraser of Allander Institute, IBM (UK) Scientific Centre, and Scottish Council Research Institute, Input/Output Tables for Scotland 1973, Scottish Academic Press, Edinburgh, 1978.
3. Harrigan, F, McGilvray, J and McNicoll, I, "A Comparison of Regional and National Technical Structures" (mimeo), 1979.
4. Hart, R A and Sharot, T "The Short-run Demand for Workers and Hours: A Recursive Model" The Review of Economic Studies, Vol XLV (2) No 140, June 1978