

Bull. Mater. Sci., Vol. 26, No. 2, February 2003, pp. 207–214. © Indian Academy of Sciences.

The promise of fuel cell-based automobiles

A K SHUKLA*, C L JACKSON[†] and K SCOTT[†]

Solid State and Structural Chemistry Unit, Indian Institute of Science, Bangalore 560 012, India

[†]School of Chemical Engineering and Advanced Materials, Merz Court, University of Newcastle, Newcastle upon Tyne NE1 7RU, UK

MS received 9 December 2002; revised 17 December 2002

Abstract. Fuel cell-based automobiles have gained attention in the last few years due to growing public concern about urban air pollution and consequent environmental problems. From an analysis of the power and energy requirements of a modern car, it is estimated that a base sustainable power of *ca.* 50 kW supplemented with short bursts up to 80 kW will suffice in most driving requirements. The energy demand depends greatly on driving characteristics but under normal usage is expected to be 200 Wh/km. The advantages and disadvantages of candidate fuel-cell systems and various fuels are considered together with the issue of whether the fuel should be converted directly in the fuel cell or should be reformed to hydrogen onboard the vehicle. For fuel cell vehicles to compete successfully with conventional internal-combustion engine vehicles, it appears that direct conversion fuel cells using probably hydrogen, but possibly methanol, are the only realistic contenders for road transportation applications. Among the available fuel cell technologies, polymer–electrolyte fuel cells directly fueled with hydrogen appear to be the best option for powering fuel cell vehicles as there is every prospect that these will exceed the performance of the internal-combustion engine vehicles but for their first cost. A target cost of \$ 50/kW would be mandatory to make polymer–electrolyte fuel cells competitive with the internal combustion engines and can only be achieved with design changes that would substantially reduce the quantity of materials used. At present, prominent car manufacturers are deploying important research and development efforts to develop fuel cell vehicles and are projecting to start production by 2005.

Keywords. Polymer–electrolyte fuel cells; fuel cell-based automobiles; fuel cell vehicles; internal-combustion engine vehicles; direct methanol fuel cells.

1. Introduction

In the late 1890s, at the dawn of the automobile era, steam, gasoline and electric vehicles all competed to become the dominant automobile technology. By the early 1900s, the battle was over and internal combustion engine vehicles (ICEVs) were poised to become the prime movers of the twentieth century. At present, about 60 million ICEVs are manufactured every year worldwide and it is projected that there would be about a billion ICEVs on the earth's roads by 2002 that is one for every seven people. This upsurge in the use of ICEVs is causing considerable pollution problems in our urban conurbations. This has brought in emission legislation all over the world requiring the induction of zero-emission vehicles (ZEVs). The situation is so alarming that the city of London has recently announced to impose a congestion tax on ICEV users from mid 2003. Interestingly, such a tax is first of its type in the western world.

ZEVs were initially thought to mean battery-powered vehicles. However, pure battery-powered vehicles are no

longer regarded as an acceptable alternative to ICEVs except possibly as neighbourhood electric vehicles which are designed to provide low-speed (*ca.* 45 km/h) transportation in restricted areas such as university campuses, hospitals, airports, theme parks, industrial parks, holiday resorts, residential complexes and city centres (Electric Vehicles 1993; Staff Report 1998).

The above situation does not imply that there are no legitimate uses of pure battery-powered electric cars today as fleet vehicles, as community cars and as second cars for families that already own a gasoline automobile for long-distance travel. One solution to this enigma might be to take the pure battery-powered electric cars out of the developmental laboratories and put them in hands of the real drivers. Some will find these vehicles inadequate, but many others may not. With this proposition in mind, Saturn, in partnership with General Motors Advanced Technology Vehicles, now offers GEN II EV1 to consumers through a lease-only program. Select Saturn retail facilities in California and Arizona distribute and service EV1. Saturn believes that this is the best way to ensure total customer enthusiasm for the early customers in their vehicle. Leasing will provide the customers with a known, consistent cost of ownership. Saturn covers all

*Author for correspondence

routine maintenance and service under the terms of 3-year/36000-miles new-vehicle limited warranty. This includes everything from batteries to tyres. Saturn also provides a 24-hour roadside assistance program to make every aspect of EV1 lease trouble-free. While the fate of pure battery-powered electric cars hangs in limbo, the last five years has seen a dramatic development in fuel cells which have advanced to the point where manufacturers believe that the technology is commercially viable and capable of delivering sufficient energy for running the cars (Nolte, in press; Friedlmeier *et al* 2001). Automotive industry leaders project that within two decades, between 7 and 20% of new cars sold in the world will be powered by fuel cells. Accordingly, we can envision a global fleet of as many as ~ 80 million fuel cell vehicles (FCVs) on the earth's roads by 2020.

In this article, we appraise the progress made in the development of fuel cell-based automobiles and present a prognosis on the commercial viability of this technology.

2. Power and energy requirements of fuel cell-based automobiles

To assess the energy and power requirements of a fuel cell-based automobile, it is appropriate to quantitatively estimate the power and energy required for driving a modern ICEV (Shukla *et al* 2001). Neglecting relatively minor losses due to road camber and curvature, the power required at the drive wheel (P_{traction}) may be expressed as,

$$P_{\text{traction}} = P_{\text{grade}} + P_{\text{accel}} + P_{\text{tyres}} + P_{\text{aero}}, \quad (1)$$

where P_{grade} is the power (W) required for the gradient, P_{accel} the power (W) required for acceleration, P_{tyres} the rolling resistance power (W) consumed by the tyres, and P_{aero} the power (W) consumed by the aerodynamic drag.

The first two terms in (1) describe the rates of change of potential (PE) and kinetic (KE) energies associated during climbing and acceleration, respectively. The power required for these actions may be estimated from the Newtonian mechanics as follows

$$P_{\text{grade}} = d(\text{PE})/dt = Mg v \sin \mathbf{q}, \quad (2)$$

and,

$$P_{\text{accel}} = d(\text{KE})/dt = d(1/2 Mv^2)/dt = Mav, \quad (3)$$

where M is the mass (kg) of the car, v its velocity (m/s), a its acceleration (m/s^2), and \mathbf{q} the gradient. The potential and kinetic energies acquired by the car as a result of climbing and acceleration represent reversibly stored energies and, in principle, may be recovered by appropriate regenerative methods wherein the mechanical energy is converted and stored as electrical energy.

The last two terms in (1) describe the power, which is required to overcome tyre friction and aerodynamic drag, that are irreversibly lost, mainly as heat and noise and

cannot be recovered. The power required here may be estimated from the following empirical relations

$$P_{\text{tyres}} = C_t Mgv, \quad (4)$$

and,

$$P_{\text{aero}} = 0.5 dC_a A (v + w)^2 v, \quad (5)$$

where C_t and C_a are dimensionless tyre friction and aerodynamic drag coefficients, respectively, d the air density (kg/m^3), w the head-wind velocity (m/s), g ($= 9.8\text{m/s}^2$) the gravitational acceleration, and A the frontal cross-sectional area (m^2) of the car.

From the parameters associated with a typical modern medium-size car, viz. $M = 1400$ kg, $A = 2.2$ m^2 , $C_t = 0.01$, $C_a = 0.3$, $d = 1.17$ kg/m^3 , its power requirements may be estimated from (2)–(5). For the irreversible losses, (4) and (5) show that while P_{tyres} is linearly dependent on velocity, P_{aero} varies as the third power of velocity and although negligible at low velocities, the latter becomes the dominant irreversible loss at high speed. As an example, for these parameters, for a car travelling at about 50 km/h, tyre friction is twice the aerodynamic drag and together amount to about 3 kW. At 100 km/h highway cruising, aerodynamic drag increases considerably to over twice the tyre friction, increasing the total power requirement to about 12 kW. It is noteworthy that for both these estimates, the wind speed (w) has been taken to be zero for the sake of simplicity. But, in practice, the effect of wind speed on the performance of the car could be quite substantial. For example, P_{aero} at a favourable tail wind speed of 30 km/h will be as low as 0.8 kW but would amount to 4 kW at a similar opposing tail wind velocity. Accordingly, the energy performance of the car will drop from 40 km/kWh to 15 km/kWh (Wicks and Marchionne 1992). Taking the example of a hill with a substantial 10% gradient, climbing at 80 km/h requires about 38 kW, including tyre friction and aerodynamic drag. Acceleration is more demanding, particularly at high velocities. For example, acceleration at 5 km/h/s requires 30 kW at 50 km/h and increases to 66 kW at 100 km/h.

The above estimates are for the power supplied to the wheel of the car and do not include the losses incurred in delivering that power to the wheels. At this time in the development of electric-traction systems, a precise estimate of this is difficult to obtain but anecdotal information suggests that the efficiency of the power conditioning electronics together with the electrical and mechanical drive train is likely to be about 0.85. Additional power may also be required to power the accessories like radio, lights, steering, and air-conditioning, etc which is likely to add about 5 kW to the total power demand of the car.

An analysis of this kind indicates that the power plant of a modern car must be capable of delivering about 50 kW of sustained power for accessories and hill climbing, with burst-power requirement for a few tens of

seconds to about 80 kW during acceleration. For a car with these performance characteristics, this sets the upper power limit required, but in common usage rarely exceeds 15 kW while cruising.

The heating value of gasoline fuel is 32.5 MJ/l and a heating value of only 6.5 MJ/l will be available with an ICEV of near 20% well-to-wheel efficiency. This is about 1.82 kWh/l of the gasoline fuel and considering the average drive range of the car with the parameters listed above as ~ 10 km/l, it would amount to 182 Wh/km. The heating value of the diesel fuel is 35.95 MJ/l and accordingly the estimated energy will be 201 Wh/km for the diesel-driven cars, which have well-to-wheel efficiency of about 30% and a drive range of ~ 15 km/l. It is mandatory that FCVs meet these power and energy requirements.

3. Commercial viability of fuel cell-based automobiles

In the preceding section, both the power and energy demands of a modern car were discussed. In brief, it was concluded that a base sustainable power of 50 kW, supplemented with short bursts to 80 kW would suffice in most driving requirements. Energy demand depends greatly on driving characteristics, but under normal usage can be expected to be about 200 Wh/km.

3.1 Power and energy densities for polymer–electrolyte fuel cells

There are six generic fuel cell systems (Kordesch and Simader 1994; Larminie and Dicks 2000; Carrette *et al*

2001), viz. (i) phosphoric acid fuel cells (PAFCs), (ii) alkaline fuel cells (AFCs), (iii) polymer–electrolyte fuel cells (PEFCs), (iv) molten carbonate fuel cells (MCFCs), (v) solid oxide fuel cells (SOFCs), and (vi) direct methanol fuel cells (DMFCs), in various stages of their development. But for automobiles, the low-operating temperature and rapid start-up characteristics, together with its robust solid-state construction give the PEFCs (figure 1) a clear advantage for application in cars. Since the specific energy density of PEFC power plants (~ 1 kWh/kg) is akin to that of the present day ICEVs, comparable driving ranges may be expected. But the power density (~ 300 W/kg) of the present day PEFCs tends to be substantially lesser than that of the ICEVs (~ 600 W/kg). A Ragone plot comparing the power and energy densities of PEFCs and IC engines is given in figure 2. The fuel cell system energy efficiency at present is about 60%, which is much higher than both the Otto (*ca.* 20%) as well as Diesel (*ca.* 30%) versions of ICEVs (Jeong and Oh 1999). Although, the 80 kW of the power needed to provide the acceleration to the fuel cell-based automobile could be supplied by an appropriately sized PEFC alone, this will probably make the first generation systems excessively large and heavy. Additionally, the high cost of newly developed fuel cells will persuade the car makers to use the smallest cells that will provide the required base power needs of about 50 kW.

3.2 Fuel options for FCVs

Hydrogen, methanol and gasoline can be used as fuels in FCVs (Thomas *et al* 2000). Possible FCV configurations (Ogden *et al* 1999) are depicted in figure 3. In brief, these configurations comprise a fuel cell system, a

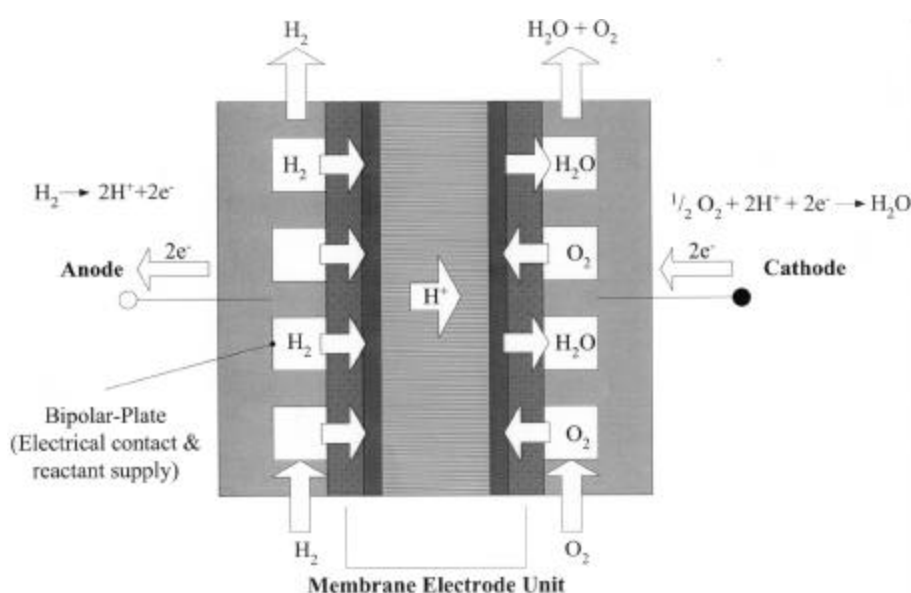

Figure 1. Schematic diagram of a polymer–electrolyte fuel cell (PEFC).

driving mechanism, which consists of a fuel supply system, an air supply system, a humidification system, and a thermal manager to control the operating temperature of the fuel cell stack.

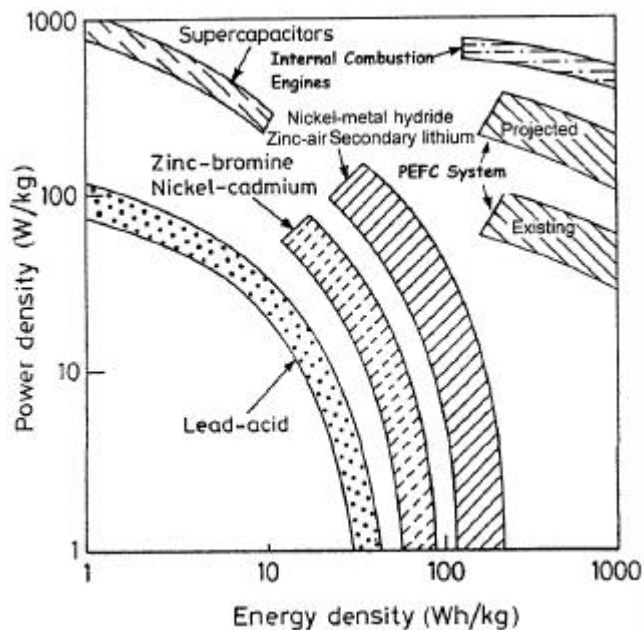

Figure 2. A Ragone plot comparison of power and energy densities for supercapacitors, batteries, PEFCs (including reformer), and IC engines.

Gasoline and in principle methanol can be supplied through the existing fuel distribution network for vehicles. But, a fuel reformer would be required to produce hydrogen from gasoline or methanol. This will increase both the complexity and the cost of FCVs. Furthermore, with the reformers, the start-up time to normal operation reportedly varies from a few minutes upwards. Experts believe that for fuel cell-based automobiles, with an onboard fuel processor, it may be difficult to exceed the performance of the future ICEVs in terms of emission, efficiency, drivability, maintenance and first cost (McNicol *et al* 2001). Besides, at the operating temperatures of the PEFCs, carbon monoxide even at only 0.1% is sufficient to poison the platinum catalyst at the anode. Therefore, either a separate process or new carbon monoxide tolerant catalysts need to be developed for deployment at the anode (Shukla *et al* 1999). However, when hydrogen is used, a fuel processor is not necessary, and start-up time and response to load change are fast. But, hydrogen infrastructure costs are currently unacceptably high. Costs of tens to hundreds of billions of dollars are often quoted. Hydrogen onboard a vehicle can be stored as liquid hydrogen, as compressed hydrogen, as metal hydrides and as hydrogen absorbed in carbon nanotubes. The energy density of liquid hydrogen is appreciably high. But, to store hydrogen in liquid state, it is mandatory to maintain a temperature as low as -253°C at ambient pressure. This requires a highly insulated hydro-

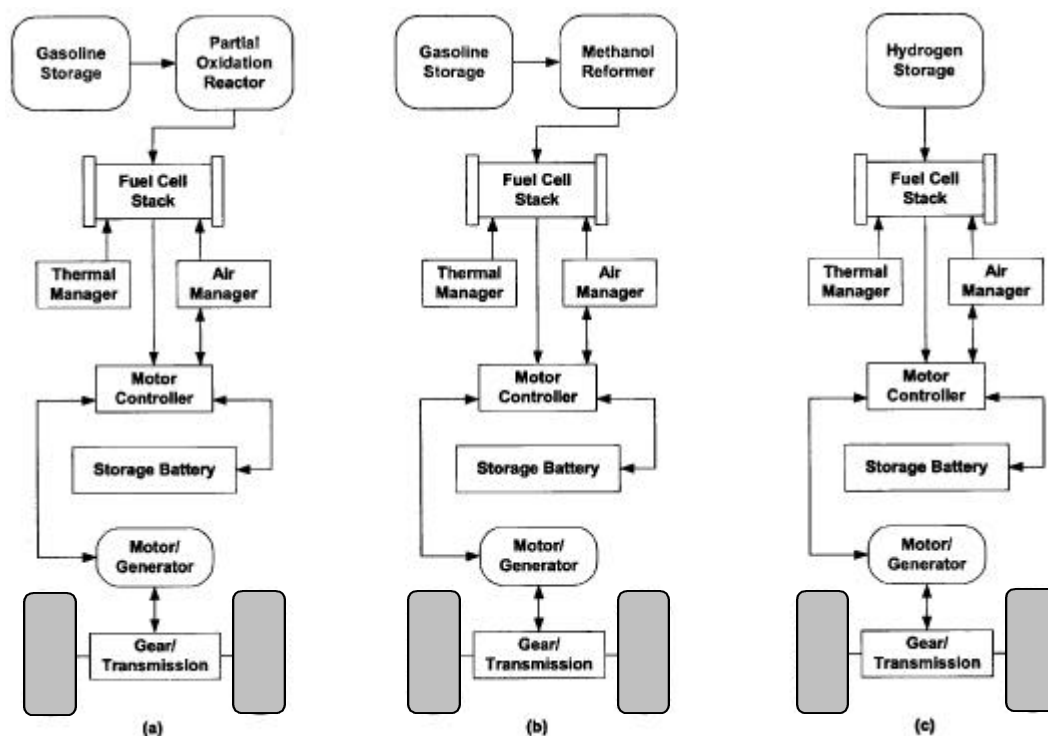

Figure 3. (a) Gasoline partial oxidation reactor FCV (range = 29–42 mpgge), (b) methanol FCV (range = 43–48 mpgge), and (c) direct hydrogen FCV (range = 66 mpgge). The driving ranges for the ICEVs are about 30 mpgge.

gen tank making it cost intensive. Metal hydrides are heavy and time consuming for storing hydrogen. Carbon nanotubes are still in their developmental stage but the US Department of Energy development goal for these is slightly above the performance of the actual liquid hydrogen tank. The stored energy is low in the case of compressed hydrogen.

3.3 Industrial activity on FCVs

Prominent car manufacturers undertaking the development of fuel cell-based automobiles are Daimler-Chrysler who have a joint venture with Ballard, Excellsis, Ecostar and Ford, General Motors jointly with Opel, De Nora S.p.a., Fiat, Peugeot in association with Citroën, Volkswagen in association with Volvo, Daewoo Motor, Daihatsu, Mitsubishi, Suzuki, Honda, Hyundai, Mazda, Nissan, Renault, Toyota, and ZeVco. While some of these manufacturers are attempting to develop pure fuel cell powered automobiles (figure 3), some are endeavouring to develop vehicles either with a fuel cell-battery hybrid system or with a fuel cell-supercapacitor hybrid system (figure 4).

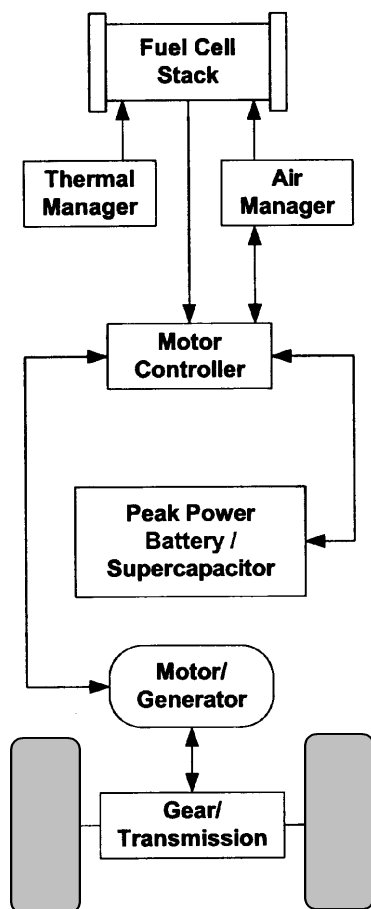

Figure 4. Hybrid FCVs with battery and supercapacitor systems.

In a clear demonstration of its commitment to have fuel-cell cars in series production by 2004, Daimler-Chrysler unveiled its NECAR-4 (New Electric Car) version in US on March 17, 1999. Its fuel cell power output has been increased by 40%, giving it a top speed of 145 km/h, acceleration to 48 km/h in 6 s and a range of up to 450 km, which is comparable to conventional ICEVs. Like its predecessor NECAR-3, the new car is based on a Mercedes-Benz A-Class sub-compact car, which has a sandwich floor construction within which the system can be installed. For the first time, the complete PEFC system is mounted in the vehicle floor, allowing room for up to five passengers and cargo space. It is powered by liquid hydrogen stored in a cryogenic cylinder that takes up a part of the car boot. The engine was developed by Daimler Benz-Ballard (dbb) Fuel Cell Engines GmbH, while the vehicle uses an electric drive train from Ecostar Electric Drive Systems, a joint venture between Daimler-Chrysler, Ford and Ballard; the latter supplied the fuel cell stacks. Daimler-Chrysler believes that the most challenging problems have been solved. The company will invest more than \$ 1.4 billion on fuel cell technology development by the time the first FCVs come to market. This is about the same amount of money spent to introduce an entire line of profit-making vehicles, such as the Chrysler 300 M, Chrysler Concorde, Chrysler LHS and Dodge Intrepid. The new race is to make them affordable. This is because to achieve widespread acceptance in coming years, the electric cars must have a clear economic advantage over ICEVs.

Ford plans to bring a new line of fuel cell cars based on its current Ford P2000 prototype. Ford FCVs will use tanks of liquid or gaseous hydrogen and will also be powered with Ballard's PEFC stack. The electricity generated from the fuel cell stack will be used by the car's electric induction motor/transaxle and electric power inverter to produce up to 90 kW of power. Ford also introduced a P2000 SUV concept, a sport utility vehicle that will feature a fuel cell engine with a methanol reformer.

BMW in association with IFC, Messer AG, Linde and Solar Millennium AG is also developing a fuel cell vehicle. Renault SA of France and Nissan Motor Co. have decided to develop cars with fuel cells that run on gasoline. Renault is working with PSA Citroën to speed up the development of a commercially viable fuel cell car by 2010. Volkswagen introduced its first fuel cell-powered car at the California Fuel Cell Partnership headquarters' opening. The ZEV is called Bora HyMotion and its fuel cell engine runs on hydrogen and has a power output of 75 kW. Volkswagen is involved with CAPRI on a project to develop a prototype methanol FCV. Ballard will supply the fuel cell and Johnson Matthey a HotSpot reformer. In a joint project, Volvo and Volkswagen have announced plans for a methanol-fuelled PEFC hybrid golf-type car. London's Westminster City council has bought a fuel cell

van from ZeVco for \$ 47000 for the upkeep of London's parks. It has a top speed of 100 km/h and is 50% cheaper to run than a conventional ICEV.

Other major players in the FCVs are General Motors in association with Opel. Following the successful demonstration of their Opel Fuel Cell Zafira with methanol reformer at the Paris Motor Show in October 1998, Opel and General Motors tested their liquid hydrogen fueled Opel HydroGen1 at the Living Tomorrow Workshop at Brussels during June 2000 with a drive range of 400 km (Nolte *et al*, in press). Interestingly, the liquid hydrogen tank used with HydroGen1 had an energy density of about 5 MJ/l and 6 MJ/kg, which is significantly higher than that for the ICEVs (Nolte *et al*, in press). GM's Delphi subsidiary is working with ARCO and Exxon to jointly develop onboard fuel processing technology and hardware to convert gasoline to hydrogen for use in PEFC systems.

In Asia, Daewoo Motor, Diahatsu, Honda, Hyundai, Mazda, Mitsubishi, Nissan, Suzuki, and Toyota have been involved in developing FCVs. Daewoo Motor reports that it will embark on a fuel cell research and development program with a state-run laboratory. Diahatsu presented its MOVE FCV-K-II, a four-seater FCV, which uses a high-pressure hydrogen tank system. The MOVE-FCV-K-II uses a 30 kW Toyota fuel cell stack installed beneath the floor at the rear of the vehicle. Honda has developed a four-seater FCV, called the FCX-V3, which will be road-tested under the California Fuel Cell Partnership program. Honda plans to build 300 FCVs during 2003 for sale in Japan. United Technologies Corp. Fuel Cells and Hyundai have worked together to produce Santa Fe FCV. Suzuki unveiled a fuel cell powered Covie two-seater at the 2001 Tokyo Motor Show. The vehicle features a GM fuel cell stack and uses natural gas as the fuel. The Hyundai Santa Fe FCV powered by a 75 kW PEFC stack scored best in two key performance tests at the Michelin Challenge Bibendum, an annual event where new automotive technologies are evaluated by independent judges. Toyota has demonstrated its new fuel cell hybrid vehicle, called the FCHV-4, based on the new Highlander SUV. Toyota says that their FCV with a cruising range of about 250 km has three times the vehicle efficiency of an ICEV. Toyota has also unveiled its FCHV-5, which runs on clean hydrocarbon. Toyota plans to launch a commercial FCV in 2003. Exxon and Toyota are working together on technology to extract hydrogen from gasoline. Toyota keeps methanol as the preferred option in the near term.

3.4 Cost projection for PEFCs

The present estimated cost of PEFCs is about \$ 1000–2000/kW (Jeong and Oh 2002), which is a constraint for their commercialization and use in automotive applica-

tions. The fuel cell cost could be decreased through reduction of platinum loading, improvement in stack performance, and mass production. It is hoped that the PEFC cost will be decreased to 200/kW in 1–2 years (Jeong and Oh 2002). In the US, the target cost of fuel cell systems to be achieved by 2005 is \$ 50/kW (Bar-On *et al* 2002). This could be achievable for a PEFC with a peak power density of 0.5 W/cm² using platinum catalyst loadings of 0.2 mg/cm² giving a catalyst cost of \$ 12–\$ 14/kW providing membrane costs are less than \$ 100/m² (or \$ 20/kW). GM claims to have achieved the fuel cell stacks with \$ 50/kW and is working to further reduce the cost to \$ 20/kW. In a recent technical cost analysis for PEFCs (Bar-On *et al* 2002), it is surmised that this target cost can only be achieved with design changes that would substantially reduce the quantity of materials used. This obviously calls for more research and development on advanced and cost-effective fuel cell materials.

It has been demonstrated (Jeong and Oh 2002) that if the fuel cell cost is high (\$ 1000–2000/kW) then hybridization can reduce the life-cycle cost (initial vehicle cost plus maintenance cost) of the FCVs. But if the fuel cell cost is \$ 50/kW then hybridization increases the life-cycle cost of the FCVs as it increases the initial vehicle cost.

4. Problems and technology alternatives

The problems that remain to be tackled in the commercialization of the FCAs are: (i) reduction in cost, weight and volume of fuel cell systems, (ii) further improvements in driving dynamics, durability and reliability, development of cost-effective production technologies, and (iii) installation of refuelling infrastructure for hydrogen.

An elegant solution to the problems associated with the installation of refuelling infrastructure for hydrogen fuel lies in operating the PEFC directly with a liquid fuel. Much consideration is therefore being given to PEFCs that run on air plus a mixture of methanol and water. Methanol being liquid can be easily transported and dispensed within the current fuel network. Methanol has long-term environmental benefits because it could be produced renewably. Methanol is cheap and plentiful, and the only products of combustion in the fuel cell are carbon dioxide and water (figure 5). The advantages of direct methanol fuel cells (DMFCs) are that the changes in power demand can be simply accommodated by altering the supply of the methanol feed. The potential efficiency of a DMFC for an operational cell potential of 0.5 V is about 40% and its specific energy is *ca.* 6 kWh/kg (Lamy and Léger 1997). Since DMFCs operate at temperatures below 150°C, there is no production of NO_x. Methanol is also stable in contact with mineral

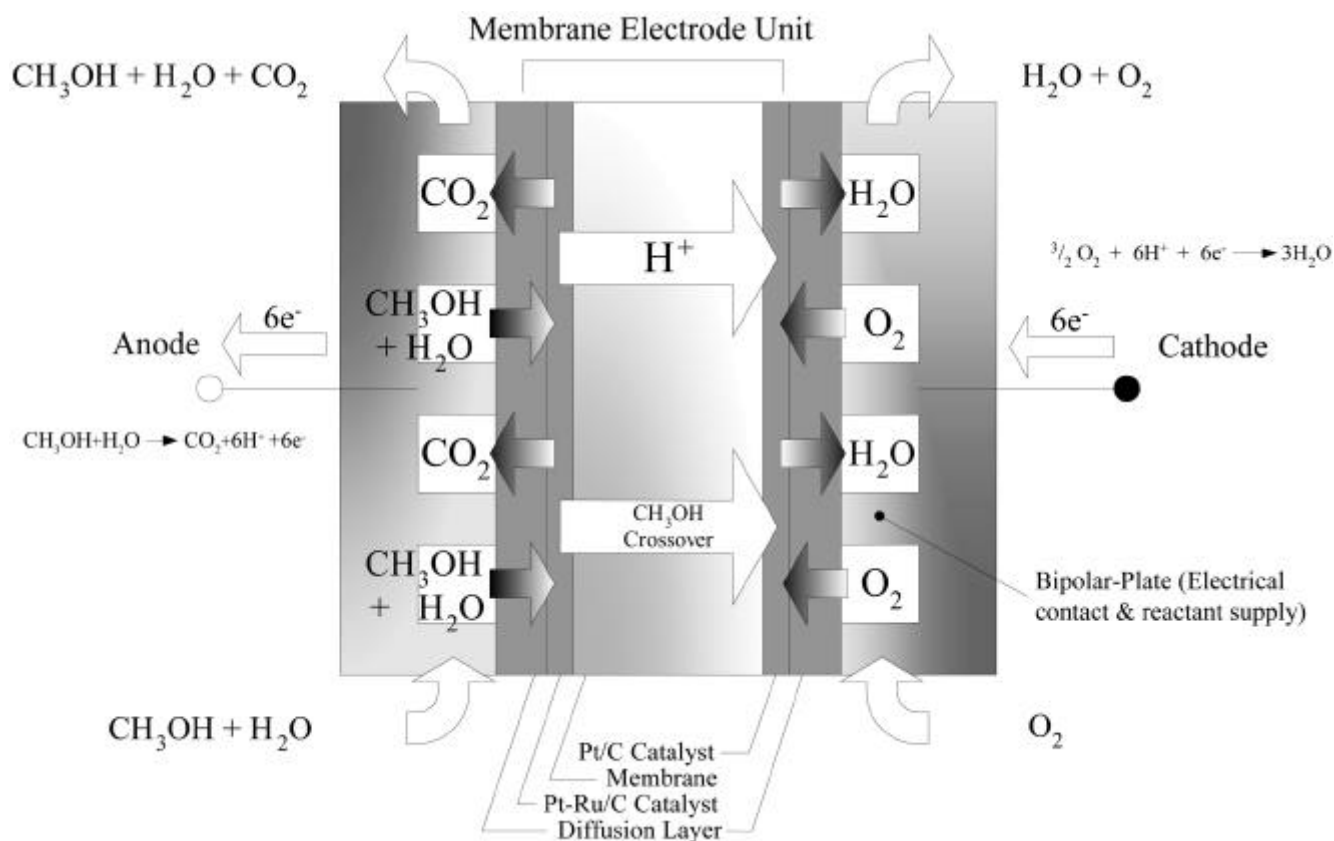

Figure 5. Schematic diagram of a direct methanol fuel cell (DMFC).

acids or acidic membranes, and it is easy to manufacture. Above all, the use of methanol directly as an electrochemically active fuel highly simplifies the engineering problems at the front end of the cell, driving down complexity and hence cost. A DMFC stack operating with a power density of *ca.* 0.25 W/cm² would be about the same size as a methanol reformer/PEFC system operating with a power density of about 1 W/cm².

During the last decade, significant advances have been made in the DMFC development. Power densities of 450 and 300 mW/cm² under oxygen and air-feed operation, respectively, and 200 mW/cm² at a cell potential of 0.5 V have been reported for cell operating at temperatures close to or above 100°C under pressurized condition with platinum loadings of 1–2 mg/cm² (Aricò *et al* 2001). Besides, the development of DMFC stacks for both transportation and portable applications has gained momentum in the last 2–3 years, and stack power densities of 1 kW/l and an overall efficiency of 37% at a design point of 0.5 V per cell have been accomplished (Ren *et al* 2000). The performance of DMFCs is thus competitive with respect to the reformer-based hydrogen/air PEFCs, especially if one considers the complexity of the latter whole system (Shukla *et al* 2001). However, further improvements in the performance of DMFCs would be mandatory for their use in FCVs (Acres 2001).

A step in this direction appears to be the development of mixed-reactant DMFCs which rely upon the selectivity of anode and cathode electrocatalysts to separate the electrochemical oxidation and reduction of the oxidant without the need for physical separation of fuel and oxidant (Barton *et al* 2001; Priestnall *et al* 2001). In the mixed-reactant DMFCs, there would be no need for gas-tight structures within the stack providing relaxation for sealing and reactant delivery structures (Scott *et al*, unpublished).

In the last few years, much progress has been made in bringing methanol fuel cell technology closer to the marketplace. On November 9, 2000, Ballard Power Systems and Daimler-Chrysler unveiled a DMFC prototype in Stuttgart, Germany, which used aqueous methanol to power a one-person demonstration vehicle. The main technological challenges here are to develop better anode catalysts, to overcome efficiency losses at the anode and to improve the membrane electrolytes as well as to find methanol-resistant cathode catalysts to prevent its methanol poisoning. Other alcohols, such as ethanol, ethylene glycol, propanol and diethyl ether, and borohydrides have also been considered for use in fuel cells (Lamy *et al* 2002), but DMFCs undisputedly remain the most advanced systems in the category of direct alcohol fuel cells (DAFCs) (Lamy *et al* 2000).

Today, methanol is being produced from otherwise flared or vented natural gas in many parts of the world. If only 10% of the natural gas flared each year was made available for the methanol fuel market, it would be enough to power 9.5 million FCVs annually. Besides, the technology to produce methanol from renewable feedstocks such as wood, municipal solid waste, agricultural feed stocks and sewage has been widely demonstrated. Accordingly, the availability and cost of methanol is probably not going to be the roadblock. The current US methanol production capacity stands at 35.7 million tons per year, and the wholesale spot market price for methanol is 33 cents per gallon. Methanol fuel cell vehicles (MFCVs) are indeed found to be so attractive that in order to develop readily accepted specifications for the safe and effective use of methanol in MFCVs, representatives from the oil, automotive and methanol industries have recently formed Methanol Specification Council.

5. Conclusions

At present, direct hydrogen FCVs fuelled with liquid hydrogen appear to be the best option. However, these are faced with problems such as high cost of PEFC stacks, their weight and volume, and absence of hydrogen refuelling infrastructure. Even with these drawbacks, world's major automakers are racing to introduce FCVs in the market, and some of them as early as the middle of this decade.

References

- Acres G J K 2001 *J. Power Sources* **100** 60
- Aricò A S, Srinivasan S and Antonucci V 2001 *Fuel Cells* **11**
- Bar-On I, Kirchain R and Roth R 2002 *J. Power Sources* **109** 71
- Barton S C, Patterson T, Wang E, Fuller T F and West A C 2001 *J. Power Sources* **96** 329
- Carrette L, Friedrich K A and Stimming U 2001 *Fuel Cells* **1** 5
- Electric Vehicles: Technology, Performance and Potential 1993
OECD/IEA Publication
- Friedlmeier G, Friedrich J and Panik F 2001 *Fuel Cells* **1** 92
- Jeong K S and Oh B S 2002 *J. Power Sources* **105** 58
- Kordesch K and Simader G 1994 *Fuel cells and their applications* (Weinheim: VCH)
- Lamy C and Léger J-M 1997 in *Proc. 2nd international symposium on new materials for fuel cells and modern battery systems* (eds) O Savadoga and P R Roberge (Montreal, Canada) pp 477–488
- Lamy C, Léger J-M and Srinivasan S 2000 *Modern aspects of electrochemistry* (eds) J O'M Bockris and B E Conway (New York: Plenum Press) **Vol. 34**, Ch. 3, pp 53–117
- Lamy C, Lima A, LeRuhn V, Delime F, Contanceau C and Léger J-M 2002 *J. Power Sources* **105** 181
- Larminie J and Dicks A 2000 *Fuel cell systems explained* (New York: Wiley)
- Menicol B D, Rand D A J and Williams K R W 2001 *J. Power Sources* **100** 47
- Nolte R *J. Power Sources* (in press)
- Ogden J M, Steinbugler M M and Kreutz T G 1999 *J. Power Sources* **79** 143
- Priestnall M A, Kotzeva V P and Fish D J 2002 *J. Power Sources* **106** 21
- Ren X, Zelanay P, Thomas S, Davey J and Gottesfeld S 2000 *J. Power Sources* **86** 11
- Scott K, Shukla A K, Jackson C L and Meuleman W R A, unpublished
- Shukla A K, Avery N R and Muddle B C 1999 *Curr. Sci.* **77** 1141
- Shukla A K, Aricò A S and Antonucci V 2001 *Renewable and Sustainable Energy Reviews* **5** 137
- Staff Report 1998 Zero-Emission Vehicles Biennial Program Review, California Air Resource Board
- Thomas C E, James B D, Lomax Jr F D and Kuhn Jr I F 2000 *J. Power Sources* **25** 551
- Wicks F E and Marchionne D 1992 *Proc. 27th intersociety energy conversion engineering conference* (Warrendale: IEEE) **3** p. 151