

1906
D64

DIXON & HELLMANN

The Design and Construction
of a High-Tension Transformer

Electrical Engineering

BS

1906

UNIVERSITY OF ILLINOIS
LIBRARY

Class

1906

Book

D67

Volume

Je 08-10M



28
200

THE DESIGN AND CONSTRUCTION OF A HIGH-TENSION TRANSFORMER

BY

FRANK EUGENE DIXON
CARL AUGUST HELLMANN

THESIS

For the Degree of Bachelor of Science
in Electrical Engineering

COLLEGE OF ENGINEERING
UNIVERSITY OF ILLINOIS

PRESENTED, JUNE, 1906



Digitized by the Internet Archive
in 2013

<http://archive.org/details/designconstructi00dixo>

1906
DG4

UNIVERSITY OF ILLINOIS

June 1, 1906

THIS IS TO CERTIFY THAT THE THESIS PREPARED UNDER MY SUPERVISION BY

FRANK EUGENE DIXON and CARL AUGUST HELLMANN

ENTITLED DESIGN AND CONSTRUCTION OF A HIGH TENSION TRANSFORMER

IS APPROVED BY ME AS FULFILLING THIS PART OF THE REQUIREMENTS FOR THE DEGREE

OF Bachelor of Science in Electrical Engineering

Morgan Brooks

HEAD OF DEPARTMENT OF Electrical Engineering

1 Introductory

The present tendency in electrical transmission of energy over considerable distances is towards the use of extremely high voltages. Year after year we hear of the installation of higher and higher pressures. The great advantages and economies offered by high voltages are due to the fact that the weight of copper in the lines varies inversely as the square of the voltage used, for the same loss of power in transmission. This is a well-known fact - known long before the advent of high-tension systems - but only recently have steps been taken to realize its full possibilities and benefits. However, this increase of voltage can not go on indefinitely without reaching an upper limit, beyond which, the economies gained are more than offset by the difficulty of providing proper insulation and construction of the transmission line. At these extreme voltages a new source of loss appears, a discharge thru the air, resembling somewhat the silent discharge of a static machine, a beautiful but undesirable phenomenon. At high voltages this becomes a rather serious loss of energy. Another source of loss is leakage over the surface of the

2.

insulating supports.

In order to investigate these phenomena it was proposed to build a transformer which can take power from the University system, at 440 volts, and step up to 100,000 volts. A transformer of this kind necessarily differs very materially from ordinary commercial transformers, working at one or two thousand volts, and the difficulties will be seen and many peculiarities noticed on examining the following details of its design.

3.

General Description.

The transformer designed for this purpose is rated as follows:

{ 440 volts to 100,000 volts.
10,000 Watts at full load.
60 Cycles.

The core type of construction was decided upon, the core containing three hundred and seventy-five pounds of the best transformer iron. The extreme dimensions of the core are thirty-one inches by nineteen inches. In order to economize space and copper, the shape of the cross-section of the core limbs is made to approach as nearly as possible, without too much complexity, to a circle. To do this, three different widths of iron are used, arranged as shown in the accompanying drawing. The area of section thus obtained is fifteen and one-half square inches for the limbs and twenty square inches for the yokes. The total flux necessary is one million lines of force, hence the maximum flux density is sixty-four thousand five-hundred lines per square inch in the limbs, and fifty thousand lines per square inch in the yokes.

The low-tension winding, designed for four hundred and forty volts, has a total of one hundred and sixty-six turns of number eight B.&S. double cotton covered wire. This weighs about fourteen pounds.

The core is prepared for winding by wrapping it tightly with a layer of three-sixteenth inch rope and then covering this with two layers of heavy cloth.

The one-hundred thousand volt coil consists of thirty-eight thousand four hundred turns of number thirty B.&S. double cotton covered wire and is wound in ninety-six sections each giving about one thousand and forty volts. These coils were wound on a former and slipped on a fiber cylinder, and are separated from adjacent coils by circular rings of fiber one sixteenth of an inch thick. Each coil contains four hundred turns and has an inside diameter of nine and one-quarter inches, a depth of about three-quarters of an inch, and a thickness of one-quarter of an inch.

The insulation between the primary and secondary coils consists of a thickness of one and one-half inches of good kerosene oil.

The whole is contained in a galvanized

iron tank, enclosed in a strong wooden case. The tank is three feet long, two feet wide and three and one-half feet high.

The tank is covered with a plate of glass, the low tension terminals passing out directly thru holes drilled in the glass, and the high tension terminal being brought out thru heavy glass tubes passing thru the glass cover and into the oil.

About one hundred and forty gallons of kerosene oil are required to properly cover the transformer in this tank.

These precautions in regard to insulation are of vital importance, because the voltage it withstands, namely one hundred kilo-volts, can break down a gap of ten inches of dry air.

The Design of the Transformer.

As mentioned before, the designing of this apparatus is very different from that of commercial transformers. The essential point of difference is that in a commercial transformer different points are considered than in one to be used for experimental work. High all-day efficiency, low iron loss, close regulation, cheapness, all these are items of importance in commercial transformers. However, if a transformer is to be used only a few hours at a time, and perhaps not at all for several months in a year, the requirements, while on the whole the same, are nevertheless of widely different relative importance. Close regulation, low core-loss, and efficiency, are sacrificed to a considerable extent in order to secure cheapness, high insulation, and ease of construction. By using a high flux density the number of turns of wire is correspondingly decreased, and better insulation is made possible.

The fundamental formula

$$B_{max} = \frac{E}{T} \times \frac{10^8}{1.4 \pi f A}$$

was used to get the proportions of the

7.

transformer. This formula is given, in a different form on page 149 of "Alternating Currents" by Franklin and Williamson. Here $\frac{E}{T}$ is the volts given by a single turn of wire, f is the frequency, A the area of the core in square inches, and B_{max} the maximum value of the flux-density, in lines per square inch. B_{max} was made 64,500 lines per square inch, that is, about fifty percent more than good practice dictates for an ordinary transformer of the same output. After considering various values, $\frac{E}{T}$ was finally taken as 2.64 and from these data A was found to be 15.5 square inches. This gives a core nearly 5.5 inches in diameter, built up of three widths of stampings, as mentioned before. This is increased to about six inches by the cloth and rope used to cover the limbs of the core.

The number of turns in the 440 volt coil is

$$\frac{440}{2.64} = 166 \text{ turns.}$$

that is, the voltage \div "volts per turn"
The current carried by this coil is,
at full load

8.

$$\frac{11000 \text{ Watts}}{440 \text{ Volts}} = 25 \text{ amperes}$$

This assumes 90% efficiency, and is approximate.

Since the transformer will not be used continuously, a rather high current density of 650 circular mils per ampere is permissible. This gives 16,500 circular mils hence a #8 B. & S. wire. This is wound in a single layer on each limb, the total length being

$$\pi \times 6" \times 166 \div 12 = 260 \text{ feet.}$$

The theoretical number of turns in the high-tension coil is

$$\frac{100,000}{2.64} = 37,900 \text{ turns,}$$

but as will be seen later, a larger number is necessary. The current in this coil is

$$\frac{10,000 \text{ Watts}}{100,000 \text{ Volts}} = \frac{1}{10} \text{ ampere.}$$

Allowing 1000 circular mils per ampere, this gives a #30 B & S wire.

Allowing an inch and a half for oil between the two windings, we get $9\frac{1}{4}"$ for the internal diameter of this coil. To avoid an excessive voltage

9.

between adjacent layers, the coil was made in 96 sections, separated from each other by fiber rings, $\frac{1}{16}$ " thick, arranged on four bobbins, each bobbin containing 24 sections of 400 turns each. The mean length of a turn is

$$\pi \times 10" \div 12 = 2.62 \text{ feet}$$

Hence the total length of this wire is

$$38400 \times 2.62' = 100,500'$$

nearly nineteen miles.

The increase in the number of turns from 37,900 to 38,400 is to allow for the leakage and the IR drop of both coils.

The total volume of iron in the core is

$$15.5 \times 21 \times 2 + 20 \times 19 \times 2 = 1400 \text{ cu. in.}$$

or $1400 \div 3.33 = 375$ pounds. The iron used is 12 mils thick.

10.

Losses and Efficiency.

The sources of loss of energy are

$$\text{Losses} \left\{ \begin{array}{l} \text{Iron Loss} \left\{ \begin{array}{l} \text{Hysteresis} = W_h \\ \text{Eddy Current} = W_e \end{array} \right. \\ \text{Copper Loss} \left\{ \begin{array}{l} \text{Primary} = W_p \\ \text{Secondary} = W_s \end{array} \right. \end{array} \right.$$

The losses of pressure are as follows

$$\text{Drop} \left\{ \begin{array}{l} \text{Primary IR drop} \\ \text{Secondary IR drop} \\ \text{Seakage drop} \end{array} \right.$$

The IR drop in the 440 volt coil at a temperature of 50°C is

$$IR = 275' \times 0.000,701 \times 25 = 4.81 \text{ volts at full load.}$$

For the other coil we have

$$R = 100,500' \times .115 = 11600 \text{ ohms and}$$

$$IR = 11600 \times 0.1 = 1160 \text{ volts.}$$

The leakage drop is calculated from a formula due to Kapp

$$E_L = K \left[\frac{NI}{\Phi} \times \left(\frac{b}{2} + \frac{a}{3} \right) \times \frac{l}{h} \times E_s \right]$$

where N = turns in fine-wire coil, I =

11.

current in that coil, Φ = total flux, b = distance between primary and secondary coils, from copper to copper, a = mean depth of (primary + secondary) windings, h = length of winding space, l = perimeter of air gap between primary and secondary [i.e. "oil space" in this case], and K a constant depending upon the type of transformer. The value of K is 5 for a core type transformer having a concentric primary and secondary on each limb. All measurements are in inches. Hence

$$E_L = 5 \times \frac{38,700 \times 0.1}{1,000,000} \times \left(\frac{1.5}{2} + \frac{.36}{3} \right) \frac{24}{36} \times 100,000$$

$$E_L = 1100 \text{ volts at full load.}$$

The iron losses:-

Hysteresis: The formula for hysteresis loss is

$$W_h = \eta f V B_{max}^{1.6} \times 10^{-7} \text{ Watts,}$$

where η = hysteresis constant whose value is 0.003 in this case. V = volume of iron in cubic inches. Hence

$$W_h = 0.003 \times 60 \times 1400 \times 49,500,000 \times 10^{-7} \text{ Watts}$$

12.

$$\therefore W_h = 1250 \text{ Watts}$$

Eddy Current Loss:

$$W_e = b v t^2 f^2 B_{\max}^2 \times 10^{-7} \text{ Watts}$$

where b is a constant whose value is 0.0004 for the iron used, and t = thickness of laminations in inches = 0.012.

$$\text{Hence, } W_e = .0004 \times 1400 \times .012^2 \times 60^2 \times 64,500^2 \times 10^{-7} = 121 \text{ Watts.}$$

The I^2R loss in the 440 volt coil is
 $W_p = 25^2 \times 1.92 = 120 \text{ watts at full load}$

The I^2R loss in the 100,000 volt coil is
 $W_s = 0.1^2 \times 11600 = 116 \text{ watts at full load}$

$$\text{The efficiency} = \frac{\text{OUTPUT}}{\text{INPUT}} = \frac{W}{W + W_h + W_e + W_p + W_s}$$

$$\text{Eff} = \frac{10000 \times 100\%}{10000 + 1250 + 121 + 120 + 116} = 86\% \text{ at}$$

full load.

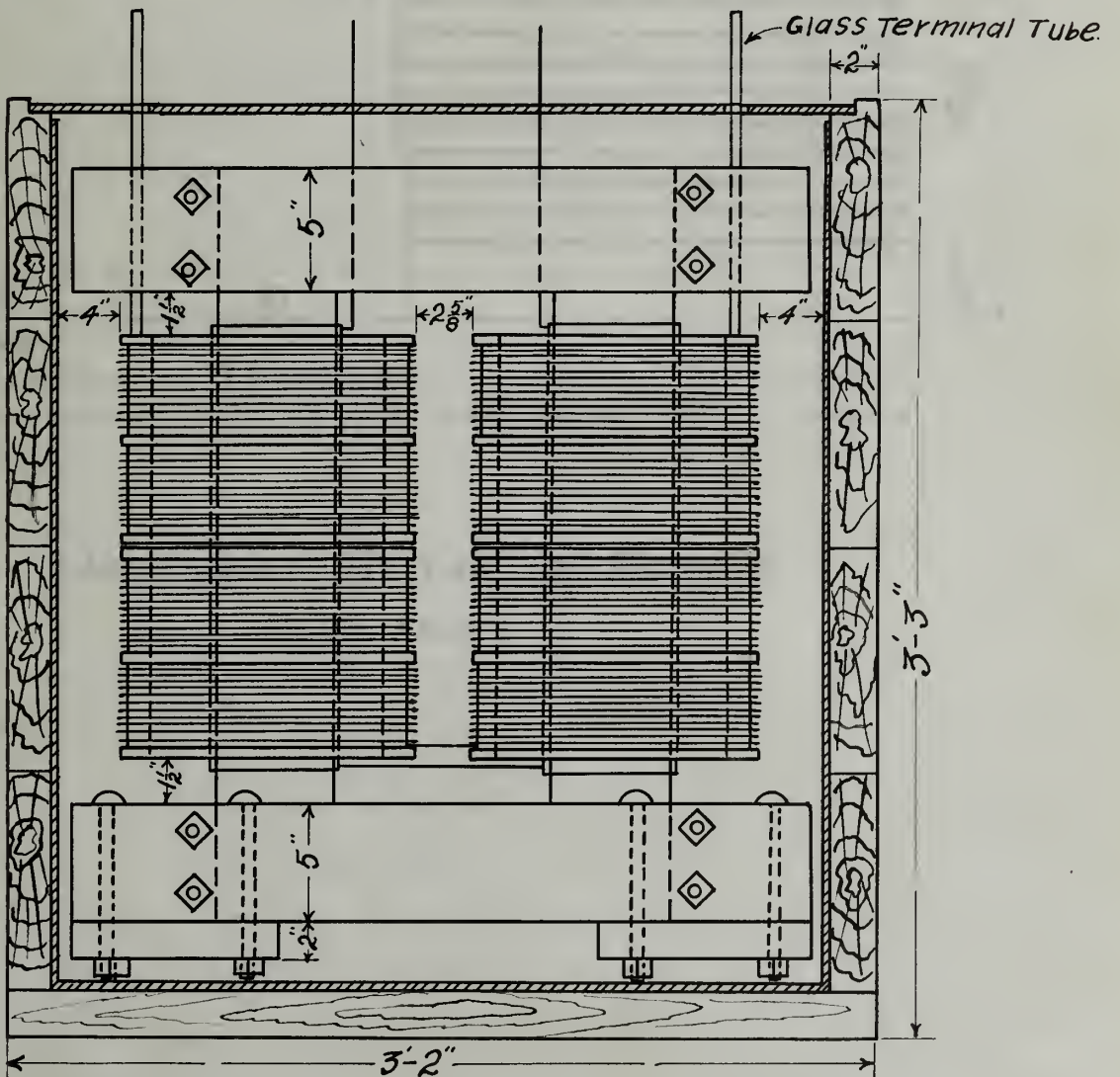
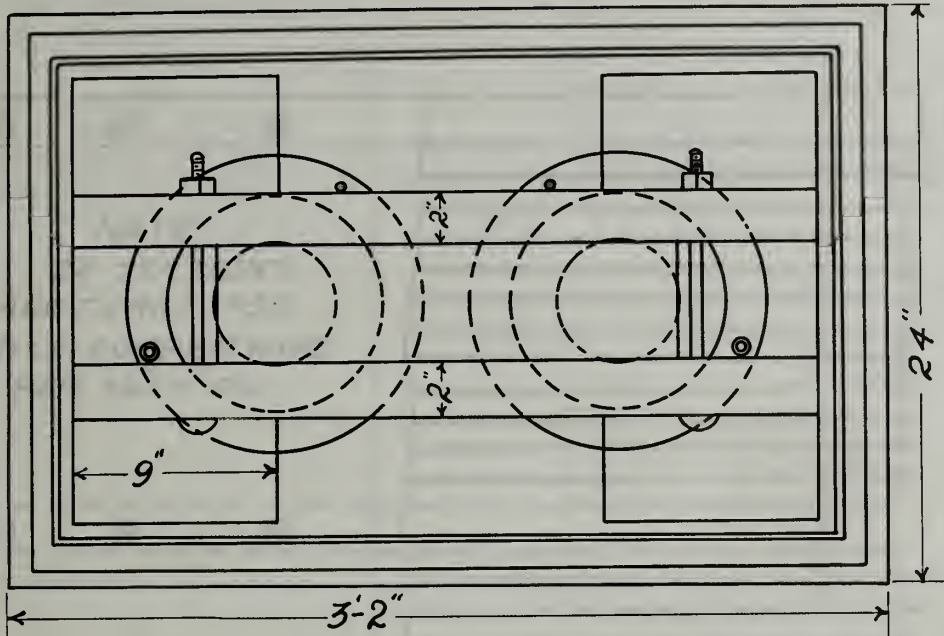

TRANSFORMER AND TANK.
 1/8 FULL SIZE.

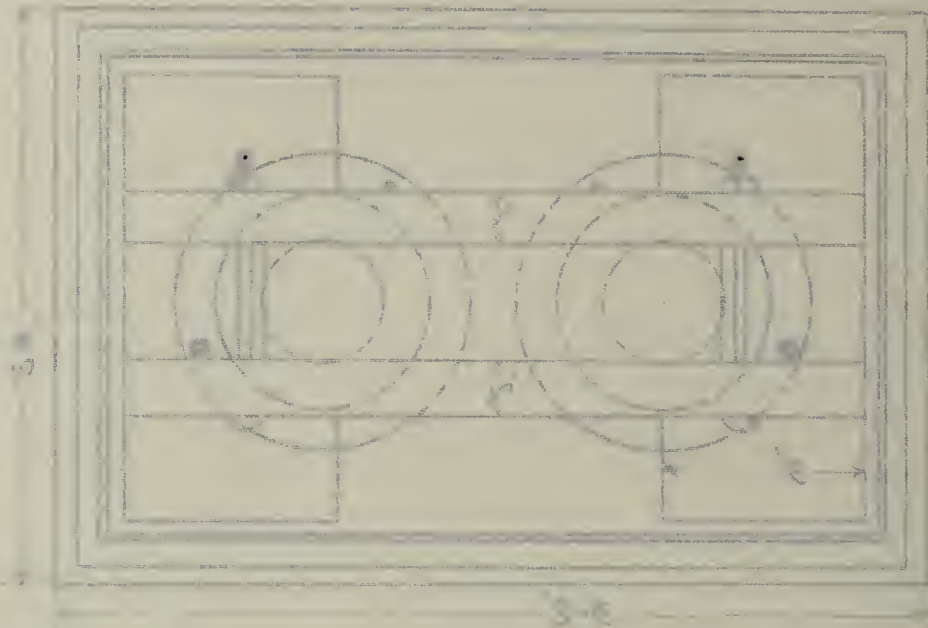

PLAN OF ROOM NO. 104

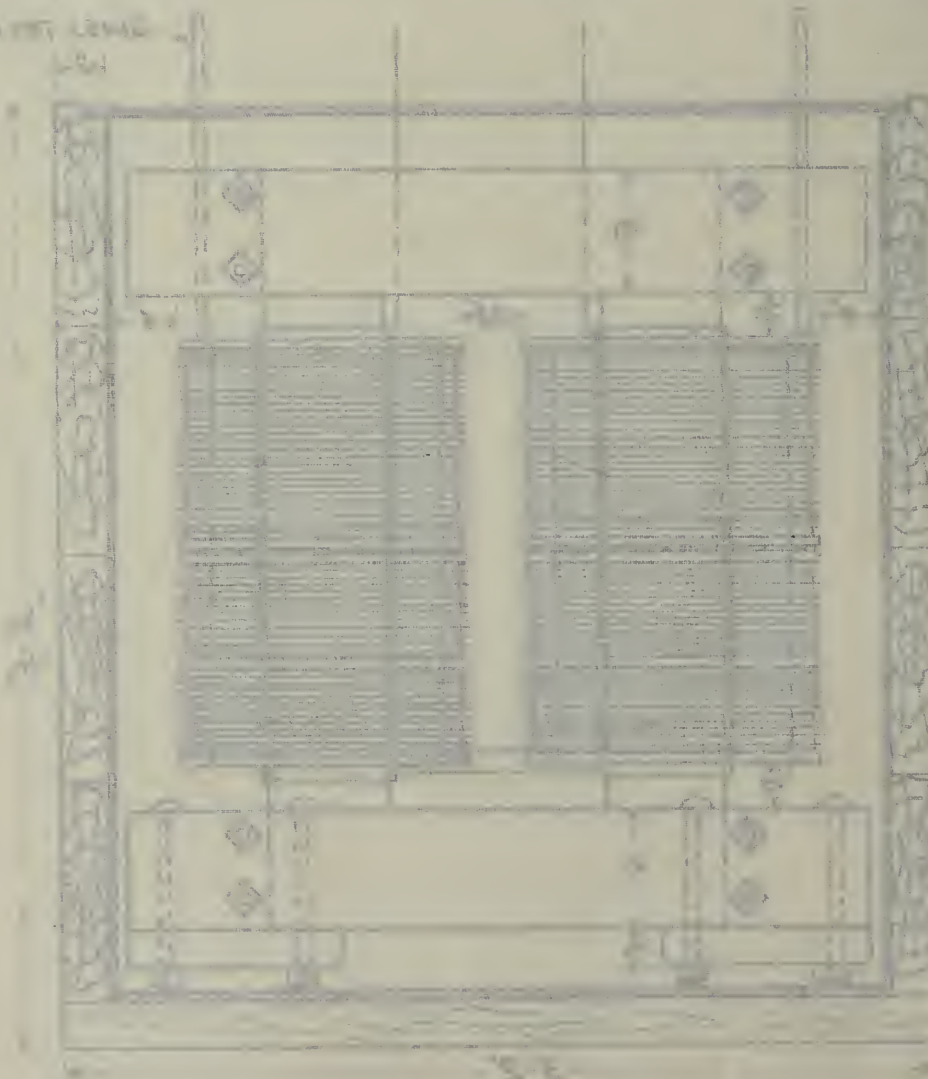

PLAN OF ROOM NO. 105

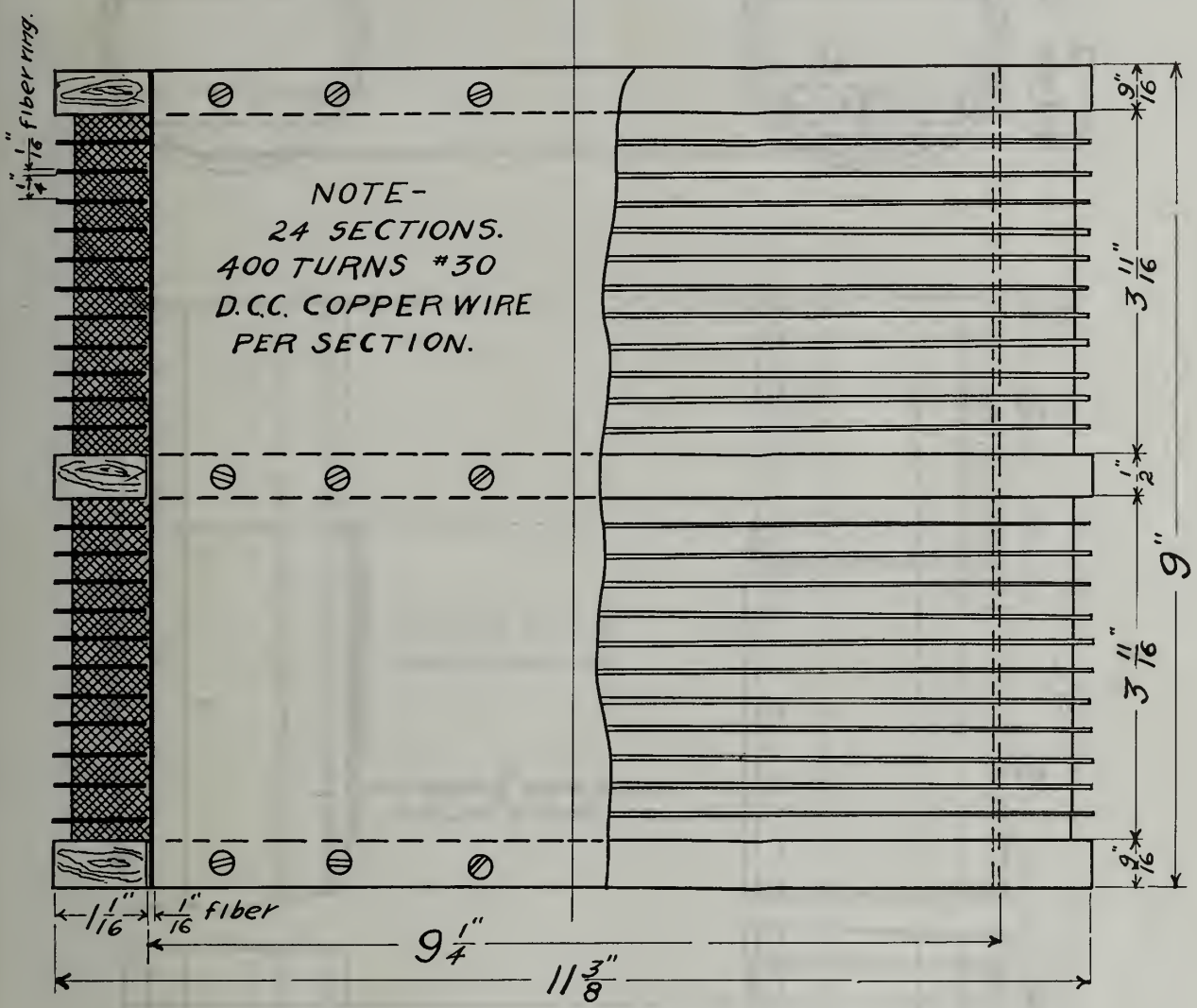

HALF SIZE DETAIL OF BOBBIN.
(MAKE FOUR.)



SHIP HULL DETAIL IN BOW
(Front view)

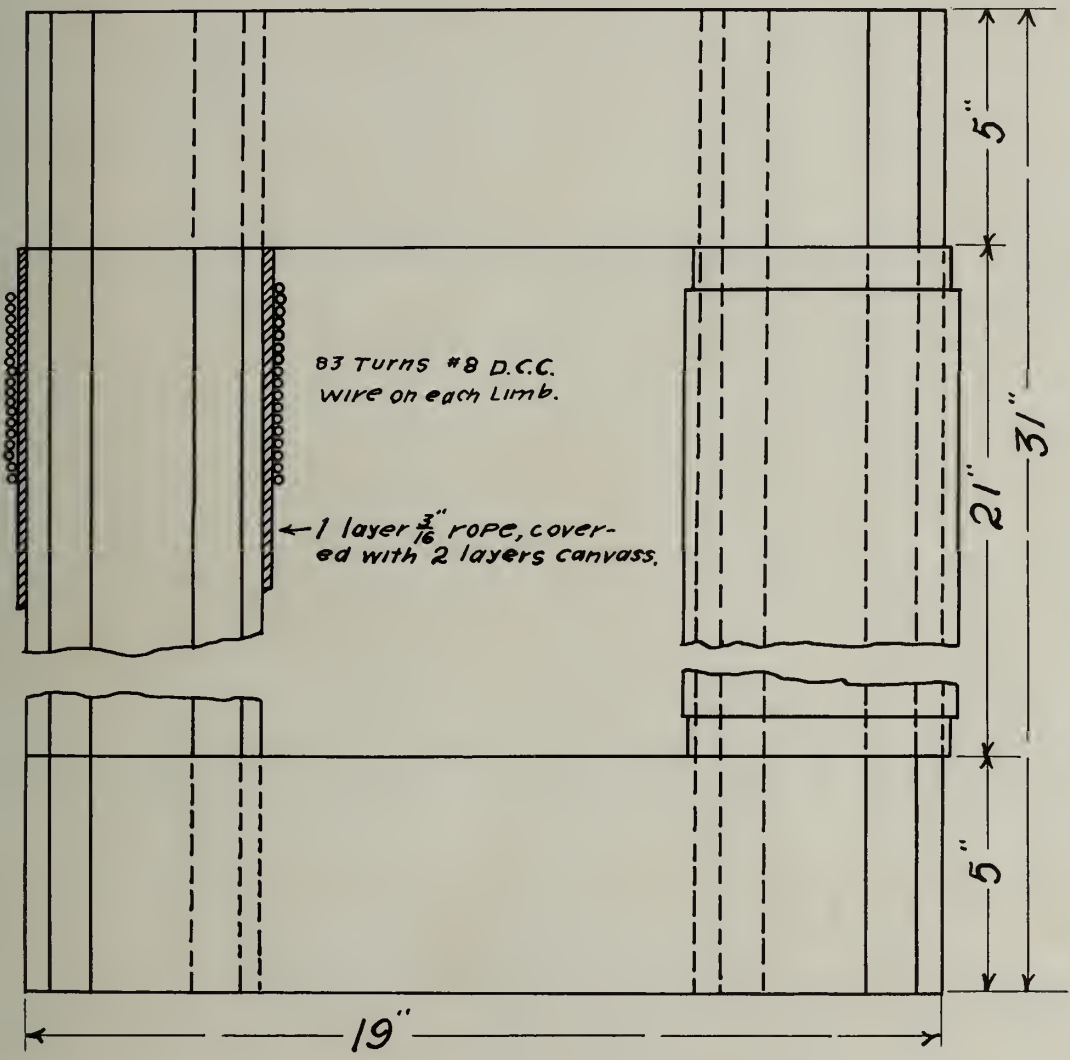
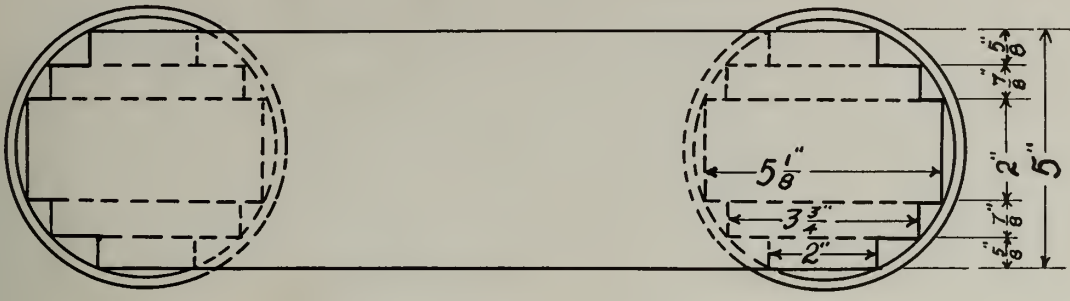

CORE
 $\frac{1}{4}$ FULL SIZE.



3 FT DISC
 2 FT 2

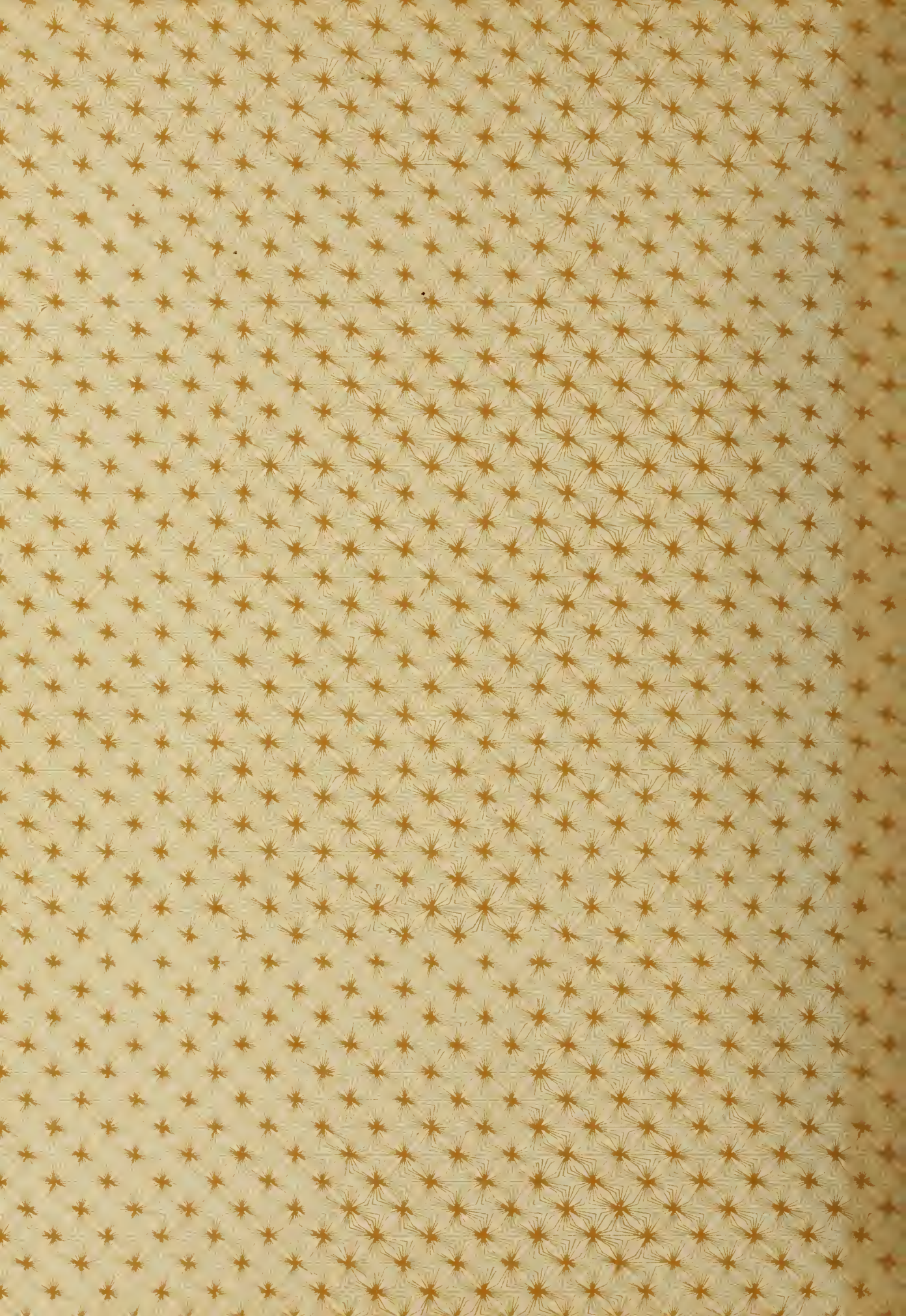

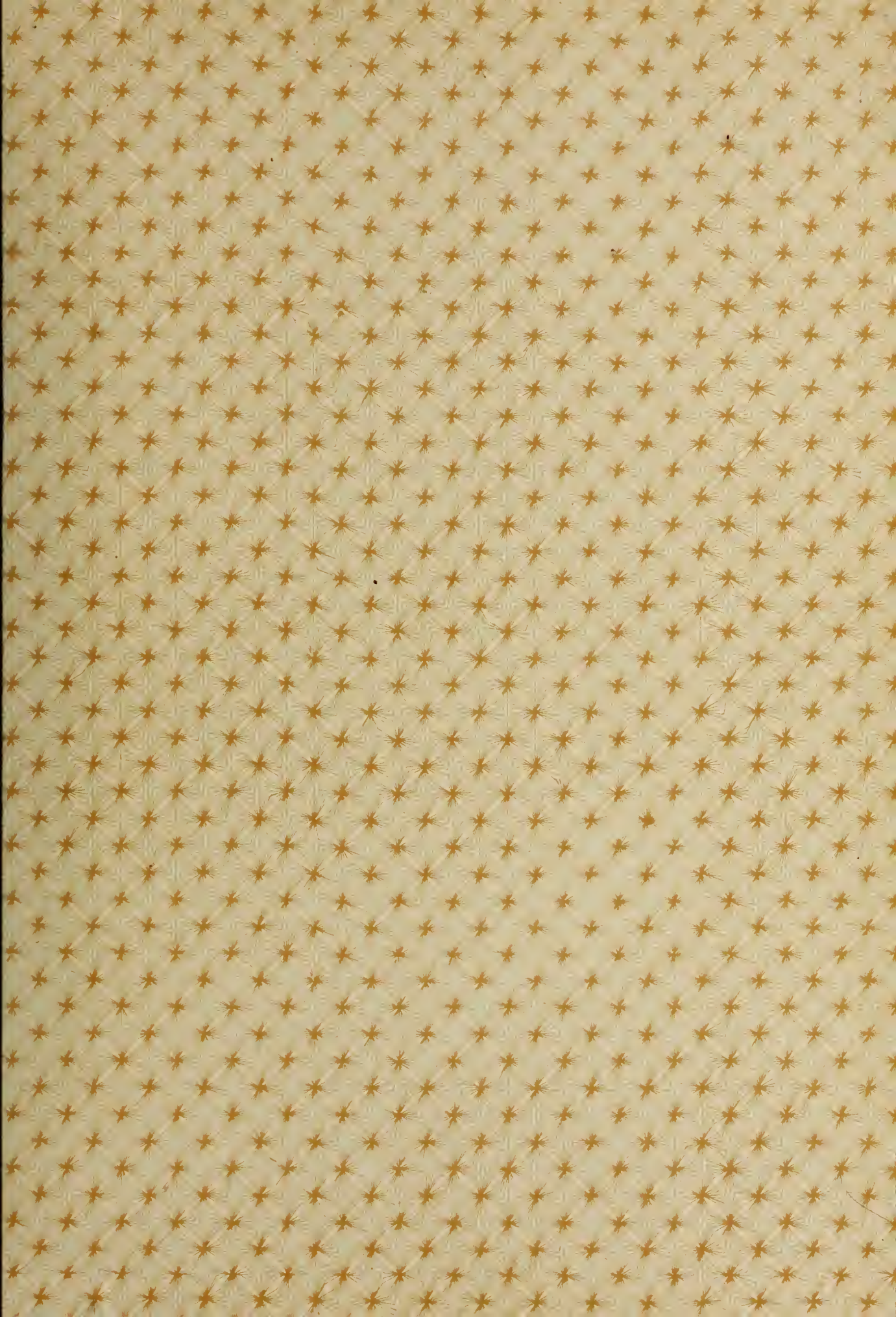

UNIVERSITY OF ILLINOIS-URBANA



3 0112 082195451