

3100098009981

6555

# TUGAS AKHIR (OE 1701)

## STUDI EKSPERIMENTAL PENENTUAN KOEFISIEN REDAMAN PADA SUATU MODEL SEMISUBMERSIBLE AKIBAT GERAKAN SURGING

RSke  
627.98  
Adi  
S-1  

---

1997



Disusun Oleh :

**ADI WIRAWAN HUSODO**

**NRP : 4392100007**

PADA...	
Tgl. Br...	1/9 97
No. Agenda Exp.	9399

**JURUSAN TEKNIK KELAUTAN  
FAKULTAS TEKNOLOGI KELAUTAN  
INSTITUT TEKNOLOGI SEPULUH NOPEMBER  
SURABAYA  
1997**



**STUDI EKSPERIMENTAL PENENTUAN KOEFISIEN  
REDAMAN PADA SUATU MODEL SEMISUBMERSIBLE  
AKIBAT GERAKAN SURGING**

**TUGAS AKHIR**

**Diajukan Guna Memenuhi Salah Satu Syarat  
Untuk Menyelesaikan Studi Program Sarjana**

**Pada**

**Jurusan Teknik Kelautan**

**Fakultas Teknologi Kelautan**

**Institut Teknologi Sepuluh Nopember**

**Surabaya**

**Mengetahui / Menyetujui :**

**Pembimbing I**

**Pembimbing II**



**Jr. Mas Murtedjo, M. Eng**  
**NIP. 130 687 431**

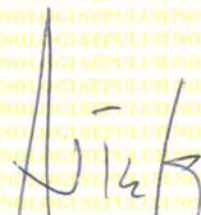

**Jr. Arief Suroso, M Sc**





**ABSTRAK**

**TUGAS AKHIR**

**JURUSAN TEKNIK KELAUTAN FTK-ITS**



## ABSTRAK

Penelitian ini mengenai studi eksperimental untuk mengetahui besarnya koefisien redaman pada suatu model semisubmersible dalam arah gerakan surgung yang dilakukan di Laboratorium Hidrodinamika ITS. Model yang digunakan terbuat dari bahan flexiglass dengan 6 buah silinder vertikal dan 2 buah silinder horisontal. Dalam penelitian ini menggunakan variasi sarat 6.5 cm, 11.0 cm, dan 22.4 cm, dengan rentang periode 1.2 - 2.0 dt, serta tinggi gelombang 2.0 dan 4.0 cm.

Keseluruhan hasil percobaan tersebut di atas selanjutnya dibandingkan dengan hasil perhitungan dengan menggunakan teori strip atau dengan beberapa penelitian lain mengenai gerakan surgung yang telah dipublikasikan.

Hasil perhitungan koefisien redaman dengan teori strip menunjukkan harga koefisien redaman pada sarat 6.5 cm dalam rentang 1.38 - 5.48 kg-dt/m, untuk sarat 11.0 cm berkisar antara 0.25 - 0.724 kg-dt/m, dan untuk sarat 22.4 cm berada dalam rentang 0.178 - 0.377 kg-dt/m.

Hasil percobaan pada kondisi sarat 6.5 cm dan tinggi gelombang 4 cm menunjukkan harga koefisien redaman berkisar antara 0.19 - 10.19 kg-dt/m. Sedangkan untuk tinggi gelombang 2 cm besaran koefisien redaman dalam rentang 0.27 - 0.76 kg-dt/m.

Hasil percobaan pada kondisi sarat 11.0 cm dan tinggi gelombang 4 cm menunjukkan harga koefisien redaman yang terjadi dalam rentang 0.2465 - 6.4714 kg-dt/m. Sedangkan untuk tinggi gelombang 2 cm besarnya koefisien redaman dalam rentang 0.2596 - 0.6123 kg-dt/m.

Hasil percobaan pada kondisi sarat 22.4 cm dan tinggi gelombang 4 cm menunjukkan harga koefisien redaman berkisar antara 1.5798 - 17.0989 kg-dt/m. Sedangkan untuk tinggi gelombang 2 cm berkisar antara 0.3 - 4.5116 kg-dt/m.

Hasil Percobaan pada sarat 6.5 cm secara kualitatif menunjukkan trend garis yang relatif sama dengan trend garis hasil perhitungan teori. Tetapi untuk sarat 11 cm dan 22.4 cm secara kualitatif terjadi perbedaan trend garis yang dihasilkan.





**KATA PENGANTAR**

**TUGAS AKHIR**

**JURUSAN TEKNIK KELAUTAN FTK-ITS**



## KATA PENGANTAR

Bismillahirrahmaanirrahiim,

Alhamdulillah segala puji dan syukur kehadirat Allah SWT karena atas kehendak Allah jualah penulis dapat menyelesaikan tugas akhir ini dengan judul **Studi Eksperimental Penentuan Koefisien Redaman Pada Suatu Model Semisubmersible Akibat Gerakan Surging.**

Penulis menyadari atas segala kekurangan dan kelemahannya sebagai manusia biasa, karenanya penulis ingin menyampaikan rasa terima kasih kepada semua pihak yang membantu dengan keikhlasannya dalam penyelesaian tugas akhir ini. Rasa terima kasih tersebut terutama kepada :

1. Ayah (alm) dan Ibu, serta Eyang dan saudara-saudaraku tercinta atas doa restunya dan atas segalanya.
2. Ir. Mas Murtedjo, M. Eng dan Ir. Arief Suroso, M. Sc, selaku dosen pembimbing yang dengan segala kesabaran dan ketulusannya dalam memberikan bimbingan, serta waktu dan tenaga yang diberikan.
3. Ir. Langgeng Condro, Pak Tony, Pak Joko, Mas Pur, dan Pak Yus di Laboratorium Hidrodinamika, atas segala bantuannya untuk tugas akhir ini.
4. Ir. Imam Rochani, M. Sc selaku dosen wali yang selalu memberikan pengarahan selama menempuh studi di T. Kelautan FTK-ITS.
5. Ir. Eko B. Djatmiko, M. Sc, Phd, selaku ketua jurusan T. kelautan beserta bapak-bapak dosen yang telah memberikan ilmu-ilmunya.
6. Arek-arek L-92, terutama Iman, Wasis, Yeyes, Bima, Dani, Taufik, Dasril, Dhodhot, dll. Terima kasih atas dorongannya selama ini, dan atas persahabatan yang terindah. We are the great team, man !!



7. Gang Lt. IV : mas Edi, mas Arinta atas bantuan rumus & journalnya, Momon, Iwan, Budiono, Budiasih, Vera, Ayik, Gering, dll. Spesial buat Ice dan Roni, semoga kita selalu sebagai saudara.
8. Teman-teman "**Hard Rock Ma'e**" : Deni, Wahyu, Nanux, Wika, Ipung, Anang, Budi, Pakde Hery, Bayu, Feri, Ma'e & Pa'e, dll.
9. Teman-teman W-Bike team : Suendro, Rusiadi, Momo, Harun, dll. Ayo rek kamu pasti bisa !!
10. Adik-adikku di T. Kelautan : Alfie, Hesti, Carchi, Heni, dll. Terima kasih atas segalanya.
11. Esthiana Rahayu atas segala yang terindah, terutama dukungan moralmu.
12. Teman-teman kost GK 32 : Erwin, wawan, Mbah Miftah, Andik, dll.
13. Pihak-pihak lain yang tidak sempat penulis sebutkan disini, dengan tanpa mengurangi rasa hormat.

Penulis menyadari bahwa tugas akhir ini jauh dari kesempurnaan, oleh sebab itu saran dan kritik untuk penyempurnaannya sangat diperlukan. Akhirnya semoga tugas akhir ini dapat memberikan manfaat kepada para pembaca sekalian.

Surabaya, Agustus 1997

Adi Wirawan Husodo





**DAFTAR ISI**

**TUGAS AKHIR**

**JURUSAN TEKNIK KELAUTAN FTK-ITS**



# DAFTAR ISI

LEMBAR JUDUL	i
LEMBAR PENGESAHAN	ii
ABSTRAK	iii
KATA PENGANTAR	iv
DAFTAR ISI	vi
DAFTAR TABEL	ix
DAFTAR GAMBAR	x
DAFTAR NOTASI	xii

## **BAB I. PENDAHULUAN**

1.1. Latar Belakang Masalah	I-1
1.2. Perumusan Masalah	I-4
1.3. Tujuan	I-4
1.4. Batasan Masalah	I-5
1.5. Metodologi dan Model Analisis	I-6
1.6. Sistematika Penulisan	I-8

## **BAB II. TINJAUAN PUSTAKA**

2.1. Gerakan Struktur Terapung	II-1
2.2. Sistem Satu Derajat Kebebasan	II-3
2.3. Teori Strip	II-9
2.4. Gaya-gaya yang bekerja pada Strip	II-10
2.4.1. Gaya Inersia	II-10
2.4.2. Gaya Redaman	II-13
2.4.3. Gaya Pengembali	II-17
2.5. Gaya Eksitasi	II-19
2.6. Beban dan Teori Gelombang	II-23



2.6.1. Beban Gelombang	II-23
2.6.2. Teori Gelombang	II-25
2.7. Region of Validity	II-26
2.8. Hukum Kesamaan	II-27
2.9. Penelitian-penelitian terhadap Koefisien Redaman	II-29

### **BAB III. METODOLOGI PENELITIAN**

3.1. Studi Literatur	III-1
3.2. Persiapan Percobaan	III-2
3.2.1. Persiapan Model Semisubmersible	III-2
3.2.2. Fasilitas dan Perangkat Eksperimen	III-5
3.2.3. Kalibrasi	III-12
3.2.3.1. Kalibrasi Gelombang	III-12
3.2.3.2. Kalibrasi Load Cell	III-13
3.2.3.3. Kalibrasi Displasemen Transduser	III-13
3.2.3.4. Kalibrasi Konstanta Pegas	III-15
3.3. Proses Percobaan	III-16
3.4. Analisa Data Hasil Percobaan	III-17
3.5. Pembuatan Laporan Akhir	III-19

### **BAB IV. ANALISA DAN PEMBAHASAN**

4.1. Hasil Perhitungan Teori Koefisien Redaman	IV-1
4.2. Hasil Percobaan	IV-3
4.2.1. Hasil Kalibrasi	IV-3
4.2.2. Pengolahan Data Hasil Percobaan	IV-7
4.2.3. Penentuan Koefisien Redaman Hasil Percobaan	IV-8
4.3. Pembahasan	IV-10
4.3.1. Pengaruh Frekwensi, Sarat, dan Tinggi Gelombang Terhadap Koefisien Redaman	IV-10
4.3.2. Perbandingan Hasil Percobaan Koefisien Redaman dengan Teori	IV-12
4.3.3. Pengaruh Bentuk Konfigurasi T Terhadap	



**BAB V. KESIMPULAN DAN SARAN**

5.1. Kesimpulan

V-1

5.2. Saran

V-2

**DAFTAR PUSTAKA**

**DAFTAR LAMPIRAN**

Lampiran A : Penentuan Parameter Gelombang

Lampiran B1: Data Hasil Percobaan

Lampiran B2: Grafik Gaya, Tinggi Gelombang, dan  
Simpangan

Lampiran C : Perhitungan Teori Strip Koefisien Redaman

Lampiran D : Gaya Eksitasi Gelombang

Lampiran E : Kalibrasi

Lampiran F : Pengolahan Data Hasil Percobaan

Lampiran G : Grafik Koefisien Redaman Percobaan

Lampiran H : Photo Percobaan





**DAFTAR TABEL**

**TUGAS AKHIR**

JURUSAN TEKNIK KELAUTAN FTK-IITS



## DAFTAR TABEL

Tabel 3.1. Perbandingan Dimensi semisubmersible dan Model	III-4
Tabel 4.1. Resume Hasil Koefisien Redaman Teori Strip	IV-1
Tabel 4.2. Hasil Kalibrasi Beban pada Load Cell	IV-4
Tabel 4.3. Hasil Kalibrasi pada Trimmeter	IV-5
Tabel 4.4. Hasil Kalibrasi Gelombang	IV-6
Tabel 4.5. Hasil Kalibrasi Pegas	IV-7
Tabel 4.6. Resume Koefisien Redaman Percobaan Sarat 6.5 cm	IV-8
Tabel 4.7. Resume Koefisien Redaman Percobaan Sarat 11 cm	IV-9
Tabel 4.8. Resume Koefisien Redaman Percobaan Sarat 22.4 cm	IV-9





**DAFTAR GAMBAR**

**TUGAS AKHIR**  
**JURUSAN TEKNIK KELAUTAN FTK-ITS**



## DAFTAR GAMBAR

Gambar 1.1.	Bentuk dan Geometri Bangunan Semisubmersible	I-2
Gambar 2.1.	Enam Derajat Kebebasan Gerakan Struktur Terapung	II-1
Gambar 2.2.	Gaya Linier Tereadam dari Sistem Massa Pegas	II-4
Gambar 2.3.	Osilasi Bebas Tereadam $\zeta < 1.0$	II-7
Gambar 2.4.	Poligon Vektor Gaya	II-8
Gambar 2.5.	Penyelesaian Gaya Linier dari Sistem Massa Pegas	II-9
Gambar 2.6.	Teori Strip pada semisubmersible	II-10
Gambar 2.7.	Pengaruh Gerakan Benda terhadap Fluida	II-11
Gambar 2.8.	Distribusi Tekanan pada Benda dipercepat	II-12
Gambar 2.9.	Grafik rasio Amplitudo Gerakan Heaving	II-16
Gambar 2.10a.	Faktor Redaman Tiga Dimensi Gerakan Heaving	II-17
Gambar 2.10b.	Skema Hubungan Gaya Reaksi ( $F_r$ ) dan Gaya Luar ( $F_e$ )	II-18
Gambar 2.11.	Dimensi Model Semisubmersible	II-21
Gambar 2.12.	Profil Gelombang	II-25
Gambar 2.13.	Region Of Validity Chakrabarti, S. K	II-27
Gambar 2.14.	Koefisien Redaman Gerakan Surging pada Kapal Tanker 250 KDWT J. E. W. Wichers	II-30
Gambar 2.15.	Konfigurasi Silinder Gabungan Mikkelsen, J. & Calisal, S. M (1993)	II-30
Gambar 2.16.	Grafik Koefisien Redaman Gerakan Surging Silinder Gabungan Sarat 87 cm, Mikkelsen, J. & Calisal, S. M. (1993)	II-30
Gambar 2.17.	Grafik Koefisien Redaman Gerakan Surging Silinder Gabungan Sarat 94 cm, Mikkelsen, J.	



	& calisal, S. M. (1993).	II-31
Gambar 2.18.	Barge Segiempat J. P. Hooft (1982)	II-32
Gambar 2.19.	Grafik Koefisien Redaman Barge Segiempat J. P. Hooft (1982)	II-32
Gambar 2.20.	Circular Platform J. P. Hooft (1982)	II-33
Gambar 2.21.	Grafik Koefisien Redaman Surging Circular Platform J. P. Hooft (1982)	II-33
Gambar 3.1.	Dimensi Model Semisubmersible	III-2
Gambar 3.2.	Setting Alat Pemegang dan Pengarah	III-3
Gambar 3.3.	Setting Model dan Peralatan Pengukur	III-3
Gambar 3.4.	Kereta dan Perlengkapannya	III-5
Gambar 3.5.	Skema Rangkaian Model dan Peralatan Percobaan	III-11
Gambar 3.6.	Beda Fase antara Simpangan, Kecepatan, dan Percepatan	III-18
Gambar 4.1.	Grafik Koefisien Redaman Teori Strip Kondisi Sarat 6.5 cm	IV-2
Gambar 4.2.	Grafik Koefisien Redaman Kondisi Sarat 11 cm	IV-2
Gambar 4.3.	Grafik Koefisien Redaman Kondisi Sarat 22.4 cm	IV-3
Gambar 4.4.	Grafik b Percobaan Kondisi Sarat 6.5 cm	IV-10
Gambar 4.5.	Grafik b Percobaan Kondisi Sarat 11 cm	IV-11
Gambar 4.6.	Grafik b Percobaan Kondisi Sarat 22.4 cm	IV-12
Gambar 4.7.	Perbandingan Koefisien Redaman Hasil Percobaan Versus Koefisien Redaman Teori Strip Kondisi Sarat 6.5 cm	IV-13
Gambar 4.8.	Perbandingan Koefisien Redaman Hasil Percobaan Versus Koefisien Redaman Teori Strip Kondisi Sarat 11 cm	IV-13
Gambar 4.9.	Perbandingan Koefisien Redaman Hasil Percobaan Versus Koefisien Redaman Teori Strip Kondisi Sarat 22.4 cm	IV-14





**DAFTAR NOTASI**

**TUGAS AKHIR**  
JURUSAN TEKNIK KELAUTAN FTK-ITS



## DAFTAR NOTASI

$a$	: Added virtual mass
$a_x$	: Percepatan horisontal
$a_y$	: Percepatan vertikal
$A_z$	: Rasio amplitudo gerakan Heaving
$\beta$	: Sudut fase antara gerakan struktur dan gaya luar
$B_m$	: Lebar model
$B_n$	: Luas permukaan garis air
$\beta_n$	: Koefisien luasan strip ( $= S_n / (B_n \times T_n)$ )
$b_n$	: Koefisien redaman strip
$C_z$	: Faktore redaman tiga dimensi Heaving
$d$	: Kedalaman perairan
$f$	: Fraksional faktor hasil
$F_a$	: Gaya inersia
$F_b$	: Gaya redaman
$F_c$	: Gaya pengembali
$F_o$	: Amplitudo gaya eksitasi
$F_x$	: Gaya eksitasi
$g$	: Percepatan gravitasi = $9.81 \text{ m/dt}^2$
$H$	: Tinggi gelombang
$K$	: Koefisien pengembali (konstanta pegas)
$k$	: Angka gelombang
$\lambda$	: Panjang gelombang
$M$	: Massa struktur (Kg)
$m$	: Massa tambah (Kg)
$N_z$	: Total gaya redaman heaving
$\rho$	: Massa jenis fluida (air tawar = $1000 \text{ Kg/m}^3$ )
$S_n$	: Luasan melintang strip ( $\text{m}^2$ )
$T$	: Periode (Hz)



- $T_m$  : Tinggi model
- $T_n$  : Sarat perhitungan
- $u$  : Kecepatan horisontal gelombang
- $v$  : Kecepatan vertikal gelombang
- $W$  : Kerja (daya)
- $\omega$  : Frekwensi gelombang (rad/dt)
- $\omega_e$  : Frekwensi encountering
- $\omega_n$  : Frekwensi natural
- $x$  : Simpangan surging struktur
- $\dot{x}$  : Kecepatan surging struktur
- $\ddot{x}$  : Percepatan surging struktur



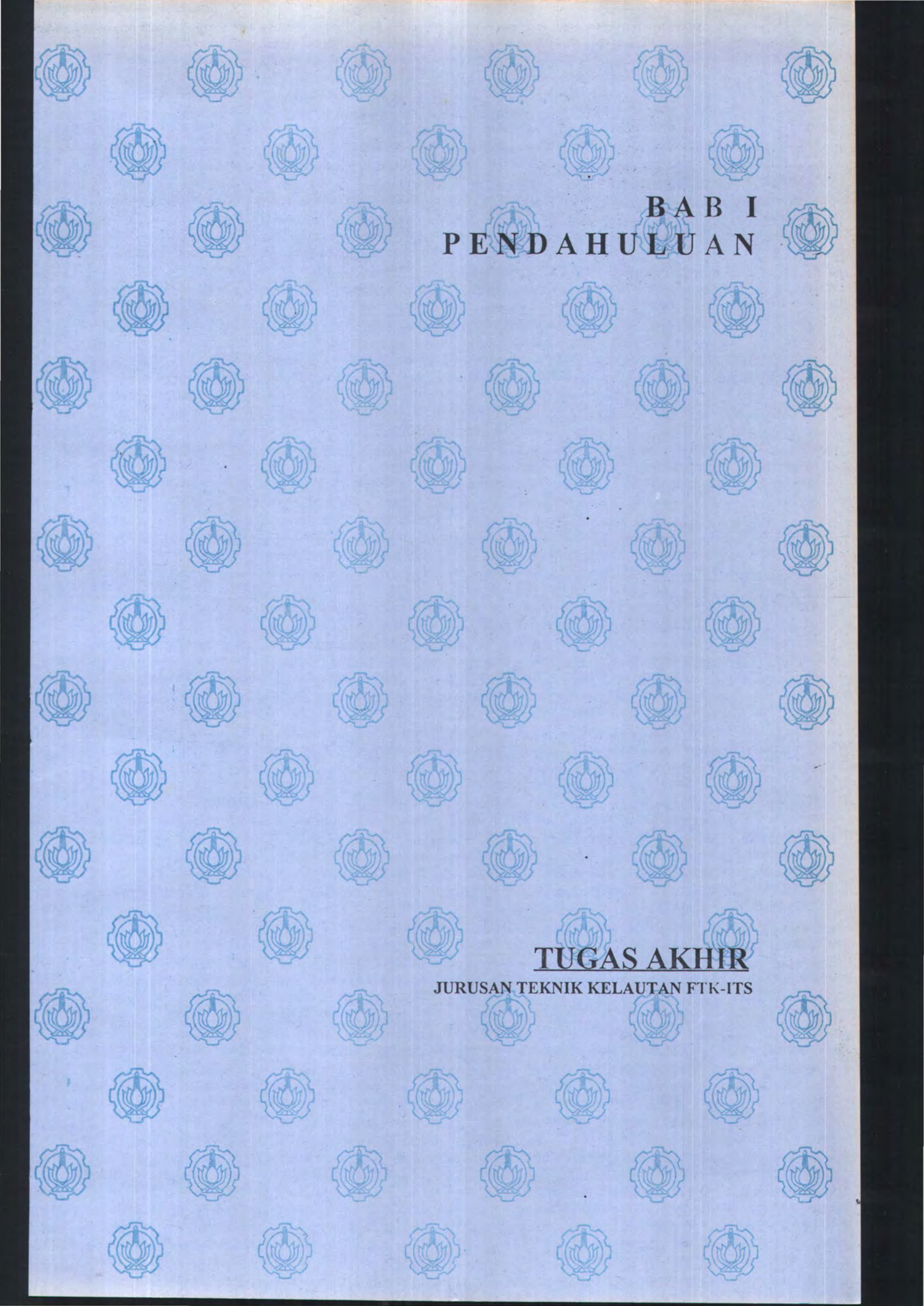

**BAB I**  
**PENDAHULUAN**

**TUGAS AKHIR**

**JURUSAN TEKNIK KELAUTAN FTK-ITS**



# BAB I

## PENDAHULUAN

### 1. 1. LATAR BELAKANG MASALAH

Didalam dunia eksplorasi minyak dan gas bumi di Indonesia, sementara ini masih banyak dilakukan di wilayah Indonesia Bagian Barat. Hal ini dikarenakan beberapa faktor seperti kondisi kedalaman perairan, kelengkapan sarana dan prasarana yang ada jika dibandingkan dengan wilayah Indonesia Bagian Timur. Faktor lain yang menyebabkan kegiatan eksplorasi di wilayah Indonesia Bagian Timur kurang menguntungkan adalah 86 % cekungan di Indonesia Bagian Timur dikategorikan sebagai cekungan laut dalam.

Untuk mengatasi berbagai hambatan di atas, maka perlu dilakukan pemilihan jenis dan sistem bangunan lepas pantai yang sesuai untuk kondisi laut dalam. Semisubmersible merupakan salah satu jenis sarana pokok yang sesuai untuk eksplorasi di perairan dalam. Pengertian laut dalam di Indonesia yaitu antara 200 sampai 500 meter. Pertimbangan digunakannya semisubmersible tersebut adalah karena semisubmersible merupakan kendaraan lepas pantai yang dapat berpindah-pindah (*offshore mobile units*), dan dalam pengoperasiannya memberikan karakteristik gerakan yang stabil. Hal ini disebabkan letak centre of buoyancynya jauh di bawah permukaan air. Sehingga secara ekonomis pengoperasiannya



dapat dikatakan lebih murah jika dibandingkan dengan tipe lainnya.

Secara umum bentuk dari struktur semisubmersible merupakan pengembangan dari bentuk kapal. Dimana bentuk umum dari suatu semisubmersible pada umumnya terdiri dari :

1. Dua buah kolom horisontal (pontoon).
2. Empat sampai delapan buah vertikal caisson (kolom).
3. Bracing (penegar) yang berguna untuk memberikan penambahan ketegaran dari struktur semisubmersible.
4. Bangunan atas (deck structure).

Bentuk tubular joint banyak digunakan dalam penyambungan antar elemen dari suatu semisubmersible, karena bentuk material yang digunakan pada umumnya berupa cylindrical hull (pipa tubular). Beberapa bentuk atau jenis dari semisubmersible dapat dilihat pada gambar 1.1 di bawah ini.

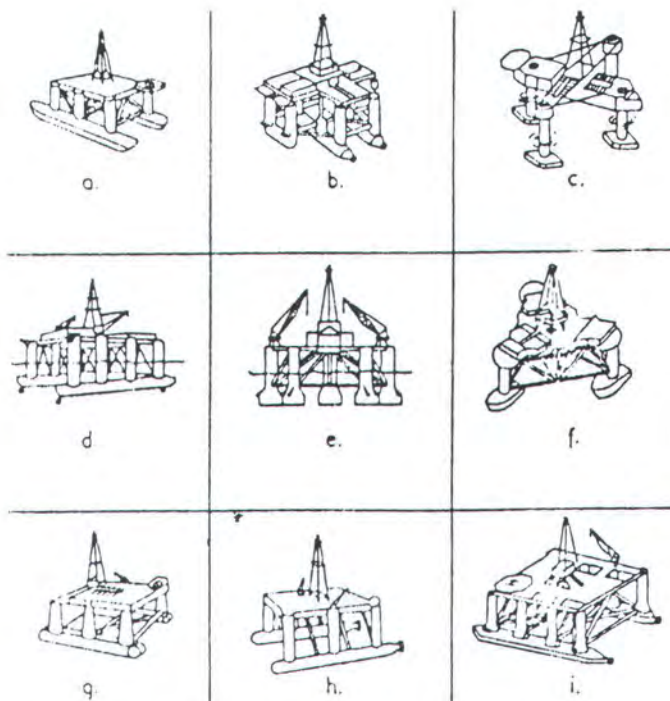

Gambar 1.1. Bentuk dan geometri bangunan semisubmersible

Beberapa aspek yang perlu dipertimbangkan dalam merencanakan semisubmersible platform, adalah sebagai berikut :

1. Pengaruh dari aksi gelombang selama umur operasinya.
2. Static stability.
3. Kapasitas untuk beban-beban yang bervariasi.
4. Kekuatan dari konstruksinya.
5. Luas dari deck yang digunakan untuk tempat kegiatan pengoperasian dan penyimpanan peralatan-peralatan.
6. Fasilitas penambatan.
7. Biaya pembuatan dan pengoperasiannya.

Untuk pembahasan selanjutnya akan ditinjau mengenai pengaruh aksi gelombang terhadap struktur semisubmersible. Karena pada semua struktur terapung termasuk semisubmersible yang beroperasi di perairan akan mengalami gerakan dalam arah enam derajat kebebasan, yaitu : surging, swaying, heaving, rolling, pitching, dan yawing, dimana semua gerakan di atas dapat mempengaruhi stabilitas dari pada bangunan apung tersebut. Yang pada akhirnya berpengaruh terhadap sistem penambatan yang akan digunakan.

Pada umumnya semua gerakan dari struktur terapung di dalam fluida akan mengalami gaya hidrodinamik. Gaya hidrodinamik tersebut akan bekerja apabila struktur terapung tersebut bergerak secara periodik baik di dalam maupun di permukaan air. Sedangkan gaya hidrodinamik yang bekerja ini akan dipengaruhi oleh besarnya koefisien massa tambah dan koefisien redaman yang ada. Koefisien ini harus diketahui lebih dahulu



sebelum analisa gerakan dilakukan.

Untuk menentukan besarnya koefisien redaman terhadap gerakan benda apung dalam enam derajat kebebasan secara keseluruhan sangat sulit dilakukan. Oleh sebab itu dalam memudahkan analisa, maka hanya dilakukan terhadap gerakan surging. Berangkat dari berbagai pertimbangan di atas dan melalui penelaahan awal dari studi literatur, dan juga pemanfaatan fasilitas Laboratorium Hidrodinamika F. T. Kelautan, maka judul yang dipilih untuk Tugas Akhir ini adalah :

***Studi Ekperimental Penentuan Koefisien Redaman Pada Suatu Model Semisubmersible Akibat Gerakan Surging***

## **1. 2. PERUMUSAN MASALAH**

1. Bagaimana pengaruh gelombang terhadap gerakan surging pada suatu model semisubmersible ?
2. Bagaimana pengaruh gerakan surging pada model semisubmersible dengan variasi sarat, frekwensi dan periode gelombang terhadap besarnya koefisien redaman ?
3. Apakah besarnya koefisien redaman model semisubmersibe hasil dari percobaan sesuai dengan hasil perhitungan teori ?

## **1. 3. TUJUAN**

Tujuan utama dari penulisan tugas akhir ini untuk mengetahui sejauh mana pengaruh gelombang terhadap gerakan surging pada suatu



model semisubmersible dalam penentuan koefisien redaman. Lebih jauh tugas akhir ini bertujuan untuk :

1. Menentukan besarnya koefisien redaman dari model semisubmersible akibat aksi gelombang dalam arah gerakan surging.
2. Mengetahui pengaruh perubahan sarat model, frekwensi, dan tinggi gelombang terhadap besarnya koefisien redaman.
3. Mengetahui besarnya perbedaan koefisien redaman hasil eksperimen dengan hasil perhitungan dengan teori strip.

#### **1. 4. BATASAN MASALAH**

Guna mempermudah pengerjaan dan penyelesaian tugas akhir ini, tanpa mengurangi bobot penelitian, maka perlu ditetapkan pembatasan masalah dan asumsi-asumsi sebagai berikut :

1. Gelombang yang digunakan dalam eksperimen adalah regular wave (linier) dengan arah datang gelombang dari depan (head sea) dengan menggunakan variasi frekwensi dan tinggi gelombang yang sesuai dengan kemampuan kolam uji Laboratorium Hidrodinamika FTK-ITS.
2. Gerakan yang terjadi dalam percobaan adalah gerakan surging murni.
3. Model semisubmersible dianggap beroperasi di perairan dalam.
4. Gesekan yang terjadi antara roda dengan rel dianggap kecil dan

dapat diabaikan.

5. Model dalam keadaan diam atau tanpa kecepatan, dan titik berat model berada di tengah-tengah dalam arah memanjang model.
6. Pegas yang dipakai sebagai pengembali dapat diasumsikan sebagai tali tambat dari semisubmersible saat beroperasi pada kondisi perairan yang sebenarnya.
7. Beban yang diperhitungkan hanya beban gelombang dengan bentuk sinusoidal.

## 1. 5. METODOLOGI DAN MODEL ANALISIS

Tugas akhir ini merupakan studi eksperimental yang dilakukan di laboratorium hidrodinamika FTK - ITS. Model yang digunakan berupa struktur semisubmersible yang terbuat dari bahan flexiglass, dan terdiri dari 2 (dua) silinder horisontal (pontoon) dan 6 (enam) silinder vertikal (kolom).

Untuk menjaga agar gerakan model selalu dalam arah surging, maka model dihubungkan dengan sepasang rel yang diberi roda dan diletakkan di atas. Untuk mengatur agar gerakan model dalam keadaan osilasi, maka pada model dipasang pegas sedemikian rupa dalam arah sejajar dengan sumbu x (memanjang) dengan nilai konstanta yang sesuai. Dimana pegas tersebut dapat dianggap mewakili sistem penambatan yang digunakan pada struktur yang sebenarnya.

Sebelum melakukan proses percobaan, maka terlebih dahulu



dilakukan proses kalibrasi pada semua peralatan yang akan digunakan. Model diuji di laboratorium dengan arah datang gelombang dari depan (head sea). Gelombang dibangkitkan dari pembangkit gelombang yang tersedia dan dipilih gelombang sinusiodal dengan input rentang frekwensi dan tinggi gelombang tertentu yang umum dijumpai di lapangan.

Pengukuran gaya total dilakukan dengan menggunakan load cell yang dipasang pada model sedemikian rupa sehingga pembacaan dapat dilakukan semudah mungkin. Gaya total tersebut baru dapat dihitung setelah dilakukan konversi dari regangan. Hal ini dikarenakan keluaran langsung dari eksperimen adalah berupa regangan.

Dalam menentukan besarnya simpangan, kecepatan, dan percepatan dapat diperoleh dari hasil eksperimen. Untuk menentukan besarnya simpangan yang terjadi dapat diketahui dari displacemen transducer. Sedangkan besarnya kecepatan dan percepatan dapat dilihat dari grafik strip chart. Dari gaya total dan simpangan yang terukur dari percobaan, kemudiaan dimasukkan ke dalam persamaan gerak sistem dinamis untuk menentukan besarnya koefisien redaman. Dalam percobaan ini akan digunakan tiga variasi sarat.

Hasil percobaan ini kemudian disusun secara sistematis dan dianalisa. Kemudian hasil dari percobaan ini dibandingkan dengan hasil perhitungan dengan menggunakan teori. Hasil dari percobaan maupun dari perhitungan disajikan dalam bentuk numerik dan grafik.

## 1. 6. SISTEMATIKA PENULISAN

Untuk menyelesaikan pembuatan tugas akhir ini, telah disusun sistematika penulisan sebagai berikut :

### Bab I. Pendahuluan

Diuraikan mengenai dasar pemikiran dan latar belakang yang melandasi penelitian ini, perumusan masalah dan tujuan yang hendak dicapai, batasan permasalahan serta metodologi penulisan.

### Bab II. Tinjauan Pustaka

Dalam bab ini diuraikan mengenai persamaan-persamaan yang digunakan dalam perhitungan, formulasi perhitungan koefisien massa tambah dan koefisien redaman secara teoritis, pemilihan teori gelombang yang sesuai dan hukum-hukum kesamaan dan penelitian-penelitian penentuan koefisien redaman struktur terapan dalam arah gerakan surging yang telah dipublikasikan.

### Bab III. Metodologi Penelitian

Berisi urutan langkah penyelesaian tugas akhir ini, mulai dari studi literatur, perhitungan teoritis, persiapan dan proses percobaan, analisa data sampai dengan penarikan kesimpulan hasil percobaan.

### Bab IV. Hasil dan Pembahasan

Dalam bab ini diuraikan mengenai perhitungan dan analisa data berikut grafik-grafiknya yang diperoleh dari percobaan, selain itu



disajikan pula beberapa perbandingan hasil percobaan dengan hasil pengujian sejenis yang telah dipublikasikan atau hasil perhitungan teoritis.

#### Bab V. Kesimpulan dan Saran

Berisi kesimpulan hasil percobaan dan saran-saran untuk penyempurnaan hasil percobaan.





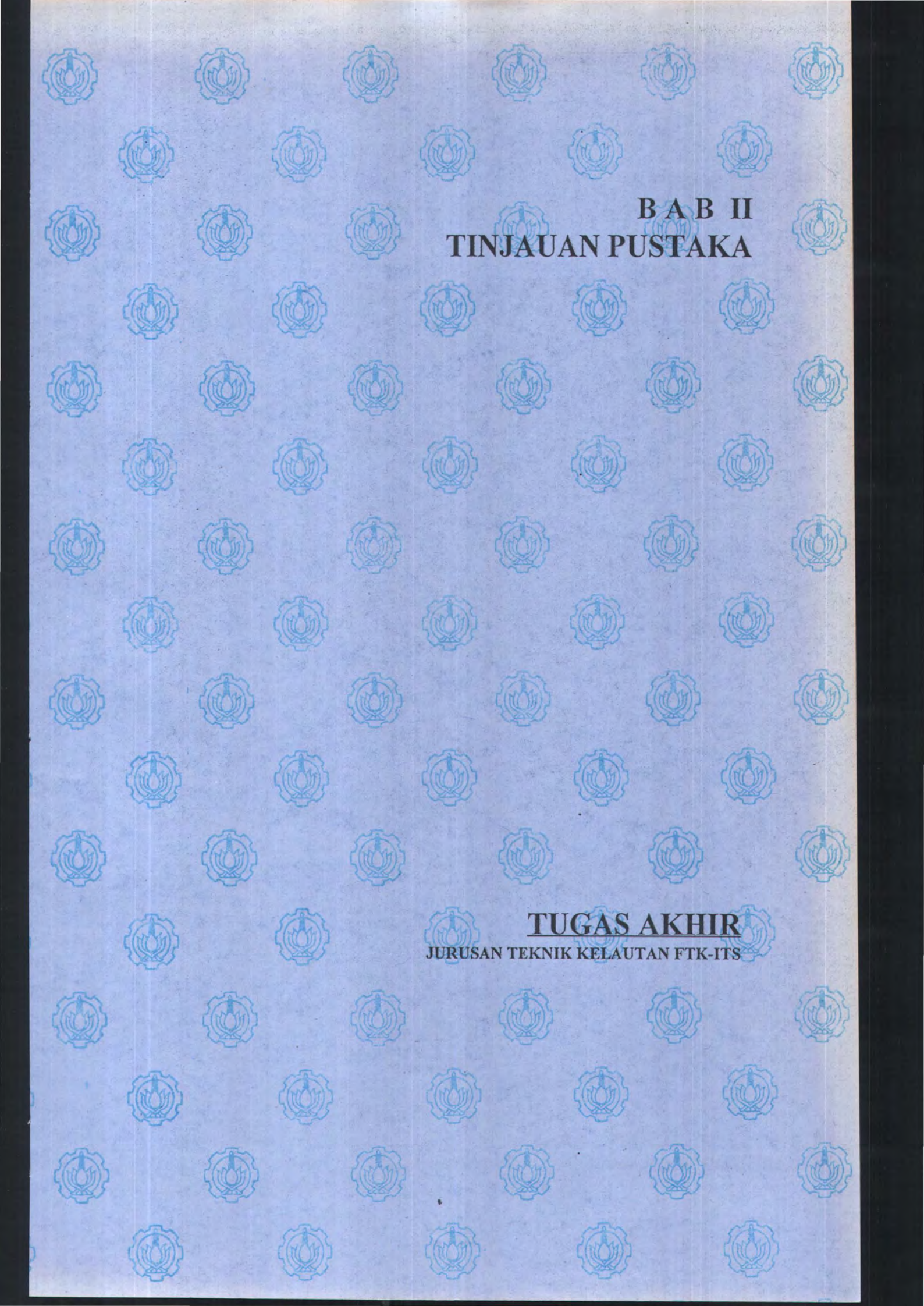

**BAB II**  
**TINJAUAN PUSTAKA**

**TUGAS AKHIR**  
JURUSAN TEKNIK KELAUTAN FTK-ITS



## BAB II

### TINJAUAN PUSTAKA

#### 2. 1. GERAKAN STRUKTUR TERAPUNG

Pada setiap struktur bangunan lepas pantai terapung yang beroperasi di permukaan air laut, akan selalu mengalami gerakan osilasi. Hal ini disebabkan adanya gaya eksitasi akibat gelombang yang bekerja pada bangunan lepas pantai terapung tersebut. Gerakan osilasi itu sendiri terdiri dari 6 (enam) macam gerakan, yaitu 3 macam gerakan lateral dan 3 macam gerakan rotasional, dalam 3 arah sumbu seperti yang ditunjukkan dalam gambar 2.1. Ke-enam macam gerakan tersebut meliputi : (a) Surging, (b) Swaying, (c) Heaving, (d) Rolling, (e) Pitching dan (f) Yawing.

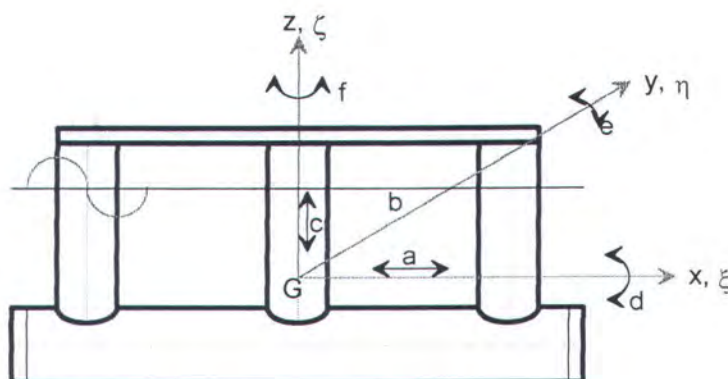

Gambar 2.1. Enam derajat kebebasan gerakan struktur terapung

Dari ke-enam macam gerakan osilasi tersebut hanya 3 gerakan saja yang bersifat murni osilasi, yaitu : Heaving, Pitching dan Rolling. Hal ini disebabkan karena ke-tiga macam gerakan tersebut bekerja dibawah gaya

atau momen pengembali ketika struktur terapung tersebut terganggu dari posisi kesetimbangannya. Sebaliknya untuk gerakan Surging, Swaying dan Yawing bukan merupakan gerakan murni osilasi, karena ke-tiga gerakan ini tidak bekerja dibawah gaya atau momen pengembali. Sehingga apabila struktur terapung tersebut terganggu dari posisi kesetimbangannya, maka struktur tersebut tidak dapat kembali pada posisi kesetimbangan semula.

Untuk menganalisa gerakan struktur terapung secara bersamaan dalam arah ke-enam gerakan tersebut sangat sulit dilakukan. Dalam tugas akhir ini akan dibahas mengenai gerakan struktur terapung yang bergerak satu derajat kebebasan dalam arah gerakan surging akibat gelombang dalam arah head sea. Struktur terapung tersebut berupa model semisubmersible dengan 6 kolom dan 2 pontoon.

Untuk memperoleh gerakan yang bersifat osilasi dalam arah gerakan surging, maka pada model dipasang suatu pegas dengan konstanta tertentu. Adapun fungsi dari pada pegas tersebut adalah sebagai gaya pengembali (*restoring forces*), dan mewakili sistem penambatan pada struktur yang sesungguhnya. Dalam gerakan osilasi teredam arah gerakan surging, dimana struktur terapung berosilasi secara harmonis, maka dalam gerakan osilasi tersebut terdapat empat faktor penting sebagai berikut <sup>(1)</sup> :

1. Gaya akibat reaksi inersia fluida ( $F_a$ )
2. Gaya redaman ( $F_b$ )
3. Gaya pengembali ( $F_c$ )



#### 4. Gaya akibat eksitasi gelombang ( $F_x$ )

Sehingga secara keseluruhan semua komponen gaya di atas harus dalam posisi kesetimbangan. Persamaan dinamis satu derajat kebebasan arah gerakan surging adalah :

$$F_a + F_b + F_c = F_x \quad (2.1)$$

Perhitungan dari komponen-komponen tersebut di atas akan dibahas dalam beberapa sub bab di bawah ini.

### 2. 2. SISTEM SATU DERAJAT KEBEBASAN

Dinamika struktur terapung yang paling sederhana dapat digambarkan sebagai sistem massa pegas yang teredam dengan satu derajat kebebasan dengan arah yang sesuai dengan arah gaya luar yang bekerja. Pada gambar 2.2 digambarkan suatu sistem dengan massa  $M$ , konstanta pegas  $K$ , dan gerakannya teredam dengan koefisien redaman  $b$ . Pada sistem tersebut bekerja gaya luar dengan amplitudo  $F_0$  dan frekwensi  $\omega$ . Persamaan gerak sistem tersebut terdiri atas gaya inersia, gaya redaman, dan gaya pengembali, yang semua gaya tersebut menahan gaya luar yang terjadi <sup>[2]</sup>. Jadi :

$$M \ddot{x} + b \dot{x} + Kx = F_0 \sin(\omega t) \quad (2.2)$$

Apabila tidak ada gaya luar yang bekerja, maka disebut dengan getaran bebas. Getaran bebas merupakan bagian dari penyelesaian umum dan disebut dengan penyelesaian transien (*transient solution*).

$$M \frac{d^2x}{dt^2} + b \frac{dx}{dt} + Kx = 0 \quad (2.3)$$

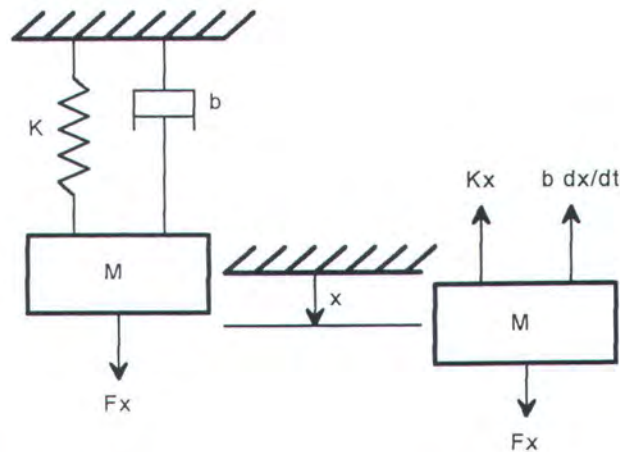

Gambar 2.2. Gaya linier teredam dari sistem massa-pegas

$$M \frac{d^2x}{dt^2} + b \frac{dx}{dt} + Kx = \zeta \quad (2.4)$$

Diasumsikan penyelesaian persamaan (2.4) mempunyai bentuk :

$$x = X e^{qt} \quad (2.5)$$

dimana X dan q adalah konstanta yang tidak diketahui. Dengan memasukkan harga x ke dalam persamaan (2.4), maka :

$$X(Mq^2 + bq + K)e^{qt} = 0 \quad (2.6)$$

yang harus dipenuhi untuk semua harga t. sehingga

$$Mq^2 + bq + K = 0 \quad (2.7)$$

Persamaan (2.7) di atas akan mempunyai dua harga q, yaitu :

$$q_{1,2} = -\frac{b}{2M} \pm \sqrt{\left(\frac{b}{2M}\right)^2 - \frac{K}{M}} \quad (2.8)$$

Apabila harga dalam tanda akar pada persamaan (2.8) sama dengan nol, maka hanya terdapat satu harga q. Kondisi demikian disebut



dengan redaman kritis (*Critical damping*) dan koefisien redaman  $b$  untuk kondisi ini disebut dengan koefisien redaman kritis  $b_c$ . Maka :

$$b_c = 2\sqrt{KM} \quad (2.9)$$

Perbandingan antara koefisien redaman  $b$  dengan koefisien redaman kritis  $b_c$  disebut dengan faktor redaman  $\zeta$ .

$$\zeta = \frac{b}{b_c} \quad (2.10)$$

Besarnya redaman pada suatu sistem dapat ditentukan dalam suku dari faktor redaman  $\zeta$ . *Sistem teredam kritis* ( $\zeta = 1$ ) mempunyai gerakan yang tidak periodik dan tidak berosilasi. Sistem dengan  $\zeta > 1$  disebut *overdamped system*, sementara jika  $\zeta < 1$  disebut *underdamped system*.

Frekwensi alami dari gerakan osilasi tidak teredam adalah :

$$\omega_n = \sqrt{\frac{K}{M}} \quad (2.11)$$

Dengan menggunakan hubungan persamaan (2.9-2.11), maka persamaan (2.8) dapat ditulis :

***untuk  $\zeta < 1.0$  (underdamped case)***

$$q_{1,2} = -\zeta\omega_n \pm i\omega_n\sqrt{1-\zeta^2} \quad (2.12)$$

Sehingga persamaan umum getaran bebas adalah :

$$x = e^{-\zeta\omega_n t}(A_1 \cos \omega_d t + A_2 \sin \omega_d t) \quad (2.13)$$

dimana besarnya nilai  $A_1$  dan  $A_2$  diperoleh dari harga awal dari permasalahan yang berhubungan dengan bagaimana gerakan struktur tersebut dimulai. Sedangkan  $\omega_d$  adalah frekwensi alami teredam, yang besarnya adalah :

$$\omega_d = \omega_n \sqrt{1 - \zeta^2} \quad (2.14)$$

**Untuk kasus  $\zeta = 1.0$  (critically- damped case)**

$$q = -\zeta\omega_n \quad (2.15)$$

Maka persamaan umum getaran bebas adalah :

$$x = (C_1 + C_2 t)e^{-\zeta\omega_n t} \quad (2.16)$$

dimana  $C_1$  dan  $C_2$  didapat dari harga awal dari permasalahan yang berhubungan dengan bagaimana gerakan struktur tersebut dimulai.

**Untuk kasus  $\zeta > 1.0$  (overdamped case)**

Persamaan umum getaran bebas untuk kasus ini adalah :

$$x = e^{-\zeta\omega_n t}(C_1 \cosh \omega^* t + C_2 \sinh \omega^* t) \quad (2.17)$$

dimana besarnya  $C_1$  dan  $C_2$  sama dengan kasus redaman kritis.

Sedangkan  $\omega^*$  adalah :

$$\omega^* = \omega_n \sqrt{\zeta^2 - 1} \quad (2.18)$$

Penyelesaian dari getaran tak bebas, persamaan (2.2), terdiri atas penyelesaian getaran bebas sebagai fungsi komplementer, dan getaran tak bebas sebagai fungsi partikular. Gaya teredam dari osilasi transien



akan hilang setelah beberapa saat sistem mulai bergerak. Jumlah cycle dari osilasi transien tergantung dari besarnya redaman pada sistem. Kemudian yang tertinggal adalah osilasi tetap (*steady state oscillation*).

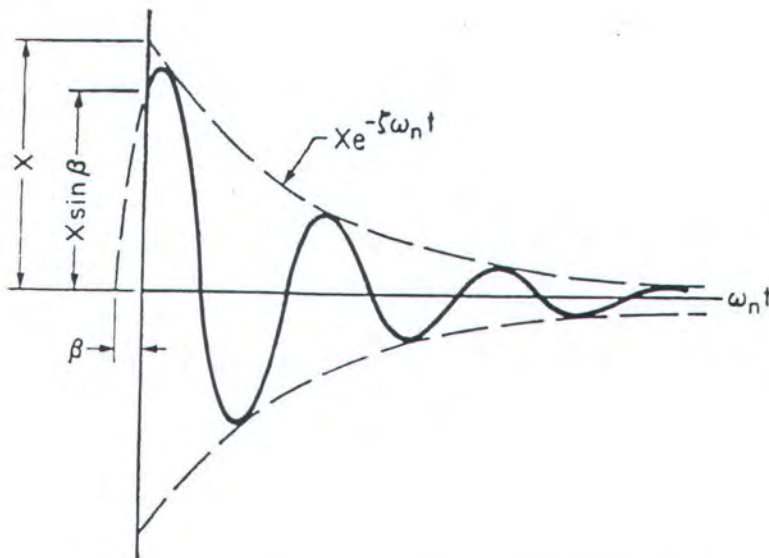

Gambar 2.3. Osilasi bebas teredam  $\zeta < 1.0$

Osilasi tetap yang bersifat harmonis diwakili oleh penyelesaian partikular dan dinyatakan sebagai berikut :

$$x = X \cos(\omega t - \beta) \quad (2.19)$$

dimana  $X$  adalah amplitudo osilasi, dan  $\beta$  adalah sudut fase antara gerakan dengan gaya luar yang bekerja. Dengan menurunkan  $x$  pada persamaan (2.19) terhadap waktu dan memasukkan ke dalam persamaan (2.2) diperoleh :

$$\begin{aligned} & -M\omega^2 X \cos(\omega t - \beta) - b\omega X \sin(\omega t - \beta) + KX \cos(\omega t - \beta) \\ & = F_0 \cos \omega t \end{aligned} \quad (2.20)$$

Persamaan di atas secara sederhana dapat diwakili dengan poligon vector gaya sebagai berikut :

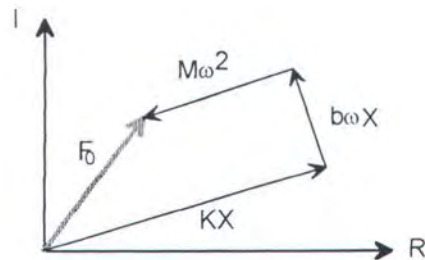

Gambar 2.4. Poligon vektor gaya

Dari gambar 2.4. di atas terlihat bahwa ;

$$F_0^2 = (KX - M\omega^2 X)^2 + (b\omega X)^2 \quad (2.21)$$

Sehingga penyelesaian untuk  $X$  dan  $\beta$  dari persamaan di atas adalah ;

$$X = \frac{F_0}{\left[ (K - M\omega^2)^2 + (b\omega)^2 \right]^{1/2}} \quad (2.22)$$

dan

$$\tan \beta = \frac{b\omega}{K - M\omega^2} \quad (2.23)$$

Defleksi statis dari sistem massa-pegas adalah :

$$X_s = \frac{F_0}{K} \quad (2.24)$$

Dengan mengingat bahwa ,  $\omega_n = \sqrt{\frac{K}{M}}$  ,  $\zeta = b/b_c$ , dan  $b_c = 2M\omega_n$ , maka penyelesaian persamaan (2.22) dapat ditulis dalam bentuk non dimensional sebagai berikut :

$$\frac{X}{X_s} = \frac{1}{\left\{ \left[ 1 - \left( \frac{\omega}{\omega_n} \right)^2 \right]^2 + \left[ 2\zeta \frac{\omega}{\omega_n} \right]^2 \right\}^{1/2}} \quad (2.25)$$



dan

$$\tan \beta = \frac{2\zeta\left(\frac{\omega}{\omega_n}\right)}{1-\left(\frac{\omega}{\omega_n}\right)^2} \quad (2.26)$$

Penyelesaian permasalahan ini digambarkan berupa grafik seperti pada gambar 2.5. di bawah ini.

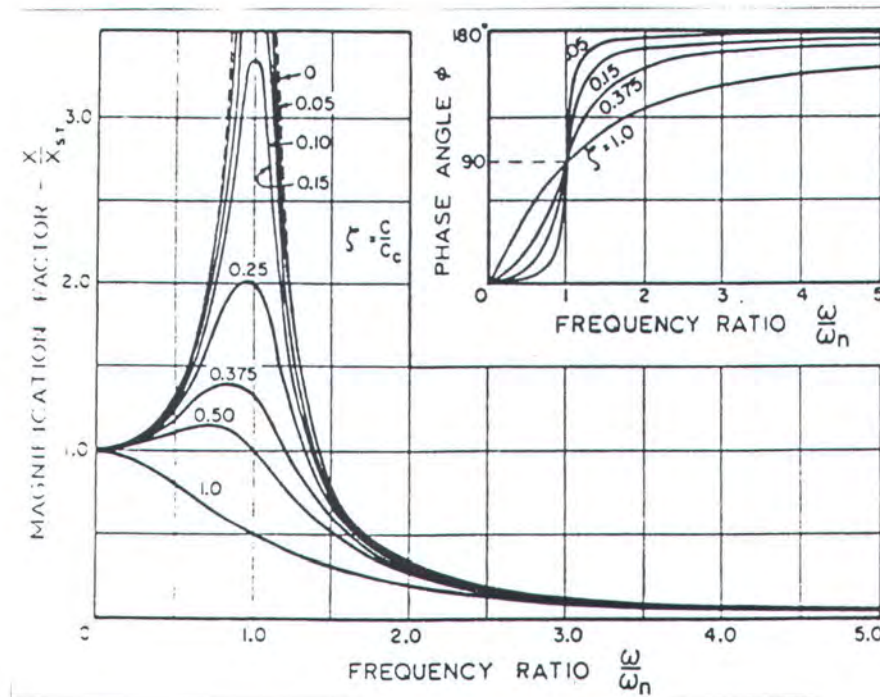

Gambar 2.5. Penyelesaian gaya linier dari sistem massa pegas

### 2. 3. TEORI STRIP

Teori strip merupakan salah satu teknik yang digunakan untuk menurunkan persamaan matematis dari gerakan benda apung. Teori ini merupakan penjabaran dua dimensi dari struktur dalam bentuk irisan-irisan yang merupakan pendekatan tiga dimensi dalam menentukan besarnya koefisien massa tambah dan koefisien redaman. Prinsip teori strip ini adalah membagi struktur (dibawah permukaan air) menjadi beberapa lapis

atau strip, seperti dalam gambar 2.6. <sup>(3)</sup>. Besarnya koefisien hidrodinamik dua dimensi dihitung pada setiap strip tersebut.

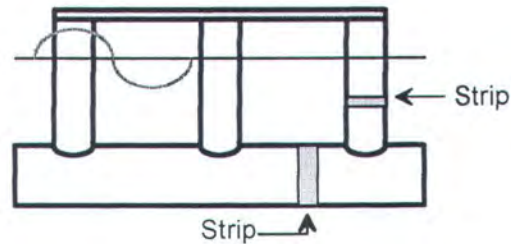

Gambar 2.6. Teori strip pada Semisubmersible

Sehingga dalam setiap strip memiliki karakteristik lokal hidrodinamik seperti koefisien massa tambah, koefisien redaman, dan koefisien pengembali yang merupakan penyusun lengkap suatu persamaan gerak dinamis struktur terapung.

Demikian juga gaya eksitasi yang bekerja pada struktur dapat ditentukan dengan menggunakan teori strip ini. Sehingga teori strip dapat menyatakan besarnya gaya eksitasi, gaya inersia, gaya redaman, dan gaya pengembali, termasuk besaran koefisien yang bekerja pada struktur tersebut.

## 2. 4. GAYA-GAYA YANG BEKERJA PADA STRIP

### 2.4.1. Gaya Inersia

Struktur terapung yang dipercepat gerakannya di dalam media fluida akan mempunyai gaya yang lebih besar dari massa struktur dikali dengan percepatannya. Hal ini disebabkan karena adanya gaya tambahan yang dibutuhkan selain untuk menggerakkan struktur juga untuk menggerakkan fluida di sekeliling struktur. Adapun gaya yang digunakan



untuk menggerakkan fluida di sekeliling struktur dinamakan **gaya massa tambah**. Sedangkan gaya total yang digunakan untuk menggerakkan struktur dan fluida di sekelilingnya disebut **gaya inersia**. Persamaan umum dari gaya inersia adalah <sup>(1)</sup> :

$$F_a = a \frac{d^2x}{dt^2}$$

$$F_a = (M + m) \frac{d^2x}{dt^2} \quad (2.27)$$

dimana  $a$  adalah massa virtual benda,  $M$  adalah massa benda,  $m$  adalah massa tambah, dan  $d^2x/dt^2$  adalah percepatan horizontal.

Gaya massa tambah disini adalah berupa distribusi tekanan, yang pada prinsipnya timbul dari fluida di sekeliling benda <sup>(6)</sup>. Karena benda tenggelam disini memberikan percepatan fluida, maka fenomena ini dapat disamakan dengan adanya massa tambah dalam jumlah tertentu yang ditambahkan pada massa benda yang sebenarnya.

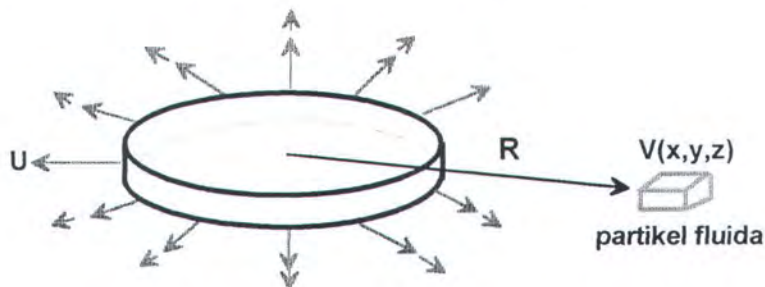

Gambar 2.7. Pengaruh gerakan benda terhadap fluida

Dalam gambar 2.7. di atas dapat dijelaskan bahwa pada saat benda dengan massa  $M$  bergerak dengan kecepatan  $U$ , maka pada benda tersebut bekerja energi kinetik sebesar  $1/2 MU^2$ . Gerakan struktur tersebut akan mempengaruhi gerakan fluida yang ada disekelilingnya, dan

mempunyai jarak tak hingga dari benda seperti terlihat dalam gambar 2.7.

Energi kinetik total fluida di sekeliling benda adalah :

$$\iiint_{\text{lim}}^{\infty} \frac{1}{2} \rho V^2(x, y, z) d\sigma \quad (2.28)$$

dimana lim adalah batas sisi benda dan  $d\sigma$  adalah volume dasar (atau luasan elementer untuk gerakan dua dimensi).

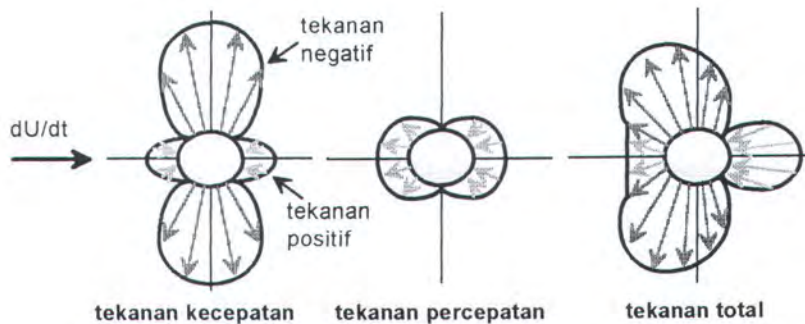

Gambar 2.8. Distribusi tekanan pada benda dipercepat

Besarnya energi kinetik total sistem (benda dan fluida) dapat ditulis :

$$W = \frac{1}{2} U^2 \left[ M + \rho \iiint_{\text{lim}}^{\infty} \left( \frac{V}{U} \right)^2 d\sigma \right] \quad (2.29)$$

dengan kuantitas massa tambah sebesar :

$$m = \rho \iiint_{\text{lim}}^{\infty} \left( \frac{V}{U} \right)^2 d\sigma \quad (2.30)$$

dimana  $m$  adalah massa tambah, yaitu massa fluida yang bergerak dengan kecepatan  $U$  yang mempunyai energi kinetik sesuai dengan massa total fluida.  $W$  adalah kerja yang diperlukan agar benda bergerak dengan kecepatan  $U$ , atau kerja yang digunakan untuk menghentikan gerakan benda tersebut. Terlihat juga bahwa kerja tersebut termasuk kerja yang digunakan untuk menggerakkan fluida di sekitarnya :  $1/2 mU^2$ . Sekali kerja



ini dihasilkan, maka benda akan terus bergerak pada fluida sempurna pada kecepatan konstan  $U$ .

Dalam kasus fluida sempurna dimana  $V(x,y,z)/U$  tidak tergantung pada  $U$ , tetapi hanya tergantung pada pola aliran. Sehingga integral koefisien  $V(x,y,z)/U$  tidak tergantung pada  $U$  dan waktu.  $m$  adalah konstan jika dihubungkan dengan benda dan massa spesifik fluida. Gaya total yang bekerja pada benda sama dengan jumlah inersia benda itu sendiri dan inersia di sekeliling benda, yaitu :

$$F = M \frac{dU}{dt} + \rho \iiint_{\text{lim}}^{\infty} \frac{dV}{dt} d\sigma \quad (2.31)$$

kemudian dapat ditulis

$$F = (M + m) \frac{dU}{dt} \quad (2.32)$$

dimana massa tambahnya adalah :

$$m = \frac{\rho(d/dt) \iiint_{\text{lim}}^{\infty} V d\sigma}{dU/dt} \quad (2.33)$$

#### 2.4.2. Gaya Redaman

Pada struktur terapung yang mendapat gaya luar maka struktur terapung tersebut akan berosilasi secara terus menerus meskipun gaya luar yang diberikan sudah tidak bekerja lagi. Tetapi pada kenyataannya struktur terapung tersebut makin lama gerakannya semakin lambat dan pada akhirnya akan berhenti. Hal ini disebabkan adanya gaya lain yang bekerja pada struktur terapung tersebut dan arahnya berlawanan dengan

gerakan struktur. Gaya yang berlawanan ini disebut dengan **gaya redaman (*damping forces*)**.

Gaya redaman ini dapat disebabkan oleh adanya viskositas fluida dan energi yang hilang dalam bentuk **creation of wave** (ombak yang diciptakan) dalam perairan <sup>(7)</sup>. Selanjutnya dalam tugas akhir ini akan dibahas mengenai penyebab yang kedua yaitu kreasi gelombang, karena pengaruh viskositas dianggap terlalu kecil.

Secara umum besarnya gaya redaman pada strip dapat digunakan pendekatan sebagai berikut <sup>(10)</sup> :

$$\frac{dF_b}{d\xi} = \sum (Cb')_{ij} \bar{q}_j \quad (2.34)$$

dimana  $\bar{q}_j$  adalah komponen kecepatan dalam arah j,  $(Cb')_{ij}$  adalah gaya pada strip per unit kecepatan sepanjang arah j akibat gerakan dalam arah i. Sedangkan C adalah faktor koreksi. Untuk gerakan surging besarnya gaya redaman per strip adalah sebagai berikut :

$$\frac{dF_b}{d\xi} = C_{xx} b'_{xx} \frac{dx}{dt} \quad (2.35)$$

dengan mengintegrasikan persamaan (2.35) terhadap  $d\xi$ , maka gaya redaman menjadi :

$$F_b = C_{xx} \frac{dx}{dt} \int_{\xi_s}^{\xi_b} b'_{xx} d\xi \quad (2.36)$$

Menurut Newman (1961) dikatakan bahwa untuk redaman tiga dimensi dari suatu struktur terbenam pada kecepatan nol, besarnya redaman



surgung merupakan fungsi frekwensi yang similar dengan gerakan heaving. Sehingga besarnya total gaya redaman menjadi :

$$F_b = C_{xx} b_{xx} \frac{dx}{dt} \quad (2.37)$$

Dengan penyamaan antara koefisien redaman surgung dan koefisien redaman heaving, dan memperkenalkan adanya faktor fraksional hasil (*fractional product factor*),  $f(\omega)$ , maka besarnya gaya redaman surgung menjadi :

$$F_b = f C_z N_z \frac{dx}{dt} \quad (2.38)$$

dimana  $f$  adalah faktor fraksional hasil yang besarnya relatif kecil ( $< 10\%$ ),  $C_z$  adalah faktor redaman tiga dimensi gerakan heaving murni, dan  $N_z$  adalah total gaya redaman gerakan heaving. Sedangkan formulasi  $N_z$  adalah sebagai berikut :

$$N_z = \frac{\rho g^2}{\omega^3} \int_{\xi_s}^{\xi_b} (\bar{A}_z)^2 d\xi \quad (2.39)$$

dimana  $\bar{A}_z$  adalah perbandingan antara amplitudo gelombang arah gerakan heaving dengan amplitudo gerakan struktur terapung, yang besarnya dapat dicari dari grafik Lewis-Form yang diperkenalkan oleh Grim (1959). Dimana grafik Lewis-Form tersebut merupakan fungsi dari  $\frac{\omega^2 B_n}{2g}$ , dan dapat dilihat pada gambar 2.9. Sehingga besarnya koefisien redaman gerakan surgung adalah :

$$b = f C_z \left| \frac{\rho g^2}{\omega^3} \int_{\xi_s}^{\xi_b} (\bar{A}_z)^2 d\xi \right| \quad (2.40)$$

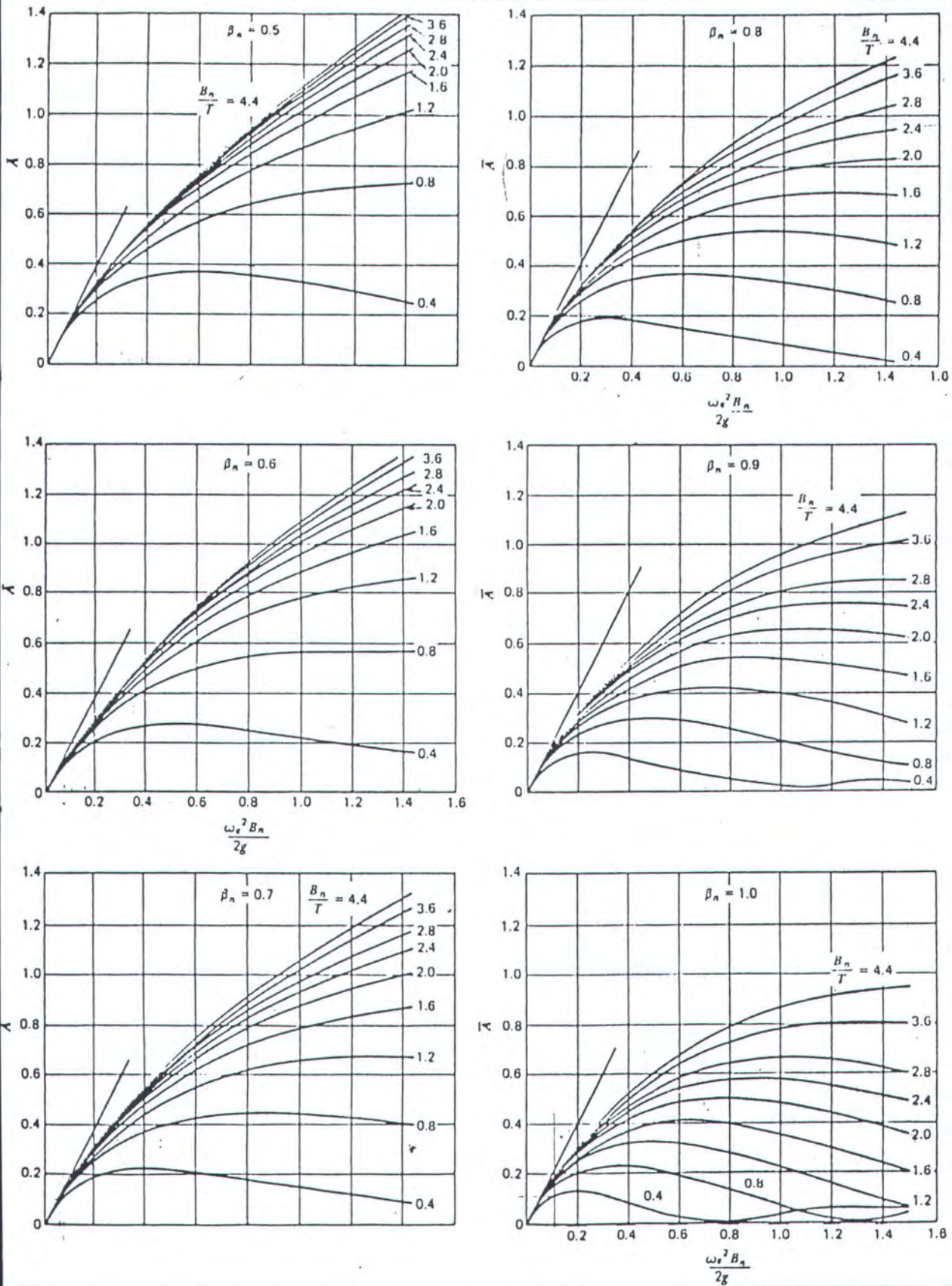

Gambar 2.9. Grafik Rasio Amplitudo Gerakan Heaving



Besarnya faktor redaman tiga dimensi gerakan heaving ( $C_z$ ) secara teori telah dipelajari oleh Havelock, dimana merupakan fungsi dari parameter frekwensi, dan digambarkan ke dalam bentuk grafik seperti dalam gambar 2.10. Adapun fungsi parameter frekwensi tersebut adalah  $\frac{\omega^2 L}{g}$

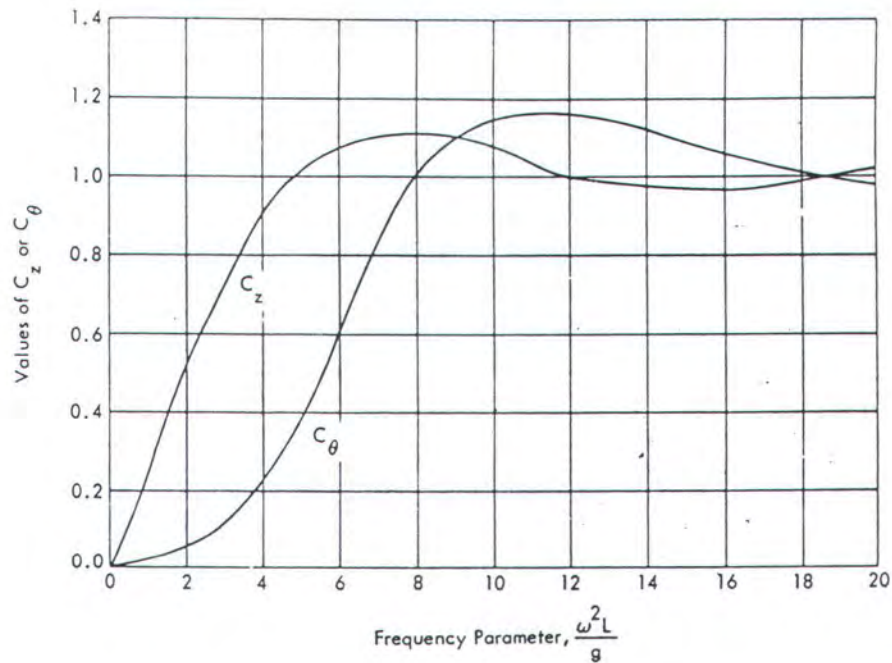

Gambar 2.10a. Faktor redaman tiga dimensi gerakan heaving

Sehingga secara umum besarnya koefisien redaman suatu struktur terapung tergantung pada beberapa faktor sebagai berikut :

- a. tipe gerakan osilasi
- b. frekwensi encountering
- c. bentuk benda

### 2.4.3. Gaya Pengembali

Gaya pengembali adalah gaya yang membawa struktur terapung kembali ke dalam posisi kesetimbangan semula. Gaya pengembali untuk

struktur terapung yang tertambat (*mooring floating structures*) mempunyai pengaruh yang terbesar terhadap simpangan (*displacement*), terutama untuk struktur yang bergerak horisontal seperti gerakan surging. Dalam tugas akhir ini untuk mendapatkan besarnya gaya pengembali atau gaya tambatan (*mooring forces*) digunakan pegas dengan nilai konstanta tertentu, yang juga berfungsi untuk menimbulkan gerakan yang bersifat osilasi pada struktur terapung tersebut. Secara umum besarnya gaya pengembali adalah :

$$F_c = K \cdot x \quad (2.41)$$

dimana K adalah konstanta pegas, dan x adalah simpangan.

Sehingga besarnya konstanta pegas merupakan hasil bagi gaya pengembali dengan simpangan. Gaya pengembali tersebut merupakan gaya reaksi dari gaya akibat aksi gelombang (*gaya eksitasi*)<sup>(4)</sup>. Jadi :

$$K = \frac{-F_c}{x} = \frac{F_x}{x} \quad (2.42)$$

Dalam gambar 2.11. di bawah dapat dilihat hubungan antara gaya reaksi (gaya pengembali) dengan gaya luar (gaya eksitasi) pada sistem pegas sederhana.

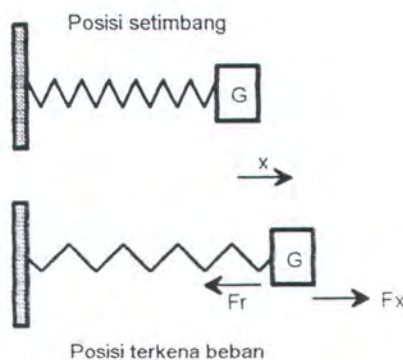

Gambar 2.10b. Skema hubungan gaya reaksi ( $F_r$ ) dan gaya luar ( $F_e$ )



## 2. 5. GAYA EKSITASI

Gerakan dari suatu struktur terapung pada suatu perairan tenang berbeda dengan jika struktur terapung tersebut bergerak pada perairan yang bergelombang. Hal ini disebabkan karena gelombang merupakan suatu gaya dan besarnya gaya gelombang tersebut berubah-ubah sebagai fungsi waktu. Gaya eksitasi ini perlu diketahui sebelum dilakukannya analisa terhadap gaya-gaya hidrodinamis seperti massa tambah dan gaya redaman.

Dalam mengevaluasi gerakan struktur terapung akibat eksitasi gaya gelombang suatu silinder, dapat ditunjukkan bahwa gaya tersebut timbul karena 3 (tiga) komponen<sup>(9)</sup>, yaitu :

1. Variasi tekanan dinamik (dynamic pressure) oleh gelombang. tekanan dinamik tersebut adalah :  $p = \rho g a_0 e^{ky} \cos k(x - ct)$  . Gaya akibat tekanan dinamik ini biasa disebut dengan gaya Froude-Krylov.
2. Perubahan tekanan pada permukaan struktur yang disebabkan oleh interferensi dengan percepatan partikel gelombang. Besarnya gaya tersebut merupakan perkalian antara massa tambah dengan percepatan.
3. Perubahan tekanan pada permukaan struktur yang disebabkan oleh pengaruh viskositas yang timbul dari interferensi dengan kecepatan partikel gelombang.

Secara umum besarnya gaya eksitasi gelombang per unit panjang pada suatu silinder sirkular diformulasikan dengan persamaan Morison sebagai berikut :

$$\begin{aligned} \text{Gaya/sat.panjang} = & (\rho[1 + m] \times \text{perc. partikel} \times \text{luas} \\ & \text{penampang benda)} \\ & + (1/2C_D \times \text{luas pro. melintang} \times \\ & \text{kec.partikel}|\text{kec.partikel}| \quad (2.43) \end{aligned}$$

Formula di atas menunjukkan bahwa dalam menentukan besarnya gaya eksitasi akibat gelombang terutama sekali dipengaruhi oleh dimensi struktur. Persamaan Morison berlaku jika diameter struktur tidak lebih dari seperlima dari panjang gelombang. Karena asumsi yang digunakan bahwa struktur terapung tersebut adalah ramping (*slender bodies*), sehingga struktur tersebut tidak mempengaruhi atau merubah karakteristik gelombang pada saat gelombang melaluinya.

Untuk menentukan gaya eksitasi akibat gelombang pada model semisubmersible di atas dapat diuraikan ke dalam masing-masing komponen silinder. Dengan asumsi bahwa interferensi hidrodinamik antar komponen silinder tersebut diabaikan. Untuk kasus head sea, perhitungan gaya eksitasi hanya dilakukan pada satu sisi saja. Hal ini disebabkan besarnya beban gelombang yang diterima struktur antara sisi satu dengan yang lain adalah sama.

Gaya eksitasi pada kolom dipengaruhi oleh gaya akibat percepatan (gaya inersia) dan akibat kecepatan. Besarnya tekanan dan gaya percepatan pada elemen kecil  $dz$  dari kolom adalah :



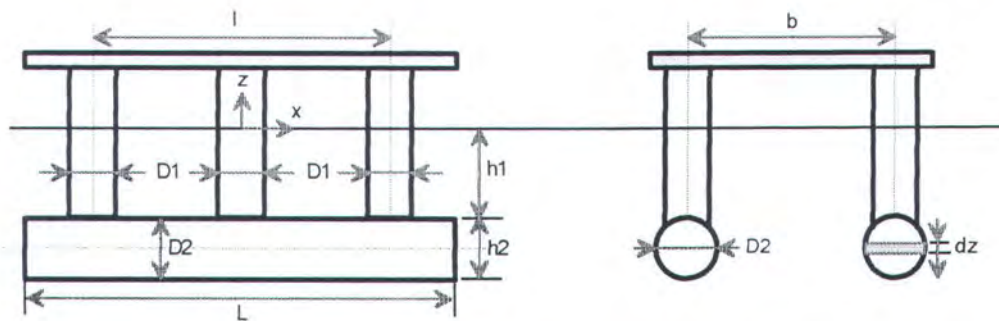

Gambar 2.11. Dimensi model semisubmersible

$$\frac{dF_x(v)_a}{dz} = \rho(1+m)\pi R_1^2 k g a_0 e^{kz} \sin k(x-ct) \quad (2.44)$$

dimana  $m$  adalah koefisien massa tambah yang besarnya mendekati 1.0, dan merupakan fungsi dari Reynolds Number, Keulegan Carpenter Number, dan kekasaran.

Dengan mengintegalkan persamaan (2.44) di atas dari permukaan gelombang sampai dasar kolom, didapat besarnya gaya eksitasi pada kolom akibat kontribusi inersia sebagai berikut <sup>(9)</sup> :

$$F_x(v)_a = \rho(1+m)\pi R_1^2 g a_0 \left[ e^{ka_0} \cos k(x-ct) - e^{-kh_1} \right] x \sin k(x-ct) \quad (2.45)$$

Pengaruh yang kedua yaitu akibat perubahan tekanan pada permukaan struktur akibat efek viskositas. Besarnya gaya kecepatan ini adalah :

$$\frac{dF_x(v)_b}{dz} = \frac{1}{2} \rho C_D (2R_1) k^2 c^2 a_0^2 e^{2kz} |\cos k(x-ct)| \cos k(x-ct) \quad (2.46)$$

Besarnya gaya tersebut akan maksimum apabila gelombang berada pada posisi puncak pada saat melalui kolom. Dengan mengintegalkan

persamaan (2.46) sepanjang kedalaman kolom yang tercelup air, maka akan didapat total gaya akibat kecepatan sebagai berikut :

$$F_x(v)_b = \frac{1}{2} \rho g C_D R_1 a_0^2 \left( e^{2ka_0 \cos k(x-ct)} - e^{-2kh_1} \right) |\cos k(x-ct)| \cos k(x-ct) \quad (2.47)$$

Sedangkan besarnya gaya eksitasi untuk gerakan surging pada pontoon (silinder horisontal) pada umumnya disebabkan oleh perbedaan tekanan pada ujung belakang dan depan dari pontoon. Besarnya gaya tekanan pada elemen luas dari silinder horisontal tersebut adalah :

$$dF_x(h) = \rho g a_0 e^{kz} \cos k(x-ct) dA \quad (2.48)$$

karena besarnya  $dA = R^2 \cos \theta dz$ , maka besarnya gaya tekanan dari ujung depan sampai ujung belakang pontoon adalah :

$$F_x(h) = \rho g a_0 \int_{h_1+h_2}^{h_1} e^{kz} R^2 \cos \theta dz \left[ \cos k\left(-\frac{L}{2} - ct\right) - \cos k\left(\frac{L}{2} - ct\right) \right] \quad (2.49)$$

Dalam beberapa ilustrasi di atas menunjukkan pendekatan yang digunakan untuk menentukan besarnya gaya eksitasi gelombang. Untuk model semisubmersible seperti yang digunakan dalam tugas akhir ini, maka perhitungan gaya eksitasi merupakan penjumlahan tiap gaya yang bekerja pada setiap silinder.



## 2. 6. BEBAN DAN TEORI GELOMBANG

### 2.6.1. Beban Gelombang

Dalam operasinya satu struktur bangunan lepas pantai akan banyak mendapat perlakuan beban-beban lingkungan, seperti gelombang, beban angin dan beban arus. Namun dari ketiga beban tersebut, beban gelombang merupakan beban lingkungan yang berpengaruh paling besar.

Ada 3 (tiga) metode yang dapat digunakan untuk menentukan besarnya gaya gelombang pada suatu struktur bangunan laut, yaitu <sup>(2)</sup> :

- persamaan Morison
- teori Froude-Krylov, dan
- teori difraksi.

Beberapa parameter pokok yang menentukan pemilihan metode pendekatan atau prosedur perhitungan beban gelombang adalah geometri struktur, panjang dan tinggi gelombang. Ketiga parameter tersebut pada umumnya dinatakan dalam bentuk perbandingan yaitu :

- ♦ perbandingan antara geometri struktur dengan panjang gelombang
- ♦ perbandingan antara tinggi gelombang dengan geometri struktur.

Penjelasan dari kedua perbandingan tersebut adalah sebagai berikut :

#### 1. Perbandingan antara diameter struktur terhadap panjang gelombang

$(D/\lambda)$

Perbandingan ini menyatakan ukuran struktur relatif terhadap gelombang, yang berarti sejauh mana pengaruh struktur tersebut dengan karakteristik gelombang, yaitu sebagai berikut :

- ♦ Untuk  $(D/\lambda) \leq 0.2$ , struktur dianggap kecil jika dibanding dengan panjang gelombang, sehingga struktur tidak mempengaruhi atau merubah karakteristik gelombang yang melaluinya, dalam kasus ini perhitungan gelombang menggunakan Teori Morison.
- ♦ Untuk  $(D/\lambda) > 0.2$ , geometri struktur cukup besar jika dibandingkan dengan panjang gelombang, sehingga berpengaruh terhadap karakteristik gelombang yang melaluinya. Dalam hal ini refleksi dan radiasi energi gelombang akibat interaksi struktur dengan gelombang harus diperhitungkan. Untuk kasus demikian, teori Morison tidak dapat dipakai, tetapi menggunakan pendekatan dengan teori difraksi.

## 2. Perbandingan antara tinggi gelombang dengan geometri struktur ( $H/D$ )

Perbandingan ini menyatakan pengaruh tinggi gelombang yang bekerja pada suatu struktur dengan geometri tertentu terhadap pola aliran yang akan dihasilkan. Perbandingan tersebut yaitu :

- ♦ Untuk  $H/D$  kecil, ( $H/D < 1.5$ ), maka diameter orbit partikel yang terjadi juga kecil, sehingga aliran searah yang timbul juga kecil, sehingga tidak mampu untuk menimbulkan pemisahan maupun pusaran aliran. Dalam hal ini gaya drag sangatlah kecil, sehingga gaya yang dominan adalah gaya inersia.
- ♦ Untuk  $H/D$  besar ( $H/D > 8$ ), aliran searah yang terjadi juga besar, sehingga aliran akan mengalami pemisahan dan terjadi pusaran, setelah aliran tersebut melewati struktur. Sehingga gaya drag yang timbul dalam hal ini adalah besar.



### 2.6.2. Teori Gelombang

Untuk menurunkan persamaan persamaan beban-beban yang diterima oleh struktur digunakan teori gelombang linier. Di bawah ini akan disajikan teori dasar gelombang linier.

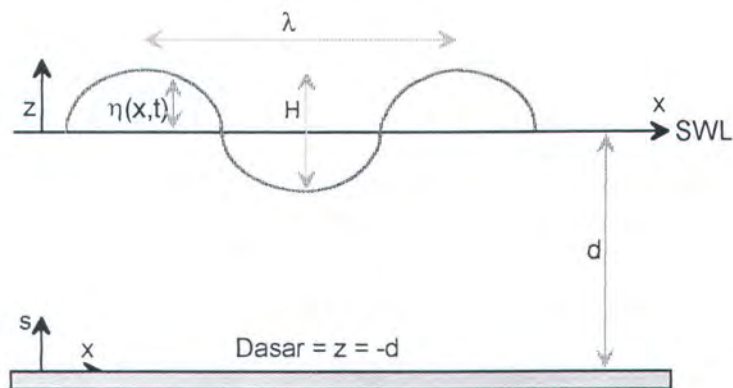

Gambar 2.12. Profil Gelombang

#### *Teori Gelombang Linier/Airy (small amplitude wave theory)*

Teori gelombang ini adalah relatif sederhana, dikembangkan pertama kali oleh G. B. Airy pada tahun 1842. Asumsi yang digunakan dalam teori gelombang ini adalah bahwa tinggi gelombang  $H$  dianggap kecil jika dibandingkan dengan panjang gelombang dan kedalaman air, sedang bentuk gelombang adalah sinusoidal. Teori gelombang ini dapat digunakan baik untuk perairan dangkal, sedang, dan perairan dalam.

Beberapa persamaan yang umum digunakan dalam teori gelombang linier antara lain <sup>(2)</sup> :

$$(\lambda) = H/2 \cos(kx - \omega t) \quad (2.50)$$

$$k = \frac{2\pi}{\lambda} \quad (2.51)$$

$$\omega = 2\pi/T \quad (2.52)$$

$$\omega^2 = gk \tanh kd \quad (2.53)$$

Sedangkan kecepatan horisontal  $u$  dan kecepatan vertikal  $v$  dari partikel air pada posisi  $(x,y)$  dan waktu  $t$ , diekspresikan sebagai berikut :

$$u = \frac{\omega H \cosh ks}{2 \sinh kd} \cos(kx - \omega t) \quad (2.54)$$

$$v = \frac{\omega H \sinh ks}{2 \sinh kd} \sin(kx - \omega t) \quad (2.55)$$

Percepatan horisontal  $a_x$  dan percepatan vertikal  $a_y$  dapat diperoleh dengan menurunkan  $u$  dan  $v$  terhadap waktu. Sehingga persamaan  $a_x$  dan  $a_y$  adalah sebagai berikut :

$$a_x = \frac{\omega^2 H \cosh ks}{2 \sinh kd} \sin(kx - \omega t) \quad (2.56)$$

$$a_y = -\frac{\omega^2 H \sinh ks}{2 \sinh kd} \cos(kx - \omega t) \quad (2.57)$$

## 2. 7. REGION OF VALIDITY

Untuk mendapatkan teori gelombang pendekatan yang sesuai dalam menurunkan persamaan beban gelombang yang diterima oleh struktur maka digunakan *region of validity* dalam bentuk grafik. Region of validity ini adalah hasil kerja dari Dean (1968) dan Le Mehaute (1970). Grafik ini merupakan fungsi dari  $d/T^2$  dan  $H/T^2$ , dimana  $d$  = kedalaman perairan,  $T$  = periode gelombang, dan  $H$  = tinggi gelombang. Dengan menghitung terlebih dahulu  $d/T^2$  (ft/sec<sup>2</sup>) dan  $H/T^2$  (ft/sec<sup>2</sup>) pada masing-masing perairan yang ditinjau dapat ditentukan teori gelombang



yang sesuai. Grafik Region Of Validity dari Chakrabarti, S. K. (1987) ditunjukkan dalam gambar (2.13).

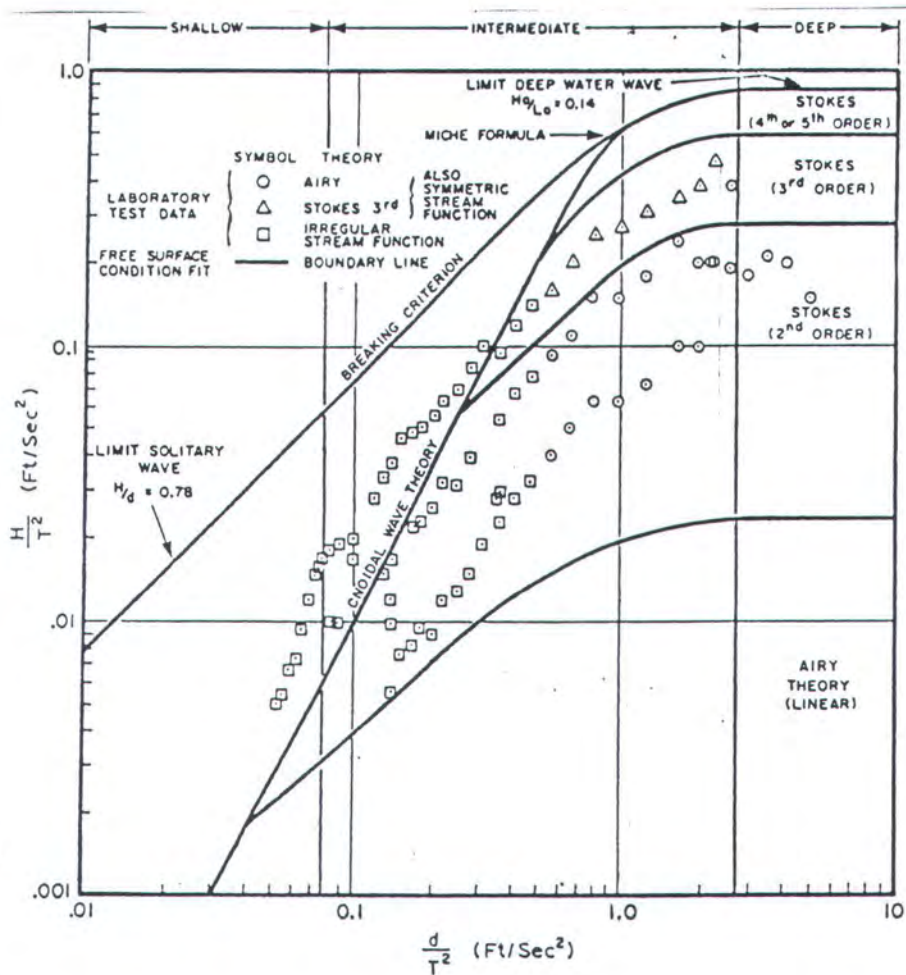

Gambar 2.13. Region Of Validity Chakrabarti, S. K.

### 2.8. HUKUM KESAMAAN

Untuk mengidealisasikan suatu model agar mendekati kondisi yang sesungguhnya, maka perlu adanya syarat-syarat kesamaan. Adapun syarat-syarat kesamaan tersebut adalah :

- Kesamaan geometri (*Geometri similarity*)
- Kesamaan kinematik (*Kinematic similarity*)
- Kesamaan dinamis (*Dynamic similarity*)

Penjelasan dari hukum-hukum kesamaan tersebut adalah sebagai berikut :

a. Kesamaan Geometri (*Geometri Similarity*)

Kesamaan geometri adalah kesamaan perbandingan antara ukuran model dengan prototype. Adapun besar dari kesamaan ini adalah selalu konstan. Secara matematis dapat dituliskan sebagai berikut

$$\lambda_1 = \frac{L_p}{L_m} = \frac{B_p}{B_m} = \frac{T_p}{T_m} = \text{konstan} \quad (2.58)$$

dimana

$L_p$  = Panjang sesungguhnya                       $L_m$  = Panjang model

$B_p$  = Lebar sesungguhnya                       $B_m$  = Lebar model

$T_p$  = Tinggi Sesungguhnya                       $T_m$  = Tinggi model

$\lambda_1$  = Konstanta (prototype/model)

b. Kesamaan Kinematik (*Kinematic Similarity*)

Kesamaan kinematik adalah kesamaan mengenai perbandingan antara kecepatan prototype dengan kecepatan model terhadap suatu titik.

Secara matematis perbandingan tersebut dapat ditulis sebagai berikut :

$$\frac{V_m}{\sqrt{gL_m}} = \frac{V_p}{\sqrt{gL_p}} \quad \text{Fn}(m) = \text{Fn}(p) \quad (2.59)$$

$$\frac{V_m L_m}{\nu_m} = \frac{V_p L_p}{\nu_p} \quad \text{Re}(m) = \text{Re}(p) \quad (2.60)$$

dimana  $V_m$  = kecepatan model



- $V_p$  = kecepatan prototype  
 $\nu_m$  = viskositas kinematis model  
 $\nu_p$  = viskositas kinematis prototype  
 $Re$  = bilangan Reynold

### c. Kesamaan Dinamis (*Dynamic Similarity*)

Kesamaan dinamis adalah apabila dua sistem dinamis mempunyai rasio yang sama diantara keduanya. Gaya-gaya yang bekerja pada elemen fluida meliputi gaya gravitasi ( $F_g$ ), gaya tekan ( $F_p$ ), gaya viskositas ( $F_v$ ), gaya elastisitas ( $F_e$ ), dan gaya inersia ( $F_a$ ). Secara sistematis hubungannya dapat ditulis sebagai berikut :

$$\frac{F_g(p)}{F_g(m)} = \frac{F_p(p)}{F_p(m)} = \frac{F_v(p)}{F_v(m)} = \frac{F_a(p)}{F_a(m)} \quad (2.61)$$

$$\left(\frac{F_a}{F_g}\right)_p = \left(\frac{F_a}{F_g}\right)_m \left(\frac{F_a}{F_p}\right)_p = \left(\frac{F_a}{F_p}\right)_m \left(\frac{F_a}{F_v}\right)_p = \left(\frac{F_a}{F_v}\right)_m \quad (2.62)$$

Jadi untuk mengidealisasikan model agar dapat memenuhi keadaan yang sesungguhnya, maka semua hukum kesamaan di atas harus dipenuhi.

## 2. 9. PENELITIAN-PENELITIAN TERHADAP KOEFISIEN REDAMAN

J. E. W. Wichers (1979) <sup>(11)</sup> melakukan penelitian mengenai penentuan koefisien redaman ( $b$ ) pada suatu kapal tanker 250 KDWT pada arah gerakan surging. Hasil yang didapat menunjukkan besaran hasil koefisien redaman tersebut berkisar antara 0 - 750 (ton-sec/m). Percobaan tersebut menggunakan rentang frekwensi ( $\omega$ ) antara 0 - 15 rad/sec, kondisi sarat 6.40 m, 10.68 m, dan 19.98 m, serta pada kedalaman air 60

m. Hasil percobaan seperti ditunjukkan dalam gambar (2.14) menunjukkan bahwa koefisien redaman cenderung meningkat seiring meningkatnya frekwensi gelombang.

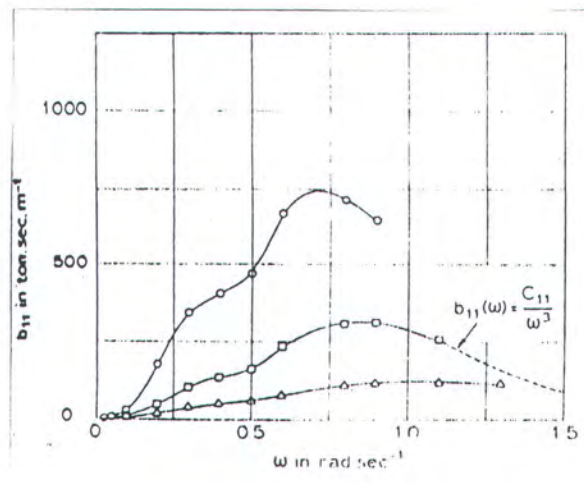

Gambar 2.14. Koefisien Redaman gerakan surging pada tanker 250 KDWT, J. E. W. Wichers.

Mikkelsen, J. dan Calisal, S. M. (1993) <sup>(8)</sup> melakukan penelitian mengenai koefisien redaman surging pada suatu silinder gabungan (vertikal), seperti dalam gambar 2.15. Percobaan tersebut dilakukan pada kondisi sarat 87 cm dan 94 cm, dengan variasi amplitudo gelombang yaitu 1.0 cm dan 2.5 cm.

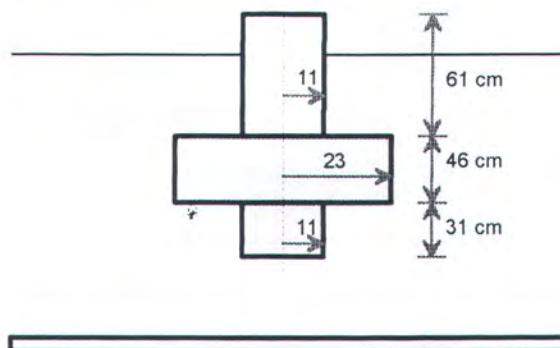

Gambar 2.15. Konfigurasi Silinder Gabungan  
Mikkelsen, J. dan Calisal, S. M. (1993)



Koefisien redaman yang dihasilkan untuk sarat 87 cm berkisar antara 0.0 - 0.4, dan untuk sarat 94 cm berkisar antara 0.0 - 0.25. Grafik koefisien redaman tersebut dapat dilihat pada gambar 2.16 dan 2.17.

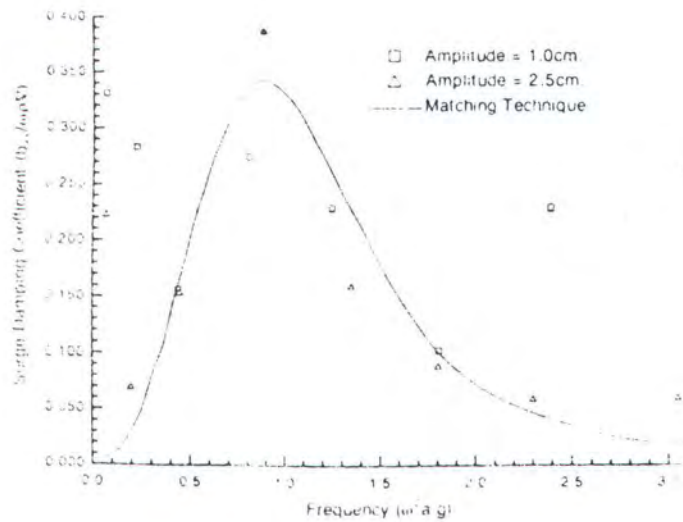

Gambar 2.16. Grafik Koefisien redaman Gerakan Surging Silinder Gabungan Sarat 87 cm, Mikelsen, J. & Calisal, S. M. (1993)

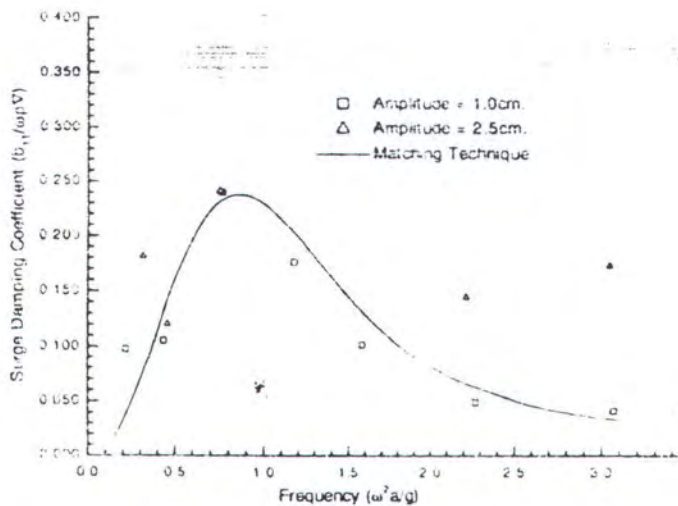

Gambar 2.17. Grafik Koefisien redaman Gerakan Surging Silinder Gabungan Sarat 94 cm, Mikelsen, J. & Calisal, S. M. (1993)

Penelitian lain mengenai koefisien redaman gerakan surging dilakukan oleh J. P. Hooft (1982) <sup>(4)</sup> pada suatu barge dengan dimensi seperti pada gambar 2.18 di bawah ini. Penelitian ini menggunakan rentang frekwensi antara 0.0 - 1.5 rad/dt.

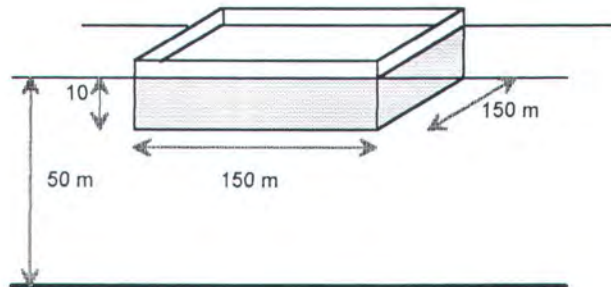

Gambar 2.18. Barge segiempat J. P. Hooft (1982)

Koefisien redaman yang dihasilkan berkisar antara 0 -  $10^7$  N-dt/m. Grafik hasil penelitian tersebut dapat dilihat dalam gambar 2.19.

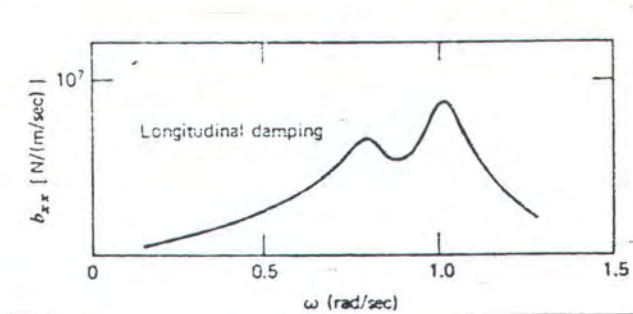

Gambar 2.19. Grafik Koefisien Redaman Barge Segiempat J. P. Hooft (1982)

Penelitian lain yang dilakukan oleh J. P. Hooft (1982) <sup>(4)</sup> mengenai koefisien redaman dalam arah gerakan surging yaitu pada suatu struktur circular platform seperti dalam gambar 2.20. Dalam penelitian ini digunakan rentang frekwensi antara 0 - 1 rad/dt. Besarnya koefisien



redaman yang terjadi berkisar antara  $0 - 10^8$  N-dt/m. Grafik hasil koefisien redaman tersebut dapat dilihat pada gambar 2.21.

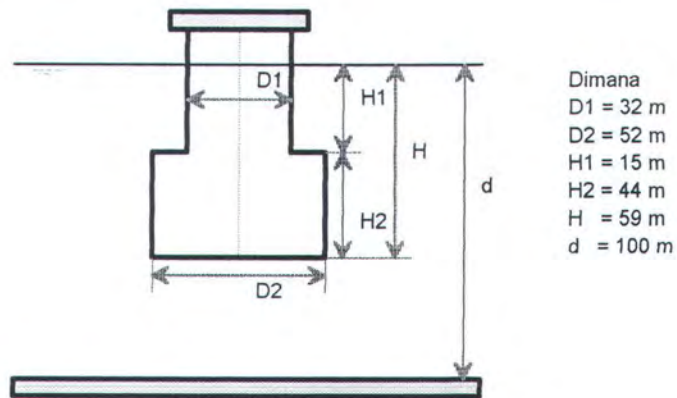

Gambar 2.20. Circular Platform J. P. Hooft (1982)

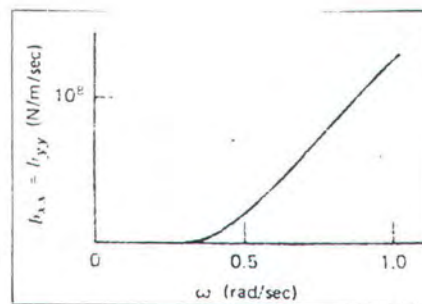

Gambar 2.21. Grafik Koefisien Redaman Surging  
 Circular Platform J. P. Hooft (1982)





**B A B III**  
**METODOLOGI PENELITIAN**

**TUGAS AKHIR**  
**JURUSAN TEKNIK KELAUTAN FTK-ITS**



## 3. 2. PERSIAPAN PERCOBAAN

### 3.2.1. Persiapan Model Semisubmersible

Dalam eksperimen ini digunakan model semisubmersible yang sudah ada di Laboratorium Hidrodinamika FTK - ITS. Model semisubmersible tersebut terdiri atas 2 (dua) buah ponton dan 6 (enam) buah kolom yang terbuat dari bahan flexiglass, sedang bagian deck terbuat dari bahan triplex. Dimensi model semisubmersible tersebut dapat dilihat pada gambar 3.1.

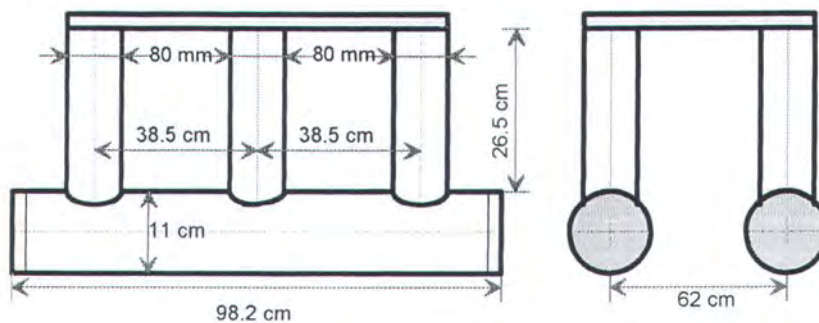

Gambar 3.1. Dimensi Model Semisubmersible

Untuk mendapatkan gerakan surgung murni yang dibutuhkan pada eksperimen ini, digunakan sepasang rel sebagai pengarah yang terbuat dari bahan alumunium dan roda yang terbuat dari bearing dan flexigalass, diatur sedemikian rupa sehingga gerakan yang diinginkan tercapai. Sedangkan untuk mendapatkan gerakan osilasi, maka pada model dipasang pegas dengan nilai yang telah ditentukan (lihat lampiran). Untuk menghubungkan model dengan rel digunakan alat pemegang yang terbuat dari bahan plat dan besi. Dalam gambar 3.2. dapat dilihat setting dari alat

pemegang dan pengarah. Sedang setting dari pada model dengan alat pengukur dapat dilihat pada gambar 3.3.

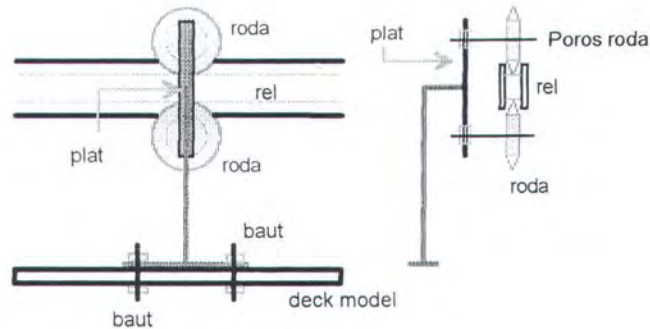

Gambar 3.2. Setting alat pemegang dan pengarah

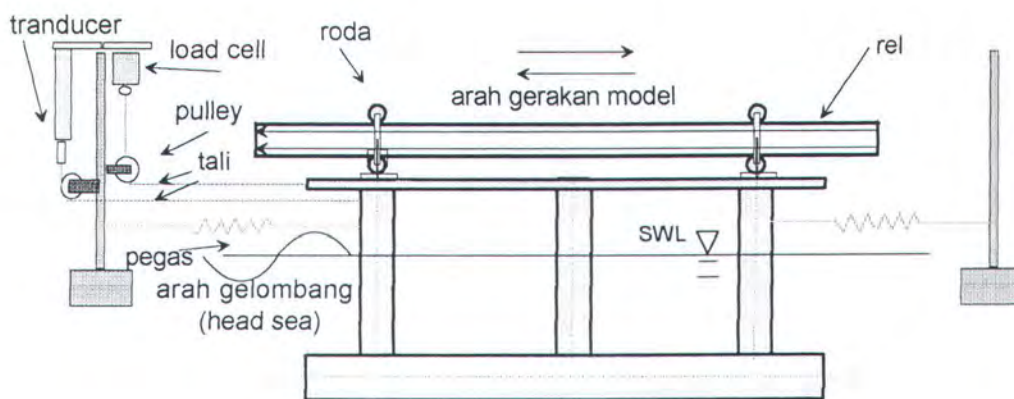

Gambar 3.3. Setting model dan peralatan pengukur

Pada eksperimen ini digunakan variasi 3 (tiga) sarat , yaitu sarat 6.5 cm, 11 cm, dan 22.4 cm. Sarat 6.5 cm merupakan sarat dimana model berada pada kondisi terapung bebas (free floating) tanpa diberi pemberat ataupun busa pengapung. Sedang sarat 11cm merupakan sarat dimana garis air berada pada satu diameter pontoon. Untuk sarat 22.4 cm merupakan sarat operasional dari model semisubmersible yang didapatkan dari hukum kesamaan geometris dengan menggunakan perbandingan



tertentu antara model dengan semisubmersible sebenarnya. Data - data ukuran dari semisubmersible dan model tersebut diberikan pada tabel berikut :

BAGIAN	SEMISUB MERSIBLE (cm)	MODEL (cm)	RASIO
Length Over All (LOA)	9020	98.2	0,01089
Breadth Over All(BOA)	5740	73,0	0,01272
Pontoon Diameter	940	11,0	0,01170
Coloumn Diameter	795	8,0	0,01006
Main Deck Height	3450	37,5	0,01087
Draft (T)	2240	?	0.01

Tabel 3.1. Perbandingan dimensisemisubmersible dan model

Dari perhitungan tersebut perbandingan rata - rata adalah 0.01, sehingga sarat dari model didapatkan :

$$T_{\text{model}} = 0.01 \times 2240 = 22.4 \text{ cm}$$

Untuk mendapatkan sarat pertama (6.5 cm) model diletakkan pada kondisi free floating tanpa ada pemberat ataupun busa pengapung. Kemudian ketinggian dari pada rel disesuaikan sedemikian sehingga tidak terjadi gesekan antara roda dengan rel. Untuk sarat kedua (11cm) digunakan pemberat dari pasir yang diletakkan pada kedua sisi pontoon, dan di atas deck sedemikian rupa sehingga kondisi model tetap stabil dan memenuhi sarat yang diinginkan. Kemudian dilakukan penyesuaian ketinggian rel. Dan untuk sarat ketiga (22.4 cm) digunakan busa pengapung yang diletakkan di dalam kedua pontoon dengan ukuran tertentu, dan diisi dengan air sampai benar-benar terisi penuh (tidak ada

celah). Kemudian ketinggian rel menyesuaikan sehingga tidak ada gesekan yang timbul antara roda dan rel.

Model dan semua peralatan eksperimen diletakkan dalam satu kereta khusus, seperti yang ditunjukkan dalam gambar 3.4. di bawah ini.

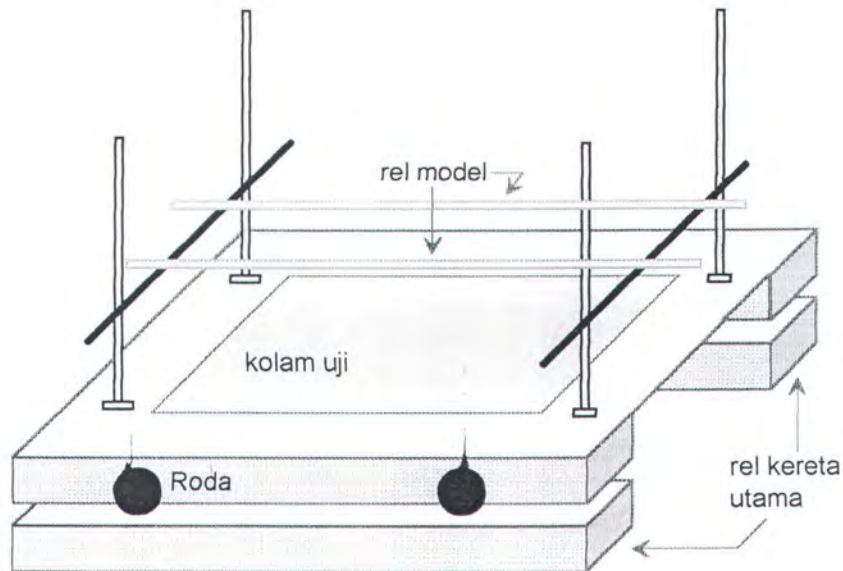

Gambar 3.4. Kereta dan Perlengkapannya

### 3.2.2. Fasilitas Dan Perangkat Eksperimen

#### 1. Kolam Uji

Kolam uji yang ada di Laboratorium Hidrodinamika FTK - ITS terbuat dari beton dengan ukuran sebagai berikut :

- Panjang = 55.0 meter
- Lebar = 3.0 meter
- Tinggi = 2.0 meter
- Kedalaman air = 1.902 meter



## **2. H. P. Personal Computer**

Perangkat komputer yang digunakan adalah Hewlett Packard Personal Computer, untuk mengendalikan semua kegiatan percobaan melalui suatu paket program.

## **3. Amplifier**

Amplifier ini berfungsi untuk membangkitkan sinyal-sinyal tegangan input yang dibutuhkan oleh rangkaian jembatan Wheatstone dan berguna untuk menangkap sinyal kembali serta memperbesar sinyal sehingga dapat dibaca. Amplifier yang digunakan terdiri dari tiga amplifier yaitu amplifier load cell, amplifier sea simulation (wave probe) dan amplifier displasemen transducer. Untuk amplifier pengukur harga load cell, amplifier yang digunakan adalah HBM Amplifier tipe KWS 3072. Semua amplifier dihubungkan ke ADC/DAC untuk diubah dari output analog menjadi digital.

## **4. ADC/DAC Interface**

Laboratorium Hidrodinamika FTK ITS dilengkapi dengan interface ADC/DAC (Analog to Digital Converter & Digital to Analog Converter) buatan Byte. Alat ini berfungsi untuk mengubah data analog dari transducer (Load cell, wave probe, Displasemen transducer) menjadi data digital, yang diproses dengan menggunakan piranti lunak DAS 1600 dan AOS 1600. Dengan perangkat ini maka dapat dibuat program untuk mengolah hasil pengukuran sehingga hasil pengukuran dapat ditampilkan melalui printer

baik dalam bentuk digital atau grafik. Untuk ADC dapat digunakan 16 channel dan DAC 2 channel.

### **5. Probe Gelombang**

Probe yang digunakan mempunyai panjang 400 mm, terbuat dari baja tahan karat yang dilapisi alumunium. Tahanan dari kabel yang digunakan maksimum satu ohm.

### **6. Pembangkit Gelombang**

Berfungsi sebagai pembuat / pembangkit gelombang yang bekerja berdasarkan tenaga hidrolis yang dihasilkan oleh motor listrik dengan sistim pendingin luar menggunakan minyak. Pembangkit gelombang ini di kendalikan oleh satu perangkat pengontrol yang terdiri dari atas :

#### **1. Unit Pengontrol Pusat**

Menggunakan satu komputer Mikro HP86B untuk menghasilkan karakteristik gelombang yang diharapkan (tinggi, frekwensi dan panjang gelombang).

#### **2. Pembangkit Signal**

Berfungsi untuk membangkitkan signal dan menyimpannya dalam memori kemudian membangkitkan signal referensi untuk pengontrol.

#### **3. Silinder kerja dihubungkan dengan katup servo dengan dua tansducer.**

Satu untuk displasmen dan yang satu untuk perbedaan tekanan.

#### **4. Unit Pengontrol Servo**



Dipasang dengan Proportional Integrated Differentiator (PID) atau pengontrol linear integral dan diferensial dan dua buah amplifier pengukur.

5. Minyak atau air pendingin digunakan untuk mendinginkan minyak hidrolis yang dilengkapi saklar otomatis dan manual. Kerja silinder dapat menghasilkan gaya 20 KN dengan tekanan kerja 210 bar dan amplitudo 200 mm. Tenaga hidrolis yang dihasilkan oleh motor diteruskan ke bagian flap yang terletak di bagian ujung kolam dan tercelup dalam air untuk menghasilkan gelombang. Untuk mengurangi / memperkecil terjadinya gelombang pantul, maka di setiap ujung kolam dan di belakang flap dipasang peredam gelombang yang terbuat dari bahan ijuk yang dirangkai dengan kawat ram - raman.

## 7. Wave Gauge (Pengukur Gelombang)

Pengukur gelombang yang digunakan dalam percobaan ini adalah *Seasim Auto Compensating*. Pada pengoperasiannya alat ini mempunyai dua mode, yaitu mode otomatis dan mode statik/kalibrasi, beberapa spesifikasi utama dari alat ini diantaranya adalah :

- |                     |   |
|---------------------|---|
| Output              | : $\pm 10$ V ke dalam 10 ohm, melalui BNC socket yang ada di sisi belakang. |
| Frekuensi gelombang | : 0.2 - 10 Hz (pada mode auto)  |
| Selang pengukuran   | : 0 - 10 Hz (pada mode statik)  |
| Power suply         | : 220 V - 240 V 50 Hz/110 V 60 Hz   |

Kelinieran : Rata-rata 95 % pada rangkaian probe 1 ohm.  
99 % pada modul terisolasi.

## 8. Load Cell

Alat ini berfungsi sebagai pengukur besarnya perubahan beban yang diakibatkan oleh beban gelombang, adapun prinsip kerja hampir sama dengan strain gauge dan dapat dijelaskan sebagai berikut <sup>(5)</sup>.

1. Elemen pengukuran adalah pegas baja dengan 4 strain gauge di dalamnya.
2. Dua dari empat strain gauge akan mengalami tarik dan dua strain gauge yang lain akan mengalami tekanan ketika pegas pengukuran dibebani dalam arah pengukuran.
3. Pada waktu pegas dibebani dalam arah pengukuran (dalam hal ini gaya tarik aksial karena gerakan surging), gaya ini terdistribusi pada pegas dimana 4 strain gauge terpasang.
4. Akibat beban yang diterima pegas, pegas mengalami regangan. Prinsip ini mengikuti hukum *Hooke*, yaitu apabila suatu elemen menerima beban gaya, maka elemen tersebut akan mengalami perubahan panjang yang dinyatakan dengan angka strain, angka strain menunjukkan perbandingan panjang antara panjang elemen dengan panjang semula. \*
5. Regangan pegas menyebabkan perubahan tahanan pada 4 strain gauge. 2 strain gauge mengalami perubahan tahanan karena tarik dan



dua strain gauge yang lain mengalami perubahan tahanan karena tekan.

6. Besarnya perubahan tahanan pada strain gauge dikirim ke amplifier untuk diperbesar sinyalnya.
7. Dari amplifier besarnya perubahan tahanan yang telah diperbesar sinyalnya dikirim ke Digital Analog System (DAS) 1600 atau ke stripchart recorder, sehingga besarnya perubahan dapat diketahui.

Skema dari pada model dan semua perlengkapannya dapat dilihat pada gambar 3.5.

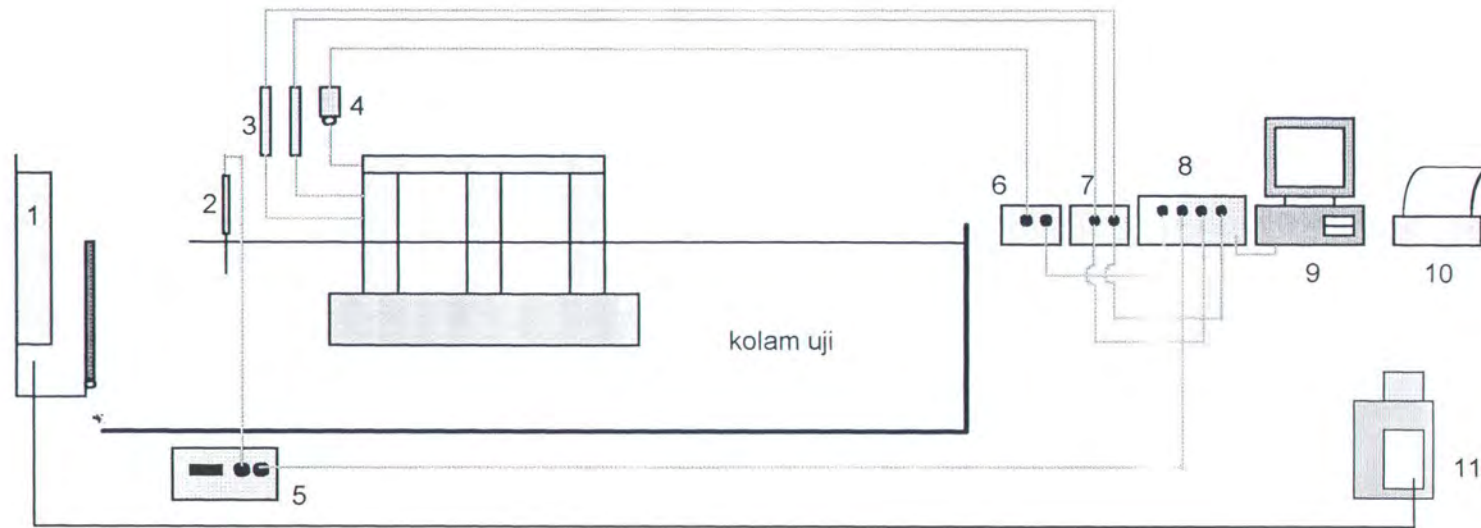

Keterangan gambar :

- |                            |                              |               |
|----------------------------|------------------------------|---------------|
| 1. Wave maker              | 5. Seaisim amplifier         | 9. Komputer   |
| 2. Wave probe              | 6. Load cell amplifier (HBM) | 10. Printer   |
| 3. Displacement transducer | 7. Trimmeter amplifier       | 11. Dyna test |
| 4. Load cell               | 8. DAC/ADC                   |               |

Gambar 3.5. Skema Rangkaian Model dan Peralatan Percobaan



### 3.2.3. Kalibrasi

Setelah peralatan uji terpasang seluruhnya, maka untuk menentukan gaya yang setara dengan volt yang terukur pada Digital Analog System (DAS) 1600 dilakukan kalibrasi, kalibrasi ini dilakukan load cell dan displasemen transduser.

#### 3.2.3.1. Kalibrasi Gelombang

Kalibrasi gelombang dilakukan untuk mengetahui tinggi gelombang yang terjadi selama percobaan, sekaligus melakukan pengecekan terhadap gelombang yang terjadi apakah sesuai atau tidak antara input yang dikehendaki dengan gelombang yang keluar dari pembangkit gelombangnya (*wave maker*).

Pada kalibrasi ini menggunakan seasim amplifier dan probe yang saling berhubungan. Wave gauge dipasang ke posisi 'auto mode' dan kemudian saklar dihidupkan. Tunggu beberapa saat sampai voltase yang ditunjukkan voltameter menunjukkan angka nol (atau mendekati nol), jika ini sudah tercapai, wave probe diubah ke posisi 'static mode'. Probe dimasukan kedalam kolam uji secukupnya, dan diukur kondisi nolnya. Kemudian setelah itu diangkat 5 cm ke atas dan dicatat hasil pembacaannya. Setelah itu diturunkan sedalam 5 cm dari posisi nolnya dan dicatat juga hasil pembacaannya. Dalam menggerakkan probe kearah atas dan bawah ini dilakukan secara perlahan-lahan agar tidak mengganggu ketenangan permukaan air. Semua hasil pengukuran dapat dilihat melalui layar monitor DAS 1600.

### 3.2.3.2. Kalibrasi Loadcell

Langkah-langkah kalibrasi loadcell untuk mengukur beban yang diterima benda uji akibat gelombang untuk arah head sea adalah sebagai berikut:

1. Kabel output dari load cell dihubungkan ke amplifier loadcell, lalu dari amplifier dihubungkan ke ADC/DAC Interface dengan menggunakan program DAS 1600.
2. Pada posisi netral, letak model harus even keel. Dan gain pada amplifier diatur agar menunjukkan angka nol.
3. Kalibrasi dilakukan dengan menggantung beban pada load cell. Beban yang digunakan adalah 0, 50, 100, 200, dan 1000 gram, dan dilakukan sampai 3 kali perlakuan beban di atas.
4. Catat semua hasil kalibrasi dan pemakaian konstanta kalibrasi (CC) yang digunakan.
5. Model semisubmersible siap untuk di uji.

### 3.2.3.3. Kalibrasi Displasemen Tranduser

Langkah-langkah kalibrasi displasemen tranduser untuk mengukur simpangan surging yang terjadi selama percobaan akibat gelombang untuk arah head sea adalah sebagai berikut :

1. Kabel output displasemen tranduser dihubungkan ke amplifier trimmeter, lalu dari amplifier dihubungkan ke ADC/DAC Interface dengan menggunakan program DAS 1600.



2. Pada posisi netral, letak model harus even keel. Dan gain pada amplifier diatur agar menunjukkan angka nol.
3. Proses kalibrasi dilakukan dengan cara menempatkan bandul dalam displasemen transduser pada tengah-tengah batang displasemen transduser sebagai posisi 0, lalu tali ditarik 5 cm ke bawah dan 5 cm ke atas.
5. Catat semua hasil kalibrasi.
6. Model semisubmersible siap untuk di uji.

#### **3.2.3.4. Kalibrasi Konstanta Pegas**

Setelah konstanta pegas ditentukan melalui proses perhitungan gaya yang mengenai model oleh gelombang yang bervariasi terhadap periode dan tinggi gelombang, serta sarat model (dibahas pada lampiran), dilakukan pengkalibrasian pegas yang telah tersedia. Untuk menentukan konstanta pegas, gaya yang mengenai model diambil yang paling kecil, agar gerakan osilasi model dapat terlihat secara jelas dan dapat diukur oleh peralatan ukur (load cell dan displasemen transducer). Langkah-langkah pengkalibrasian pegas dilakukan sebagai berikut :

1. Beberapa pegas yang tersedia diukur panjang awalnya.
2. Setelah itu dilakukan pembebanan pada setiap pegas dengan beban yang telah diketahui beratnya, dimana variasi pembebanan dilakukan sebanyak 3 (tiga) kali.
3. Tiap kali dilakukan pembebanan, maka perlu dicatat pertambahan panjang yang terjadi dari pegas tersebut

4. Data pembebanan dan penambahan panjang dari tiap pegas yang telah diukur diplotkan ke dalam suatu grafik agar dapat dilihat kelinearannya.
5. Pegas siap digunakan untuk percobaan.

#### 3.2.4. Penentuan Parameter Gelombang

Karena dalam penelitian ini menggunakan beban gelombang, sudah barang tentu sebelumnya harus ditentukan dulu karakteristik gelombang yang akan dipakai. Penentuan parameter gelombang ini dengan asumsi bahwa model akan digunakan di laut dalam, beban yang digunakan dominan beban inersia, dan menggunakan teori gelombang linier. Untuk teori gelombang linier pada laut dalam syarat dan karakteristik gelombangnya sebagai berikut :

$$kd > \pi, \quad d/\lambda > 0.5, \quad d/(gT^2) > 0.08$$

$$\text{panjang gel. } \lambda = gT^2/2\pi$$

Dominasi beban inersia bila  $H/D < 1.5$

Sedangkan pemilihan teori gelombang yang sesuai dapat dilihat pada grafik *region of validity* Chakrabarti S.K. (1987) yang merupakan fungsi dari  $H/T^2$  (ft/sec<sup>2</sup>) dan  $d/T^2$  (ft/sec<sup>2</sup>).

Untuk gerakan surging\* dimensi struktur yang paling diperhatikan adalah dimensi kolom yang mempunyai diameter luar pipa = 80 mm, kedalaman kolam 190.2 cm dan rencana tinggi gelombang 2 cm dan 4 cm. Rentang periode yang digunakan adalah 1.2 - 2.0 detik dengan



inremen periode 0.1. Pada lampiran A dapat dilihat bahwa karakteristik model memenuhi untuk laut dalam, dominasi beban inersia dan teori gelombang yang dipakai adalah teori gelombang linier.

### 3. 3. PROSES PERCOBAAN

Model semisubmesible diletakkan dan diatur sesuai sarat yang diinginkan. Kedudukan model harus even keel, sedangkan gelombang yang dipakai dalam arah head sea.

Setelah kalibrasi dilakukan maka model semisubmersible siap diuji dan gelombang siap dibangkitkan. Dalam pengujian ini, untuk membangkitkan gelombang yang sesuai dengan karakteristik yang diinginkan, digunakan komputer HP 36 B yang dihubungkan dengan perangkat *Analog System Dyna Test* yang akan menggerakkan wave maker. Adapun urutan pengerjaan pengujian ini adalah sebagai berikut :

1. Selama proses pengujian, masing-masing tahap dilakukan perekaman data dengan jumlah dan rentang waktu yang sama, yang akan dibaca oleh load cell, displasemen tranduser dan probe gelombang.
2. Jumlah data yang direkam untuk tiap langkah pengujian berjumlah 200 buah dengan rentang waktu pencatatan selama 20 detik.
3. Tiap-tiap pengujian nama file dan konstanta kalibrasi yang digunakan dicatat.

### 3. 4. ANALISA DATA HASIL PERCOBAAN

Setelah percobaan selesai dilakukan, maka langkah selanjutnya adalah melakukan analisa terhadap data yang diperoleh selama percobaan. Data-data tersebut dalam hal ini adalah hasil pembacaan load cell dikalikan *konstanta kalibrasi* (CC) akhirnya bisa diperoleh besarnya gaya, dari displasemen transduser dikalikan faktor kalibrasi akan diperoleh simpangan gerakan surging yang terjadi dan dari seasim dikalikan faktor kalibrasi akan diketahui tinggi gelombang percobaan.

Untuk mengetahui besarnya koefisien redaman, hasil pencatatan dari displasemen transduser dimasukkan ke dalam persamaan simpangan, kecepatan dan percepatan struktur akibat gerakan surging. Dimana dari persamaan simpangan diturunkan terhadap waktu akan ditemukan kecepatan dan dari kecepatan diturunkan terhadap waktu akan ditemukan percepatan. Persamaan tersebut dibawah ini.

$$x = x_0 \sin \omega t \quad (3.1)$$

$$\dot{x} = \frac{dx}{dt} = x_0 \omega \cos \omega t \quad (3.2)$$

$$\ddot{x} = \frac{d^2x}{dt^2} = -x_0 \omega^2 \sin \omega t \quad (3.3)$$

Koefisien redaman dicari dengan cara memasukkan gaya yang sefase dengan kecepatan ke dalam persamaan dinamika benda terapung (dalam bab 2). Kemudian dengan menggunakan prinsip beda fase, seperti yang ditunjukkan dalam gambar 3.6, maka besarnya koefisien redaman dapat diketahui.



Adapun besarnya koefisien redaman diketahui dengan cara membagi gaya yang keluar dari eksperimen dengan komponen kecepatan sebagai berikut :

$$b = \frac{F_x}{x_0 \omega \cos \omega t} \quad (3.4)$$

karena pada saat kecepatan maksimum besarnya  $\cos \omega t = 1$ , maka persamaan (3.4) menjadi :

$$b = \frac{F_x}{x_0 \omega} \quad (3.5)$$

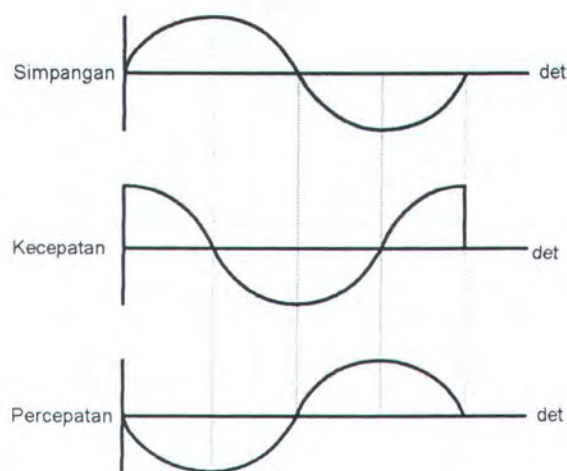

Gambar 3.6. Beda fase antara simpangan kecepatan, dan percepatan

Hasil koefisien koefisien redaman tersebut kemudian dibuat dalam bentuk grafik dalam hubungannya dengan frekwensi gelombang pada setiap kondisi sarat yaitu pada sarat 6.5 cm, 11 cm, dan 22.4cm. Hasil percobaan kemudian dibandingkan perhitungan dengan hasil perhitungan secara teori (teori strip) atau dengan penelitian penulis lain yang telah

dipublikasikan kemudian dianalisa. Sebagai langkah terakhir adalah membuat kesimpulan dari hasil percobaan yang telah dilakukan.

### **3. 5. PEMBUATAN LAPORAN AKHIR**

Setelah semua proses percobaan dan analisa data telah selesai dilakukan, langkah terakhir adalah menyusun laporan akhir mengenai semua kegiatan yang telah dilakukan.



## BAB IV

### ANALISA DAN PEMBAHASAN

#### 4. 1. HASIL PERHITUNGAN TEORI KOEFISIEN REDAMAN

Perhitungan secara teori dalam menentukan koefisien redaman merupakan perumusan dari permasalahan yang telah dijelaskan dalam bab II. Dalam perhitungan koefisien redaman untuk semua kondisi sarat (6.5, 11.0, dan 22.4 cm) menggunakan teori strip. Besarnya hasil perhitungan tersebut dapat dilihat pada lampiran C. Resume hasil perhitungan koefisien redaman tersebut pada setiap kondisi sarat di atas dapat dilihat pada tabel 4.1. Sedangkan grafik hasil perhitungan secara teori dapat dilihat pada gambar 4.1, 4.2, dan 4.3.

Tabel 4.1. Resume Hasil Koefisien Redaman Teori Strip

No	T (dt)	$\omega$ (rad/dt)	b T = 6.5 cm	b T = 11 cm	b T = 22.4 cm
1	1.2	5.24	5.482	0.724	0.377
2	1.3	4.83	4.608	0.695	0.351
3	1.4	4.49	4.334	0.659	0.358
4	1.5	4.19	4.231	0.604	0.316
5	1.6	3.93	3.792	0.537	0.297
6	1.7	3.7	3.104	0.499	0.266
7	1.8	3.49	2.634	0.323	0.245
8	1.9	3.31	2.125	0.304	0.204
9	2	3.14	1.882	0.256	0.178

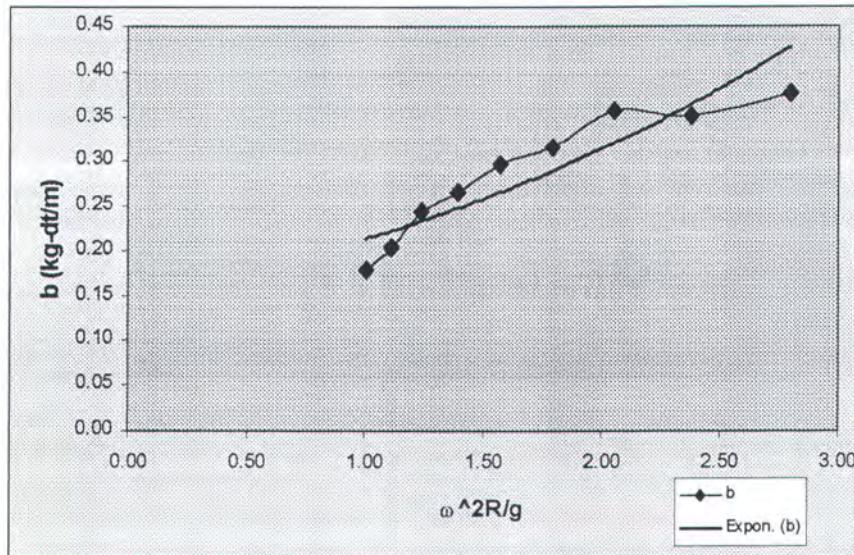

Gambar 4.3. Grafik Koefisien Redaman  
Kondisi sarat 22.4 cm

Hasil perhitungan koefisien redaman yang dihitung dengan menggunakan teori strip ini mempunyai nilai peningkatan koefisien redaman seiring dengan meningkatnya frekwensi gelombang.

## 4. 2. HASIL PERCOBAAN

### 4.2.1. Hasil Kalibrasi

Kalibrasi yang dilakukan pada percobaan ini bertujuan untuk mengetahui besarnya gaya, simpangan dan tinggi gelombang yang setara dengan volt yang terukur pada alat perekam percobaan (Digital Analog System-DAS 1600), serta untuk mengetahui besarnya konstanta pegas yang digunakan dalam percobaan. Kalibrasi tersebut dilakukan pada



beberapa alat pengukur yang digunakan pada percobaan, yaitu load cell, wave probe, displacement transducer, dan pegas.

### 1. Kalibrasi Load cell

Load cell yang digunakan dalam percobaan ini adalah jenis load cell dengan beban 2 kg. Ada dua cara kalibrasi load cell yaitu secara otomatis dan secara manual. Secara otomatis besarnya konstanta kalibrasi dapat dilihat pada amplifier pada saat load cell dikenai beban statis. Sedangkan secara manual proses kalibrasi dilakukan dengan menggunakan variasi beban statis seperti kalibrasi otomatis sebesar 0, 50, 100, 200, dan 1000 gram. Beban - beban tersebut digantungkan pada load cell kemudian diukur hasilnya pada alat perekam DAS-1600 berupa volt. Untuk satu jenis beban di atas dilakukan sampai tiga kali kalibrasi. Dalam tabel 4.2. dapat dilihat hasil kalibrasi load cell dari beberapa beban di atas.

Tabel 4.2. Hasil Kalibrasi Beban pada Load Cell

No	Beban (gr)	Analog (Volt)			Rata-rata	Cc	
		I	II	III		(Kg/V)	(N/V)
1	0	0.050	0.060	0.060	0.057	0.000	0.0
2	50	1.291	1.249	1.372	1.304	0.038	0.4
3	100	2.500	2.490	2.500	2.497	0.040	0.4
4	200	4.950	4.950	4.940	4.947	0.040	0.4
5	1000	9.300	9.080	9.380	9.253	0.100	1.0

Dari hasil kalibrasi manual dan otomatis tersebut, dapat diketahui besarnya gaya yang terjadi pada model. Ada 2 cara untuk mengetahui besarnya gaya tersebut, yaitu :

1. Hasil pembacaan data dari load cell dikalikan dengan Cc manual (Kg/V) dan percepatan gravitasi sebesar  $9.81 \text{ m/dt}^2$ . sebagai contoh, harga pembacaan dari load cell sebesar 4 volt, maka gaya terjadi adalah :

$$4 \times 0.04 \times 9.81 = 1.57 \text{ Newton}$$

2. Dengan penggunaan Cc otomatis (N/V) :

$$4 \times 0.4 = 1.6 \text{ Newton}$$

Hasil dari kedua cara tersebut mempunyai harga konstanta kalibrasi load cell (Cc) yang mendekati, maka untuk mempermudah proses perhitungan selanjutnya digunakan konstanta kalibrasi otomatis. Pemakaian konstanta kalibrasi load cell tersebut untuk setiap percobaan dapat dilihat pada lampiran E.

## 2. Kalibrasi Trimmeter

Kalibrasi pada trimmeter dilakukan untuk mengetahui besarnya simpangan yang terukur dalam percobaan. Hasil yang didapat disajikan dalam tabel 4.3. di bawah ini.

Tabel 4.3. Hasil Kalibrasi pada Trimmeter

Posisi	Tinggi (cm)	Trimmeter 1 (Volt)	Trimmeter 2 (Volt)
1	0	0	0
2	1	0.297	0.37
3	2	0.59	0.741
4	5	1.48	1.825

Dari hasil kalibrasi di atas besarnya konstanta kalibrasi diperoleh dengan merata-rata dari hasil setiap posisinya. Sehingga diperoleh



konstanta kalibrasi untuk trimmeter 1 sebesar 3.37 cm/V, dan untuk trimmeter 2 sebesar 2.7 cm/V. Tetapi data hasil percobaan menunjukkan terjadinya kelonjakan volt pada trimmeter 1, sehingga tidak diikuti dalam proses perhitungan.

### 3. Kalibrasi Gelombang

Kalibrasi gelombang dimaksudkan untuk mengetahui besarnya tinggi gelombang yang dihasilkan selama proses percobaan. Kalibrasi ini dilakukan pada seasim amplifier dan pengukur gelombang (*Wave probe*) yang saling berhubungan. Kalibrasi dilakukan dengan cara menggerakkan wave probe ke atas dan kebawah kemudian dicatat hasil yang terukur. hasil kalibrasi gelombang dapat dilihat dalam tabel 4.4.

Tabel 4.4. Hasil Kalibrasi Gelombang

Posisi	Tinggi (cm)	Seasim (Volt)
atas	5	2.475
normal	0	0
bawah	5	-2.475

### 4. Kalibrasi Pegas

Kalibrasi pegas dimaksudkan untuk mengetahui besarnya konstanta pegas yang digunakan dalam percobaan. Dasar yang digunakan sebagai acuan adalah besarnya gaya eksitasi gelombang yang ditentukan dengan menggunakan pendekatan teori Morison, seperti yang telah

dijelaskan dalam bab II. Dari gaya eksitasi tersebut (Lampiran D), besarnya konstanta pegas didasarkan pada besarnya gaya yang terkecil. Hal ini dimaksudkan agar dalam percobaan, model dapat tetap bergerak dan terukur gaya dan simpangannya jika diperlakukan gaya yang terbesar.

Untuk mendapatkan nilai konstanta pegas yang diharapkan, yaitu dengan membagi gaya eksitasi terkecil tersebut dengan simpangan yang diinginkan. Simpangan ini didasarkan pada kemampuan displacement transducer yang digunakan, dan percobaan-percobaan yang pernah dilakukan di Laboratorium Hidrodinamika.

Dalam percobaan ini menggunakan dua buah pegas dengan karakteristik masing-masing panjang awal  $L_0 = 1.715$  cm dan diameter = 0.45. Hasil kalibrasi pegas dapat dilihat pada tabel 4.5.

Tabel 4.5. Hasil Kalibrasi Pegas

Beban		L1 (cm)		Regangan (cm)		Cc (N/cm)	
(gr)	(N)	Pegas 1	Pegas2	Pegas 1	Pegas2	Pegas1	Pegas2
50	0.491	2.442	2.465	0.727	0.75	0.675	0.654
100	0.981	3.179	3.197	1.464	1.482	0.67	0.662
200	1.96	4.649	4.515	2.934	2.8	0.668	0.7

#### 4.2.2. Pengolahan Data Hasil Percobaan

Keluaran hasil percobaan pada setiap kondisi sarat merupakan hasil pembacaan dari load cell, trimmeter dan seasim. Pada setiap kali proses percobaan dihasilkan 200 data dengan waktu pencatatan selama 20 dt. Sehingga frekwensi pencatatannya adalah 10 Hz. Harga yang



digunakan dalam perhitungan adalah harga rata-rata dari beberapa nilai puncak. Proses pengolahan data percobaan dalam menentukan koefisien redaman untuk setiap pengujian secara lengkap dapat dilihat pada lampiran F.

#### 4.2.3. Penentuan Koefisien Redaman Hasil Percobaan

Dari pembacaan data hasil percobaan didapat gaya dan simpangan yang terukur pada setiap kondisi. Kemudian setelah dikalikan dengan masing-masing konstanta kalibrasi didapatkan gaya dan simpangan dalam Newton dan meter. Koefisien redaman  $b$  diperoleh dengan cara membagi gaya yang terukur dengan kecepatan struktur. Dimana kecepatan struktur tersebut merupakan perkalian antara simpangan dan frekwensi gelombang (bab-III). Proses pengolahan data dan perhitungan koefisien redaman dapat dilihat pada lampiran F, secara garis besar dapat dilihat pada tabel 4.6.

Tabel 4.6. Resume Koefisien Redaman Percobaan

Sarat 6.5 cm

No	Periode (dt)	Frekwensi (rad/dt)	b H = 4 cm	b H = 2 cm
1	1.2	5.236	0.957	0.2966
2	1.3	4.833	2.5304	0.2716
3	1.4	4.488	4.1009	0.3922
4	1.5	4.189	3.5506	0.3304
5	1.6	3.927	5.2597	0.5153
6	1.7	3.696	10.1938	0.4718
7	1.8	3.4907	1.4318	0.7227
8	1.9	3.3069	0.191	0.7621
9	2	3.142	0.1422	0.4846

Tabel 4.7. Resume Koefisien Redaman Percobaan  
Sarat 11.0 cm

No	Periode (dt)	Frekwensi (rad/dt)	b H = 4 cm	b H = 2 cm
1	1.2	5.236	0.2465	0.2596
2	1.3	4.833	0.3029	0.2516
3	1.4	4.488	0.5436	0.3332
4	1.5	4.189	0.9721	0.401
5	1.6	3.927	2.0854	0.3598
6	1.7	3.696	4.83	0.3904
7	1.8	3.4907	6.1797	0.5364
8	1.9	3.3069	4.8176	0.6123
9	2	3.142	6.4714	0.5694

Tabel 4.8. Resume Koefisien Redaman Percobaan  
Sarat 22.4 cm

No	Periode (dt)	Frekwensi (rad/dt)	b H = 4 cm	b H = 2 cm
1	1.2	5.236	1.5798	0.3641
2	1.3	4.833	1.8992	0.3603
3	1.4	4.488	3.0917	0.4967
4	1.5	4.189	4.9956	0.5771
5	1.6	3.927	8.5427	1.001
6	1.7	3.696	13.5368	1.5441
7	1.8	3.4907	14.6372	2.8343
8	1.9	3.3069	16.0964	4.5116
9	2	3.142	17.0989	0.3501



### 4. 3. PEMBAHASAN

#### 4.3.1. Pengaruh Frekwensi, Sarat, Dan Tinggi Gelombang Terhadap Koefisien Redaman

Dari hasil analisa perhitungan baik secara teori dan analisa hasil percobaan dapat digambarkan hubungan antara frekwensi gelombang dan besaran koefisien redaman.

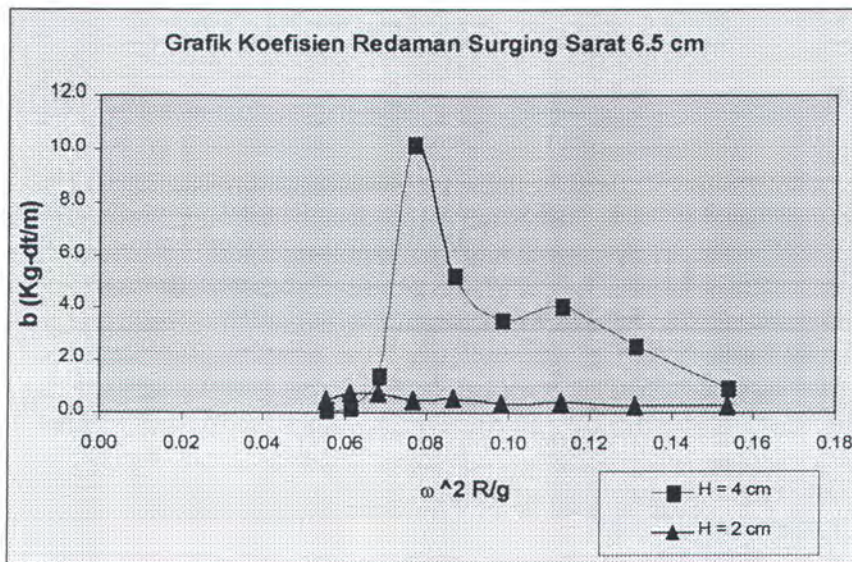

Gambar 4.4. Grafik b Perobaan Kondisi Sarat 6.5 cm

*Untuk sarat 6.5 cm* seperti yang terlihat pada gambar 4.4, untuk tinggi gelombang 4 cm pada rentang frekwensi 3.14 - 3.5 rad/dt menunjukkan koefisien redaman antara 0.14 - 1.43 k-dt/m. Tetapi pada frekwensi 3.696 rad/dt terjadi lonjakan koefien redaman mencapai 10.1938 kg-dt/m. Pada rentang frekwensi 3.93 - 5.24 rad/dt koefisien redaman mengalami penurunan antara 5.26 - 0.96 kg-dt/m.



Untuk tinggi gelombang 2 cm koefisien redaman yang dihasilkan berkisar antara 0.2966 - 0.7621 kg-dt/m. Pada rentang periode terjadi angka kenaikan dari 0.4846 - 0.7621 kg-dt/m. Tetapi pada sisa frekwensi gelombang yang ada menunjukkan angka penurunan, meskipun frekwensi gelombang tersebut besarnya semakin meningkat.

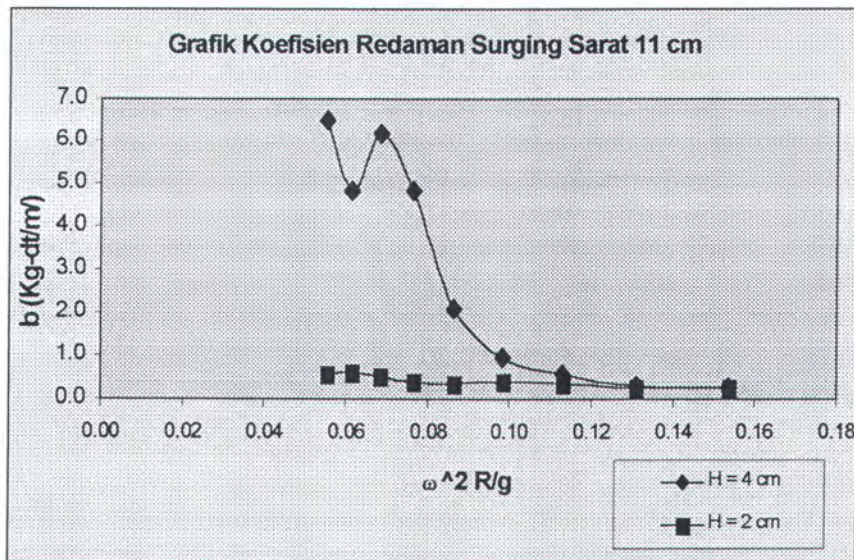

Gambar 4.5. Grafik b Percobaan Kondisi Sarat 11.0 cm

**Untuk sarat 11 cm** (gambar 4.5) dan tinggi gelombang 4 cm pada rentang frekwensi 3.14 - 3.93 rad/dt menunjukkan penurunan hasil koefisien redaman antara 6.47 - 2.09 kg-dt/m. Untuk rentang frekwensi 4.19 - 5.24 rad/dt terjadi penurunan yang tajam, yaitu berkisar 0.97 - 0.25 kg-dt/m. Trend garis yang ditunjukkan terdapat penurunan koefisien redaman meskipun frekwensi gelombang semakin meningkat. Untuk tinggi gelombang 2 cm pada rentang frekwensi 3.14 - 5.24 rad/dt menunjukkan penurunan koefisien redaman antara 0.6 - 0.26 kg-dt/m.



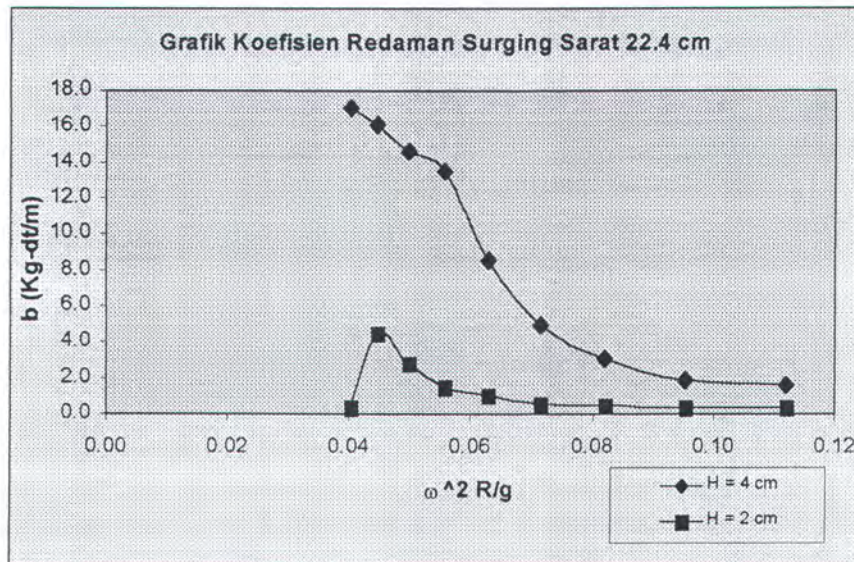

Gambar 4.6. Grafik b Percobaan Kondisi Sarat 22.4 cm

**Untuk sarat 22.4 cm** (gambar 4.6) untuk tinggi gelombang 4 cm pada rentang frekwensi 3.14 - 5.24 rad/dt terjadi penurunan nilai koefisien redaman yang tajam, yaitu berkisar antara 17.1 - 1.58 kg-dt/m. Untuk tinggi gelombang 2 cm pada rentang frekwensi 3.14 - 3.31 rad/dt besarnya koefisien redaman mengalami peningkatan dari 0.35 - 4.51 kg-dt/m. Tetapi untuk rentang frekwensi berikutnya, yaitu 3.5 - 5.24 rad/dt, besarnya koefisien redaman mengalami penurunan antara 2.83 - 0.36 kg-dt/m.

#### 4.3.2. Perbandingan Hasil Percobaan Koefisien Redaman Dengan

##### Teori

Besaran koefisien redaman hasil percobaan dan hasil dari perhitungan secara teori dengan menggunakan teori strip kemudian digambarkan dalam satu grafik untuk dilakukan analisa.

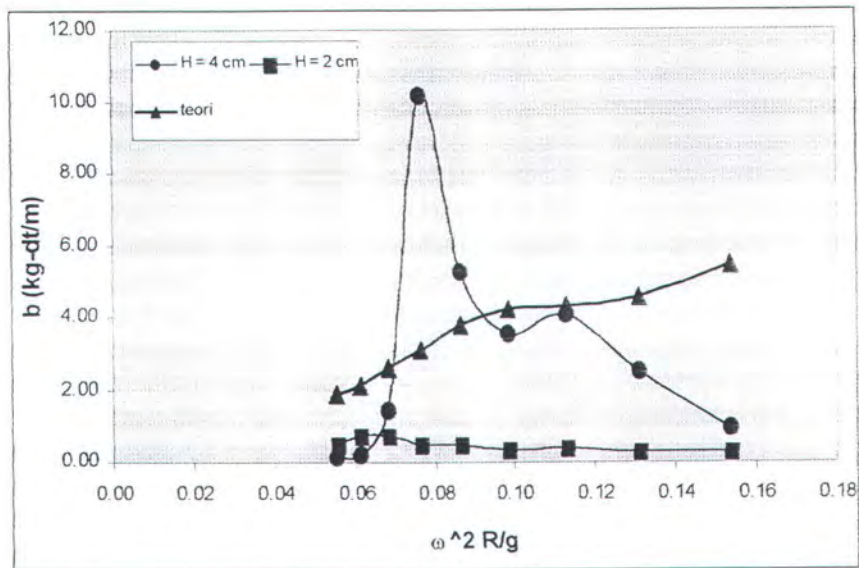

Gambar 4.7. Perbandingan Koefisien Redaman Hasil Percobaan Versus Koefisien Redaman Teori Strip Kondisi Sarat 6.5 cm.

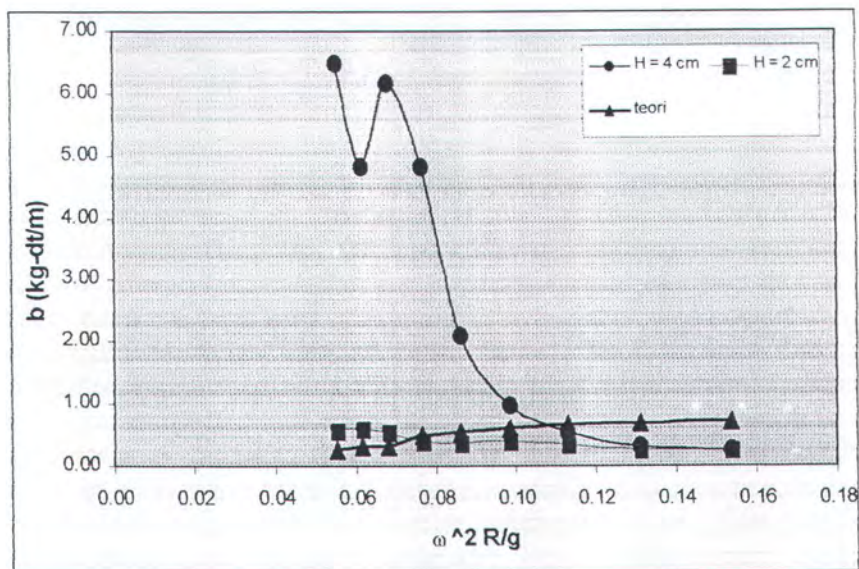

Gambar 4.8. Perbandingan Koefisien Redaman Hasil Percobaan Versus Koefisien Redaman Teori Strip Kondisi Sarat 11 cm



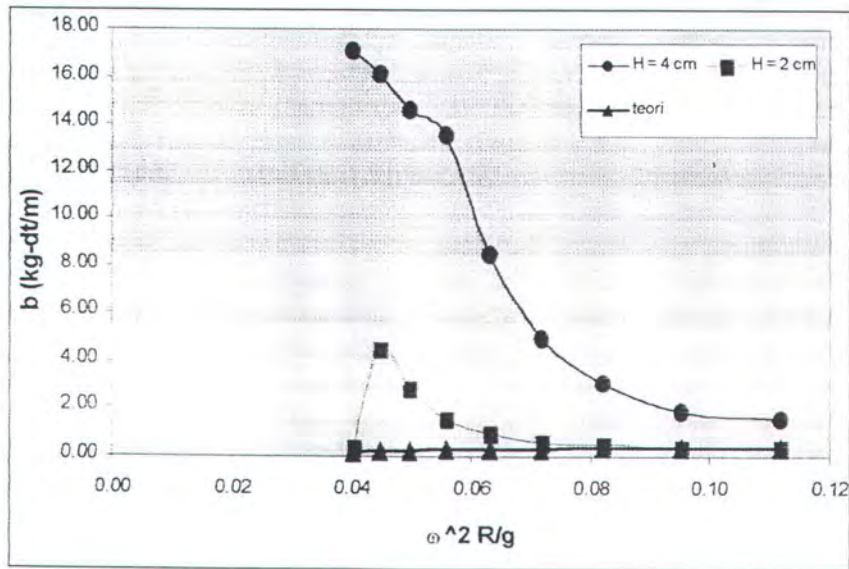

Gambar 4.9. Perbandingan Koefisien Redaman Hasil Percobaan Versus Koefisien Redaman Teori Strip Kondisi Sarat 22.4 cm

1. **Sarat 6.5 cm** (gambar 4.7) ; pada sarat ini menunjukkan adanya perbedaan hasil koefisien redaman percobaan dan koefisien redaman hasil perhitungan teori strip. Hasil perhitungan dengan teori strip menunjukkan rentang 1.88 - 5.48 kg-dt/m. Koefisien redaman hasil percobaan untuk tinggi gelombang 4 cm berkisar antara 0.19 - 10.19 kg-dt/m, sedang untuk tinggi gelombang 2 cm berada dalam rentang 0.27 - 0.76 kg-dt/m. Tetapi secara kuantitatif menunjukkan trend garis yang relatif sama antara hasil percobaan dan hasil teori strip.
2. **Sarat 11 cm** (gambar 4.8) ; hasil koefisien redaman dengan teori strip menunjukkan harga 0.25 - 0.724 kg-dt/m. Sedang koefisien redaman hasil percobaan untuk tinggi gelombang 4 cm menunjukkan rentang 0.2465 - 6.4714 kg-dt/m. Untuk tinggi gelombang 2 cm besarnya

koefisien redaman berkisar antara 0.2596 - 0.6123 kg-dt/m. Ini berarti terdapat perbedaan koefisien redaman antara hasil percobaan dan hasil teori.

3. **Sarat 22.4 cm** (gambar 4.9); hasil koefisien redaman dengan menggunakan teori strip dalam rentang 0.178 - 0.377 kg-dt/m. Sedangkan hasil percobaan untuk tinggi gelombang 4 cm dalam rentang 1.5798 - 17.0989 kg-dt/m, dan untuk tinggi gelombang 2 cm berkisar antara 0.3 - 4.5116 kg-dt/m. Pada sarat 22.4 cm ini terdapat perbedaan antara hasil teori strip dengan hasil percobaan.

Hasil percobaan ini menunjukkan perbedaan hasil yang secara kualitatif berbeda dengan hasil perhitungan teori strip. Tetapi untuk kondisi sarat 6.5 besarnya koefisien redaman percobaan tidak terlalu jauh jika dibanding dengan teori, dan trend garis yang dihasilkan secara kualitatif mempunyai kecenderungan yang relatif sama.

#### 4.3.3. Pengaruh Bentuk Konfigurasi T Terhadap Koefisien Redaman

Analisa dari perhitungan dengan teori strip menunjukkan terjadinya penurunan koefisien redaman seiring dengan bertambahnya sarat model yang digunakan. Pada sarat 6.5 cm menunjukkan harga koefisien redaman 1.88 - 5.48 kg-dt/m, sarat 11 cm menunjukkan rentang 0.25 - 0.72 kg-dt/m, dan pada sarat 22.4 cm menunjukkan rentang 0.17 - 0.38 kg-dt/m. Hal ini disebabkan karena bentuk dari pada model semisubmersible tidak homogen seperti bentuk kapal pada umumnya. Karena pada kapal luas permukaan yang terkena air semakin besar apabila sarat yang digunakan



lebih tinggi. Sedang bentuk model semisubmersible bentuknya heterogen, sehingga luas permukaan yang terkena air semakin mengecil dengan bertambahnya sarat.

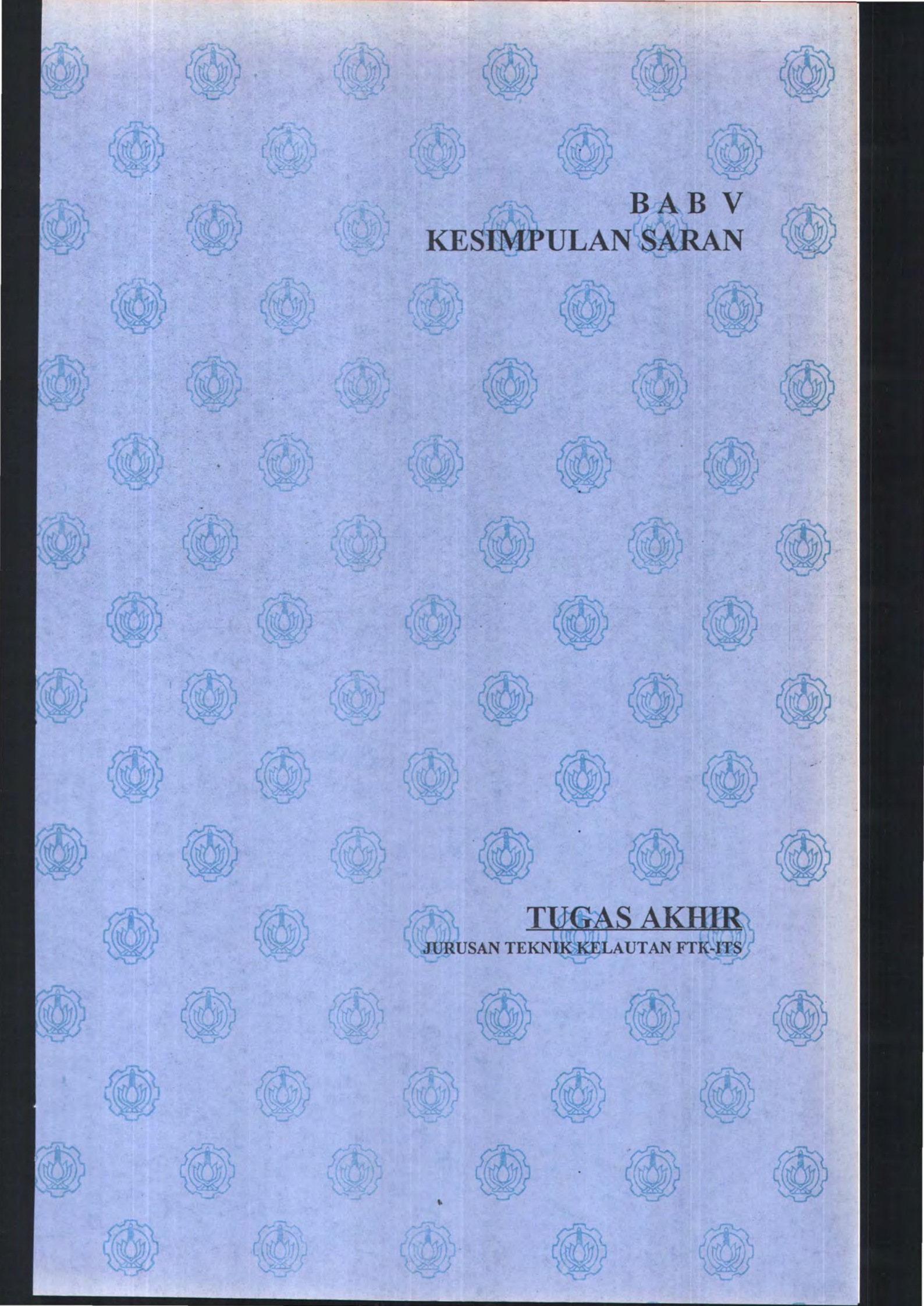

**BAB V**  
**KESIMPULAN SARAN**

**TUGAS AKHIR**  
**JURUSAN TEKNIK KELAUTAN FTK-ITS**



garis yang ditunjukkan relatif berbeda antara hasil percobaan dan hasil teori strip. Hal ini bisa dimengerti karena teori strip tersebut mendasarkan pada bentuk kapal pada umumnya, dimana memiliki bentuk yang homogen dan luas permukaan garis air yang semakin besar seiring dengan naiknya sarat. Tetapi pada struktur semisubmersible memiliki bentuk yang heterogen dan luas permukaan garis air yang semakin kecil seiring dengan naiknya sarat.

## 5. 2. SARAN

Berdasarkan pada percobaan yang telah dilaksanakan dan hasil yang telah dicapai, maka untuk penyempurnaan pengujian yang akan datang perlu diperhatikan :

1. Penyempurnaan setting model untuk percobaan sejenis selanjutnya, terutama masalah pengikatan, faktor gesekan, dan lain-lain untuk dapat dikurangi semaksimal mungkin tanpa mengurangi fungsi percobaan, agar didapat gerakan yang osilasi sempurna.
2. Penggantian peralatan yang digunakan dalam percobaan, mengingat peralatan yang digunakan mempunyai umur yang cukup lama. Sehingga terjadi penurunan nilai fungsi dan

kapasitasnya. Untuk hasil yang lebih sempurna paling tidak dilakukan kalibrasi ulang pada setiap peralatan.

3. Perlu dikembangkan studi dan penelitian mengenai koefisien hidrodinamis bahkan sampai analisa gerakan pada struktur semisubmersible, karena hasil penelitian mengenai semisubmersible atau silinder terapung masih kurang sekali dilakukan.



## DAFTAR PUSTAKA

1. Bhattacharya, R, (1978), *Dynamics of Marine Vehicles*, Jon Wiley & Sons Inc, New York.
2. Chakrabarti, S. K, (1987), *Hydrodynamics of Offshore Structures*, CBI Industries Inc, New York.
3. Faltinsen, O. M, (1990), *Sea Loads on Ships and Offshore Structures*, Departement of Marine Technology Norwegian Institute of Technology, Cambridge University Press, London.
4. Hooft, J. P, (1982), *Advanced Dynamics Of Marine Structures*, Maritime Research Institute Wageningen Netherlands, John Wiley & Sons, New York.
5. Hottinger Baldwin Messetechnik, *Operating Manual V1, Z3H2, Electrical Measurement of Mechanical Quantities, Cell and Force Transducer with Strain Gauge Measuring System*, HBM, Germany.
6. Le Mehaute, B, (1976), *An Introduction to Hydrodynamics and Water Waves*, Springer-Verlag, New York.
7. Mc. Cormick, M. E, (1973), *Ocean Engineering Wave Mechanics*, John Wiley & Sons, Toronto.
8. Mikkelsen, J. and Calisal, S. M, (1993), *An Experimental Study of Hydrodynamics of Cylindrical Structures*, Marine Structures,



DEPARTEMEN PENDIDIKAN DAN KEBUDAYAAN  
INSTITUT TEKNOLOGI SEPULUH NOPEMBER  
FAKULTAS TEKNOLOGI KELAUTAN  
JURUSAN TEKNIK KELAUTAN

Kampus ITS - Sukolilo, Surabaya 60111 Telp. 5947254, 597274 psw. 144 Telex 34224 Fax 5947254

TUGAS AKHIR ( OE.1702 )

NO. : 088/PT.12.FTK4.H8/Q/96

MATA KULIAH : TUGAS AKHIR  
NOMOR MATA KULIAH : OE.1702  
NAMA MAHASWA : Adi Wirawan H.  
NOMOR POKOK : 4392100007  
TGL.DIBERIKAN TUGAS : 17 Juli 1996  
TGL.SELESAINYA TUGAS : 17 Januari 1997  
DOSEN PEMBIMBING : 1. Ir. M. Murtedjo, M.Eng  
2. Ir. Arief Suroso, M.Sc

THEMA / URAIAN / DATA-DATA YANG DIBERIKAN / JUDUL TUGAS AKHIR :

STUDI EKSPERIMENTAL PENENTUAN KOEFISIEN REDAMAN PADA SUATU MODEL SEMISUBMERSIBLE AKIBAT GERAKAN SURGING

DIBUAT RANGKAP 4 :

- 1.Mahasiswa ybs.
- 2.Dekan FTK-ITS
- 3.Dosen Pembimbing
- 4.Arsip Jurusan .





Surabaya, 17 Juli 1996  
Ketua Jurusan ;  
  
Dr. Eko Budi Djatmiko, MSc.  
NIP. 181 407 592



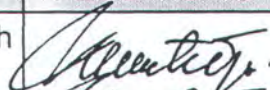
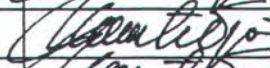

**LEMBAR PRESENTASI KONSULTASI TUGAS AKHIR**

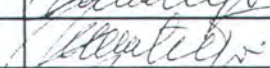
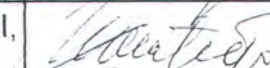
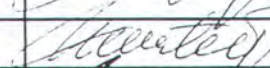
NAMA MAHASISWA : Adi Wirawan Husodo  
NOMOR POKOK : 4392 100 007  
NAMA DOSEN PEMBIMBING : 1. Ir. Mas Murtedjo, M. Eng  
2. Ir. Arief Suroso, M. Sc  
TUGAS DIMULAI : 17 Juli 1996  
TUGAS DISELESAIKAN : 1 Agustus 1997  
JUDUL TUGAS AKHIR : Studi Eksperimental Penentuan  
Koefisien Redaman Pada Suatu Model  
Semisubmersible Akibat Gerakan  
Surgung

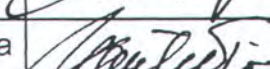
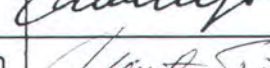
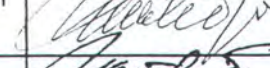
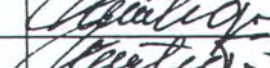
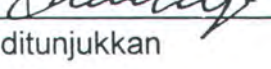
NO	TANGGAL	KONSULTASI MENGENAI	TANDA TANGAN DOSEN PEMBIMBING
1	25 / 7 / 96	Pendahuluan dan langkah-langkah percobaan	
2	2 / 8 / 96	Konsultasi setting model	
3	14 / 8 / 96	Konsultasi setting model dan Bab I	
4	7 / 9 / 96	Konsultasi dasar teori	
5	10 / 9 / 96	Konsultasi perumusan redaman	
6	26 / 5 / 97	Konsultasi setting model dan Bab I, II, dan III	
7	10 / 6 / 97	Konsultasi konstanta pegas	
8	26 / 6 / 97	Persiapan percobaan dan perlengkapan	
9	24 / 7 / 97	Perbaikan Bab I, II, III, dan analisa hasil percobaan	
10	25 / 7 / 97	Perbaikan analisa percobaan dan konsultasi Bab IV, V	
11	31 / 7 / 97	Perbaikan Bab IV dan V	
12	1 / 8 / 97	selesai	

Catatan : Lembar Presentasi dan Konsultasi ini harus ditunjukkan pada saat ujian tugas akhir



DEPARTEMEN PENDIDIKAN DAN KEBUDAYAAN  
INSTITUT TEKNOLOGI SEPULUH NOPEMBER  
FAKULTAS TEKNOLOGI KELAUTAN  
**PROGRAM STUDI TEKNIK KELAUTAN**

Kampus ITS - Sukolilo, Surabaya 60111 Telp. 5947254, 597274 psw. 144 Telex 34224 Fax 5947254

**LEMBAR PRESENSI KONSULTASI TUGAS AKHIR**

NAMA MAHASISWA : ADI WIRAWAN HUSODO  
NOMOR POKOK : 4392.100.007  
NAMA DOSEN PEMBIMBING : Ir. M. MURTERIO, M.Eng. & Ir. ARIEF SUROSO, M.Sc.  
TUGAS DIMULAI : 17 JULI 1996  
TUGAS DISELESAIKAN :  
JUDUL TUGAS AKHIR : STUDI EKSPERIMENTAL PENENTUAN  
KOEFSIAN REDAMAN PADA SUATU MODEL  
SEMISUBMERSIBLE AFIBAT GERAKAN  
SURUNG.

No	Tanggal	Konsultasi Mengenai	Tanda -Tangan
1	29/07/97	Bab. I, II, III	
2	4/08/97	Bab. IV	
3			
4			
5			
6			
7			
8			
9			
10			

Catatan : Lembar Presensi ini harus ditunjukkan pada saat Ujian Tugas Akhir.



Tabel A.1.1. Validitas Laut Dalam dan Dominasi Beban Inersia

Periode T (det)	Frek. Gel. (Hz)	$\lambda$ m	$d/\lambda$	$d/gT^2$	H/D H = 2 cm	H/D H = 4 cm	K $2\pi/\lambda$	K.d
1.2	0.833	2.248	0.846	0.135	0.250	0.500	2.795	5.315
1.3	0.769	2.639	0.721	0.115	0.250	0.500	2.381	4.529
1.4	0.714	3.060	0.622	0.099	0.250	0.500	2.053	3.905
1.5	0.667	3.513	0.541	0.086	0.250	0.500	1.789	3.402
1.6	0.625	3.997	0.476	0.076	0.250	0.500	1.572	2.990
1.7	0.588	4.512	0.422	0.067	0.250	0.500	1.392	2.649
1.8	0.556	5.059	0.376	0.060	0.250	0.500	1.242	2.362
1.9	0.526	5.636	0.337	0.054	0.250	0.500	1.115	2.120
2.0	0.500	6.245	0.305	0.048	0.250	0.500	1.006	1.914

Tabel A.1.2. Validitas Teori Gelombang H = 2 cm

T (det)	$H/(T^2)$	$d/(T^2)$	Teori Gel.
1.2	0.0014	0.1346	linier
1.3	0.0012	0.1147	linier
1.4	0.0010	0.0989	linier
1.5	0.0009	0.0862	linier
1.6	0.0008	0.0757	linier
1.7	0.0007	0.0671	linier
1.8	0.0006	0.0598	linier
1.9	0.0006	0.0537	linier
2.0	0.0005	0.0485	linier

Tabel A.1.3. Validitas Teori Gelombang H = 4 cm

T (det)	$H/(T^2)$	$d/(T^2)$	Teori Gel.
1.2	0.0028	0.1346	linier
1.3	0.0024	0.1147	linier
1.4	0.0021	0.0989	linier
1.5	0.0018	0.0862	linier
1.6	0.0016	0.0757	linier
1.7	0.0014	0.0671	linier
1.8	0.0013	0.0598	linier
1.9	0.0011	0.0537	linier
2.0	0.0010	0.0485	linier



Tinggi Gel 4 cm  
 Periode 1.2 dt

No	Load cell (Volt)	Seasim (Volt)	Trimmer 1 (Volt)	Trimmer 2 (Volt)	No	Load cell (Volt)	Seasim (Volt)	Trimmer 1 (Volt)	Trimmer 2 (Volt)	No	Load cell (Volt)	Seasim (Volt)	Trimmer 1 (Volt)	Trimmer 2 (Volt)	No	Load cell (Volt)	Seasim (Volt)	Trimmer 1 (Volt)	Trimmer 2 (Volt)
1	-0.083	-0.4492	1.1182	0.4004	51	-0.0732	-0.6934	1.1377	-0.0342	101	-0.0537	-0.7471	1.1523	0.1953	151	0.1123	-0.6201	1.2109	-2.0703
2	-0.0781	-0.5859	-10	-3.4033	52	-0.0781	-0.7324	1.1963	0.2637	102	0.0049	-0.7031	1.2305	0.3418	152	0.4785	-0.4736	1.2793	-0.7275
3	-0.0684	-0.708	1.1426	-2.2559	53	-0.0586	-0.7471	-7.3389	-2.334	103	0.1807	-0.625	1.2305	0.3662	153	0.8545	-0.3076	1.2256	-0.2783
4	-0.0635	-0.7422	1.1914	-0.7129	54	-0.0195	-0.7031	1.2305	-1.2695	104	0.6348	-0.4785	0.9717	0.3809	154	0.835	-0.1123	1.2793	-0.2393
5	-0.0293	-0.7617	1.1816	-0.3076	55	0.1563	-0.6348	1.2354	-0.4297	105	1.001	-0.3174	1.2402	0.4102	155	0.6055	0.0781	1.2793	0.3271
6	0.0195	-0.7129	1.2451	0.0635	56	0.5518	-0.4932	-8.5449	-3.0127	106	0.9766	-0.1123	1.3135	0.5615	156	0.1416	0.2734	1.25	0.4883
7	0.2051	-0.6445	0.459	-0.0635	57	0.8936	-0.332	1.25	-1.7285	107	0.6787	0.0732	-0.2002	0.0781	157	-0.0684	0.4297	1.2256	0.0879
8	0.6396	-0.4932	1.2549	0.2295	58	0.8594	-0.127	1.2891	-0.5615	108	0.2148	0.2734	1.2598	0.3662	158	-0.0488	0.5713	1.2305	0.6836
9	0.9717	-0.3271	1.2549	0.3418	59	0.6201	0.0586	-9.7656	-3.5303	109	0.0586	0.4297	1.2256	0.4639	159	-0.0195	0.6543	1.1621	0.6055
10	0.9229	-0.1221	-0.3467	-0.0146	60	0.1514	0.2588	1.2646	-1.9727	110	-0.0488	0.5664	-1.9629	-0.4102	160	-0.0635	0.7178	1.1816	0.6787
11	0.6006	0.0684	1.2451	0.21	61	-0.0293	0.4199	1.2305	-0.7422	111	-0.0537	0.6494	1.1719	-0.1074	161	-0.0684	0.7129	-2.0313	-0.3955
12	0.1465	0.2734	1.4063	0.498	62	-0.0635	0.5615	1.2061	-0.1758	112	-0.0684	0.708	1.1914	0.3174	162	-0.083	0.6836	1.1377	0.0537
13	0.0342	0.4346	-1.3232	-0.2832	63	-0.0293	0.6445	1.1865	-0.0244	113	-0.0684	0.7031	-10	-3.457	163	-0.0781	0.5859	1.1182	0.2637
14	-0.0684	0.5762	1.2109	0.127	64	-0.0732	0.708	0.5811	-0.7422	114	-0.0928	0.6738	1.1475	-1.9727	164	-0.0732	0.4688	-3.335	-0.9766
15	-0.0732	0.6592	1.1768	0.3711	65	-0.0684	0.7031	1.1279	0.2734	115	-0.083	0.5762	1.1084	-0.7373	165	-0.0732	0.2979	1.0791	-0.4639
16	-0.0684	0.7227	-9.6094	-2.8076	66	-0.083	0.6738	1.1475	0.459	116	-0.083	0.4639	-10	-4.2139	166	-0.083	0.1172	1.1133	0.0586
17	-0.0732	0.7178	1.1328	-1.6943	67	-0.083	0.5811	-1.4404	-0.3711	117	-0.0781	0.293	1.0742	-2.6514	167	-0.0781	-0.0879	-5.1514	-1.792
18	-0.0732	0.6885	1.1475	-0.459	68	-0.0928	0.4639	1.1035	0.0537	118	-0.083	0.1172	1.1035	-1.0303	168	-0.0781	-0.2686	1.1084	-0.8887
19	-0.0732	0.5908	-2.7588	-1.4453	69	-0.083	0.2979	1.0889	0.2051	119	-0.083	-0.0879	1.0645	-0.5322	169	-0.0781	-0.4492	1.1084	-0.293
20	-0.0781	0.4785	1.0986	-0.9863	70	-0.0879	0.1221	-2.7246	-0.8545	120	-0.0879	-0.2686	1.1328	-0.6152	170	-0.0781	-0.5859	-6.0107	-2.1875
21	-0.083	0.3076	1.0791	-0.1318	71	-0.0781	-0.083	1.0742	-0.3809	121	-0.083	-0.4492	1.1035	0.1172	171	-0.0732	-0.6934	1.1377	-1.377
22	-0.083	0.1318	1.084	0.1367	72	-0.083	-0.2588	1.1475	0.0537	122	-0.0732	-0.5811	1.1377	0.2588	172	-0.0684	-0.7324	1.2061	-0.4102
23	-0.0781	-0.0781	1.084	-0.332	73	-0.0879	-0.4395	-3.0029	-1.1426	123	-0.0635	-0.6934	1.1426	0.2637	173	-0.0537	-0.7471	1.1768	-0.1367
24	-0.083	-0.2588	1.1182	0.4346	74	-0.0879	-0.5713	1.1475	-0.5029	124	-0.0537	-0.7324	-0.5176	-0.1709	174	0.0195	-0.7031	1.2549	-0.3564
25	-0.0781	-0.4492	1.0889	0.3613	75	-0.0684	-0.6885	1.1523	-0.0781	125	-0.0342	-0.7422	1.1816	0.0391	175	0.2832	-0.6299	1.2451	0.3467
26	-0.0732	-0.5859	1.1475	-0.1709	76	-0.0586	-0.7275	-9.8242	-3.2227	126	0.0439	-0.6982	1.2598	0.3027	176	0.7881	-0.4834	1.25	0.4688
27	-0.0732	-0.708	0.8203	0.3955	77	-0.0342	-0.7422	1.1914	-2.0215	127	0.3906	-0.6201	-2.1094	-0.7031	177	1.123	-0.3174	1.2598	0.459
28	-0.0537	-0.7373	1.1816	0.459	78	0.0391	-0.6982	1.2549	-0.6738	128	1.0254	-0.4785	1.2695	-0.1221	178	1.1719	-0.1172	1.2891	0.5566
29	-0.0439	-0.7568	1.2061	0.4492	79	0.3516	-0.6299	1.2109	-0.2637	129	1.3818	-0.3125	1.2598	0.1611	179	0.8154	0.0781	1.2451	0.5322
30	0	-0.708	-2.9053	-0.7715	80	0.8447	-0.4834	1.3086	-0.2832	130	1.3623	-0.1123	-4.6924	-1.4453	180	0.376	0.2783	1.2744	0.6396
31	0.2051	-0.6396	1.2158	-0.2783	81	1.1426	-0.3223	1.2598	0.3223	131	0.9326	0.083	1.25	-0.7178	181	0	0.4395	1.1084	0.5469
32	0.625	-0.498	1.2695	0.166	82	1.1572	-0.127	1.2695	0.4688	132	0.4736	0.2783	1.2891	-0.0195	182	-0.0146	0.5811	1.2158	0.6348
33	0.9473	-0.3369	-3.4424	-1.167	83	0.752	0.0635	1.2549	-0.0586	133	-0.0244	0.4346	-6.875	-2.2949	183	-0.0586	0.6689	1.2354	0.625
34	0.8643	-0.1367	1.2695	-0.415	84	0.3369	0.2588	1.2744	0.7031	134	0.0439	0.5713	1.2256	-1.1914	184	-0.083	0.7275	-4.4141	-1.0596
35	0.5518	0.0537	1.2646	0.0586	85	-0.0146	0.4199	1.2109	0.625	135	-0.1416	0.6543	1.1816	-0.332	185	-0.0732	0.7275	1.1328	-0.5518
36	0.0879	0.2588	-4.707	-1.5039	86	0.0098	0.5615	1.2305	0.6885	136	-0.1221	0.7129	1.167	0.083	186	-0.0781	0.6934	1.1475	0.0928
37	0.0049	0.415	1.2158	-0.7324	87	-0.0635	0.6494	-0.21	0.1807	137	-0.1025	0.7129	1.1377	0.2344	187	-0.0684	0.5957	-8.6426	-2.7881
38	-0.127	0.5664	1.2256	-0.0439	88	-0.0732	0.7129	1.1719	0.3906	138	-0.1025	0.6787	0.9863	0.3418	188	-0.0781	0.4736	1.1133	-1.5283
39	-0.1123	0.6543	-8.3984	-2.9004	89	-0.0537	0.7129	1.1377	0.498	139	-0.0977	0.5859	1.084	0.3613	189	-0.083	0.293	1.1035	-0.5811
40	-0.0977	0.7227	1.1768	-1.8359	90	-0.083	0.6836	-5.21	-1.3965	140	-0.0928	0.4639	1.1133	0.4736	190	-0.083	0.1123	-10	-3.7402
41	-0.0781	0.7178	1.1279	-0.498	91	-0.0879	0.5908	1.0889	-0.6982	141	-0.0879	0.293	0.0342	0.0781	191	-0.0684	-0.0928	1.0791	-2.29
42	-0.0732	0.6885	1.123	-0.0439	92	-0.0781	0.4688	1.1328	-0.0146	142	-0.0928	0.1172	1.0938	0.2783	192	-0.0732	-0.2783	1.1182	-0.9229
43	-0.0684	0.5957	1.0889	-0.5078	93	-0.083	0.2979	-7.0605	-2.3877	143	-0.0977	-0.0928	1.0938	0.3125	193	-0.0684	-0.459	-10	-4.3506
44	-0.083	0.4834	1.0742	0.4346	94	-0.083	0.1221	1.0938	-1.3281	144	-0.0928	-0.2734	-1.5723	-0.4492	194	-0.0732	-0.5908	1.1475	-2.627
45	-0.0879	0.3076	1.0596	0.3906	95	-0.0879	-0.0879	1.0791	-0.498	145	-0.0879	-0.4541	1.084	-0.1367	195	-0.0635	-0.6982	1.1426	-1.1719
46	-0.0879	0.1367	1.0986	0.4688	96	-0.0879	-0.2686	-9.79	-3.4717	146	-0.0879	-0.5859	1.1523	0.1563	196	-0.0586	-0.7373	1.1768	-0.5176
47	-0.083	-0.0732	-0.4004	-0.0781	97	-0.083	-0.4492	1.2012	-2.0801	147	-0.0879	-0.6982	-3.3887	-1.2061	197	-0.0488	-0.752	1.1865	-0.1953
48	-0.083	-0.2539	0.9766	0.1367	98	-0.0635	-0.5811	1.1572	-0.8398	148	-0.0879	-0.7373	1.1865	-0.6104	198	0.0195	-0.708	-0.0342	-0.3027
49	-0.0879	-0.4395	1.1084	0.2148	99	-0.0635	-0.6934	1.1182	-0.415	149	-0.0635	-0.7471	1.1914	-0.1123	199	0.1709	-0.6299	1.2109	-0.0342
50	-0.0781	-0.5762	-0.7031	-0.249	100	-0.0684	-0.7324	1.1914	-0.625	150	-0.0244	-0.6982	-10	-3.4424	200	0.6689	-0.4834	1.2695	0.2588



Waktu 20 detik  
 Tinggi Gel 4 cm  
 Periode 1.3 dt

No	Load cell (Volt)	Seasim (Volt)	Trimmeter 1 (Volt)	Trimmeter 2 (Volt)	No	Load cell (Volt)	Seasim (Volt)	Trimmeter 1 (Volt)	Trimmeter 2 (Volt)	No	Load cell (Volt)	Seasim (Volt)	Trimmeter 1 (Volt)	Trimmeter 2 (Volt)	No	Load cell (Volt)	Seasim (Volt)	Trimmeter 1 (Volt)	Trimmeter 2 (Volt)
1	-0.1514	-0.0586	1.2305	0.5078	51	0.3223	-0.3174	1.2598	-0.3809	101	1.8848	-0.5127	0.6055	0.2637	151	2.5977	-0.5811	1.2891	-0.6641
2	-0.2686	0.0879	-10	-3.2471	52	-0.21	-0.1904	1.2549	0.0586	102	0.9473	-0.4248	1.2744	0.3857	152	2.3047	-0.5518	1.3135	0.0781
3	-0.2686	0.2393	1.1719	-2.1289	53	-0.1318	-0.0488	-8.877	-2.832	103	0.127	-0.3076	1.2744	0.4932	153	1.6211	-0.4834	1.2695	0.2295
4	-0.2295	0.3613	0.7959	-0.6836	54	-0.2686	0.0879	1.1963	-1.8213	104	-0.1123	-0.1758	-4.4873	-1.2402	154	0.7617	-0.3955	1.2891	0.4102
5	-0.2393	0.4736	1.123	-0.1758	55	-0.2832	0.2197	1.167	-0.498	105	-0.2197	-0.0391	1.2061	-0.6543	155	0.0244	-0.2832	-0.3809	-0.083
6	-0.2344	0.5469	1.123	0.1074	56	-0.2197	0.332	1.1426	-0.1172	106	-0.2051	0.0928	1.1963	-0.0098	156	-0.1123	-0.1563	1.2598	0.2344
7	-0.2441	0.6006	-2.1191	-0.7178	57	-0.2588	0.4346	1.1377	0.1758	107	-0.2246	0.2197	1.1523	0.1953	157	-0.2148	-0.0244	1.2109	0.3613
8	-0.2393	0.6055	1.0938	-0.2539	58	-0.2539	0.5029	-2.6172	-0.8691	108	-0.2295	0.3271	1.1572	0.3467	158	-0.2197	0.1025	-7.8711	-2.3145
9	-0.2393	0.5908	1.1133	0.1611	59	-0.2539	0.5469	1.1035	-0.3125	109	-0.2441	0.4102	-0.3027	-0.0488	159	-0.2246	0.2197	1.1572	-1.5283
10	-0.2295	0.5322	-4.9854	-1.6064	60	-0.2393	0.5566	1.1084	0.0928	110	-0.2344	0.4736	1.1035	0.2002	160	-0.2246	0.3271	1.1572	-0.3174
11	-0.2344	0.459	1.1084	-0.7813	61	-0.249	0.5469	-5.4834	-1.7725	111	-0.2393	0.5127	1.0938	0.3467	161	-0.2393	0.4053	1.123	-0.0293
12	-0.2295	0.3467	1.1328	-0.1807	62	-0.249	0.498	1.1035	-0.9326	112	-0.2393	0.5225	-3.1445	-0.9082	162	-0.249	0.4688	1.1279	0.2344
13	-0.2441	0.2246	-9.292	-3.1006	63	-0.249	0.4346	1.123	-0.2197	113	-0.249	0.5078	1.0938	-0.376	163	-0.2441	0.498	0.2148	0.0049
14	-0.2148	0.0781	1.1621	-1.9971	64	-0.2344	0.332	-8.5156	-2.9199	114	-0.2344	0.4688	1.1133	0.1074	164	-0.2393	0.5078	1.0938	0.2539
15	-0.2246	-0.0635	1.1865	-0.6006	65	-0.2441	0.2148	1.1377	-1.7676	115	-0.2393	0.4004	-6.0547	-1.9629	165	-0.2441	0.4932	1.1035	0.3369
16	-0.1953	-0.2197	1.2012	-0.1855	66	-0.2393	0.0781	1.167	-0.5859	116	-0.2246	0.3076	1.1182	-1.0498	166	-0.2539	0.4541	-1.543	-0.3906
17	-0.0488	-0.3467	1.2451	0.1318	67	-0.2295	-0.0635	1.1719	-0.1514	117	-0.2393	0.1953	1.1426	-0.2979	167	-0.249	0.3809	1.1084	-0.0586
18	0.9033	-0.4736	-0.4688	-0.2686	68	-0.1904	-0.21	1.2158	0.1172	118	-0.2246	0.0635	1.1426	0.0244	168	-0.2393	0.293	1.1523	0.2686
19	1.8213	-0.5566	1.2744	0.0635	69	-0.0342	-0.3418	-0.8887	-0.376	119	-0.2246	-0.0732	1.1816	0.2051	169	-0.2344	0.1758	-6.2305	-1.9482
20	2.7441	-0.6152	1.3232	0.2783	70	0.7617	-0.4541	1.25	0	120	-0.2002	-0.21	0.7129	0.1758	170	-0.2344	0.0439	1.167	-1.1572
21	3.0566	-0.625	1.2842	0.4102	71	1.6211	-0.5371	1.2939	0.2783	121	-0.0977	-0.3369	1.2256	0.3027	171	-0.2295	-0.0928	1.1914	-0.2637
22	2.8955	-0.6104	1.3037	0.4541	72	2.4121	-0.5859	-8.042	-2.4756	122	0.542	-0.4443	1.2695	0.4443	172	-0.1953	-0.2295	1.2109	0.083
23	2.1582	-0.542	0.4639	0.2539	73	2.6465	-0.5957	1.2988	-1.5771	123	1.5186	-0.5225	-2.334	-0.6396	173	0.0098	-0.3516	1.2402	0.2246
24	1.1572	-0.459	1.2744	0.3516	74	2.4658	-0.5762	1.2988	-0.3662	124	2.1826	-0.5713	1.2939	-0.2393	174	0.7471	-0.4541	1.1963	0.3613
25	0.2881	-0.332	1.2842	0.5176	75	1.8213	-0.5127	1.2793	0	125	2.5244	-0.5811	1.3086	0.1904	175	1.5234	-0.5322	1.2549	0.3906
26	-0.2637	-0.2051	-5.3467	-1.5088	76	0.918	-0.4297	1.2891	0.2393	126	2.3486	-0.5566	1.2793	0.3516	176	2.124	-0.5713	1.3037	0.5371
27	-0.1367	-0.0537	1.2109	-0.8105	77	0.0977	-0.3174	-3.9502	-1.2402	127	1.7041	-0.4932	1.2891	0.4248	177	2.2705	-0.5811	-6.582	-1.9043
28	-0.249	0.0879	1.1914	-0.1025	78	-0.0732	-0.1855	1.2305	-0.5859	128	0.8936	-0.4102	-0.293	0.0098	178	1.9629	-0.5518	1.2988	-1.123
29	-0.2734	0.2246	1.1475	0.1709	79	-0.2148	-0.0488	1.2207	-0.0342	129	0.0879	-0.293	1.2549	0.2246	179	1.3232	-0.4883	1.2842	-0.2051
30	-0.2295	0.3418	1.1475	0.3027	80	-0.2148	0.0879	1.1719	0.1758	130	-0.1953	-0.1709	1.25	0.4199	180	0.5664	-0.3906	1.2695	0.1416
31	-0.2588	0.4443	-0.2734	-0.0391	81	-0.2441	0.2148	1.1621	0.3271	131	-0.2197	-0.0391	-5.1025	-1.499	181	-0.0635	-0.2783	1.25	0.2637
32	-0.2539	0.5127	1.0938	0.1758	82	-0.2393	0.3271	0.2832	0.1221	132	-0.1855	0.0928	1.1914	-0.8691	182	-0.2051	-0.1514	0.5127	0.1855
33	-0.2588	0.5664	1.2158	0.4004	83	-0.2539	0.4248	1.1182	0.293	133	-0.2246	0.2197	1.167	-0.0879	183	-0.2051	-0.0244	1.1914	0.2783
34	-0.2441	0.5762	-5.4248	-1.5967	84	-0.2441	0.4883	1.1133	0.4004	134	-0.2246	0.3271	1.1328	0.1758	184	-0.1953	0.1074	1.2061	0.4785
35	-0.2588	0.5664	1.0693	-0.8887	85	-0.2588	0.5322	-2.5098	-0.6787	135	-0.2441	0.4102	1.1279	0.2979	185	-0.2246	0.2148	-9.917	-2.959
36	-0.2539	0.5176	1.084	-0.166	86	-0.2441	0.542	1.084	-0.2295	136	-0.2441	0.4736	0.083	0.0732	186	-0.2344	0.3174	1.1572	-1.8115
37	-0.249	0.4443	1.0742	0.1074	87	-0.249	0.5322	1.1182	0.1807	137	-0.2393	0.5029	1.0938	0.2295	187	-0.2295	0.4004	1.123	-0.5615
38	-0.2344	0.3418	1.1035	-0.2246	88	-0.2295	0.4834	-6.0791	-1.9189	138	-0.2441	0.5127	1.0986	0.3955	188	-0.249	0.4639	1.1133	-0.0977
39	-0.249	0.2295	1.123	0.4492	89	-0.2441	0.415	1.1035	-1.0205	139	-0.249	0.4932	-2.0605	-0.5811	189	-0.249	0.498	1.0986	-0.5469
40	-0.2295	0.083	1.123	0.4443	90	-0.2393	0.3223	1.1377	-0.2734	140	-0.249	0.4492	1.1084	-0.0977	190	-0.249	0.5127	1.0254	0.4004
41	-0.2344	-0.0537	1.1621	0.5029	91	-0.2441	0.2051	-10	-3.5156	141	-0.2441	0.3809	1.1279	0.1807	191	-0.249	0.498	1.084	0.3906
42	-0.2344	-0.21	-2.3877	-0.6201	92	-0.2246	0.0732	1.1621	-2.2461	142	-0.2393	0.293	-4.5898	-1.4355	192	-0.2441	0.459	1.1328	0.5029
43	-0.1807	-0.3369	1.2109	-0.166	93	-0.2051	-0.0635	1.1719	-0.7471	143	-0.2393	0.1807	1.1377	-0.8105	193	-0.2539	0.3857	-0.3174	0
44	0.0391	-0.4639	1.2598	0.2002	94	-0.1758	-0.2051	1.1963	-0.2588	144	-0.2197	0.0537	1.1768	-0.0928	194	-0.249	0.2881	1.1426	0.2637
45	0.9229	-0.5469	-6.5186	-2.0313	95	-0.0781	-0.3271	1.2402	0.0684	145	-0.2246	-0.083	1.1768	0.1172	195	-0.2295	0.166	1.1475	0.3662
46	1.7139	-0.6104	1.2793	-1.2207	96	0.7129	-0.4443	-1.0303	-0.4639	146	-0.1807	-0.21	1.2207	0.3174	196	-0.2393	0.0391	-8.3691	-2.4609
47	2.29	-0.6201	1.2988	-0.2344	97	1.665	-0.5322	1.2744	-0.0879	147	0	-0.3369	1.2207	0.3516	197	-0.2246	-0.1025	1.1816	-1.5771
48	2.3682	-0.5957	1.2793	0.0586	98	2.4463	-0.5811	1.3135	0.2197	148	0.8301	-0.4443	1.2598	0.4688	198	-0.1416	-0.2295	1.2451	-0.3613
49	1.8604	-0.5322	1.377	0.3174	99	2.7344	-0.5957	1.2744	0.3467	149	1.6748	-0.5225	1.3086	0.5029	199	0.1172	-0.3516	1.2158	-0.0586
50	1.0742	-0.4395	-3.1055	-0.9619	100	2.5488	-0.5762	1.2891	0.4297	150	2.373	-0.5713	-4.1895	-1.1133	200	0.9326	-0.4492	1.2842	0.2344



Tinggi Gel 4 cm  
 Periode 1.4 dt

No	Load cell (Volt)	Seasim (Volt)	Trimmeter 1 (Volt)	Trimmeter 2 (Volt)	No	Load cell (Volt)	Seasim (Volt)	Trimmeter 1 (Volt)	Trimmeter 2 (Volt)	No	Load cell (Volt)	Seasim (Volt)	Trimmeter 1 (Volt)	Trimmeter 2 (Volt)	No	Load cell (Volt)	Seasim (Volt)	Trimmeter 1 (Volt)	Trimmeter 2 (Volt)
1	-0.376	0.791	1.123	0.4346	51	-0.376	0.5469	1.0742	0.1172	101	-0.3906	-0.5225	1.1768	0.1611	151	1.4206	-0.8447	1.2988	0.498
2	-0.3662	0.6934	1.1279	0.5029	52	-0.3662	0.6885	-2.71	-0.9082	102	-0.3857	-0.3467	1.1768	0.2979	152	1.4941	-0.8838	-9.4775	-2.7441
3	-0.3467	0.5566	1.2012	0.5713	53	-0.3809	0.7959	1.0791	-0.4297	103	-0.3711	-0.166	-2.6563	-0.8301	153	1.2012	-0.8789	1.2842	-1.8652
4	-0.3027	0.3857	-2.8369	-0.6543	54	-0.3711	0.8643	1.0986	0.0781	104	-0.3857	0.0244	1.1328	-0.3906	154	0.3806	-0.8447	1.2695	-0.4688
5	-0.2686	0.1953	1.2354	-0.1904	55	-0.376	0.8838	-10	-3.5986	105	-0.3857	0.2148	1.123	0.0635	155	-0.1221	-0.7617	1.2402	-0.127
6	0.4346	-0.0146	1.2695	0.2344	56	-0.3613	0.8594	1.1133	-2.207	106	-0.376	0.3955	-10	-3.5449	156	-0.3564	-0.6445	1.2451	0.166
7	1.7676	-0.2197	1.2646	0.3857	57	-0.3711	0.7959	1.1377	-0.7324	107	-0.3809	0.5615	1.0938	-2.2705	157	-0.332	-0.498	-5.7422	-1.8799
8	2.9053	-0.415	1.3135	0.4883	58	-0.3613	0.6885	1.1523	-0.2148	108	-0.3809	0.6982	1.1133	-0.7373	158	-0.3613	-0.332	1.1816	-1.2451
9	3.6523	-0.5908	-1.25	-0.2539	59	-0.3564	0.5518	1.2012	0.1416	109	-0.3809	0.8057	1.0791	-0.2588	159	-0.3662	-0.1563	1.1621	-0.2588
10	3.8818	-0.7373	1.3184	-0.0439	60	-0.2783	0.3711	-6.6602	-2.0898	110	-0.376	0.8691	1.0986	0.0928	160	-0.3806	0.0293	1.1328	0.0488
11	3.3398	-0.8398	1.333	0.332	61	0.1416	0.1807	1.2549	-1.1865	111	-0.376	0.8887	-2.6855	-0.9229	161	-0.3806	0.2148	1.1182	0.2148
12	2.3584	-0.8887	1.3037	0.4102	62	1.3623	-0.0342	1.2891	-0.2393	112	-0.3662	0.8643	1.1182	-0.3711	162	-0.3857	0.3857	-3.7939	-1.1768
13	1.0352	-0.8984	1.3184	0.4834	63	2.6807	-0.2393	1.2842	0.0879	113	-0.3711	0.8008	1.1572	0.083	163	-0.3806	0.5518	1.0889	-0.6641
14	-0.0342	-0.8789	-3.8818	-1.0938	64	3.7842	-0.4395	1.3281	0.3223	114	-0.3613	0.6885	1.1523	0.2979	164	-0.3806	0.6836	1.0889	-0.0146
15	-0.3906	-0.8154	1.2305	-0.5859	65	4.3701	-0.6104	-6.084	-1.8408	115	-0.3613	0.5518	1.2012	0.415	165	-0.3857	0.7861	1.0742	0.166
16	-0.2588	-0.708	1.2109	-0.0244	66	4.3506	-0.7568	1.333	-1.1621	116	-0.2686	0.376	0.0195	0.1318	166	-0.376	0.8496	1.0938	-0.2881
17	-0.3418	-0.5518	1.1572	0.1563	67	3.5059	-0.8545	1.3379	-0.1758	117	0.3564	0.1855	1.2549	0.3271	167	-0.3857	0.874	0.5811	0.3662
18	-0.376	-0.3857	1.1426	0.2832	68	2.2412	-0.8984	1.2988	0.0928	118	1.7773	-0.0244	1.2939	0.5127	168	-0.376	0.8496	1.1084	0.4834
19	-0.3809	-0.2002	-2.4707	-0.7813	69	0.8203	-0.9033	1.2988	0.2832	119	3.0518	-0.2344	1.2939	0.5371	169	-0.376	0.791	1.1621	0.5322
20	-0.3711	-0.0146	1.0742	-0.4346	70	-0.1807	-0.8789	-8.6035	-2.6611	120	4.0771	-0.4346	1.3232	0.5908	170	-0.3711	0.6885	-6.9727	-1.9092
21	-0.3955	0.1807	1.0547	0.0488	71	-0.3711	-0.8008	1.2256	-1.7236	121	4.6875	-0.6104	0.4834	0.3174	171	-0.3711	0.5469	1.1865	-1.2451
22	-0.3809	0.3613	1.0156	0.2002	72	-0.249	-0.6787	1.1816	-0.5225	122	4.5068	-0.752	1.333	0.4102	172	-0.3174	0.3711	1.2305	-0.1318
23	-0.3809	0.5322	0.8789	0.2783	73	-0.3857	-0.5273	1.1475	-0.1758	123	3.6572	-0.8496	1.3477	0.4883	173	-0.0244	0.1807	1.2402	0.1367
24	-0.3809	0.6738	-4.3604	-1.3135	74	-0.4004	-0.3564	1.1377	0.0977	124	2.3877	-0.8887	1.2939	0.5127	174	1.1621	-0.0293	1.2744	0.3711
25	-0.4004	0.7861	1.001	-0.7568	75	-0.4004	-0.1709	-6.9238	-2.2705	125	0.8496	-0.8887	1.2939	0.5029	175	2.5928	-0.2393	-4.4678	-1.3232
26	-0.3809	0.8496	1.0156	-0.0684	76	-0.3955	0.0195	1.0596	-1.5625	126	-0.1563	-0.8545	-0.7178	-0.1025	176	3.7939	-0.4395	1.3232	-0.7666
27	-0.3857	0.8789	1.0107	0.1563	77	-0.3809	0.21	0.8057	-0.4834	127	-0.249	-0.7715	1.2207	0.0635	177	4.4336	-0.6104	1.3477	0.0098
28	-0.3711	0.8545	1.0352	0.3125	78	-0.3955	0.3906	1.0059	-0.1367	128	-0.376	-0.6543	1.1914	0.2881	178	4.4336	-0.7471	1.3184	0.2588
29	-0.3906	0.7959	-5.5225	-1.6455	79	-0.3906	0.5566	1.0107	0.1123	129	-0.3906	-0.5078	1.1475	0.3223	179	3.7598	-0.8398	1.3428	0.3662
30	-0.376	0.6885	1.0742	-0.9668	80	-0.3955	0.6982	-5.5957	-1.792	130	-0.376	-0.3369	1.123	-0.2246	180	2.583	-0.8789	-7.2168	-2.1484
31	-0.3906	0.5518	1.1133	-0.1563	81	-0.4053	0.8057	0.9814	-1.04	131	-0.3955	-0.1611	-0.0391	0.1465	181	1.0254	-0.874	1.2891	-1.4941
32	-0.376	0.376	1.1084	0.1074	82	-0.4004	0.874	0.9912	-0.2441	132	-0.3955	0.0244	1.0449	0.1807	182	-0.0146	-0.8398	1.2744	-0.2881
33	-0.3955	0.1807	1.1621	0.2783	83	-0.3906	0.8936	0.8398	-0.0293	133	-0.4004	0.2148	1.0303	0.3369	183	-0.4443	-0.752	1.2207	-0.0342
34	-0.3516	-0.0244	-2.3584	-0.7178	84	-0.3809	0.8691	1.0059	0.0488	134	-0.3906	0.3906	-10	-3.8477	184	-0.293	-0.6348	1.2061	0.21
35	-0.3613	-0.2295	1.2109	-0.2979	85	-0.3906	0.8057	-1.7139	-0.5322	135	-0.3906	0.5566	0.9912	-2.5391	185	-0.4102	-0.4932	-8.042	-2.5732
36	-0.1367	-0.4248	1.2549	0.1367	86	-0.3906	0.6982	1.0449	-0.249	136	-0.3906	0.6934	0.6787	-0.9473	186	-0.415	-0.3271	1.1279	-1.5869
37	0.5615	-0.6006	1.1133	0.249	87	-0.3906	0.5566	1.084	0.1758	137	-0.3906	0.8008	0.9668	-0.4199	187	-0.3955	-0.1563	1.0938	-0.5469
38	1.123	-0.7471	1.2793	0.2295	88	-0.3662	0.376	-10	-3.6816	138	-0.3906	0.8594	0.9814	-0.0293	188	-0.3955	0.0195	1.0498	-0.1514
39	1.4502	-0.8447	1.0059	0.3613	89	-0.376	0.1807	1.1475	-2.4463	139	-0.3955	0.8838	-3.7256	-1.3232	189	-0.3906	0.2051	1.0645	0.0684
40	1.2451	-0.8936	1.2744	0.4004	90	-0.3613	-0.0244	0.2979	-1.0352	140	-0.3809	0.8594	1.001	-0.7227	190	-0.415	0.3809	-6.9385	-2.2217
41	0.6494	-0.8984	1.2842	0.459	91	-0.3467	-0.2344	1.1865	-0.4736	141	-0.3809	0.8008	1.0205	-0.1123	191	-0.415	0.5371	0.9814	-1.3818
42	0	-0.874	-8.8184	-2.6074	92	-0.2881	-0.4346	1.2354	-0.0098	142	-0.3711	0.6934	1.0303	0.1318	192	-0.415	0.6738	0.9766	-0.4004
43	-0.2588	-0.8057	1.2402	-1.6162	93	-0.0635	-0.6055	-7.2949	-2.4365	143	-0.3906	0.5566	1.0742	0.2637	193	-0.4102	0.7764	0.957	-0.1172
44	-0.3174	-0.6885	1.2256	-0.4736	94	0.5811	-0.752	1.2695	-1.4893	144	-0.3809	0.3809	-1.7871	-0.5322	194	-0.4004	0.8398	0.9961	-0.5029
45	-0.3467	-0.5371	1.1816	-0.1172	95	0.9521	-0.8545	1.2842	-0.4346	145	-0.3711	0.1855	1.123	-0.21	195	-0.4053	0.8643	-0.1367	0.0244
46	-0.3516	-0.3662	1.1768	0.1416	96	1.0156	-0.8984	1.2598	-0.0732	146	-0.3662	-0.0244	1.1621	0.1709	196	-0.4004	0.8447	0.9814	0.2344
47	-0.376	-0.1807	-8.457	-2.6855	97	0.5908	-0.9033	1.3086	0.1611	147	-0.3613	-0.2344	1.1816	0.2734	197	-0.4004	0.7813	1.0205	0.3369
48	-0.3564	0.0098	1.1279	-1.665	98	0.0781	-0.8691	-2.8613	-0.9863	148	-0.293	-0.4346	1.2354	0.3955	198	-0.3857	0.6836	-10	-2.998
49	-0.3809	0.2002	1.1133	-0.5225	99	-0.3662	-0.7959	1.2402	-0.4834	149	0.0879	-0.6104	1.1328	0.3662	199	-0.3906	0.5469	1.0596	-2.0459
50	-0.376	0.3809	1.084	-0.1367	100	-0.2393	-0.6738	1.2305	0.0098	150	0.9277	-0.7471	1.2598	0.4541	200	-0.3906	0.376	1.0693	-0.5664



Waktu 20 detik  
 Tinggi Gel 4 cm  
 Periode 1.5 dt

No	Load cell (Volt)	Seasim (Volt)	Trimmer 1 (Volt)	Trimmer 2 (Volt)	No	Load cell (Volt)	Seasim (Volt)	Trimmer 1 (Volt)	Trimmer 2 (Volt)	No	Load cell (Volt)	Seasim (Volt)	Trimmer 1 (Volt)	Trimmer 2 (Volt)	No	Load cell (Volt)	Seasim (Volt)	Trimmer 1 (Volt)	Trimmer 2 (Volt)
1	-0.1807	0.1367	0.9717	0.3906	51	0.8789	-0.835	1.2695	-1.1572	101	-0.1416	0.7373	1.1768	0.293	151	-0.1758	0.483	-4.585	-1.4111
2	-0.1807	0.3174	0.9766	0.4297	52	-0.0537	-0.8887	1.2598	-0.1318	102	-0.1367	0.6055	-7.7295	-2.334	152	-0.1807	0.2337	0.9961	-0.8936
3	-0.1807	0.4785	-3.6621	-1.0205	53	-0.1611	-0.9131	1.2012	0.0391	103	0.0391	0.4443	1.2354	-1.3574	153	-0.1855	0.443	1.0107	-0.1416
4	-0.1758	0.6104	0.957	-0.542	54	0.0537	-0.8838	1.1963	0.2539	104	1.0352	0.2734	1.2744	-0.2832	154	-0.1807	0.5762	0.9912	0.0439
5	-0.1758	0.7178	0.9863	-0.0049	55	-0.1611	-0.8252	-9.4775	-3.0176	105	2.2217	0.0879	1.2793	0.1074	155	-0.1807	0.708	1.0303	0.2734
6	-0.166	0.8008	-8.4668	-2.8174	56	-0.21	-0.7129	1.1182	-1.9531	106	3.374	-0.0977	1.3232	0.3271	156	-0.1855	0.791	-5.7715	-1.7871
7	-0.166	0.8496	1.0107	-1.3818	57	-0.1855	-0.5957	1.0156	-0.7373	107	3.8672	-0.2832	1.2988	0.4639	157	-0.1758	0.574	1.0498	-1.1426
8	-0.1367	0.8691	-2.5928	-1.7236	58	-0.1807	-0.4297	1.0449	-0.3418	108	3.6572	-0.4541	1.3184	0.4883	158	-0.1709	0.8984	1.0791	-0.1855
9	-0.127	0.8496	1.0547	-1.0156	59	-0.2002	-0.2734	1.0205	-0.0293	109	2.6807	-0.6104	-1.499	-0.3223	159	-0.1758	0.9333	1.0986	0.1465
10	-0.1611	0.7959	1.1084	-0.2051	60	-0.2002	-0.083	-10	-4.0918	110	1.3281	-0.7471	1.2842	-0.1904	160	-0.1709	0.8398	1.1426	0.3125
11	-0.1611	0.708	1.1182	0.0684	61	-0.1953	0.0879	0.9863	-2.749	111	0.3369	-0.8545	1.2842	0.2734	161	-0.1611	0.7368	-6.1279	-1.7773
12	-0.1611	0.5859	1.167	0.3125	62	-0.2002	0.2783	0.4053	-1.167	112	-0.2295	-0.9229	1.2256	0.2979	162	-0.127	0.6201	1.2061	-1.1182
13	-0.1318	0.4395	-2.7393	-0.8203	63	-0.1855	0.4248	0.9619	-0.6006	113	-0.1172	-0.9424	1.2061	0.3906	163	0.0195	0.4888	1.25	-0.083
14	0.0488	0.2783	1.2354	-0.2832	64	-0.2002	0.5811	1.001	-0.1221	114	-0.2246	-0.9277	-4.7607	-1.4844	164	0.9814	0.2881	1.2744	0.1807
15	1.1035	0.0977	1.2793	0.1563	65	-0.1758	0.6885	-6.2842	-2.1973	115	-0.2051	-0.874	1.1328	-0.8984	165	2.0752	0.1025	1.2988	0.4199
16	2.251	-0.0879	1.2842	0.376	66	-0.1807	0.7861	1.0107	-1.3525	116	-0.1611	-0.7764	1.0986	-0.249	166	3.0811	-0.1025	-7.1777	-2.1094
17	3.2422	-0.2783	1.333	0.4639	67	-0.1758	0.8447	1.0254	-0.3857	117	-0.1709	-0.6396	1.0596	0.0049	167	3.3838	-0.2881	1.3135	-0.9033
18	3.4766	-0.4541	-5.4688	-1.5186	68	-0.1514	0.8789	1.04	-0.0146	118	-0.1611	-0.4785	1.0547	0.1123	168	3.1201	-0.4834	0.5566	-0.5664
19	3.0176	-0.6104	1.2988	-1.1035	69	-0.1416	0.8643	1.084	0.21	119	-0.1855	-0.2979	-7.7979	-2.4805	169	2.1729	-0.6396	1.2891	-0.2197
20	1.8066	-0.7373	1.2598	-0.0439	70	-0.1709	0.8203	-7.2119	-2.1875	120	-0.1807	-0.1074	0.9863	-1.6602	170	1.0254	-0.791	1.2939	0.127
21	0.6152	-0.8398	1.2646	0.1172	71	-0.1416	0.7227	1.1377	-1.416	121	-0.1758	0.0879	0.9912	-0.5127	171	0.1904	-0.8984	1.2451	0.2686
22	-0.083	-0.8936	1.2695	0.3418	72	-0.1709	0.6006	1.1768	-0.2588	122	-0.1904	0.2734	0.9668	-0.2148	172	-0.0488	-0.957	1.2354	0.3174
23	0.0928	-0.9082	-9.6729	-3.0029	73	-0.0391	0.4443	1.2012	0.0488	123	-0.1904	0.4395	1.0059	0.0879	173	-0.127	-0.9717	-1.9434	-0.6152
24	-0.1367	-0.8789	1.2793	-1.4307	74	0.166	0.2832	1.2598	0.3369	124	-0.1904	0.5859	-3.0957	-1.1035	174	-0.1416	-0.957	1.1572	-0.4297
25	-0.1807	-0.8105	-0.3662	-1.2207	75	1.3623	0.0977	-6.3232	-1.8945	125	-0.1904	0.708	1.0156	-0.5908	175	-0.1514	-0.8984	1.123	0.0586
26	-0.1465	-0.7031	1.1133	-0.5957	76	2.5439	-0.0928	1.3037	-1.2402	126	-0.1904	0.8008	1.0156	-0.0537	176	-0.1465	-0.8008	1.084	0.1416
27	-0.166	-0.5713	1.0742	-0.1855	77	3.1348	-0.2783	1.2012	-0.1611	127	-0.1855	0.8691	1.0352	0.2148	177	-0.1563	-0.6543	1.0742	0.2344
28	-0.1758	-0.4199	1.0352	0.0439	78	3.2861	-0.4492	1.2646	0.0537	128	-0.1709	0.8984	1.0645	0.3174	178	-0.166	-0.498	-5.2051	-1.6797
29	-0.166	-0.2588	1.0156	0.127	79	2.7197	-0.6104	1.3184	0.2832	129	-0.1709	0.8936	-4.3164	-1.2207	179	-0.1709	-0.3174	1.0156	-1.1719
30	-0.166	-0.0732	-2.2949	-0.7813	80	1.6602	-0.7373	1.2744	0.3857	130	-0.2051	0.8398	1.123	-0.7129	180	-0.1611	-0.127	1.0059	-0.2783
31	-0.1758	0.1123	0.9717	-0.4541	81	0.4688	-0.8447	1.2744	0.4199	131	-0.1563	0.7471	1.1816	0.0537	181	-0.1807	0.0684	0.9961	-0.0293
32	-0.1807	0.293	0.9863	0.083	82	-0.0977	-0.9082	-2.2314	-0.6299	132	-0.1123	0.6152	1.1768	0.2295	182	-0.166	0.2588	1.0107	0.166
33	-0.1758	0.4492	-10	-4.0771	83	-0.0635	-0.9277	1.2061	-0.3906	133	0.0684	0.4639	1.2646	0.4688	183	-0.1709	0.4297	-6.6895	-2.1143
34	-0.1758	0.5908	0.9863	-2.6318	84	-0.1025	-0.9082	1.1768	0.0879	134	1.1865	0.2783	-3.3398	-0.9131	184	-0.1563	0.5762	1.0205	-1.4355
35	-0.1709	0.6982	0.415	-1.1377	85	-0.1465	-0.8496	1.1377	0.1807	135	2.373	0.0977	1.2939	-0.4883	185	-0.166	0.6982	0.7227	-0.4102
36	-0.1611	0.791	1.001	-0.4736	86	-0.166	-0.7471	1.1133	0.2686	136	3.5596	-0.1074	1.3086	0.1758	186	-0.1563	0.7959	1.04	-0.1123
37	-0.1563	0.8447	1.0205	-0.0928	87	-0.166	-0.6152	-4.4141	-1.4209	137	3.916	-0.2881	1.3232	0.4004	187	-0.166	0.8691	1.0693	0.2393
38	-0.1465	0.874	-10	-4.0527	88	-0.1709	-0.459	1.0449	-1.0352	138	3.7793	-0.4736	1.3184	0.4639	188	-0.1416	0.9033	-10	-3.6279
39	-0.1367	0.8594	1.0693	-2.7393	89	-0.1904	-0.2832	1.0254	-0.1953	139	2.8857	-0.6299	1.2939	0.542	189	-0.1563	0.8936	1.1182	-2.2998
40	-0.1172	0.8105	0.498	-1.0303	90	-0.1904	-0.1025	0.9961	0.0146	140	1.4795	-0.7764	1.2793	0.4834	190	-0.1465	0.8447	0.9131	-0.7813
41	-0.1123	0.7129	1.1377	-0.4736	91	-0.1904	0.0879	0.9961	0.1855	141	0.3076	-0.8789	-0.9521	-0.166	191	-0.1563	0.752	1.1719	-0.2979
42	-0.1416	0.5957	1.1963	0.0244	92	-0.1855	0.2686	-6.2305	-1.9678	142	-0.2393	-0.9473	1.2402	-0.0195	192	-0.0879	0.6201	1.2256	0.1172
43	-0.0293	0.4395	1.1816	0.1904	93	-0.1758	0.4297	0.9912	-1.2158	143	-0.0439	-0.957	1.2158	0.2686	193	0.1123	0.4639	-10	-3.1787
44	0.3711	0.2832	1.2695	-0.1172	94	-0.1807	0.5762	0.9961	-0.3271	144	-0.2148	-0.9521	1.1377	0.2539	194	1.1914	0.2881	1.2695	-2.0068
45	1.7578	0.0977	1.04	0.498	95	-0.1709	0.6982	1.001	-0.0146	145	-0.1855	-0.8936	1.1475	0.3516	195	2.251	0.0879	0.9033	-0.6543
46	3.0078	-0.083	1.3086	0.5322	96	-0.1758	0.791	1.0205	0.1953	146	-0.1416	-0.8008	-2.0703	-0.6982	196	3.1885	-0.1123	1.3037	-0.2148
47	3.8135	-0.2686	1.3135	0.5859	97	-0.1709	0.8594	-7.6855	-2.3584	147	-0.1758	-0.6543	1.0742	-0.415	197	3.54	-0.3076	1.3232	0.1465
48	3.8867	-0.4395	1.3135	0.6348	98	-0.1758	0.8936	1.0645	-1.5479	148	-0.1807	-0.498	1.0205	-0.0146	198	3.2227	-0.498	1.2939	0.3271
49	3.3252	-0.6055	1.333	0.5908	99	-0.1611	0.8887	1.1035	-0.332	149	-0.2002	-0.3076	1.0107	0.166	199	2.3242	-0.6641	1.3184	0.4053
50	2.1191	-0.7275	-6.1523	-1.665	100	-0.1514	0.835	1.1182	0.0098	150	-0.1758	-0.1221	1.001	0.2148	200	1.084	-0.8057	-6.2988	-1.8555



Waktu 20 detik  
 Tinggi Gel 4 cm  
 Periode 1.6 dt

No	Load cell (Volt)	Seasim (Volt)	Trimmer 1 (Volt)	Trimmer 2 (Volt)	No	Load cell (Volt)	Seasim (Volt)	Trimmer 1 (Volt)	Trimmer 2 (Volt)	No	Load cell (Volt)	Seasim (Volt)	Trimmer 1 (Volt)	Trimmer 2 (Volt)	No	Load cell (Volt)	Seasim (Volt)	Trimmer 1 (Volt)	Trimmer 2 (Volt)
1	3.4912	0.2832	1.3184	0.5615	51	-0.2686	0.1514	0.9277	-0.5811	101	1.333	-0.4932	1.3086	-1.084	151	-0.2393	0.8105	0.9912	-0.3076
2	3.3447	0.083	1.333	0.6787	52	-0.2588	0.3467	0.9326	-0.249	102	0.1367	-0.6689	1.0254	-0.3467	152	-0.2344	0.9033	1.0303	0.0391
3	2.5635	-0.1318	-5.6934	-1.5137	53	-0.2637	0.542	0.9766	0.0635	103	-0.1367	-0.8154	1.2451	0.0098	153	-0.1904	0.9619	-10	-3.9209
4	1.3281	-0.3369	1.2891	-0.9961	54	-0.2588	0.7031	-8.2178	-2.6465	104	-0.1904	-0.9375	1.1914	0.166	154	-0.1807	0.9863	1.1035	-2.5195
5	0.2539	-0.5273	1.2744	-0.0537	55	-0.2588	0.835	0.9912	-1.6943	105	-0.2051	-1.0107	1.1572	0.2734	155	-0.2002	0.9766	0.6104	-0.9668
6	-0.3027	-0.7031	1.2402	0.1953	56	-0.249	0.9229	0.9766	-0.5273	106	-0.2148	-1.0498	1.123	0.2393	156	-0.1758	0.9326	1.1768	-0.4102
7	-0.1367	-0.8447	1.2158	0.2832	57	-0.21	0.9814	1.04	-0.127	107	-0.21	-1.0498	-1.2109	-0.4346	157	-0.1465	0.8594	1.2354	0.0732
8	-0.2783	-0.9521	-10	-3.4326	58	-0.1709	0.9961	1.0986	0.1855	108	-0.2344	-1.0205	1.0303	-0.4004	158	0.5322	0.752	1.2451	0.3125
9	-0.2686	-1.0254	1.1426	-2.0898	59	-0.2197	0.9863	-8.7012	-2.6514	109	-0.2295	-0.9521	1.0156	0.0684	159	2.124	0.6201	1.2988	0.4834
10	-0.2246	-1.0449	0.1221	-1.1719	60	-0.2002	0.9375	1.167	-1.8311	110	-0.2588	-0.8496	0.9619	0.0781	160	3.7305	0.4639	-1.2451	-0.21
11	-0.2441	-1.0449	1.0693	-0.6982	61	-0.2002	0.8643	0.4736	-0.5518	111	-0.2588	-0.6982	0.9619	0.2002	161	4.9854	0.2881	1.333	0.0391
12	-0.2393	-1.0059	1.0645	-0.2344	62	0.0586	0.752	1.2305	-0.0879	112	-0.2539	-0.5273	-6.7383	-2.207	162	5.5469	0.0977	1.377	0.4395
13	-0.2588	-0.9375	1.0156	-0.0928	63	1.0742	0.625	1.2793	0.2979	113	-0.2588	-0.3223	0.918	-1.6455	163	5.083	-0.1025	1.3281	0.5225
14	-0.2539	-0.8154	1.0156	0.0977	64	2.085	0.459	1.2646	0.4199	114	-0.2588	-0.1123	-1.2695	-1.1328	164	3.9063	-0.3076	1.3477	0.5859
15	-0.2637	-0.6641	-3.6719	-1.333	65	2.998	0.2881	1.3135	0.5615	115	-0.2588	0.1074	0.9082	-0.708	165	1.9775	-0.498	-6.8945	-1.9336
16	-0.2588	-0.4834	0.9863	-0.7959	66	3.2568	0.0879	-2.4121	-0.5664	116	-0.2637	0.3125	0.8984	-0.1758	166	0.3662	-0.6738	1.3086	-1.3037
17	-0.2539	-0.2632	0.9912	-0.2295	67	3.0176	-0.1123	1.3086	-0.3271	117	-0.2588	0.5127	0.9229	0.0781	167	-0.2002	-0.8203	1.25	-0.2393
18	-0.2539	-0.0684	0.9863	0.0195	68	1.9629	-0.3223	1.2988	0.2588	118	-0.2637	0.6836	0.9424	0.2051	168	-0.1904	-0.9424	1.1914	0.0098
19	-0.2588	0.1465	0.9961	0.127	69	0.7568	-0.498	1.2744	0.3857	119	-0.2637	0.8203	-9.7314	-2.9639	169	-0.1807	-1.0205	1.1768	0.1807
20	-0.2588	0.3516	-1.7139	-0.5664	70	-0.1025	-0.6787	1.2695	0.4443	120	-0.2588	0.918	0.9814	-1.9629	170	-0.2295	-1.0547	-10	-3.8379
21	-0.2588	0.542	1.0059	-0.3369	71	-0.0732	-0.8105	-7.6807	-2.251	121	-0.2246	0.9766	0.5566	-0.6934	171	-0.2148	-1.0498	1.084	-2.71
22	-0.2539	0.7129	1.04	0.1563	72	-0.249	-0.9326	1.1914	-1.7041	122	-0.1904	0.9961	1.0449	-0.2979	172	-0.2344	-1.0205	-1.709	-1.8262
23	-0.2441	0.8447	1.04	0.2734	73	-0.249	-1.001	-0.0195	-0.7324	123	-0.1709	0.9912	1.1182	0.1709	173	-0.2393	-0.9521	1.0107	-1.1719
24	-0.2295	0.9473	1.0889	0.4395	74	-0.2148	-1.0449	1.1182	-0.4004	124	-0.2344	0.9521	-10	-3.2861	174	-0.2539	-0.835	1.001	-0.4785
25	-0.2441	1.001	-3.9209	-1.0693	75	-0.2295	-1.0352	1.0986	-0.0098	125	-0.1953	0.8789	1.1865	-1.5283	175	-0.2295	-0.8885	0.9424	-0.2441
26	-0.2539	1.0156	1.1475	-0.5957	76	-0.2344	-1.0156	1.0303	0.0391	126	-0.127	0.7715	0.415	-0.9375	176	-0.2539	-0.5078	0.9229	-0.0293
27	-0.2344	1.001	1.1816	0.1367	77	-0.2588	-0.9326	1.0254	0.166	127	0.542	0.6396	1.2549	-0.2686	177	-0.2441	-0.3076	-8.1006	-2.7246
28	-0.1953	0.9473	1.2061	0.376	78	-0.249	-0.835	-2.7344	-1.0156	128	2.0752	0.4736	1.2939	0.0928	178	-0.2539	-0.0879	0.9082	-2.0361
29	0.1514	0.8643	1.2842	0.542	79	-0.2539	-0.6738	0.9717	-0.6055	129	3.2227	0.2979	1.3037	0.3613	179	-0.2539	0.1221	-1.9336	-1.4795
30	1.3818	0.752	-5.3174	-1.377	80	-0.2539	-0.5029	0.9473	-0.1611	130	4.0527	0.1025	1.3379	0.459	180	-0.2637	0.332	0.9082	-0.9619
31	2.7441	0.6104	1.2988	-0.8936	81	-0.249	-0.293	0.9277	0.0439	131	4.0088	-0.0928	-4.3457	-1.167	181	-0.2539	0.5127	0.918	-0.2734
32	3.8184	0.4492	1.3135	0.1367	82	-0.2539	-0.0977	1.0107	0.1514	132	3.1738	-0.2979	1.3037	-0.835	182	-0.2539	0.6787	0.9326	0.0098
33	4.2969	0.2686	1.3135	0.3174	83	-0.249	0.127	-8.6865	-2.7051	133	1.6602	-0.4883	1.2939	0.083	183	-0.2539	0.8008	0.9766	0.1807
34	4.0918	0.0732	1.3477	0.5029	84	-0.2539	0.3174	0.9375	-1.9482	134	0.4639	-0.6641	1.3037	0.21	184	-0.2539	0.9033	-6.377	-1.9629
35	3.1104	-0.1318	1.2939	0.542	85	-0.2588	0.5127	0.2002	-0.7568	135	-0.2051	-0.8154	1.2549	0.3906	185	-0.2295	0.9521	1.0352	-1.377
36	1.6064	-0.332	1.3525	0.6006	86	-0.2441	0.6738	0.9619	-0.3369	136	-0.1758	-0.9424	-10	-3.291	186	-0.1563	0.9814	1.0547	-0.2148
37	0.4053	-0.5225	-4.7559	-1.2793	87	-0.2441	0.8154	1.0156	0.0781	137	-0.2881	-1.0254	1.1768	-1.6455	187	-0.1563	0.9619	1.0938	0.0635
38	-0.2783	-0.6836	1.25	-0.7568	88	-0.2246	0.9033	-10	-3.2813	138	-0.2197	-1.0547	-1.0449	-1.5723	188	-0.1758	0.9229	1.167	0.3467
39	-0.2246	-0.8252	1.2158	-0.0732	89	-0.1807	0.9717	1.0596	-2.2119	139	-0.2393	-1.0547	1.1035	-0.8887	189	-0.1904	0.8398	-9.6289	-2.876
40	-0.3125	-0.9375	1.167	0.1025	90	-0.1611	0.9863	0.4004	-0.835	140	-0.2295	-1.0303	1.0693	-0.3955	190	0.0732	0.7373	1.25	-1.7236
41	-0.2051	-1.0107	1.1475	0.2246	91	-0.1855	0.9863	1.1328	-0.2441	141	-0.2441	-0.9668	1.0303	-0.1367	191	1.6406	0.5908	1.2793	-0.415
42	-0.249	-1.04	-7.666	-2.4512	92	-0.21	0.9424	1.1719	0.083	142	-0.249	-0.8594	1.0205	0	192	3.1543	0.4443	1.3037	0.0439
43	-0.2734	-1.04	1.0645	-1.7773	93	-0.1855	0.8789	1.2061	0.3516	143	-0.249	-0.7129	-4.0088	-1.4404	193	4.6729	0.2588	1.3477	0.293
44	-0.2588	-1.0059	-0.1807	-0.9277	94	0.3125	0.7617	1.3379	0.4736	144	-0.2637	-0.5322	0.957	-0.9961	194	5.5469	0.083	1.3281	0.4883
45	-0.2686	-0.9326	1.0059	-0.5322	95	1.4746	0.6348	0.3223	0.3125	145	-0.249	-0.3271	0.9375	-0.2734	195	5.4199	-0.1221	1.3525	0.5176
46	-0.2588	-0.8154	0.9863	-0.1318	96	3.0469	0.4688	1.2891	0.3174	146	-0.249	-0.1074	0.9375	-0.0781	196	4.6045	-0.3125	-0.7715	-0.0586
47	-0.2686	-0.6592	-10	-4.1797	97	4.0771	0.293	1.3477	0.6299	147	-0.2539	0.1123	0.9717	0.1416	197	2.7441	-0.5078	1.3086	-0.0439
48	-0.2588	-0.4785	0.9375	-2.8516	98	4.5068	0.0928	1.3135	0.6104	148	-0.2588	0.3223	-10	-3.2861	198	0.9521	-0.6689	1.3037	0.4004
49	-0.2588	-0.2734	-3.1494	-2.3438	99	4.2383	-0.1025	1.3574	0.7031	149	-0.2686	0.5127	0.957	-2.1875	199	-0.1221	-0.8252	1.2451	0.3809
50	-0.2539	-0.0635	0.9375	-1.5674	100	3.0176	-0.3076	-7.1875	-1.9727	150	-0.2539	0.6787	0.6738	-0.8105	200	-0.0977	-0.9326	1.2402	0.4639



Tinggi Gel 4 cm  
 Periode 1.7 dt

No	Load cell (Volt)	Seasim (Volt)	Trimmer 1 (Volt)	Trimmer 2 (Volt)	No	Load cell (Volt)	Seasim (Volt)	Trimmer 1 (Volt)	Trimmer 2 (Volt)	No	Load cell (Volt)	Seasim (Volt)	Trimmer 1 (Volt)	Trimmer 2 (Volt)	No	Load cell (Volt)	Seasim (Volt)	Trimmer 1 (Volt)	Trimmer 2 (Volt)
1	-0.2393	1.0938	-2.5146	-0.6006	51	-0.293	-1.0596	1.0156	-0.1855	101	-0.1855	0.9961	1.167	0.332	151	-0.2539	-0.918	-0.9277	-1.2646
2	-0.1611	1.0693	1.2305	-0.2148	52	-0.2881	-1.0791	0.9668	0.0195	102	-0.1953	1.0645	-8.2373	-2.4658	152	-0.2441	-1.0107	1.1084	-0.8154
3	0.9082	1.0254	1.2891	0.3857	53	-0.2979	-1.0645	0.9326	0.1123	103	-0.1074	1.0938	1.25	-1.4697	153	-0.2637	-1.0645	1.0645	-0.2588
4	2.8369	0.9229	1.2891	0.5225	54	-0.2832	-1.0303	0.8936	0.0977	104	1.0986	1.0791	1.2646	-0.249	154	-0.2637	-1.0791	1.001	-0.1367
5	4.4434	0.8154	1.3428	0.7275	55	-0.2881	-0.9424	-8.1885	-2.6416	105	3.1006	1.0254	1.3037	0.1465	155	-0.2637	-1.0645	1.001	0.0586
6	5.7471	0.6543	-5.9619	-1.6016	56	-0.2881	-0.8252	0.8545	-1.9629	106	4.9609	0.9326	1.3428	0.4346	156	-0.2686	-1.0156	-8.1494	-2.749
7	5.9473	0.4883	1.3574	-0.5127	57	-0.2979	-0.6641	-0.21	-0.9912	107	6.333	0.8057	1.3525	0.6348	157	-0.2734	-0.918	0.9424	-2.0752
8	5.4785	0.2881	0.9619	-0.1709	58	-0.2979	-0.498	0.8447	-0.6396	108	6.9141	0.6543	1.3623	0.6641	158	-0.2783	-0.7861	-2.5879	-1.7578
9	4.0479	0.0928	1.333	0.1025	59	-0.2979	-0.3076	0.874	-0.1465	109	6.1914	0.4834	-0.9277	0.0488	159	-0.2881	-0.625	0.9229	-1.2549
10	2.0166	-0.127	1.3135	0.3516	60	-0.2979	-0.1172	-10	-4.2529	110	4.8096	0.293	1.3428	0.127	160	-0.2881	-0.4492	0.4541	-0.5762
11	0.542	-0.3174	1.2744	0.4785	61	-0.3027	0.083	0.8936	-2.207	111	2.8076	0.1025	1.3428	0.5322	161	-0.2832	-0.2686	0.9131	-0.3613
12	-0.2295	-0.5176	1.2598	0.4785	62	-0.2979	0.2734	-5.0488	-3.0713	112	0.9668	-0.0977	1.2695	0.5127	162	-0.2734	-0.0879	0.9131	-0.0391
13	-0.1758	-0.6787	-8.0322	-2.3242	63	-0.2979	0.459	0.9375	-2.0508	113	-0.0098	-0.293	1.2793	0.6104	163	-0.2734	0.1074	0.9375	0.1367
14	-0.2979	-0.835	1.1621	-1.4795	64	-0.293	0.6201	0.8301	-0.8105	114	-0.2051	-0.4785	-10	-3.0908	164	-0.2783	0.293	0.9521	0.21
15	-0.2783	-0.9424	-0.3174	-0.9131	65	-0.2539	0.7666	1.0107	-0.293	115	-0.2441	-0.6445	1.1816	-1.499	165	-0.2783	0.4688	-6.6357	-2.0313
16	-0.2637	-1.0352	1.0791	-0.5811	66	-0.2295	0.8838	1.0303	0.0293	116	-0.2295	-0.8008	-1.8066	-1.709	166	-0.2588	0.6299	1.0156	-1.4648
17	-0.2686	-1.0693	1.0596	-0.1221	67	-0.1514	0.9814	1.0693	0.2734	117	-0.249	-0.9229	1.084	-1.0547	167	-0.2441	0.7764	0.0391	-0.5615
18	-0.2686	-1.0889	1.001	-0.0439	68	-0.2002	1.04	1.123	0.3613	118	-0.2441	-1.0156	1.0352	-0.4443	168	-0.1855	0.8984	1.0693	-0.2197
19	-0.3027	-1.0645	1.001	0.1172	69	-0.2441	1.0742	-2.3193	-0.5518	119	-0.2637	-1.0693	0.9961	-0.1563	169	-0.2246	0.9912	1.1377	0.249
20	-0.2783	-1.0303	-7.3193	-2.4561	70	-0.2148	1.0645	1.2109	-0.2246	120	-0.293	-1.0938	0.9961	-0.0342	170	-0.2295	1.0498	1.1377	0.3613
21	-0.2832	-0.9375	0.9424	-1.8896	71	0.7959	1.0205	1.2451	0.3467	121	-0.2881	-1.084	-10	-4.165	171	-0.249	1.0742	1.2109	0.5469
22	-0.2832	-0.8203	-2.2803	-1.5674	72	2.876	0.9326	1.2793	0.4785	122	-0.2783	-1.0449	0.8887	-2.2998	172	0.0439	1.0498	-2.251	-0.4932
23	-0.293	-0.6592	0.918	-1.1133	73	4.6191	0.8203	1.377	0.708	123	-0.2783	-0.957	-4.458	-2.9297	173	1.3623	0.9912	1.2793	-0.1514
24	-0.2832	-0.4932	0.6445	-0.4492	74	6.1279	0.6641	-7.9492	-2.124	124	-0.2881	-0.8252	0.8594	-1.9873	174	2.8076	0.8936	1.3135	0.4004
25	-0.2783	-0.2979	0.918	-0.2539	75	6.5234	0.5029	1.3818	-1.2598	125	-0.2979	-0.6592	0.8594	-0.8691	175	4.2578	0.7666	1.3184	0.6006
26	-0.2832	-0.1074	0.9229	0.0098	76	5.9668	0.3125	1.3574	-0.1172	126	-0.2979	-0.4785	0.8545	-0.5127	176	5.0439	0.6152	1.3525	0.6299
27	-0.2881	0.0977	0.9424	0.1758	77	4.5215	0.1221	1.3672	0.2393	127	-0.293	-0.293	0.8691	-0.1611	177	4.8975	0.4541	1.3281	0.7178
28	-0.293	0.2881	0.957	0.2344	78	2.5195	-0.0879	1.3184	0.3467	128	-0.2783	-0.1025	-10	-3.6523	178	3.9844	0.2734	1.333	0.8885
29	-0.2783	0.4785	-5.918	-1.7822	79	0.8105	-0.2832	1.2842	0.4736	129	-0.2832	0.0928	0.9033	-2.1777	179	2.4707	0.0879	-3.9014	-0.8789
30	-0.2637	0.6348	1.0156	-1.3184	80	-0.1563	-0.4785	1.2451	0.459	130	-0.2881	0.2832	-4.1357	-2.5244	180	1.0596	-0.1025	1.2891	-0.6787
31	-0.2246	0.7861	0.4297	-0.3516	81	-0.2539	-0.6445	-4.8828	-1.377	131	-0.2881	0.459	0.9521	-1.582	181	0.0146	-0.2881	1.2793	0.1953
32	-0.1855	0.8887	1.084	-0.0488	82	-0.1514	-0.8008	1.1621	-1.1279	132	-0.2637	0.625	0.9766	-0.5908	182	-0.3174	-0.4688	1.2207	0.2734
33	-0.2393	0.9863	1.1572	0.332	83	-0.249	-0.9131	1.0352	-0.1465	133	-0.2637	0.7715	1.0156	-0.1465	183	-0.127	-0.6299	1.2109	0.415
34	-0.2148	1.0303	1.1523	0.4199	84	-0.2979	-1.0107	1.0742	-0.0684	134	-0.2148	0.8936	1.0498	0.1025	184	-0.2832	-0.7813	1.1377	0.3564
35	-0.1807	1.0596	1.2402	0.6055	85	-0.2881	-1.0645	1.0645	0.1807	135	-0.166	0.9912	-10	-3.2275	185	-0.3027	-0.9082	1.167	0.4053
36	0.9326	1.04	-1.3574	-0.1758	86	-0.2637	-1.0889	0.9961	0.1367	136	-0.2539	1.0547	1.1328	-2.1826	186	-0.2734	-1.001	-3.1592	-1.0059
37	3.1152	0.9961	1.3086	0.0488	87	-0.2783	-1.0742	0.9961	0.2197	137	-0.2197	1.084	-0.7617	-1.1084	187	-0.2734	-1.0596	1.0547	-0.8008
38	5.0439	0.9082	1.3428	0.5469	88	-0.2881	-1.0449	-4.8096	-1.6357	138	-0.2051	1.0693	1.2109	-0.5078	188	-0.2734	-1.0742	0.9814	-0.1416
39	6.6992	0.8008	1.3574	0.7129	89	-0.2832	-0.957	0.9473	-1.2549	139	0.4443	1.0107	1.2793	0.1123	189	-0.3076	-1.0596	0.9766	0.0098
40	7.3242	0.6543	1.377	0.7471	90	-0.2881	-0.835	-0.5811	-0.8105	140	1.8994	0.918	1.2695	0.3223	190	-0.2783	-1.0107	0.9424	0.0879
41	6.8457	0.4932	-4.8828	-1.0938	91	-0.293	-0.6689	0.9229	-0.5615	141	3.6133	0.7861	1.3428	0.5684	191	-0.2832	-0.9082	0.9082	0.1416
42	5.5469	0.3027	1.3477	-0.6787	92	-0.2979	-0.498	0.9033	-0.1318	142	4.624	0.6348	-7.6318	-2.124	192	-0.2979	-0.7764	0.9131	0.1416
43	3.623	0.1123	1.3477	0.1953	93	-0.293	-0.3076	0.9277	0.0293	143	4.9121	0.4688	1.3477	-0.8398	193	-0.293	-0.6152	-8.96	-2.8418
44	1.46	-0.0977	1.2842	0.2539	94	-0.2783	-0.1172	0.9326	0.1611	144	4.292	0.2881	0.6445	-0.4736	194	-0.293	-0.4443	0.8984	-2.1729
45	0.0244	-0.2979	1.2891	0.4688	95	-0.2832	0.083	-10	-3.9404	145	2.998	0.0977	1.3232	-0.1367	195	-0.2881	-0.2588	-3.6182	-2.0215
46	-0.2979	-0.498	1.2061	0.4248	96	-0.2832	0.2734	0.9717	-2.7295	146	1.46	-0.0977	1.2988	0.2295	196	-0.2881	-0.0781	0.9082	-1.499
47	-0.1758	-0.6641	1.1963	0.4834	97	-0.2686	0.459	-1.7139	-1.7236	147	0.3125	-0.2881	1.2744	0.3906	197	-0.293	0.1074	0.2441	-0.6396
48	-0.2979	-0.8154	-5.4443	-1.6406	98	-0.249	0.625	1.0205	-1.1182	148	-0.1807	-0.4785	1.2549	0.4199	198	-0.2881	0.2881	0.9375	-0.3564
49	-0.2881	-0.9277	1.1035	-1.123	99	-0.1904	0.7715	1.0791	-0.2393	149	-0.1318	-0.6445	-8.8037	-2.6074	199	-0.2881	0.459	0.9863	0.0879
50	-0.2734	-1.0156	0.7373	-0.4053	100	-0.2148	0.8936	1.084	0.0195	150	-0.2393	-0.791	1.1621	-1.333	200	-0.2734	0.6104	-10	-4.0527



Tinggi Gel  
Periode

4 cm  
1.8 dt

No	Load cell (Volt)	Seasim (Volt)	Trimmer 1 (Volt)	Trimmer 2 (Volt)	No	Load cell (Volt)	Seasim (Volt)	Trimmer 1 (Volt)	Trimmer 2 (Volt)	No	Load cell (Volt)	Seasim (Volt)	Trimmer 1 (Volt)	Trimmer 2 (Volt)	No	Load cell (Volt)	Seasim (Volt)	Trimmer 1 (Volt)	Trimmer 2 (Volt)
1	-0.3809	-0.9717	1.0986	0.415	51	-0.3857	0.4346	1.1523	-1.4746	101	-0.3516	0.2979	1.2158	-1.5039	151	-0.3955	-0.9326	1.0986	0.1855
2	-0.3906	-1.0303	-2.5732	-0.7422	52	-0.3809	0.6006	-2.8076	-1.8555	102	-0.3564	0.1221	-2.4121	-1.8164	152	-0.3955	-0.8057	1.0645	0.1807
3	-0.3711	-1.084	1.084	-0.5713	53	-0.3809	0.7422	1.1816	-1.2012	103	-0.3613	-0.0684	1.1816	-1.2256	153	-0.3906	-0.6494	1.1084	0.2979
4	-0.3809	-1.084	1.084	0.0049	54	-0.3662	0.8643	1.2207	-0.1514	104	-0.3662	-0.2588	0.9863	-0.3418	154	-0.3809	-0.4688	-1.8311	-0.6348
5	-0.376	-1.0693	1.0742	0.083	55	-0.3418	0.9521	1.2158	0.1611	105	-0.376	-0.4395	1.1523	-0.1221	155	-0.3857	-0.2734	1.1182	-0.293
6	-0.376	-1.0059	1.1035	0.2393	56	-0.3027	1.0156	1.2451	0.4395	106	-0.3809	-0.6104	1.1426	0.1123	156	-0.3857	-0.0781	1.1133	0.0879
7	-0.3711	-0.9277	-8.9014	-2.8369	57	-0.083	1.04	-2.3193	-0.6787	107	-0.376	-0.7568	1.1133	0.2197	157	-0.3955	0.127	1.123	0.2881
8	-0.3809	-0.8008	1.0938	-1.9141	58	0.1611	1.0352	1.2549	-0.0635	108	-0.376	-0.8789	1.1084	0.2344	158	-0.3857	0.3174	1.1328	0.3564
9	-0.3613	-0.6787	0.8594	-0.6982	59	0.3076	0.9961	0.2783	-0.0488	109	-0.3711	-0.9717	-3.0762	-1.0156	159	-0.376	0.498	-6.958	-2.0068
10	-0.3711	-0.5078	1.1719	-0.2441	60	0.1221	0.9326	1.25	0.2051	110	-0.3809	-1.0352	1.084	-0.752	160	-0.3662	0.6592	1.1621	-1.123
11	-0.376	-0.3418	1.1182	0.0391	61	-0.0684	0.835	1.2695	0.459	111	-0.3906	-1.0742	1.0889	-0.1123	161	-0.3662	0.8057	-1.0938	-0.8936
12	-0.376	-0.1416	-10	-3.5791	62	-0.2539	0.7227	1.2305	0.5469	112	-0.3857	-1.084	1.0742	-0.0049	162	-0.3662	0.9131	1.1963	-0.4688
13	-0.3662	0.0439	1.123	-2.4316	63	-0.3027	0.5957	1.2451	0.6006	113	-0.3809	-1.0547	1.1035	0.1709	163	-0.2588	1.0059	1.2549	0.2002
14	-0.3711	0.2393	-0.7861	-1.3232	64	-0.332	0.4541	-2.0898	-0.415	114	-0.3906	-1.001	-9.6484	-3.125	164	-0.0146	1.0596	1.2256	0.3662
15	-0.4004	0.4053	1.1426	-0.8057	65	-0.332	0.293	1.2109	-0.2393	115	-0.3857	-0.9082	1.1035	-2.1533	165	0.5176	1.0889	1.2842	0.5859
16	-0.3955	0.5859	1.1719	-0.0684	66	-0.3564	0.1221	1.1963	0.2881	116	-0.3906	-0.7813	0.3369	-0.9717	166	0.9326	1.0693	-5.4736	-1.4502
17	-0.3711	0.7178	1.1719	0.1563	67	-0.3516	-0.0684	1.1768	0.3223	117	-0.3809	-0.6348	1.1035	-0.4639	167	1.0449	1.0352	1.2842	-0.8594
18	-0.3711	0.8496	1.2109	0.3906	68	-0.3662	-0.2539	1.1719	0.4199	118	-0.3809	-0.4688	1.1133	-0.083	168	0.7227	0.9668	1.2549	0.083
19	-0.3564	0.9277	1.1963	0.4736	69	-0.3613	-0.4443	1.1475	0.4248	119	-0.3809	-0.2832	-10	-3.8916	169	0.3613	0.8789	1.2695	0.3662
20	-0.3174	1.001	1.2354	0.6104	70	-0.3809	-0.6152	1.1572	0.4395	120	-0.3857	-0.0879	1.1133	-2.1533	170	-0.1221	0.7568	1.2549	0.4541
21	-0.1465	1.0205	-1.499	-0.21	71	-0.3662	-0.7715	-6.5479	-1.9482	121	-0.3857	0.1074	-0.6445	-1.5234	171	-0.2979	0.625	1.2451	0.5811
22	0.0684	1.0254	1.25	0.083	72	-0.376	-0.8984	1.1084	-1.3525	122	-0.3857	0.293	1.1279	-0.8984	172	-0.2393	0.4639	1.2207	0.5566
23	0.2051	0.9863	1.2646	0.4492	73	-0.3613	-0.9961	1.0986	-0.3711	123	-0.3809	0.4736	1.167	-0.1807	173	-0.3369	0.3027	-1.4453	-0.2148
24	0.0244	0.9326	1.2402	0.5859	74	-0.376	-1.0645	1.0791	-0.1367	124	-0.4053	0.6299	1.1426	0.0732	174	-0.332	0.1123	1.1816	-0.21
25	-0.1563	0.8398	1.25	0.6299	75	-0.3711	-1.0938	1.0938	0.0781	125	-0.3955	0.7715	1.2012	0.3662	175	-0.3516	-0.0732	1.2061	0.3516
26	-0.2295	0.7422	-3.4717	-0.7715	76	-0.3809	-1.0938	-10	-4.043	126	-0.3809	0.8838	1.1816	0.4346	176	-0.3613	-0.2783	1.1426	0.2734
27	-0.3271	0.6104	1.2256	-0.4297	77	-0.3711	-1.0645	1.0938	-2.1338	127	-0.332	0.9717	1.2793	0.5957	177	-0.3662	-0.459	1.1621	0.4297
28	-0.3271	0.4785	1.2354	0.2393	78	-0.3809	-1.0059	-1.1426	-1.8701	128	-0.2295	1.0254	-1.5283	-0.249	178	-0.3711	-0.6396	1.0986	0.3516
29	-0.3369	0.3125	1.2158	0.3564	79	-0.3906	-0.9131	1.0986	-1.1035	129	0.0439	1.0547	1.2598	0.0732	179	-0.3857	-0.7813	1.1279	0.4053
30	-0.3564	0.1465	1.2061	0.5029	80	-0.3857	-0.791	1.1035	-0.459	130	0.4199	1.0449	1.2646	0.4297	180	-0.3711	-0.9131	-3.6914	-1.1621
31	-0.3516	-0.0488	1.1621	0.4785	81	-0.3711	-0.6445	1.084	-0.1514	131	0.498	1.0107	1.2598	0.6006	181	-0.376	-1.001	1.0889	-0.8398
32	-0.3662	-0.2295	1.1719	0.5225	82	-0.3857	-0.4834	1.1084	0.0391	132	0.3467	0.9424	1.2598	0.6348	182	-0.376	-1.0791	0.9912	-0.1953
33	-0.3662	-0.4199	-7.9004	-2.3145	83	-0.376	-0.3027	-2.3584	-0.8936	133	0.0098	0.8545	-4.6045	-1.084	183	-0.3857	-1.0986	1.0596	-0.0732
34	-0.3711	-0.5859	1.1377	-1.6455	84	-0.3857	-0.1074	1.1182	-0.5273	134	-0.2637	0.7422	1.2354	-0.6543	184	-0.3857	-1.1084	1.0449	0.0781
35	-0.3662	-0.7471	0.5908	-0.5859	85	-0.3711	0.0879	1.1328	0.0342	135	-0.2393	0.6104	1.2549	0.166	185	-0.3857	-1.0742	1.0596	0.1904
36	-0.376	-0.8691	1.1084	-0.2441	86	-0.3857	0.2832	1.123	0.2002	136	-0.3613	0.459	1.2061	0.3027	186	-0.3857	-1.0205	1.0547	0.2051
37	-0.3613	-0.9863	1.1084	0.0293	87	-0.3906	0.4688	1.1914	0.3955	137	-0.3467	0.293	1.2305	0.4883	187	-0.3906	-0.9082	-10	-3.916
38	-0.376	-1.0547	0.9473	0.0928	88	-0.3809	0.6299	-10	-3.3594	138	-0.3516	0.1172	1.1719	0.459	188	-0.3857	-0.7861	1.0596	-2.0996
39	-0.376	-1.1035	1.084	0.1465	89	-0.376	0.7715	1.1865	-1.582	139	-0.3662	-0.0781	1.1914	0.5273	189	-0.3955	-0.6201	-2.8857	-2.2998
40	-0.3857	-1.1035	-2.8174	-1.0059	90	-0.3613	0.8887	-3.3203	-2.0752	140	-0.3711	-0.2686	-6.1279	-1.7773	190	-0.3857	-0.4492	1.0596	-1.499
41	-0.376	-1.084	1.0742	-0.7178	91	-0.3271	0.9717	1.2207	-1.1816	141	-0.376	-0.4541	1.1475	-1.2842	191	-0.3809	-0.2441	1.1133	-0.5176
42	-0.3809	-1.0254	1.0889	-0.1074	92	-0.2832	1.0254	1.2402	-0.2295	142	-0.376	-0.6299	0.6543	-0.3955	192	-0.3857	-0.0537	1.0889	-0.21
43	-0.3711	-0.9326	1.0889	0.0342	93	-0.0244	1.0449	1.2402	0.166	143	-0.3857	-0.7764	1.123	-0.1025	193	-0.3906	0.1611	1.1377	0.1221
44	-0.3857	-0.8057	1.1084	0.1855	94	0.2588	1.0303	1.2695	0.3955	144	-0.3662	-0.8984	1.0938	0.0928	194	-0.4004	0.3418	-6.4453	-2.1045
45	-0.3662	-0.6689	-6.2207	-2.0166	95	0.376	0.9863	-6.4063	-1.7969	145	-0.3662	-0.9912	1.084	0.2002	195	-0.3955	0.5273	1.1621	-1.4697
46	-0.376	-0.5029	1.1084	-1.3281	96	0.1758	0.9277	1.25	-1.1328	146	-0.376	-1.0596	1.0693	0.1855	196	-0.3857	0.6787	-0.6396	-0.7813
47	-0.376	-0.3271	1.1133	-0.3516	97	-0.0439	0.8398	1.2549	-0.0439	147	-0.3857	-1.0938	-3.8818	-1.2842	197	-0.3662	0.8252	1.2061	-0.3418
48	-0.3909	-0.1318	1.1035	-0.0342	98	-0.2832	0.7275	1.2354	0.21	148	-0.3857	-1.0986	1.0596	-1.0254	198	-0.3467	0.9277	1.2207	0.1709
49	-0.3711	0.0635	1.1377	0.1855	99	-0.293	0.6006	1.25	0.4443	149	-0.3955	-1.0791	1.0986	-0.1758	199	-0.1807	1.0254	1.2451	0.4395
50	-0.376	0.2539	-9.8047	-3.0371	100	-0.3467	0.459	-10	-3.1592	150	-0.3906	-1.0254	1.0645	-0.0879	200	0.4688	1.0693	1.3379	0.5615



Tinggi Gel  
Periode

4 cm  
1.9 dt

No	Load cell (Volt)	Seasim (Volt)	Trimmmeter 1 (Volt)	Trimmmeter 2 (Volt)	No	Load cell (Volt)	Seasim (Volt)	Trimmmeter 1 (Volt)	Trimmmeter 2 (Volt)	No	Load cell (Volt)	Seasim (Volt)	Trimmmeter 1 (Volt)	Trimmmeter 2 (Volt)	No	Load cell (Volt)	Seasim (Volt)	Trimmmeter 1 (Volt)	Trimmmeter 2 (Volt)
1	-0.3027	-0.8691	-10	-3.1982	51	-0.293	-0.2979	1.1035	0.0635	101	-0.2295	1.0986	1.2354	-0.3076	151	-0.2881	-0.5664	1.0938	0.1074
2	-0.3027	-0.957	1.0791	-1.5967	52	-0.293	-0.1221	1.1914	0.2393	102	-0.2588	1.0596	1.2305	0.1709	152	-0.293	-0.7129	1.0742	0.21
3	-0.3027	-1.0449	-4.9121	-2.7246	53	-0.2979	0.0586	-9.0332	-2.7539	103	-0.2686	1.0205	1.2109	0.415	153	-0.293	-0.8447	1.0596	0.2051
4	-0.3076	-1.0791	1.0742	-1.9385	54	-0.2783	0.2295	1.1377	-1.3574	104	-0.2637	0.918	1.2109	0.5127	154	-0.2979	-0.957	-8.0859	-2.5537
5	-0.2979	-1.1084	-0.5029	-1.1719	55	-0.2734	0.4004	-4.082	-2.1729	105	-0.2832	0.8105	1.1963	0.6055	155	-0.3076	-1.0449	1.0547	-1.3672
6	-0.3125	-1.084	1.084	-0.7568	56	-0.2686	0.5566	1.1768	-1.5674	106	-0.2734	0.6494	1.1914	0.5908	156	-0.3027	-1.0889	-3.1543	-1.9824
7	-0.3027	-1.0645	1.0693	-0.249	57	-0.2783	0.6982	-0.0586	-0.6152	107	-0.2832	0.498	-10	-2.8418	157	-0.2979	-1.1084	1.0596	-1.5039
8	-0.3174	-0.9814	1.0742	-0.0146	58	-0.2588	0.8154	1.2061	-0.293	108	-0.2881	0.3027	1.167	-1.3721	158	-0.293	-1.0889	0.5859	-0.6006
9	-0.3027	-0.9033	1.084	0.1074	59	-0.2246	0.9229	1.2695	0.2686	109	-0.293	0.1318	-5.1074	-2.5049	159	-0.3027	-1.0449	1.0596	-0.4541
10	-0.3125	-0.7666	1.0742	0.2148	60	-0.1807	0.9961	1.2158	0.4004	110	-0.2832	-0.0684	1.1328	-1.748	160	-0.2979	-0.9668	1.0889	-0.0293
11	-0.2979	-0.6396	1.0938	0.2441	61	-0.1855	1.0547	1.2646	0.6006	111	-0.293	-0.2344	0.8838	-0.5762	161	-0.3027	-0.874	1.0596	0.0391
12	-0.3027	-0.4639	-2.8516	-0.8984	62	-0.1611	1.0742	-7.4365	-2.0361	112	-0.2881	-0.415	1.0986	-0.3027	162	-0.3027	-0.752	1.0986	0.2197
13	-0.2881	-0.3125	1.1133	-0.625	63	-0.1953	1.0791	1.25	-1.3525	113	-0.2979	-0.5615	1.0986	0.0146	163	-0.2979	-0.6152	-10	-3.7549
14	-0.3076	-0.1221	1.1328	0.0439	64	-0.2393	1.0449	0.293	-0.3857	114	-0.293	-0.7227	1.0645	0.0879	164	-0.3027	-0.4639	1.1084	-1.9043
15	-0.3027	0.0439	1.1279	0.1758	65	-0.2637	0.9912	1.2256	-0.0586	115	-0.3076	-0.8398	1.1035	0.2197	165	-0.3027	-0.3223	-1.5234	-1.8359
16	-0.3027	0.2344	1.1719	0.3613	66	-0.2734	0.9033	1.2158	0.3076	116	-0.293	-0.9619	-10	-3.916	166	-0.2881	-0.1563	1.1377	-1.0645
17	-0.2832	0.3857	1.1572	0.4199	67	-0.2686	0.791	1.2061	0.4785	117	-0.3125	-1.04	1.0596	-2.0557	167	-0.293	0	1.1328	-0.3662
18	-0.2881	0.5518	1.2109	0.5684	68	-0.2783	0.6494	1.1963	0.5322	118	-0.293	-1.0986	-6.3184	-3.418	168	-0.2979	0.166	1.1523	0.0049
19	-0.2588	0.6885	1.1963	0.5762	69	-0.2832	0.4883	1.2939	0.625	119	-0.3027	-1.1084	1.0645	-2.4707	169	-0.293	0.3174	1.1572	0.1611
20	-0.2344	0.8203	1.2354	0.6641	70	-0.2832	0.3076	1.167	0.5811	120	-0.293	-1.0986	-1.5576	-1.7236	170	-0.2832	0.4736	1.1816	0.3711
21	-0.1367	0.918	-1.7334	-0.249	71	-0.2881	0.127	1.1475	0.5957	121	-0.3125	-1.0498	1.0645	-1.1963	171	-0.2686	0.6104	1.1963	0.4492
22	0.0586	1.0059	1.2402	-0.0049	72	-0.2881	-0.0732	1.1279	0.5127	122	-0.2979	-0.9766	1.0645	-0.4297	172	-0.2783	0.7568	-8.7939	-2.5684
23	0.1465	1.0547	1.2646	0.4639	73	-0.2881	-0.2539	-4.6191	-1.2549	123	-0.3125	-0.874	1.0693	-0.21	173	-0.249	0.8691	1.2109	-1.1865
24	0.0391	1.0938	1.2402	0.6006	74	-0.2881	-0.4346	1.1035	-0.9521	124	-0.293	-0.752	1.0889	0.0146	174	-0.2295	0.9717	-1.7432	-1.2988
25	-0.127	1.0889	1.2549	0.6738	75	-0.2979	-0.5908	1.0938	-0.0928	125	-0.3076	-0.6104	1.0742	0.1318	175	-0.2197	1.0254	1.2109	-0.7373
26	-0.1563	1.0645	-9.0869	-2.4365	76	-0.293	-0.7471	1.0645	-0.0537	126	-0.2979	-0.4639	1.1035	0.2295	176	-0.2344	1.0693	1.2646	0.0635
27	-0.2539	1.0059	1.2305	-1.0596	77	-0.2979	-0.8643	1.0889	0.1855	127	-0.3125	-0.3027	-5.2881	-1.6748	177	-0.249	1.0596	1.2012	0.2588
28	-0.2539	0.9229	-0.9277	-1.0059	78	-0.3027	-0.9766	1.0352	0.1611	128	-0.3125	-0.1367	1.123	-1.1621	178	-0.2588	1.0449	1.2402	0.5176
29	-0.249	0.8057	1.2061	-0.5908	79	-0.3125	-1.0449	1.0791	0.2832	129	-0.3271	0.0342	1.0986	-0.2051	179	-0.2637	0.9912	1.1865	0.5273
30	-0.2686	0.6689	1.2012	0.1074	80	-0.3076	-1.0986	1.04	0.2148	130	-0.3125	0.2002	1.1426	-0.0342	180	-0.2734	0.918	1.2158	0.6396
31	-0.2734	0.498	1.1768	0.1758	81	-0.3027	-1.0986	1.0889	0.2979	131	-0.3174	0.3613	1.1621	0.2734	181	-0.2881	0.791	-7.1777	-1.9629
32	-0.2881	0.3174	1.1719	0.4004	82	-0.2979	-1.0938	-6.167	-1.9971	132	-0.2881	0.5127	1.1719	0.3955	182	-0.2832	0.6641	1.1963	-0.791
33	-0.2686	0.1221	1.1426	0.4395	83	-0.3027	-1.04	1.0889	-1.499	133	-0.2881	0.6543	1.2012	0.5029	183	-0.2832	0.4932	-3.5889	-1.7529
34	-0.293	-0.0732	1.1426	0.498	84	-0.3027	-0.9766	-0.5811	-0.8984	134	-0.2686	0.7861	1.2061	0.5713	184	-0.2881	0.3369	1.1719	-1.2549
35	-0.2881	-0.2734	1.1328	0.4688	85	-0.3027	-0.8691	1.1035	-0.542	135	-0.2637	0.9082	1.2256	0.6299	185	-0.293	0.1514	-0.4004	-0.6641
36	-0.3076	-0.459	1.1133	0.4395	86	-0.3027	-0.7617	1.0791	-0.1172	136	-0.2246	0.9961	-5.459	-1.3623	186	-0.293	-0.0146	1.1426	-0.3613
37	-0.293	-0.625	-3.623	-1.0547	87	-0.3076	-0.6104	1.1035	0.1074	137	-0.2148	1.0596	1.2305	-0.874	187	-0.2881	-0.21	1.1279	0.0488
38	-0.3076	-0.7715	1.0693	-0.8594	88	-0.3076	-0.4688	1.1279	0.2051	138	-0.2148	1.0938	1.2305	0.1221	188	-0.2979	-0.3613	1.1133	0.21
39	-0.293	-0.8984	0.6104	-0.2197	89	-0.2979	-0.3027	-8.3691	-2.5879	139	-0.2393	1.0938	1.2207	0.2979	189	-0.293	-0.5371	1.1182	0.2539
40	-0.3125	-1.001	1.0547	-0.2002	90	-0.2881	-0.1416	1.1133	-1.9141	140	-0.2588	1.0596	1.2451	0.5176	190	-0.2979	-0.6738	-10	-3.1152
41	-0.3027	-1.0693	1.0596	0.1123	91	-0.2881	0.0342	-0.8545	-1.0303	141	-0.2734	1.0059	1.2012	0.5615	191	-0.293	-0.8203	1.0742	-1.6455
42	-0.3076	-1.1084	1.0547	0.1367	92	-0.2881	0.1904	1.1377	-0.7324	142	-0.2734	0.9131	1.2354	0.6641	192	-0.3027	-0.918	-3.1689	-2.1582
43	-0.293	-1.1133	1.084	0.2588	93	-0.293	0.3613	1.1719	0.0488	143	-0.2783	0.7959	-10	-2.9932	193	-0.2979	-1.0156	1.0645	-1.5625
44	-0.3027	-1.0938	1.0498	0.2393	94	-0.2783	0.5029	1.167	0.0928	144	-0.2832	0.6543	1.1963	-1.3623	194	-0.3027	-1.0596	1.0107	-0.5469
45	-0.293	-1.0498	1.0791	0.2881	95	-0.2783	0.6592	1.2402	0.4492	145	-0.2881	0.4834	-6.2744	-2.8809	195	-0.2979	-1.0889	1.0742	-0.3418
46	-0.3027	-0.9717	-8.2715	-2.6074	96	-0.2734	0.7764	1.1963	0.4834	146	-0.2881	0.3076	1.167	-1.4014	196	-0.3076	-1.0596	1.0889	-0.0293
47	-0.2979	-0.874	1.084	-1.9629	97	-0.2393	0.9033	1.25	0.6494	147	-0.293	0.1221	-2.2754	-1.748	197	-0.293	-1.0303	1.0693	0.0488
48	-0.3125	-0.752	-1.2012	-1.2402	98	-0.2051	0.9814	-9.2627	-2.5684	148	-0.293	-0.0586	1.1426	-1.1133	198	-0.3027	-0.9473	1.0938	0.1807
49	-0.2979	-0.6152	1.0938	-0.7471	99	-0.1904	1.0547	1.25	-1.0742	149	-0.293	-0.2344	1.1182	-0.3223	199	-0.2979	-0.8643	-7.5928	-2.4658
50	-0.3027	-0.459	1.1084	-0.1904	100	-0.1953	1.0791	-0.1807	-0.8301	150	-0.2881	-0.4053	1.1084	-0.0293	200	-0.3027	-0.7373	1.0938	-1.7529



Tinggi Gel 4 cm  
Periode 2.0 dt

No	Load cell (Volt)	Seasim (Volt)	Trimmetter 1 (Volt)	Trimmetter 2 (Volt)	No	Load cell (Volt)	Seasim (Volt)	Trimmetter 1 (Volt)	Trimmetter 2 (Volt)	No	Load cell (Volt)	Seasim (Volt)	Trimmetter 1 (Volt)	Trimmetter 2 (Volt)	No	Load cell (Volt)	Seasim (Volt)	Trimmetter 1 (Volt)	Trimmetter 2 (Volt)
1	-0.2295	-0.8496	1.0791	0.4004	51	-0.1611	0.8691	1.2158	0.6299	101	-0.21	0.7471	1.1768	0.6592	151	-0.2246	-0.8398	1.0693	0.2344
2	-0.2295	-0.6934	1.0986	0.4248	52	-0.1611	0.9961	-6.5137	-1.6553	102	-0.2246	0.6104	1.1475	0.6494	152	-0.2344	-0.9619	1.0742	0.2441
3	-0.2344	-0.5322	1.1084	0.4199	53	-0.1807	1.0693	1.2256	-1.2207	103	-0.2246	0.4492	1.1816	0.6201	153	-0.2246	-1.0596	1.0938	0.2832
4	-0.2295	-0.3516	1.1426	0.4785	54	-0.1709	1.1328	-0.4443	-0.4395	104	-0.2344	0.2881	-10	-2.9199	154	-0.2393	-1.1279	-10	-3.9746
5	-0.2051	-0.1709	1.1279	0.4443	55	-0.1807	1.1523	1.2354	-0.249	105	-0.2197	0.1123	1.123	-1.4453	155	-0.2344	-1.1621	1.084	-2.0996
6	-0.2246	0.0293	-8.0469	-2.29	56	-0.2002	1.1621	1.2158	0.376	106	-0.2197	-0.0488	-2.1436	-1.6699	156	-0.2295	-1.1719	-7.2412	-3.7109
7	-0.2295	0.21	1.1572	-1.0791	57	-0.2051	1.1182	1.1865	0.3662	107	-0.2148	-0.2246	1.0938	-1.1377	157	-0.2148	-1.167	1.0742	-2.0508
8	-0.2246	0.3955	-5.2441	-2.3096	58	-0.2148	1.0742	1.2793	0.6299	108	-0.2344	-0.3809	1.0742	-0.3027	158	-0.2295	-1.1377	-3.1494	-2.4414
9	-0.1953	0.5566	1.1865	-1.6602	59	-0.2197	0.9863	1.1719	0.5762	109	-0.2246	-0.5469	1.0693	-0.2051	159	-0.2295	-1.0791	1.0693	-1.7822
10	-0.1855	0.7227	-0.7129	-0.835	60	-0.2295	0.8887	1.1914	0.6641	110	-0.2295	-0.6885	1.0596	0.0879	160	-0.2393	-0.9766	0.0537	-0.9473
11	-0.166	0.8496	1.2109	-0.4834	61	-0.2148	0.752	1.1572	0.6006	111	-0.2246	-0.835	1.0498	0.1025	161	-0.2246	-0.8496	1.0791	-0.6494
12	-0.1514	0.9717	1.25	0.2148	62	-0.2295	0.625	1.1719	0.6885	112	-0.2295	-0.957	1.0645	0.2148	162	-0.2246	-0.6982	1.084	-0.1514
13	-0.166	1.0498	1.2061	0.3613	63	-0.2295	0.4541	1.1279	0.5908	113	-0.2246	-1.0693	1.0498	0.2002	163	-0.2197	-0.5322	1.0938	0.0391
14	-0.1514	1.1182	1.25	0.6055	64	-0.2246	0.3027	1.1572	0.6396	114	-0.2393	-1.1328	1.0742	0.2734	164	-0.249	-0.3516	1.1377	0.21
15	-0.1855	1.1426	1.1914	0.6006	65	-0.2148	0.127	-9.5313	-2.7344	115	-0.2246	-1.1719	1.0547	0.2393	165	-0.2295	-0.1611	0.9814	0.2539
16	-0.2051	1.1572	1.2305	0.7227	66	-0.2344	-0.0244	1.1133	-1.4453	116	-0.2295	-1.1768	1.0693	0.2832	166	-0.2344	0.0439	1.1475	0.3467
17	-0.2051	1.1182	-8.5596	-2.3096	67	-0.2295	-0.2002	-1.9824	-1.5625	117	-0.2197	-1.1768	-10	-3.6914	167	-0.2393	0.2441	-8.2861	-2.4609
18	-0.2148	1.0693	1.2158	-0.9326	68	-0.2393	-0.3418	1.084	-1.0596	118	-0.2344	-1.1426	1.0645	-1.9287	168	-0.2295	0.4346	1.1816	-1.1377
19	-0.2051	0.9814	-4.9707	-2.207	69	-0.2197	-0.5127	0.8643	-0.3564	119	-0.2295	-1.0889	-7.0313	-3.5547	169	-0.2051	0.6152	-4.6094	-2.1973
20	-0.2197	0.8789	1.2207	-0.9521	70	-0.2295	-0.6494	1.0596	-0.249	120	-0.2246	-0.9814	1.0693	-2.2607	170	-0.1953	0.7764	1.2158	-1.4746
21	-0.2197	0.7422	-2.9785	-1.6504	71	-0.2295	-0.8008	1.0547	0.0488	121	-0.2246	-0.8594	-2.6611	-2.1436	171	-0.166	0.9131	0.791	-0.3613
22	-0.2295	0.6104	1.1768	-1.2061	72	-0.2344	-0.9131	1.0498	0.0928	122	-0.2344	-0.7031	1.0791	-1.4648	172	-0.1416	1.0205	1.2207	-0.0586
23	-0.2246	0.4443	-1.0498	-0.8008	73	-0.2246	-1.0352	1.0645	0.1758	123	-0.2295	-0.542	1.0938	-0.5078	173	-0.1416	1.0938	1.25	0.3369
24	-0.2197	0.293	1.1572	-0.5127	74	-0.2295	-1.0986	1.0596	0.2344	124	-0.2246	-0.3564	1.1035	-0.1904	174	-0.1465	1.1377	1.2207	0.4688
25	-0.2197	0.1172	1.1084	0.0537	75	-0.2197	-1.1523	1.0693	0.249	125	-0.2002	-0.166	1.1377	0.0635	175	-0.1855	1.1572	1.2305	0.6152
26	-0.2344	-0.0439	1.123	0.2148	76	-0.2295	-1.1572	1.0596	0.2783	126	-0.2393	0.0439	1.1328	0.2344	176	-0.1953	1.1475	1.1914	0.6348
27	-0.2246	-0.21	1.1035	0.3125	77	-0.2295	-1.1621	1.0791	0.2637	127	-0.2197	0.2393	1.1719	0.3662	177	-0.1953	1.1133	1.2402	0.6934
28	-0.2295	-0.3613	1.0938	0.376	78	-0.2344	-1.123	-10	-3.8574	128	-0.2246	0.4395	1.1572	0.4541	178	-0.2197	1.0498	-7.7783	-2.0654
29	-0.2295	-0.5225	1.0693	0.332	79	-0.2197	-1.0791	1.0693	-2.0654	129	-0.1953	0.6152	1.3086	0.5566	179	-0.2197	0.9668	1.1963	-0.8398
30	-0.2344	-0.6641	-9.1748	-2.7832	80	-0.2295	-0.9668	-7.7051	-3.7793	130	-0.1807	0.7813	-8.9209	-2.4805	180	-0.2197	0.8594	-5.0195	-2.1582
31	-0.2295	-0.8105	1.0596	-1.4697	81	-0.2344	-0.8545	0.9668	-2.4121	131	-0.1563	0.9229	1.2305	-1.0986	181	-0.2148	0.7275	1.1768	-0.9717
32	-0.2344	-0.9277	-3.7988	-2.2266	82	-0.2393	-0.6934	-2.1533	-2.0508	132	-0.1514	1.0352	-1.4746	-1.1914	182	-0.2295	0.5811	-3.1299	-1.6943
33	-0.2295	-1.04	1.0645	-1.6797	83	-0.2197	-0.5469	1.0938	-1.377	133	-0.1465	1.1133	1.2305	-0.6641	183	-0.2148	0.4297	1.1523	-1.2354
34	-0.2295	-1.1035	0.2393	-0.7715	84	-0.2295	-0.3613	1.1133	-0.4541	134	-0.1514	1.167	1.2354	0.0928	184	-0.2148	0.2637	0.0146	-0.5225
35	-0.2344	-1.1475	1.0645	-0.5859	85	-0.21	-0.1904	1.1182	-0.1563	135	-0.1758	1.1865	1.2158	0.2979	185	-0.2148	0.0977	1.1182	-0.2832
36	-0.2344	-1.1523	1.0986	-0.0879	86	-0.2393	0.0195	1.1621	0.1709	136	-0.2002	1.1865	1.2207	0.4834	186	-0.2295	-0.0732	1.1133	0.0928
37	-0.2295	-1.1572	1.0596	-0.0146	87	-0.2197	0.2002	1.1475	0.2686	137	-0.2002	1.1426	1.2012	0.5566	187	-0.2295	-0.2393	1.0889	0.2148
38	-0.2246	-1.1182	1.1035	0.1807	88	-0.2246	0.4004	1.1914	0.4492	138	-0.21	1.0889	1.2061	0.6543	188	-0.2246	-0.4053	1.0889	0.2783
39	-0.2344	-1.0693	1.0645	0.1611	89	-0.1953	0.5664	1.1768	0.4785	139	-0.2051	1.001	1.1768	0.6494	189	-0.2246	-0.5566	1.0645	0.3076
40	-0.2393	-0.9619	1.0986	0.2783	90	-0.1953	0.7373	1.2402	0.6055	140	-0.2393	0.8984	1.2109	0.6787	190	-0.2295	-0.7031	1.0645	0.2979
41	-0.2295	-0.8447	-6.6602	-2.1387	91	-0.1758	0.874	-7.7734	-2.1387	141	-0.2295	0.7666	-3.7891	-1.0059	191	-0.2295	-0.835	-9.7949	-3.0322
42	-0.2246	-0.6885	1.1182	-1.5137	92	-0.1709	0.9961	1.2305	-0.8643	142	-0.2197	0.625	1.1621	-0.2832	192	-0.2295	-0.9473	1.0645	-1.5967
43	-0.2197	-0.5371	0.3223	-0.6348	93	-0.1563	1.0742	-0.8496	-0.8936	143	-0.2002	0.4639	-8.6719	-2.959	193	-0.2246	-1.04	-5.415	-2.8271
44	-0.2393	-0.3564	1.1328	-0.3076	94	-0.1563	1.1377	1.2109	-0.4541	144	-0.2246	0.2979	1.1377	-1.4502	194	-0.2295	-1.1084	1.0547	-2.1631
45	-0.2246	-0.1807	1.1426	0.0537	95	-0.1904	1.1523	1.2158	0.1758	145	-0.2197	0.127	-2.6758	-1.8604	195	-0.2246	-1.1426	-1.6943	-1.5527
46	-0.2246	0.0244	1.1572	0.2539	96	-0.2002	1.1572	1.2012	0.3564	146	-0.2295	-0.0488	1.1182	-1.2109	196	-0.2344	-1.1572	1.0645	-1.2012
47	-0.2295	0.21	1.1621	0.332	97	-0.2002	1.1182	1.2158	0.5029	147	-0.21	-0.2197	1.0986	-0.3564	197	-0.2393	-1.1475	0.8545	-0.415
48	-0.2246	0.4053	1.1816	0.4736	98	-0.21	0.0693	1.1865	0.5957	148	-0.2295	-0.3857	1.0791	-0.1465	198	-0.2246	-1.1182	1.0596	-0.3467
49	-0.21	0.5713	1.2061	0.5322	99	-0.2051	0.9766	1.1963	0.6445	149	-0.2246	-0.5469	1.0889	0.0732	199	-0.21	-1.0547	1.084	0.0244
50	-0.1904	0.7373	1.2012	0.6299	100	-0.2246	0.8789	1.1621	0.6641	150	-0.2393	-0.6982	1.0547	0.1514	200	-0.2246	-0.9473	1.0645	0.0732



Tinggi Gel 2 cm  
 Periode 1.2 dt

No	Load cell (Volt)	Seasim (Volt)	Trimmetr 1 (Volt)	Trimmetr 2 (Volt)	No	Load cell (Volt)	Seasim (Volt)	Trimmetr 1 (Volt)	Trimmetr 2 (Volt)	No	Load cell (Volt)	Seasim (Volt)	Trimmetr 1 (Volt)	Trimmetr 2 (Volt)	No	Load cell (Volt)	Seasim (Volt)	Trimmetr 1 (Volt)	Trimmetr 2 (Volt)
1	-0.1025	0.0391	-3.1641	-0.8301	51	0.0684	-0.1514	1.2549	0.2148	101	-0.083	-0.3125	1.2598	0.5127	151	-0.1172	-0.4053	1.2451	-1.1816
2	0.0342	-0.0439	1.2549	-0.5908	52	0.0098	-0.2344	1.2549	0.376	102	-0.083	-0.3711	1.2354	0.5518	152	-0.0439	-0.415	-0.1514	-0.4834
3	0.0977	-0.1563	0.8301	0.0684	53	-0.0781	-0.3076	1.25	0.4004	103	-0.1025	-0.4004	1.25	0.5273	153	-0.0732	-0.4004	1.2451	-0.3076
4	0.0146	-0.2344	1.2451	0.1367	54	-0.0977	-0.3613	1.2402	0.498	104	-0.0488	-0.4053	-5.1416	-1.3818	154	-0.1074	-0.3662	1.2549	0.2148
5	-0.0732	-0.3223	1.25	0.3955	55	-0.1025	-0.3906	1.25	0.498	105	-0.0488	-0.3955	1.25	-1.123	155	-0.1807	-0.3027	1.2402	0.3076
6	-0.0977	-0.3662	1.2451	0.4932	56	-0.0488	-0.3955	1.2451	0.5566	106	-0.1074	-0.3564	-0.415	-0.4785	156	-0.2393	-0.2197	1.2549	0.4297
7	-0.0928	-0.4053	1.25	0.4736	57	-0.0586	-0.3857	1.25	0.5127	107	-0.1709	-0.2979	1.2402	-0.3467	157	-0.2588	-0.1221	1.2354	0.4834
8	-0.0537	-0.3955	1.2402	0.5469	58	-0.1074	-0.3467	-4.9756	-1.3281	108	-0.2441	-0.2148	1.2451	0.2441	158	-0.293	-0.0244	1.2549	0.5566
9	-0.0684	-0.3955	1.25	0.5371	59	-0.1807	-0.293	1.2402	-1.1084	109	-0.2637	-0.1221	1.2402	0.293	159	-0.2979	0.0781	1.2305	0.5762
10	-0.1221	-0.3467	-4.3506	-1.25	60	-0.2441	-0.2051	-0.2979	-0.4053	110	-0.2783	-0.0244	1.2598	0.4785	160	-0.2783	0.166	1.2646	0.6055
11	-0.166	-0.293	1.2402	-0.4932	61	-0.2441	-0.1123	1.2305	-0.2979	111	-0.2881	0.0732	1.2305	0.4932	161	-0.293	0.2441	-6.0742	-1.6064
12	-0.2344	-0.1953	-4.6582	-1.8164	62	-0.2783	-0.0146	1.2598	0.2979	112	-0.2832	0.1611	1.2549	0.6006	162	-0.2881	0.2979	1.25	-0.6396
13	-0.2393	-0.1123	1.2402	-1.3623	63	-0.2734	0.083	1.2402	0.3271	113	-0.2881	0.2344	1.2256	0.5859	163	-0.3271	0.332	-1.0596	-0.8301
14	-0.2783	0	-0.0732	-0.5078	64	-0.2734	0.1758	1.2646	0.5225	114	-0.293	0.2832	1.25	0.6445	164	-0.3271	0.3271	1.2451	-0.5273
15	-0.2881	0.0879	1.2354	-0.3418	65	-0.2832	0.2441	1.2256	0.5127	115	-0.3076	0.3125	-6.5479	-1.7578	165	-0.3369	0.3174	1.2451	0.1709
16	-0.2832	0.1904	1.2695	0.2734	66	-0.2832	0.2979	1.2646	0.6445	116	-0.3076	0.3174	1.2451	-0.6885	166	-0.3223	0.2686	1.2305	0.2588
17	-0.2783	0.2539	1.2305	0.3271	67	-0.3027	0.3223	1.2207	0.5957	117	-0.3174	0.2979	-1.4014	-0.9912	167	-0.3223	0.2148	1.2549	0.4688
18	-0.2734	0.3174	1.2646	0.5225	68	-0.3174	0.3271	1.2549	0.6738	118	-0.3223	0.2588	1.2256	-0.6348	168	-0.2637	0.1318	1.2305	0.5078
19	-0.3174	0.3369	1.2207	0.5176	69	-0.332	0.3076	-6.4258	-1.7188	119	-0.3125	0.2002	1.2451	0.0977	169	-0.1514	0.0439	1.2598	0.5908
20	-0.3223	0.3516	1.2646	0.6494	70	-0.3369	0.2686	1.2549	-0.6445	120	-0.2588	0.1172	1.2402	0.2197	170	0.0098	-0.0586	1.333	0.6055
21	-0.3369	0.3271	1.2158	0.5957	71	-0.3076	0.21	-1.3379	-0.9668	121	-0.1221	0.0342	1.2549	0.415	171	0.0635	-0.1465	1.2549	0.6201
22	-0.3174	0.3027	1.2598	0.6738	72	-0.2344	0.127	1.2451	-0.5859	122	0.0195	-0.0684	1.2402	0.4932	172	0.0146	-0.2393	-7.3193	-2.0264
23	-0.3125	0.2246	-6.25	-1.6699	73	-0.1221	0.0391	1.25	0.0928	123	0.0684	-0.1611	1.2598	0.5469	173	-0.1123	-0.3076	1.2549	-0.8838
24	-0.2344	0.1563	1.2598	-0.6201	74	-0.0049	-0.0635	1.25	0.2393	124	0.0195	-0.249	1.2354	0.5615	174	-0.0977	-0.3711	-1.9775	-1.3086
25	-0.127	0.0537	-1.1426	-0.9082	75	0.0537	-0.1611	1.2549	0.3857	125	-0.1025	-0.3223	1.2598	0.5615	175	-0.1123	-0.3955	1.25	-0.8936
26	0.0195	-0.0439	1.2744	-0.5469	76	0.0049	-0.249	1.2451	0.4932	126	-0.0928	-0.3809	-7.8955	-2.2168	176	-0.0537	-0.4053	1.2402	-0.0586
27	0.0879	-0.1465	1.2402	0.0977	77	-0.0781	-0.3271	1.2549	0.5127	127	-0.1123	-0.4053	1.25	-1.0205	177	-0.0732	-0.3809	1.2451	0.0732
28	0.0098	-0.2344	1.2598	0.2441	78	-0.083	-0.3809	1.2402	0.5615	128	-0.0439	-0.4102	-2.4121	-1.499	178	-0.127	-0.3516	1.2549	0.3223
29	-0.0732	-0.3174	1.2451	0.376	79	-0.1123	-0.4102	1.2549	0.5273	129	-0.0781	-0.3955	1.2451	-1.0498	179	-0.1807	-0.2832	1.2451	0.4248
30	-0.0977	-0.3662	1.25	0.4834	80	-0.0586	-0.415	-7.8906	-2.207	130	-0.1172	-0.3613	1.1816	-0.1221	180	-0.2344	-0.2002	1.2598	0.5078
31	-0.0977	-0.4004	1.25	0.498	81	-0.0635	-0.4004	1.2402	-1.04	131	-0.1758	-0.293	1.2402	-0.0195	181	-0.2783	-0.0977	1.2354	0.5469
32	-0.0439	-0.4004	1.2451	0.5615	82	-0.1074	-0.3662	-2.4805	-1.5039	132	-0.2441	-0.21	1.2598	0.3223	182	-0.2881	-0.0049	1.3623	0.6055
33	-0.0684	-0.3955	1.2402	0.5273	83	-0.1758	-0.3076	1.2646	-1.0645	133	-0.2588	-0.1123	1.2354	0.4053	183	-0.3027	0.0977	-8.7207	-2.4121
34	-0.1318	-0.3564	-7.6465	-2.124	84	-0.2393	-0.2197	1.1621	-0.1025	134	-0.2881	-0.0098	1.2549	0.5225	184	-0.2783	0.1807	1.25	-1.0986
35	-0.1807	-0.3027	1.2354	-0.9961	85	-0.2539	-0.127	1.2402	-0.0244	135	-0.2832	0.0879	1.2256	0.5322	185	-0.2881	0.2588	-2.9736	-1.6748
36	-0.2441	-0.2197	-2.2559	-1.3965	86	-0.2783	-0.0244	1.2598	0.3613	136	-0.2734	0.1807	1.2793	0.6055	186	-0.2881	0.3076	1.2402	-1.1475
37	-0.2393	-0.1318	1.2305	-1.001	87	-0.2783	0.0732	1.2305	0.4053	137	-0.2881	0.2539	-9.6094	-2.7002	187	-0.3125	0.3418	0.9326	-0.1953
38	-0.2881	-0.0293	1.2158	-0.0342	88	-0.2783	0.166	1.2646	0.5469	138	-0.293	0.3027	1.2451	-1.2256	188	-0.3369	0.3369	1.2402	-0.0488
39	-0.2979	0.0684	1.2256	0.0293	89	-0.2881	0.2441	1.2256	0.5322	139	-0.3174	0.332	-3.5254	-1.9385	189	-0.3418	0.3223	1.25	0.3516
40	-0.2979	0.166	1.2695	0.4102	90	-0.2979	0.2979	1.2695	0.6396	140	-0.3174	0.3369	1.25	-1.3037	190	-0.3223	0.2783	1.2939	0.4443
41	-0.2881	0.2344	1.2061	0.4199	91	-0.3125	0.3223	-9.8633	-2.7783	141	-0.332	0.3223	0.625	-0.376	191	-0.3174	0.2197	1.25	0.5273
42	-0.2881	0.293	1.2695	0.5957	92	-0.3174	0.332	1.25	-1.2354	142	-0.3174	0.2783	1.2402	-0.166	192	-0.2588	0.1367	1.2305	0.5322
43	-0.3076	0.3174	1.2158	0.5566	93	-0.3271	0.3125	-3.7646	-2.0508	143	-0.3076	0.2197	1.25	0.2734	193	-0.1465	0.0488	1.2598	0.6055
44	-0.3174	0.3271	1.2744	0.6738	94	-0.332	0.2734	1.25	-1.3623	144	-0.2539	0.1367	1.2402	0.3906	194	-0.0049	-0.0586	-10	-2.8857
45	-0.3369	0.3076	-9.7559	-2.7344	95	-0.3223	0.21	0.4346	-0.4883	145	-0.1367	0.0439	1.2549	0.4688	195	0.0635	-0.1465	1.2549	-1.3477
46	-0.3271	0.2734	1.2744	-1.2012	96	-0.2539	0.1367	1.25	-0.2148	146	-0.0049	-0.0537	1.2402	0.5078	196	0.0195	-0.2441	-4.1357	-2.2412
47	-0.3027	0.2051	-3.5791	-1.9873	97	-0.127	0.0488	1.2549	0.2148	147	0.0586	-0.1465	1.2646	0.5615	197	-0.1025	-0.3174	1.2451	-1.5479
48	-0.2295	0.1318	1.2598	-1.3037	98	0.0098	-0.0488	1.2451	0.376	148	0.0098	-0.2441	-0.7617	-0.2002	198	-0.1074	-0.3809	0.2588	-0.6494
49	-0.1221	0.0391	0.5957	-0.4346	99	0.0586	-0.1465	1.2598	0.4199	149	-0.1074	-0.3174	1.25	0.1318	199	-0.127	-0.4004	1.2451	-0.3711
50	0.0049	-0.0537	1.2598	-0.1709	100	0	-0.2344	1.2402	0.498	150	-0.0977	-0.3809	-4.7754	-1.5381	200	-0.0586	-0.4102	1.2646	0.1172



Tinggi Gel 2 cm  
 Periode 1.3 dt

No	Load cell (Volt)	Seasim (Volt)	Trimmeter 1 (Volt)	Trimmeter 2 (Volt)	No	Load cell (Volt)	Seasim (Volt)	Trimmeter 1 (Volt)	Trimmeter 2 (Volt)	No	Load cell (Volt)	Seasim (Volt)	Trimmeter 1 (Volt)	Trimmeter 2 (Volt)	No	Load cell (Volt)	Seasim (Volt)	Trimmeter 1 (Volt)	Trimmeter 2 (Volt)
1	-0.1318	-0.0195	1.2402	0.4443	51	-0.166	-0.127	1.2549	0.5664	101	-0.1074	-0.2051	-2.1826	-1.2354	151	-0.0977	-0.2734	1.2256	0.3369
2	-0.1514	0.0537	1.25	0.5859	52	-0.1709	-0.0635	1.2354	0.6152	102	-0.1221	-0.1611	1.2305	-0.9424	152	-0.1416	-0.2441	1.2695	0.4883
3	-0.1611	0.1123	1.2354	0.625	53	-0.1855	0.0049	1.2402	0.5762	103	-0.1416	-0.0977	0.7666	-0.1074	153	-0.1221	-0.2148	1.2256	0.4639
4	-0.166	0.166	1.2549	0.6006	54	-0.166	0.0635	-6.9629	-1.8652	104	-0.1563	-0.0439	1.2305	-0.0977	154	-0.1416	-0.1514	1.2598	0.5859
5	-0.1367	0.21	1.2305	0.6445	55	-0.2295	0.1221	1.2549	-0.8203	105	-0.1953	0.0244	1.2598	0.3857	155	-0.1758	-0.1074	1.2305	0.5371
6	-0.1074	0.2344	1.25	0.6396	56	-0.2197	0.1758	-2.7979	-1.4307	106	-0.2246	0.0732	1.2207	0.3564	156	-0.2002	-0.0342	1.2793	0.625
7	-0.0391	0.249	1.2354	0.6836	57	-0.1855	0.21	1.2354	-1.0742	107	-0.2148	0.1367	1.2646	0.5469	157	-0.2051	0.0146	-10	-2.9492
8	0.0732	0.2441	1.2451	0.6445	58	-0.1855	0.2393	0.3467	-0.2637	108	-0.21	0.1758	1.2158	0.5225	158	-0.2295	0.0879	1.25	-1.3477
9	0.1953	0.2295	-8.0713	-2.1484	59	-0.1367	0.249	1.2305	-0.1953	109	-0.2002	0.2197	1.2646	0.6543	159	-0.2344	0.1318	-5.3906	-2.6074
10	0.2539	0.1953	1.2451	-0.9717	60	-0.083	0.2539	1.2598	0.3613	110	-0.2051	0.2295	1.2207	0.5957	160	-0.2441	0.1855	1.2402	-1.2256
11	0.1807	0.1465	-3.6963	-1.7822	61	0.0195	0.2295	1.2354	0.3418	111	-0.1367	0.2539	1.2646	0.6836	161	-0.2148	0.21	-1.5137	-1.377
12	0.1074	0.0977	1.2402	-1.3477	62	0.1172	0.21	1.2793	0.5566	112	-0.1221	0.2393	1.0986	0.5811	162	-0.2197	0.2393	1.2402	-0.918
13	0.1025	0.0342	-0.2637	-0.5664	63	0.1465	0.1563	1.2305	0.5273	113	-0.0146	0.2344	1.2842	0.6641	163	-0.166	0.2393	1.0986	-0.0879
14	0.1123	-0.0342	1.2354	-0.4297	64	0.0879	0.1123	1.2744	0.6543	114	0.0879	0.1855	-6.1719	-1.6406	164	-0.127	0.2441	1.2354	0.0244
15	0.166	-0.0977	1.2598	0.2393	65	0.0537	0.0439	1.2256	0.5811	115	0.1123	0.1611	1.2598	-0.625	165	0.0146	0.2197	1.2549	0.3711
16	0.1514	-0.166	1.2354	0.21	66	0.0439	-0.0146	1.2646	0.6641	116	0.1221	0.0977	-2.1143	-1.1816	166	0.1367	0.1953	1.2402	0.4395
17	0.0928	-0.2148	1.2695	0.4785	67	0.0635	-0.0879	1.2256	0.5859	117	0.0293	0.0488	1.25	-0.8154	167	0.1855	1.465	1.2598	0.5176
18	0.0146	-0.2637	1.2207	0.4541	68	0.0684	-0.1416	1.2646	0.6445	118	0.0586	-0.0244	0.8105	-0.0879	168	0.1318	0.0977	1.2402	0.5518
19	-0.0293	-0.2881	1.2744	0.5469	69	0.0684	-0.2051	-6.6943	-1.8408	119	0.0342	-0.083	1.25	-0.0098	169	0.0586	0.0342	1.2598	0.6055
20	-0.0488	-0.3076	1.2207	0.498	70	-0.0098	-0.2393	1.25	-0.7568	120	0.0732	-0.1465	1.2549	0.3613	170	0.0488	-0.0244	1.2354	0.5908
21	-0.0537	-0.2979	1.2695	0.6006	71	-0.0537	-0.2783	-2.5293	-1.4063	121	0.0342	-0.1953	1.2305	0.4004	171	0.0488	-0.0928	1.2744	0.6201
22	-0.0781	-0.2881	1.2158	0.5322	72	-0.1123	-0.2783	1.25	-0.9912	122	0.0146	-0.2441	1.2549	0.4883	172	0.083	-0.1465	-10	-2.9199
23	-0.1025	-0.2393	1.2598	0.6104	73	-0.1025	-0.2881	0.542	-0.2783	123	-0.0244	-0.2686	1.2354	0.5176	173	0.083	-0.2051	1.2549	-1.3672
24	-0.1025	-0.2002	-7.6221	-2.1436	74	-0.1172	-0.2539	1.25	-0.1465	124	-0.0781	-0.2783	1.2598	0.5762	174	0.0049	-0.2441	-5.293	-2.5977
25	-0.1123	-0.1318	1.2598	-0.9033	75	-0.1123	-0.2295	1.2549	0.2832	125	-0.083	-0.2734	1.2256	0.5615	175	-0.0244	-0.2734	1.25	-1.2549
26	-0.1367	-0.0781	-3.2813	-1.7236	76	-0.1367	-0.1709	1.2402	0.3467	126	-0.1123	-0.249	1.3135	0.6104	176	-0.0879	-0.2783	-1.3232	-1.3623
27	-0.1563	0.0049	1.25	-1.2012	77	-0.1416	-0.1221	1.2549	0.4639	127	-0.1123	-0.21	-8.1445	-2.3633	177	-0.0928	-0.2734	1.25	-0.918
28	-0.1611	0.0586	0	-0.5078	78	-0.1709	-0.0586	1.2402	0.5176	128	-0.1123	-0.1611	1.25	-1.0547	178	-0.127	-0.2441	1.2012	-0.1074
29	-0.1855	0.127	1.25	-0.293	79	-0.1953	0	1.25	0.5859	129	-0.1416	-0.1074	-5.874	-2.5781	179	-0.127	-0.2051	1.2402	0.0146
30	-0.1709	0.1709	1.2451	0.2393	80	-0.2197	0.0684	1.2207	0.5908	130	-0.1611	-0.0439	1.25	-1.2256	180	-0.1318	-0.1563	1.2451	0.3076
31	-0.1563	0.2197	1.2402	0.3174	81	-0.2051	0.127	1.25	0.625	131	-0.1807	0.0244	-1.8701	-1.4844	181	-0.1611	-0.0977	1.2451	0.4199
32	-0.1465	0.2344	1.2549	0.4834	82	-0.2246	0.1758	1.2207	0.6152	132	-0.21	0.083	1.2402	-1.001	182	-0.1855	-0.0391	1.25	0.4541
33	-0.0732	0.2539	1.2354	0.5566	83	-0.21	0.21	1.25	0.6396	133	-0.2246	0.1367	0.9326	-0.1855	183	-0.2197	0.0244	1.2354	0.542
34	0.0098	0.2393	1.2549	0.5713	84	-0.21	0.2393	-6.6504	-1.7773	134	-0.2197	0.1855	1.2402	-0.0439	184	-0.2197	0.083	1.2451	0.5518
35	0.083	0.2295	1.2354	0.6055	85	-0.1416	0.2441	1.2402	-0.708	135	-0.2051	0.2197	1.2451	0.3174	185	-0.2393	0.1367	1.2354	0.6152
36	0.1221	0.1855	1.2598	0.6348	86	-0.1025	0.2441	-2.4805	-1.3281	136	-0.2148	0.2441	1.2451	0.4248	186	-0.2344	0.1855	1.2646	0.5957
37	0.0537	0.1514	1.2256	0.6299	87	0.0195	0.2246	1.2549	-0.9082	137	-0.1514	0.249	1.2451	0.4932	187	-0.2148	0.2148	-10	-2.9053
38	0.0537	0.0928	1.25	0.6348	88	0.1318	0.1953	0.6055	-0.1855	138	-0.1172	0.2441	1.2451	0.5811	188	-0.21	0.2344	1.2354	-1.4014
39	0.0244	0.0391	-7.207	-1.9482	89	0.1758	0.1563	1.25	-0.0586	139	-0.0049	0.2246	1.2549	0.5957	189	-0.1709	0.2441	-5.3662	-2.5488
40	0.0928	-0.0293	1.2549	-0.8252	90	0.1367	0.1074	1.25	0.3418	140	0.083	0.2002	1.2451	0.6445	190	-0.127	0.2344	1.2354	-1.2646
41	0.0879	-0.0928	-2.9785	-1.5576	91	0.0488	0.0488	1.2451	0.415	141	0.1221	0.1563	1.2598	0.6104	191	-0.0146	0.2197	-1.3721	-1.2793
42	0.1025	-0.1563	1.2549	-1.1133	92	0.0586	-0.0146	1.1377	0.4541	142	0.1221	0.1025	-10	-2.7734	192	0.127	0.1807	1.2305	-0.9326
43	0.0146	-0.21	0.2441	-0.4004	93	0.0586	-0.0781	1.2451	0.542	143	0.0342	0.0439	1.2451	-1.3281	193	0.1416	0.1416	1.1963	-0.0146
44	-0.0146	-0.2588	1.2402	-0.2441	94	0.0928	-0.1416	1.2598	0.5615	144	0.0391	-0.0195	-5.5859	-2.5928	194	0.1318	0.083	1.2305	-0.0049
45	-0.0439	-0.2832	1.2549	0.2344	95	0.0586	-0.1953	1.2402	0.6055	145	0.0439	-0.0879	1.2402	-1.2939	195	0.0439	0.0293	1.2695	0.4004
46	-0.0586	-0.3027	1.2451	0.3027	96	0.0146	-0.2344	1.25	0.5762	146	0.0732	-0.1416	-1.5332	-1.3721	196	0.0586	-0.0439	1.2256	0.3857
47	-0.0537	-0.293	1.2549	0.4248	97	-0.0098	-0.2637	1.2549	0.6152	147	0.0488	-0.2002	1.2305	-1.0107	197	0.0488	-0.0977	1.2842	0.5273
48	-0.1123	-0.2686	1.2402	0.5078	98	-0.083	-0.2783	1.2451	0.5566	148	-0.0146	-0.2393	1.1328	-0.0977	198	0.0781	-0.166	1.2256	0.4883
49	-0.127	-0.2344	1.25	0.5225	99	-0.083	-0.2686	-6.3965	-1.7236	149	-0.0293	-0.2734	1.2256	-0.0732	199	0.0732	-0.2051	1.2744	0.6006
50	-0.1318	-0.1807	1.2256	0.5762	100	-0.1025	-0.249	1.2402	-0.7715	150	-0.1074	-0.2783	1.2598	0.3418	200	0.0244	-0.2588	1.2256	0.5322



Tinggi Gel 2 cm  
Periode 1.4 dt

No	Load cell (Volt)	Seasim (Volt)	Trimmeter 1 (Volt)	Trimmeter 2 (Volt)	No	Load cell (Volt)	Seasim (Volt)	Trimmeter 1 (Volt)	Trimmeter 2 (Volt)	No	Load cell (Volt)	Seasim (Volt)	Trimmeter 1 (Volt)	Trimmeter 2 (Volt)	No	Load cell (Volt)	Seasim (Volt)	Trimmeter 1 (Volt)	Trimmeter 2 (Volt)
1	0.0977	-0.0439	1.2598	0.5615	51	0.1758	0.415	1.25	-1.0889	101	-0.1709	0.2246	1.2354	0.5029	151	-0.2783	-0.332	-6.543	-2.9834
2	0.0391	-0.1367	1.2402	0.5322	52	0.1318	0.3809	-5.6592	-2.5146	102	-0.0488	0.3076	1.3428	0.5859	152	-0.3223	-0.2441	1.2451	-1.5186
3	0.0488	-0.2344	1.2598	0.5859	53	0.2051	0.3174	1.25	-1.1572	103	0.1465	0.3662	1.2354	0.6396	153	-0.3174	-0.1514	-3.4961	-2.1094
4	0.0195	-0.3125	1.2354	0.5713	54	0.3027	0.2441	-2.3828	-1.5869	104	0.3369	0.4199	1.2598	0.6152	154	-0.3076	-0.0488	1.2305	-1.5967
5	-0.0098	-0.3857	1.2598	0.6201	55	0.3076	0.1514	1.25	-1.123	105	0.3955	0.4395	1.2402	0.6641	155	-0.3027	0.0488	-1.0107	-0.9424
6	-0.0586	-0.4248	1.25	0.5859	56	0.1953	0.0586	0	-0.4785	106	0.2734	0.4395	1.2598	0.6641	156	-0.2588	1.465	1.2354	-0.7227
7	-0.083	-0.4492	1.2598	0.6104	57	0.1025	-0.0537	1.2402	-0.332	107	0.1611	0.4199	1.2354	0.6934	157	-0.1758	0.2344	0.9424	0.0293
8	-0.1025	-0.4541	1.2354	0.5762	58	0.0391	-0.1465	1.25	0.2246	108	0.1318	0.376	1.2744	0.6738	158	-0.0439	0.3174	1.25	0.0146
9	-0.0879	-0.4443	1.2744	0.6006	59	0.0439	-0.2441	1.2451	0.2197	109	0.1904	0.3223	-10	-2.7197	159	0.1611	0.376	1.25	0.459
10	-0.1172	-0.4102	-9.8486	-2.8027	60	0.0293	-0.3223	1.25	0.4395	110	0.3027	0.2441	1.25	-1.2744	160	0.332	0.4199	1.2402	0.4053
11	-0.1807	-0.3662	1.2451	-1.3086	61	-0.0098	-0.3906	1.2354	0.4541	111	0.2881	0.1465	-6.6846	-2.8857	161	0.3906	0.4395	1.2793	0.6006
12	-0.2246	-0.2881	-6.0352	-2.7832	62	-0.0879	-0.4248	1.2549	0.4883	112	0.1807	0.0488	1.25	-1.4404	162	0.2686	0.4395	1.2402	0.5762
13	-0.2246	-0.2002	1.2451	-1.3574	63	-0.1221	-0.4492	1.2354	0.5322	113	0.0781	-0.0537	-3.4082	-2.0264	163	0.1563	0.415	1.2598	0.6396
14	-0.2344	-0.0977	-2.9346	-1.8799	64	-0.166	-0.4492	1.2598	0.5176	114	0.0391	-0.1563	1.2402	-1.5381	164	0.1221	0.376	1.2354	0.6055
15	-0.2051	-0.0049	1.2402	-1.3525	65	-0.1904	-0.4395	1.2305	0.5469	115	0.0293	-0.249	-0.7715	-0.8643	165	0.1758	0.3125	1.2598	0.6934
16	-0.1611	0.0977	-0.4346	-0.6982	66	-0.2344	-0.4004	1.25	0.5518	116	0.0098	-0.332	1.2402	-0.6934	166	0.2783	0.2344	1.2305	0.6299
17	-0.0732	0.1855	1.2451	-0.4834	67	-0.2734	-0.3516	1.2207	0.5713	117	-0.0244	-0.3955	1.1182	0.0537	167	0.2637	0.1318	1.2646	0.6836
18	0.0537	0.2734	1.2305	0.1904	68	-0.2979	-0.2637	1.2842	0.5713	118	-0.1025	-0.4346	1.2402	-0.0098	168	0.1904	0.0391	1.2354	0.6201
19	0.2393	0.332	1.2451	0.2002	69	-0.3027	-0.1758	-9.7656	-2.7686	119	-0.1318	-0.4541	1.25	0.3809	169	0.083	-0.0684	1.2549	0.6494
20	0.3516	0.3857	1.2549	0.498	70	-0.3076	-0.0684	1.25	-1.3184	120	-0.166	-0.4492	1.2354	0.3125	170	0.0293	-0.1611	-8.0371	-2.2363
21	0.332	0.415	1.2402	0.5127	71	-0.293	0.0293	-7.0996	-3.0566	121	-0.2002	-0.4346	1.2549	0.4883	171	0.0195	-0.2637	1.25	-0.9766
22	0.1855	0.4248	1.2598	0.6006	72	-0.2588	0.127	1.2402	-1.5283	122	-0.2393	-0.3955	1.2305	0.4639	172	0.0049	-0.3418	-4.6338	-2.1875
23	0.1367	0.4053	1.2354	0.6348	73	-0.166	0.2148	-3.8867	-2.2168	123	-0.2637	-0.3369	1.2549	0.5273	173	-0.0098	-0.4102	1.2451	-1.0156
24	0.1318	0.376	1.2598	0.6299	74	-0.0488	0.2979	1.2549	-1.6162	124	-0.3027	-0.2539	1.2256	0.498	174	-0.0977	-0.4443	-1.7725	-1.3623
25	0.2539	0.3174	1.2354	0.6494	75	0.1611	0.3564	-1.0791	-0.9619	125	-0.3076	-0.1611	1.25	0.6006	175	-0.1367	-0.4639	1.2354	-0.9766
26	0.2881	0.249	1.2549	0.6641	76	0.3418	0.415	1.2451	-0.7129	126	-0.3125	-0.0635	1.2207	0.5518	176	-0.1855	-0.459	0.459	-0.3271
27	0.2539	0.1563	1.2402	0.6641	77	0.4102	0.4346	0.9668	0.0586	127	-0.2979	0.0391	1.2598	0.6348	177	-0.2002	-0.4395	1.2402	-0.2295
28	0.1367	0.0586	1.2695	0.6543	78	0.2979	0.4395	1.2451	0.0391	128	-0.2637	0.1367	1.2158	0.5859	178	-0.2441	-0.4004	1.2402	0.2344
29	0.083	-0.0488	0.5713	0.293	79	0.1807	0.4199	1.25	0.4688	129	-0.1758	0.2295	1.2402	0.6543	179	-0.2734	-0.3369	1.2354	0.2441
30	0.0391	-0.1416	1.25	0.4199	80	0.127	0.3857	1.2402	0.4102	130	-0.0439	0.3076	-8.623	-2.3877	180	-0.3125	-0.249	1.25	0.4297
31	0.0537	-0.2393	-7.1484	-2.0557	81	0.1855	0.3223	1.2598	0.6006	131	0.1709	0.3711	1.2549	-1.0205	181	-0.3076	-0.1514	1.2256	0.4688
32	0.0439	-0.3174	1.25	-0.9326	82	0.293	0.249	1.2402	0.5713	132	0.3467	0.4199	-5.249	-2.3535	182	-0.3223	-0.0488	1.2451	0.5078
33	-0.0146	-0.3906	-3.9014	-1.8896	83	0.2881	0.1563	1.2598	0.6201	133	0.3857	0.4443	1.2549	-1.0449	183	-0.2979	0.0488	1.2305	0.5664
34	-0.0977	-0.4248	1.2549	-1.4355	84	0.1855	0.0537	1.2402	0.5859	134	0.2734	0.4395	-2.168	-1.4551	184	-0.2734	0.1465	1.25	0.5908
35	-0.1318	-0.4492	-1.1475	-0.9229	85	0.0879	-0.0537	1.2598	0.6543	135	0.1465	0.4199	1.25	-1.001	185	-0.1709	0.2344	1.2256	0.6299
36	-0.1807	-0.4492	1.2402	-0.7275	86	0.0439	-0.1514	1.2256	0.5859	136	0.1123	0.376	0.1563	-0.3662	186	-0.0439	0.3125	1.2598	0.6396
37	-0.1855	-0.4443	0.8838	-0.0244	87	0.0439	-0.249	1.2598	0.6396	137	0.1611	0.3125	1.25	-0.2197	187	0.1758	0.3711	1.2305	0.6689
38	-0.2295	-0.4053	1.2402	-0.0586	88	0.0098	-0.332	1.2256	0.5713	138	0.2783	0.2393	1.25	0.293	188	0.3467	0.4199	1.2646	0.6592
39	-0.2539	-0.3564	1.2451	0.3711	89	-0.0049	-0.3955	1.25	0.6055	139	0.2783	0.1465	1.2451	0.2979	189	0.3906	0.4395	-10	-2.7588
40	-0.2881	-0.2734	1.2451	0.3174	90	-0.1025	-0.4297	-8.2764	-2.3486	140	0.1855	0.0488	1.25	0.4883	190	0.2588	0.4395	1.2549	-1.2695
41	-0.2832	-0.1904	1.2451	0.5127	91	-0.1367	-0.4541	1.2451	-1.0498	141	0.0732	-0.0537	1.2402	0.5127	191	0.1563	0.4102	-6.5869	-2.8467
42	-0.3027	-0.0879	1.2305	0.498	92	-0.1758	-0.4492	-5.0098	-2.3486	142	0.0244	-0.1563	1.2598	0.5273	192	0.1123	0.3711	1.2549	-1.3965
43	-0.2832	0.0098	1.2549	0.5713	93	-0.2051	-0.4346	1.2451	-1.1035	143	0.0146	-0.249	1.2402	0.5713	193	0.1904	0.3027	-3.2861	-1.9482
44	-0.2539	0.1123	1.2256	0.5615	94	-0.249	-0.4004	-2.0605	-1.5039	144	0.0146	-0.3369	1.25	0.5615	194	0.2783	0.2295	1.25	-1.4648
45	-0.1709	0.2002	1.25	0.6543	95	-0.2832	-0.3467	1.2402	-1.0791	145	-0.0098	-0.4004	1.2354	0.5811	195	0.2588	0.1318	-0.7129	-0.791
46	-0.0488	0.2881	1.2305	0.625	96	-0.2979	-0.2637	0.1172	-0.459	146	-0.0977	-0.4346	1.2549	0.5566	196	0.1758	0.0342	1.2451	-0.6152
47	0.1611	0.3516	1.2549	0.6934	97	-0.293	-0.1709	1.2305	-0.3174	147	-0.1367	-0.4541	1.2207	0.5762	197	0.0928	-0.0732	1.123	0.1074
48	0.3516	0.4053	1.2256	0.6543	98	-0.3027	-0.0684	1.2354	0.2246	148	-0.1709	-0.4541	1.333	0.5713	198	0.0342	-0.1709	1.2451	0.0488
49	0.4297	0.4248	1.2549	0.7031	99	-0.2979	0.0342	1.25	0.2344	149	-0.2051	-0.4346	-10	-2.9541	199	0.0098	-0.2686	1.25	0.4199
50	0.2979	0.4346	-9.209	-2.5098	100	-0.2588	0.1318	1.25	0.4688	150	-0.2441	-0.3955	1.2402	-1.4453	200	-0.0049	-0.3467	1.2354	0.3516



Tinggi Gel 2 cm  
 Periode 1.5 dt

No	Load cell (Volt)	Seasim (Volt)	Trimmetter 1 (Volt)	Trimmetter 2 (Volt)	No	Load cell (Volt)	Seasim (Volt)	Trimmetter 1 (Volt)	Trimmetter 2 (Volt)	No	Load cell (Volt)	Seasim (Volt)	Trimmetter 1 (Volt)	Trimmetter 2 (Volt)	No	Load cell (Volt)	Seasim (Volt)	Trimmetter 1 (Volt)	Trimmetter 2 (Volt)
1	-0.21	-0.4004	1.2402	0.4443	51	0.1563	0.3613	1.2354	-1.2207	101	-0.2686	-0.1611	1.2402	0.5615	151	-0.1953	-0.3909	1.2598	0.5615
2	-0.2539	-0.4443	1.2695	0.5811	52	0.1807	0.3369	-0.8008	-0.6494	102	-0.2686	-0.0732	-9.126	-2.5439	152	-0.1855	-0.4443	1.2402	0.5518
3	-0.2441	-0.4736	1.2354	0.5225	53	0.1025	0.2734	1.2402	-0.5713	103	-0.2148	0.0195	1.25	-1.1963	153	-0.1758	-0.4785	1.2549	0.5859
4	-0.2441	-0.4785	1.2549	0.5713	54	0.0195	0.2197	0.5859	0.0439	104	-0.083	0.1123	-6.4893	-2.7832	154	-0.1563	-0.498	1.2305	0.5615
5	-0.2246	-0.4785	1.2451	0.5566	55	-0.0244	0.1318	1.2354	-0.0586	105	0.1172	0.1953	1.2402	-1.3818	155	-0.1953	-0.498	1.2598	0.5811
6	-0.2588	-0.4541	1.2549	0.5615	56	-0.0244	0.0488	1.25	0.459	106	0.2197	0.2637	-4.3018	-2.2363	156	-0.2051	-0.4883	1.2354	0.5566
7	-0.2783	-0.4199	1.2354	0.5469	57	0.0098	-0.0488	1.2354	0.2734	107	0.1855	0.3223	1.2402	-1.0791	157	-0.2441	-0.4541	1.2646	0.5762
8	-0.3125	-0.3564	1.2646	0.6104	58	0.0195	-0.1318	1.2646	0.5713	108	0.0684	0.3711	-2.3779	-1.4795	158	-0.2539	-0.4053	1.2256	0.5566
9	-0.293	-0.293	1.2305	0.5811	59	-0.0293	-0.2295	1.2305	0.4199	109	0.0244	0.4004	1.2451	-1.1475	159	-0.2881	-0.332	1.2451	0.5762
10	-0.2783	-0.2051	1.2549	0.6299	60	-0.1123	-0.3027	1.2646	0.5957	110	0.0537	0.4102	-0.6494	-0.5811	160	-0.3174	-0.249	-9.6191	-2.7393
11	-0.2539	-0.1172	1.2305	0.6006	61	-0.166	-0.3809	1.2256	0.4932	111	0.1563	0.3955	1.2354	-0.5029	161	-0.3369	-0.1416	1.25	-1.2695
12	-0.2588	-0.0244	1.2598	0.6494	62	-0.1855	-0.4297	1.2695	0.5811	112	0.2002	0.3662	0.7471	0.127	162	-0.2881	-0.0488	-6.8799	-2.998
13	-0.2197	0.0635	1.2256	0.625	63	-0.1709	-0.4688	1.2207	0.5127	113	0.1416	0.3125	1.2451	0.0195	163	-0.2197	0.0635	1.25	-1.4648
14	-0.1172	0.1563	1.2549	0.6641	64	-0.1611	-0.4785	1.2695	0.5664	114	0.0439	0.2441	1.2549	0.498	164	-0.0244	0.1563	-4.585	-2.4219
15	0.0781	0.2295	-10	-2.8174	65	-0.1709	-0.4834	1.2158	0.5029	115	-0.0146	0.1611	1.2402	0.3271	165	0.1465	0.249	1.25	-1.1523
16	0.1904	0.2979	1.2598	-1.2646	66	-0.1807	-0.4639	1.2598	0.6055	116	0	0.0684	1.2598	0.6055	166	0.249	0.3174	-2.6074	-1.6406
17	0.1807	0.3418	-7.2119	-3.0811	67	-0.2051	-0.4346	1.2158	0.5322	117	0.0244	-0.0342	1.2598	0.4736	167	0.1611	0.3857	1.25	-1.2305
18	0.0928	0.3809	1.25	-1.4844	68	-0.2148	-0.3809	1.2695	0.6201	118	0.0195	-0.127	1.2598	0.6152	168	0.0781	0.4248	-0.9424	-0.7422
19	0.0537	0.3906	-4.9805	-2.5537	69	-0.2295	-0.3174	1.2109	0.542	119	-0.0684	-0.2197	1.2402	0.5371	169	0.0146	0.459	1.25	-0.5615
20	0.0586	0.3955	1.2549	-1.1963	70	-0.2393	-0.2344	1.2793	0.6299	120	-0.1514	-0.3027	1.2109	0.5713	170	0.0732	0.459	0.498	-0.0146
21	0.1563	0.3662	-2.7832	-1.7285	71	-0.249	-0.1514	1.2158	0.5566	121	-0.1953	-0.376	1.2354	0.5273	171	0.1807	0.4541	1.2549	-0.0244
22	0.1758	0.332	1.2549	-1.2793	72	-0.2539	-0.0635	1.2598	0.6396	122	-0.2002	-0.4346	1.2598	0.5615	172	0.1904	0.4053	1.2451	0.4443
23	0.1172	0.2734	-1.0303	-0.8105	73	-0.2148	0.0244	-9.3945	-2.6563	123	-0.1709	-0.4688	1.2305	0.5176	173	0.1221	0.3564	1.2451	0.3418
24	0.0146	0.21	1.25	-0.6104	74	-0.1221	0.1123	1.2695	-1.167	124	-0.1611	-0.4932	1.2598	0.5957	174	0.0439	0.2783	1.2549	0.5811
25	-0.0244	0.1221	0.4004	-0.0977	75	0.0977	0.1855	-6.6602	-2.8906	125	-0.166	-0.4932	1.2354	0.542	175	0.0244	0.1953	1.2402	0.5029
26	-0.0195	0.0439	1.25	-0.0928	76	0.2246	0.2588	1.2646	-1.3477	126	-0.1953	-0.4834	1.2549	0.5957	176	0.0391	0.0879	1.2549	0.6055
27	0.0146	-0.0586	1.2402	0.376	77	0.2051	0.3125	-4.3994	-2.3291	127	-0.2295	-0.4492	1.2305	0.542	177	0.0293	-0.0146	1.2451	0.5811
28	-0.0049	-0.1416	1.2451	0.2881	78	0.1074	0.3564	1.2646	-1.0498	128	-0.2344	-0.4004	1.2695	0.6006	178	-0.0195	-0.127	1.2598	0.5859
29	-0.0439	-0.2393	1.2549	0.5127	79	0.0098	0.376	-2.373	-1.5479	129	-0.2686	-0.332	1.2305	0.5566	179	-0.1025	-0.2148	1.2402	0.6006
30	-0.1123	-0.3125	1.2451	0.4443	80	0.0488	0.3906	1.2598	-1.1035	130	-0.2832	-0.249	1.25	0.5957	180	-0.166	-0.3174	1.2549	0.5566
31	-0.1563	-0.3906	1.25	0.5371	81	0.1465	0.3711	-0.6641	-0.6396	131	-0.3076	-0.1514	-9.209	-2.6123	181	-0.21	-0.3857	1.2402	0.5762
32	-0.1855	-0.4297	1.25	0.5273	82	0.1953	0.3467	1.25	-0.4492	132	-0.249	-0.0586	1.25	-1.1768	182	-0.1807	-0.4541	1.2549	0.5762
33	-0.1758	-0.4736	1.2549	0.5273	83	0.127	0.293	0.6934	0.0586	133	-0.21	0.0391	-6.6797	-2.8906	183	-0.1611	-0.4834	1.2354	0.5811
34	-0.166	-0.4736	1.2402	0.5566	84	0.0391	0.2295	1.25	0.0537	134	-0.0342	0.1318	1.25	-1.3867	184	-0.1611	-0.5127	1.25	0.5713
35	-0.1465	-0.4834	1.2549	0.5225	85	-0.0391	0.1465	1.2402	0.4248	135	0.1514	0.2197	-4.3994	-2.334	185	-0.2002	-0.5029	1.2305	0.5811
36	-0.166	-0.4541	1.2402	0.5566	86	-0.0391	0.0635	1.25	0.3662	136	0.2344	0.2881	1.2549	-1.0791	186	-0.2344	-0.498	1.2598	0.5615
37	-0.1904	-0.4297	1.25	0.5615	87	-0.0049	-0.0391	1.2451	0.5371	137	0.1611	0.3516	-2.3975	-1.543	187	-0.2686	-0.4492	1.2402	0.5762
38	-0.2148	-0.3613	1.2451	0.5957	88	0.0098	-0.127	1.2451	0.5029	138	0.0684	0.3906	1.2451	-1.1475	188	-0.2734	-0.4053	1.2549	0.5518
39	-0.21	-0.3076	1.25	0.5762	89	-0.0293	-0.2197	1.25	0.5469	139	0.0146	0.4248	-0.7227	-0.6445	189	-0.3027	-0.3174	-10	-2.959
40	-0.2197	-0.21	1.2305	0.6152	90	-0.1221	-0.2979	1.2451	0.5664	140	0.0635	0.4346	1.25	-0.4932	190	-0.3223	-0.2393	1.2451	-1.4258
41	-0.2246	-0.1416	1.25	0.5908	91	-0.166	-0.376	1.25	0.5322	141	0.1611	0.4248	0.6543	0.0635	191	-0.3564	-0.127	-7.4609	-3.2373
42	-0.2441	-0.0391	1.2305	0.6299	92	-0.1904	-0.4297	1.2402	0.5811	142	0.1953	0.3906	1.25	0.0342	192	-0.3027	-0.0342	1.2402	-1.6406
43	-0.21	0.0391	1.2451	0.6006	93	-0.1904	-0.4639	1.25	0.5127	143	0.1172	0.3369	1.2451	0.4688	193	-0.2148	0.083	-5.3271	-2.7246
44	-0.1025	0.1367	-9.6338	-2.6563	94	-0.1758	-0.4834	1.2451	0.5615	144	0.0391	0.2637	1.2451	0.3613	194	-0.0195	0.1709	1.2451	-1.3672
45	0.083	0.2002	1.2402	-1.2451	95	-0.2002	-0.4834	1.2549	0.5469	145	-0.0098	0.1807	1.2549	0.5859	195	0.1709	0.2686	-3.1299	-1.8945
46	0.2197	0.2783	-6.8652	-2.9102	96	-0.2148	-0.4688	1.2305	0.5811	146	0.0049	0.0781	1.25	0.498	196	0.2441	0.332	1.25	-1.4355
47	0.1855	0.3174	1.2451	-1.4404	97	-0.2295	-0.4346	1.25	0.5518	147	0.0049	-0.0195	1.2549	0.6006	197	0.166	0.4053	-1.3574	-0.9375
48	0.0977	0.3662	-4.5996	-2.3535	98	-0.2295	-0.3906	1.2354	0.5908	148	-0.0098	-0.127	1.2402	0.5664	198	0.083	0.4395	1.2451	-0.7568
49	0.0244	0.376	1.2402	-1.1475	99	-0.2295	-0.3271	1.25	0.5615	149	-0.0732	-0.2197	1.2598	0.5859	199	0.0195	0.4785	0.1514	-0.1611
50	0.0684	0.3906	-2.5	-1.5527	100	-0.2441	-0.2441	1.2305	0.6006	150	-0.1416	-0.3076	1.2402	0.5713	200	0.0781	0.4736	1.2402	-0.2051



Tinggi Gel 2 cm  
Periode 1.6 dt

No	Load cell (Volt)	Seasim (Volt)	Trimmeter 1 (Volt)	Trimmeter 2 (Volt)	No	Load cell (Volt)	Seasim (Volt)	Trimmeter 1 (Volt)	Trimmeter 2 (Volt)	No	Load cell (Volt)	Seasim (Volt)	Trimmeter 1 (Volt)	Trimmeter 2 (Volt)	No	Load cell (Volt)	Seasim (Volt)	Trimmeter 1 (Volt)	Trimmeter 2 (Volt)
1	-0.21	-0.4004	1.2402	0.4443	51	0.1563	0.3613	1.2354	-1.2207	101	-0.2686	-0.1611	1.2402	0.5615	151	-0.1953	-0.3809	1.2598	0.5615
2	-0.2539	-0.4443	1.2695	0.5811	52	0.1807	0.3369	-0.8008	-0.8494	102	-0.2686	-0.0732	-9.126	-2.5439	152	-0.1855	-0.4443	1.2402	0.5518
3	-0.2441	-0.4736	1.2354	0.5225	53	0.1025	0.2734	1.2402	-0.5713	103	-0.2148	0.0195	1.25	-1.1963	153	-0.1758	-0.4785	1.2549	0.5859
4	-0.2441	-0.4785	1.2549	0.5713	54	0.0195	0.2197	0.5859	0.0439	104	-0.083	0.1123	-6.4893	-2.7832	154	-0.1563	-0.498	1.2305	0.5615
5	-0.2246	-0.4785	1.2451	0.5566	55	-0.0244	0.1318	1.2354	-0.0586	105	0.1172	0.1953	1.2402	-1.3818	155	-0.1953	-0.498	1.2598	0.5811
6	-0.2588	-0.4541	1.2549	0.5615	56	-0.0244	0.0488	1.25	0.459	106	0.2197	0.2637	-4.3018	-2.2363	156	-0.2051	-0.4883	1.2354	0.5566
7	-0.2783	-0.4199	1.2354	0.5469	57	0.0098	-0.0488	1.2354	0.2734	107	0.1855	0.3223	1.2402	-1.0791	157	-0.2441	-0.4541	1.2646	0.5762
8	-0.3125	-0.3564	1.2646	0.6104	58	0.0195	-0.1318	1.2646	0.5713	108	0.0684	0.3711	-2.3779	-1.4795	158	-0.2539	-0.4053	1.2256	0.5566
9	-0.293	-0.293	1.2305	0.5811	59	-0.0293	-0.2295	1.2305	0.4199	109	0.0244	0.4004	1.2451	-1.1475	159	-0.2881	-0.332	1.2451	0.5762
10	-0.2783	-0.2051	1.2549	0.6299	60	-0.1123	-0.3027	1.2646	0.5957	110	0.0537	0.4102	-0.6494	-0.5811	160	-0.3174	-0.249	-9.6191	-2.7393
11	-0.2539	-0.1172	1.2305	0.6006	61	-0.166	-0.3809	1.2256	0.4932	111	0.1563	0.3955	1.2354	-0.5029	161	-0.3369	-0.1416	1.25	-1.2695
12	-0.2588	-0.0244	1.2598	0.6494	62	-0.1855	-0.4297	1.2695	0.5811	112	0.2002	0.3662	0.7471	0.127	162	-0.2881	-0.0488	-6.8799	-2.998
13	-0.2197	0.0635	1.2256	0.625	63	-0.1709	-0.4688	1.2207	0.5127	113	0.1416	0.3125	1.2451	0.0195	163	-0.2197	0.0635	1.25	-1.4648
14	-0.1172	0.1563	1.2549	0.6641	64	-0.1611	-0.4785	1.2695	0.5664	114	0.0439	0.2441	1.2549	0.498	164	-0.0244	0.1563	-4.585	-2.4219
15	0.0781	0.2295	-10	-2.8174	65	-0.1709	-0.4834	1.2158	0.5029	115	-0.0146	0.1611	1.2402	0.3271	165	0.1465	0.249	1.25	-1.1523
16	0.1904	0.2979	1.2598	-1.2646	66	-0.1807	-0.4639	1.2598	0.6055	116	0	0.0684	1.2598	0.6055	166	0.249	0.3174	-2.6074	-1.6406
17	0.1807	0.3418	-7.2119	-3.0811	67	-0.2051	-0.4346	1.2158	0.5322	117	0.0244	-0.0342	1.2598	0.4736	167	0.1611	0.3857	1.25	-1.2305
18	0.0928	0.3809	1.25	-1.4844	68	-0.2148	-0.3809	1.2695	0.6201	118	0.0195	-0.127	1.2598	0.6152	168	0.0781	0.4248	-0.9424	-0.7422
19	0.0537	0.3906	-4.9805	-2.5537	69	-0.2295	-0.3174	1.2109	0.542	119	-0.0684	-0.2197	1.2402	0.5371	169	0.0146	0.459	1.25	-0.5615
20	0.0586	0.3955	1.2549	-1.1963	70	-0.2393	-0.2344	1.2793	0.6299	120	-0.1514	-0.3027	1.2109	0.5713	170	0.0732	0.459	0.498	-0.0146
21	0.1563	0.3662	-2.7832	-1.7285	71	-0.249	-0.1514	1.2158	0.5566	121	-0.1953	-0.376	1.2354	0.5273	171	0.1807	0.4541	1.2549	-0.0244
22	0.1758	0.332	1.2549	-1.2793	72	-0.2539	-0.0635	1.2598	0.6396	122	-0.2002	-0.4346	1.2598	0.5615	172	0.1904	0.4053	1.2451	0.4443
23	0.1172	0.2734	-1.0303	-0.8105	73	-0.2148	0.0244	-9.3945	-2.6563	123	-0.1709	-0.4688	1.2305	0.5176	173	0.1221	0.3564	1.2451	0.3418
24	0.0146	0.21	1.25	-0.6104	74	-0.1221	0.1123	1.2695	-1.167	124	-0.1611	-0.4932	1.2598	0.5957	174	0.0439	0.2783	1.2549	0.5811
25	-0.0244	0.1221	0.4004	-0.0977	75	0.0977	0.1855	-6.6602	-2.8906	125	-0.166	-0.4932	1.2354	0.542	175	0.0244	0.1953	1.2402	0.5029
26	-0.0195	0.0439	1.25	-0.0928	76	0.2246	0.2588	1.2646	-1.3477	126	-0.1953	-0.4834	1.2549	0.5957	176	0.0391	0.0879	1.2549	0.6055
27	0.0146	-0.0586	1.2402	0.376	77	0.2051	0.3125	-4.3994	-2.3291	127	-0.2295	-0.4492	1.2305	0.542	177	0.0293	-0.0146	1.2451	0.5811
28	-0.0049	-0.1416	1.2451	0.2881	78	0.1074	0.3564	1.2646	-1.0498	128	-0.2344	-0.4004	1.2695	0.6006	178	-0.0195	-0.127	1.2598	0.5859
29	-0.0439	-0.2393	1.2549	0.5127	79	0.0098	0.376	-2.373	-1.5479	129	-0.2686	-0.332	1.2305	0.5566	179	-0.1025	-0.2148	1.2402	0.6006
30	-0.1123	-0.3125	1.2451	0.4443	80	0.0488	0.3906	1.2598	-1.1035	130	-0.2832	-0.249	1.25	0.5957	180	-0.166	-0.3174	1.2549	0.5566
31	-0.1563	-0.3906	1.25	0.5371	81	0.1465	0.3711	-0.6641	-0.6396	131	-0.3076	-0.1514	-9.209	-2.6123	181	-0.21	-0.3857	1.2402	0.5762
32	-0.1855	-0.4297	1.25	0.5273	82	0.1953	0.3467	1.25	-0.4492	132	-0.249	-0.0586	1.25	-1.1768	182	-0.1807	-0.4541	1.2549	0.5762
33	-0.1758	-0.4736	1.2549	0.5273	83	0.127	0.293	0.6934	0.0586	133	-0.21	0.0391	-6.6797	-2.8906	183	-0.1611	-0.4834	1.2354	0.5811
34	-0.166	-0.4736	1.2402	0.5566	84	0.0391	0.2295	1.25	0.0537	134	-0.0342	0.1318	1.25	-1.3867	184	-0.1611	-0.5127	1.25	0.5713
35	-0.1465	-0.4834	1.2549	0.5225	85	-0.0391	0.1465	1.2402	0.4248	135	0.1514	0.2197	-4.3994	-2.334	185	-0.2002	-0.5029	1.2305	0.5811
36	-0.166	-0.4541	1.2402	0.5566	86	-0.0391	0.0635	1.25	0.3662	136	0.2344	0.2881	1.2549	-1.0791	186	-0.2344	-0.498	1.2598	0.5615
37	-0.1904	-0.4297	1.25	0.5615	87	-0.0049	-0.0391	1.2451	0.5371	137	0.1611	0.3516	-2.3975	-1.543	187	-0.2686	-0.4492	1.2402	0.5762
38	-0.2148	-0.3613	1.2451	0.5957	88	0.0098	-0.127	1.2451	0.5029	138	0.0684	0.3906	1.2451	-1.1475	188	-0.2734	-0.4053	1.2549	0.5518
39	-0.21	-0.3076	1.25	0.5762	89	-0.0293	-0.2197	1.25	0.5469	139	0.0146	0.4248	-0.7227	-0.6445	189	-0.3027	-0.3174	-10	-2.959
40	-0.2197	-0.21	1.2305	0.6152	90	-0.1221	-0.2979	1.2451	0.5664	140	0.0635	0.4346	1.25	-0.4932	190	-0.3223	-0.2393	1.2451	-1.4258
41	-0.2246	-0.1416	1.25	0.5908	91	-0.166	-0.376	1.25	0.5322	141	0.1611	0.4248	0.6543	0.0635	191	-0.3564	-0.127	-7.4609	-3.2373
42	-0.2441	-0.0391	1.2305	0.6299	92	-0.1904	-0.4297	1.2402	0.5811	142	0.1953	0.3906	1.25	0.0342	192	-0.3027	-0.0342	1.2402	-1.6406
43	-0.21	0.0391	1.2451	0.6006	93	-0.1904	-0.4639	1.25	0.5127	143	0.1172	0.3369	1.2451	0.4688	193	-0.2148	0.083	-5.3271	-2.7246
44	-0.1025	0.1367	-9.6338	-2.6563	94	-0.1758	-0.4834	1.2451	0.5615	144	0.0391	0.2637	1.2451	0.3613	194	-0.0195	0.1709	1.2451	-1.3672
45	0.083	0.2002	1.2402	-1.2451	95	-0.2002	-0.4834	1.2549	0.5469	145	-0.0098	0.1807	1.2549	0.5859	195	0.1709	0.2686	-3.1299	-1.8945
46	0.2197	0.2783	-6.8652	-2.9102	96	-0.2148	-0.4688	1.2305	0.5811	146	0.0049	0.0781	1.25	0.498	196	0.2441	0.332	1.25	-1.4355
47	0.1855	0.3174	1.2451	-1.4404	97	-0.2295	-0.4346	1.25	0.5518	147	0.0049	-0.0195	1.2549	0.6006	197	0.166	0.4053	-1.3574	-0.9375
48	0.0977	0.3662	-4.5996	-2.3535	98	-0.2295	-0.3906	1.2354	0.5908	148	-0.0098	-0.127	1.2402	0.5664	198	0.083	0.4395	1.2451	-0.7568
49	0.0244	0.376	1.2402	-1.1475	99	-0.2295	-0.3271	1.25	0.5615	149	-0.0732	-0.2197	1.2598	0.5859	199	0.0195	0.4785	0.1514	-0.1611
50	0.0684	0.3906	-2.5	-1.5527	100	-0.2441	-0.2441	1.2305	0.6006	150	-0.1416	-0.3076	1.2402	0.5713	200	0.0781	0.4736	1.2402	-0.2051



Tinggi Gel 2 cm  
Periode 1.7 dt

No	Load cell (Volt)	Seasim (Volt)	Trimmeter 1 (Volt)	Trimmeter 2 (Volt)	No	Load cell (Volt)	Seasim (Volt)	Trimmeter 1 (Volt)	Trimmeter 2 (Volt)	No	Load cell (Volt)	Seasim (Volt)	Trimmeter 1 (Volt)	Trimmeter 2 (Volt)	No	Load cell (Volt)	Seasim (Volt)	Trimmeter 1 (Volt)	Trimmeter 2 (Volt)
1	0.2002	0.249	1.2305	0.4297	51	-0.0635	-0.249	1.2305	0.4297	101	0.2637	0.0732	1.2256	0.3955	151	-0.0146	-0.0586	1.2451	0.2979
2	0.1709	0.332	1.2744	0.6641	52	-0.0781	-0.332	1.2744	0.6641	102	0.1758	0.166	1.25	0.708	152	-0.0342	-0.1514	0.957	0.6006
3	0.2539	0.3857	1.2305	0.498	53	-0.083	-0.4102	1.2305	0.4053	103	0.1611	0.2441	1.2354	0.415	153	-0.0684	-0.2344	1.25	0.2539
4	0.2588	0.4443	1.2744	0.7178	54	-0.0977	-0.4639	1.2549	0.6396	104	0.1758	0.3174	1.25	0.7373	154	-0.0928	-0.3174	0.957	0.5713
5	0.3027	0.4736	1.2256	0.5322	55	-0.0977	-0.5127	1.2305	0.3857	105	0.2393	0.3809	1.2354	0.4395	155	-0.0928	-0.3857	1.2402	0.2246
6	0.3223	0.4932	1.2695	0.7373	56	-0.1465	-0.542	1.2549	0.625	106	0.2734	0.4346	1.25	0.7568	156	-0.0928	-0.4541	0.9424	0.5371
7	0.3613	0.4883	1.2451	0.5469	57	-0.2002	-0.5615	1.2256	0.3613	107	0.2881	0.4736	1.2451	0.4541	157	-0.1123	-0.4932	1.2402	0.1953
8	0.3271	0.4785	1.2695	0.7471	58	-0.2344	-0.5615	1.2549	0.6104	108	0.3076	0.4932	1.2598	0.7715	158	-0.1367	-0.5322	0.8936	0.5078
9	0.2539	0.4346	1.2305	0.542	59	-0.249	-0.5566	1.2256	0.3516	109	0.3223	0.498	1.2402	0.459	159	-0.2246	-0.542	1.2402	0.1709
10	0.166	0.3857	1.2695	0.7422	60	-0.2197	-0.5273	1.2549	0.6104	110	0.3027	0.4785	1.25	0.7764	160	-0.2246	-0.5469	0.8301	0.4736
11	0.0928	0.3125	1.2256	0.5273	61	-0.2197	-0.4834	1.2305	0.3564	111	0.2197	0.4395	1.2695	0.4639	161	-0.249	-0.5322	1.2451	0.1465
12	0.0781	0.2393	1.2695	0.7227	62	-0.1318	-0.415	1.2549	0.6201	112	0.1611	0.3809	1.25	0.7813	162	-0.2002	-0.5029	0.8008	0.4541
13	0.0293	0.1416	1.2305	0.5078	63	-0.0928	-0.3369	1.2305	0.3662	113	0.0732	0.3027	1.2402	0.4443	163	-0.21	-0.4492	1.2354	0.1367
14	0.0146	0.0488	1.2695	0.708	64	0.0195	-0.2344	1.2598	0.6445	114	0.0586	0.2197	1.25	0.752	164	-0.1221	-0.3809	0.7666	0.4541
15	0	-0.0537	1.2256	0.4834	65	0.1367	-0.1318	1.2354	0.3955	115	0.0195	0.127	1.2402	0.4102	165	-0.0928	-0.2881	1.2402	0.1465
16	-0.0439	-0.1514	1.2646	0.6787	66	0.2197	-0.0342	1.2695	0.6787	116	0.0098	0.0293	1.2451	0.7275	166	0.0439	-0.2051	0.7275	0.4541
17	-0.0635	-0.2539	1.2256	0.4541	67	0.2588	0.0684	1.2354	0.4199	117	-0.0244	-0.0684	1.2354	0.3809	167	0.1416	-0.1025	1.25	0.166
18	-0.0928	-0.3369	1.2695	0.6543	68	0.2051	0.166	1.2598	0.7031	118	-0.0439	-0.1611	1.2402	0.6982	168	0.2441	-0.0146	0.7178	0.4736
19	-0.0879	-0.415	1.2256	0.4297	69	0.1758	0.249	1.2402	0.4492	119	-0.0635	-0.249	1.2354	0.3564	169	0.2637	0.083	1.2451	0.1758
20	-0.0977	-0.4639	1.2646	0.6299	70	0.1807	0.3223	1.2549	0.7275	120	-0.0928	-0.3271	1.2451	0.6738	170	0.1904	0.166	0.6885	0.4834
21	-0.0879	-0.5127	1.25	0.4102	71	0.2344	0.3857	1.2354	0.4888	121	-0.0781	-0.4004	1.2354	0.332	171	0.1758	0.249	1.2451	0.1904
22	-0.1465	-0.5322	1.2646	0.6201	72	0.2686	0.4395	1.2598	0.7471	122	-0.0879	-0.459	1.2402	0.6543	172	0.166	0.3125	0.6641	0.498
23	-0.2051	-0.5566	1.2207	0.3906	73	0.2832	0.4736	1.2305	0.4834	123	-0.0977	-0.5029	1.2402	0.3125	173	0.2246	0.3809	1.2451	0.2051
24	-0.2393	-0.5518	1.2598	0.6104	74	0.3223	0.498	1.2598	0.7568	124	-0.1514	-0.5371	1.2354	0.6396	174	0.2588	0.4248	0.6787	0.5127
25	-0.2588	-0.5469	1.2207	0.3809	75	0.3223	0.498	1.2354	0.4932	125	-0.2246	-0.5518	1.3135	0.3125	175	0.2441	0.4688	1.25	0.2197
26	-0.2344	-0.5225	1.2598	0.6055	76	0.3027	0.4834	1.2549	0.7666	126	-0.2393	-0.5566	1.2109	0.6396	176	0.2637	0.4834	0.6592	0.5225
27	-0.2295	-0.4834	1.2256	0.3809	77	0.2051	0.4443	1.2402	0.4883	127	-0.2588	-0.542	1.2305	0.2881	177	0.2832	0.4883	1.2451	0.2344
28	-0.1465	-0.415	1.2646	0.6152	78	0.1416	0.3906	1.2549	0.7617	128	-0.2197	-0.5176	1.2061	0.625	178	0.3027	0.4639	0.6055	0.5078
29	-0.0928	-0.3418	1.2256	0.3955	79	0.0879	0.3174	1.2354	0.4785	129	-0.21	-0.4639	1.2354	0.2832	179	0.2246	0.4297	1.25	0.2197
30	0.0244	-0.2393	1.2695	0.6396	80	0.0635	0.2295	1.2598	0.7471	130	-0.127	-0.3906	1.2012	0.6299	180	0.166	0.3613	0.5908	0.4883
31	0.1611	-0.1465	1.2305	0.4248	81	0.0439	0.1416	1.2354	0.4541	131	-0.083	-0.3027	1.2354	0.2979	181	0.0781	0.293	1.25	0.1953
32	0.2344	-0.0391	1.2695	0.6689	82	0.0049	0.0391	1.2549	0.7227	132	0.0293	-0.21	1.1963	0.6494	182	0.0537	0.2051	0.6006	0.4688
33	0.2783	0.0586	1.2354	0.4492	83	-0.0195	-0.0635	1.25	0.4297	133	0.1514	-0.1074	1.2402	0.3174	183	0.0098	0.1172	1.2451	0.1758
34	0.2051	0.1611	1.2695	0.6982	84	-0.0537	-0.1563	1.2549	0.6982	134	0.249	-0.0146	1.1963	0.6738	184	-0.0049	0.0244	0.5664	0.4346
35	0.1758	0.2393	1.2305	0.4834	85	-0.0684	-0.249	1.2305	0.4004	135	0.2686	0.0781	1.2451	0.3418	185	-0.0195	-0.0635	1.25	0.1367
36	0.1709	0.3271	1.2695	0.7227	86	-0.0684	-0.332	1.2549	0.6738	136	0.1904	0.1563	1.1865	0.6982	186	-0.0439	-0.1563	0.5322	0.3955
37	0.2197	0.3809	1.2354	0.498	87	-0.083	-0.4053	1.2256	0.376	137	0.1709	0.2393	1.2402	0.3613	187	-0.0635	-0.2344	1.2402	0.1074
38	0.2637	0.4395	1.2793	0.7422	88	-0.0928	-0.4639	1.2549	0.6494	138	0.166	0.3125	1.167	0.7129	188	-0.0732	-0.3174	0.5469	0.3711
39	0.2734	0.4736	1.2305	0.5176	89	-0.1074	-0.5078	1.2354	0.3516	139	0.2441	0.3809	1.2598	0.376	189	-0.0684	-0.3857	1.2451	0.083
40	0.3174	0.498	1.2598	0.7568	90	-0.166	-0.5371	1.2549	0.6299	140	0.2686	0.4346	1.1475	0.7324	190	-0.083	-0.4492	0.542	0.3516
41	0.3174	0.4932	1.2305	0.5225	91	-0.2051	-0.5566	1.2354	0.332	141	0.2637	0.4736	1.2451	0.3906	191	-0.0977	-0.4932	1.2451	0.0635
42	0.3174	0.4834	1.2646	0.7617	92	-0.2344	-0.5566	1.2549	0.6201	142	0.2686	0.4932	1.1182	0.7373	192	-0.1465	-0.5225	0.4932	0.3223
43	0.2295	0.4395	1.2354	0.5176	93	-0.249	-0.5469	1.2305	0.3223	143	0.2881	0.4932	1.25	0.3955	193	-0.2051	-0.5371	1.2402	0.0391
44	0.1709	0.3906	1.2646	0.7568	94	-0.2246	-0.5225	1.25	0.625	144	0.2979	0.4736	1.1035	0.7275	194	-0.2002	-0.5371	0.3955	0.2783
45	0.1025	0.3125	1.2305	0.5078	95	-0.2197	-0.4736	1.2305	0.3223	145	0.2148	0.4346	1.2451	0.3857	195	-0.2441	-0.5176	1.2402	0.0049
46	0.0732	0.2344	1.2646	0.7373	96	-0.1416	-0.4053	1.25	0.6299	146	0.166	0.3711	1.0449	0.6982	196	-0.1953	-0.4932	0.3369	0.249
47	0.0342	0.1367	1.2305	0.4883	97	-0.0879	-0.3174	1.2354	0.3418	147	0.0781	0.3027	1.2402	0.3564	197	-0.2002	-0.4346	1.2354	-0.0049
48	0.0146	0.0439	1.2646	0.7129	98	0.0342	-0.2197	1.25	0.6543	148	0.0488	0.2148	1.0596	0.6787	198	-0.1172	-0.3662	0.3418	0.2539
49	-0.0049	-0.0635	1.2354	0.4541	99	0.1465	-0.1221	1.2354	0.3662	149	0.0098	0.127	1.2451	0.3271	199	-0.0977	-0.2734	1.2451	0.0049
50	-0.0342	-0.1514	1.2598	0.6885	100	0.2393	-0.0244	1.25	0.6885	150	0.0049	0.0342	1.0205	0.6445	200	0.0488	-0.1855	0.3223	0.2637



Tinggi Gel 2 cm  
 Periode 1.8 dt

No	Load cell (Volt)	Seasim (Volt)	Trimmeter 1 (Volt)	Trimmeter 2 (Volt)	No	Load cell (Volt)	Seasim (Volt)	Trimmeter 1 (Volt)	Trimmeter 2 (Volt)	No	Load cell (Volt)	Seasim (Volt)	Trimmeter 1 (Volt)	Trimmeter 2 (Volt)	No	Load cell (Volt)	Seasim (Volt)	Trimmeter 1 (Volt)	Trimmeter 2 (Volt)
1	0.1953	0.4102	1.2402	0.5811	51	-0.1611	-0.1807	1.2256	0.5811	101	0.0342	-0.2295	1.2207	0.5225	151	-0.0293	0.4248	1.2305	0.625
2	0.2002	0.4541	1.2598	0.6201	52	-0.1758	-0.2588	1.2646	0.6104	102	0.2002	-0.1416	1.2744	0.6104	152	-0.0293	0.3809	1.2695	0.7031
3	0.1758	0.4785	1.2354	0.6494	53	-0.2344	-0.3467	1.2354	0.5615	103	0.2686	-0.0537	1.2305	0.5469	153	-0.0781	0.3271	1.2354	0.6152
4	0.1758	0.4932	1.2598	0.6641	54	-0.3223	-0.4004	1.2598	0.5859	104	0.2002	0.0488	1.2744	0.6348	154	-0.0977	0.2588	1.2598	0.6836
5	0.0977	0.4785	1.2402	0.6738	55	-0.3906	-0.4736	1.2256	0.5322	105	0.0928	0.1367	1.2256	0.5713	155	-0.1221	0.1807	1.2354	0.5957
6	0.0684	0.4639	1.2598	0.6738	56	-0.4053	-0.5029	1.2598	0.5713	106	0.0488	0.2344	1.2744	0.6641	156	-0.1611	0.0928	1.2646	0.6641
7	0.0098	0.4248	1.2402	0.6738	57	-0.4443	-0.5469	1.2256	0.5127	107	0.127	0.3076	1.2256	0.5957	157	-0.1709	-0.0098	1.2305	0.5762
8	-0.0293	0.3857	1.2598	0.6787	58	-0.415	-0.542	1.2598	0.5615	108	0.1953	0.3809	1.2793	0.6885	158	-0.1807	-0.1074	1.2646	0.6348
9	-0.0391	0.3223	1.2354	0.6641	59	-0.4102	-0.5566	1.2207	0.5029	109	0.2295	0.4297	1.2305	0.6152	159	-0.166	-0.2051	1.2354	0.5469
10	-0.0977	0.2637	1.2598	0.6641	60	-0.3662	-0.5225	1.2598	0.5566	110	0.2197	0.4736	1.2744	0.708	160	-0.1855	-0.2979	1.2598	0.6104
11	-0.1025	0.1807	1.2402	0.6494	61	-0.3662	-0.5029	1.2402	0.5029	111	0.1758	0.4883	1.2256	0.6299	161	-0.2637	-0.376	1.2305	0.5273
12	-0.1758	0.1025	1.2598	0.6445	62	-0.2832	-0.4395	1.2598	0.5615	112	0.1563	0.4932	1.2988	0.7227	162	-0.3271	-0.4443	1.2549	0.5811
13	-0.1465	0.0098	1.25	0.6299	63	-0.2539	-0.3906	1.2305	0.5127	113	0.0928	0.4736	1.2305	0.6348	163	-0.4297	-0.4932	1.2402	0.5029
14	-0.1514	-0.0781	1.2598	0.625	64	-0.1416	-0.3027	1.2646	0.5811	114	0.0732	0.459	1.2744	0.7178	164	-0.4199	-0.5322	1.25	0.5615
15	-0.1514	-0.1758	1.2354	0.6006	65	-0.0146	-0.2344	1.2256	0.5371	115	-0.0146	0.415	1.2256	0.625	165	-0.459	-0.5469	1.2256	0.4834
16	-0.1758	-0.2588	1.2646	0.6006	66	0.1465	-0.1318	1.2695	0.6055	116	-0.0342	0.376	1.2695	0.7031	166	-0.4346	-0.5566	1.25	0.5518
17	-0.21	-0.3418	1.2305	0.5713	67	0.2588	-0.0537	1.2354	0.5615	117	-0.0977	0.3174	1.2256	0.6152	167	-0.4443	-0.5566	1.2207	0.4688
18	-0.2783	-0.4004	1.2549	0.5713	68	0.21	0.0537	1.2695	0.6299	118	-0.1074	0.2588	1.2695	0.6885	168	-0.3711	-0.542	1.2549	0.5469
19	-0.3369	-0.4688	1.2305	0.5469	69	0.1318	0.127	1.2305	0.5859	119	-0.1172	0.1807	1.2305	0.5957	169	-0.3857	-0.5127	1.2354	0.4736
20	-0.376	-0.5029	1.25	0.5566	70	0.0732	0.2295	1.2646	0.6592	120	-0.1563	0.0977	1.2695	0.6738	170	-0.3076	-0.4688	1.2549	0.5518
21	-0.4199	-0.5371	1.2256	0.5273	71	0.1172	0.2979	1.2305	0.6055	121	-0.1611	0.0049	1.2305	0.5762	171	-0.3027	-0.4004	1.2354	0.4932
22	-0.4248	-0.542	1.2549	0.542	72	0.1563	0.3809	1.2744	0.6787	122	-0.1709	-0.0928	1.2744	0.6445	172	-0.1758	-0.3271	1.2598	0.5713
23	-0.4053	-0.5469	1.2256	0.5225	73	0.2246	0.4248	1.2354	0.6299	123	-0.1514	-0.1904	1.2305	0.5518	173	-0.0195	-0.2344	1.2402	0.5176
24	-0.3467	-0.5225	1.2598	0.542	74	0.2539	0.4785	1.2744	0.7031	124	-0.1709	-0.2783	1.2695	0.6201	174	0.2002	-0.1416	1.2695	0.5957
25	-0.332	-0.5029	1.2256	0.5225	75	0.2051	0.4932	1.2354	0.6445	125	-0.2295	-0.3613	1.2256	0.5273	175	0.3271	-0.0391	1.2354	0.5469
26	-0.2734	-0.4443	1.2549	0.5469	76	0.1611	0.5127	1.2744	0.7129	126	-0.3174	-0.4297	1.2646	0.6006	176	0.2637	0.0586	1.2598	0.6201
27	-0.2197	-0.3906	1.2646	0.542	77	0.0781	0.4932	1.2305	0.6445	127	-0.4004	-0.4834	1.2256	0.5029	177	0.1611	0.1563	1.2549	0.5713
28	-0.1221	-0.3125	1.2646	0.5713	78	0.0635	0.4785	1.2988	0.7227	128	-0.3955	-0.5176	1.2598	0.5762	178	0.1074	0.2393	1.2598	0.6494
29	0.0098	-0.2393	1.2305	0.5566	79	-0.0049	0.4248	1.2256	0.6445	129	-0.4492	-0.5371	1.2402	0.4834	179	0.1318	0.3223	1.2354	0.5957
30	0.1416	-0.1465	1.2646	0.5957	80	-0.0244	0.3857	1.2695	0.708	130	-0.4297	-0.542	1.2598	0.5664	180	0.2148	0.376	1.2646	0.6689
31	0.2344	-0.0635	1.2354	0.5762	81	-0.0977	0.3174	1.2305	0.6348	131	-0.4492	-0.5371	1.2207	0.4736	181	0.249	0.4346	1.2402	0.6201
32	0.1709	0.0391	1.2695	0.6152	82	-0.1025	0.2588	1.2744	0.6934	132	-0.3809	-0.5176	1.2646	0.5664	182	0.2881	0.4688	1.2598	0.6836
33	0.1074	0.1172	1.2402	0.6006	83	-0.1172	0.1709	1.2256	0.6152	133	-0.3906	-0.4834	1.2207	0.4736	183	0.249	0.4883	1.2451	0.6299
34	0.0684	0.21	1.2646	0.6445	84	-0.1465	0.0977	1.2744	0.6738	134	-0.2832	-0.4443	1.2646	0.5713	184	0.2148	0.4932	1.1719	0.6592
35	0.1074	0.2832	1.2354	0.625	85	-0.1514	-0.0049	1.2158	0.5908	135	-0.2588	-0.3857	1.2305	0.4883	185	0.1123	0.4834	1.2402	0.6152
36	0.1611	0.3613	1.2646	0.6689	86	-0.1709	-0.0879	1.2695	0.6494	136	-0.1465	-0.3174	1.2598	0.5908	186	0.0684	0.459	1.2598	0.6787
37	0.2148	0.4102	1.2354	0.6445	87	-0.1514	-0.1904	1.2256	0.5615	137	0.0098	-0.2393	1.2354	0.5127	187	-0.0195	0.4248	1.2354	0.6201
38	0.2393	0.4688	1.2646	0.6885	88	-0.166	-0.2686	1.2744	0.6201	138	0.2002	-0.1465	1.2744	0.6104	188	0	0.376	1.2646	0.6738
39	0.1953	0.4883	1.2354	0.6592	89	-0.2295	-0.3564	1.2207	0.5371	139	0.3125	-0.0488	1.2354	0.542	189	-0.0635	0.3223	1.2402	0.6152
40	0.1563	0.5078	1.2646	0.7031	90	-0.2979	-0.4199	1.2646	0.5957	140	0.2393	0.0537	1.2646	0.6348	190	-0.0684	0.249	1.2598	0.6641
41	0.083	0.498	1.2402	0.6689	91	-0.4102	-0.4834	1.2158	0.5127	141	0.1221	0.1465	1.2305	0.5664	191	-0.127	0.1709	1.2402	0.6055
42	0.0586	0.4883	1.2695	0.7031	92	-0.4102	-0.5176	1.2695	0.5762	142	0.0586	0.2393	1.2646	0.6592	192	-0.1514	0.0781	1.2549	0.6445
43	-0.0049	0.4395	1.2354	0.6592	93	-0.4443	-0.5469	1.2207	0.498	143	0.1172	0.3174	1.2402	0.5908	193	-0.1709	-0.0195	1.2402	0.5811
44	-0.0146	0.4053	1.2744	0.7031	94	-0.415	-0.542	1.2598	0.5664	144	0.2002	0.3857	1.2646	0.6836	194	-0.1758	-0.127	1.2842	0.625
45	-0.0732	0.332	1.2354	0.6543	95	-0.4199	-0.5469	1.2305	0.4932	145	0.2295	0.4297	1.2354	0.6104	195	-0.1758	-0.2197	1.2402	0.5615
46	-0.1025	0.2734	1.2646	0.6836	96	-0.376	-0.5176	1.2646	0.5664	146	0.249	0.4688	1.2744	0.7031	196	-0.2002	-0.3174	1.2549	0.5908
47	-0.1172	0.1807	1.2354	0.6348	97	-0.376	-0.4883	1.2207	0.4932	147	0.2197	0.4883	1.2354	0.625	197	-0.2881	-0.3906	1.2402	0.5273
48	-0.166	0.1074	1.2646	0.6641	98	-0.2881	-0.4297	1.2695	0.5713	148	0.1855	0.4883	1.2646	0.708	198	-0.332	-0.4639	1.25	0.5566
49	-0.1465	0.0049	1.2354	0.6104	99	-0.2246	-0.3809	1.2158	0.5029	149	0.1025	0.4785	1.2402	0.625	199	-0.3906	-0.5029	1.2305	0.498
50	-0.1855	-0.0781	1.2598	0.6348	100	-0.1221	-0.3027	1.2695	0.5908	150	0.0684	0.4541	1.2598	0.708	200	-0.4053	-0.542	1.25	0.5371



No	Load cell (Volt)	Seasim (Volt)	Trimmetr 1 (Volt)	Trimmetr 2 (Volt)	No	Load cell (Volt)	Seasim (Volt)	Trimmetr 1 (Volt)	Trimmetr 2 (Volt)	No	Load cell (Volt)	Seasim (Volt)	Trimmetr 1 (Volt)	Trimmetr 2 (Volt)	No	Load cell (Volt)	Seasim (Volt)	Trimmetr 1 (Volt)	Trimmetr 2 (Volt)	No	Load cell (Volt)	Seasim (Volt)	Trimmetr 1 (Volt)	Trimmetr 2 (Volt)
1	0.2783	-0.2051	1.3232	0.5859	51	0.166	0.5078	1.25	-1.0303	101	-0.1514	-0.3174	1.25	0.1465	151	0.1514	-0.4102	1.2451	0.4785					
2	0.2051	-0.1172	1.2402	0.625	52	0.1318	0.5078	-4.3311	-2.0508	102	-0.2393	-0.3857	0.7666	0.3809	152	0.2197	-0.3418	1.2598	0.5664					
3	0.166	-0.0244	1.2695	0.6104	53	0.1172	0.4736	1.2451	-0.9717	103	-0.2441	-0.4492	1.2451	0.1563	153	0.166	-0.2588	1.2402	0.498					
4	0.1563	0.0684	1.2305	0.6494	54	0.0537	0.4443	-3.9795	-1.9141	104	-0.3027	-0.5078	0.7861	0.3809	154	0.1416	-0.1855	1.2549	0.5859					
5	0.2148	0.1611	1.25	0.625	55	0.0342	0.3809	1.2451	-0.8887	105	-0.293	-0.5518	1.25	0.186	155	0.1318	-0.0977	1.3135	0.5518					
6	0.3418	0.2441	-0.7373	-0.0781	56	-0.0049	0.3223	-3.7158	-1.792	106	-0.293	-0.5811	0.8887	0.4102	156	0.1807	-0.0146	1.2598	0.6201					
7	0.3955	0.3174	1.2451	0.2246	57	0	0.2344	1.2402	-0.8252	107	-0.2148	-0.5908	1.25	0.1855	157	0.2344	0.0732	1.2402	0.5615					
8	0.4053	0.3857	-8.9844	-2.7197	58	-0.0146	0.1611	-3.418	-1.6748	108	-0.21	-0.5957	0.9961	0.4443	158	0.3223	0.1514	1.2598	0.6348					
9	0.3174	0.4395	1.25	-1.2695	59	0	0.0537	1.2451	-0.7666	109	-0.1465	-0.5859	1.25	0.2295	159	0.376	0.2246	1.2354	0.5811					
10	0.249	0.4834	-10	-3.8965	60	0.0049	-0.0342	-3.1299	-1.5674	110	-0.1367	-0.5713	1.0986	0.4883	160	0.3613	0.2881	1.2598	0.6543					
11	0.1904	0.5176	1.2451	-1.9678	61	0	-0.1318	1.25	-0.7178	111	-0.0586	-0.5273	1.2549	0.2734	161	0.2979	0.3516	1.2402	0.6055					
12	0.1807	0.5322	-10	-4.3945	62	-0.0928	-0.2148	-2.9004	-1.4795	112	0.0342	-0.4785	1.1768	0.5322	162	0.249	0.4004	1.2598	0.6689					
13	0.1758	0.5322	1.25	-2.2754	63	-0.1709	-0.2979	1.2451	-0.6689	113	0.1416	-0.4053	1.2549	0.3271	163	0.21	0.4395	1.2402	0.6201					
14	0.1465	0.5225	-9.8682	-4.4482	64	-0.2734	-0.3613	-2.6416	-1.3867	114	0.2344	-0.3369	1.2158	0.5762	164	0.1855	0.4688	1.2598	0.6787					
15	0.1221	0.4932	1.2451	-2.3291	65	-0.2686	-0.4346	1.2402	-0.7031	115	0.2393	-0.249	1.2598	0.3662	165	0.1611	0.4785	1.2354	0.6348					
16	0.0586	0.4492	-9.4531	-4.3701	66	-0.3223	-0.4834	-2.5488	-1.3135	116	0.1807	-0.166	1.2451	0.6104	166	0.1465	0.4688	1.2598	0.6885					
17	0.0342	0.3906	1.2402	-2.3047	67	-0.293	-0.5371	1.2402	-0.8154	117	0.1367	-0.0732	1.2598	0.4053	167	0.0879	0.4541	1.2402	0.6396					
18	-0.0049	0.3223	-9.043	-4.2432	68	-0.3076	-0.5615	-2.4072	-1.2158	118	0.1465	0.0049	1.2354	0.6348	168	0.0537	0.4102	1.2598	0.6885					
19	0	0.2441	1.2402	-2.2461	69	-0.2295	-0.5811	1.2402	-1.0205	119	0.2148	0.0977	1.2598	0.4492	169	0.0195	0.3613	1.2744	0.6445					
20	0	0.1563	-8.5254	-4.0625	70	-0.2148	-0.5762	-2.2754	-1.0742	120	0.3027	0.1709	1.2402	0.6592	170	0.0195	0.293	1.2598	0.6836					
21	-0.0098	0.0586	1.25	-2.168	71	-0.1416	-0.5762	1.25	-0.9717	121	0.3711	0.2539	1.2646	0.4785	171	-0.0049	0.2148	1.2402	0.625					
22	0.0098	-0.0342	-8.1299	-3.9014	72	-0.1416	-0.5518	-1.9385	-0.918	122	0.3662	0.3125	1.2402	0.6787	172	-0.0146	0.1318	1.2598	0.6641					
23	-0.0342	-0.1318	1.2402	-2.085	73	-0.0488	-0.5176	1.25	-0.8789	123	0.3223	0.3809	1.2549	0.5078	173	-0.0146	0.0439	1.2256	0.6055					
24	-0.1074	-0.2148	-7.8369	-3.7744	74	0.0146	-0.4639	-1.7529	-0.791	124	0.2539	0.4199	1.2402	0.6885	174	0.0146	-0.0488	1.2598	0.6396					
25	-0.21	-0.3027	1.2354	-2.0264	75	0.1465	-0.4004	1.25	-0.7666	125	0.21	0.4688	1.2549	0.5322	175	0.0098	-0.1367	1.2354	0.5762					
26	-0.2734	-0.3711	-7.6221	-3.6963	76	0.2246	-0.3223	-1.4795	-0.6641	126	0.1855	0.4785	1.2451	0.7031	176	-0.0391	-0.2197	1.2646	0.6152					
27	-0.3076	-0.4395	1.2549	-1.9824	77	0.2295	-0.2441	1.3623	-0.6299	127	0.1758	0.498	1.25	0.5469	177	-0.1367	-0.2979	1.2354	0.5518					
28	-0.3174	-0.4883	-7.5439	-3.6377	78	0.1758	-0.1514	-1.2891	-0.5273	128	0.1465	0.4785	1.2402	0.7031	178	-0.21	-0.3711	1.2598	0.5908					
29	-0.3076	-0.5322	1.2305	-1.958	79	0.1416	-0.0684	1.25	-0.542	129	0.0977	0.4639	1.25	0.5566	179	-0.2441	-0.4395	1.2207	0.5273					
30	-0.2832	-0.5518	-7.3389	-3.5693	80	0.1514	0.0293	-1.0938	-0.4248	130	0.0488	0.4102	1.2549	0.7031	180	-0.2881	-0.4932	1.2549	0.5664					
31	-0.2393	-0.5713	1.2256	-1.9238	81	0.2148	0.1123	1.25	-0.4541	131	0.0049	0.3662	1.2451	0.5566	181	-0.2881	-0.5469	1.2207	0.5029					
32	-0.2002	-0.5664	-7.1533	-3.4912	82	0.3027	0.1953	-0.8887	-0.3174	132	0.0049	0.2881	1.2451	0.6836	182	-0.2979	-0.5762	1.2549	0.5566					
33	-0.1611	-0.5615	1.2354	-1.8701	83	0.3711	0.2686	1.25	-0.3516	133	-0.0146	0.2246	1.25	0.542	183	-0.2246	-0.5957	1.2305	0.498					
34	-0.1416	-0.5273	-6.8066	-3.3545	84	0.3662	0.3369	-0.7324	-0.2197	134	-0.0244	0.127	1.2354	0.6592	184	-0.2051	-0.5957	1.2549	0.5469					
35	-0.0684	-0.4932	1.2402	-1.792	85	0.3271	0.3857	1.25	-0.2734	135	-0.0244	0.0488	1.2451	0.5273	185	-0.1514	-0.5957	1.2207	0.4883					
36	0.0049	-0.4346	-6.5625	-3.2275	86	0.2539	0.4346	-0.5078	-0.1123	136	0	-0.0537	1.25	0.6396	186	-0.1318	-0.5762	1.2646	0.5469					
37	0.1563	-0.3711	1.2402	-1.7188	87	0.2197	0.4736	1.25	-0.1855	137	-0.0049	-0.127	1.2451	0.5127	187	-0.0439	-0.542	1.1279	0.459					
38	0.2295	-0.2881	-6.2061	-3.0615	88	0.1855	0.498	-0.3418	-0.0195	138	-0.0586	-0.2295	1.25	0.6104	188	0.0586	-0.4883	1.2646	0.5371					
39	0.2344	-0.2197	1.2402	-1.6113	89	0.1807	0.5029	1.25	-0.1074	139	-0.1709	-0.2979	1.2402	0.4932	189	0.1465	-0.4248	1.2256	0.498					
40	0.166	-0.127	-6.001	-2.9297	90	0.1465	0.4932	-0.2051	0.0537	140	-0.2344	-0.3809	1.2451	0.5859	190	0.2197	-0.3516	1.2646	0.5664					
41	0.1318	-0.0488	1.25	-1.5137	91	0.1123	0.4688	1.3428	-0.0195	141	-0.2539	-0.4395	1.2402	0.4688	191	0.1855	-0.2686	1.2305	0.5176					
42	0.1514	0.0537	-5.7227	-2.7783	92	0.0488	0.4297	0.0098	0.1563	142	-0.2832	-0.5078	1.2451	0.5566	192	0.1416	-0.1855	1.2646	0.5908					
43	0.2246	0.1318	1.2402	-1.4258	93	0.0195	0.376	1.25	0.0146	143	-0.2832	-0.542	1.2402	0.4541	193	0.1221	-0.1074	1.2256	0.5371					
44	0.332	0.2246	-5.415	-2.6221	94	-0.0049	0.3076	0.1709	0.21	144	-0.2881	-0.5811	1.25	0.5518	194	0.1465	-0.0244	1.2891	0.6201					
45	0.3809	0.2881	1.2695	-1.3135	95	0	0.2295	1.2451	0.0537	145	-0.2148	-0.5859	1.2354	0.4492	195	0.2197	0.0635	1.2305	0.5664					
46	0.3809	0.3662	-5.1611	-2.4658	96	-0.0098	0.1367	0.3369	0.2539	146	-0.21	-0.5957	1.2549	0.542	196	0.3174	0.1465	1.2744	0.6396					
47	0.3223	0.4102	1.2402	-1.2207	97	-0.0244	0.0439	1.25	0.0879	147	-0.1367	-0.5811	1.2451	0.4492	197	0.3809	0.2197	1.2305	0.5859					
48	0.2637	0.4688	-4.8389	-2.3145	98	-0.0049	-0.0586	0.4932	0.3027	148	-0.0977	-0.5713	1.2549	0.542	198	0.3662	0.2979	1.2695	0.6738					
49	0.2148	0.4883	1.2451	-1.1279	99	0.0098	-0.1514	1.25	0.1123	149	-0.0391	-0.5273	1.2402	0.4639	199	0.3125	0.3564	1.2256	0.6152					
50	0.166	0.5176	-4.4873	-2.1582	100	-0.0684	-0.2393	0.6445	0.3467	150	0.0684	-0.4785	1.2549	0.5518	200	0.249	0.415	1.2744	0.7227					



Tinggi Gel 2 cm  
Periode 2.0 dt

No	Load cell (Volt)	Seasim (Volt)	Trimmeter 1 (Volt)	Trimmeter 2 (Volt)	No	Load cell (Volt)	Seasim (Volt)	Trimmeter 1 (Volt)	Trimmeter 2 (Volt)	No	Load cell (Volt)	Seasim (Volt)	Trimmeter 1 (Volt)	Trimmeter 2 (Volt)	No	Load cell (Volt)	Seasim (Volt)	Trimmeter 1 (Volt)	Trimmeter 2 (Volt)
1	-0.2051	-0.0928	1.2939	0.6348	51	-0.2734	-0.6006	-5.1855	-2.2021	101	0.2148	0.0098	1.25	0.166	151	0.0781	0.5322	1.2549	0.6689
2	-0.2979	-0.1855	1.2061	0.5615	52	-0.2246	-0.6104	1.2354	-1.1035	102	0.3711	0.0977	0.0195	0.2734	152	0.0195	0.5029	1.2402	0.6006
3	-0.3076	-0.2539	1.2695	0.6348	53	-0.1563	-0.5713	-6.1816	-2.6855	103	0.4443	0.1953	1.2549	0.0195	153	-0.0244	0.4688	1.2549	0.6787
4	-0.332	-0.3369	1.2061	0.5518	54	0.0195	-0.5518	1.2451	-1.377	104	0.4053	0.2686	-0.6689	0.0293	154	-0.0098	0.4199	1.2402	0.5664
5	-0.3174	-0.3955	1.2646	0.6299	55	0.2197	-0.4834	-7.0654	-3.1152	105	0.2783	0.3564	1.2549	-0.1807	155	-0.0342	0.3613	1.25	0.6738
6	-0.3223	-0.4639	1.2109	0.542	56	0.3369	-0.4248	1.25	-1.6064	106	0.1953	0.4102	-1.4258	-0.2637	156	-0.0537	0.293	1.2451	0.5225
7	-0.3174	-0.5127	1.2646	0.6201	57	0.2734	-0.332	-8.2275	-3.6084	107	0.1709	0.4688	1.25	-0.4102	157	-0.0732	0.2197	1.25	0.6689
8	-0.2979	-0.5566	1.2061	0.5322	58	0.1465	-0.2637	1.2451	-1.8848	108	0.1855	0.498	-2.2021	-0.5762	158	-0.0684	0.1416	1.2549	0.4834
9	-0.2832	-0.5762	1.2695	0.6152	59	0.083	-0.1611	-9.7412	-4.2285	109	0.1807	0.5225	1.2451	-0.0342	159	-0.0781	0.0537	1.2402	0.6641
10	-0.2832	-0.5957	1.2158	0.5273	60	0.0928	-0.083	1.2402	-2.2266	110	0.1416	0.5225	-3.1055	-1.0791	160	-0.1318	-0.0391	1.2451	0.4199
11	-0.2686	-0.5908	1.2695	0.6201	61	0.2051	0.0244	-6.3184	-3.5107	111	0.0488	0.5225	1.2549	-0.3418	161	-0.21	-0.127	1.2207	0.6396
12	-0.2393	-0.5908	1.2402	0.5371	62	0.3613	0.1025	1.2598	-1.8164	112	0.0195	0.4932	-3.96	-1.5332	162	-0.2588	-0.2148	1.2354	0.3467
13	-0.1514	-0.5664	1.2695	0.6299	63	0.4492	0.2051	1.2402	-0.8447	113	-0.0146	0.4639	1.25	-0.6006	163	-0.3027	-0.2979	0.8545	0.5176
14	-0.0049	-0.5371	1.2207	0.542	64	0.4004	0.2686	1.2695	-0.3027	114	-0.0146	0.4102	-4.9805	-2.0068	164	-0.3271	-0.376	1.25	0.2148
15	0.2002	-0.4785	1.2793	0.5957	65	0.2637	0.3516	1.2402	0.0684	115	-0.0488	0.3613	1.2549	-0.8936	165	-0.3418	-0.4443	0.2002	0.2783
16	0.332	-0.4199	1.2256	0.5322	66	0.1807	0.4004	1.2549	0.2686	116	-0.0537	0.2881	-6.0254	-2.5049	166	-0.3174	-0.5078	1.25	0.0195
17	0.2979	-0.332	1.2744	0.6006	67	0.1611	0.4688	1.2402	0.4346	117	-0.0781	0.2148	1.25	-1.1865	167	-0.3076	-0.5566	-0.4883	-0.0098
18	0.1611	-0.2588	1.2207	0.542	68	0.1904	0.4883	1.2549	0.5078	118	-0.0732	0.127	-6.8408	-2.9443	168	-0.2979	-0.5957	1.2402	-0.21
19	0.0879	-0.1611	1.2744	0.6152	69	0.1807	0.5225	1.2402	0.5908	119	-0.0977	0.0488	1.25	-1.4551	169	-0.293	-0.6104	-1.1865	-0.3174
20	0.0879	-0.0781	1.2256	0.542	70	0.1318	0.5176	1.2646	0.6201	120	-0.1123	-0.0485	-8.0371	-3.4766	170	-0.2881	-0.6201	1.2451	-0.4688
21	0.2051	0.0244	1.2744	0.6396	71	0.0488	0.5273	1.2451	0.6641	121	-0.2051	-0.1318	1.25	-1.7725	171	-0.2832	-0.6201	-2.0166	-0.6592
22	0.3613	0.1074	1.2305	0.5469	72	0.0098	0.4932	1.2549	0.6689	122	-0.2539	-0.2246	-9.5508	-4.1455	172	-0.2441	-0.6055	1.2451	-0.2148
23	0.4395	0.2051	1.2793	0.6738	73	-0.0146	0.4736	1.2402	0.6934	123	-0.293	-0.2979	1.2451	-2.1631	173	-0.166	-0.5811	-2.9004	-1.1475
24	0.376	0.2734	1.2256	0.5371	74	-0.0342	0.415	1.1768	0.6787	124	-0.3125	-0.376	-9.8633	-4.502	174	-0.0342	-0.5371	1.25	-0.4053
25	0.2588	0.3516	1.2744	0.6934	75	-0.0439	0.3711	1.2402	0.6885	125	-0.3369	-0.4443	1.2549	-2.3828	175	0.2002	-0.4785	-3.6865	-1.5771
26	0.1758	0.4053	1.2354	0.5273	76	-0.0391	0.2881	1.2549	0.6885	126	-0.3125	-0.5176	1.2256	-1.2646	176	0.3809	-0.4102	1.2598	-0.6445
27	0.1758	0.4639	1.2646	0.7275	77	-0.0488	0.2295	1.2402	0.6885	127	-0.3076	-0.5664	1.2695	-0.5859	177	0.3613	-0.3271	-4.6289	-2.002
28	0.1758	0.4883	1.2354	0.5127	78	-0.0635	0.1367	1.2549	0.6348	128	-0.2881	-0.6006	1.2305	-0.1855	178	0.2344	-0.2441	1.25	-0.8838
29	0.1611	0.5225	1.2695	0.7471	79	-0.0781	0.0586	1.2402	0.6543	129	-0.293	-0.6201	1.2549	0.0684	179	0.1123	-0.1563	-5.7275	-2.4756
30	0.1172	0.5225	1.2354	0.4932	80	-0.1172	-0.0391	1.2549	0.6006	130	-0.2637	-0.6299	1.2305	0.2197	180	0.1221	-0.0635	1.2842	-1.1328
31	0.0537	0.5322	1.2646	0.7617	81	-0.1758	-0.1123	1.2549	0.6201	131	-0.2686	-0.6299	1.2549	0.3271	181	0.2148	0.0391	-6.5576	-2.8711
32	0.0146	0.5029	1.2354	0.459	82	-0.2539	-0.2002	1.25	0.5762	132	-0.2246	-0.6201	1.2305	0.3906	182	0.3662	0.1318	1.2646	-1.3574
33	-0.0293	0.4785	1.2549	0.7715	83	-0.3027	-0.2686	1.2354	0.5762	133	-0.1855	-0.5908	1.2549	0.4541	183	0.4443	0.2197	-7.5781	-3.3057
34	-0.0342	0.4199	1.2354	0.415	84	-0.3223	-0.3564	1.2451	0.5518	134	-0.0391	-0.5518	1.2305	0.4785	184	0.4199	0.3027	1.2549	-1.6016
35	-0.0391	0.3711	1.1328	0.7422	85	-0.3369	-0.415	1.2354	0.5225	135	0.1758	-0.4883	1.2549	0.5176	185	0.3125	0.376	-8.9014	-3.8525
36	-0.0342	0.2979	1.2354	0.3369	86	-0.3174	-0.4932	1.2451	0.5273	136	0.3564	-0.4199	1.2402	0.5322	186	0.2246	0.4346	1.2598	-1.8994
37	-0.0586	0.2344	0.6885	0.5957	87	-0.3027	-0.542	1.2354	0.4736	137	0.3564	-0.3369	1.2549	0.5664	187	0.1758	0.4883	-10	-4.4629
38	-0.0781	0.1367	1.2354	0.2051	88	-0.2979	-0.5908	1.2451	0.5273	138	0.2295	-0.2588	1.2305	0.5762	188	0.2002	0.5176	1.2646	-2.2412
39	-0.0684	0.0635	0.1172	0.3711	89	-0.2881	-0.6006	1.2402	0.4297	139	0.1123	-0.166	1.2598	0.6055	189	0.2051	0.5371	1.2256	-1.1621
40	-0.0977	-0.0391	1.2354	0.0146	90	-0.2686	-0.6201	1.2451	0.5273	140	0.1025	-0.0732	1.2354	0.6104	190	0.1807	0.5371	1.3232	-0.3955
41	-0.1758	-0.1123	-0.5078	0.0928	91	-0.2539	-0.6104	1.2402	0.3906	141	0.1953	0.0293	1.2598	0.5908	191	0.083	0.5225	1.2305	-0.0586
42	-0.2539	-0.2051	1.2305	-0.2197	92	-0.2295	-0.6104	1.2451	0.542	142	0.3564	0.1221	1.2402	0.6201	192	0.0342	0.498	1.2744	0.2686
43	-0.3076	-0.2734	-1.3232	-0.2539	93	-0.166	-0.5811	1.2402	0.3662	143	0.4395	0.2197	1.2549	0.6055	193	-0.0293	0.459	1.2207	0.3467
44	-0.3369	-0.3613	1.2305	-0.5127	94	-0.0146	-0.5518	1.2402	0.5615	144	0.4248	0.2979	1.2354	0.6396	194	-0.0342	0.4102	1.2695	0.5225
45	-0.3223	-0.415	-2.2217	-0.6445	95	0.1758	-0.4883	1.25	0.3418	145	0.2979	0.376	1.2598	0.6299	195	-0.0537	0.3467	1.2207	0.5029
46	-0.3076	-0.4932	1.2305	-0.1904	96	0.332	-0.4297	1.2451	0.5908	146	0.21	0.4395	1.2402	0.6543	196	-0.0684	0.2832	1.2646	0.6201
47	-0.3223	-0.5371	-3.1494	-1.2012	97	0.2832	-0.3418	1.2549	0.3174	147	0.1514	0.4932	1.2891	0.6592	197	-0.0879	0.2148	1.2256	0.5615
48	-0.3076	-0.5859	1.2305	-0.5176	98	0.1709	-0.2686	1.0693	0.5762	148	0.1709	0.5225	1.2402	0.6543	198	-0.0781	0.1367	1.2646	0.6592
49	-0.2979	-0.5908	-4.1162	-1.7041	99	0.0928	-0.1758	1.25	0.2686	149	0.1855	0.542	1.2646	0.6641	199	-0.083	0.0488	1.2207	0.5811
50	-0.2783	-0.6152	1.2402	-0.8154	100	0.1025	-0.0928	0.6152	0.459	150	0.166	0.542	1.2451	0.6348	200	-0.1514	-0.0439	1.2695	0.6641



Tinggi Gel 4 cm  
Periode 1,2 dt

No	Load cell (Volt)	Seasim (Volt)	Trimmetr 1 (Volt)	Trimmetr 2 (Volt)	No	Load cell (Volt)	Seasim (Volt)	Trimmetr 1 (Volt)	Trimmetr 2 (Volt)	No	Load cell (Volt)	Seasim (Volt)	Trimmetr 1 (Volt)	Trimmetr 2 (Volt)	No	Load cell (Volt)	Seasim (Volt)	Trimmetr 1 (Volt)	Trimmetr 2 (Volt)	No	Load cell (Volt)	Seasim (Volt)	Trimmetr 1 (Volt)	Trimmetr 2 (Volt)
1	0.1367	-0.5029	1.3721	0.5127	51	0.6152	-0.293	-8.0762	-3.2715	101	1.377	-0.0195	-0.6201	-0.2246	151	1.4502	0.3027	1.4355	0.791					
2	0.1025	-0.4199	1.4014	-0.0293	52	1.1768	-0.166	1.4063	-1.8115	102	1.5039	0.1514	1.4258	0.1611	152	1.0303	0.4346	1.4307	0.8154					
3	0.5859	-0.293	1.4355	0.752	53	1.4063	-0.0195	1.4697	-0.6055	103	1.4307	0.2979	1.4502	0.4541	153	0.6055	0.5225	1.4209	0.2979					
4	1.1377	-0.1611	1.4111	0.708	54	1.5381	0.1465	-8.4619	-3.1885	104	1.0498	0.4297	-1.5625	-0.3809	154	-0.0293	0.5859	1.4307	0.9082					
5	1.4209	-0.0098	1.4453	0.21	55	1.4844	0.3076	1.4551	-1.6895	105	0.625	0.5225	1.4209	0.1318	155	-0.3809	0.5957	-6.5576	-1.7773					
6	1.6113	0.1514	1.4355	0.8447	56	1.084	0.4248	1.4258	-0.5615	106	0.0098	0.5859	1.4111	0.3955	156	-0.2637	0.5957	1.3867	-1.0059					
7	1.5918	0.3125	1.4307	0.8398	57	0.6494	0.5322	-9.043	-3.2373	107	-0.3955	0.6006	0.0537	0.1172	157	-0.4883	0.5225	1.3477	-0.0586					
8	1.0352	0.4297	1.4355	0.4346	58	0.0439	0.5859	1.3867	-1.7578	108	-0.2588	0.5908	1.3574	0.3564	158	-0.459	0.4395	1.3232	0.2637					
9	0.5859	0.5322	1.4258	0.9033	59	-0.3564	0.6152	1.4258	-0.5566	109	-0.5029	0.5322	1.3574	0.5322	159	-0.5029	0.3027	1.3184	-0.293					
10	0.0977	0.5811	1.4014	0.8301	60	-0.249	0.5908	-6.5771	-2.5781	110	-0.4736	0.4395	-2.2461	-0.5518	160	-0.542	0.166	0.8887	0.5078					
11	-0.1709	0.6104	1.4111	0.3564	61	-0.4883	0.5371	1.377	-1.3477	111	-0.5029	0.3125	1.3232	-0.0928	161	-0.5664	-0.0146	1.2891	0.4883					
12	-0.3906	0.5811	1.4551	0.9033	62	-0.4639	0.4346	1.3184	-0.4248	112	-0.5469	0.166	1.3623	0.2979	162	-0.5713	-0.1318	1.3232	0.1904					
13	-0.498	0.5322	1.3477	0.8545	63	-0.5127	0.3076	-10	-4.3115	113	-0.5713	-0.0049	-4.7168	-1.46	163	-0.5713	-0.2734	0.6738	0.3955					
14	-0.4492	0.4297	1.333	0.1123	64	-0.5371	0.1465	1.2939	-2.6318	114	-0.5762	-0.1318	1.2939	-0.6885	164	-0.5615	-0.3809	1.3086	0.5029					
15	-0.498	0.3125	0.4297	0.6152	65	-0.5664	-0.0146	1.3281	-0.9668	115	-0.5664	-0.2686	1.3135	-0.0537	165	-0.5371	-0.4883	1.3086	0.4883					
16	-0.5664	0.1514	1.3037	0.6006	66	-0.5762	-0.1465	-6.9775	-3.1152	116	-0.5664	-0.3857	-4.8486	-1.7529	166	-0.4834	-0.5371	-0.9229	-0.1709					
17	-0.5615	0	1.3184	0.6592	67	-0.5811	-0.2783	1.3232	-1.9287	117	-0.5322	-0.4834	1.3135	-0.9131	167	-0.3467	-0.5615	1.3232	0.0732					
18	-0.5664	-0.1465	-0.4932	0.0293	68	-0.5664	-0.4004	1.2939	-0.6787	118	-0.4883	-0.5469	1.3379	-0.1758	168	-0.1221	-0.5322	1.4648	0.3955					
19	-0.5664	-0.2686	1.2988	0.2979	69	-0.5273	-0.4883	1.3184	-0.1758	119	-0.3564	-0.5615	-9.4531	-3.2422	169	0.0195	-0.4883	-2.1094	-0.6689					
20	-0.5811	-0.4053	1.3086	0.3906	70	-0.4688	-0.5518	1.3135	-0.5713	120	-0.1367	-0.5371	1.3623	-1.8701	170	-0.0146	-0.3906	1.4063	-0.0635					
21	-0.5615	-0.4932	-1.3672	-0.3613	71	-0.3369	-0.5615	1.2207	0.3516	121	0.1025	-0.4932	1.3867	-0.6494	171	0.5029	-0.2734	1.4111	0.2051					
22	-0.4736	-0.5566	1.3135	-0.0439	72	-0.1074	-0.5518	1.333	0.3662	122	0.0977	-0.3955	-8.1445	-3.1055	172	1.0352	-0.1367	0.1807	0.0439					
23	-0.3418	-0.5566	1.3672	0.3125	73	0.1074	-0.498	1.3916	0.0684	123	0.5713	-0.2783	1.4111	-1.6406	173	1.2988	-0.0049	1.4063	0.2734					
24	-0.0684	-0.5566	-4.375	-1.4111	74	0.127	-0.4199	1.3818	0.5762	124	1.0938	-0.1465	1.4307	-0.5859	174	1.4453	0.1709	1.4697	0.5322					
25	0.1025	-0.498	1.3818	-0.5566	75	0.5957	-0.293	1.4209	0.6494	125	1.3623	-0.0146	-6.2158	-2.4561	175	1.3721	0.3125	-0.4639	-0.0293					
26	0.0684	-0.415	1.416	-0.0195	76	1.1719	-0.1611	1.4209	0.127	126	1.4893	0.1563	1.4355	-1.25	176	0.9766	0.4395	1.4453	0.3613					
27	0.542	-0.2832	-1.6455	-0.6689	77	1.377	-0.0244	1.4502	0.8105	127	1.4063	0.2979	1.4453	-0.3271	177	0.5322	0.5273	1.4111	0.5078					
28	1.084	-0.1611	1.4258	-0.1318	78	1.5186	0.1465	1.416	0.7373	128	1.001	0.4297	-7.5977	-2.6904	178	-0.0049	0.5908	0.3809	0.3125					
29	1.3232	-0.0098	1.4502	0.2832	79	1.4355	0.2979	1.4746	0.2002	129	0.5469	0.5225	1.4209	-1.377	179	-0.3955	0.6055	1.3623	0.4492					
30	1.4893	0.1465	-1.7383	-0.5713	80	1.0596	0.4248	1.4209	0.8691	130	-0.0146	0.5859	1.4551	-0.3418	180	-0.3369	0.5908	1.416	0.6348					
31	1.4844	0.3076	1.4453	0.0293	81	0.6299	0.5176	1.4258	0.874	131	-0.3857	0.5957	-4.79	-1.8604	181	-0.5273	0.5273	0.0537	0.1904					
32	1.0596	0.4199	1.4453	0.3369	82	0.0195	0.5811	1.4063	0.3125	132	-0.2979	0.5859	1.3818	-0.8594	182	-0.4932	0.4346	1.3477	0.4492					
33	0.6152	0.5273	-2.1094	-0.5566	83	-0.3955	0.6055	1.4063	0.9277	133	-0.5225	0.5225	1.3428	-0.1221	183	-0.5127	0.3027	1.3037	0.5078					
34	0.0342	0.5713	1.3965	-0.0342	84	-0.2637	0.5908	1.3477	0.8057	134	-0.5078	0.4346	-8.418	-2.832	184	-0.5469	0.1611	-3.3838	-0.874					
35	-0.2979	0.6055	1.416	0.3613	85	-0.5078	0.5322	1.3672	0.2832	135	-0.5225	0.3076	1.3135	-1.6455	185	-0.5811	-0.0146	1.2842	-0.3564					
36	-0.3076	0.5811	-0.6934	-0.1953	86	-0.4785	0.4443	1.3086	0.8203	136	-0.542	0.1611	1.3232	-0.498	186	-0.5713	-0.1416	1.3477	0.1709					
37	-0.498	0.5371	1.3721	0.2295	87	-0.5127	0.3174	1.3232	0.7959	137	-0.5664	-0.0049	-10	-4.3115	187	-0.5713	-0.2783	-3.7305	-1.3037					
38	-0.4443	0.4346	1.3623	0.415	88	-0.5371	0.166	1.3037	0.708	138	-0.5762	-0.1318	1.3086	-2.5146	188	-0.5615	-0.3906	1.3281	-0.542					
39	-0.5029	0.3223	-4.6289	-1.3086	89	-0.5713	0	0.0488	0.2881	139	-0.5713	-0.2637	1.2988	-1.04	189	-0.5371	-0.4883	1.3086	-0.0488					
40	-0.5322	0.1611	1.2939	-0.6445	90	-0.5713	-0.1367	1.2842	0.3809	140	-0.5762	-0.3809	-10	-4.7412	190	-0.4736	-0.542	-6.7969	-2.2998					
41	-0.5566	0.0049	1.3281	0.0684	91	-0.5713	-0.2686	1.2988	0.5078	141	-0.5371	-0.4834	1.3135	-2.9102	191	-0.3516	-0.5566	1.3281	-1.3477					
42	-0.5811	-0.1416	-5.9717	-2.0508	92	-0.5615	-0.3906	-0.1172	0.0293	142	-0.4736	-0.542	1.333	-1.1768	192	-0.0977	-0.5371	1.3867	-0.3418					
43	-0.5664	-0.2686	1.3184	-1.0107	93	-0.542	-0.4834	1.3232	0.2783	143	-0.3564	-0.5566	1.3281	-0.5518	193	0.0439	-0.4834	-8.8135	-3.1787					
44	-0.5615	-0.4053	1.2988	-0.2686	94	-0.4883	-0.542	1.3232	0.3809	144	-0.0977	-0.5322	1.3818	-0.5668	194	0.0098	-0.3906	1.4111	-1.6504					
45	-0.5322	-0.4932	-7.2998	-2.5879	95	-0.3418	-0.5615	-2.9199	-0.8594	145	0.0977	-0.4883	1.3721	0.2539	195	0.5273	-0.2734	1.4111	-0.6104					
46	-0.4688	-0.5566	1.3086	-1.5479	96	-0.1123	-0.5469	1.3477	-0.3223	146	0.0586	-0.3906	1.3867	0.4053	196	1.0547	-0.1367	-5.2637	-2.1338					
47	-0.3418	-0.5615	1.3672	-0.4492	97	0.0977	-0.498	1.4111	0.1709	147	0.5322	-0.2783	1.416	0.0195	197	1.3184	0.0098	1.4209	-1.0889					
48	-0.1367	-0.5566	-10	-4.4189	98	0.0879	-0.4102	-1.9092	-0.7178	148	1.0693	-0.1416	1.4355	0.6689	198	1.4697	0.1807	1.46	-0.1758					
49	0.0928	-0.498	1.4014	-2.4902	99	0.5469	-0.2881	1.2842	-0.1465	149	1.3281	-0.0098	1.416	0.6445	199	1.4258	0.3223	-6.543	-2.3242					
50	0.127	-0.4199	1.3916	-1.04	100	1.123	-0.1563	1.4307	0.1953	150	1.4697	0.166	1.4355	0.2393	200	1.0059	0.4443	1.4404	-1.1035					



Tinggi Gel  
Periode

4 cm  
1.3 dt

No	Load cell (Volt)	Seasim (Volt)	Trimmeter 1 (Volt)	Trimmeter 2 (Volt)	No	Load cell (Volt)	Seasim (Volt)	Trimmeter 1 (Volt)	Trimmeter 2 (Volt)	No	Load cell (Volt)	Seasim (Volt)	Trimmeter 1 (Volt)	Trimmeter 2 (Volt)	No	Load cell (Volt)	Seasim (Volt)	Trimmeter 1 (Volt)	Trimmeter 2 (Volt)
1	-0.21	0.2979	1.377	0.498	51	-0.21	0.5713	-9.6191	-3.4863	101	-0.1709	0.708	1.4014	-2.0215	151	-0.127	0.6787	1.4063	-0.0342
2	-0.2002	0.127	-6.582	-1.8652	52	-0.21	0.4346	1.3721	-1.9385	102	-0.2197	0.6543	1.416	-0.6592	152	-0.1367	0.708	-10	-4.0332
3	-0.1855	-0.0586	1.3965	-0.9619	53	-0.21	0.2979	1.3965	-0.6689	103	-0.2148	0.5615	-9.6729	-3.54	153	-0.1758	0.6934	1.377	-2.3389
4	-0.1611	-0.1855	1.4502	-0.1221	54	-0.2002	0.1123	-7.0361	-2.8125	104	-0.2295	0.4395	1.3721	-1.9434	154	-0.2002	0.6494	1.416	-0.7715
5	-0.1025	-0.3418	-10	-3.7158	55	-0.1904	-0.0635	1.4111	-1.4697	105	-0.2051	0.2881	1.3867	-0.708	155	-0.2148	0.5566	-10	-3.9795
6	0.0977	-0.4688	1.4648	-2.2021	56	-0.166	-0.1904	1.4063	-0.5322	106	-0.21	0.1221	-7.1436	-2.8369	156	-0.2148	0.4395	1.4063	-2.168
7	0.4395	-0.5713	1.4746	-0.7422	57	-0.0684	-0.3467	-10	-4.1211	107	-0.1807	-0.0684	1.4014	-1.543	157	-0.2148	0.2881	1.3721	-0.874
8	0.5322	-0.625	1.4893	-0.166	58	0.1367	-0.4785	1.4453	-2.5635	108	-0.166	-0.2002	1.4258	-0.5273	158	-0.2051	0.127	-7.9443	-3.1348
9	0.7178	-0.6396	1.5186	-0.2637	59	0.498	-0.5811	1.4941	-0.8691	109	-0.0879	-0.3516	-10	-4.2773	159	-0.1855	-0.0586	1.4063	-1.7871
10	1.5381	-0.6348	1.5479	0.459	60	0.5664	-0.6396	1.4697	-0.3369	110	0.1221	-0.4688	1.4648	-2.6074	160	-0.1514	-0.1807	1.4453	-0.6006
11	2.0508	-0.5957	1.5771	0.542	61	0.7178	-0.6445	1.5381	-0.3174	111	0.4785	-0.5713	1.4697	-0.9424	161	-0.0977	-0.3418	-10	-4.4727
12	2.2412	-0.5176	1.5576	0.4346	62	1.4551	-0.6396	1.5234	0.3564	112	0.4443	-0.6299	1.4941	-0.332	162	0.1367	-0.459	1.4746	-2.7148
13	2.2266	-0.4004	1.2451	0.6006	63	1.9531	-0.5908	1.5479	0.5322	113	0.7666	-0.6445	1.3867	-0.4199	163	0.4834	-0.5664	1.4697	-1.0205
14	1.9727	-0.2637	1.543	0.6836	64	2.2461	-0.5078	1.5381	0.498	114	1.4795	-0.6299	1.543	0.3516	164	0.5225	-0.6299	1.5039	-0.332
15	1.4307	-0.127	1.5381	0.7227	65	2.1729	-0.3809	1.2646	0.5859	115	1.9434	-0.5859	1.5283	0.4639	165	0.7373	-0.6445	1.5039	-0.4541
16	0.8301	0.0293	-1.0596	-0.0488	66	1.8604	-0.249	1.5186	0.6055	116	2.1338	-0.4932	1.5625	0.1367	166	1.4453	-0.6348	1.543	0.3955
17	0.4395	0.2148	1.5039	0.3125	67	1.4307	-0.1074	1.5723	0.7471	117	2.1094	-0.3809	1.3477	0.6543	167	1.9141	-0.5811	1.5186	0.4541
18	0.0146	0.3711	1.4941	0.5469	68	0.708	0.0537	-0.7373	-0.0049	118	1.7969	-0.2393	1.543	0.708	168	2.1533	-0.4834	1.5674	0.6055
19	-0.1025	0.5127	-1.8604	-0.4053	69	0.2539	0.2246	1.5283	0.3906	119	1.3525	-0.1123	1.543	0.7324	169	2.041	-0.3662	0.9766	0.4248
20	-0.0391	0.6201	1.4453	0.0293	70	0.1074	0.376	1.4697	0.5273	120	0.6738	0.0586	-0.3271	0.1807	170	1.7432	-0.2246	1.5527	0.6006
21	-0.1318	0.6982	1.4404	0.4639	71	-0.0928	0.5176	-1.582	-0.2832	121	0.2441	0.2295	1.499	0.4199	171	1.3037	-0.1025	1.5381	0.6494
22	-0.166	0.7227	-8.3154	-2.4072	72	-0.0391	0.6201	1.4258	0.0488	122	0.0732	0.3906	1.499	0.6152	172	0.6396	0.0586	-0.5908	0.0635
23	-0.1709	0.7129	1.4014	-1.2451	73	-0.1123	0.6885	1.46	0.5176	123	-0.1074	0.5176	-1.25	-0.2002	173	0.1416	0.2197	1.4893	0.332
24	-0.1904	0.6592	1.4014	-0.249	74	-0.1416	0.7227	-7.6074	-2.2266	124	-0.0635	0.625	1.4453	0.1758	174	0.1172	0.3711	1.5039	0.5762
25	-0.21	0.5664	-7.6904	-2.6807	75	-0.1709	0.7129	1.416	-1.0742	125	-0.1074	0.6885	1.4307	0.5029	175	-0.127	0.5029	-1.665	-0.3613
26	-0.1953	0.4395	1.3965	-1.3818	76	-0.2051	0.6592	1.3867	-0.2197	126	-0.1611	0.7178	-7.0605	-1.9971	176	-0.0732	0.6055	1.4502	0.0781
27	-0.21	0.293	1.4111	-0.3418	77	-0.21	0.5713	-7.1045	-2.4414	127	-0.1611	0.6982	1.3916	-1.0059	177	-0.1367	0.6836	1.4258	0.4541
28	-0.1855	0.1172	-6.3477	-2.3633	78	-0.2051	0.4443	1.377	-1.2793	128	-0.1953	0.6543	1.4014	-0.0488	178	-0.1563	0.7129	-7.6709	-2.2168
29	-0.1855	-0.0635	1.4111	-1.2598	79	-0.2002	0.2979	1.4111	-0.2588	129	-0.2051	0.5566	-6.3818	-2.1924	179	-0.1709	0.708	1.4014	-1.1572
30	-0.1318	-0.1904	1.4258	-0.3516	80	-0.1953	0.1221	-5.8447	-2.1973	130	-0.21	0.4443	1.3965	-1.04	180	-0.1904	0.6494	1.4111	-0.1904
31	-0.0195	-0.3418	-10	-4.292	81	-0.166	-0.0586	1.4258	-1.1182	131	-0.2051	0.2881	1.3965	-0.2197	181	-0.2051	0.5615	-7.2314	-2.5342
32	0.2441	-0.4688	1.4648	-2.6074	82	-0.1367	-0.1904	1.4209	-0.3076	132	-0.1904	0.1318	-5.5518	-2.002	182	-0.2051	0.4346	1.3916	-1.2744
33	0.542	-0.5713	1.5088	-0.9131	83	0.0098	-0.3418	-10	-4.2627	133	-0.1709	-0.0635	1.4258	-1.084	183	-0.2051	0.2832	1.4014	-0.3174
34	0.5957	-0.6348	1.4893	-0.3223	84	0.2832	-0.4736	1.4551	-2.5977	134	-0.1318	-0.1758	1.4453	-0.2002	184	-0.1904	0.1074	-6.4355	-2.3535
35	1.1426	-0.6445	1.5283	-0.3369	85	0.5127	-0.5811	1.5088	-0.9033	135	0.0293	-0.3467	-10	-4.2627	185	-0.166	-0.0684	1.4209	-1.3086
36	1.9141	-0.6396	1.5332	0.3857	86	0.5908	-0.6348	1.4697	-0.3516	136	0.3369	-0.4688	1.4844	-2.5049	186	-0.1074	-0.1904	1.4502	-0.3271
37	2.2949	-0.6006	1.543	0.5273	87	1.2793	-0.6592	1.665	-0.2734	137	0.5811	-0.5811	1.4941	-0.9424	187	0.0488	-0.3369	1.2061	-0.1514
38	2.5439	-0.5176	1.5576	0.5908	88	1.9678	-0.6445	1.543	0.3809	138	0.6494	-0.6348	-1.8115	-1.4404	188	0.3906	-0.459	1.4746	-0.2734
39	2.4365	-0.3906	0.1172	0.2148	89	2.4268	-0.5957	1.5527	0.5371	139	1.3184	-0.6592	1.5234	-1.0059	189	0.5713	-0.5566	1.46	0.4395
40	2.0605	-0.2539	1.543	0.415	90	2.5635	-0.498	1.5527	0.5859	140	1.9971	-0.6348	1.5674	0.0391	190	0.6689	-0.625	1.5039	0.5322
41	1.4404	-0.1172	1.5674	0.6396	91	2.4316	-0.376	0.1318	0.2246	141	2.5684	-0.5908	1.5332	0.2441	191	1.4648	-0.6396	1.5381	0.1514
42	0.9521	0.0488	-3.125	-0.7617	92	2.1094	-0.2295	1.5381	0.415	142	2.5635	-0.4932	1.582	0.4883	192	2.1289	-0.625	1.5576	0.7275
43	0.2344	0.2393	1.5137	-0.0928	93	1.4355	-0.0977	1.5625	0.6348	143	2.4756	-0.376	-0.2002	-0.0146	193	2.6367	-0.5713	1.543	0.7178
44	-0.0977	0.3809	1.5088	0.3076	94	0.8398	0.0781	-3.3691	-0.8643	144	2.0752	-0.2246	1.5674	0.3418	194	2.5732	-0.4834	1.5674	0.752
45	0.0098	0.5273	-4.3018	-1.2695	95	0.2344	0.2344	1.5283	-0.1611	145	1.416	-0.0977	1.5381	0.5176	195	2.4072	-0.3613	-0.8789	-0.0098
46	-0.1855	0.6201	1.4355	-0.6104	96	-0.0342	0.3857	1.5039	0.2783	146	0.7764	0.0781	-3.9307	-1.0352	196	2.0313	-0.2246	1.5479	0.2832
47	-0.1465	0.6934	1.4355	0.1465	97	0.0586	0.5127	-4.5068	-1.3623	147	0.2295	0.2393	1.4941	-0.3516	197	1.4355	-0.0977	1.5869	0.5762
48	-0.1367	0.7129	-10	-3.584	98	-0.1123	0.6201	1.4453	-0.6641	148	0.0391	0.3906	1.543	0.2539	198	0.7813	0.0684	-5.1709	-1.4258
49	-0.1758	0.7129	1.4355	-1.9434	99	-0.1025	0.6836	1.4404	0.0977	149	-0.0635	0.5127	-5.2295	-1.665	199	0.2148	0.2344	1.5234	-0.5489
50	-0.1953	0.6494	1.3965	-0.6494	100	-0.127	0.7227	-10	-3.6475	150	-0.0879	0.6152	1.4697	-0.7959	200	0.1123	0.376	1.4941	0.1025



Tinggi Gel  
Periode

4 cm  
1.4 dt

No	Load cell (Volt)	Seasim (Volt)	Trimmeter 1 (Volt)	Trimmeter 2 (Volt)	No	Load cell (Volt)	Seasim (Volt)	Trimmeter 1 (Volt)	Trimmeter 2 (Volt)	No	Load cell (Volt)	Seasim (Volt)	Trimmeter 1 (Volt)	Trimmeter 2 (Volt)	No	Load cell (Volt)	Seasim (Volt)	Trimmeter 1 (Volt)	Trimmeter 2 (Volt)
1	0.6592	-0.5322	1.5381	0.2979	51	-0.1953	0.415	1.3867	-1.7529	101	-0.2051	0.7471	1.3428	-0.7471	151	0.0195	-0.0928	1.4746	-0.4053
2	1.1377	-0.6348	1.5186	0.6738	52	-0.1953	0.249	1.4355	-0.5664	102	-0.2148	0.7861	1.3477	0.0244	152	-0.0244	0.0879	1.4795	0.1904
3	1.7432	-0.6885	1.5479	0.7373	53	-0.1514	0.0586	-10	-4.4287	103	-0.2051	0.7861	-10	-3.8135	153	-0.0781	0.249	-10	-4.0137
4	1.9727	-0.7178	1.5234	0.0684	54	-0.0635	-0.1123	1.4258	-2.8223	104	-0.2197	0.752	1.3477	-2.2803	154	-0.1025	0.415	1.4258	-2.3291
5	1.9678	-0.7031	1.3867	0.8203	55	0.2246	-0.2588	1.2891	-0.9863	105	-0.2051	0.6787	1.333	-0.7275	155	-0.1709	0.5469	1.377	-0.791
6	1.7969	-0.6738	1.5186	0.7227	56	0.5908	-0.4053	1.4746	-0.376	106	-0.2051	0.5713	1.3574	-0.1514	156	-0.1758	0.6689	1.3721	-0.1611
7	1.2402	-0.6055	1.5625	0.8057	57	0.6836	-0.5273	1.5137	0.0586	107	-0.2002	0.4248	1.377	-0.3955	157	-0.2002	0.7373	1.3428	-0.4443
8	0.8057	-0.5029	-1.8408	-0.3271	58	1.1621	-0.6299	0.9521	0.0781	108	-0.1855	0.2588	1.3965	0.4883	158	-0.2148	0.791	1.0742	0.4395
9	0.1367	-0.3613	1.5283	0.1709	59	1.8164	-0.6982	1.543	0.3369	109	-0.1367	0.0684	1.4355	0.5371	159	-0.2051	0.791	1.3232	0.498
10	-0.1318	-0.2148	1.499	0.4053	60	1.8799	-0.7129	1.5674	0.4785	110	-0.0098	-0.1074	1.4502	0.6299	160	-0.21	0.7617	1.3672	0.6494
11	0.0439	-0.0781	-4.9854	-1.4355	61	1.8945	-0.708	-3.3008	-0.9326	111	0.3076	-0.2441	-2.1533	-0.5078	161	-0.2051	0.6836	-1.7285	-0.3369
12	-0.1758	0.0977	1.4258	-0.8057	62	1.7285	-0.6738	1.543	-0.3857	112	0.6299	-0.4004	1.4941	0.0049	162	-0.2002	0.5762	1.377	0.1514
13	-0.1611	0.2734	1.4404	0.0635	63	1.1621	-0.6006	1.5527	0.1807	113	0.7422	-0.5273	1.5381	0.3174	163	-0.2051	0.4248	1.3818	0.3662
14	-0.1611	0.4346	-2.9492	-1.2012	64	0.708	-0.4932	-8.2568	-2.6514	114	1.2939	-0.6201	-3.1494	-0.9619	164	-0.1953	0.2686	-2.3486	-0.6396
15	-0.1709	0.5762	1.4111	-0.7617	65	0.1465	-0.3613	1.5137	-1.4111	115	1.8701	-0.6885	1.5332	-0.3906	165	-0.1367	0.0781	1.4063	-0.2295
16	-0.1807	0.6787	1.3574	0.1563	66	-0.1172	-0.21	1.5234	-0.3857	116	2.0947	-0.7031	1.5674	0.1709	166	-0.0195	-0.0977	1.4893	0.332
17	-0.1904	0.752	1.3672	0.4297	67	0.0488	-0.083	-10	-3.9941	117	2.1289	-0.7031	-10	-3.5791	167	0.3271	-0.2393	-9.4238	-2.9346
18	-0.2002	0.791	1.3477	-0.0391	68	-0.166	0.0977	1.4355	-2.5928	118	1.9189	-0.6592	1.5479	-2.1533	168	0.6836	-0.3857	1.5186	-1.5674
19	-0.2051	0.7861	1.3623	0.7568	69	-0.1416	0.2686	0.8154	-0.9424	119	1.2598	-0.5859	1.5283	-0.6592	169	0.8008	-0.5176	1.5088	-0.498
20	-0.2051	0.7471	1.3379	0.708	70	-0.1563	0.4297	1.3916	-0.3076	120	0.8105	-0.4736	1.5283	-0.1123	170	1.4551	-0.6152	-10	-3.8574
21	-0.1953	0.6738	1.4014	0.1709	71	-0.1611	0.5664	1.3916	-0.1172	121	0.1172	-0.3516	1.5137	-0.4736	171	1.9971	-0.6836	1.5234	-2.4121
22	-0.1807	0.5615	1.3525	0.835	72	-0.1855	0.6787	-0.2783	-0.2002	122	-0.0391	-0.2051	1.4258	0.5078	172	2.4023	-0.6982	1.5723	-0.7275
23	-0.1709	0.415	1.416	0.8398	73	-0.1953	0.752	1.3574	0.1904	123	-0.0342	-0.083	1.4502	0.542	173	2.2852	-0.6982	1.5234	-0.2295
24	-0.1367	0.2441	1.416	0.7715	74	-0.21	0.791	1.3623	0.4199	124	-0.1123	0.0928	1.4502	0.6543	174	1.958	-0.6543	1.5869	0.2002
25	0.0732	0.0586	-2.251	-0.3662	75	-0.2051	0.791	-2.0166	-0.5078	125	-0.1123	0.2637	-4.458	-1.1865	175	1.5186	-0.5859	-3.1055	-1.1035
26	0.5469	-0.1172	1.4648	0.0391	76	-0.2051	0.7568	1.3623	-0.0049	126	-0.166	0.4297	1.4014	-0.459	176	0.7861	-0.4736	1.5576	-0.376
27	0.9131	-0.249	1.5479	0.4443	77	-0.2002	0.6787	1.3818	0.3516	127	-0.1758	0.5566	1.3916	0.1514	177	0.293	-0.3584	1.5039	-0.1172
28	1.4697	-0.4053	-3.7988	-1.123	78	-0.2002	0.5664	-2.2314	-0.6445	128	-0.1807	0.6738	-6.1865	-1.9385	178	0.083	-0.2148	-5.3076	-1.7236
29	2.4756	-0.5371	1.5625	-0.4443	79	-0.1758	0.4199	1.4063	-0.127	129	-0.2002	0.7422	1.3574	-1.0059	179	-0.1074	-0.0928	1.4502	-0.9619
30	2.9346	-0.6396	1.5674	0.1367	80	-0.127	0.2539	1.4355	0.3125	130	-0.2148	0.7959	1.3672	-0.0879	180	-0.0439	0.0781	1.4697	-0.0732
31	3.5791	-0.6982	1.5869	0.4199	81	0.0781	0.0635	-8.7842	-2.6904	131	-0.2002	0.7861	-10	-3.335	181	-0.0928	0.2441	1.3867	0.166
32	3.833	-0.7178	1.582	0.5127	82	0.4785	-0.1123	1.4795	-1.4795	132	-0.2148	0.7617	1.3574	-1.8457	182	-0.1221	0.4102	1.4307	-0.1465
33	3.7988	-0.708	0.9521	0.4395	83	0.9131	-0.249	1.5283	-0.3711	133	-0.2051	0.6787	1.377	-0.5957	183	-0.1709	0.542	1.3477	0.6006
34	3.3008	-0.6738	1.582	0.5322	84	1.377	-0.4004	-10	-3.9258	134	-0.2051	0.5762	-10	-3.9063	184	-0.1807	0.6592	1.3867	0.6982
35	2.3877	-0.6006	1.5967	0.7031	85	2.4219	-0.5273	1.6064	-2.3877	135	-0.1807	0.4248	1.416	-2.3145	185	-0.2002	0.7324	1.3428	0
36	1.6357	-0.4883	-7.6074	-2.1387	86	2.8564	-0.625	1.5723	-0.7422	136	-0.1416	0.2686	1.4258	-0.7715	186	-0.2051	0.7813	0.8691	0.7227
37	0.8936	-0.3564	1.5479	-1.1182	87	3.5449	-0.6885	1.5723	-0.1709	137	-0.0049	0.0732	1.4307	-0.2539	187	-0.2051	0.7813	1.3281	0.6787
38	0.1758	-0.2148	1.5137	-0.1807	88	3.7451	-0.7129	1.6211	0.2197	138	0.376	-0.1025	1.3525	0.127	188	-0.21	0.752	1.3965	0.7764
39	-0.1221	-0.083	-10	-4.0625	89	3.7354	-0.708	-4.0332	-1.3281	139	0.8154	-0.2393	0.8643	0.0879	189	-0.2051	0.6738	0.0732	0.2979
40	0.0244	0.0928	1.4893	-2.5439	90	3.2617	-0.6689	1.5918	-0.6543	140	1.123	-0.3906	1.5283	0.376	190	-0.2002	0.5713	1.4014	0.5371
41	-0.1807	0.2637	1.1621	-0.8398	91	2.2998	-0.5957	1.582	0.0586	141	2.1045	-0.5225	1.5527	0.4932	191	-0.1758	0.4248	1.3916	0.5811
42	-0.1807	0.4297	1.3965	-0.2686	92	1.6406	-0.4834	1.543	0.3174	142	2.8223	-0.6152	-3.1641	-0.8447	192	-0.1367	0.2637	-2.168	-0.4492
43	-0.1709	0.5664	1.4014	0.166	93	0.9229	-0.3564	1.543	-0.1416	143	3.2373	-0.6934	1.5674	-0.3809	193	-0.0146	0.083	1.4307	-0.1025
44	-0.1709	0.6836	-0.3467	-0.2002	94	0.166	-0.21	1.499	0.6885	144	3.4863	-0.708	1.6016	0.2539	194	0.376	-0.0928	1.5088	0.4297
45	-0.2051	0.7568	1.3574	0.21	95	-0.1123	-0.0781	1.4697	0.6836	145	3.4521	-0.708	1.5625	0.3906	195	0.8301	-0.2344	-5.7568	-1.748
46	-0.2148	0.8008	1.3379	0.4248	96	0.0146	0.0977	1.4697	0.7227	146	2.8857	-0.6592	1.5967	0.5713	196	1.1768	-0.3906	1.5479	-0.791
47	-0.21	0.8008	-4.8926	-1.3672	97	-0.1758	0.2686	-2.8857	-0.6396	147	2.1631	-0.5908	0.1807	0.1514	197	2.1631	-0.5176	1.5381	-0.083
48	-0.21	0.7617	1.3281	-0.6885	98	-0.1807	0.4297	1.4063	-0.1318	148	1.5576	-0.4736	1.5576	0.415	198	2.8906	-0.625	1.5771	0.2832
49	-0.21	0.6836	1.3672	0.0684	99	-0.1611	0.5615	1.3965	0.3369	149	0.6836	-0.3564	1.5332	0.5518	199	3.1787	-0.6836	1.5674	0.415
50	-0.21	0.5713	-10	-3.2324	100	-0.1904	0.6689	-5.1807	-1.5332	150	0.2344	-0.21	-3.7354	-0.9717	200	3.5547	-0.7031	1.0303	0.3955



Tinggi Gel 4 cm  
 Periode 1.5 dt

No	Load cell (Volt)	Seasim (Volt)	Trimmeter 1 (Volt)	Trimmeter 2 (Volt)	No	Load cell (Volt)	Seasim (Volt)	Trimmeter 1 (Volt)	Trimmeter 2 (Volt)	No	Load cell (Volt)	Seasim (Volt)	Trimmeter 1 (Volt)	Trimmeter 2 (Volt)	No	Load cell (Volt)	Seasim (Volt)	Trimmeter 1 (Volt)	Trimmeter 2 (Volt)
1	0.1611	-0.7178	1.4795	0.5615	51	0.2002	0.1074	1.4209	0.127	101	-0.2344	0.6543	1.2695	-0.2295	151	0.5664	-0.7227	1.5332	0.2246
2	0.0586	-0.6299	1.5186	0.6787	52	0.5859	-0.0781	1.5039	0.0732	102	-0.2246	0.7471	1.2842	0.166	152	0.1123	-0.6396	1.5283	0.4834
3	-0.0439	-0.5225	-3.7012	-0.9814	53	0.6299	-0.2148	1.2646	0.4639	103	-0.2344	0.8057	1.2646	-0.3271	153	-0.0781	-0.5273	-6.1963	-1.8506
4	-0.083	-0.3809	1.582	-0.415	54	0.9961	-0.376	1.5234	0.6006	104	-0.2246	0.835	-1.3623	-0.166	154	-0.083	-0.3955	1.4502	-1.1084
5	-0.1074	-0.2295	1.3965	0.1514	55	1.6553	-0.5176	1.5234	0.6201	105	-0.2148	0.8301	1.2793	0.0635	155	-0.0977	-0.2441	1.4063	-0.1563
6	-0.1221	-0.083	-10	-3.9502	56	1.7822	-0.6299	-2.1045	-0.4443	106	-0.2148	0.7813	1.333	0.5029	156	-0.1611	-0.1025	1.3721	0.1611
7	-0.1904	0.0879	1.3428	-2.4707	57	1.7578	-0.7178	1.5283	-0.1074	107	-0.2197	0.6982	-10	-3.4424	157	-0.2002	0.0732	1.3428	-0.3418
8	-0.2051	0.2686	1.3525	-0.7617	58	1.4453	-0.7715	1.5674	0.3467	108	-0.2393	0.5859	1.3818	-1.9727	158	-0.2197	0.2393	-1.4551	-0.2637
9	-0.2148	0.4248	1.3086	-0.2539	59	0.9619	-0.7813	-9.8047	-3.0566	109	-0.2148	0.4492	1.377	-0.6104	159	-0.2344	0.3955	1.2891	-0.0098
10	-0.2246	0.5664	1.3672	0.2002	60	0.4297	-0.752	1.5332	-1.7236	110	-0.1416	0.2881	1.4111	-0.0684	160	-0.2295	0.5322	1.3232	0.4248
11	-0.2197	0.6787	-5.708	-1.8359	61	0.1367	-0.6934	1.4893	-0.542	111	-0.0146	0.1123	1.4307	0.2002	161	-0.2393	0.6494	-8.4229	-2.5049
12	-0.2295	0.7764	1.3477	-0.9961	62	-0.0146	-0.6104	1.4795	-0.0488	112	0.3125	-0.0684	-1.6113	-0.542	162	-0.2295	0.7373	1.2695	-1.3916
13	-0.2295	0.8203	1.3086	-0.1123	63	-0.083	-0.5029	1.4453	0.1758	113	0.5713	-0.1953	1.4648	-0.1074	163	-0.2344	0.8057	1.2695	-0.3369
14	-0.2197	0.8545	1.3623	0.2734	64	-0.1025	-0.3662	-1.2988	-0.4785	114	0.4443	-0.3564	1.5234	0.3271	164	-0.2295	0.835	-10	-4.2627
15	-0.2246	0.835	1.3477	-0.2393	65	-0.1172	-0.2246	1.3916	-0.1318	115	0.6836	-0.4932	-4.502	-1.4258	165	-0.2393	0.8301	1.2891	-2.7246
16	-0.2051	0.791	1.0889	0.6445	66	-0.1416	-0.0928	1.4209	0.3271	116	1.04	-0.6104	1.5332	-0.625	166	-0.2344	0.7813	0.0537	-1.2354
17	-0.166	0.6982	1.3818	0.6396	67	-0.1904	0.083	-5.8594	-1.8311	117	0.9521	-0.6982	1.5234	-0.0293	167	-0.2246	0.7031	1.3037	-0.5322
18	-0.0781	0.5859	1.4697	0.7764	68	-0.21	0.2539	1.3672	-0.9424	118	0.8447	-0.7568	-8.4619	-2.8076	168	-0.2148	0.5908	1.3867	0.0391
19	0.1855	0.4346	-4.9707	-1.2598	69	-0.2295	0.4102	1.333	-0.1416	119	0.376	-0.7764	1.5088	-1.6113	169	-0.2002	0.4541	-5.2881	-1.7969
20	0.7861	0.2734	1.5137	-0.4492	70	-0.2197	0.5518	1.3428	0.2197	120	0.0391	-0.7617	1.5186	-0.4688	170	-0.1611	0.2881	1.3916	-0.8936
21	1.0889	0.083	1.5186	0.127	71	-0.2246	0.6689	1.3281	-0.0537	121	0.0488	-0.708	1.4502	-0.083	171	-0.0586	0.1123	1.416	-0.1563
22	2.1729	-0.0928	-10	-3.4326	72	-0.2344	0.7568	-1.1328	-0.1318	122	-0.1318	-0.6299	1.4795	-0.4541	172	0.0732	-0.0732	1.416	0.166
23	3.0518	-0.2344	1.5527	-2.2119	73	-0.2344	0.8154	1.3281	0.1465	123	-0.1221	-0.5225	-0.0293	0.0146	173	0.332	-0.2051	1.4551	-0.3076
24	3.6914	-0.3906	1.3623	-0.5518	74	-0.2197	0.8447	1.4063	0.5273	124	-0.1123	-0.3857	1.4258	0.2393	174	0.4199	-0.376	0.7666	0.3857
25	4.2725	-0.5225	1.5723	-0.083	75	-0.2051	0.8252	-4.6973	-1.3086	125	-0.1123	-0.2441	1.4551	0.4541	175	0.2295	-0.5127	1.4795	0.4834
26	4.4971	-0.6299	1.6309	0.332	76	-0.2002	0.7764	1.4453	-0.5225	126	-0.1563	-0.1074	-5.4004	-1.5625	176	0.166	-0.6348	1.5088	0.5762
27	4.2529	-0.7129	-5.6982	-1.7969	77	-0.1514	0.6934	1.416	0.0977	127	-0.2002	0.0684	1.3525	-0.8105	177	0.2246	-0.7227	-1.2451	-0.2734
28	3.5107	-0.7568	1.6162	-0.9668	78	0.0244	0.5762	1.4502	0.4004	128	-0.1953	0.2393	1.3623	-0.0439	178	0.2783	-0.7861	1.5039	0.1074
29	2.3633	-0.7715	1.5625	-0.1074	79	0.4883	0.4346	1.4697	-0.0244	129	-0.2197	0.3955	-10	-4.1553	179	0.0098	-0.7959	1.499	0.3613
30	1.5479	-0.752	1.5625	0.249	80	1.0303	0.2783	1.5283	0.7861	130	-0.2295	0.5371	1.3477	-2.6416	180	-0.0537	-0.7813	-5.332	-1.6455
31	0.6787	-0.7031	1.5234	0.3809	81	1.792	0.1074	1.5186	0.752	131	-0.2295	0.6543	0.083	-1.1963	181	0.0146	-0.7275	1.46	-0.9619
32	0.1123	-0.6152	-0.9326	-0.2393	82	2.8857	-0.0732	1.5918	0.8447	132	-0.2246	0.7471	1.3428	-0.4199	182	-0.0732	-0.6396	1.4453	-0.1123
33	-0.1221	-0.5127	1.4551	0.0293	83	3.4961	-0.21	-3.9795	-0.9131	133	-0.2197	0.8105	1.3477	0.0488	183	-0.0879	-0.5273	1.4111	0.1514
34	-0.0244	-0.376	1.4697	0.4248	84	4.4629	-0.3662	1.6162	-0.3027	134	-0.2295	0.835	-4.0332	-1.3477	184	-0.1221	-0.3906	1.4111	0.3516
35	-0.1416	-0.2295	-10	-3.2666	85	5.0781	-0.5029	1.6113	0.2686	135	-0.2246	0.8301	1.3818	-0.5957	185	-0.1416	-0.2393	-0.6006	-0.1953
36	-0.1855	-0.0879	1.4111	-1.875	86	5.1807	-0.6152	1.6113	0.5127	136	-0.2002	0.7861	1.4307	0.1221	186	-0.1465	-0.0977	1.3623	0.1465
37	-0.2002	0.0928	1.3428	-0.6201	87	4.7314	-0.7031	1.6113	0.0781	137	-0.0928	0.7031	-10	-3.6133	187	-0.1855	0.083	1.3477	0.376
38	-0.2051	0.2686	1.3477	-0.0781	88	3.833	-0.7617	1.626	0.7764	138	0.2002	0.5908	1.4697	-2.1533	188	-0.2002	0.2539	-5.8154	-1.7383
39	-0.2246	0.4297	1.2988	0.1758	89	2.5537	-0.7764	1.5625	0.708	139	0.7666	0.4492	1.4844	-0.6006	189	-0.2197	0.4102	1.3281	-1.0107
40	-0.2344	0.5713	-3.9502	-1.2305	90	1.6113	-0.7568	1.5918	0.7861	140	1.3525	0.2832	1.5283	-0.0293	190	-0.2197	0.5469	1.3135	-0.0781
41	-0.2246	0.6738	1.2793	-0.6641	91	0.7715	-0.7031	-6.1426	-1.6504	141	2.3828	0.1074	1.5527	0.2832	191	-0.2295	0.6592	1.3135	0.2197
42	-0.2246	0.7666	1.3037	0.0928	92	0.0977	-0.6201	1.5283	-0.7959	142	3.208	-0.0732	-2.0264	-0.6104	192	-0.2197	0.752	1.3379	0.4346
43	-0.2344	0.8154	-10	-4.0381	93	-0.0195	-0.5078	1.6113	-0.0439	143	4.5898	-0.2002	1.5967	-0.1172	193	-0.2344	0.8154	-2.2754	-0.5859
44	-0.2148	0.8301	1.3135	-2.5781	94	-0.1416	-0.376	1.4551	0.2539	144	5.459	-0.3662	1.6406	0.3662	194	-0.21	0.8398	1.3721	-0.0635
45	-0.2002	0.8154	-1.2598	-1.5479	95	-0.1318	-0.2295	1.4014	-0.2979	145	5.9131	-0.498	-7.6367	-2.3193	195	-0.2246	0.835	1.4209	0.3613
46	-0.2197	0.7715	1.3477	-0.6738	96	-0.1514	-0.0977	0.5225	0.3809	146	5.9033	-0.6201	1.6406	-1.1963	196	-0.1807	0.791	-5.6396	-1.6602
47	-0.2148	0.6885	1.3477	-0.0586	97	-0.2002	0.0732	1.333	0.4492	147	5.3711	-0.708	1.6406	-0.2246	197	-0.1025	0.7129	1.4355	-0.9033
48	-0.2051	0.5762	-6.0107	-2.0117	98	-0.2148	0.2441	1.3574	0.6006	148	4.3604	-0.7715	1.6309	0.1758	198	0.1953	0.5957	1.4746	0.0244
49	-0.1758	0.4395	1.3867	-1.1133	99	-0.2295	0.4004	-7.6416	-2.1875	149	2.915	-0.791	1.5918	0.3613	199	0.8447	0.4541	1.4795	0.3223
50	-0.0537	0.2832	1.4453	-0.166	100	-0.2295	0.5371	1.3086	-1.2646	150	1.5527	-0.7715	-0.0244	0	200	1.5039	0.2881	1.543	-0.0732



Tinggi Gel 4 cm  
Periode 1.6 dt

No	Load cell (Volt)	Seasim (Volt)	Trimmeter 1 (Volt)	Trimmeter 2 (Volt)	No	Load cell (Volt)	Seasim (Volt)	Trimmeter 1 (Volt)	Trimmeter 2 (Volt)	No	Load cell (Volt)	Seasim (Volt)	Trimmeter 1 (Volt)	Trimmeter 2 (Volt)	No	Load cell (Volt)	Seasim (Volt)	Trimmeter 1 (Volt)	Trimmeter 2 (Volt)
1	-0.2197	0.8203	1.2939	0.5518	51	0.5908	-0.8594	1.5479	0.6055	101	0.1758	0.9131	1.46	0.3564	151	-0.1563	-0.6982	1.3672	0.1367
2	-0.2246	0.9033	1.2842	0.5859	52	0.0098	-0.874	1.4844	0.0293	102	0.8008	0.835	1.5039	0.5273	152	-0.1611	-0.5811	-2.6758	-0.9766
3	-0.2246	0.9473	1.3232	0.7227	53	0.0049	-0.8496	1.2402	0.6494	103	1.626	0.752	0.3662	0.332	153	-0.1855	-0.4346	1.3232	-0.5566
4	-0.21	0.9521	-2.8467	-0.6055	54	-0.1318	-0.8008	1.4014	0.5371	104	2.793	0.6201	1.5576	0.4785	154	-0.2002	-0.2783	1.3037	0.0586
5	-0.2051	0.9229	1.3721	-0.0537	55	-0.1025	-0.6982	1.4453	0.6889	105	4.0674	0.4785	1.626	0.752	155	-0.2295	-0.1221	1.2891	0.2539
6	-0.1855	0.8594	1.3818	0.3857	56	-0.166	-0.5908	-6.3281	-1.8018	106	5.5371	0.3076	-8.7256	-2.373	156	-0.21	0.0635	1.3037	0.3955
7	-0.1318	0.7715	-9.7852	-2.8711	57	-0.1904	-0.4443	1.3574	-1.1035	107	6.8994	0.1416	1.6553	-1.2256	157	-0.2246	0.2539	-3.8965	-1.1328
8	0.0439	0.6445	1.4355	-1.8408	58	-0.2197	-0.293	1.2646	-0.1904	108	7.7295	-0.0586	1.665	-0.1172	158	-0.2197	0.4297	1.3135	-0.6201
9	0.4541	0.4932	1.4551	-0.3076	59	-0.2295	-0.1367	1.3037	0.1563	109	7.9004	-0.1953	1.6602	0.3125	159	-0.2344	0.5957	1.3037	0.1172
10	0.8203	0.3271	1.4795	0.0781	60	-0.2246	0.0439	1.2451	0.2832	110	7.4902	-0.3711	1.6602	0.498	160	-0.2197	0.7324	1.3232	0.3418
11	0.9961	0.1465	1.543	0.4248	61	-0.2295	0.2393	-2.5732	-0.7568	111	6.3428	-0.498	0.0244	0.1367	161	-0.2295	0.8496	1.3525	0.5225
12	1.7529	-0.0488	-2.4902	-0.7275	62	-0.2295	0.4053	1.2109	-0.3418	112	4.6338	-0.6396	1.626	0.3613	162	-0.2197	0.9326	-1.6113	-0.3223
13	2.2363	-0.2002	1.5723	-0.2393	63	-0.2246	0.5664	1.2598	0.249	113	2.8223	-0.7324	1.626	0.5957	163	-0.2002	0.9668	1.3965	0.0928
14	2.4609	-0.376	1.5527	0.2734	64	-0.2246	0.6934	-10	-3.1689	114	1.4355	-0.835	-10	-3.2813	164	-0.0537	0.9717	1.4551	0.5029
15	2.3047	-0.5176	1.5625	0.5029	65	-0.2344	0.8057	1.2744	-1.8311	115	0.4932	-0.8594	1.5479	-2.0459	165	0.3711	0.9326	-10	-3.3447
16	1.8896	-0.6494	1.543	0.5518	66	-0.2295	0.8838	1.2354	-0.5566	116	-0.0293	-0.8838	1.499	-0.5859	166	1.377	0.8594	1.499	-1.9092
17	1.3281	-0.752	-3.5986	-0.9473	67	-0.21	0.9326	1.2939	-0.0195	117	0.0732	-0.8496	1.46	-0.1123	167	2.4316	0.7568	1.5381	-0.4297
18	0.5469	-0.835	1.5088	-0.459	68	-0.2051	0.9375	1.2744	0.2344	118	-0.1221	-0.8057	1.4404	0.1514	168	3.6572	0.6201	1.5625	0.0977
19	0.1953	-0.8691	1.5381	0.166	69	-0.2246	0.9082	-3.7939	-1.123	119	-0.1025	-0.6982	-5.5127	-1.8164	169	5.6348	0.4639	1.626	0.4541
20	-0.0684	-0.874	-10	-3.8232	70	-0.21	0.8447	1.333	-0.5371	120	-0.1514	-0.5908	1.3379	-1.1523	170	7.4756	0.293	-3.1689	-0.8301
21	0.0537	-0.8545	1.4746	-2.4854	71	-0.1807	0.7568	1.4111	0.2246	121	-0.2246	-0.4346	1.3037	-0.21	171	8.8525	0.1123	1.6455	-0.2002
22	-0.1318	-0.8105	-0.1367	-1.2598	72	-0.127	0.625	-10	-3.4424	122	-0.2246	-0.2881	1.2939	0.0439	172	9.4678	-0.0781	1.6846	0.3613
23	-0.1465	-0.7129	1.4258	-0.5273	73	-0.0293	0.4834	1.4502	-2.1582	123	-0.2344	-0.127	1.2646	0.2734	173	9.5654	-0.2197	1.6553	0.5615
24	-0.1416	-0.6006	1.3916	-0.0732	74	0.2783	0.3125	0.6006	-0.8301	124	-0.2197	0.0537	-3.0811	-1.001	174	9.0527	-0.3906	1.6943	0.6836
25	-0.1563	-0.4541	-6.1914	-2.124	75	0.5859	0.1416	1.4941	-0.166	125	-0.2197	0.2539	1.1963	-0.5518	175	7.8125	-0.5322	1.4404	0.6494
26	-0.1904	-0.3076	1.3184	-1.3525	76	0.4688	-0.0537	1.5381	0.1807	126	-0.2246	0.4199	1.1816	0.0586	176	5.8887	-0.6641	1.6455	0.7031
27	-0.2002	-0.1416	1.333	-0.2686	77	0.625	-0.1904	-3.1934	-1.0303	127	-0.2246	0.5859	1.1865	0.2881	177	3.6719	-0.7715	1.6162	0.7471
28	-0.2197	0.0439	1.2891	0.0098	78	0.8643	-0.3662	1.5039	-0.4541	128	-0.2197	0.7129	1.1865	0.4102	178	1.7822	-0.8594	-7.7295	-2.1338
29	-0.2246	0.2344	1.3379	0.332	79	0.8057	-0.5078	1.5527	0.1465	129	-0.2344	0.8301	-5.7129	-1.6309	179	0.5225	-0.8838	1.5283	-1.3037
30	-0.2295	0.4102	-8.2715	-2.5488	80	0.6738	-0.6396	-9.2041	-2.998	130	-0.2197	0.8984	1.2012	-1.001	180	0.0049	-0.8887	1.5039	-0.2246
31	-0.2246	0.5762	1.333	-1.5869	81	0.4004	-0.7324	1.5332	-1.7041	131	-0.2148	0.9521	1.2207	-0.0293	181	-0.0195	-0.8643	1.5674	0.1074
32	-0.2246	0.7129	0.7031	-0.5029	82	0.1123	-0.8252	1.4941	-0.5566	132	-0.2197	0.9521	1.2256	0.2197	182	-0.1416	-0.8105	1.4258	0.3076
33	-0.2246	0.8252	1.3428	0.0244	83	-0.0879	-0.8594	1.5234	-0.0586	133	-0.2344	0.9277	1.2744	-0.2295	183	-0.1172	-0.7031	-3.3301	-1.0889
34	-0.2344	0.8984	1.3428	0.3027	84	0	-0.8789	1.4551	0.1465	134	-0.2197	0.8594	-1.6162	-0.2441	184	-0.1709	-0.5859	1.3379	-0.6348
35	-0.2197	0.9375	-4.1357	-1.1816	85	-0.1074	-0.8496	-2.9346	-1.0254	135	-0.1709	0.7666	1.3232	0.0488	185	-0.2051	-0.4395	1.2891	0.0146
36	-0.1758	0.9326	1.3867	-0.5811	86	-0.1074	-0.8008	1.4063	-0.6055	136	-0.1758	0.6348	1.3525	0.4639	186	-0.2148	-0.2734	-9.5898	-3.2471
37	-0.1074	0.9131	1.4648	0.1904	87	-0.1074	-0.6934	1.4258	0.0684	137	-0.1367	0.4883	-9.7266	-2.8564	187	-0.2246	-0.1172	1.25	-2.2607
38	0.1563	0.8398	1.4258	0.3906	88	-0.1318	-0.5908	-10	-4.0527	138	-0.0635	0.3125	1.4014	-1.7188	188	-0.2197	0.0732	-2.7393	-1.8115
39	0.7764	0.752	1.5332	0.0195	89	-0.1807	-0.4443	1.377	-2.5146	139	0.0928	0.1367	1.4209	-0.4248	189	-0.2295	0.2734	1.1816	-1.0645
40	1.4258	0.6299	0.9619	0.6348	90	-0.1904	-0.293	0.8887	-1.0498	140	0.3174	-0.0635	1.4258	-0.0293	190	-0.2295	0.459	1.1768	-0.1807
41	2.5488	0.4834	1.5771	0.7666	91	-0.2148	-0.1318	1.3379	-0.3955	141	0.2979	-0.2051	1.46	0.2881	191	-0.2295	0.6201	-10	-4.2334
42	3.6816	0.3174	1.582	0.8447	92	-0.2197	0.0391	1.3232	0.0098	142	0.1563	-0.376	-7.5586	-2.373	192	-0.2246	0.7568	1.167	-2.7539
43	4.5703	0.1465	-9.3799	-2.4512	93	-0.2197	0.2393	-10	-3.5156	143	-0.0244	-0.5176	1.4502	-1.4746	193	-0.2344	0.874	-0.8496	-1.5088
44	5.3955	-0.0537	1.6016	-1.4014	94	-0.2197	0.4053	1.3135	-2.3633	144	-0.0781	-0.6494	1.4502	-0.3369	194	-0.2295	0.9424	1.1768	-0.7373
45	5.835	-0.1953	1.6699	-0.1221	95	-0.2197	0.5713	-0.1221	-1.0547	145	0.0537	-0.7568	1.4453	0.0293	195	-0.2295	0.9814	1.1963	-0.0879
46	5.7227	-0.3662	1.6016	0.1953	96	-0.21	0.6982	1.3232	-0.4297	146	-0.1221	-0.8496	1.4551	0.2588	196	-0.2246	0.9717	-10	-4.1016
47	5.0439	-0.5078	1.6748	0.498	97	-0.2148	0.8154	1.416	0.1514	147	-0.0928	-0.874	-9.0283	-2.8516	197	-0.2295	0.9326	1.2354	-2.5439
48	3.9697	-0.6396	0.3125	0.1416	98	-0.2197	0.8838	-5.0244	-1.6455	148	-0.0977	-0.8838	1.4111	-1.8262	198	-0.2197	0.8545	1.2012	-0.8594
49	2.6025	-0.7373	1.6162	0.3564	99	-0.1953	0.9375	1.4404	-0.7959	149	-0.1318	-0.8594	1.3818	-0.5273	199	-0.2246	0.752	1.2793	-0.2979
50	1.4941	-0.835	1.5527	0.4932	100	-0.1123	0.9277	1.4258	-0.0098	150	-0.1123	-0.8057	1.3721	-0.1367	200	-0.21	0.6152	1.3232	0.127



Tinggi Gel  
Periode

4 cm  
1.7 dt

No	Load cell (Volt)	Seasim (Volt)	Trimmetr 1 (Volt)	Trimmetr 2 (Volt)	No	Load cell (Volt)	Seasim (Volt)	Trimmetr 1 (Volt)	Trimmetr 2 (Volt)	No	Load cell (Volt)	Seasim (Volt)	Trimmetr 1 (Volt)	Trimmetr 2 (Volt)	No	Load cell (Volt)	Seasim (Volt)	Trimmetr 1 (Volt)	Trimmetr 2 (Volt)
1	-0.249	-0.7471	-5.3076	-1.543	51	-0.3711	0.7422	1.1572	-2.2266	101	2.5732	-0.5469	1.5674	0.5322	151	-0.3711	0.3857	0.2637	-0.7715
2	-0.293	-0.8252	1.3818	-0.8154	52	-0.3809	0.8691	0.9229	-0.8154	102	1.1572	-0.6641	1.5625	0.5811	152	-0.3711	0.5615	1.3086	-0.2979
3	-0.3027	-0.8887	1.3623	-0.1318	53	-0.3711	0.9619	1.1816	-0.293	103	0.1025	-0.7715	-0.7764	-0.1025	153	-0.3662	0.7178	1.3818	0.249
4	-0.3223	-0.8936	1.3428	0.1514	54	-0.3809	1.0303	1.2305	0.1514	104	-0.2783	-0.8545	1.4795	0.0781	154	-0.3516	0.8496	-7.9639	-2.4658
5	-0.3174	-0.8936	1.3281	0.2637	55	-0.3711	1.0547	-7.1826	-2.2607	105	-0.1611	-0.9082	1.4453	0.3711	155	-0.2881	0.9473	1.4258	-1.4209
6	-0.3369	-0.8545	-4.3213	-1.377	56	-0.3955	1.0498	1.2695	-1.3135	106	-0.2881	-0.918	-10	-3.833	156	-0.166	1.0205	1.416	-0.2441
7	-0.3418	-0.7959	1.2891	-0.8838	57	-0.3613	1.001	1.2842	-0.2393	107	-0.293	-0.9131	1.3672	-2.5781	157	0.3857	1.0498	1.4795	0.2295
8	-0.3613	-0.6787	1.2793	-0.0781	58	-0.3662	0.918	1.333	0.1367	108	-0.3125	-0.8789	-1.5674	-1.7139	158	1.3232	1.04	1.5039	0.4834
9	-0.3613	-0.5762	1.2598	0.1074	59	-0.3125	0.8008	1.3721	0.3906	109	-0.3662	-0.8203	1.2939	-0.9277	159	2.4707	0.9863	-3.9209	-0.9961
10	-0.3809	-0.4297	1.2695	-0.3613	60	-0.2539	0.6592	-3.2373	-0.9131	110	-0.3662	-0.7031	1.25	-0.2588	160	3.96	0.9082	1.5625	-0.4883
11	-0.3662	-0.2881	-1.001	-0.1953	61	-0.1221	0.4834	1.4014	-0.4102	111	-0.3711	-0.5908	-10	-4.3115	161	5.5322	0.791	1.626	0.3906
12	-0.376	-0.127	1.2646	0.1074	62	0.0293	0.3027	1.4355	0.1953	112	-0.376	-0.4492	1.1865	-2.9199	162	6.748	0.6494	1.6162	0.5859
13	-0.3711	0.0391	1.3037	0.3613	63	0.1758	0.1074	1.4258	0.3809	113	-0.376	-0.2979	-2.4365	-2.124	163	7.8174	0.4883	1.6699	0.7959
14	-0.3809	0.2393	-8.4668	-2.5146	64	0.0732	-0.0928	1.4404	0.5127	114	-0.376	-0.1416	1.1475	-1.2109	164	8.2031	0.3125	0.0781	0.332
15	-0.3662	0.4102	1.2939	-1.6699	65	-0.1025	-0.2441	-5.6006	-1.6211	115	-0.3809	0.0342	1.2061	-0.376	165	8.0176	0.127	1.665	0.5957
16	-0.3711	0.5811	0.4004	-0.5615	66	-0.2441	-0.4102	1.4551	-1.0498	116	-0.3809	0.2246	-7.7051	-2.8125	166	7.3584	-0.0684	1.6553	0.7373
17	-0.3711	0.7227	1.3379	-0.0928	67	-0.2588	-0.5518	1.3965	-0.083	117	-0.376	0.4102	1.1523	-1.6455	167	5.9326	-0.2148	-7.6563	-2.0361
18	-0.3564	0.8545	1.4014	0.332	68	-0.2637	-0.6641	1.416	0.1563	118	-0.376	0.5811	1.1426	-0.5664	168	4.0137	-0.3809	1.6064	-1.2549
19	-0.3027	0.9424	-5.8301	-1.7529	69	-0.2637	-0.7715	1.4258	0.3613	119	-0.376	0.7275	-10	-4.3848	169	2.3242	-0.5273	1.6162	-0.0732
20	-0.1807	1.0156	1.4355	-0.9863	70	-0.2637	-0.8545	-8.0664	-2.4951	120	-0.3857	0.8545	1.1768	-2.3242	170	1.0352	-0.6494	1.5332	0.1807
21	0.4102	1.0352	1.4746	0.0439	71	-0.2783	-0.9082	1.3916	-1.5186	121	-0.3857	0.9473	-3.7158	-2.5537	171	0.0146	-0.752	1.5381	0.4248
22	1.4404	1.0352	1.5039	0.415	72	-0.3076	-0.9131	1.3574	-0.4541	122	-0.3857	1.0156	1.2207	-1.4453	172	-0.2734	-0.8496	-7.4561	-2.3047
23	2.6563	0.9863	1.5527	0.6299	73	-0.3076	-0.9131	1.3281	-0.0928	123	-0.3809	1.04	1.2646	-0.3662	173	-0.1855	-0.9082	1.4502	-1.5186
24	4.1113	0.9131	-4.0869	-0.9521	74	-0.3174	-0.874	1.3135	0.1465	124	-0.3711	1.0303	-10	-4.3066	174	-0.293	-0.9229	1.3721	-0.3613
25	5.6104	0.8008	1.6162	-0.3271	75	-0.3369	-0.8057	-7.71	-2.5195	125	-0.3467	0.9814	1.3281	-2.0898	175	-0.3125	-0.9229	1.3672	-0.0049
26	7.168	0.6689	1.6602	0.4102	76	-0.3662	-0.7031	1.2939	-1.6504	126	-0.332	0.8984	-1.2695	-1.8115	176	-0.3223	-0.8887	1.3184	0.1709
27	8.335	0.498	1.685	0.6299	77	-0.3564	-0.5811	1.2549	-0.4639	127	-0.3027	0.7764	1.3867	-0.8057	177	-0.3467	-0.8203	-7.8125	-2.5049
28	8.9795	0.3174	1.6699	0.791	78	-0.3711	-0.4395	1.2598	-0.0977	128	-0.2148	0.6396	1.4014	-0.166	178	-0.3662	-0.7178	1.2354	-1.6309
29	8.8818	0.1172	0.2441	0.3857	79	-0.3711	-0.2832	1.2695	0.166	129	-0.0391	0.4736	-9.9902	-3.3252	179	-0.376	-0.6055	1.1475	-0.498
30	8.0518	-0.0781	1.6748	0.5957	80	-0.3809	-0.1318	-3.1104	-1.0596	130	0.166	0.2979	1.4307	-2.2363	180	-0.3711	-0.4639	1.3086	-0.1758
31	6.4941	-0.2393	1.665	0.7275	81	-0.376	0.0488	1.2744	-0.5225	131	0.1709	0.1123	-0.0293	-0.9912	181	-0.3809	-0.3076	1.1914	0.1611
32	4.624	-0.4004	-8.5352	-2.3291	82	-0.3809	0.2441	1.2891	0.1172	132	0.0586	-0.0781	1.4355	-0.4541	182	-0.3809	-0.1514	-7.4805	-2.4414
33	2.6563	-0.542	1.5869	-1.5674	83	-0.3711	0.4248	1.2939	0.3223	133	-0.1709	-0.2344	1.4746	0.0977	183	-0.3857	0.0195	1.167	-1.4355
34	1.3086	-0.6592	0.7764	-0.415	84	-0.3711	0.6006	1.333	0.4736	134	-0.249	-0.3955	1.4404	0.2539	184	-0.3809	0.2051	1.1328	-0.4541
35	0.1465	-0.7617	1.5088	-0.0244	85	-0.3564	0.7471	-2.5342	-0.6348	135	-0.127	-0.5371	1.4648	0.415	185	-0.3809	0.3955	-10	-4.3457
36	-0.2637	-0.8447	1.4893	0.2783	86	-0.376	0.8691	1.3672	-0.127	136	-0.2734	-0.6592	-2.2803	-0.7227	186	-0.3809	0.5615	1.0352	-2.9053
37	-0.1611	-0.8984	-10	-3.3447	87	-0.3223	0.9668	1.4111	0.3857	137	-0.2344	-0.7568	1.4307	-0.3564	187	-0.3809	0.7178	-0.6738	-1.5283
38	-0.3027	-0.9082	1.4063	-2.1191	88	-0.1611	1.0303	-10	-3.6475	138	-0.2588	-0.8447	1.4063	0.1318	188	-0.3857	0.8447	1.167	-0.8301
39	-0.3125	-0.9082	1.1133	-0.7715	89	0.3955	1.0645	1.4844	-2.2607	139	-0.2686	-0.9033	1.1572	0.1318	189	-0.3857	0.9473	1.2207	-0.0684
40	-0.332	-0.874	1.3037	-0.3271	90	1.4063	1.0547	1.4111	-0.5273	140	-0.2686	-0.9229	1.3623	-0.4053	190	-0.3809	1.0107	-10	-3.8867
41	-0.3467	-0.8154	1.3086	0.0488	91	2.5635	0.9961	1.543	0.0635	141	-0.2881	-0.9131	-0.249	0.0146	191	-0.3809	1.0449	1.2891	-2.373
42	-0.376	-0.708	-8.6621	-2.8613	92	4.0039	0.918	1.5869	0.4541	142	-0.3271	-0.8789	1.3135	0.0537	192	-0.376	1.0352	0.3076	-1.0547
43	-0.3662	-0.5908	1.2207	-2.002	93	5.2148	0.8008	-8.8379	-2.5244	143	-0.3271	-0.8057	1.3135	0.4053	193	-0.3711	0.9863	1.3281	-0.3613
44	-0.3809	-0.4443	-0.5078	-1.0791	94	6.9727	0.6494	1.6406	-1.3867	144	-0.3564	-0.7031	1.1279	0.332	194	-0.3467	0.9033	1.3672	0.1074
45	-0.376	-0.2881	1.1523	-0.5322	95	8.0127	0.4785	1.6699	-0.1221	145	-0.3662	-0.5908	1.2939	-0.2295	195	-0.2832	0.7861	-6.5186	-2.0654
46	-0.3857	-0.127	1.1523	-0.0586	96	8.5547	0.2979	1.6553	0.2832	146	-0.376	-0.4492	-1.4453	-0.2686	196	-0.1807	0.6445	1.4307	-1.2451
47	-0.376	0.0537	-5.4346	-1.9141	97	8.4375	0.0977	1.6699	0.5615	147	-0.3711	-0.3027	1.2793	0.0293	197	0.0391	0.4785	1.4404	-0.1416
48	-0.376	0.249	1.1377	-1.0693	98	7.5928	-0.0928	-1.9775	-0.4492	148	-0.3809	-0.1563	1.2695	0.3223	198	0.2539	0.2979	1.4258	0.1416
49	-0.376	0.4297	1.1279	-0.2246	99	6.2744	-0.2441	1.6699	0.0244	149	-0.3857	0.0146	-9.6582	-2.9297	199	0.1807	0.1123	1.4844	0.4248
50	-0.3857	0.6006	-10	-3.6133	100	4.3311	-0.4102	1.6309	0.3955	150	-0.3711	0.2051	1.2744	-1.9385	200	-0.1611	-0.083	-7.8369	-2.3828



tinggi Gel 4 cm  
 Periode 1.8 dt

No	Load cell (Volt)	Seasim (Volt)	Trimmeter 1 (Volt)	Trimmeter 2 (Volt)	No	Load cell (Volt)	Seasim (Volt)	Trimmeter 1 (Volt)	Trimmeter 2 (Volt)	No	Load cell (Volt)	Seasim (Volt)	Trimmeter 1 (Volt)	Trimmeter 2 (Volt)	No	Load cell (Volt)	Seasim (Volt)	Trimmeter 1 (Volt)	Trimmeter 2 (Volt)	No	Load cell (Volt)	Seasim (Volt)	Trimmeter 1 (Volt)	Trimmeter 2 (Volt)
1	9.3701	0.4492	0.4102	0.4199	51	-0.2637	-0.8252	1.2793	-2.7295	101	-0.2686	0.9863	1.1523	0.0098	151	-0.1465	-0.5615	-8.75	-2.6318					
2	7.8584	0.2832	1.6602	0.5469	52	-0.2686	-0.7422	-0.1514	-1.3867	102	-0.2637	1.0059	1.1963	0.293	152	-0.1172	-0.6396	1.4551	-1.7969					
3	5.5029	0.1025	1.6748	0.791	53	-0.2734	-0.6445	1.2695	-0.6738	103	-0.2588	0.9961	-6.084	-1.8359	153	-0.2148	-0.7422	0.4346	-0.708					
4	3.2617	-0.0781	1.5869	0.7666	54	-0.2734	-0.5322	1.2695	-0.1807	104	-0.2539	0.9717	1.2646	-1.0205	154	-0.166	-0.7959	1.3672	-0.249					
5	1.5967	-0.2295	1.582	0.8203	55	-0.2783	-0.3906	-7.3193	-2.5586	105	-0.2588	0.9082	1.2891	-0.1172	155	-0.2246	-0.874	1.3379	0.0928					
6	0.2637	-0.3857	-1.0449	-0.0635	56	-0.2832	-0.2295	1.2793	-1.6455	106	-0.2588	0.8301	1.3135	0.2148	156	-0.2539	-0.8887	-10	-4.0723					
7	-0.1855	-0.5127	1.4941	0.166	57	-0.2686	-0.0732	1.1621	-0.4785	107	-0.21	0.7129	1.3525	0.4199	157	-0.2734	-0.9033	1.2256	-2.8076					
8	-0.0439	-0.6299	1.4307	0.4053	58	-0.2734	0.127	1.3037	-0.1123	108	-0.1611	0.5811	-4.4531	-1.2646	158	-0.2881	-0.8594	-2.5293	-2.0996					
9	-0.2148	-0.7178	1.4063	0.5078	59	-0.2783	0.3076	1.3525	0.2637	109	-0.0781	0.4199	1.3818	-0.6348	159	-0.2783	-0.8154	1.1475	-1.2695					
10	-0.2002	-0.7959	1.333	0.4834	60	-0.2783	0.4785	-8.5547	-2.6416	110	-0.0244	0.249	1.4063	0.0732	160	-0.2832	-0.7178	1.1377	-0.4395					
11	-0.2393	-0.8643	-3.7109	-1.0498	61	-0.2539	0.625	1.4014	-1.582	111	-0.0049	0.0586	1.3867	0.2783	161	-0.2881	-0.625	-10	-4.4922					
12	-0.2637	-0.8936	1.2451	-0.6738	62	-0.1074	0.7568	1.3525	-0.3418	112	-0.0439	-0.1172	1.46	0.1855	162	-0.2881	-0.4932	1.084	-2.9883					
13	-0.2637	-0.8936	1.2061	-0.0098	63	0.3711	0.8594	1.4697	0.1318	113	-0.0977	-0.2734	-0.5762	-0.0684	163	-0.2881	-0.3564	-0.8936	-1.7676					
14	-0.2832	-0.874	1.1572	0.0977	64	1.3379	0.9375	1.5381	0.4639	114	-0.1416	-0.4248	1.3867	0.1758	164	-0.2881	-0.1855	1.0986	-0.8789					
15	-0.2783	-0.8203	1.1523	0.2539	65	2.6953	0.9912	-6.8994	-1.9287	115	-0.1758	-0.5469	1.3916	0.3955	165	-0.2734	-0.0244	1.0498	-1.0547					
16	-0.2832	-0.7422	-4.8877	-1.6064	66	4.1699	1.0156	1.582	-1.1084	116	-0.2002	-0.6396	-8.1689	-2.4707	166	-0.2783	0.1758	-2.7979	-1.1035					
17	-0.2881	-0.6445	1.084	-0.9668	67	6.4453	1.0107	1.6406	0.1318	117	-0.21	-0.7324	1.3477	-1.6553	167	-0.2686	0.3467	1.0449	-0.6055					
18	-0.2686	-0.542	1.04	-0.2295	68	8.4863	0.9766	1.6455	0.498	118	-0.2295	-0.8008	0.6494	-0.6152	168	-0.293	0.5225	1.0791	-0.0098					
19	-0.2783	-0.415	-10	-3.5158	69	9.9951	0.918	1.6992	0.7666	119	-0.2393	-0.8643	1.3086	-0.3027	169	-0.2881	0.6543	-10	-3.6035					
20	-0.2832	-0.2539	1.0205	-2.2168	70	9.9951	0.8301	-8.335	-2.168	120	-0.249	-0.8936	1.3037	0.1367	170	-0.2832	0.7861	1.1182	-2.29					
21	-0.2832	-0.0977	1.0156	-0.8496	71	9.9951	0.7129	1.7139	-0.7568	121	-0.2539	-0.9033	-10	-4.1113	171	-0.2637	0.874	0.4443	-0.9668					
22	-0.2832	0.0977	-10	-4.668	72	9.9951	0.5762	0.0684	-0.542	122	-0.2686	-0.874	1.2744	-2.7246	172	-0.2686	0.957	1.167	-0.3174					
23	-0.2686	0.293	1.04	-2.9541	73	9.9951	0.415	1.6992	-0.083	123	-0.2734	-0.8154	-0.0537	-1.3574	173	-0.2783	0.9912	1.1719	0.0439					
24	-0.293	0.459	0.5029	-1.3477	74	8.2813	0.249	1.6895	0.4541	124	-0.2783	-0.7275	1.25	-0.6592	174	-0.3027	1.0156	-9.0527	-2.8516					
25	-0.293	0.6201	-8.4375	-3.6426	75	6.0938	0.0684	1.6455	0.6104	125	-0.2783	-0.6299	1.25	-0.1904	175	-0.3027	0.9961	1.2646	-1.7725					
26	-0.2783	0.7568	1.0449	-2.5439	76	3.7158	-0.1123	1.6211	0.6982	126	-0.2783	-0.5029	-7.2705	-2.5439	176	-0.3027	0.9717	1.123	-0.4688					
27	-0.2686	0.8643	-4.0967	-2.3486	77	1.6895	-0.2588	-3.3496	-0.8008	127	-0.2783	-0.3862	1.25	-1.5918	177	-0.2588	0.8984	1.3037	-0.0879					
28	-0.2832	0.9424	1.1035	-1.3477	78	0.5859	-0.4004	1.5332	-0.3857	128	-0.2832	-0.2002	1.2598	-0.4688	178	-0.2148	0.8154	1.3867	0.3369					
29	-0.2783	0.9961	1.1572	-0.3418	79	-0.1709	-0.5322	1.499	0.21	129	-0.2881	-0.0391	1.2744	-0.1025	179	-0.1611	0.6934	-6.626	-2.0361					
30	-0.2832	1.0156	-10	-4.2969	80	-0.0928	-0.6348	1.4307	0.3467	130	-0.2637	0.1563	1.3037	0.21	180	-0.0977	0.5566	1.4111	-1.123					
31	-0.2783	1.0107	1.2354	-2.749	81	-0.2197	-0.7227	1.4063	0.4443	131	-0.2686	0.3271	-6.1768	-1.9727	181	0.0391	0.3857	1.3916	-0.1953					
32	-0.2783	0.9814	-1.7676	-1.8066	82	-0.1563	-0.8008	-5.1904	-1.5625	132	-0.2783	0.4932	1.3477	-1.1279	182	0.1318	0.2148	1.4258	0.1855					
33	-0.2441	0.9277	1.2891	-0.918	83	-0.21	-0.8594	1.3086	-1.0547	133	-0.2539	0.6299	1.377	-0.1563	183	0.0293	0.0098	1.4258	0.3516					
34	-0.2637	0.8398	1.3086	-0.1953	84	-0.2637	-0.8887	1.2402	-0.1758	134	-0.1953	0.7617	1.4014	0.2295	184	-0.1074	-0.1514	-8.7891	-2.6465					
35	-0.2197	0.7373	1.3379	0.166	85	-0.2734	-0.8887	1.2109	0.0146	135	0.0146	0.8496	1.4502	0.4492	185	-0.1758	-0.3125	1.4063	-1.8115					
36	-0.1807	0.6006	1.377	-0.0684	86	-0.2832	-0.8594	1.167	0.2051	136	0.7227	0.9375	-3.8916	-1.0254	186	-0.1953	-0.4492	0.874	-0.5469					
37	-0.0879	0.4492	-0.4102	0.0391	87	-0.2783	-0.8008	-7.1973	-2.3242	137	1.7871	0.9766	1.5137	-0.4297	187	-0.1904	-0.5762	1.377	-0.1758					
38	0	0.2783	1.3916	0.2246	88	-0.2881	-0.7178	1.1035	-1.582	138	3.3545	1.0059	1.5723	0.3369	188	-0.2051	-0.6543	1.416	0.1855					
39	0.0684	0.0977	1.416	0.5176	89	-0.2832	-0.625	0.5762	-0.6348	139	4.7217	0.9863	1.5869	0.5762	189	-0.1904	-0.752	-6.3525	-2.1289					
40	0	-0.0879	-10	-3.5059	90	-0.2979	-0.5127	1.0498	-0.2539	140	6.9434	0.9668	1.6504	0.8105	190	-0.2197	-0.8203	1.3574	-1.377					
41	-0.1074	-0.2344	1.416	-2.3047	91	-0.2734	-0.3711	1.0498	-0.6641	141	8.6328	0.8936	-2.002	-0.2393	191	-0.2393	-0.8887	0.8154	-0.5078					
42	-0.1709	-0.3906	0.1953	-1.0254	92	-0.293	-0.2051	-1.2305	-0.4297	142	9.8486	0.8154	1.6846	0.1318	192	-0.2441	-0.9131	1.3135	-0.1563					
43	-0.1904	-0.5225	1.3965	-0.4004	93	-0.2832	-0.0391	1.0303	-0.1172	143	9.9951	0.6885	1.6992	0.6592	193	-0.249	-0.9229	1.2646	0.1221					
44	-0.1807	-0.625	1.4014	0.0098	94	-0.2881	0.1563	1.0254	-0.5176	144	9.9951	0.5615	1.6846	0.8398	194	-0.2637	-0.8887	-10	-3.2666					
45	-0.2002	-0.7178	-6.9824	-2.3584	95	-0.2686	0.3418	-2.5679	-0.7275	145	9.5361	0.3906	1.7139	0.9131	195	-0.2686	-0.8301	1.2451	-2.1631					
46	-0.21	-0.8008	1.3525	-1.5527	96	-0.2881	0.5078	1.0449	-0.2686	146	7.8516	0.2295	-7.8076	-1.9434	196	-0.2686	-0.7275	1.1182	-0.752					
47	-0.21	-0.8691	1.1035	-0.4785	97	-0.2637	0.6543	1.0596	0.1172	147	5.8301	0.0342	1.6455	-1.1377	197	-0.2881	-0.625	1.2451	-0.3369					
48	-0.2246	-0.9033	1.3086	-0.2051	98	-0.2734	0.7764	-7.8467	-2.4707	148	3.6133	-0.127	1.6211	-0.0049	198	-0.2832	-0.4883	1.2695	0.0439					
49	-0.2295	-0.9082	1.3086	0.166	99	-0.2686	0.8691	1.0986	-1.5527	149	1.709	-0.293	1.5625	0.2441	199	-0.2783	-0.3418	-5.0244	-1.7773					
50	-0.2588	-0.8838	-10	-4.0967	100	-0.2734	0.9424	1.123	-0.3564	150	0.6592	-0.4297	1.5576	0.5078	200	-0.2832	-0.1709	1.2549	-0.9912					



Tinggi Gel 4 cm  
 Periode 1.9 dt

No	Load cell (Volt)	Seasim (Volt)	Trimmetter 1 (Volt)	Trimmetter 2 (Volt)	No	Load cell (Volt)	Seasim (Volt)	Trimmetter 1 (Volt)	Trimmetter 2 (Volt)	No	Load cell (Volt)	Seasim (Volt)	Trimmetter 1 (Volt)	Trimmetter 2 (Volt)	No	Load cell (Volt)	Seasim (Volt)	Trimmetter 1 (Volt)	Trimmetter 2 (Volt)	No	Load cell (Volt)	Seasim (Volt)	Trimmetter 1 (Volt)	Trimmetter 2 (Volt)
1	-0.3613	-0.0732	1.0352	-0.0537	51	9.9951	1.1182	1.7334	1.0205	101	-0.2686	-0.6641	-10	-3.0957	151	-0.3564	-0.4248	-1.6699	-2.085					
2	-0.3711	0.1025	0.5713	0.4004	52	9.9951	1.04	-2.7051	-0.3369	102	-0.2979	-0.7715	1.4014	-2.0898	152	-0.3662	-0.2783	0.9424	-1.1768					
3	-0.3564	0.293	1.0498	0.4639	53	9.4482	0.9326	1.709	0.0098	103	-0.2979	-0.8887	1.0693	-0.6592	153	-0.3564	-0.1367	0.9766	-1.1963					
4	-0.3418	0.459	1.0742	0.4834	54	7.4512	0.791	1.6602	0.6299	104	-0.2832	-0.9521	1.3672	-0.2539	154	-0.376	0.0391	-1.7334	-0.9229					
5	-0.3467	0.6299	-5.1807	-1.4063	55	5.0732	0.6348	1.6602	0.8105	105	-0.2832	-0.9912	1.377	0.0977	155	-0.3418	0.2246	0.9521	-0.4053					
6	-0.3662	0.7666	1.1426	-0.7764	56	2.998	0.4541	1.6113	0.8252	106	-0.3027	-0.9912	-6.0352	-2.085	156	-0.3613	0.4053	0.9766	-0.7324					
7	-0.3613	0.9082	1.167	0.0146	57	1.3672	0.2588	-7.5928	-1.9385	107	-0.3174	-0.9717	1.4746	-1.2744	157	-0.3564	0.5762	-3.0127	-0.9814					
8	-0.3662	1.0059	1.1865	0.2441	58	0.0049	0.0488	1.5039	-1.2354	108	-0.3223	-0.9229	1.3281	-0.332	158	-0.3613	0.7422	1.0254	-0.4443					
9	-0.3857	1.1035	1.2598	0.4883	59	-0.3271	-0.1367	1.5234	-0.0684	109	-0.3271	-0.835	1.3379	0.0146	159	-0.3418	0.8887	1.0449	0.0439					
10	-0.3662	1.1523	-4.0381	-1.0938	60	-0.2051	-0.3027	1.4014	0.1172	110	-0.3223	-0.7324	1.3525	0.2002	160	-0.3613	1.0107	-9.209	-2.9346					
11	-0.3223	1.1768	1.333	-0.5469	61	-0.3027	-0.4541	1.4209	0.4053	111	-0.3271	-0.625	-7.0459	-2.2314	161	-0.3369	1.1133	1.1328	-1.792					
12	-0.2734	1.1572	1.3916	0.21	62	-0.3174	-0.5762	-10	-3.6426	112	-0.3271	-0.5225	1.3672	-1.3916	162	-0.3516	1.1816	0.9277	-0.5664					
13	-0.2051	1.123	1.4014	0.4883	63	-0.3125	-0.6689	1.2939	-2.4268	113	-0.332	-0.3955	1.3916	-0.3076	163	-0.3564	1.2158	1.1914	-0.1123					
14	-0.0781	1.0254	1.4258	0.6104	64	-0.332	-0.7813	-1.4014	-1.6113	114	-0.3369	-0.249	1.3818	0.0098	164	-0.3223	1.2109	1.2549	0.2686					
15	0.2197	0.9229	-5.4053	-1.3818	65	-0.3467	-0.8887	1.1963	-0.9131	115	-0.293	-0.1074	1.4355	0.3125	165	-0.3125	1.1719	-8.0566	-2.4365					
16	0.1953	0.7666	1.46	-0.7764	66	-0.3613	-0.957	1.1133	-0.3125	116	-0.1416	0.0684	-5.7715	-1.8018	166	-0.3076	1.0938	1.3184	-1.6064					
17	0.0146	0.6104	1.5088	0.166	67	-0.3662	-0.9766	-10	-4.3262	117	0.3223	0.2441	1.4893	-0.9619	167	-0.2783	0.9766	0.8301	-0.3906					
18	0.3027	0.4199	1.4795	0.3711	68	-0.3613	-0.9912	1.04	-2.9395	118	1.0254	0.4248	1.5234	-0.0342	168	-0.2295	0.835	1.377	0.0586					
19	0.5078	0.2344	1.5039	0.5811	69	-0.3662	-0.9619	-0.3174	-1.5576	119	2.2412	0.5908	1.5479	0.3613	169	-0.1025	0.6641	1.4697	0.3613					
20	0.1953	0.0293	-1.0693	-0.2002	70	-0.3516	-0.9277	0.9814	-0.9424	120	4.1309	0.752	1.5967	0.6006	170	-0.0244	0.4834	-8.1836	-2.4561					
21	0.0049	-0.1416	1.5039	0.1514	71	-0.3613	-0.8398	1.0059	-1.04	121	5.9473	0.8887	-5.3662	-1.3379	171	-0.0879	0.2783	1.4307	-1.665					
22	-0.0537	-0.3076	1.4844	0.4102	72	-0.3613	-0.7471	-2.6416	-1.1816	122	7.6074	1.0156	1.6504	-0.5957	172	-0.2441	0.0879	-0.0488	-0.7178					
23	-0.3027	-0.4443	1.46	0.542	73	-0.3564	-0.6396	0.9814	-0.5615	123	9.6582	1.1035	1.6943	0.3564	173	-0.2881	-0.1123	1.4258	-0.3223					
24	-0.2441	-0.5713	1.4404	0.5371	74	-0.3613	-0.542	0.9424	-0.9082	124	9.9951	1.167	1.6846	0.6396	174	-0.2783	-0.2539	1.4502	0.1758					
25	-0.2783	-0.6592	-3.584	-0.957	75	-0.3564	-0.4199	-0.7666	-0.4004	125	9.9951	1.1914	1.7334	0.918	175	-0.2783	-0.4248	1.4111	0.3125					
26	-0.2588	-0.7666	1.5234	-0.5811	76	-0.3711	-0.2734	-10	-4.3994	126	9.9951	1.1816	1.709	0.9814	176	-0.2832	-0.5469	1.4307	0.4443					
27	-0.2734	-0.8789	1.4111	0.1318	77	-0.3662	-0.127	0.9863	-2.8271	127	9.9951	1.1377	1.7285	1.0742	177	-0.2881	-0.6592	-5.0146	-1.5186					
28	-0.2783	-0.9473	1.3623	0.2295	78	-0.3516	0.0488	0.2539	-1.3574	128	9.9951	1.0596	-1.5527	0.0732	178	-0.2881	-0.7715	1.3965	-0.8691					
29	-0.293	-0.9668	1.377	0.3955	79	-0.3369	0.2393	-0.625	-1.2793	129	9.6484	0.9473	1.6992	0.2588	179	-0.2832	-0.9033	1.2354	-0.1807					
30	-0.3027	-0.9717	-2.5391	-0.8301	80	-0.3418	0.4199	0.9863	-1.2695	130	7.4463	0.8057	1.6846	0.7764	180	-0.2881	-0.9814	1.3672	0.0928					
31	-0.3125	-0.9424	1.3477	-0.4541	81	-0.3613	0.5908	-2.4268	-1.0889	131	4.7803	0.6396	1.6406	0.8691	181	-0.3027	-1.0156	1.3574	0.2246					
32	-0.3174	-0.8984	1.3135	0.0635	82	-0.3711	0.7471	1.04	-0.5762	132	2.6318	0.4639	1.6455	0.8936	182	-0.3174	-1.0205	-2.3438	-0.8203					
33	-0.3223	-0.8008	1.3379	0.2783	83	-0.3906	0.8887	1.1279	0.0488	133	0.918	0.2637	-7.4854	-1.8896	183	-0.3174	-1.0059	1.333	-0.5029					
34	-0.3369	-0.7178	1.3623	0.3662	84	-0.3809	1.0059	-10	-3.2568	134	-0.1123	0.0684	1.5186	-1.1572	184	-0.3271	-0.9521	1.3379	0.0781					
35	-0.332	-0.6055	-9.5557	-2.876	85	-0.3711	1.0986	1.1621	-2.0557	135	-0.3271	-0.1318	1.4502	-0.0879	185	-0.3223	-0.874	1.3232	0.21					
36	-0.3271	-0.5127	1.3281	-1.9727	86	-0.3613	1.1523	-0.4834	-1.0938	136	-0.2246	-0.2783	1.416	0.1465	186	-0.3369	-0.7568	1.3477	0.3662					
37	-0.3271	-0.3809	0.7813	-0.6348	87	-0.3369	1.1816	1.25	-0.3711	137	-0.3027	-0.4395	1.3721	0.3711	187	-0.3271	-0.6543	-5.0537	-1.5771					
38	-0.3271	-0.2441	1.3574	-0.1953	88	-0.3516	1.1719	1.2842	0.0928	138	-0.3418	-0.5615	-10	-3.7549	188	-0.3271	-0.5371	1.3672	-0.8789					
39	-0.2979	-0.0879	1.4258	0.2148	89	-0.3271	1.1279	-10	-3.8525	139	-0.3369	-0.6641	1.2598	-2.5439	189	-0.3223	-0.4297	1.3818	-0.1172					
40	-0.2637	0.0879	-7.6025	-2.4219	90	-0.293	1.0498	1.3477	-2.4854	140	-0.3223	-0.7715	-1.8701	-1.792	190	-0.3223	-0.2734	1.3916	0.1904					
41	-0.1318	0.2734	1.46	-1.5137	91	-0.2295	0.9375	0.7617	-0.8496	141	-0.3516	-0.8936	1.1523	-1.0449	191	-0.2783	-0.1465	1.4209	0.3516					
42	0.2881	0.4443	1.4209	-0.2393	92	-0.1123	0.8008	1.3965	-0.2979	142	-0.3662	-0.9668	1.1133	-0.376	192	-0.1221	0.0244	-3.8574	-1.1377					
43	1.0693	0.6152	1.5332	0.2393	93	0.0635	0.6445	1.4502	0.2246	143	-0.3564	-1.001	-10	-4.4141	193	0.2979	0.1953	1.4795	-0.5518					
44	2.3535	0.7617	1.5527	-0.498	94	-0.0537	0.459	1.416	0.3613	144	-0.3564	-1.0059	1.04	-2.9248	194	1.0889	0.3809	1.5381	0.2002					
45	4.126	0.8984	-9.3408	-2.6025	95	-0.2197	0.2588	1.46	0.5469	145	-0.3564	-0.9912	-0.3809	-1.6553	195	2.4316	0.5469	1.5381	0.4492					
46	5.9326	1.0059	1.6016	-1.5381	96	-0.2783	0.0586	-2.5439	-0.6836	146	-0.3613	-0.9473	-2.6807	-2.1973	196	4.1895	0.7178	1.6016	0.7031					
47	7.5146	1.0938	1.6895	-0.0488	97	-0.2197	-0.1318	1.4648	-0.3125	147	-0.3467	-0.8643	0.9717	-1.8213	197	5.9424	0.8594	-2.8662	-0.5713					
48	9.2334	1.1475	1.6455	0.3613	98	-0.2441	-0.2881	1.4453	0.2197	148	-0.3564	-0.7568	-0.5176	-0.9619	198	8.0566	1.001	1.665	-0.0098					
49	9.9951	1.1719	1.7285	0.7617	99	-0.2686	-0.4443	1.4453	0.4102	149	-0.3613	-0.6543	-10	-4.6826	199	9.9951	1.0986	1.6943	0.5762					
50	9.9951	1.1621	1.665	0.8496	100	-0.2734	-0.5615	1.4307	0.4736	150	-0.3613	-0.542	0.9424	-3.1885	200	9.9951	1.1768	1.7041	0.835					



Tinggi Gel 4 cm  
Periode 2.0 dt

No	Load cell (Volt)	Seasim (Volt)	Trimmetter 1 (Volt)	Trimmetter 2 (Volt)	No	Load cell (Volt)	Seasim (Volt)	Trimmetter 1 (Volt)	Trimmetter 2 (Volt)	No	Load cell (Volt)	Seasim (Volt)	Trimmetter 1 (Volt)	Trimmetter 2 (Volt)	No	Load cell (Volt)	Seasim (Volt)	Trimmetter 1 (Volt)	Trimmetter 2 (Volt)	No	Load cell (Volt)	Seasim (Volt)	Trimmetter 1 (Volt)	Trimmetter 2 (Volt)
1	-0.2686	0.9082	1.0791	0.3271	51	2.9541	0.7031	-1.2793	0.1074	101	-0.1465	-0.6889	1.4209	0.4346	151	-0.249	-0.6104	-10	-4.2676					
2	-0.2441	1.0303	1.1426	0.6738	52	1.2549	0.5664	1.5723	0.1953	102	-0.166	-0.7617	1.4209	0.498	152	-0.2441	-0.5127	0.9326	-2.6025					
3	-0.2344	1.1035	-10	-3.6572	53	0.0684	0.4053	1.5479	0.6543	103	-0.166	-0.8643	-6.6064	-1.958	153	-0.2344	-0.3857	0.9619	-1.1133					
4	-0.2393	1.1719	1.2256	-1.7578	54	-0.2051	0.249	1.4697	0.708	104	-0.1758	-0.9326	1.4063	-1.2646	154	-0.2393	-0.2344	-4.6777	-2.3584					
5	-0.2148	1.1865	-2.6318	-1.9092	55	-0.1025	0.0732	1.4404	0.7129	105	-0.1709	-0.9717	1.3867	-0.2539	155	-0.2441	-0.0879	0.9521	-1.2354					
6	-0.21	1.1865	1.3086	-1.0449	56	-0.2148	-0.0928	-8.7598	-2.4268	106	-0.1855	-0.9814	1.3721	0.0293	156	-0.249	0.1025	0.918	-1.2695					
7	-0.1953	1.1377	1.3428	-0.1367	57	-0.2246	-0.2246	1.3184	-1.792	107	-0.1709	-0.9668	1.3916	0.2393	157	-0.2246	0.2979	-1.8799	-0.9424					
8	-0.1514	1.0791	1.3867	0.2588	58	-0.2393	-0.3711	-1.0107	-1.0059	108	-0.1904	-0.9131	-4.248	-1.4111	158	-0.2295	0.4883	0.9326	-0.4688					
9	0.0146	0.9717	1.416	0.4639	59	-0.2295	-0.4883	1.2061	-0.6445	109	-0.2002	-0.835	1.3916	-0.8057	159	-0.2295	0.6689	0.9717	-0.6787					
10	0.2197	0.8594	-7.3584	-2.085	60	-0.2295	-0.5859	1.1426	0.0049	110	-0.1904	-0.7324	1.3916	-0.0928	160	-0.2637	0.835	-3.8867	-1.2402					
11	0.1074	0.7129	1.46	-1.3721	61	-0.2344	-0.6738	0.6299	-0.1855	111	-0.1904	-0.6348	1.4014	0.1709	161	-0.2441	0.9766	1.0205	-0.6152					
12	0.0342	0.5713	1.3184	-0.1123	62	-0.2539	-0.7666	1.0596	-0.6104	112	-0.1709	-0.5371	1.4209	0.3467	162	-0.2441	1.084	1.0547	0.0049					
13	0.2881	0.3955	1.4844	0.2051	63	-0.2295	-0.8691	-3.6035	-1.1768	113	-0.0732	-0.415	-7.4658	-2.2754	163	-0.2393	1.1475	-10	-4.0234					
14	0.5127	0.2393	1.5283	0.498	64	-0.2637	-0.9277	1.001	-0.708	114	0.1367	-0.2588	1.4648	-1.5137	164	-0.2246	1.1914	1.1182	-2.6709					
15	0.3906	0.0635	-7.0752	-2.0654	65	-0.2539	-0.9619	0.9619	-0.1953	115	0.5371	-0.1123	1.4502	-0.21	165	-0.2441	1.1865	-1.6162	-1.626					
16	0.3125	-0.0977	1.5186	-1.1914	66	-0.2441	-0.9668	-7.3828	-2.6074	116	1.1621	0.0781	1.5137	0.166	166	-0.21	1.1523	1.2012	-0.9131					
17	0.1172	-0.2246	1.5039	-0.1709	67	-0.2393	-0.9521	0.9424	-1.6357	117	2.4854	0.2734	1.5625	0.498	167	-0.2197	1.0986	1.2939	-0.0244					
18	-0.0977	-0.3564	1.4941	0.1855	68	-0.2393	-0.9082	0.9375	-0.6494	118	4.3115	0.4688	1.5723	0.6494	168	-0.2148	1.0059	1.2695	0.2051					
19	-0.1221	-0.4736	1.4795	0.3613	69	-0.2441	-0.835	-4.0625	-1.8945	119	5.9668	0.6445	1.6309	0.8105	169	-0.1904	0.9033	1.3379	0.459					
20	-0.0684	-0.5713	-9.6191	-2.9199	70	-0.249	-0.7373	0.9326	-1.0059	120	7.9346	0.8105	0.3125	0.4785	170	-0.1563	0.7861	-4.873	-1.416					
21	-0.1904	-0.6641	1.4355	-1.416	71	-0.2393	-0.6396	0.9424	-1.0693	121	9.834	0.9424	1.6895	0.6104	171	-0.1074	0.6592	1.3965	-0.7129					
22	-0.1416	-0.7471	-2.0215	-1.665	72	-0.249	-0.542	0.8887	-0.0439	122	9.9951	1.0498	1.7236	0.9473	172	-0.0244	0.5225	1.416	0.0195					
23	-0.21	-0.8643	1.4063	-1.0156	73	-0.2441	-0.4199	-9.5215	-3.1836	123	9.9951	1.1182	1.7188	1.0547	173	0.0537	0.3711	1.416	0.3271					
24	-0.2148	-0.9229	1.4063	-0.21	74	-0.2637	-0.2588	0.9375	-1.8262	124	9.9951	1.1621	1.7529	1.1328	174	-0.0146	0.2148	1.4355	0.4492					
25	-0.2002	-0.9717	1.3721	0.0293	75	-0.2441	-0.1074	0.9229	-0.8154	125	9.9951	1.167	-7.2461	-1.5576	175	-0.127	0.0488	-9.1846	-2.6953					
26	-0.1807	-0.9717	1.3965	0.2539	76	-0.2539	0.0977	-5.3906	-2.3242	126	9.9951	1.1426	1.7529	-0.6592	176	-0.1611	-0.1123	1.4111	-1.958					
27	-0.2002	-0.9619	-2.2217	-0.8008	77	-0.2637	0.293	0.9375	-1.3672	127	9.9951	1.084	1.1963	0.1563	177	-0.1611	-0.2393	-1.3281	-1.1816					
28	-0.1953	-0.9131	1.3818	-0.3662	78	-0.2539	0.4883	0.9424	-0.4883	128	9.7412	1.0156	1.6992	0.3516	178	-0.1709	-0.3857	1.4063	-0.7178					
29	-0.2051	-0.8398	1.377	0.0781	79	-0.2197	0.6592	-6.9385	-2.5879	129	7.0703	0.918	1.7041	0.7764	179	-0.1611	-0.498	1.416	-0.0098					
30	-0.2197	-0.7324	-10	-4.0332	80	-0.2344	0.8105	0.9863	-1.5918	130	4.5898	0.8057	1.6455	0.835	180	-0.1758	-0.6104	1.3818	0.1514					
31	-0.1953	-0.6396	1.416	-2.71	81	-0.2295	0.9473	1.0205	-0.4395	131	2.373	0.6787	1.6943	0.9326	181	-0.1709	-0.6885	1.416	0.3662					
32	-0.2051	-0.5371	-0.708	-1.4697	82	-0.2637	1.0498	-10	-4.2773	132	0.4248	0.5469	-7.7441	-1.9775	182	-0.1709	-0.7959	-4.502	-1.4502					
33	-0.1953	-0.4199	1.4111	-0.8398	83	-0.2393	1.1182	1.1133	-2.6465	133	-0.127	0.3906	1.5186	-1.2109	183	-0.1758	-0.8838	1.3916	-0.8105					
34	-0.0684	-0.2637	1.4502	-0.1025	84	-0.2344	1.1621	-3.7305	-2.4268	134	-0.2197	0.2295	0.6396	-0.3369	184	-0.1758	-0.9473	1.3525	-0.1465					
35	0.2197	-0.1172	1.46	0.1758	85	-0.2246	1.1768	1.2549	-1.4648	135	-0.1807	0.0586	1.4111	0.0098	185	-0.1709	-0.9717	1.3721	0.1416					
36	0.7373	0.0781	1.5186	0.4492	86	-0.2246	1.167	1.2305	-0.3613	136	-0.2002	-0.1123	1.3574	0.3174	186	-0.1807	-0.9814	1.3477	0.2393					
37	1.6748	0.2637	-3.9648	-1.1182	87	-0.2148	1.123	1.2793	0.0391	137	-0.2148	-0.2393	1.2988	0.4199	187	-0.1953	-0.957	-4.707	-1.5039					
38	3.2861	0.459	1.5723	-0.6152	88	-0.21	1.0547	1.4063	0.3662	138	-0.2148	-0.3955	1.2402	0.4199	188	-0.2002	-0.9131	1.3281	-1.001					
39	5.1855	0.625	1.6064	0.3174	89	-0.1758	0.9521	-8.2617	-2.4561	139	-0.2197	-0.5029	-5.9033	-1.748	189	-0.2051	-0.8252	1.377	-0.1123					
40	6.8457	0.791	1.6553	0.6299	90	-0.1123	0.8398	1.4551	-1.4697	140	-0.2344	-0.6006	1.1377	-1.2256	190	-0.21	-0.7324	1.3477	0.083					
41	9.0723	0.918	1.6797	0.8301	91	0.0439	0.7031	1.3184	-0.2783	141	-0.2246	-0.6885	0.7129	-0.3955	191	-0.2148	-0.6299	1.4111	0.332					
42	9.9951	1.0352	1.6699	0.9717	92	0.0732	0.5566	1.4209	0.0488	142	-0.2539	-0.7861	1.04	-0.1709	192	-0.1953	-0.542	-3.5742	-1.167					
43	9.9951	1.1084	1.7285	1.0352	93	0.0293	0.3906	1.4502	0.3711	143	-0.2441	-0.8789	1.0156	-0.6006	193	-0.1709	-0.4102	1.4307	-0.6641					
44	9.9951	1.1621	-1.748	-0.0586	94	-0.0635	0.2197	1.4453	0.4932	144	-0.2344	-0.9375	-3.6377	-1.2158	194	-0.1074	-0.2637	1.4111	0.0439					
45	9.9951	1.1719	1.7383	0.2881	95	-0.1123	0.0439	1.4648	0.5859	145	-0.2441	-0.9717	0.9668	-0.6934	195	0.166	-0.1025	1.4893	0.3516					
46	9.9951	1.167	1.748	0.874	96	-0.0879	-0.1172	-5.4053	-1.499	146	-0.2441	-0.9766	0.9326	-0.2441	196	0.6738	0.0879	1.499	0.5029					
47	9.9951	1.1133	1.7188	0.9619	97	-0.0488	-0.2393	1.4648	-1.0107	147	-0.2344	-0.9521	-4.1992	-1.6357	197	1.543	0.2881	-7.71	-2.1533					
48	9.9951	1.0498	1.7188	1.084	98	-0.1416	-0.376	1.0791	-0.1123	148	-0.2393	-0.8984	0.918	-0.9131	198	3.0859	0.4736	1.5479	-1.3818					
49	8.0273	0.9521	1.6699	1.0547	99	-0.1123	-0.4883	1.4453	0.0732	149	-0.2588	-0.8105	0.9521	-1.0107	199	4.9902	0.6494	0.6348	-0.2686					
50	5.459	0.8447	1.665	1.0693	100	-0.1465	-0.5859	1.4404	0.3516	150	-0.249	-0.7129	0.4004	-0.2197	200	6.8945	0.7959	1.6162	0.1807					



Tinggi Gel 2 cm  
Periode 1.2 dt

No	Load cell (Volt)	Seasim (Volt)	Trimmetr 1 (Volt)	Trimmetr 2 (Volt)	No	Load cell (Volt)	Seasim (Volt)	Trimmetr 1 (Volt)	Trimmetr 2 (Volt)	No	Load cell (Volt)	Seasim (Volt)	Trimmetr 1 (Volt)	Trimmetr 2 (Volt)	No	Load cell (Volt)	Seasim (Volt)	Trimmetr 1 (Volt)	Trimmetr 2 (Volt)	No	Load cell (Volt)	Seasim (Volt)	Trimmetr 1 (Volt)	Trimmetr 2 (Volt)
1	-0.1318	0.249	1.46	0.6152	51	-0.1758	0.2588	1.4307	-1.3281	101	-0.2148	0.2441	1.4063	-0.4639	151	-0.3027	0.1465	1.3965	0.2588					
2	-0.2002	0.2783	-3.7646	-0.9424	52	-0.2197	0.2539	-1.25	-0.7764	102	-0.2344	0.1953	1.416	0.2197	152	-0.2979	0.0684	1.4014	0.4199					
3	-0.1758	0.2832	1.4355	-0.6787	53	-0.21	0.2197	1.3965	-0.4736	103	-0.3027	0.1318	1.3916	0.3516	153	-0.3125	-0.0098	-10	-3.1055					
4	-0.2148	0.2734	0.3076	-0.083	54	-0.2441	0.1758	1.4258	0.2246	104	-0.293	0.0635	1.4209	0.5371	154	-0.3174	-0.0977	1.3965	-2.1143					
5	-0.1953	0.2344	1.4209	0.0732	55	-0.2881	0.1123	1.3867	0.3418	105	-0.3125	-0.0195	-9.4482	-2.7979	155	-0.3174	-0.1465	-0.1611	-0.9766					
6	-0.2393	0.1855	1.416	0.459	56	-0.293	0.0488	1.4404	0.5469	106	-0.3027	-0.0977	1.4111	-1.8408	156	-0.3076	-0.21	1.3965	-0.4883					
7	-0.2588	0.1172	1.4014	0.5371	57	-0.3125	-0.0439	-8.9502	-2.6465	107	-0.3076	-0.1514	0.1953	-0.791	157	-0.2783	-0.2441	1.4063	0.0586					
8	-0.2979	0.0391	1.4307	0.6299	58	-0.3076	-0.1074	1.4111	-1.709	108	-0.3027	-0.2051	1.4014	-0.3027	158	-0.2051	-0.2832	1.3965	0.2295					
9	-0.2881	-0.0488	-8.2373	-2.334	59	-0.3125	-0.1709	0.4785	-0.6641	109	-0.2783	-0.2393	1.416	0.1074	159	-0.1416	-0.2881	1.4209	0.4297					
10	-0.2979	-0.127	1.4014	-1.5527	60	-0.2979	-0.2148	1.416	-0.1855	110	-0.21	-0.2734	1.4014	0.3223	160	-0.0146	-0.2979	-9.5264	-2.9053					
11	-0.2979	-0.1855	0.4297	-0.5518	61	-0.2783	-0.2637	1.3965	0.1953	111	-0.127	-0.2783	1.416	0.4346	161	0.1514	-0.2637	1.4453	-1.3232					
12	-0.3027	-0.2246	1.4063	-0.1611	62	-0.2246	-0.2832	1.4111	0.4004	112	0.0195	-0.2783	-9.6094	-2.8662	162	0.293	-0.2393	-3.2666	-2.0313					
13	-0.2734	-0.2734	1.416	0.2051	63	-0.1563	-0.2979	1.4014	0.4541	113	0.2197	-0.2539	1.4404	-1.3525	163	0.1855	-0.1807	1.46	-1.2793					
14	-0.2148	-0.2979	1.4014	0.376	64	-0.0195	-0.2881	-8.1006	-2.3633	114	0.3125	-0.2197	-3.1348	-1.9434	164	-0.0244	-0.1318	1.1621	-0.332					
15	-0.1123	-0.3076	1.416	0.4834	65	0.1709	-0.2686	1.5332	-1.5039	115	0.1367	-0.166	1.4502	-1.2646	165	-0.166	-0.0439	1.46	0					
16	0.0244	-0.2979	-9.5557	-2.8174	66	0.2979	-0.2197	-2.0996	-1.3281	116	-0.0879	-0.1123	1.3672	-0.21	166	-0.0439	0.0293	1.4551	0.3027					
17	0.2051	-0.2783	1.4355	-1.3135	67	0.1953	-0.1709	1.4307	-0.8789	117	-0.1709	-0.0293	1.46	0.0439	167	-0.1758	0.1172	1.46	0.4932					
18	0.2979	-0.2393	-3.1152	-1.9141	68	-0.0635	-0.1025	1.4648	0.0391	118	0.0098	0.0537	1.4697	0.3711	168	-0.1416	0.1709	1.4648	0.5664					
19	0.1416	-0.1904	1.4502	-1.2402	69	-0.1855	-0.0244	1.4307	0.1807	119	-0.1416	0.127	1.4502	0.4785	169	-0.1514	0.2295	-10	-3.1934					
20	-0.1074	-0.127	1.3672	-0.1904	70	-0.0488	0.0635	1.4893	0.4883	120	-0.1318	0.1904	1.4746	0.6055	170	-0.166	0.2539	1.4355	-1.5137					
21	-0.1855	-0.0488	1.4502	0.0537	71	-0.1367	0.1367	1.4258	0.5176	121	-0.1172	0.2393	-8.6816	-2.4756	171	-0.2002	0.2686	-4.4873	-2.4072					
22	-0.0488	0.0488	1.4795	0.3906	72	-0.1514	0.21	1.4844	0.6738	122	-0.21	0.2637	1.4502	-1.0693	172	-0.1953	0.249	1.416	-1.8553					
23	-0.1709	0.1221	1.4502	0.4834	73	-0.1514	0.2539	-8.6914	-2.4707	123	-0.166	0.2734	-2.7637	-1.665	173	-0.2148	0.2295	0.21	-0.6641					
24	-0.127	0.2002	1.4648	0.625	74	-0.1953	0.2881	1.4648	-1.0205	124	-0.2148	0.2637	1.4355	-1.0693	174	-0.249	0.1709	1.3965	-0.3271					
25	-0.1465	0.2539	-9.2578	-2.6514	75	-0.1807	0.293	-2.7881	-1.6748	125	-0.2051	0.2295	1.1035	-0.1758	175	-0.2832	0.1123	1.4209	0.21					
26	-0.1953	0.2979	1.4453	-1.1377	76	-0.2051	0.2881	1.4502	-1.0156	126	-0.2246	0.1758	1.416	0.0635	176	-0.3174	0.0391	1.377	0.3174					
27	-0.2002	0.3076	-3.1201	-1.8262	77	-0.2246	0.2539	1.1963	-0.1563	127	-0.2734	0.1123	1.4111	0.3711	177	-0.3027	-0.0342	1.416	0.498					
28	-0.2295	0.3027	1.4355	-1.1475	78	-0.2539	0.21	1.416	0.1416	128	-0.2783	0.0293	1.3916	0.4736	178	-0.3174	-0.1123	-4.3506	-1.2793					
29	-0.21	0.2637	1.0352	-0.249	79	-0.2783	0.1367	1.3916	0.4102	129	-0.3174	-0.0488	1.4014	0.542	179	-0.3027	-0.166	1.4111	-0.7324					
30	-0.2393	0.2197	1.4063	0.0537	80	-0.3125	0.0586	1.3965	0.542	130	-0.3076	-0.1221	-3.5352	-0.9619	180	-0.3076	-0.2197	1.377	0					
31	-0.2832	0.1416	1.4014	0.3613	81	-0.2979	-0.0342	1.3867	0.5371	131	-0.3174	-0.1758	1.3916	-0.5566	181	-0.2881	-0.2539	1.416	0.2783					
32	-0.3027	0.0732	1.3916	0.498	82	-0.2979	-0.1074	-2.8369	-0.7031	132	-0.293	-0.2295	1.3965	0.127	182	-0.2441	-0.2881	1.4014	0.4004					
33	-0.3125	-0.0195	1.4014	0.5371	83	-0.3076	-0.1709	1.3916	-0.415	133	-0.293	-0.2686	1.3965	0.3174	183	-0.1563	-0.2979	-10	-3.7939					
34	-0.3223	-0.0928	-3.3008	-0.8594	84	-0.3027	-0.2148	1.4111	0.2393	134	-0.2393	-0.2979	1.416	0.4639	184	-0.0391	-0.2832	1.4111	-1.8994					
35	-0.3027	-0.1611	1.3916	-0.5176	85	-0.2979	-0.2686	1.3818	0.3369	135	-0.1758	-0.3076	-10	-3.7451	185	0.127	-0.2588	-5.6934	-3.0322					
36	-0.3027	-0.1953	1.4063	0.1855	86	-0.2246	-0.293	1.4404	0.5273	136	-0.0635	-0.2979	1.4258	-1.8311	186	0.249	-0.2197	1.416	-2.1143					
37	-0.2783	-0.2539	1.3916	0.3174	87	-0.1611	-0.3076	-10	-3.3301	137	0.1074	-0.2734	-4.8389	-2.7637	187	0.2051	-0.166	-0.6689	-1.167					
38	-0.2441	-0.2734	1.4209	0.5127	88	-0.0488	-0.3027	1.4307	-1.543	138	0.2832	-0.2393	1.4404	-1.8604	188	-0.0342	-0.1025	1.4258	-0.7275					
39	-0.1611	-0.2979	-10	-3.8135	89	0.1074	-0.2832	-4.1113	-2.417	139	0.2197	-0.1807	-0.1416	-0.9277	189	-0.1855	-0.0146	1.4746	0.0488					
40	-0.0342	-0.2783	1.4404	-1.8115	90	0.2686	-0.249	1.4453	-1.5723	140	0.0098	-0.1221	1.4404	-0.5176	190	-0.1221	0.0684	1.4258	0.21					
41	0.1563	-0.2734	-4.9707	-2.832	91	0.21	-0.1953	0.3711	-0.6836	141	-0.1855	-0.0342	1.46	0.1172	191	-0.166	0.1465	1.4844	0.5176					
42	0.2588	-0.2246	1.4502	-1.8506	92	-0.0293	-0.1416	1.4648	-0.2783	142	-0.1318	0.0488	1.4404	0.3027	192	-0.1758	0.21	1.4209	0.5273					
43	0.1807	-0.1904	-0.0684	-0.9521	93	-0.2002	-0.0635	1.4551	0.1758	143	-0.1465	0.1318	1.4648	0.5225	193	-0.1563	0.2637	1.499	0.6836					
44	-0.0635	-0.1221	1.46	-0.4541	94	-0.1172	0.0244	1.46	0.4053	144	-0.1904	0.1953	1.4307	0.5664	194	-0.1855	0.2881	-9.0869	-2.5928					
45	-0.1904	-0.0537	1.4453	0.083	95	-0.1514	0.1074	1.4551	0.5176	145	-0.1758	0.2539	1.4551	0.6592	195	-0.1807	0.3027	1.4551	-1.0986					
46	-0.0879	0.0439	1.46	0.3564	96	-0.1807	0.1709	1.4404	0.625	146	-0.1953	0.2783	-8.2324	-2.3145	196	-0.2246	0.2832	-2.9834	-1.792					
47	-0.1563	0.1074	1.4893	0.4932	97	-0.1563	0.2246	1.4453	0.6348	147	-0.2002	0.2979	1.4355	-1.3281	197	-0.2295	0.2539	1.4404	-1.0547					
48	-0.166	0.1807	1.4453	0.6152	98	-0.1758	0.2637	-6.4355	-1.7236	148	-0.21	0.2881	-2.3633	-1.4063	198	-0.2393	0.2002	1.3818	-0.1611					
49	-0.1709	0.2246	1.4404	0.625	99	-0.1904	0.2734	1.4258	-1.3232	149	-0.2197	0.2637	1.4209	-0.8252	199	-0.2832	0.1367	1.4111	0.1758					
50	-0.1758	0.2588	-6.4014	-1.7139	100	-0.2197	0.2686	-1.2549	-0.7861	150	-0.2441	0.2051	1.4014	-0.0244	200	-0.2881	0.0586	1.3965	0.3662					



Tinggi Gel 2 cm  
Periode 1.3 dt

No	Load cell (Volt)	Seasim (Volt)	Trimmeter 1 (Volt)	Trimmeter 2 (Volt)	No	Load cell (Volt)	Seasim (Volt)	Trimmeter 1 (Volt)	Trimmeter 2 (Volt)	No	Load cell (Volt)	Seasim (Volt)	Trimmeter 1 (Volt)	Trimmeter 2 (Volt)	No	Load cell (Volt)	Seasim (Volt)	Trimmeter 1 (Volt)	Trimmeter 2 (Volt)
1	-0.2832	0.1172	1.3623	0.5127	51	-0.2881	0.2881	1.3918	0.3906	101	-0.2539	0.3516	-10	-3.0371	151	-0.1953	0.3076	1.4063	-2.1973
2	-0.2637	0.0391	1.418	0.7178	52	-0.2783	0.2246	-10	-3.6914	102	-0.2686	0.3223	1.3721	-2.1191	152	-0.2441	0.3271	-0.5273	-1.1572
3	-0.2686	-0.0537	1.3525	0.6348	53	-0.2783	0.1514	1.3867	-2.0654	103	-0.2783	0.2832	-1.0107	-1.1426	153	-0.2686	0.3223	1.3916	-0.5957
4	-0.2051	-0.1221	1.4307	0.7129	54	-0.2539	0.0635	-1.9678	-1.7871	104	-0.2832	0.2148	1.3672	-0.625	154	-0.2881	0.3076	1.3965	0.0342
5	-0.127	-0.1855	-6.3525	-1.7432	55	-0.249	-0.0293	1.3916	-1.0547	105	-0.2832	0.1416	1.4063	0.0586	155	-0.2783	0.2637	1.3721	0.2441
6	-0.0098	-0.2295	1.46	-1.3086	56	-0.1709	-0.1123	1.4014	-0.2051	106	-0.2588	0.0537	1.3721	0.2295	156	-0.2734	0.2051	1.3916	0.4443
7	0.1709	-0.2686	-2.3047	-1.1621	57	-0.1025	-0.1709	1.416	0.0635	107	-0.2393	-0.0391	1.416	0.459	157	-0.2783	0.127	-6.3281	-1.8848
8	0.3516	-0.293	1.46	-0.7715	58	0.0293	-0.2246	1.4355	0.3125	108	-0.1807	-0.1221	-9.2334	-2.7979	158	-0.2539	0.0537	1.4014	-1.2549
9	0.3418	-0.3125	0.5566	-0.1904	59	0.2148	-0.2588	1.4404	0.4443	109	-0.1074	-0.1758	1.4307	-1.2549	159	-0.2295	-0.0439	0.4834	-0.415
10	0.127	-0.3027	1.4746	0.0244	60	0.4248	-0.293	1.4502	0.542	110	0.0488	-0.2344	-3.7402	-2.1387	160	-0.1855	-0.1172	1.4111	-0.127
11	-0.0537	-0.2979	1.4551	0.3662	61	0.3174	-0.3027	1.4355	0.5908	111	0.2637	-0.2734	1.4453	-1.4551	161	-0.0977	-0.1807	1.4258	0.2588
12	-0.0146	-0.2686	1.4697	0.5322	62	0.1123	-0.3076	1.4648	0.6201	112	0.415	-0.2979	-0.5664	-0.874	162	0.0342	-0.2197	1.416	0.4102
13	0.083	-0.2295	1.4697	0.5859	63	-0.0635	-0.2979	-8.8506	-1.8994	113	0.3271	-0.3174	1.46	-0.4834	163	0.2393	-0.2637	1.4404	0.5322
14	-0.0684	-0.1709	1.4648	0.6738	64	0.0537	-0.2734	1.4697	-1.3965	114	0.0342	-0.3125	1.4453	0.1172	164	0.3662	-0.2881	1.4355	0.5908
15	-0.0537	-0.1074	1.4453	0.6543	65	0.0977	-0.2246	-0.7031	-0.7227	115	-0.0879	-0.3027	1.4697	0.3174	165	0.2344	-0.3076	1.4697	0.6201
16	-0.1025	-0.0195	-8.7061	-2.3975	66	-0.0537	-0.1758	1.4648	-0.4102	116	0.0879	-0.2686	1.4795	0.4688	166	0.0098	-0.2979	-10	-3.5156
17	-0.127	0.0732	1.4697	-1.0645	67	-0.0391	-0.1074	1.4648	0.2295	117	0.0781	-0.2295	1.4697	0.5762	167	-0.0732	-0.293	1.4697	-1.709
18	-0.1416	0.1611	-4.5557	-2.1631	68	-0.1221	-0.0244	1.4404	0.3076	118	-0.0732	-0.1709	1.4648	0.5957	168	0.0879	-0.249	-4.043	-2.417
19	-0.1514	0.2246	1.416	-1.5674	69	-0.1318	0.0732	1.4502	0.5322	119	0.0195	-0.1025	-9.8291	-2.8027	169	0.0488	-0.2148	1.4697	-1.6162
20	-0.166	0.2783	-0.8105	-0.8545	70	-0.1318	0.1465	1.4404	0.5762	120	-0.1465	-0.0195	1.4453	-1.2988	170	-0.0732	-0.1514	0.7324	-0.5469
21	-0.2051	0.3174	1.4014	-0.4883	71	-0.1563	0.2197	1.4355	0.6934	121	-0.1123	0.0684	-4.9756	-2.4414	171	0.0049	-0.0928	1.4551	-0.2881
22	-0.2393	0.332	1.4063	0.1855	72	-0.166	0.2686	1.3965	0.6592	122	-0.1465	0.1514	1.4307	-1.7871	172	-0.1416	0.0049	1.46	0.2539
23	-0.249	0.3271	1.3721	0.332	73	-0.2051	0.3076	1.4111	0.7275	123	-0.1611	0.2295	-1.6846	-1.2256	173	-0.1025	0.0879	1.4258	0.3223
24	-0.2783	0.3076	1.4697	0.5566	74	-0.2393	0.3174	-6.3135	-1.6895	124	-0.166	0.2832	1.4063	-0.8057	174	-0.1416	0.1758	1.4453	0.5371
25	-0.2881	0.2637	-8.7598	-2.5537	75	-0.2637	0.3174	1.3965	-1.0889	125	-0.1953	0.3223	1.3916	0.0586	175	-0.1807	0.2344	1.4111	0.542
26	-0.293	0.2051	1.3965	-1.6748	76	-0.2783	0.2979	0.8887	-0.1807	126	-0.2393	0.3418	1.3867	0.2197	176	-0.166	0.293	1.4355	0.6836
27	-0.2832	0.127	0.0342	-0.7178	77	-0.2979	0.2686	1.3867	0.1318	127	-0.2637	0.3467	1.4111	0.5127	177	-0.1904	0.3223	-10	-3.7012
28	-0.2832	0.0439	1.3916	-0.249	78	-0.293	0.1953	1.3916	0.4102	128	-0.2686	0.3271	-9.0137	-2.7686	178	-0.2441	0.3467	1.4111	-1.7139
29	-0.2686	-0.0488	1.3867	0.1563	79	-0.293	0.1367	0.542	0.1221	129	-0.2881	0.2881	1.3916	-1.2305	179	-0.2686	0.3418	-2.6953	-2.0654
30	-0.2148	-0.127	1.4063	0.3662	80	-0.2783	0.0439	1.3916	0.3174	130	-0.2881	0.2295	-2.8369	-1.8066	180	-0.2832	0.3223	1.3965	-1.1475
31	-0.1221	-0.1904	1.4258	0.4639	81	-0.249	-0.0293	-3.5303	-1.04	131	-0.2832	0.1563	1.3916	-1.0303	181	-0.293	0.2783	1.3818	-0.2881
32	-0.0146	-0.2441	-10	-3.3496	82	-0.2051	-0.1172	1.3965	-0.7324	132	-0.2783	0.0781	1.3867	-0.1953	182	-0.293	0.2197	1.3916	0.1172
33	0.1514	-0.2881	1.4258	-1.626	83	-0.1416	-0.1758	1.1328	0.0635	133	-0.249	-0.0195	1.3965	0.1367	183	-0.2734	0.1367	1.4258	0.3125
34	0.3516	-0.3076	-6.3623	-3.0859	84	-0.0293	-0.2344	1.4111	0.0928	134	-0.1709	-0.0977	1.4111	0.3467	184	-0.2734	0.0586	-9.0674	-2.7441
35	0.3564	-0.3174	1.4502	-2.2119	85	0.1807	-0.2637	1.4404	0.4639	135	-0.083	-0.1611	1.3916	0.459	185	-0.249	-0.0342	1.377	-1.958
36	0.1514	-0.3174	-1.8115	-1.5137	86	0.3711	-0.2979	1.4209	0.459	136	0.0049	-0.2148	1.4258	0.5225	186	-0.2002	-0.1172	-1.0107	-1.1133
37	-0.0439	-0.3027	1.4648	-0.9814	87	0.3271	-0.3027	1.4648	0.6543	137	0.1807	-0.2588	-8.8135	-2.5732	187	-0.1172	-0.1807	1.3916	-0.7227
38	-0.0391	-0.2783	1.4648	-0.0732	88	0.1221	-0.3076	1.4355	0.6055	138	0.3418	-0.2832	1.4404	-1.1768	188	-0.0146	-0.2246	1.4307	0.0488
39	0.0879	-0.2344	1.46	0.1074	89	-0.0586	-0.2881	1.4941	0.7129	139	0.2734	-0.2979	-4.0674	-2.1436	189	0.1563	-0.2734	1.4014	0.1123
40	-0.0684	-0.1807	1.4746	0.4053	90	-0.0342	-0.2637	-10	-3.2617	140	0.0391	-0.3027	1.4551	-1.4648	190	0.3516	-0.2979	1.4941	0.4492
41	-0.0537	-0.1172	1.4453	0.4883	91	0.0537	-0.21	1.4941	-1.4746	141	-0.083	-0.2881	0.2832	-0.5957	191	0.332	-0.3125	1.4258	0.459
42	-0.0781	-0.0293	1.4648	0.6152	92	-0.083	-0.1611	-4.2285	-2.4023	142	-0.0195	-0.2539	1.4551	-0.2881	192	0.1221	-0.3076	1.4844	0.625
43	-0.1416	0.0586	1.4209	0.625	93	-0.0537	-0.0879	1.4746	-1.5771	143	0.0391	-0.2148	1.4697	0.2197	193	-0.0781	-0.3027	1.4355	0.5762
44	-0.127	0.1416	1.4453	0.6836	94	-0.1123	-0.0049	-0.5469	-0.9277	144	-0.0537	-0.166	1.46	0.376	194	-0.083	-0.2686	1.4844	0.6836
45	-0.1465	0.2197	-9.8828	-2.7979	95	-0.127	0.0879	1.46	-0.5371	145	-0.0439	-0.1025	1.4697	0.5469	195	0.0342	-0.2246	-8.6865	-2.4854
46	-0.1611	0.2783	1.4258	-1.25	96	-0.1514	0.166	1.3232	0.1025	146	-0.1416	-0.0146	1.4355	0.5908	196	-0.1123	-0.1709	1.4746	-1.0596
47	-0.1855	0.3174	-3.3984	-1.9629	97	-0.1758	0.2393	1.4355	0.2344	147	-0.1172	0.0684	1.4746	0.6592	197	-0.0684	-0.1123	-3.2227	-1.8506
48	-0.2393	0.3418	1.4063	-1.1914	98	-0.1709	0.293	1.3916	0.4688	148	-0.1709	0.1465	-10	-3.6621	198	-0.1025	-0.0195	1.46	-1.2354
49	-0.249	0.3418	1.377	-0.1904	99	-0.21	0.332	1.4209	0.6006	149	-0.166	0.2148	1.4258	-1.7432	199	-0.1318	0.0684	-0.3467	-0.6787
50	-0.2783	0.3271	1.4063	0.1367	100	-0.2441	0.3467	1.3965	0.625	150	-0.1611	0.2734	-6.792	-3.2764	200	-0.1514	0.1465	1.4404	-0.376



Tinggi Gel 2 cm  
Periode 1.4 dt

No	Load cell (Volt)	Seasim (Volt)	Trimmer 1 (Volt)	Trimmer 2 (Volt)	No	Load cell (Volt)	Seasim (Volt)	Trimmer 1 (Volt)	Trimmer 2 (Volt)	No	Load cell (Volt)	Seasim (Volt)	Trimmer 1 (Volt)	Trimmer 2 (Volt)	No	Load cell (Volt)	Seasim (Volt)	Trimmer 1 (Volt)	Trimmer 2 (Volt)
1	0.3418	-0.2588	1.4453	0.625	51	-0.4248	0.166	0.4053	-0.3076	101	-0.4395	0.3418	1.3574	0.0293	151	-0.3174	-0.0684	1.4209	0.6445
2	0.1709	-0.2979	1.4893	0.6689	52	-0.4004	0.0781	1.3818	-0.1074	102	-0.4443	0.3662	1.3574	0.293	152	-0.3564	0.0244	1.4014	0.6787
3	-0.083	-0.3125	-10	-3.3838	53	-0.3076	-0.0195	1.4209	0.3516	103	-0.4492	0.3613	1.3672	0.459	153	-0.3613	0.1025	1.3916	0.6592
4	-0.1758	-0.3223	1.4746	-1.6016	54	-0.1758	-0.1025	1.3965	0.3955	104	-0.4541	0.3467	-10	-3.2666	154	-0.4053	0.1758	-6.0547	-1.6016
5	-0.0195	-0.3174	-5.2051	-2.71	55	0.0586	-0.1709	1.2988	0.5566	105	-0.4443	0.2979	1.3721	-1.5674	155	-0.4004	0.2393	1.3721	-1.1426
6	-0.127	-0.3174	1.4648	-1.9189	56	0.293	-0.2295	1.4258	0.5518	106	-0.4395	0.249	-4.2871	-2.3828	156	-0.415	0.293	0.1758	-0.3516
7	-0.2637	-0.293	-1.6357	-1.333	57	0.3125	-0.2686	1.4746	0.6738	107	-0.415	0.1709	1.3867	-1.5576	157	-0.4492	0.332	1.3574	-0.1172
8	-0.1855	-0.2637	1.4502	-0.9814	58	0.0928	-0.3027	1.4355	0.6299	108	-0.376	0.0928	0.957	-0.4736	158	-0.4688	0.3516	1.3672	0.3369
9	-0.332	-0.21	-0.2246	-0.4785	59	-0.1025	-0.3223	1.4893	0.7031	109	-0.293	-0.0146	1.4014	-0.249	159	-0.4639	0.3564	1.3477	0.4395
10	-0.3027	-0.1514	1.4209	-0.3711	60	-0.1563	-0.3271	-9.7803	-2.793	110	-0.1563	-0.0977	1.4307	0.2588	160	-0.4492	0.3369	1.3867	0.5908
11	-0.3125	-0.0684	1.2549	0.2539	61	-0.0195	-0.3271	1.4844	-1.2354	111	0.0879	-0.1709	1.4209	0.2832	161	-0.4541	0.3027	-10	-3.252
12	-0.3418	0.0195	1.3965	0.2588	62	-0.1465	-0.3174	-4.2969	-2.2754	112	0.3613	-0.2197	1.46	0.5273	162	-0.4443	0.2441	1.3916	-1.8359
13	-0.3711	0.1172	1.4063	0.5469	63	-0.2686	-0.3027	1.4648	-1.6113	113	0.3467	-0.2832	1.4404	0.5225	163	-0.4492	0.1709	-2.2266	-1.6943
14	-0.3955	0.1855	1.3721	0.5566	64	-0.2148	-0.2637	-1.9043	-1.2939	114	0.1953	-0.3027	1.4893	0.6641	164	-0.3809	0.083	1.3965	-1.0303
15	-0.4102	0.2637	1.3965	0.6689	65	-0.3174	-0.2148	1.4404	-0.9424	115	-0.0293	-0.3369	1.4453	0.6104	165	-0.332	-0.0146	1.3525	-0.166
16	-0.4346	0.3125	-8.916	-2.5244	66	-0.3174	-0.1563	-0.4736	-0.5518	116	-0.0977	-0.3369	1.4893	0.7031	166	-0.1855	-0.1025	1.4209	0
17	-0.4492	0.3613	1.3721	-1.748	67	-0.3174	-0.0732	1.4209	-0.332	117	0.0293	-0.3418	-8.8867	-2.5342	167	0.0195	-0.166	1.4355	0.3564
18	-0.4395	0.3711	-1.9141	-1.2744	68	-0.332	0.0244	1.3867	0.249	118	-0.0732	-0.3271	1.4893	-1.084	168	0.3076	-0.2295	1.4307	0.3906
19	-0.4639	0.376	1.3672	-0.7129	69	-0.3516	0.1074	1.3916	0.3711	119	-0.2686	-0.3076	-4.2139	-2.1777	169	0.3516	-0.2783	1.4551	0.5371
20	-0.4541	0.3418	1.3477	0.0098	70	-0.3906	0.1904	1.3916	0.5566	120	-0.1758	-0.2637	1.4746	-1.5625	170	0.2002	-0.3076	1.4648	0.5859
21	-0.459	0.3125	1.3672	0.2783	71	-0.4053	0.2539	1.3623	0.6055	121	-0.3271	-0.2148	-2.251	-1.3623	171	0	-0.332	1.4795	0.6494
22	-0.4297	0.249	1.377	0.4541	72	-0.4541	0.3125	1.3672	0.6348	122	-0.3223	-0.1514	1.4453	-0.9717	172	-0.0781	-0.3418	1.46	0.6494
23	-0.4102	0.1807	-8.1592	-2.4756	73	-0.4443	0.3467	-6.5137	-1.7676	123	-0.3223	-0.083	-0.3809	-0.5469	173	0	-0.3418	1.4746	0.6689
24	-0.3662	0.0928	1.3867	-1.1426	74	-0.4492	0.3662	1.3525	-1.2939	124	-0.332	0.0146	1.4453	-0.2393	174	-0.0244	-0.332	-7.3682	-2.041
25	-0.3027	0	-5.9766	-2.6416	75	-0.4541	0.3613	-0.8057	-0.6885	125	-0.3662	0.0879	1.3721	0.2344	175	-0.2832	-0.3027	1.4648	-0.8545
26	-0.1904	-0.0977	1.4063	-1.9727	76	-0.459	0.3369	1.3574	-0.3516	126	-0.4053	0.1709	1.3916	0.4395	176	-0.1514	-0.2588	-3.7744	-1.8701
27	0.0195	-0.1563	-3.0762	-1.7236	77	-0.4346	0.2979	1.3721	0.2246	127	-0.4102	0.2295	1.3672	0.5176	177	-0.332	-0.2002	1.4404	-1.4111
28	0.2783	-0.2148	1.4307	-1.3184	78	-0.4346	0.2393	1.3623	0.3857	128	-0.4443	0.293	-10	-3.7256	178	-0.2979	-0.1465	-2.1094	-1.2012
29	0.3564	-0.2637	-0.8789	-0.791	79	-0.4004	0.1709	1.4014	0.5371	129	-0.4443	0.3271	1.3477	-1.8408	179	-0.3271	-0.0635	1.4209	-0.8594
30	0.1904	-0.3027	1.4502	-0.5664	80	-0.4053	0.083	-10	-3.5938	130	-0.4541	0.3564	-4.6826	-2.6563	180	-0.3418	0.0244	0.3662	-0.2539
31	-0.0879	-0.3174	1.4648	0.1953	81	-0.3223	-0.0098	1.4014	-1.7285	131	-0.459	0.3516	1.3477	-1.7773	181	-0.376	0.1074	1.4063	-0.0391
32	-0.1807	-0.3271	1.4502	0.2197	82	-0.2295	-0.1074	-6.0303	-3.0615	132	-0.4492	0.332	0.4883	-0.6738	182	-0.3857	0.1807	1.3916	0.3467
33	-0.0244	-0.3223	1.499	0.5225	83	-0.0244	-0.1709	1.4355	-1.5234	133	-0.459	0.293	1.3477	-0.3271	183	-0.415	0.249	1.3721	0.4785
34	-0.1123	-0.3174	1.4404	0.5176	84	0.2246	-0.2295	-3.5693	-2.1973	134	-0.4346	0.2441	1.3916	0.1953	184	-0.4297	0.2979	1.4111	0.5762
35	-0.2783	-0.293	1.4893	0.6689	85	0.3516	-0.2832	1.4453	-1.5771	135	-0.415	0.1709	1.3574	0.3125	185	-0.4541	0.3418	-10	-2.9834
36	-0.166	-0.2637	1.416	0.6006	86	0.2148	-0.3174	-0.8789	-0.9814	136	-0.3955	0.083	1.416	0.5078	186	-0.4395	0.3564	1.3623	-2.0654
37	-0.3174	-0.2002	1.4697	0.7178	87	-0.0146	-0.332	1.4697	-0.6348	137	-0.3418	-0.0098	-10	-3.0225	187	-0.4492	0.3711	-2.5	-1.5918
38	-0.293	-0.1563	1.3965	0.6348	88	-0.1855	-0.3369	1.46	0.1025	138	-0.2246	-0.0977	1.4258	-1.3672	188	-0.4492	0.3516	1.3623	-0.9814
39	-0.3125	-0.0684	1.4355	0.7227	89	-0.0977	-0.3369	1.46	0.1807	139	-0.0488	-0.166	-6.2793	-2.9736	189	-0.4346	0.3174	1.3623	-0.083
40	-0.3516	0.0146	-10	-2.9443	90	-0.1221	-0.3271	1.4746	0.459	140	0.21	-0.2246	1.4551	-1.4014	190	-0.4346	0.2588	1.3672	0.1563
41	-0.3662	0.1074	1.4209	-1.3037	91	-0.2344	-0.3076	1.4453	0.4932	141	0.3467	-0.2734	-3.6328	-2.207	191	-0.415	0.1953	1.4014	0.4297
42	-0.4004	0.1758	-2.4512	-1.7383	92	-0.1953	-0.2637	1.46	0.6299	142	0.2197	-0.3076	1.4697	-1.499	192	-0.3564	0.0928	1.377	0.4736
43	-0.4004	0.249	1.3818	-0.9863	93	-0.3076	-0.2197	1.4307	0.6104	143	-0.0146	-0.332	-0.2881	-0.8252	193	-0.2881	0.0098	1.416	0.5859
44	-0.415	0.3027	1.3477	-0.1611	94	-0.2832	-0.1563	1.4355	0.6885	144	-0.1855	-0.3369	1.4795	-0.4492	194	-0.1709	-0.0977	-9.1699	-2.6807
45	-0.4395	0.3418	1.377	0.1709	95	-0.332	-0.083	1.4014	0.6445	145	-0.0879	-0.3418	1.4551	0.1221	195	0.0488	-0.1563	1.4355	-1.1865
46	-0.4492	0.3613	1.3574	0.3955	96	-0.3564	0.0146	1.4014	0.6982	146	-0.0977	-0.3223	1.4648	0.2637	196	0.2979	-0.2295	-6.3428	-2.876
47	-0.459	0.3613	1.3525	0.5371	97	-0.3516	0.0928	-9.458	-2.6758	147	-0.2686	-0.3027	1.4551	0.4346	197	0.3564	-0.2637	1.46	-1.4697
48	-0.459	0.3369	1.3525	0.5615	98	-0.3955	0.1758	1.3965	-1.8555	148	-0.1904	-0.2539	1.4502	0.5273	198	0.1953	0.3125	-2.5586	-1.8115
49	-0.4492	0.2979	-6.1328	-1.665	99	-0.3955	0.2393	-1.4844	-1.2012	149	-0.3027	-0.2051	1.4307	0.5908	199	-0.127	-0.3271	1.4795	-1.167
50	-0.4297	0.2393	1.3721	-1.1865	100	-0.4248	0.3027	1.3721	-0.6445	150	-0.2832	-0.1416	1.4258	0.6396	200	-0.1611	-0.3418	1.0156	-0.3174



Waktu 20 detik  
 Tinggi Gel 2 cm  
 Periode 1.5 dt

No	Load cell (Volt)	Seasim (Volt)	Trimmer 1 (Volt)	Trimmer 2 (Volt)	No	Load cell (Volt)	Seasim (Volt)	Trimmer 1 (Volt)	Trimmer 2 (Volt)	No	Load cell (Volt)	Seasim (Volt)	Trimmer 1 (Volt)	Trimmer 2 (Volt)	No	Load cell (Volt)	Seasim (Volt)	Trimmer 1 (Volt)	Trimmer 2 (Volt)	No	Load cell (Volt)	Seasim (Volt)	Trimmer 1 (Volt)	Trimmer 2 (Volt)
1	-0.0439	-0.332	1.4453	0.6445	51	0.0244	0.1172	1.4258	-0.5273	101	-0.4395	0.249	1.3281	0.6055	151	-0.166	-0.3369	1.4746	0.6934					
2	-0.3271	-0.332	1.4502	0.6299	52	0.3467	0.0244	-10	-0.0625	102	-0.4639	0.3125	1.377	0.7031	152	-0.3076	-0.3174	1.4258	0.6641					
3	-0.2344	-0.3076	-1.7383	-0.4297	53	0.4346	-0.0781	1.46	-2.0068	103	-0.4688	0.3516	-10	-3.0664	153	-0.2441	-0.293	1.4502	0.6934					
4	-0.3271	-0.2881	1.4307	0.0244	54	0.3174	-0.1514	-9.1699	-4.1699	104	-0.4541	0.3809	1.377	-1.3623	154	-0.2979	-0.2588	1.4014	0.6592					
5	-0.3418	-0.2295	-10	-3.7402	55	0.0342	-0.2148	1.4795	-2.1338	105	-0.4492	0.3906	-4.6729	-2.4463	155	-0.3516	-0.21	1.4453	0.6885					
6	-0.3516	-0.1855	1.4014	-1.8555	56	0.1904	-0.2637	-3.7402	-2.6025	106	-0.4395	0.3809	1.3867	-1.5674	156	-0.3516	-0.1563	-10	-3.3936					
7	-0.4053	-0.1074	-5.5713	-2.9639	57	0.4688	-0.3076	1.4795	-1.7578	107	-0.4199	0.3516	0.0977	-0.7324	157	-0.4053	-0.083	1.4014	-1.6064					
8	-0.4102	-0.0293	1.377	-2.041	58	0.1904	-0.332	0.2393	-0.7861	108	-0.3955	0.3125	1.4063	-0.3418	158	-0.4102	0.0098	-4.751	-2.6025					
9	-0.415	0.0781	-0.835	-1.1768	59	-0.0977	-0.3467	1.4746	-0.498	109	-0.3125	0.249	1.3965	0.1709	159	-0.415	0.1025	1.3721	-1.7627					
10	-0.415	0.1611	1.3525	-0.7568	60	-0.0342	-0.3516	1.5088	0.1611	110	-0.1709	0.1807	1.4258	0.2539	160	-0.4297	0.1904	-0.8252	-1.0693					
11	-0.4346	0.2539	1.333	0.0293	61	-0.2197	-0.3467	1.4502	0.1416	111	0.0879	0.0928	1.4307	0.4932	161	-0.4541	0.2637	1.3574	-0.6592					
12	-0.4492	0.3125	1.3525	0.1123	62	-0.3076	-0.3369	1.4551	0.4736	112	0.4004	0.0098	1.4502	0.4736	162	-0.4541	0.3125	1.25	0.0293					
13	-0.459	0.3711	1.3525	0.4541	63	-0.2539	-0.3174	1.4209	0.3271	113	0.4248	-0.0977	1.4648	0.6104	163	-0.4541	0.3516	1.3574	0.1514					
14	-0.459	0.3955	1.3477	0.5029	64	-0.3027	-0.2734	1.4307	0.5957	114	0.2344	-0.1563	1.4746	0.6543	164	-0.4443	0.3711	1.3574	0.4346					
15	-0.4541	0.415	1.3672	0.6494	65	-0.3174	-0.2295	1.3818	0.4492	115	0.0977	-0.2246	1.4844	0.6641	165	-0.4248	0.3809	1.3672	0.5371					
16	-0.4443	0.4053	1.3525	0.6348	66	-0.3564	-0.1709	1.416	0.6445	116	0.2637	-0.2637	1.4844	0.7129	166	-0.4346	0.3711	1.377	0.6152					
17	-0.4102	0.3857	1.3818	0.7031	67	-0.4053	-0.1074	1.3818	0.6006	117	0.4785	-0.3076	1.5088	0.6982	167	-0.415	0.3467	1.3672	0.6543					
18	-0.4199	0.3369	-8.252	-2.2852	68	-0.4004	-0.0098	1.3965	0.6982	118	0.1807	-0.3223	-10	-3.54	168	-0.3955	0.3076	1.3867	0.6641					
19	-0.3223	0.2783	1.4111	-0.9473	69	-0.4199	0.083	-3.5059	-0.9912	119	-0.0928	-0.3516	1.4844	-1.7139	169	-0.2979	0.2539	-9.4482	-2.6416					
20	-0.2246	0.2051	-5.5029	-2.4365	70	-0.4443	0.1709	1.377	-0.2197	120	-0.0195	-0.3369	-7.3193	-3.4131	170	-0.1563	0.1904	1.416	-1.2012					
21	0	0.127	1.4355	-1.0889	71	-0.4443	0.2441	-8.2764	-2.8662	121	-0.2295	-0.3467	1.4551	-1.7236	171	0.0098	0.1074	-8.5986	-3.4912					
22	0.3076	0.0293	-4.9902	-2.3828	72	-0.4639	0.3076	1.3623	-1.4258	122	-0.3125	-0.3223	-6.4453	-3.1885	172	0.3467	0.0244	1.4502	-1.7285					
23	0.459	-0.0635	1.4648	-1.7188	73	-0.4639	0.3516	-3.6721	-2.1338	123	-0.2588	-0.3027	1.4648	-1.6113	173	0.4004	-0.0732	-6.9727	-3.3301					
24	0.3662	-0.1465	-2.5488	-1.5039	74	-0.4541	0.3857	1.3721	-1.4014	124	-0.3174	-0.2539	-6.1816	-3.0518	174	0.2393	-0.1465	1.4648	-1.6748					
25	0.0928	-0.2051	1.4893	-1.0059	75	-0.4395	0.3955	-0.1025	-0.6885	125	-0.3174	-0.2148	1.4063	-2.0215	175	0.0928	-0.2051	-2.8711	-2.0654					
26	0.1514	-0.2686	0.8008	-0.2344	76	-0.4492	0.3906	1.377	-0.293	126	-0.3418	-0.1514	-3.042	-1.9336	176	0.1563	-0.2539	1.4844	-1.4258					
27	0.3662	-0.3027	1.4844	-0.0391	77	-0.4346	0.3662	1.3721	0.1904	127	-0.3809	-0.0879	1.3916	-1.3184	177	0.3613	-0.2881	0.7275	-0.4639					
28	0.2637	-0.3271	1.4941	0.3516	78	-0.3809	0.3223	1.4014	0.4004	128	-0.4004	0.0146	0.7959	-0.4004	178	0.21	-0.3174	1.4746	-0.2637					
29	-0.0977	-0.3418	1.4746	0.4492	79	-0.2979	0.2637	1.4111	0.5322	129	-0.4248	0.1074	1.3623	-0.1855	179	-0.1514	-0.3271	1.4893	0.2734					
30	-0.0928	-0.3467	1.3379	0.5029	80	-0.1758	0.1904	1.4209	0.6299	130	-0.4346	0.1953	1.3574	0.2686	180	-0.1025	-0.332	1.4502	0.2783					
31	-0.1367	-0.3418	1.4502	0.5664	81	0.0391	0.1025	1.4355	0.6592	131	-0.4297	0.2588	1.333	0.3516	181	-0.2246	-0.3271	1.4697	0.5078					
32	-0.293	-0.3369	1.4551	0.6396	82	0.376	0.0146	1.4502	0.7129	132	-0.4736	0.3174	1.3477	0.5566	182	-0.2979	-0.3174	1.4307	0.4297					
33	-0.2393	-0.3223	1.4258	0.6348	83	0.4639	-0.0928	1.4551	0.7031	133	-0.4639	0.3516	1.3428	0.5664	183	-0.249	-0.2881	1.4453	0.6104					
34	-0.2979	-0.2832	1.4307	0.6787	84	0.293	-0.1611	1.4746	0.7422	134	-0.4639	0.3809	1.3818	0.6592	184	-0.3125	-0.2539	1.4014	0.5029					
35	-0.3369	-0.2344	1.3965	0.6592	85	0.1611	-0.2246	1.5186	0.7227	135	-0.4395	0.3857	-10	-3.7012	185	-0.3223	-0.2051	1.4209	0.6396					
36	-0.3467	-0.1758	1.4111	0.6885	86	0.2246	-0.2686	-10	-3.0566	136	-0.4492	0.376	1.3721	-1.748	186	-0.3613	-0.1514	1.3867	0.5859					
37	-0.415	-0.1074	-10	-3.1836	87	0.4004	-0.3076	1.4746	-1.4502	137	-0.4297	0.3516	-5.4004	-2.876	187	-0.3906	-0.083	1.4063	0.6885					
38	-0.4053	-0.0195	1.4014	-1.4893	88	0.2197	-0.3271	-4.751	-2.4609	138	-0.415	0.3076	1.4014	-1.9434	188	-0.415	0.0098	-10	-3.7012					
39	-0.4248	0.0732	-6.6357	-3.0908	89	-0.0586	-0.3467	1.4648	-1.7871	139	-0.3418	0.249	-1.5625	-1.3721	189	-0.4199	0.0977	1.3721	-1.7236					
40	-0.415	0.166	1.3721	-2.1582	90	-0.0488	-0.3467	-1.5332	-1.2256	140	-0.1807	0.1807	1.416	-0.9961	190	-0.4199	0.1807	-7.4219	-3.5059					
41	-0.4492	0.2441	-2.3193	-1.6406	91	-0.1904	-0.3516	1.4453	-0.9766	141	0.0781	0.0977	-0.9521	-0.7129	191	-0.4443	0.2539	1.3623	-2.373					
42	-0.4443	0.3174	1.3623	-1.0889	92	-0.2783	-0.3271	-0.8398	-0.6299	142	0.332	0.0049	1.4453	-0.5762	192	-0.4541	0.3027	-3.5352	-2.1777					
43	-0.4639	0.3613	0.4443	-0.3809	93	-0.249	-0.3125	1.4063	-0.6348	143	0.415	-0.0879	-0.0928	-0.2246	193	-0.4541	0.3467	1.3623	-1.4648					
44	-0.4639	0.3955	1.3574	-0.1514	94	-0.3174	-0.2637	-0.8447	-0.4199	144	0.2881	-0.1611	1.4697	-0.1367	194	-0.4541	0.3711	-0.5176	-0.8545					
45	-0.4443	0.4102	1.3525	0.2979	95	-0.3125	-0.2197	1.4941	-0.376	145	0.1318	-0.2197	1.4844	0.3906	195	-0.4346	0.3857	1.3721	-0.4395					
46	-0.4443	0.4053	1.4063	0.459	96	-0.3467	-0.1611	0.9082	0.1953	146	0.0781	-0.2637	1.4697	0.4053	196	-0.4248	0.376	1.3525	0.1172					
47	-0.4199	0.376	1.3818	0.5859	97	-0.3711	-0.0928	1.3721	0.166	147	0.3271	-0.3027	1.499	0.5859	197	-0.4199	0.3564	1.3965	0.3369					
48	-0.3809	0.332	1.3965	0.6348	98	-0.4004	0.0049	1.4014	0.5176	148	0.2246	-0.3271	1.4697	0.6104	198	-0.4053	0.3174	1.3867	0.4932					
49	-0.3174	0.2686	1.416	0.6889	99	-0.4004	0.0928	1.3477	0.5127	149	-0.1514	-0.3369	1.499	0.6738	199	-0.2881	0.2637	1.416	0.6104					
50	-0.2002	0.2002	-5.2148	-1.4697	100	-0.4443	0.1807	1.3818	0.6592	150	-0.1465	-0.3418	1.4551	0.6592	200	-0.1904	0.1904	1.4111	0.625					



Tinggi Gel 2 cm  
 Periode 1.6 dt

No	Load cell (Volt)	Seasim (Volt)	Trimmeter 1 (Volt)	Trimmeter 2 (Volt)	No	Load cell (Volt)	Seasim (Volt)	Trimmeter 1 (Volt)	Trimmeter 2 (Volt)	No	Load cell (Volt)	Seasim (Volt)	Trimmeter 1 (Volt)	Trimmeter 2 (Volt)	No	Load cell (Volt)	Seasim (Volt)	Trimmeter 1 (Volt)	Trimmeter 2 (Volt)	No	Load cell (Volt)	Seasim (Volt)	Trimmeter 1 (Volt)	Trimmeter 2 (Volt)
1	-0.3613	0.2979	1.4258	0.6396	51	-0.2197	-0.332	1.5186	0.752	101	-0.3027	0.459	1.3867	0.7275	151	-0.2734	-0.3467	1.3965	0.5664					
2	-0.3418	0.3516	-10	-3.6426	52	-0.0732	-0.3418	1.4307	0.6592	102	-0.2686	0.4541	1.3916	0.7324	152	-0.2979	-0.3174	1.4209	0.5225					
3	-0.3418	0.4102	1.3574	-1.6846	53	-0.2539	-0.3516	1.5723	0.7617	103	-0.2051	0.4248	1.416	0.7617	153	-0.2539	-0.2881	1.3672	0.5908					
4	-0.3125	0.4297	-8.6914	-3.8428	54	-0.2295	-0.3467	1.4111	0.6641	104	-0.0244	0.3809	1.4258	0.7617	154	-0.3027	-0.2344	1.3965	0.6396					
5	-0.3369	0.4492	1.3965	-1.8604	55	-0.2148	-0.3418	1.4746	0.7324	105	0.2832	0.3174	1.4551	0.7813	155	-0.3076	-0.1904	1.3525	0.625					
6	-0.2539	0.4346	-4.2871	-2.6221	56	-0.2246	-0.3223	1.3867	0.6445	106	0.6592	0.2441	1.4502	0.7813	156	-0.3174	-0.1172	1.3721	0.6641					
7	-0.1855	0.4248	1.4063	-1.8701	57	-0.2734	-0.293	1.4063	0.7031	107	0.625	0.1514	1.4795	0.7959	157	-0.3271	-0.0293	1.3379	0.6299					
8	-0.0293	0.376	-4.292	-2.085	58	-0.2734	-0.249	-9.9902	-2.8711	108	0.4053	0.0635	1.4844	0.7959	158	-0.3369	0.0684	1.3477	0.6738					
9	0.2686	0.332	1.4551	-0.8838	59	-0.3076	-0.1953	1.3818	-1.2891	109	0.6299	-0.0391	1.5137	0.7861	159	-0.3418	0.1465	1.3477	0.6494					
10	0.6494	0.2539	-4.5166	-2.124	60	-0.3369	-0.1318	-5.5518	-2.6953	110	0.9814	-0.1221	-10	-2.7637	160	-0.3516	0.2295	1.3477	0.6934					
11	0.6738	0.1807	1.4844	-1.5332	61	-0.3369	-0.0293	1.3623	-1.9287	111	0.9473	-0.1855	1.5039	-1.25	161	-0.3564	0.2979	1.3379	0.6592					
12	0.6689	0.0781	-1.7725	-1.1475	62	-0.3467	0.0684	-3.8379	-1.9971	112	0.6787	-0.2344	-4.6729	-2.334	162	-0.3418	0.3564	-10	-3.5986					
13	0.6445	-0.0098	1.499	-0.7129	63	-0.3418	0.1563	1.3477	-1.4893	113	0.6348	-0.2783	1.4941	-1.6748	163	-0.3516	0.4053	1.3428	-1.7432					
14	0.9473	-0.1172	1.2158	0.0195	64	-0.3418	0.2393	-2.8467	-1.4648	114	0.0684	-0.3027	-1.3965	-1.1279	164	-0.3369	0.4395	-9.0771	-3.9209					
15	1.1084	-0.1758	1.5088	0.166	65	-0.3369	0.3076	1.377	-1.0645	115	-0.1904	-0.332	1.4893	-0.874	165	-0.3564	0.4492	1.3672	-2.002					
16	0.7275	-0.2344	1.5039	0.4541	66	-0.3516	0.3662	-1.1475	-0.7666	116	0.0781	-0.3467	-0.8008	-0.5859	166	-0.3174	0.4443	-3.7988	-2.4902					
17	0.5176	-0.2686	1.499	0.5615	67	-0.3369	0.4102	1.377	-0.459	117	-0.2637	-0.3564	1.4453	-0.625	167	-0.3076	0.4199	1.3867	-1.7627					
18	0.2734	-0.3076	1.4941	0.5859	68	-0.3418	0.4443	1.2598	0.1758	118	-0.2295	-0.3467	-1.9336	-0.7324	168	-0.2588	0.3711	-1.3867	-1.1865					
19	-0.1904	-0.3223	1.4795	0.6592	69	-0.2686	0.459	1.3916	0.2783	119	-0.2637	-0.3467	1.4111	-0.7373	169	-0.1611	0.3076	1.4111	-0.9619					
20	-0.1221	-0.3467	1.4551	0.6543	70	-0.2393	0.4492	1.3867	0.5127	120	-0.2881	-0.3174	-1.3916	-0.6055	170	-0.0293	0.2344	-1.5283	-0.7959					
21	-0.2344	-0.3369	1.4502	0.6885	71	-0.1758	0.4248	1.4209	0.5322	121	-0.249	-0.293	1.3916	-0.4785	171	0.1465	0.1465	1.4307	-0.791					
22	-0.21	-0.3467	1.4307	0.6738	72	-0.0391	0.3857	1.4502	0.6494	122	-0.2686	-0.2393	1.0352	0.1465	172	0.3125	0.0537	-2.4463	-0.9131					
23	-0.2051	-0.332	1.4258	0.6934	73	0.2686	0.3174	1.4453	0.5908	123	-0.2881	-0.1953	1.3574	0.1221	173	0.3418	-0.0488	1.4453	-0.918					
24	-0.2197	-0.3223	1.3965	0.6738	74	0.7178	0.249	1.46	0.7129	124	-0.3271	-0.1172	1.3574	0.4688	174	0.0732	-0.127	-3.0908	-1.1475					
25	-0.2832	-0.2832	1.3965	0.6982	75	0.5908	0.1611	1.4795	0.6982	125	-0.3418	-0.0342	1.3672	0.4004	175	-0.1416	-0.1855	1.46	-1.0986					
26	-0.293	-0.2539	1.3867	0.6592	76	0.4688	0.0635	1.4941	0.7373	126	-0.3467	0.0684	1.3525	0.5957	176	-0.1953	-0.2344	-3.9453	-1.4746					
27	-0.3174	-0.1953	-10	-3.6279	77	0.7324	-0.0342	1.499	0.7666	127	-0.3564	0.1416	1.3379	0.5225	177	-0.1465	-0.2734	1.4355	-0.6348					
28	-0.3223	-0.1367	1.3428	-1.792	78	1.0986	-0.1221	1.5137	0.7764	128	-0.3564	0.2344	1.3574	0.6934	178	-0.2002	-0.3125	-5.5078	-2.2363					
29	-0.3418	-0.0391	-10	-4.4775	79	0.9814	-0.1855	1.4893	0.7715	129	-0.3369	0.293	1.333	0.625	179	-0.1807	-0.3369	1.4209	-1.0693					
30	-0.3418	0.0537	1.3232	-2.3389	80	0.7715	-0.2295	1.499	0.752	130	-0.3662	0.3662	1.3672	0.7422	180	-0.2002	-0.3516	-6.0791	-2.6807					
31	-0.3516	0.1563	-9.3213	-4.3994	81	0.6982	-0.2734	-8.7061	-2.3779	131	-0.3418	0.4053	1.3477	0.6738	181	-0.2441	-0.3613	1.3965	-1.4355					
32	-0.3613	0.2295	1.333	-2.3047	82	0.0439	-0.3076	1.4844	-1.0449	132	-0.3369	0.4443	1.416	0.7813	182	-0.249	-0.3613	-3.5938	-2.0703					
33	-0.3516	0.3125	-7.9443	-3.96	83	-0.1611	-0.3369	-5.3955	-2.4512	133	-0.3271	0.4492	-10	-3.5742	183	-0.2637	-0.3516	1.377	-1.499					
34	-0.3467	0.3613	1.3281	-2.0703	84	0.1123	-0.3467	1.4648	-1.1572	134	-0.249	0.4492	1.416	-1.6309	184	-0.2881	-0.3271	-0.4297	-0.8154					
35	-0.3516	0.415	-4.6094	-2.7783	85	-0.2441	-0.3516	-6.0059	-2.7295	135	-0.1758	0.415	-10	-4.4092	185	-0.3125	-0.2881	1.3477	-0.6201					
36	-0.3369	0.4395	1.3525	-1.9482	86	-0.1953	-0.3516	1.4258	-1.3281	136	0.0537	0.376	1.4502	-2.1533	186	-0.3174	-0.2441	0.6299	-0.1025					
37	-0.3516	0.459	-0.874	-1.1328	87	-0.2832	-0.3418	-7.2119	-3.208	137	0.4004	0.3076	-10	-5.1855	187	-0.3467	-0.1904	1.3232	-0.1855					
38	-0.2832	0.4443	1.377	-0.791	88	-0.2881	-0.3223	1.4063	-1.6064	138	0.7373	0.2393	1.4844	-2.5928	188	-0.3467	-0.1172	0.249	0.0439					
39	-0.2246	0.4248	0.5859	-0.1611	89	-0.249	-0.2881	-4.2969	-2.4902	139	0.6689	0.1514	-8.96	-4.5264	189	-0.3418	-0.0293	1.3086	-0.1416					
40	-0.0684	0.3809	1.3965	-0.2246	90	-0.2979	-0.2441	1.3721	-1.7578	140	0.5713	0.0684	1.5137	-2.2754	190	-0.3613	0.0684	-0.7275	-0.1514					
41	0.2441	0.3271	0.0781	0.0488	91	-0.3076	-0.1904	-0.9668	-1.1182	141	0.9473	-0.0342	-4.0039	-2.8369	191	-0.376	0.1465	1.2988	-0.3271					
42	0.6299	0.249	1.46	-0.083	92	-0.3174	-0.1172	1.3525	-0.7861	142	1.3623	-0.1172	1.5283	-1.8506	192	-0.3662	0.2295	-1.6748	-0.4736					
43	0.6641	0.1709	0.8105	0.3662	93	-0.3369	-0.0244	0.4199	-0.2588	143	1.0742	-0.1855	-0.1611	-1.001	193	-0.3711	0.3027	1.3232	-0.5518					
44	0.5225	0.0732	1.4746	0.2588	94	-0.3467	0.0684	1.3379	-0.2051	144	0.8936	-0.2295	1.5186	-0.5566	194	-0.3516	0.3613	-1.9727	-0.6396					
45	0.542	-0.0195	1.5186	0.6543	95	-0.3418	0.1563	0.9277	0.2051	145	0.6055	-0.2686	1.4893	0.0684	195	-0.3662	0.4102	1.3428	-0.5664					
46	0.8838	-0.1221	1.4795	0.5811	96	-0.3613	0.2393	1.333	0.1318	146	0.0098	-0.3076	1.499	0.21	196	-0.3516	0.4395	-0.2734	-0.1855					
47	1.0352	-0.1807	1.5332	0.7227	97	-0.3467	0.3076	1.2842	0.4932	147	-0.1172	-0.332	1.4551	0.4102	197	-0.3467	0.4541	1.3623	-0.0977					
48	0.6934	-0.2344	1.4795	0.6641	98	-0.3711	0.3662	1.3477	0.4053	148	0.0635	-0.3467	1.4795	0.4395	198	-0.3027	0.4492	1.377	0.4199					
49	0.5322	-0.2686	1.5186	0.7617	99	-0.3613	0.415	1.3574	0.6299	149	-0.2783	-0.3564	1.4258	0.5273	199	-0.2979	0.4199	1.3867	0.4248					
50	0.21	-0.3076	1.46	0.6787	100	-0.332	0.4492	1.3721	0.6299	150	-0.1611	-0.3516	1.4502	0.4541	200	-0.2783	0.3711	1.3965	0.6104					



Tinggi Gel 2 cm  
Periode 1.7 dt

No	Load cell (Volt)	Seasim (Volt)	Trimmeter 1 (Volt)	Trimmeter 2 (Volt)	No	Load cell (Volt)	Seasim (Volt)	Trimmeter 1 (Volt)	Trimmeter 2 (Volt)	No	Load cell (Volt)	Seasim (Volt)	Trimmeter 1 (Volt)	Trimmeter 2 (Volt)	No	Load cell (Volt)	Seasim (Volt)	Trimmeter 1 (Volt)	Trimmeter 2 (Volt)
1	0.5762	0.332	1.5088	0.7031	51	-0.4346	-0.3271	1.3916	0.625	101	0.5469	0.4346	-6.5967	-2.6758	151	-0.3906	-0.3564	1.416	0.708
2	1.1816	0.2441	-7.915	-2.168	52	-0.4346	-0.293	1.3477	0.6494	102	0.542	0.3857	1.4697	-1.2744	152	-0.4004	-0.3467	1.377	0.6348
3	1.7822	0.1611	1.5283	-0.8203	53	-0.4492	-0.2539	1.3672	0.6689	103	0.5176	0.3174	-4.3604	-2.2314	153	-0.4346	-0.3271	1.3965	0.6885
4	1.8701	0.0537	-5.166	-2.251	54	-0.4639	-0.2051	1.3281	0.6494	104	0.9912	0.2344	1.5088	-1.6602	154	-0.4541	-0.293	1.3379	0.6201
5	1.958	-0.0342	1.5332	-0.9326	55	-0.4736	-0.1318	1.3525	0.6641	105	1.5625	0.1465	-1.748	-1.1621	155	-0.4639	-0.2539	1.3623	0.6641
6	1.4941	-0.1416	-3.1201	-1.7334	56	-0.4883	-0.0488	1.3184	0.6592	106	1.6553	0.0488	1.5137	-0.8789	156	-0.4639	-0.2002	1.3232	0.6006
7	1.2402	-0.1904	1.5234	-1.2109	57	-0.4932	0.0537	1.3623	0.6787	107	1.7285	-0.0488	-0.0439	-0.3271	157	-0.4883	-0.1367	1.416	0.6787
8	0.3516	-0.2441	-0.957	-0.8105	58	-0.4785	0.1416	1.3379	0.6934	108	1.3184	-0.1318	1.5137	-0.2734	158	-0.498	-0.0537	1.3232	0.6201
9	-0.083	-0.2734	1.5234	-0.5518	59	-0.4932	0.2295	1.3721	0.7324	109	0.8887	-0.1953	1.3477	0.3467	159	-0.4932	0.0439	1.3574	0.6885
10	0.1465	-0.3076	-0.0977	-0.2783	60	-0.4932	0.2979	1.3477	0.7129	110	0.4297	-0.2393	1.4941	0.2344	160	-0.498	0.1367	1.3232	0.6396
11	-0.4053	-0.3174	1.4746	-0.3174	61	-0.4883	0.3662	1.3916	0.7617	111	-0.1172	-0.2734	1.499	0.5957	161	-0.4883	0.2148	1.3916	0.7129
12	-0.332	-0.3467	-1.8262	-0.6104	62	-0.4883	0.415	1.3818	0.7324	112	-0.2295	-0.3076	1.46	0.4053	162	-0.5078	0.2881	1.3379	0.6689
13	-0.4004	-0.3418	1.4404	-0.7178	63	-0.4199	0.459	1.4111	0.7861	113	-0.2197	-0.332	1.46	0.6494	163	-0.4785	0.3564	1.377	0.7324
14	-0.3662	-0.3516	-4.082	-1.3672	64	-0.2979	0.4834	1.4063	0.7617	114	-0.3809	-0.3467	1.4355	0.3174	164	-0.4492	0.4102	-10	-3.1152
15	-0.3955	-0.3418	1.4111	-1.1523	65	-0.1172	0.4932	1.4453	0.8154	115	-0.3223	-0.3516	0.3662	0.3613	165	-0.3955	0.4492	1.416	-1.3916
16	-0.4053	-0.3369	-2.9053	-1.2646	66	0.2344	0.4785	1.4355	0.8008	116	-0.3467	-0.3564	1.4063	0.0391	166	-0.2979	0.4688	-10	-4.4824
17	-0.4346	-0.3174	1.3867	-0.9424	67	0.6543	0.4492	1.4746	0.8496	117	-0.3857	-0.3564	-0.083	0.1611	167	-0.1025	0.4736	1.4307	-2.1973
18	-0.4443	-0.2979	-1.2451	-0.7764	68	0.6104	0.3906	1.4795	0.8301	118	-0.415	-0.3467	1.3818	0.0098	168	0.1758	0.459	1.4307	-1.0449
19	-0.4688	-0.249	1.3623	-0.6055	69	0.6006	0.332	1.5088	0.874	119	-0.4199	-0.3271	1.1133	0.4297	169	0.6055	0.4248	1.4893	-0.2979
20	-0.4639	-0.2051	-1.1377	-0.5908	70	1.1768	0.2441	1.5088	0.8398	120	-0.4492	-0.2979	1.3818	0.2539	170	0.6152	0.3711	1.4648	0.0781
21	-0.4736	-0.1367	1.3525	-0.5371	71	1.7578	0.1611	1.5283	0.874	121	-0.4541	-0.2539	1.3428	0.5762	171	0.6201	0.3076	1.5039	0.376
22	-0.4834	-0.0488	-1.8066	-0.7031	72	1.8408	0.0537	1.5479	0.8252	122	-0.4541	-0.2002	1.3379	0.3369	172	0.9277	0.2246	-10	-3.1934
23	-0.4834	0.0586	1.3525	-0.6396	73	1.9189	-0.0439	-10	-3.0664	123	-0.4785	-0.1367	1.3379	0.625	173	1.46	0.1318	1.5234	-1.4404
24	-0.4736	0.1416	-2.2266	-0.835	74	1.4502	-0.1318	1.5088	-1.4209	124	-0.4932	-0.0537	1.3281	0.3516	174	1.5967	0.0342	-7.3535	-3.2959
25	-0.4834	0.2344	1.3672	-0.6494	75	1.123	-0.1904	-8.5986	-3.5889	125	-0.4883	0.0439	1.2451	0.6396	175	1.5967	-0.0635	1.5234	-1.5771
26	-0.4639	0.3076	-1.0742	-0.5176	76	0.3271	-0.2393	1.4893	-1.8018	126	-0.4834	0.1318	1.3428	0.3809	176	1.2695	-0.1416	-4.6436	-2.583
27	-0.4639	0.376	1.3818	-0.3125	77	-0.127	-0.2686	-5.7324	-2.9883	127	-0.4883	0.21	1.3428	0.6885	177	0.7324	-0.2051	1.5234	-1.8555
28	-0.4443	0.4248	0.7861	0.1318	78	0.0195	-0.3076	1.4648	-1.5088	128	-0.4736	0.2881	1.3525	0.5127	178	0.5029	-0.2441	-2.1338	-1.4648
29	-0.4297	0.4688	1.4111	0.1465	79	-0.3711	-0.3271	-6.4551	-3.0518	129	-0.4785	0.3613	1.499	0.7666	179	-0.083	-0.2832	1.4941	-1.0889
30	-0.3223	0.4785	0.7813	0.3516	80	-0.3369	-0.3467	1.4258	-1.5527	130	-0.459	0.4102	1.377	0.6494	180	-0.332	-0.3125	-1.3623	-0.8936
31	-0.1709	0.4883	1.5479	0.21	81	-0.3662	-0.3516	-10	-4.3311	131	-0.4004	0.4443	1.416	0.7617	181	-0.0977	-0.3369	1.4648	-0.8447
32	0.1563	0.4736	-0.7031	0.0439	82	-0.3467	-0.3564	1.4063	-2.2656	132	-0.3418	0.4688	1.4063	0.6348	182	-0.3857	-0.3516	-3.6035	-1.3574
33	0.6055	0.4443	1.4746	-0.0488	83	-0.3857	-0.3467	-10	-4.9902	133	-0.1221	0.4785	1.4453	0.7861	183	-0.3467	-0.3613	1.4307	-0.5225
34	0.6641	0.3857	-0.415	0.0342	84	-0.3809	-0.3467	1.3721	-2.6709	134	0.2295	0.459	1.4453	0.5859	184	-0.4053	-0.3613	-5.874	-2.3389
35	0.5566	0.3271	1.5088	0.0781	85	-0.4248	-0.3271	-8.0518	-4.2432	135	0.6641	0.4248	1.4746	0.8203	185	-0.4053	-0.3564	1.4063	-1.084
36	1.04	0.249	1.2939	0.5176	86	-0.4395	-0.2979	1.3525	-2.2803	136	0.6494	0.3662	1.4746	0.6641	186	-0.4004	-0.3467	-4.3359	-2.207
37	1.6504	0.166	1.5332	0.4785	87	-0.4688	-0.2539	-6.5576	-3.5547	137	0.7031	0.3076	1.5088	0.8398	187	-0.4297	-0.3271	1.377	-1.6504
38	1.6553	0.0586	1.5039	0.6982	88	-0.4688	-0.2051	1.3379	-1.8896	138	1.2061	0.2246	1.4941	0.7666	188	-0.4541	-0.293	-2.4658	-1.4697
39	1.792	-0.0391	1.5283	0.6689	89	-0.4785	-0.1367	-7.1484	-3.501	139	1.8311	0.1367	1.543	0.835	189	-0.459	-0.2539	1.3574	-1.1719
40	1.2939	-0.1318	1.5088	0.7324	90	-0.498	-0.0586	1.3232	-1.8359	140	1.8896	0.0391	1.5039	0.7764	190	-0.4688	-0.2002	-2.3096	-1.1816
41	0.9033	-0.1855	1.5234	0.752	91	-0.4785	0.0391	-8.2471	-3.7891	141	1.9922	-0.0635	1.543	0.8545	191	-0.4834	-0.1367	1.2305	-1.0742
42	0.3662	-0.2393	1.499	0.7129	92	-0.4883	0.127	1.333	-1.9824	142	1.4941	-0.1416	1.5088	0.7813	192	-0.4883	-0.0488	-3.0371	-1.2988
43	-0.166	-0.2686	1.5039	0.7568	93	-0.4834	0.2148	-7.793	-3.7305	143	1.1377	-0.2002	1.5332	0.835	193	-0.4932	0.0439	1.3477	-1.1279
44	-0.249	-0.3027	1.4648	0.7324	94	-0.4883	0.2881	1.3525	-1.9336	144	0.3467	-0.2441	1.4893	0.7471	194	-0.4834	0.1367	-3.2617	-1.3477
45	-0.2539	-0.3223	1.4697	0.7373	95	-0.4736	0.3613	-4.834	-2.7979	145	-0.1318	-0.2783	1.5576	0.8057	195	-0.4785	0.2148	1.3574	-1.084
46	-0.4053	-0.3467	1.4307	0.6641	96	-0.4443	0.415	1.377	-2.0605	146	-0.0488	-0.3076	1.4551	0.7178	196	-0.4834	0.293	-1.7969	-0.9082
47	-0.2832	-0.3467	1.4453	0.6006	97	-0.3955	0.4541	-3.0615	-1.7822	147	-0.3662	-0.332	1.499	0.7617	197	-0.4199	0.3564	1.3721	-0.6494
48	-0.3613	-0.3516	1.3916	0.6299	98	-0.2686	0.4785	1.4111	-1.4844	148	-0.3711	-0.3516	1.4209	0.6836	198	-0.4248	0.4053	0.1465	-0.1953
49	-0.4102	-0.3467	1.4209	0.5664	99	-0.1904	0.4834	-4.9072	-1.9727	149	-0.3271	-0.3564	1.4404	0.7324	199	-0.3662	0.4395	1.4209	-0.1611
50	-0.4102	-0.3467	1.3672	0.6201	100	0.1367	0.4688	1.4453	-0.8838	150	-0.3467	-0.3613	1.3965	0.6494	200	-0.3174	0.4639	-0.1367	-0.0293



Tinggi Gel 2 cm  
 Periode 1.8 dt

No	Load cell (Volt)	Seasim (Volt)	Trimmeter 1 (Volt)	Trimmeter 2 (Volt)	No	Load cell (Volt)	Seasim (Volt)	Trimmeter 1 (Volt)	Trimmeter 2 (Volt)	No	Load cell (Volt)	Seasim (Volt)	Trimmeter 1 (Volt)	Trimmeter 2 (Volt)	No	Load cell (Volt)	Seasim (Volt)	Trimmeter 1 (Volt)	Trimmeter 2 (Volt)
1	3.9014	0.3467	-2.3682	-0.4541	51	-0.3564	-0.3467	1.3867	0.459	101	-0.4492	0.3662	1.377	-2.3242	151	0.3467	-0.166	1.5039	-1.4209
2	3.9844	0.2832	1.5479	0.0928	52	-0.3711	-0.3467	1.3867	0.6738	102	-0.415	0.4102	-7.9834	-4.0381	152	-0.0244	-0.2197	-2.8271	-1.4746
3	3.7695	0.2148	-4.624	-1.4648	53	-0.3906	-0.3369	1.3574	0.5127	103	-0.3662	0.4443	1.4063	-2.002	153	-0.3369	-0.2588	1.4697	-1.3037
4	3.2422	0.127	1.543	-0.5176	54	-0.376	-0.3174	1.3574	0.6592	104	-0.3027	0.4541	-7.8564	-3.8184	154	-0.2051	-0.2832	-4.2822	-1.7139
5	2.3047	0.0391	-6.25	-2.3389	55	-0.4053	-0.3027	1.3379	0.5176	105	-0.166	0.459	1.4355	-1.8652	155	-0.3613	-0.3027	1.4307	-0.7813
6	1.4258	-0.0586	1.5234	-1.0596	56	-0.4053	-0.2686	1.3623	0.6494	106	0.1855	0.4443	-10	-5.0244	156	-0.3467	-0.3271	-7.8467	-3.042
7	0.4248	-0.1367	-4.8438	-2.2559	57	-0.4102	-0.2393	1.3281	0.5127	107	0.498	0.4199	1.4697	-2.5049	157	-0.3271	-0.3369	1.3965	-1.5332
8	-0.0635	-0.2002	1.4941	-1.2207	58	-0.4199	-0.1904	1.3623	0.6494	108	0.4639	0.3809	-10	-4.9268	158	-0.3027	-0.3418	-6.6748	-3.1348
9	-0.0391	-0.249	-3.8135	-1.9287	59	-0.4248	-0.1221	1.3379	0.5566	109	0.376	0.3223	1.5039	-2.4658	159	-0.3662	-0.3467	1.3574	-1.6309
10	-0.2734	-0.2783	1.4502	-0.9033	60	-0.4102	-0.0293	1.3721	0.7178	110	0.3467	0.2588	-10	-4.7705	160	-0.376	-0.3369	-5.7227	-2.9053
11	-0.2734	-0.2979	-7.1094	-2.8809	61	-0.4102	0.0635	1.3525	0.6396	111	0.6152	0.1855	1.5186	-2.3975	161	-0.4102	-0.3369	1.3184	-1.5186
12	-0.2979	-0.3174	1.416	-1.4355	62	-0.3857	0.1514	1.4063	0.752	112	0.8643	0.0977	-7.0264	-3.8232	162	-0.4199	-0.3174	-9.0869	-3.8721
13	-0.2979	-0.332	-9.2188	-3.8525	63	-0.4004	0.2344	1.3721	0.6787	113	0.5078	0.0146	1.5283	-1.8896	163	-0.4297	-0.2979	1.2891	-2.0459
14	-0.3516	-0.3467	1.3721	-2.002	64	-0.2979	0.3125	1.4404	0.7959	114	0.2979	-0.0879	-4.3848	-2.7441	164	-0.4346	-0.2588	-10	-5.3076
15	-0.3711	-0.3418	-6.8457	-3.4668	65	-0.21	0.3711	1.3965	0.7178	115	0.2344	-0.1563	1.5088	-1.9287	165	-0.4395	-0.2246	1.3623	-2.8125
16	-0.3857	-0.3467	1.333	-1.8311	66	0.0635	0.4248	1.4697	0.8252	116	-0.21	-0.2148	-3.4326	-1.958	166	-0.4492	-0.1709	1.2988	-1.4551
17	-0.4102	-0.332	-7.9932	-3.7207	67	0.5225	0.4492	1.4404	0.7373	117	-0.2051	-0.2539	1.4795	-0.8545	167	-0.4443	-0.1025	1.2939	-0.6982
18	-0.4248	-0.3223	1.3281	-1.958	68	0.8301	0.4688	1.5186	0.8447	118	-0.2197	-0.2783	-5.4248	-2.4414	168	-0.4492	0.0049	1.3086	-0.2197
19	-0.4395	-0.2979	-10	-5.2686	69	0.8301	0.459	1.4746	0.791	119	-0.2783	-0.3027	1.4551	-1.1182	169	-0.4443	0.0977	1.2988	0.1074
20	-0.4443	-0.2734	1.2891	-2.8125	70	1.6895	0.4492	1.543	0.918	120	-0.2637	-0.3271	-9.6582	-3.8965	170	-0.4492	0.1953	1.3232	0.2051
21	-0.4395	-0.2393	1.3037	-1.4551	71	2.8223	0.415	1.5137	0.8496	121	-0.2881	-0.332	1.4258	-1.9287	171	-0.4541	0.2588	1.3135	0.4004
22	-0.4443	-0.1904	1.2842	-0.7031	72	3.3936	0.376	1.5674	0.9521	122	-0.2979	-0.3467	-10	-4.8535	172	-0.4248	0.332	1.3428	0.3906
23	-0.4492	-0.1221	1.2939	-0.21	73	3.8135	0.3174	1.5234	0.8691	123	-0.332	-0.3418	1.4063	-2.4951	173	-0.4053	0.376	1.3574	0.5615
24	-0.4541	-0.0342	1.2891	0.083	74	4.0967	0.2637	1.5674	0.9082	124	-0.3564	-0.3418	-8.6328	-4.3994	174	-0.3711	0.4297	1.377	0.5859
25	-0.4492	0.0635	1.3086	0.2148	75	3.6963	0.1855	1.5479	0.8008	125	-0.3857	-0.3271	1.3818	-2.2803	175	-0.3711	0.4443	1.4063	0.6396
26	-0.4395	0.1465	1.3037	0.3809	76	3.0566	0.1172	1.5576	0.8789	126	-0.376	-0.3174	-6.2305	-3.5352	176	-0.2832	0.4639	1.4111	0.6348
27	-0.4443	0.2393	1.3281	0.3271	77	2.29	0.0146	1.5283	0.7373	127	-0.4004	-0.2832	1.3672	-1.8115	177	-0.1318	0.459	1.4258	0.6934
28	-0.4443	0.293	1.3232	0.5469	78	1.1572	-0.0732	1.543	0.835	128	-0.4053	-0.2686	-5.3516	-2.9883	178	0.1953	0.4541	1.4355	0.5811
29	-0.4297	0.3662	1.3574	0.4785	79	0.3662	-0.1611	1.5039	0.7422	129	-0.4199	-0.2197	1.3574	-2.168	179	0.5225	0.4199	1.4502	0.7422
30	-0.3955	0.4053	1.3672	0.6445	80	0.1367	-0.21	1.5137	0.7813	130	-0.4102	-0.1758	-4.541	-2.3926	180	0.4883	0.3809	1.4746	0.6104
31	-0.3662	0.4492	1.416	0.625	81	-0.2637	-0.2637	1.4697	0.7031	131	-0.4297	-0.0977	1.3672	-1.792	181	0.3467	0.3223	1.4844	0.7764
32	-0.3027	0.4639	1.416	0.7031	82	-0.2686	-0.2832	1.4697	0.7275	132	-0.4248	-0.0098	-2.666	-1.582	182	0.2832	0.2588	1.4893	0.6982
33	-0.1514	0.4736	1.4209	0.6006	83	-0.3076	-0.3125	1.4307	0.5566	133	-0.4199	0.0879	1.3818	-1.1475	183	0.5713	0.1758	1.5039	0.7861
34	0.1563	0.459	1.4307	0.7422	84	-0.2881	-0.3271	1.416	0.6885	134	-0.4004	0.166	-0.8252	-0.7617	184	0.7324	0.0928	1.4941	0.7568
35	0.4883	0.4395	1.4551	0.5371	85	-0.3027	-0.3369	1.3965	0.4883	135	-0.3662	0.2441	1.4014	-0.6055	185	0.4102	-0.0049	1.5088	0.7617
36	0.5566	0.3955	1.4307	0.7861	86	-0.3564	-0.3369	1.377	0.6641	136	-0.3174	0.3076	-1.1523	-0.5518	186	0.2539	-0.1025	1.4844	0.7422
37	0.3516	0.3418	1.4893	0.6006	87	-0.3711	-0.3418	1.3672	0.5273	137	-0.1953	0.3662	1.4307	-0.625	187	0.1807	-0.1758	1.4941	0.7764
38	0.2881	0.2734	1.4893	0.8203	88	-0.3809	-0.3369	1.3477	0.6396	138	0.1416	0.415	-3.3838	-1.0889	188	-0.2295	-0.2246	1.4697	0.7324
39	0.5371	0.2051	1.4941	0.7031	89	-0.3857	-0.332	1.3184	0.459	139	0.6299	0.4443	1.4648	-0.9473	189	-0.1904	-0.2637	1.4746	0.7617
40	0.7568	0.1221	1.5088	0.8105	90	-0.4297	-0.3174	1.2939	0.6006	140	0.8447	0.4541	-2.7783	-1.0498	190	-0.2734	-0.2881	1.4404	0.6885
41	0.4541	0.0342	1.499	0.752	91	-0.4297	-0.293	1.3135	0.2979	141	0.874	0.459	1.5088	-0.7861	191	-0.2881	-0.3174	1.4453	0.6885
42	0.2832	-0.0586	1.5039	0.7813	92	-0.4443	-0.2686	-0.293	0.1416	142	1.8604	0.4443	-0.8203	-0.4443	192	-0.2686	-0.332	1.4209	0.5469
43	0.2441	-0.1367	1.4795	0.7471	93	-0.4492	-0.2393	1.3037	-0.1416	143	2.7637	0.4199	1.5283	-0.4004	193	-0.2686	-0.3418	1.4063	0.6641
44	-0.2051	-0.1953	1.4893	-0.7715	94	-0.4541	-0.1855	-2.5928	-0.6689	144	3.5156	0.3711	-1.1572	-0.3418	194	-0.3076	-0.3467	1.3965	0.4883
45	-0.1904	-0.2441	1.46	0.7031	95	-0.4395	-0.1123	1.3037	-0.7764	145	3.96	0.3223	1.5479	-0.4736	195	-0.3369	-0.3516	1.4111	0.6641
46	-0.2002	-0.2783	1.4648	0.7178	96	-0.4395	-0.0098	-5.625	-1.8262	146	4.0186	0.2539	-3.0225	-0.8447	196	-0.3564	-0.3418	1.377	0.5371
47	-0.2881	-0.3027	1.4355	0.5469	97	-0.4541	0.0781	1.3184	-0.752	147	3.6572	0.1807	1.5381	-0.1758	197	-0.3564	-0.3369	1.3818	0.6445
48	-0.249	-0.3271	1.4209	0.6934	98	-0.4688	0.1709	-9.585	-3.5742	148	2.9443	0.0928	-4.9854	-1.7627	198	-0.3711	-0.3174	1.3574	0.5762
49	-0.293	-0.3369	1.4063	0.4248	99	-0.4834	0.249	1.3428	-1.7188	149	2.207	-0.0049	1.5332	-0.7275	199	-0.4004	-0.293	1.3721	0.6787
50	-0.3174	-0.3467	1.3867	0.6934	100	-0.4639	0.3125	-10	-4.6436	150	1.0059	-0.0928	-4.7314	-2.0361	200	-0.4053	-0.2637	1.3477	0.5957



Tinggi Gel 2 cm  
 Periode 1.9 dt

No	Load cell (Volt)	Seasim (Volt)	Trimmer 1 (Volt)	Trimmer 2 (Volt)	No	Load cell (Volt)	Seasim (Volt)	Trimmer 1 (Volt)	Trimmer 2 (Volt)	No	Load cell (Volt)	Seasim (Volt)	Trimmer 1 (Volt)	Trimmer 2 (Volt)	No	Load cell (Volt)	Seasim (Volt)	Trimmer 1 (Volt)	Trimmer 2 (Volt)
1	-0.3711	-0.3125	-10	-3.7158	51	1.6211	0.4443	1.5186	-0.8252	101	0.1123	0.0635	1.4844	0.7373	151	-0.3711	-0.3467	-0.8496	-0.0635
2	-0.3809	-0.2832	1.2598	-1.7773	52	2.7295	0.4932	-3.6426	-1.5576	102	-0.0146	-0.0488	1.5039	0.7373	152	-0.3711	-0.3418	1.2549	-0.2441
3	-0.3809	-0.2686	-10	-5.2002	53	3.7939	0.5273	1.543	-0.5762	103	0.0977	-0.1318	1.4746	0.7373	153	-0.376	-0.332	-0.6152	-0.1611
4	-0.3857	-0.2344	1.2598	-2.6758	54	4.9512	0.5469	-7.4658	-2.71	104	-0.2002	-0.2002	1.4697	0.7178	154	-0.3809	-0.3174	1.2451	-0.2686
5	-0.3711	-0.2051	-10	-5.7178	55	5.6543	0.5518	1.5625	-1.1963	105	-0.1172	-0.2344	1.4502	0.7178	155	-0.3857	-0.2881	-0.2783	-0.1074
6	-0.3711	-0.1367	1.2695	-2.9736	56	6.0742	0.542	1.5674	-0.3369	106	-0.2441	-0.2686	1.4502	0.7178	156	-0.376	-0.2588	1.2354	-0.21
7	-0.3613	-0.0537	-10	-5.7861	57	6.0303	0.5127	1.5674	0.1318	107	-0.2197	-0.2832	1.4258	0.6445	157	-0.3809	-0.2148	0.1709	0.0488
8	-0.3906	0.0537	1.2939	-3.0322	58	5.5908	0.4736	1.5674	0.4443	108	-0.2197	-0.3125	1.4209	0.6543	158	-0.3809	-0.1563	1.25	-0.0732
9	-0.3857	0.1416	1.1426	-1.709	59	4.6143	0.415	1.5625	0.5615	109	-0.2246	-0.3271	1.416	0.498	159	-0.3662	-0.0684	0.6299	0.2393
10	-0.3906	0.2393	1.3184	-0.7422	60	3.4863	0.3467	1.5576	0.6348	110	-0.2295	-0.3467	1.3916	0.6396	160	-0.3857	0.0244	1.2646	0.0391
11	-0.3906	0.3174	1.3086	-0.2832	61	2.251	0.2588	1.5381	0.708	111	-0.2393	-0.3418	1.3965	0.4736	161	-0.3809	0.1172	-0.0781	0.1074
12	-0.4004	0.3955	1.3623	0.1563	62	0.9326	0.1709	1.5332	0.8641	112	-0.2686	-0.3516	1.377	0.6348	162	-0.376	0.2002	1.2891	-0.2002
13	-0.3906	0.4443	1.3525	0.2979	63	0.2441	0.0684	1.5186	0.7422	113	-0.2979	-0.3418	1.3867	0.5127	163	-0.3711	0.2881	-2.8809	-0.7178
14	-0.293	0.5029	1.4014	0.5322	64	-0.0488	-0.0391	1.4941	0.6738	114	-0.2979	-0.3467	1.377	0.6201	164	-0.3613	0.3613	1.3623	-0.8154
15	-0.2295	0.5273	1.3818	0.5518	65	-0.2197	-0.1367	1.4648	0.7178	115	-0.3076	-0.3271	1.3867	0.5518	165	-0.3369	0.4297	-3.5449	-1.1426
16	-0.0977	0.5518	1.4355	0.7227	66	-0.2344	-0.2002	1.4551	0.498	116	-0.3076	-0.3125	1.3818	0.6152	166	-0.3027	0.4883	1.3721	-0.9717
17	0.1807	0.5469	1.4209	0.6152	67	-0.2344	-0.2393	0.8203	0.5176	117	-0.3223	-0.2686	1.3135	0.5908	167	-0.2686	0.5273	-2.6123	-1.0156
18	0.5127	0.5322	1.4697	0.7715	68	-0.249	-0.2637	1.4209	0.2295	118	-0.3076	-0.2539	1.3916	0.6104	168	-0.166	0.5518	1.416	-0.9717
19	0.5762	0.4932	1.4404	0.6006	69	-0.2979	-0.2832	0.1514	0.2686	119	-0.2979	-0.2051	1.4063	0.6104	169	0.0195	0.5615	-5.708	-1.9043
20	0.4785	0.4541	1.499	0.8203	70	-0.2979	-0.3076	1.377	0.1074	120	-0.2734	-0.1563	1.4063	0.625	170	0.3125	0.5566	1.4453	-0.791
21	0.3125	0.3906	1.4697	0.6592	71	-0.3174	-0.3271	-0.1807	0.0684	121	-0.2344	-0.0684	1.4209	0.542	171	0.5908	0.5273	-9.5508	-3.5254
22	0.376	0.3271	1.5186	0.8398	72	-0.3174	-0.3369	1.3135	-0.2344	122	-0.1123	0.0146	1.4307	0.6641	172	0.4443	0.4834	1.4795	-1.6895
23	0.5762	0.2441	1.4893	0.7129	73	-0.3711	-0.3418	-3.7012	-1.04	123	0.0879	0.1123	1.4551	0.4297	173	0.1611	0.4199	-9.9219	-4.1943
24	0.5322	0.1611	1.5283	0.8301	74	-0.3809	-0.3418	1.2988	-1.0107	124	0.4346	0.1953	0.4932	0.459	174	0.1074	0.3467	1.4941	-2.0996
25	0.1416	0.0586	1.4795	0.7275	75	-0.376	-0.3369	-6.0303	-2.1045	125	0.8643	0.2832	1.5039	0.332	175	0.2588	0.2588	-8.6621	-4.0723
26	0.0684	-0.0439	1.5137	0.8008	76	-0.3809	-0.332	1.2793	-1.626	126	1.0107	0.3564	1.1768	0.6348	176	0.3955	0.166	1.5137	-2.0459
27	0.0684	-0.1416	1.4551	0.6836	77	-0.3809	-0.3174	-5.6787	-2.3682	127	1.748	0.4248	1.5332	0.5127	177	0.0977	0.0684	-7.6025	-3.7354
28	-0.2393	-0.1953	1.499	0.7617	78	-0.3809	-0.2979	1.2646	-1.8066	128	2.9297	0.4834	1.2354	0.7324	178	-0.0293	-0.0391	1.4844	-1.8896
29	-0.0732	-0.2393	1.4404	0.5469	79	-0.3857	-0.2734	-4.9561	-2.2607	129	3.9893	0.5322	1.5674	0.4541	179	0.0684	-0.1367	-8.125	-3.8232
30	-0.2344	-0.2637	1.4551	0.7373	80	-0.376	-0.2441	1.2646	-1.7529	130	5.127	0.5566	-1.123	0.1074	180	-0.2051	-0.1953	1.46	-1.9336
31	-0.2295	-0.2881	1.416	0.3271	81	-0.3906	-0.2002	-4.1211	-1.958	131	5.9766	0.5713	1.5869	0.5127	181	-0.1465	-0.2344	-10	-5.1123
32	-0.2393	-0.3027	-0.3467	0.2148	82	-0.3711	-0.1367	1.2695	-1.5625	132	6.333	0.5518	-5.5664	-1.543	182	-0.21	-0.2686	1.4844	-2.6416
33	-0.2344	-0.3223	1.4014	-0.1563	83	-0.3906	-0.0439	-3.75	-1.748	133	6.3135	0.5273	1.5967	-0.4297	183	-0.2197	-0.293	1.4258	-1.3672
34	-0.2393	-0.3271	-1.9238	-0.4102	84	-0.376	0.0488	1.2891	-1.4502	134	5.752	0.4785	-3.4619	-1.6162	184	-0.21	-0.3174	1.4209	-0.5811
35	-0.2539	-0.3369	1.377	-0.5518	85	-0.3955	0.1416	-5.9814	-2.3291	135	4.8633	0.4248	1.5967	-0.4932	185	-0.2197	-0.3369	1.4258	-0.1611
36	-0.2783	-0.332	-1.709	-0.5566	86	-0.3857	0.2295	1.3086	-1.0791	136	3.5791	0.3467	1.5234	-0.0244	186	-0.2539	-0.3467	1.4111	0.166
37	-0.2979	-0.3369	1.3721	-0.5762	87	-0.3955	0.3076	-10	-4.2334	137	2.3242	0.2686	1.5723	0.3906	187	-0.2734	-0.3516	1.3965	0.2881
38	-0.3125	-0.3271	-0.7764	-0.3516	88	-0.3516	0.3809	1.3525	-2.1289	138	0.9814	0.1709	1.499	0.4785	188	-0.2783	-0.3516	1.3867	0.459
39	-0.3174	-0.3174	1.3818	-0.376	89	-0.3418	0.4395	-10	-4.8633	139	0.376	0.0732	1.543	0.6738	189	-0.2881	-0.3516	1.3867	0.4834
40	-0.3125	-0.293	0.1953	-0.0049	90	-0.293	0.4883	1.3965	-2.4951	140	-0.1074	-0.0342	1.4746	0.6299	190	-0.3125	-0.3467	1.3867	0.5664
41	-0.3027	-0.2734	1.3721	-0.1025	91	-0.2393	0.5273	-10	-4.9219	141	-0.2393	-0.127	1.499	0.7422	191	-0.293	-0.3418	1.377	0.5518
42	-0.2881	-0.2393	0.8057	0.2881	92	-0.0928	0.5518	1.4258	-2.5391	142	-0.1758	-0.1904	1.416	0.6348	192	-0.3174	-0.3174	1.3916	0.6152
43	-0.2832	-0.2002	1.3916	0.0781	93	0.127	0.5615	1.416	-1.2549	143	-0.2393	-0.2295	1.4453	0.6982	193	-0.3027	-0.293	1.3721	0.5859
44	-0.2686	-0.1416	0.3125	-0.2539	94	0.4443	0.5469	1.4648	-0.4639	144	-0.2637	-0.2637	1.3965	0.5127	194	-0.3027	-0.2539	1.4014	0.6445
45	-0.2637	-0.0488	1.4111	-0.0781	95	0.5762	0.5225	1.46	0	145	-0.2832	-0.2832	1.4014	0.6738	195	-0.3027	-0.2197	1.3916	0.6152
46	-0.1416	0.0488	-2.1338	-0.4443	96	0.4785	0.4736	1.4893	0.3125	146	-0.3125	-0.3125	1.3574	0.5078	196	-0.293	-0.1611	1.416	0.6738
47	0.0537	0.1416	1.4355	-0.0488	97	0.3174	0.415	1.5186	0.498	147	-0.3271	-0.3271	1.3574	0.6494	197	-0.2588	-0.0879	1.4111	0.6445
48	0.4004	0.2295	-4.8486	-1.5674	98	0.2686	0.3369	1.5039	0.6152	148	-0.3467	-0.3418	1.3086	0.3467	198	-0.1514	0.0146	1.4404	0.7373
49	0.8154	0.3125	1.4844	-0.6055	99	0.415	0.2539	1.4941	0.6787	149	-0.3613	-0.3467	0.5225	0.3906	199	0.0732	0.0977	1.4404	0.625
50	0.9668	0.3857	-3.8818	-1.6553	100	0.5273	0.1563	1.543	0.7227	150	-0.3613	-0.3467	1.3574	0.0488	200	0.4395	0.1904	1.4697	0.752



Tinggi Gel 2 cm  
 Periode 2.0 dt

No	Load cell (Volt)	Seasim (Volt)	Trimmeter 1 (Volt)	Trimmeter 2 (Volt)	No	Load cell (Volt)	Seasim (Volt)	Trimmeter 1 (Volt)	Trimmeter 2 (Volt)	No	Load cell (Volt)	Seasim (Volt)	Trimmeter 1 (Volt)	Trimmeter 2 (Volt)	No	Load cell (Volt)	Seasim (Volt)	Trimmeter 1 (Volt)	Trimmeter 2 (Volt)
1	-0.1953	-0.2686	1.3818	0.6299	51	-0.2734	-0.2783	-1.2549	-0.2246	101	-0.2148	0.3662	-10	-5.6982	151	4.4922	0.3027	-4.6436	-1.0498
2	-0.2295	-0.2832	1.4014	0.5078	52	-0.293	-0.2539	1.3574	-0.3564	102	-0.127	0.4297	1.4404	-2.9102	152	3.4717	0.2344	1.5576	-0.2295
3	-0.2441	-0.3027	1.3379	0.6201	53	-0.3076	-0.2197	-2.2363	-0.6787	103	0.0439	0.4736	1.4258	-1.5186	153	2.1338	0.1611	-9.4678	-3.1836
4	-0.2539	-0.3076	1.3672	0.4346	54	-0.2783	-0.1855	1.3721	-0.6201	104	0.4541	0.5029	1.4697	-0.5713	154	1.0938	0.0879	1.5332	-1.4551
5	-0.2734	-0.3174	0.5322	0.376	55	-0.2783	-0.1221	-1.8311	-0.7129	105	0.9619	0.5176	1.4648	-0.1123	155	0.1904	0.0098	-10	-4.3604
6	-0.3027	-0.3174	1.333	0.0244	56	-0.2686	-0.0293	1.4063	-0.6104	106	0.918	0.5176	1.5137	0.3076	156	-0.1172	-0.0732	1.5088	-2.1826
7	-0.3076	-0.3174	-3.4277	-0.8594	57	-0.2734	0.0684	-2.1924	-0.8252	107	1.1279	0.498	1.5088	0.4492	157	0.0293	-0.1465	-10	-5.3174
8	-0.3027	-0.3125	1.3184	-0.1855	58	-0.21	0.1514	1.4258	-0.4736	108	1.8896	0.4688	1.543	0.6689	158	-0.2246	-0.1904	1.4844	-2.7393
9	-0.3076	-0.3076	-8.7256	-3.0078	59	-0.0537	0.2393	-6.3916	-2.1582	109	2.6221	0.4297	1.5186	0.6836	159	-0.1953	-0.2246	1.4209	-1.4307
10	-0.3223	-0.293	1.3086	-1.4063	60	0.2148	0.3174	1.46	-0.8594	110	2.9932	0.3711	1.5576	0.7764	160	-0.2148	-0.2539	1.4258	-0.6055
11	-0.3076	-0.2783	-10	-4.9707	61	0.7275	0.3857	-10	-3.8037	111	3.0566	0.3125	1.5332	0.6641	161	-0.2295	-0.2686	1.3916	-0.1855
12	-0.3174	-0.249	1.3281	-2.5049	62	1.1133	0.4443	1.5088	-1.7725	112	2.8955	0.249	1.5576	0.8203	162	-0.2246	-0.293	1.3916	0.1514
13	-0.3223	-0.2197	1.2646	-1.3574	63	1.2988	0.4932	-9.541	-4.1553	113	2.251	0.1758	1.5332	0.5859	163	-0.2588	-0.2979	1.3623	0.2686
14	-0.332	-0.1758	1.3232	-0.5176	64	2.2705	0.5273	1.5381	-1.9775	114	1.6504	0.1025	1.5332	0.835	164	-0.2637	-0.3125	1.3477	0.4346
15	-0.3174	-0.1172	1.2939	-0.3027	65	3.5352	0.5371	1.5186	-0.9131	115	0.8203	0.0244	1.5234	0.5518	165	-0.3027	-0.3174	1.3232	0.3223
16	-0.3516	-0.0244	1.333	0.1807	66	4.6533	0.5371	1.5674	-0.1514	116	0.2734	-0.0537	1.5039	0.8203	166	-0.3125	-0.3174	1.2842	0.4834
17	-0.3271	0.0684	1.3428	0.0488	67	5.5957	0.5273	1.5479	0.1904	117	0.1904	-0.127	1.4941	0.5322	167	-0.3125	-0.3174	1.2988	0.1172
18	-0.3174	0.1611	1.2305	0.4736	68	5.918	0.4932	1.5869	0.4932	118	-0.0342	-0.1758	1.4551	0.7813	168	-0.2979	-0.3174	-1.7236	-0.3467
19	-0.2734	0.2441	1.3623	0.2734	69	6.1914	0.4492	1.5625	0.498	119	-0.1416	-0.2148	1.4551	0.3613	169	-0.3125	-0.3076	1.2939	-0.6348
20	-0.21	0.3223	1.2988	0.625	70	5.7422	0.4004	1.5723	0.7422	120	-0.0879	-0.2441	-0.9717	0.0488	170	-0.3076	-0.293	-5.1416	-1.5967
21	-0.1318	0.3955	1.4014	0.2588	71	4.9707	0.3418	1.5576	0.3955	121	-0.1318	-0.2637	1.4355	-0.3906	171	-0.3223	-0.2734	1.2793	-0.6836
22	0	0.459	-1.0449	0.0293	72	3.877	0.2734	-0.4102	0.2832	122	-0.1563	-0.2832	-5.4053	-1.4893	172	-0.3125	-0.249	-9.7461	-3.5889
23	0.3223	0.498	1.4453	-0.3271	73	2.5049	0.2051	1.543	-0.1465	123	-0.1563	-0.293	1.4014	-0.6006	173	-0.3125	-0.2197	1.2939	-1.7969
24	0.8838	0.5322	-3.335	-0.7715	74	1.2451	0.127	-3.1006	-0.6494	124	-0.1709	-0.3076	-7.1777	-2.7197	174	-0.3174	-0.1807	1.2891	-0.8789
25	1.0205	0.542	1.4844	-0.7764	75	0.2979	0.0488	1.5234	-0.6836	125	-0.2051	-0.3125	1.3818	-1.333	175	-0.3174	-0.1172	1.3184	-0.2832
26	1.2402	0.542	-2.8271	-0.8838	76	0.0488	-0.0342	-3.2031	-1.0254	126	-0.2197	-0.3125	-6.8846	-3.0176	176	-0.3076	-0.0293	1.3281	0.0049
27	1.9287	0.5225	1.5186	-0.542	77	-0.0781	-0.1123	-0.4795	-0.3369	127	-0.2393	-0.3174	1.377	-1.5234	177	-0.3125	0.0635	1.3379	0.2979
28	2.8369	0.4883	-3.9551	-1.3232	78	-0.2051	-0.1758	-6.3867	-2.2998	128	-0.2441	-0.3076	-7.1191	-3.2764	178	-0.3027	0.1465	1.3574	0.3711
29	3.2861	0.4443	1.5283	-0.4492	79	-0.1514	-0.2148	1.4355	-1.0742	129	-0.2637	-0.2979	1.3525	-1.6748	179	-0.2979	0.2295	1.3818	0.5273
30	3.5449	0.3906	-7.7393	-2.7148	80	-0.1514	-0.2441	-10	-4.6924	130	-0.2637	-0.2881	-8.4717	-3.7842	180	-0.2588	0.3076	1.3867	0.5273
31	3.4814	0.3271	1.5332	-1.2402	81	-0.1709	-0.2637	1.3965	-2.4268	131	-0.2783	-0.2637	1.3574	-1.9629	181	-0.1709	0.3809	1.416	0.6396
32	3.0322	0.2637	1.5381	-0.3809	82	-0.1953	-0.2832	-10	-5.498	132	-0.2686	-0.249	-9.3311	-4.2236	182	-0.0244	0.4346	1.4502	0.4785
33	2.4951	0.1904	1.5381	0.0488	83	-0.2344	-0.2979	1.3623	-2.9297	133	-0.2686	-0.21	1.3721	-2.207	183	0.2686	0.4834	1.2451	0.6836
34	1.4648	0.1123	1.5332	0.3662	84	-0.2637	-0.3076	1.3281	-1.5234	134	-0.2588	-0.1709	-8.5693	-4.1357	184	0.835	0.5127	1.4697	0.4004
35	0.7764	0.0293	1.5234	0.4932	85	-0.2881	-0.3125	1.3232	-0.7422	135	-0.2686	-0.1074	1.3916	-2.1631	185	1.0205	0.5273	0.8838	0.6445
36	0.3418	-0.0537	1.5137	0.625	86	-0.293	-0.3174	1.3086	-0.293	136	-0.2441	-0.0244	-8.7402	-4.1602	186	0.9668	0.5225	1.5039	0.4199
37	-0.127	-0.1367	1.4941	0.6348	87	-0.3076	-0.3174	1.2939	0	137	-0.2295	0.0732	1.4111	-2.1582	187	1.6211	0.5078	1.1182	0.7129
38	-0.0928	-0.1904	1.4746	0.6982	88	-0.3223	-0.3174	1.2891	0.0293	138	-0.1318	0.1514	-5.2734	-3.2129	188	2.5098	0.4736	1.5381	0.415
39	-0.1904	-0.2246	1.4551	0.6787	89	-0.3223	-0.3076	1.1035	0.2588	139	-0.0195	0.2393	1.4795	-1.582	189	2.9395	0.4297	0.0635	0.4346
40	-0.1465	-0.249	1.4453	0.6787	90	-0.3076	-0.293	1.2842	0.0977	140	0.3857	0.3125	1.4453	-0.6885	190	3.1689	0.376	1.5381	0.0928
41	-0.1465	-0.2734	1.416	0.6348	91	-0.332	-0.2734	0.0732	0.083	141	0.9521	0.3809	1.4941	-0.1221	191	2.9785	0.3174	-2.2656	-0.3418
42	-0.1611	-0.2881	1.416	0.5225	92	-0.3223	-0.2539	1.2842	-0.1025	142	1.1133	0.4346	1.4941	0.2246	192	2.5488	0.2393	1.543	0.1465
43	-0.21	-0.3027	1.3672	0.6201	93	-0.332	-0.2246	-1.4795	-0.4102	143	1.3916	0.4785	1.5234	0.4688	193	1.8701	0.1758	-4.4629	-1.416
44	-0.2295	-0.3125	1.3965	-0.498	94	-0.3271	-0.1807	1.2939	-0.5957	144	2.4316	0.5078	1.5186	0.6152	194	1.1475	0.0928	1.5332	-0.4932
45	-0.2344	-0.3223	1.3574	0.6104	95	-0.3467	-0.1221	-5.0879	-1.582	145	3.5254	0.5176	1.5869	0.7324	195	0.4443	0.0195	-4.8877	-1.9434
46	-0.249	-0.3174	1.3574	0.4736	96	-0.3271	-0.0391	1.3184	-0.6152	146	4.6777	0.5127	1.5479	0.7275	196	0.2393	-0.0684	1.5088	-0.8398
47	-0.249	-0.3223	1.333	0.5957	97	-0.3223	0.0537	-10	-3.9648	147	5.3174	0.498	1.5625	0.8154	197	0.0439	-0.1367	-5.0635	-2.2266
48	-0.2637	-0.3174	1.3574	0.3857	98	-0.2979	0.1367	1.3477	-1.9336	148	5.6396	0.4639	1.5674	0.5664	198	-0.166	-0.1904	1.4746	-1.0254
49	-0.293	-0.3076	0.4346	0.3418	99	-0.2832	0.2197	-10	-5.2588	149	5.7324	0.4199	0.1465	0.4736	199	-0.0732	-0.2246	-9.3115	-3.6523
50	-0.2979	-0.293	1.3525	0.0928	100	-0.2637	0.2979	1.3916	-2.666	150	5.2832	0.3613	1.5674	0.083	200	-0.1514	-0.2588	1.4404	-1.8604



Tinggi Gel  
Periode

4 cm  
1.2 dt

No	Load cell (Volt)	Seasim (Volt)	Trimmer 1 (Volt)	Trimmer 2 (Volt)	No	Load cell (Volt)	Seasim (Volt)	Trimmer 1 (Volt)	Trimmer 2 (Volt)	No	Load cell (Volt)	Seasim (Volt)	Trimmer 1 (Volt)	Trimmer 2 (Volt)	No	Load cell (Volt)	Seasim (Volt)	Trimmer 1 (Volt)	Trimmer 2 (Volt)
1	-0.1611	-0.1758	0.1318	0.083	51	-0.166	-0.2295	0.9424	0.1416	101	-0.1025	-0.2441	0.9668	-1.7285	151	0.0586	-0.2344	-1.0596	-0.3369
2	-0.166	-0.21	-10	-4.1455	52	-0.166	-0.2344	0.9814	0.2002	102	-0.0391	-0.2441	1.0156	-1.0449	152	0.166	-0.2246	1.0205	-0.0488
3	-0.1563	-0.2246	0.957	-2.124	53	-0.127	-0.2441	-3.0322	-1.0303	103	0.0391	-0.2393	1.04	-0.2979	153	0.0977	-0.1904	1.0596	0.0488
4	-0.166	-0.2393	0.9668	-1.6064	54	-0.0537	-0.2393	1.0059	-0.4102	104	0.1611	-0.2246	1.0449	-0.0098	154	-0.0439	-0.1318	1.0693	0.3076
5	-0.1221	-0.2393	1.0059	-0.376	55	0.0488	-0.2393	1.0303	-0.1611	105	0.1221	-0.1953	-10	-3.457	155	-0.0635	0.0195	1.084	0.376
6	-0.0586	-0.2344	0.5664	-0.3027	56	0.1514	-0.2148	1.0498	0.1514	106	0	-0.1367	1.0645	-1.709	156	-0.083	0.1807	-7.9443	-2.4121
7	0.0391	-0.2295	-10	-3.4521	57	0.1172	-0.1953	1.0547	0.2246	107	-0.0684	0.0098	1.0645	-1.4355	157	-0.0781	0.3369	1.0742	-1.1035
8	0.1416	-0.2148	1.0352	-1.8066	58	-0.0244	-0.1221	-6.5283	-2.0361	108	-0.0928	0.1709	1.0938	-0.1563	158	-0.1025	0.4639	1.0596	-0.9277
9	0.1025	-0.1855	1.0645	-1.4014	59	-0.0781	0.0098	1.0596	-0.9619	109	-0.0781	0.3271	-3.6523	-1.4307	159	-0.0879	0.5762	1.0742	0.0684
10	-0.0244	-0.127	1.0693	-0.2539	60	-0.1074	0.1855	1.0889	-0.6982	110	-0.1074	0.459	1.0547	-0.5566	160	-0.1025	0.6348	-2.6514	-0.957
11	-0.0586	0.0146	-3.5449	-1.3818	61	-0.0732	0.332	1.0742	0.0635	111	-0.0977	0.5664	1.0449	-0.4492	161	-0.1172	0.6592	1.0156	-0.3076
12	-0.1123	0.1807	1.0645	-0.6299	62	-0.1074	0.4688	-0.9082	-0.3613	112	-0.0977	0.625	1.0547	0.2002	162	-0.1367	0.6152	0.9912	-0.0732
13	-0.0879	0.3271	1.0791	-0.3662	63	-0.0781	0.5615	1.0352	-0.0195	113	-0.1172	0.6396	0.8887	0.2051	163	-0.1416	0.5469	0.9961	-0.3369
14	-0.1074	0.459	1.0693	0.1514	64	-0.1025	0.6299	1.0449	0.1025	114	-0.127	0.6055	-8.3398	-2.583	164	-0.1318	0.4395	0.9619	0.3613
15	-0.0928	0.5566	0.3271	0.0879	65	-0.1123	0.6348	1.0254	0.3662	115	-0.1367	0.5371	0.9717	-1.2988	165	-0.1611	0.3223	-2.7295	-0.7715
16	-0.0977	0.6299	1.0254	0.2197	66	-0.1367	0.6104	1.0156	0.4199	116	-0.1367	0.4346	0.9619	-0.8496	166	-0.1709	0.1758	0.918	-0.3223
17	-0.1074	0.6543	1.0254	0.3662	67	-0.1465	0.5371	-2.4561	-0.6934	117	-0.1563	0.3223	0.9473	-0.1074	167	-0.166	0.0293	0.9375	-0.2344
18	-0.1367	0.6348	1.0059	-0.0342	68	-0.1367	0.4492	0.957	-0.1855	118	-0.1611	0.1904	-0.293	-0.3125	168	-0.1709	-0.1123	0.9473	0.1611
19	-0.1318	0.5615	1.001	0.5469	69	-0.1465	0.3223	0.9326	-0.1123	119	-0.1611	0.0391	0.7764	-0.1416	169	-0.166	-0.1709	0.5518	0.1025
20	-0.1318	0.4639	0.1318	0.1709	70	-0.1514	0.1953	0.9473	0.249	120	-0.1611	-0.1025	0.9229	-0.0244	170	-0.1611	-0.21	-10	-3.8867
21	-0.1465	0.332	-10	-3.9648	71	-0.1563	0.0391	0.9131	0.2148	121	-0.1709	-0.1709	0.9277	0.1611	171	-0.1611	-0.2197	0.957	-1.9971
22	-0.1611	0.1855	0.9277	-2.1387	72	-0.1611	-0.0977	-9.3115	-2.9248	122	-0.166	-0.21	0.9277	0.2148	172	-0.1563	-0.2393	0.9619	-1.5137
23	-0.1563	0.0293	0.9326	-1.0693	73	-0.1611	-0.1807	0.9131	-1.543	123	-0.1709	-0.2246	-6.5527	-2.1436	173	-0.127	-0.2393	1.001	-0.3711
24	-0.166	-0.1074	0.9277	-0.5371	74	-0.1709	-0.2051	0.9424	-1.25	124	-0.1611	-0.2441	0.9521	-1.04	174	-0.0439	-0.2441	0.9668	-0.1709
25	-0.1611	-0.1807	-6.46	-2.5	75	-0.1611	-0.2295	0.9424	-0.2588	125	-0.127	-0.2441	0.9863	-0.6543	175	0.0586	-0.2393	-9.0283	-3.0518
26	-0.166	-0.2051	0.9326	-1.3232	76	-0.166	-0.2344	-1.4404	-0.7666	126	-0.0537	-0.2441	1.0059	-0.0781	176	0.1904	-0.2295	1.0645	-1.5869
27	-0.1514	-0.2295	0.9521	-0.9521	77	-0.1074	-0.2441	-10	-4.3066	127	0.0293	-0.2344	1.0449	0.0586	177	0.1172	-0.1904	1.0742	-1.2305
28	-0.1465	-0.2393	0.9814	-0.1465	78	-0.0635	-0.2344	1.0107	-2.2168	128	0.1416	-0.2295	-4.6582	-1.5771	178	-0.0244	-0.127	1.0693	-0.2002
29	-0.1025	-0.2393	0.9912	0.0391	79	0.0488	-0.2393	1.0449	-1.5967	129	0.1025	-0.1855	1.0547	-0.7324	179	-0.0732	0.0342	-2.6465	-1.0742
30	-0.0537	-0.2344	-5.8154	-2.002	80	0.1807	-0.2148	1.0596	-0.4248	130	-0.0098	-0.1318	1.0596	-0.5566	180	-0.1025	0.1953	1.0596	-0.459
31	0.0391	-0.2344	1.0156	-0.9473	81	0.1172	-0.1953	-1.5869	-0.9863	131	-0.0684	0.0195	1.0889	0.0977	181	-0.083	0.3516	1.0938	-0.2051
32	0.1563	-0.2148	1.0498	-0.6787	82	-0.0195	-0.127	1.0693	-0.3564	132	-0.0928	0.1855	-0.0342	-0.1025	182	-0.1172	0.4785	1.0742	0.2295
33	0.1074	-0.1953	1.0547	-0.0146	83	-0.0684	-0.0049	1.0645	-0.2197	133	-0.0732	0.3418	1.0693	0.1367	183	-0.0977	0.5762	0.9961	0.3418
34	-0.0146	-0.127	0.3369	-0.1025	84	-0.1074	0.166	1.2061	0.2979	134	-0.1025	0.4639	1.0547	0.2148	184	-0.1074	0.6348	-10	-3.6279
35	-0.0684	0	1.0596	0.1367	85	-0.0732	0.3125	1.0645	0.3076	135	-0.0928	0.5713	1.0645	0.4248	185	-0.1172	0.6494	1.0303	-1.7578
36	-0.0977	0.1758	1.084	0.2295	86	-0.1123	0.4492	-9.126	-2.7441	136	-0.0977	0.625	1.0352	0.4443	186	-0.1318	0.6104	0.9961	-1.2451
37	-0.083	0.3271	1.0791	0.4053	87	-0.0781	0.5566	1.04	-1.3574	137	-0.1172	0.6396	-5.8057	-1.6846	187	-0.1416	0.542	1.0059	-0.2344
38	-0.1025	0.4688	1.084	0.4248	88	-0.0928	0.6299	1.0547	-1.0596	138	-0.1318	0.6006	0.9863	-0.7373	188	-0.127	0.4395	0.6787	-0.1514
39	-0.0684	0.5664	-6.3232	-1.8262	89	-0.1123	0.6494	1.0156	-0.0488	139	-0.1416	0.5273	0.9814	-0.3906	189	-0.1514	0.3174	-10	-3.7354
40	-0.1025	0.6348	1.0352	-0.8008	90	-0.1318	0.6299	-0.5518	-0.3174	140	-0.1367	0.4297	0.957	0.0635	190	-0.1611	0.1807	0.9229	-2.0215
41	-0.1074	0.6494	1.0205	-0.5469	91	-0.1367	0.5518	-10	-4.1211	141	-0.1611	0.3174	0.9473	0.1514	191	-0.1611	0.0293	0.9424	-1.626
42	-0.1318	0.625	1.0254	0.1611	92	-0.1416	0.459	0.9668	-2.0898	142	-0.1563	0.1807	-8.0078	-2.5732	192	-0.166	-0.1074	0.918	-0.4004
43	-0.1416	0.5469	0.9863	0.249	93	-0.1563	0.3271	0.9375	-1.6455	143	-0.1611	0.0342	0.9277	-1.3037	193	-0.166	-0.1709	-5.1904	-2.0215
44	-0.1416	0.4541	-6.6309	-2.0801	94	-0.1514	0.1904	0.9521	-0.3809	144	-0.1465	-0.1074	0.9229	-1.1133	194	-0.1611	-0.21	0.9229	-1.084
45	-0.1563	0.3271	0.9375	-1.0059	95	-0.1465	0.0342	-3.8818	-1.6846	145	-0.166	-0.1709	0.9326	-0.166	195	-0.1514	-0.2295	0.9521	-0.7373
46	-0.1611	0.2002	0.9424	-0.8154	96	-0.1611	-0.1074	0.9229	-0.8008	146	-0.166	-0.21	-2.7148	-1.1572	196	-0.1563	-0.2393	0.9961	-0.1025
47	-0.1514	0.0439	0.9326	-0.0537	97	-0.1709	-0.1807	0.9131	-0.6836	147	-0.1611	-0.2246	0.9424	-0.5371	197	-0.127	-0.249	0.9961	0.083
48	-0.1709	-0.0928	-1.6016	-0.7275	98	-0.166	-0.2051	0.9521	0.0244	148	-0.1563	-0.2441	0.957	-0.2979	198	-0.0537	-0.2441	-4.3604	-1.5527
49	-0.1611	-0.1709	0.9082	-0.3027	99	-0.1611	-0.2246	0.4346	-0.1074	149	-0.1123	-0.2393	0.9961	-0.5371	199	0.0537	-0.2393	1.0254	-0.6787
50	-0.166	-0.21	0.9424	-0.1904	100	-0.1465	-0.2393	-9.7803	-3.2568	150	-0.0391	-0.2441	1.0107	0.2832	200	0.166	-0.2246	1.04	-0.498



Tinggi Gel 4 cm  
Periode 1.3 dt

No	Load cell (Volt)	Seasim (Volt)	Trimmetter 1 (Volt)	Trimmetter 2 (Volt)	No	Load cell (Volt)	Seasim (Volt)	Trimmetter 1 (Volt)	Trimmetter 2 (Volt)	No	Load cell (Volt)	Seasim (Volt)	Trimmetter 1 (Volt)	Trimmetter 2 (Volt)	No	Load cell (Volt)	Seasim (Volt)	Trimmetter 1 (Volt)	Trimmetter 2 (Volt)	No	Load cell (Volt)	Seasim (Volt)	Trimmetter 1 (Volt)	Trimmetter 2 (Volt)
1	-0.127	-0.2637	1.1328	0.4395	51	-0.0781	-0.2734	1.1133	0.2344	101	0.0977	-0.2686	1.084	0.0391	151	-0.1123	-0.2344	1.0205	0.0293					
2	-0.0488	-0.249	-0.3076	-0.0439	52	-0.1123	-0.2686	0.9619	0.2197	102	0.0928	-0.2734	1.0596	0.1221	152	-0.0244	-0.2539	1.04	0.1318					
3	-0.1563	-0.21	1.1035	0.2295	53	-0.0586	-0.2637	-9.8633	-3.042	103	-0.0781	-0.2734	-10	-3.4521	153	0.0928	-0.2686	-5.8154	-1.8994					
4	-0.0684	-0.1611	1.0791	0.249	54	-0.083	-0.2441	1.1035	-1.5625	104	-0.1172	-0.2734	1.0938	-1.7725	154	0.0586	-0.2686	1.0547	-0.9033					
5	-0.1709	-0.0391	1.0938	0.4395	55	-0.127	-0.2148	1.123	-1.0205	105	-0.0635	-0.2637	1.1182	-1.2354	155	-0.1025	-0.2783	1.0889	-0.7373					
6	-0.1563	0.1074	1.0498	0.3906	56	-0.1123	-0.1611	1.1035	-0.2002	106	-0.0781	-0.2441	1.1182	-0.249	156	-0.1367	-0.2637	1.1084	0.0439					
7	-0.1514	0.2637	-7.9102	-2.3193	57	-0.1367	-0.0635	-0.2002	-0.3174	107	-0.1416	-0.2197	0.2783	-0.2246	157	-0.0635	-0.2637	0.2783	-0.0684					
8	-0.166	0.3955	1.0059	-1.1328	58	-0.1807	0.0977	1.0498	-0.0488	108	-0.1074	-0.166	1.084	0.0098	158	-0.1025	-0.2393	1.084	0.1318					
9	-0.1855	0.5225	1.0156	-0.6934	59	-0.1611	0.2539	1.0449	0.0537	109	-0.1465	-0.0732	1.0791	0.1465	159	-0.1563	-0.2148	1.1133	0.2637					
10	-0.2002	0.6152	0.9863	0	60	-0.1807	0.4102	1.0205	0.3223	110	-0.1953	0.1025	1.0596	0.3125	160	-0.1172	-0.1611	1.0986	-0.2393					
11	-0.21	0.6836	0.8984	0.1758	61	-0.1709	0.5322	1.0205	0.4004	111	-0.1563	0.2734	1.0449	0.376	161	-0.1416	-0.0537	1.0791	0.5176					
12	-0.21	0.708	-10	-3.6865	62	-0.2051	0.6348	-4.2432	-1.2695	112	-0.1611	0.4248	-7.4512	-2.2607	162	-0.1953	0.1221	-5.3125	-1.5039					
13	-0.2295	0.6934	0.9424	-1.875	63	-0.1855	0.6836	0.9668	-0.4736	113	-0.1807	0.542	0.9961	-1.04	163	-0.1514	0.2832	1.0205	-0.6396					
14	-0.2246	0.6348	0.9082	-0.9229	64	-0.2197	0.7031	0.9424	-0.3809	114	-0.1904	0.625	0.9863	-0.6689	164	-0.1758	0.4297	1.0156	-0.4639					
15	-0.2344	0.5371	0.9277	-0.3809	65	-0.2246	0.6787	0.9521	0.2344	115	-0.2002	0.6641	1.0693	0.0537	165	-0.1807	0.5273	1.0205	0.1855					
16	-0.2295	0.4102	-7.9639	-2.9102	66	-0.2295	0.625	-0.4004	-0.1807	116	-0.2246	0.6787	0.9229	0.1367	166	-0.2148	0.6006	0.9814	0.2588					
17	-0.2295	0.2588	0.9277	-1.4502	67	-0.2295	0.5225	0.9082	0.0977	117	-0.2246	0.6494	-10	-3.5742	167	-0.2051	0.6445	-7.7588	-2.4023					
18	-0.2246	0.0879	0.9277	-1.2598	68	-0.2295	0.4004	0.918	0.0293	118	-0.2246	0.5957	0.9277	-1.8896	168	-0.2246	0.6641	0.9326	-1.167					
19	-0.2197	-0.0732	0.9814	-0.1758	69	-0.2197	0.249	0.9375	0.3467	119	-0.2295	0.5078	0.9277	-0.874	169	-0.2246	0.6494	0.9277	-1.0254					
20	-0.1904	-0.1758	-0.6006	-0.542	70	-0.2295	0.0928	0.9277	0.2686	120	-0.2441	0.4004	0.9277	-0.4297	170	-0.2344	0.6055	0.9277	-0.0537					
21	-0.1172	-0.2197	-10	-4.0479	71	-0.2344	-0.0781	-8.9404	-2.7588	121	-0.2295	0.2539	-7.832	-2.8467	171	-0.2295	0.5273	-4.4922	-1.5869					
22	0	-0.2539	1.0156	-2.1777	72	-0.21	-0.1758	0.9668	-1.4355	122	-0.2344	0.0879	0.9424	-1.4941	172	-0.2344	0.4102	0.918	-0.752					
23	0.1123	-0.2637	1.0645	-1.04	73	-0.1318	-0.2295	1.0107	-0.9131	123	-0.2197	-0.0879	0.9668	-1.0693	173	-0.2246	0.2539	0.9277	-0.6543					
24	0.0928	-0.2734	1.0645	-0.5322	74	-0.0537	-0.2539	1.0303	-0.1758	124	-0.1416	-0.1807	1.0059	-0.2441	174	-0.2344	0.0781	0.957	0.0293					
25	-0.1709	-0.2734	-5.7422	-2.2363	75	0.0879	-0.2686	0.6201	-0.0684	125	-0.0928	-0.2344	1.001	-0.0195	175	-0.21	-0.0977	-0.1904	-0.2441					
26	-0.2051	-0.2686	1.084	-1.1279	76	0.0781	-0.2734	1.04	0.0732	126	-0.0195	-0.2539	-9.7363	-3.2471	176	-0.166	-0.1904	-10	-3.6865					
27	-0.0049	-0.2588	1.1279	-0.625	77	-0.0342	-0.2783	1.0791	0.1855	127	0.1221	-0.2686	1.0449	-1.6357	177	-0.0928	-0.2393	1.001	-1.9189					
28	-0.083	-0.249	1.1523	-0.0488	78	-0.1221	-0.2686	1.0938	0.3223	128	0.0684	-0.2686	1.0889	-0.7959	178	-0.0195	-0.2539	1.0352	-1.416					
29	-0.0879	-0.2148	1.1377	0.1807	79	-0.1074	-0.2637	1.1133	0.4004	129	-0.1221	-0.2734	1.0938	-0.3125	179	0.1172	-0.2686	1.0596	-0.3418					
30	-0.0391	-0.1611	-5.4639	-1.8018	80	-0.0781	-0.2441	-3.7061	-1.1182	130	-0.1514	-0.2686	-3.3936	-1.4502	180	0.0684	-0.2686	-3.0078	-1.3281					
31	-0.166	-0.0586	1.0889	-0.7764	81	-0.1709	-0.2148	1.0938	-0.3955	131	-0.0439	-0.2637	1.0938	-0.6299	181	-0.1172	-0.2734	1.0693	-0.5957					
32	-0.1221	0.0977	1.0596	-0.7129	82	-0.0879	-0.1611	1.084	-0.3027	132	-0.1074	-0.2441	1.1133	-0.3174	182	-0.1367	-0.2637	1.1035	-0.3369					
33	-0.1904	0.2539	1.0693	0.127	83	-0.1709	-0.0635	1.084	0.2588	133	-0.1318	-0.2197	1.1035	0.1172	183	-0.0537	-0.2637	1.2012	0.1611					
34	-0.1904	0.4004	-1.5967	-0.625	84	-0.1758	0.1025	0.0635	-0.0342	134	-0.1074	-0.1611	1.1035	0.21	184	-0.1074	-0.2441	1.1182	0.2588					
35	-0.2148	0.5225	1.0059	-0.1221	85	-0.1611	0.2637	1.0205	0.2051	135	-0.1416	-0.0586	-7.4658	-2.3438	185	-0.1367	-0.2197	-5.498	-1.7334					
36	-0.1953	0.625	0.9814	0.0391	86	-0.1709	0.4102	1.0059	0.249	136	-0.1904	0.1172	1.0596	-1.1426	186	-0.1221	-0.1611	1.0889	-0.7813					
37	-0.2051	0.6836	0.9863	-0.2783	87	-0.1807	0.5371	1.0059	-0.0879	137	-0.1758	0.2783	1.0352	-0.9717	187	-0.1367	-0.0488	1.0693	-0.6543					
38	-0.2197	0.7031	0.9521	0.4102	88	-0.2051	0.6201	0.9814	0.4932	138	-0.1904	0.4248	1.0303	-0.0098	188	-0.1855	0.1318	1.0645	0.0977					
39	-0.2148	0.6885	-4.3018	-1.1914	89	-0.2051	0.6738	-1.3574	-0.2393	139	-0.1807	0.5273	-0.835	-0.4102	189	-0.1709	0.2881	-1.8066	-0.6738					
40	-0.2344	0.6299	0.9082	-0.5371	90	-0.2246	0.6885	0.9277	0.0195	140	-0.21	0.6104	-9.9023	-3.5889	190	-0.1807	0.4248	1.0107	-0.1904					
41	-0.2344	0.5322	0.9375	-0.4639	91	-0.2197	0.6689	0.9326	0.0391	141	-0.2002	0.6445	0.957	-1.8408	191	-0.1807	0.5225	0.9961	0.0098					
42	-0.2344	0.4102	0.9277	0.1172	92	-0.2393	0.6104	1.0205	0.376	142	-0.2246	0.6641	0.9521	-1.543	192	-0.21	0.5957	0.9912	-0.3418					
43	-0.2295	0.2637	-2.0361	-0.6934	93	-0.2295	0.5225	0.3906	0.2246	143	-0.2295	0.6445	0.9326	-0.2441	193	-0.21	0.6348	0.9668	0.4297					
44	-0.2393	0.0977	0.9277	-0.3027	94	-0.2344	0.4053	-10	-4.0137	144	-0.2295	0.6055	-6.9531	-2.4854	194	-0.2295	0.6543	-3.7646	-1.0547					
45	-0.2197	-0.0732	0.9717	-0.0879	95	-0.2344	0.2637	0.9277	-2.1191	145	-0.2393	0.5225	0.9082	-1.2354	195	-0.2246	0.6396	0.918	-0.4297					
46	-0.1318	-0.1758	0.9912	-0.4736	96	-0.2441	0.0928	0.9424	-1.0498	146	-0.2344	0.4102	0.918	-1.0938	196	-0.2246	0.6055	0.9277	-0.4053					
47	-0.0977	-0.2246	1.0352	0.4053	97	-0.2246	-0.0781	0.9717	-0.4932	147	-0.2344	0.2588	0.8008	-0.1514	197	-0.2295	0.5225	0.9277	0.166					
48	-0.0146	-0.2539	-3.3398	-1.0205	98	-0.1855	-0.1758	-3.8477	-1.7236	148	-0.2295	0.083	-3.6182	-1.4209	198	-0.2393	0.4053	-1.6895	-0.5811					
49	0.1172	-0.2686	1.0449	-0.3662	99	-0.0977	-0.2295	0.9961	-0.8105	149	-0.2246	-0.0928	0.9473	-0.6689	199	-0.2295	0.249	0.9131	-0.2002					
50	0.1074	-0.2734	1.0693	-0.3809	100	-0.0391	-0.2539	1.0254	-0.5029	150	-0.1758	-0.1855	0.9912	-0.3809	200	-0.2393	0.0684	0.9473	-0.1318					



Tinggi Gel  
Periode

4 cm  
1.4 dt

No	Load cell (Volt)	Seasim (Volt)	Trimmetter 1 (Volt)	Trimmetter 2 (Volt)	No	Load cell (Volt)	Seasim (Volt)	Trimmetter 1 (Volt)	Trimmetter 2 (Volt)	No	Load cell (Volt)	Seasim (Volt)	Trimmetter 1 (Volt)	Trimmetter 2 (Volt)	No	Load cell (Volt)	Seasim (Volt)	Trimmetter 1 (Volt)	Trimmetter 2 (Volt)
1	-0.2051	0.542	0.9229	0.3516	51	-0.1611	-0.2344	1.0693	0.1758	101	0.0488	-0.2979	1.1426	0.2539	151	-0.1855	0.2246	0.9961	0.0488
2	-0.21	0.6494	0.9131	0.0586	52	-0.1563	-0.1807	1.0547	0.376	102	0.2832	-0.3076	1.1475	0.3223	152	-0.1123	0.0293	-0.2148	-0.2441
3	-0.2295	0.7373	0.9131	0.4785	53	-0.1758	-0.0684	1.0254	0.3516	103	0.2441	-0.3027	-2.5537	-0.7617	153	0.0195	-0.1416	1.0205	0.0391
4	-0.2344	0.791	-1.3721	-0.2393	54	-0.166	0.0977	-7.2021	-2.1875	104	-0.0342	-0.3027	1.1182	-0.2441	154	0.2441	-0.2295	1.0498	0.0439
5	-0.2197	0.8105	0.8838	0.0342	55	-0.2002	0.2637	0.9668	-1.0596	105	-0.0732	-0.2832	1.123	-0.0488	155	0.1611	-0.2686	1.1719	0.376
6	-0.2295	0.7813	0.8984	0.1123	56	-0.1953	0.4004	0.9473	-0.8691	106	-0.0732	-0.2637	1.0986	0.249	156	-0.0488	-0.3027	1.1133	0.3662
7	-0.2344	0.7227	0.9473	0.3516	57	-0.21	0.5273	0.9326	-0.0342	107	-0.1367	-0.2295	1.0742	0.3027	157	-0.0293	-0.3027	-5.8789	-1.7432
8	-0.2197	0.625	0.9131	0.3711	58	-0.21	0.6299	-3.7061	-1.3232	108	-0.127	-0.1807	-10	-3.4766	158	0.127	-0.3125	1.123	-0.8008
9	-0.2148	0.5029	-10	-3.2764	59	-0.2295	0.7178	0.8984	-0.5859	109	-0.1855	-0.0781	1.0254	-1.7822	159	0.1904	-0.3076	1.1475	-0.4492
10	-0.1953	0.3516	0.9814	-1.6113	60	-0.2197	0.7764	0.8984	-0.4102	110	-0.1953	0.083	1.001	-1.416	160	-0.0342	-0.3076	1.1426	0.1025
11	-0.2002	0.1953	1.1133	-1.1768	61	-0.2344	0.8057	0.9668	0.1709	111	-0.2197	0.2393	0.9863	-0.2539	161	-0.1172	-0.2881	1.123	0.249
12	-0.1025	0.0098	1.0303	-0.1807	62	-0.2246	0.7861	0.7861	0.21	112	-0.21	0.3809	-3.5449	-1.4355	162	-0.0635	-0.2686	-8.916	-2.8174
13	0.0977	-0.1465	-2.0361	-0.9424	63	-0.2197	0.7373	-10	-3.3301	113	-0.2148	0.5127	0.9229	-0.6543	163	-0.1807	-0.2344	1.0693	-1.3818
14	0.1611	-0.2246	1.0645	-0.3418	64	-0.21	0.6445	0.9082	-1.7188	114	-0.2148	0.6201	0.9082	-0.6006	164	-0.166	-0.1807	1.0449	-0.6543
15	0.1416	-0.2588	1.1182	-0.1904	65	-0.2246	0.5225	0.9375	-0.8105	115	-0.2197	0.7178	0.9131	0.1074	165	-0.1758	-0.0732	1.04	-0.2344
16	0.0879	-0.2881	1.2354	0.293	66	-0.1953	0.3711	0.957	-0.3516	116	-0.2197	0.7764	-1.0498	-0.4199	166	-0.1807	0.0781	-4.2139	-1.6553
17	0.3027	-0.293	1.1572	0.3369	67	-0.1709	0.2051	-4.292	-1.7236	117	-0.2246	0.8057	-10	-4.2383	167	-0.2002	0.2441	0.9717	-0.7617
18	0.5225	-0.3027	-5.8545	-1.7529	68	-0.1221	0.0098	1.001	-0.8203	118	-0.2393	0.7861	0.8838	-2.2656	168	-0.2002	0.3857	0.9473	-0.5908
19	0.4004	-0.2979	1.1426	-0.791	69	0.0439	-0.1514	1.0303	-0.5811	119	-0.2393	0.7324	0.9082	-1.748	169	-0.2148	0.5176	0.9229	0.1025
20	0.6084	-0.2979	1.1426	-0.4932	70	0.2441	-0.2246	1.0986	0.0195	120	-0.2197	0.6348	0.9082	-0.3955	170	-0.2148	0.6201	-1.3574	-0.5518
21	-0.0781	-0.293	1.1426	0.1172	71	0.1465	-0.2637	0.293	-0.0879	121	-0.21	0.5127	-7.5488	-2.7344	171	-0.2295	0.7129	0.8984	-0.127
22	-0.0098	-0.2637	1.0986	0.2441	72	-0.0244	-0.293	1.1035	0.1318	122	-0.1807	0.3662	0.9375	-1.4063	172	-0.2246	0.7666	0.8936	-0.083
23	-0.2002	-0.2295	0.6885	0.0342	73	0.1025	-0.2979	1.1328	0.2637	123	-0.1611	0.2051	0.9863	-1.0059	173	-0.2246	0.791	0.9033	0.2881
24	-0.1563	-0.1758	1.0449	0.1367	74	0.293	-0.3076	1.1426	-0.0879	124	-0.083	0.0098	1.0156	-0.1904	174	-0.2295	0.7715	0.8887	0.2734
25	-0.1904	-0.0635	1.04	0.3223	75	0.3076	-0.3027	1.167	0.5127	125	0.0244	-0.1465	-0.0928	-0.3271	175	-0.2344	0.7227	-8.4277	-2.5635
26	-0.1953	0.0977	1.0156	0.3516	76	0.0049	-0.3027	-0.2051	0.0732	126	0.2393	-0.2295	1.0547	-0.0488	176	-0.2148	0.6299	0.9033	-1.2891
27	-0.1953	0.2588	-4.8633	-1.4844	77	-0.1074	-0.2881	1.1133	0.2441	127	0.1465	-0.2686	1.0938	0.0439	177	-0.21	0.5273	0.9424	-1.1572
28	-0.2051	0.3955	0.9473	-0.6494	78	0.0049	-0.2637	1.0986	0.2832	128	-0.0293	-0.2979	1.1133	0.3076	178	-0.2002	0.376	0.957	-0.0879
29	-0.21	0.5322	0.9375	-0.6396	79	-0.1611	-0.2295	1.084	0.4053	129	-0.0098	-0.3076	1.1475	0.376	179	-0.1855	0.2197	-2.7344	-1.0547
30	-0.21	0.6396	0.918	0.1318	80	-0.1465	-0.1758	1.0547	0.3857	130	0.1758	-0.3125	-3.8428	-1.1572	180	-0.1221	0.0244	0.9912	-0.4688
31	-0.2246	0.7373	-2.998	-1.0059	81	-0.2002	-0.0684	-9.4775	-2.8711	131	0.21	-0.3125	1.1377	-0.4297	181	0.0244	-0.1416	1.04	-0.2637
32	-0.2197	0.7861	0.8838	-0.3857	82	-0.1953	0.0879	0.9912	-1.4307	132	-0.0098	-0.3027	1.1279	-0.2148	182	0.2295	-0.2344	1.0693	0.166
33	-0.2295	0.8105	0.8984	-0.2441	83	-0.2197	0.2441	0.874	-1.084	133	-0.1318	-0.2881	1.1426	0.2197	183	0.1709	-0.2686	1.0693	0.2686
34	-0.2246	0.7861	0.8984	0.21	84	-0.2002	0.3809	0.957	-0.1758	134	-0.0537	-0.2686	1.0938	0.2637	184	-0.0146	-0.3027	-9.5752	-2.998
35	-0.2295	0.7324	0.8936	0.2393	85	-0.21	0.5127	-2.7539	-1.123	135	-0.1807	-0.2295	-10	-3.2861	185	0.0928	-0.3027	1.1377	-1.4453
36	-0.2197	0.6348	-10	-3.1787	86	-0.2197	0.6201	0.9082	-0.4834	136	-0.1758	-0.1807	1.04	-1.7139	186	0.2637	-0.3174	1.1475	-1.0352
37	-0.2295	0.5176	0.9277	-1.6553	87	-0.2344	0.7178	0.9229	-0.4004	137	-0.1758	-0.0732	1.0352	-1.2939	187	0.293	-0.3076	1.1572	-0.1172
38	-0.21	0.3613	0.9521	-1.4063	88	-0.2197	0.7813	0.8984	0.21	138	-0.1709	0.083	1.0059	-0.2393	188	0.0146	-0.3076	0.8691	-0.0146
39	-0.1758	0.2002	0.9912	-0.1855	89	-0.2344	0.8154	-0.0879	-0.0439	139	-0.2002	0.2441	-3.1982	-1.2988	189	-0.1172	-0.2881	-9.8438	-3.2275
40	-0.1074	0.0098	-2.3242	-1.0059	90	-0.2295	0.7959	-10	-4.1162	140	-0.2002	0.3857	0.9326	-0.6104	190	-0.0146	-0.2734	1.0938	-1.6553
41	0.0293	-0.1465	1.0205	-0.4297	91	-0.2246	0.7422	0.9082	-2.1875	141	-0.2002	0.5176	0.9326	-0.5225	191	-0.1807	-0.2295	1.0889	-0.7617
42	0.2539	-0.2246	1.0596	-0.3271	92	-0.21	0.6396	0.918	-1.0547	142	-0.2148	0.625	0.9131	0.0928	192	-0.1611	-0.1807	1.0547	-0.3564
43	0.1514	-0.2637	1.1035	0.1709	93	-0.2002	0.5176	0.9375	-0.5029	143	-0.2295	0.7178	-1.5234	-0.5518	193	-0.1953	-0.0732	-7.5439	-2.71
44	-0.0928	-0.2881	1.1035	0.2686	94	-0.1807	0.3662	-7.9834	-2.9541	144	-0.2246	0.7764	0.9082	-0.1611	194	-0.2051	0.0879	0.9912	-1.4014
45	-0.0195	-0.2979	-9.0186	-2.8027	95	-0.1514	0.2002	0.9814	-1.5088	145	-0.2344	0.8008	0.8984	0.0049	195	-0.2148	0.2588	0.9912	-0.9375
46	0.1758	-0.3027	1.1279	-1.3525	96	-0.083	0.0098	1.0156	-1.0352	146	-0.2344	0.7813	0.8936	-0.4199	196	-0.21	0.4004	0.9619	-0.1855
47	0.1318	-0.3027	1.1426	-0.9521	97	0.0586	-0.1514	1.0498	-0.2246	147	-0.2246	0.7275	0.9082	0.4492	197	-0.21	0.5273	-1.2256	-0.6299
48	-0.0146	-0.2979	1.1377	-0.0977	98	0.2246	-0.2246	-1.0596	-0.6641	148	-0.2197	0.6348	-6.5576	-1.9336	198	-0.2197	0.625	0.9082	-0.2393
49	-0.083	-0.2881	0.9082	0.0244	99	0.083	-0.2686	1.0889	-0.21	149	-0.21	0.5225	0.9229	-0.8984	199	-0.2246	0.7129	0.9131	-0.1611
50	-0.1221	-0.2686	1.0742	0.1855	100	-0.0537	-0.2979	1.1133	-0.0098	150	-0.1904	0.3857	0.9473	-0.8398	200	-0.2246	0.7617	0.9229	0.2441



Tinggi Gel 4 cm  
Periode 1.5 dt

No	Load cell (Volt)	Seasim (Volt)	Trimmetter 1 (Volt)	Trimmetter 2 (Volt)	No	Load cell (Volt)	Seasim (Volt)	Trimmetter 1 (Volt)	Trimmetter 2 (Volt)	No	Load cell (Volt)	Seasim (Volt)	Trimmetter 1 (Volt)	Trimmetter 2 (Volt)	No	Load cell (Volt)	Seasim (Volt)	Trimmetter 1 (Volt)	Trimmetter 2 (Volt)
1	-0.2197	0.1514	0.9277	0.3711	51	0.1709	-0.3418	1.1475	-0.0342	101	-0.2197	0.6934	0.918	0.1025	151	-0.2197	0.1367	-1.2061	-0.4492
2	-0.2246	0.3174	-6.9092	-2.1143	52	-0.0928	-0.3516	1.2354	0.293	102	-0.2246	0.5859	0.9766	0.1514	152	-0.2197	0.3076	0.8984	-0.0879
3	-0.2344	0.4785	0.8936	-0.9717	53	-0.0928	-0.3564	1.123	0.376	103	-0.1563	0.4492	1.0107	0.3711	153	-0.2344	0.4443	0.874	-0.0684
4	-0.2344	0.5957	0.874	-0.8057	54	-0.1074	-0.3564	-10	-3.1738	104	0.0146	0.3078	1.0352	0.376	154	-0.2441	0.5762	0.8838	0.2734
5	-0.2393	0.7031	0.8887	0.0488	55	-0.1514	-0.3516	1.0693	-1.326	105	0.332	0.1465	-10	-3.2471	155	-0.2441	0.6689	0.8594	0.2588
6	-0.2344	0.7764	-0.4736	-0.2979	56	-0.1123	-0.3369	1.0498	-0.7617	106	0.3223	-0.0195	1.1035	-1.6211	156	-0.2588	0.7617	-5.9473	-1.8018
7	-0.249	0.8447	-10	-4.2041	57	-0.1709	-0.3076	1.0205	-0.3027	107	0.083	-0.1514	1.1279	-0.7227	157	-0.249	0.8203	0.8594	-0.874
8	-0.2344	0.8545	0.8887	-2.2803	58	-0.1953	-0.2539	-9.1553	-3.2617	108	0.1221	-0.2295	1.1523	-0.2588	158	-0.2393	0.8643	0.8936	-0.5957
9	-0.2246	0.8398	0.9229	-1.0303	59	-0.2002	-0.1758	0.9619	-1.6748	109	0.3955	-0.2881	-3.623	-1.4404	159	-0.2197	0.8545	0.9033	0.0732
10	-0.2393	0.7764	0.8936	-0.5322	60	-0.2051	-0.0244	0.9375	-0.8887	110	0.5176	-0.3271	1.1426	-0.6348	160	-0.2393	0.8154	-1.8213	-0.6348
11	-0.249	0.6934	-10	-3.877	61	-0.2197	0.1611	0.918	-0.3955	111	0.21	-0.3467	1.1475	-0.4297	161	-0.2051	0.7178	0.9277	-0.2148
12	-0.2295	0.5762	0.9814	-2.0313	62	-0.2344	0.332	-9.7314	-3.4766	112	-0.0293	-0.3516	1.1475	0.1172	162	-0.2246	0.5957	0.9912	-0.083
13	-0.1318	0.4395	1.0352	-1.5186	63	-0.2393	0.4736	0.8887	-1.7725	113	0.0342	-0.3613	1.001	0.1904	163	-0.1563	0.4443	1.0498	0.2979
14	0.1367	0.2783	1.0547	-0.3174	64	-0.2441	0.5957	0.8789	-1.4111	114	-0.1465	-0.3564	1.0889	0.2686	164	0.0537	0.3027	0.835	0.3076
15	0.3271	0.1221	-7.2998	-2.5684	65	-0.2393	0.6787	0.8938	-0.2734	115	-0.127	-0.3564	1.0645	0.1758	165	0.3516	0.1221	1.0498	0.332
16	0.2686	-0.0537	1.1035	-1.2939	66	-0.2393	0.7568	-1.7578	-0.9033	116	-0.1709	-0.3369	1.0596	0.415	166	0.3369	-0.0391	1.1426	0.3369
17	0.1855	-0.1709	1.1523	-0.8887	67	-0.2393	0.6057	0.874	-0.3223	117	-0.1611	-0.3125	0.9955	0.1709	167	0.1855	-0.1758	1.1279	0.4785
18	0.5469	-0.2441	1.1572	-0.0781	68	-0.249	0.8301	0.8338	-0.2197	118	-0.1953	-0.2588	-10	-3.8916	168	0.0635	-0.2393	1.1572	0.5127
19	0.8301	-0.2881	-1.6748	-0.7031	69	-0.2393	0.8203	0.9277	0.2797	119	-0.2002	-0.1758	0.9619	-2.1045	169	0.2783	-0.2979	-6.5088	-1.9043
20	0.6445	-0.3271	1.1377	-0.2539	70	-0.249	0.7764	0.1221	-0.0146	120	-0.2002	-0.0391	0.9424	-1.0205	170	0.4004	-0.3271	1.1572	-0.8154
21	0.3857	-0.3369	1.167	-0.1318	71	-0.2393	0.6934	0.9473	0.21	121	-0.2051	0.1416	0.6104	-0.6104	171	-0.1611	-0.3516	1.1475	-0.6885
22	0.2832	-0.3516	1.1475	0.2344	72	-0.1807	0.5811	0.9912	0.2344	122	-0.2197	0.3125	-10	-4.4922	172	-0.0879	-0.3564	1.1572	0.1172
23	-0.1416	-0.3516	1.123	0.3418	73	-0.083	0.4443	1.0352	0.4199	123	-0.2295	0.4492	0.8838	-2.4365	173	-0.0586	-0.3711	-0.5176	-0.3223
24	-0.1709	-0.3564	1.0742	0.3223	74	-0.1465	0.2881	1.0596	0.3906	124	-0.2539	0.5713	0.8838	-1.875	174	-0.1367	0.3613	1.084	0.0293
25	-0.0684	-0.3516	1.084	0.2881	75	0.3271	0.127	-9.9707	-2.959	125	-0.2393	0.6689	0.874	-0.4736	175	-0.166	-0.3613	1.0547	-0.166
26	-0.166	-0.3369	1.0596	0.415	76	0.2441	-0.0391	1.1133	-1.4697	126	-0.2441	0.7568	-3.916	-1.6553	176	-0.1123	-0.3418	1.0596	0.332
27	-0.1953	-0.3027	0.8887	0.3711	77	-0.1807	-0.1611	1.1426	-1.1084	127	-0.2344	0.8154	0.8691	-0.8008	177	-0.1709	-0.3174	-1.1865	-0.4102
28	-0.2051	-0.2588	-10	-3.5107	78	0.5615	-0.2344	1.1621	-0.0928	128	-0.249	0.8594	0.8984	-0.5566	178	-0.2002	-0.2539	0.9863	-0.0537
29	-0.2197	-0.1709	0.9717	-1.8311	79	0.8447	-0.2881	-3.3105	-1.2256	129	-0.2246	0.8496	0.9082	0.0732	179	-0.21	-0.1758	0.9521	-0.1318
30	-0.2148	-0.0342	0.9229	-0.9229	80	0.6689	-0.3223	1.1475	-0.5322	130	-0.2246	0.8008	-1.7041	-0.6299	180	-0.21	-0.0244	0.9473	0.293
31	-0.2148	0.1611	0.8691	-0.4199	81	0.4102	-0.3418	1.1572	-0.4053	131	-0.2148	0.708	0.9473	-0.1953	181	-0.2246	0.1563	-1.0205	-0.3613
32	-0.2246	0.3271	-10	-3.7354	82	0.2832	-0.3516	1.1572	0.1709	132	-0.1953	0.5908	1.001	-0.0439	182	-0.2344	0.3271	0.8887	-0.0195
33	-0.2441	0.4785	0.8789	-1.9141	83	-0.1221	-0.3564	0.3467	0.0488	133	-0.0928	0.4443	1.0986	0.3027	183	-0.2344	0.4639	0.8691	-0.0146
34	-0.249	0.5957	0.8545	-1.5088	84	-0.166	-0.3613	1.0889	0.1709	134	0.1221	0.2979	0.791	0.2832	184	-0.2393	0.5957	0.8838	-0.3564
35	-0.249	0.6836	0.874	-0.3271	85	-0.0244	-0.3564	1.0742	0.1074	135	0.3223	0.1416	1.0645	0.3467	185	-0.2393	0.6934	0.8594	0.4053
36	-0.2441	0.7617	-2.2998	-1.1035	86	-0.1465	-0.3369	1.0645	0.3857	136	0.2344	-0.0244	1.1182	0.376	186	-0.2393	0.7861	-4.9805	-1.3916
37	-0.249	0.8105	0.874	-0.4297	87	-0.1709	-0.3125	-0.1563	0.0098	137	0.0928	-0.1563	1.1328	0.4688	187	-0.249	0.8545	0.8545	-0.6494
38	-0.249	0.835	0.8789	-0.249	88	-0.1953	-0.2588	0.9963	0.1221	138	0.5029	-0.2295	1.1719	0.4932	188	-0.2344	0.8936	0.8936	-0.4102
39	-0.2539	0.8252	0.9033	0.1807	89	-0.21	-0.1807	0.957	0.1123	139	0.7666	-0.293	-6.3135	-1.8359	189	-0.2295	0.8838	0.9033	0.1416
40	-0.2686	0.7715	0.8887	0.1904	90	-0.2246	-0.0342	0.9424	0.3027	140	0.6396	-0.3271	1.1572	-0.791	190	-0.2441	0.8252	-1.4844	-0.4736
41	-0.249	0.6885	-10	-3.7646	91	-0.21	0.1465	0.0244	0.0391	141	0.4248	-0.3467	1.1475	-0.7275	191	-0.21	0.7227	0.9326	-0.1318
42	-0.2246	0.5713	0.9863	-1.9775	92	-0.2295	0.3174	-10	-4.1016	142	0.2588	-0.3564	1.1621	0.1416	192	-0.2197	0.5908	0.9961	0.0195
43	-0.1758	0.4346	1.0449	-1.5137	93	-0.249	0.4541	0.8391	-2.1631	143	-0.1025	-0.3662	-1.46	-0.5762	193	-0.1074	0.4395	1.0303	0.3027
44	-0.0391	0.2783	1.0449	-0.2686	94	-0.2539	0.5811	0.874	-1.7188	144	-0.1563	-0.3564	1.1035	-0.127	194	0.1318	0.2832	0.9277	0.3564
45	0.2637	0.1172	-7.7051	-2.666	95	-0.2393	0.6689	0.8545	-0.3662	145	-0.0244	-0.3613	1.0791	-0.2148	195	0.3516	0.1074	1.0596	0.3564
46	0.2881	-0.0537	1.0889	-1.3574	96	-0.2441	0.752	-3.6816	-1.5332	146	-0.1416	-0.3369	1.0693	0.2734	196	0.2539	-0.0635	1.1182	0.4004
47	0.1318	-0.1709	1.1279	-1.0303	97	-0.2441	0.8057	0.8594	-0.7031	147	-0.166	-0.3125	-1.9333	-0.6592	197	0.1123	-0.1807	1.123	0.459
48	0.0391	-0.2441	1.1426	-0.1025	98	-0.2393	0.835	0.8789	-0.4541	148	-0.2051	-0.2539	0.9912	-0.2051	198	0.3662	-0.2539	1.167	0.5176
49	0.1953	-0.293	-1.4697	-0.6543	99	-0.2295	0.8252	0.9033	0.0879	149	-0.21	-0.1807	0.957	-0.21	199	0.6055	-0.3027	-5.9766	-1.7432
50	0.3223	-0.3223	1.1279	-0.2295	100	-0.2246	0.7861	-0.0488	-0.127	150	-0.2197	-0.0439	0.957	0.2295	200	0.5273	-0.332	1.1572	-0.7178



Tinggi Gel  
Periode

4 cm  
1.6 dt

No	Load cell (Volt)	Seasim (Volt)	Trimmer 1 (Volt)	Trimmer 2 (Volt)	No	Load cell (Volt)	Seasim (Volt)	Trimmer 1 (Volt)	Trimmer 2 (Volt)	No	Load cell (Volt)	Seasim (Volt)	Trimmer 1 (Volt)	Trimmer 2 (Volt)	No	Load cell (Volt)	Seasim (Volt)	Trimmer 1 (Volt)	Trimmer 2 (Volt)
1	-0.293	-0.2979	-3.1982	-0.8887	51	0.332	0.498	-2.5781	-0.7764	101	-0.3174	-0.0684	0.874	-0.8838	151	0.8105	-0.1807	1.1621	-1.2646
2	-0.293	-0.2881	0.918	-0.415	52	0.3516	0.332	1.1426	-0.1514	102	-0.332	0.1074	0.8545	-0.8594	152	0.6152	-0.249	1.1719	-0.4688
3	-0.3125	-0.249	0.9033	-0.6592	53	0.9814	0.1514	1.1621	-0.3516	103	-0.3223	0.2783	0.8545	-0.0146	153	0.332	-0.2783	0.9277	-0.1709
4	-0.3174	-0.2002	0.8691	0.1416	54	1.416	-0.0391	1.2012	0.4346	104	-0.3271	0.4395	-3.9844	-1.4355	154	0.1123	-0.3027	1.1279	0.0635
5	-0.3223	-0.0879	-6.1816	-1.9678	55	1.5967	-0.1758	-9.4482	-2.8467	105	-0.3271	0.5957	0.8447	-0.6396	155	-0.2588	-0.3174	1.1182	0.0879
6	-0.3271	0.0732	0.8252	-1.0352	56	1.5137	-0.2393	1.1914	-1.416	106	-0.3223	0.7227	0.8594	-0.5859	156	-0.249	-0.332	1.1084	0.3613
7	-0.332	0.249	0.835	-1.0693	57	1.1621	-0.2783	1.1816	-0.5859	107	-0.3076	0.835	0.8838	0.1172	157	-0.1367	-0.3369	-0.9668	-0.2783
8	-0.3271	0.4053	0.791	-0.0586	58	0.4297	-0.2979	-0.9326	-0.7764	108	-0.3174	0.918	-2.5684	-0.8936	158	-0.2344	-0.3418	1.04	-0.0049
9	-0.3223	0.5762	-10	-4.0967	59	-0.0928	-0.3125	1.123	-0.3125	109	-0.3027	0.9717	0.9131	-0.2832	159	-0.2686	-0.3369	1.0254	-0.2637
10	-0.332	0.708	0.8154	-2.3633	60	-0.0439	-0.3174	1.1377	-0.2344	110	-0.293	0.9863	0.9473	-0.498	160	-0.293	-0.3271	0.9961	0.2979
11	-0.3271	0.8301	0.9375	-0.9668	61	-0.2588	-0.3271	1.0938	0.2002	111	-0.293	0.957	1.001	0.3467	161	-0.3076	-0.3027	-4.5068	-1.4307
12	-0.3174	0.9033	-0.1904	-0.8057	62	-0.2441	-0.3271	-4.6533	-1.4697	112	-0.2588	0.8838	-4.5361	-1.3574	162	-0.2881	-0.2881	0.918	-0.6836
13	-0.3271	0.9619	-5.4395	-2.3779	63	-0.2637	-0.3271	1.0205	-0.7275	113	-0.0342	0.7764	1.0498	-0.4932	163	-0.3174	-0.2441	0.9082	-0.9424
14	-0.3027	0.9668	0.9277	-1.3965	64	-0.2539	-0.3174	1.0156	-0.791	114	0.332	0.6348	1.0938	-0.0879	164	-0.3174	-0.1807	0.8789	0.0635
15	-0.3223	0.9473	0.9473	-0.3809	65	-0.2734	-0.3027	0.957	0.0293	115	0.3711	0.4736	1.1621	0.2197	165	-0.3369	-0.0586	-7.9688	-2.6367
16	-0.2979	0.874	-1.3379	-0.8105	66	-0.293	-0.2832	-9.9707	-3.2373	116	0.459	0.3027	-7.0557	-2.2168	166	-0.3223	0.1074	0.8545	-1.3428
17	-0.2344	0.7764	0.9961	-0.2441	67	-0.3125	-0.2539	0.8936	-1.8262	117	1.0791	0.1172	1.1768	-0.9668	167	-0.3271	0.2734	0.8545	-1.3184
18	-0.0879	0.6348	1.0352	-0.293	68	-0.3125	-0.1855	0.8936	-0.8398	118	1.5234	-0.0635	1.2012	-0.3516	168	-0.3223	0.4297	0.835	-0.1318
19	0.1855	0.4883	1.0889	0.3174	69	-0.3223	-0.083	0.8447	-0.4883	119	1.6553	-0.1758	0.5957	-0.1465	169	-0.332	0.5811	-8.3838	-2.8564
20	0.2148	0.3174	-3.3789	-1.0156	70	-0.3271	0.0928	-10	-4.0332	120	1.5332	-0.249	1.167	0.0732	170	-0.3223	0.7178	0.8545	-1.4355
21	0.0195	0.1563	1.1279	-0.332	71	-0.332	0.2539	0.8252	-2.3291	121	1.1475	-0.2783	1.1865	-0.1611	171	-0.3271	0.835	0.8789	-1.2744
22	0.2344	-0.0342	1.1475	-0.3613	72	-0.332	0.4248	0.8301	-1.0645	122	0.4248	-0.3027	1.1621	0.4199	172	-0.3223	0.9326	0.8984	-0.1123
23	0.5518	-0.1611	1.1719	0.3076	73	-0.3223	0.5762	-1.5771	-1.3232	123	-0.1074	-0.3174	-5.7715	-1.6553	173	-0.3564	0.9863	-8.8037	-2.959
24	0.5469	-0.2344	-4.3896	-1.3428	74	-0.332	0.7227	0.8203	-0.6152	124	-0.0635	-0.3271	1.1035	-0.7861	174	-0.3027	0.9961	0.9424	-1.4844
25	0.3125	-0.2686	1.1426	-0.542	75	-0.332	0.8301	0.835	-0.5664	125	-0.2588	-0.3271	1.1035	-0.2393	175	-0.2881	0.9521	0.9814	-0.6543
26	0.1514	-0.293	1.1475	-0.6152	76	-0.3223	0.9229	0.8789	0.1514	126	-0.2539	-0.3369	1.0498	-0.0586	176	-0.2539	0.874	1.0205	-0.1807
27	-0.1367	-0.3076	1.1328	0.2148	77	-0.2979	0.9668	-1.6211	-0.5811	127	-0.2539	-0.332	-10	-3.8135	177	-0.0977	0.7568	-6.9629	-2.5537
28	-0.2979	-0.3223	-5.3857	-1.709	78	-0.3271	0.9863	0.9082	-0.1221	128	-0.249	-0.3223	0.9766	-2.1484	178	0.2393	0.625	1.084	-1.2939
29	-0.1758	-0.3223	1.0645	-0.7959	79	-0.3174	0.9473	0.9424	-0.332	129	-0.2881	-0.3027	0.8447	-1.0449	179	0.3174	0.4688	1.123	-0.4492
30	-0.3027	-0.3271	1.0498	-0.2832	80	-0.3174	0.8838	0.9961	0.3662	130	-0.2881	-0.2832	-0.5322	-1.0498	180	0.2246	0.3027	1.1475	-0.0244
31	-0.3125	-0.3271	1.0156	-0.0684	81	-0.2246	0.7764	-3.1543	-0.9131	131	-0.3076	-0.2441	0.8984	-0.4834	181	0.874	0.127	1.1426	0.1465
32	-0.2734	-0.3174	-10	-3.9258	82	-0.0146	0.6445	1.04	-0.2734	132	-0.3223	-0.1807	0.8691	-0.4785	182	1.2939	-0.0635	1.1768	0.1074
33	-0.2979	-0.3027	0.957	-2.1973	83	0.2539	0.4834	1.0889	-0.4395	133	-0.3271	-0.0537	0.8838	0.0977	183	1.3574	-0.1855	1.1865	0.4248
34	-0.3027	-0.2832	0.9521	-1.0303	84	0.166	0.3125	1.1279	0.3662	134	-0.3174	0.1172	-1.4209	-0.6104	184	1.1768	-0.249	-4.3555	-1.2109
35	-0.3076	-0.249	-1.4697	-1.3037	85	-0.0586	0.1221	-5.8057	-1.7285	135	-0.332	0.2832	0.8252	-0.1904	185	0.7471	-0.2881	1.1572	-0.5127
36	-0.3125	-0.1953	0.8789	-0.6494	86	0.4248	-0.0586	1.1475	-0.7324	136	-0.332	0.4395	0.8154	-0.4297	186	0.332	-0.3027	1.167	-0.0439
37	-0.3271	-0.0879	0.874	-0.542	87	0.835	-0.1807	1.1621	-0.2197	137	-0.3369	0.5908	0.8301	0.2393	187	-0.1758	-0.3223	1.1426	0.0977
38	-0.3271	0.0781	0.8887	0.0488	88	0.6641	-0.2441	1.1768	0.0635	138	-0.3174	0.7178	-5.7666	-1.8213	188	-0.293	-0.332	-7.9053	-2.5146
39	-0.332	0.2393	-0.7227	-0.4053	89	0.4541	-0.2783	-9.8193	-3.1494	139	-0.332	0.8398	0.8643	-0.8252	189	-0.0391	-0.3418	1.0693	-1.3428
40	-0.3271	0.4053	0.8398	-0.0732	90	0.0977	-0.2979	1.1426	-1.5918	140	-0.3271	0.9229	0.8691	-0.791	190	-0.2979	-0.3418	1.0938	-0.5078
41	-0.3271	0.5664	0.8496	-0.1123	91	-0.2393	-0.3174	1.1377	-0.7129	141	-0.3076	0.9961	0.8936	0.0879	191	-0.2832	-0.3418	0.4297	-0.4297
42	-0.332	0.7031	0.8691	0.3027	92	-0.249	-0.3271	1.1328	-0.2734	142	-0.3125	1.001	-6.1475	-2.0068	192	-0.3271	-0.3223	0.9912	-0.0977
43	-0.3369	0.8203	0.5078	0.166	93	-0.0879	-0.332	1.0693	-0.0195	143	-0.3125	0.9766	0.9424	-0.9082	193	-0.2734	-0.3076	0.9521	-0.2246
44	-0.3271	0.9082	-10	-3.8574	94	-0.2344	-0.332	1.0547	-0.0977	144	-0.249	0.8887	0.9814	-0.957	194	-0.3174	-0.2783	0.957	0.2295
45	-0.3174	0.957	0.9131	-2.207	95	-0.249	-0.332	1.0352	0.2588	145	-0.1953	0.7764	1.0254	0.1416	195	-0.3125	-0.249	-3.0811	-1.0693
46	-0.3223	0.9717	0.957	-0.8252	96	-0.3076	-0.3223	-0.9131	-0.3467	146	0.0342	0.625	-9.1064	-2.8857	196	-0.3125	-0.1807	0.8789	-0.459
47	-0.3076	0.9424	-0.9375	-0.957	97	-0.2734	-0.3076	0.957	-0.0635	147	0.2783	0.4688	1.084	-1.416	197	-0.3223	-0.0586	0.8496	-0.5322
48	-0.2686	0.874	1.0059	-0.3125	98	-0.2979	-0.2832	0.9326	-0.3564	148	0.2002	0.293	1.1133	-0.5762	198	-0.332	0.1123	0.8496	0.0977
49	-0.1172	0.7715	1.0449	-0.3516	99	-0.3174	-0.249	0.9131	0.2393	149	0.0537	0.1123	1.1475	-0.1367	199	-0.3271	0.2686	-3.9258	-1.3721
50	0.2734	0.6494	1.1133	0.3271	100	-0.3076	-0.1855	-5.6006	-1.8115	150	0.459	-0.0732	-6.9629	-2.5146	200	-0.332	0.4346	0.8301	-0.6055



Tinggi Gel 4 cm  
Periode 1.7 dt

No	Load cell (Volt)	Seasim (Volt)	Trimmer 1 (Volt)	Trimmer 2 (Volt)	No	Load cell (Volt)	Seasim (Volt)	Trimmer 1 (Volt)	Trimmer 2 (Volt)	No	Load cell (Volt)	Seasim (Volt)	Trimmer 1 (Volt)	Trimmer 2 (Volt)	No	Load cell (Volt)	Seasim (Volt)	Trimmer 1 (Volt)	Trimmer 2 (Volt)
1	-0.0879	-0.2686	1.1377	0.1709	51	-0.2637	0.3662	0.7422	-0.8838	101	1.9775	-0.1025	1.2207	0.2002	151	-0.249	-0.0391	0.8887	-0.4492
2	-0.0928	-0.3125	1.123	0.5713	52	-0.2588	0.5371	0.7373	-0.0195	102	1.084	-0.2148	1.1963	0.5762	152	-0.2588	0.1465	0.8838	0.0391
3	-0.0684	-0.3223	-4.1846	-1.1377	53	-0.2588	0.6934	-7.1045	-2.334	103	0.2686	-0.2734	-8.96	-2.5293	153	-0.2588	0.3223	-1.5283	-0.5762
4	-0.1318	-0.3418	1.0693	-0.4443	54	-0.2588	0.8105	0.7666	-1.2549	104	0.0098	-0.3174	1.1328	-1.2842	154	-0.2539	0.498	0.8838	-0.2295
5	-0.1074	-0.3467	1.0547	-0.083	55	-0.2686	0.9033	0.835	-0.498	105	-0.1465	-0.3271	1.1816	-0.4541	155	-0.249	0.6592	0.9229	-0.459
6	-0.1855	-0.3613	0.5518	-0.0635	56	-0.2686	0.9619	-0.4785	-0.5957	106	-0.1123	-0.3516	-0.3076	-0.6055	156	-0.2783	0.7959	0.9473	0.2832
7	-0.1904	-0.3613	0.9863	0.083	57	-0.2344	1.0059	0.8594	-0.1709	107	-0.1367	-0.3613	1.0205	-0.1758	157	-0.2637	0.8984	-8.7354	-2.6074
8	-0.1953	-0.3662	0.957	-0.083	58	-0.2441	1.0107	0.8984	-0.249	108	-0.1563	-0.3809	0.9863	-0.4297	158	-0.2441	0.9619	1.0107	-1.3037
9	-0.1807	-0.3564	0.9375	0.2588	59	-0.249	0.9912	0.9619	0.3125	109	-0.1807	-0.3857	0.9619	0.2051	159	-0.1807	0.9961	1.1182	-0.4248
10	-0.21	-0.3467	-6.5381	-2.0557	60	-0.1563	0.9277	-3.5156	-1.0498	110	-0.2246	-0.3906	-9.209	-2.9834	160	0.1025	1.001	-0.0635	-0.4248
11	-0.2295	-0.3271	0.9033	-1.084	61	-0.1074	0.8447	1.0205	-0.3467	111	-0.21	-0.376	0.8838	-1.582	161	0.5078	0.9814	1.1084	0.0488
12	-0.2246	-0.3027	0.8887	-0.4785	62	0.0098	0.7178	1.0498	0.0049	112	-0.2197	-0.3516	0.835	-0.835	162	0.6104	0.9424	1.1475	-0.0342
13	-0.249	-0.249	0.8643	-0.2295	63	0.293	0.5811	1.0693	0.2197	113	-0.2393	-0.3271	-1.167	-1.0303	163	1.2207	0.8594	1.1865	0.5322
14	-0.2441	-0.1709	-10	-3.9258	64	0.2148	0.4248	1.0791	0.3174	114	-0.2637	-0.3027	0.7715	-0.5908	164	2.1289	0.7422	-6.8213	-1.9141
15	-0.2637	-0.0098	0.8643	-2.1729	65	0.0098	0.2637	1.1182	0.2637	115	-0.2686	-0.249	0.7764	-0.6641	165	2.7588	0.5859	1.2109	-0.7764
16	-0.2588	0.1807	0.874	-1.0645	66	-0.1416	0.0781	1.1279	0.5127	116	-0.2783	-0.166	0.7373	-0.0488	166	3.208	0.4102	1.2402	-0.1563
17	-0.2588	0.3662	0.8301	-0.5615	67	-0.0977	-0.0977	-0.083	0.1416	117	-0.2686	-0.0195	-5.6396	-1.9141	167	3.2031	0.2344	0.415	-0.0586
18	-0.2393	0.5322	-10	-4.4092	68	0.0146	-0.2148	1.0986	0.2539	118	-0.2588	0.1611	0.7959	-1.0303	168	2.9053	0.0635	1.2109	0.166
19	-0.2393	0.6885	0.9082	-2.5684	69	-0.1465	-0.2734	1.1182	0.0635	119	-0.2734	0.332	0.7471	-1.0889	169	2.0459	-0.1025	1.2207	0.0342
20	-0.2197	0.8105	0.9424	-1.1475	70	-0.1563	-0.3174	1.1035	0.4297	120	-0.2637	0.4932	0.7129	-0.0977	170	1.1133	-0.2002	1.2012	0.4639
21	-0.2246	0.918	-4.0332	-2.0752	71	-0.1807	-0.3271	-6.4209	-1.8701	121	-0.2686	0.6445	-9.0479	-2.9639	171	0.2979	-0.2734	1.167	0.5127
22	-0.1855	0.9814	0.9912	-0.9961	72	-0.1709	-0.3516	1.0449	-0.9717	122	-0.2686	0.7764	0.7568	-1.6699	172	0.0098	-0.3125	1.1426	0.3076
23	-0.1221	1.0205	1.04	-0.9424	73	-0.1758	-0.3564	1.0693	-0.2979	123	-0.2539	0.8838	0.8057	-0.6982	173	-0.1074	-0.332	1.1133	0.5713
24	0.0586	1.0205	1.0791	0.1221	74	-0.2002	-0.3809	0.249	-0.3418	124	-0.2637	0.957	-1.3965	-1.0254	174	-0.1074	-0.3516	-2.6172	-0.6934
25	0.4248	0.9863	-10	-3.2031	75	-0.2197	-0.376	0.9766	-0.0586	125	-0.2441	0.9961	0.8594	-0.3906	175	-0.127	-0.3711	1.0303	-0.1953
26	0.5615	0.918	1.1426	-1.5918	76	-0.2148	-0.3857	0.9375	-0.2979	126	-0.2441	1.0059	0.8887	-0.4639	176	-0.1465	-0.3906	0.9961	-0.6006
27	0.9766	0.8301	1.1865	-0.5615	77	-0.2051	-0.3711	0.9375	0.2246	127	-0.2539	0.9912	0.9521	0.2295	177	-0.1709	-0.4004	0.9521	0.249
28	1.9531	0.708	-1.6895	-0.9619	78	-0.2246	-0.3516	-8.0762	-2.5977	128	-0.2051	0.9375	-5.1318	-1.6211	178	-0.1953	-0.4004	-10	-4.0381
29	2.6855	0.5762	1.2061	-0.2881	79	-0.2441	-0.3271	0.8984	-1.3818	129	-0.1465	0.8643	1.0107	-0.6543	179	-0.2197	-0.376	0.8789	-2.2656
30	3.1152	0.4199	1.2305	0.1025	80	-0.2441	-0.3076	0.8838	-0.6787	130	-0.0537	0.7422	1.0303	-0.21	180	-0.249	-0.3516	0.918	-1.1035
31	3.2715	0.2637	1.2402	0.3076	81	-0.2588	-0.249	0.8496	-0.3223	131	0.1611	0.5859	1.0596	0.1074	181	-0.2539	-0.3271	-2.9785	-1.7627
32	2.9785	0.0781	1.2012	0.415	82	-0.2539	-0.166	-10	-4.248	132	0.1367	0.4102	1.0645	0.2148	182	-0.2588	-0.3027	0.8105	-0.9961
33	2.2119	-0.0977	1.2109	0.2246	83	-0.249	0	0.874	-2.334	133	-0.083	0.2344	1.1133	0.1172	183	-0.2588	-0.249	0.7959	-1.1182
34	1.2842	-0.2148	1.2061	0.5518	84	-0.2539	0.1807	0.8789	-1.1865	134	-0.1514	0.0488	1.1182	0.4297	184	-0.2686	-0.1709	0.752	-0.1465
35	0.4297	-0.2734	-6.6846	-1.8848	85	-0.2588	0.3662	0.625	-0.6641	135	-0.1465	-0.1172	-2.2168	-0.5518	185	-0.2588	-0.0342	-9.1211	-3.0664
36	0.0439	-0.3125	1.1426	-0.8545	86	-0.2441	0.5273	0.8936	-0.3027	136	-0.0684	-0.2148	1.1084	-0.1611	186	-0.2734	0.1514	0.7324	-1.7432
37	-0.1416	-0.3271	1.123	-0.2881	87	-0.2441	0.6787	0.9229	-0.3174	137	-0.166	-0.2686	1.1133	-0.3857	187	-0.2637	0.332	0.7471	-1.4697
38	-0.1514	-0.3467	0.8008	-0.127	88	-0.2246	0.7959	0.9424	0.2051	138	-0.127	-0.3125	1.0791	0.3125	188	-0.2588	0.5029	0.6641	-0.3418
39	-0.1904	-0.3564	1.0303	0.0684	89	-0.21	0.9033	-4.668	-1.416	139	-0.1855	-0.332	0.9277	0.3369	189	-0.2832	0.6592	-10	-2.4322
40	-0.1953	-0.3711	0.9961	-0.1611	90	-0.1953	0.9619	0.9961	-0.6201	140	-0.1807	-0.3516	1.04	0.0684	190	-0.2734	0.7813	0.7715	-2.4854
41	-0.21	-0.3711	0.9619	0.2783	91	-0.1172	1.0059	1.0547	-0.0879	141	-0.1807	-0.3613	1.0449	0.4199	191	-0.2637	0.8789	0.8057	-1.0742
42	-0.1953	-0.376	-7.2949	-2.3047	92	0.1123	1.0059	1.0742	0.1367	142	-0.1904	-0.3857	-2.3389	-0.7227	192	-0.2539	0.9424	-3.3936	-1.875
43	-0.2197	-0.3662	0.8838	-1.2061	93	0.5127	0.9863	1.1084	0.376	143	-0.21	-0.3906	0.9668	-0.2393	193	-0.2344	0.9766	0.8643	-0.8936
44	-0.2393	-0.3467	0.8398	-0.6055	94	0.5518	0.9326	1.0352	0.3076	144	-0.2441	-0.3955	0.9424	-0.6641	194	-0.21	0.9912	0.9082	-0.9424
45	-0.249	-0.3271	-0.0244	-0.5664	95	1.2305	0.8594	1.1914	0.6006	145	-0.21	-0.376	0.9277	0.2246	195	-0.2295	0.9814	0.9473	0.0732
46	-0.249	-0.3027	0.7764	-0.2881	96	2.1143	0.7373	-2.9639	-0.6885	146	-0.2246	-0.3516	-10	-4.0381	196	-0.2148	0.9424	-8.0664	-2.6123
47	-0.2637	-0.249	0.7764	-0.4736	97	2.6465	0.6055	1.2109	-0.0488	147	-0.2344	-0.3271	0.9033	-2.2949	197	-0.1221	0.8545	1.0156	-1.2598
48	-0.2539	-0.1709	0.752	0.0732	98	3.208	0.4297	1.2256	0.2295	148	-0.2393	-0.2979	0.9033	-1.0938	198	0.0244	0.7227	1.0645	-0.5029
49	-0.2637	-0.0146	-4.6777	-1.5771	99	3.1689	0.2637	1.2402	0.4346	149	-0.249	-0.249	-0.8643	-1.0938	199	0.2441	0.5615	-0.4932	-0.5713
50	-0.2637	0.1807	0.7275	-0.8154	100	2.8613	0.0684	1.2061	0.4541	150	-0.2539	-0.1709	0.8545	-0.6055	200	0.1514	0.3857	1.0791	-0.166



Tinggi Gel 4 cm  
Periode 1.8 dt

No	Load cell (Volt)	Seasim (Volt)	Trimmeter 1 (Volt)	Trimmeter 2 (Volt)	No	Load cell (Volt)	Seasim (Volt)	Trimmeter 1 (Volt)	Trimmeter 2 (Volt)	No	Load cell (Volt)	Seasim (Volt)	Trimmeter 1 (Volt)	Trimmeter 2 (Volt)	No	Load cell (Volt)	Seasim (Volt)	Trimmeter 1 (Volt)	Trimmeter 2 (Volt)	No	Load cell (Volt)	Seasim (Volt)	Trimmeter 1 (Volt)	Trimmeter 2 (Volt)
1	-0.1318	-0.2979	-7.5537	-2.1875	51	-0.2051	0.0439	0.8838	-0.4688	101	0.2393	0.6348	1.1279	0.415	151	-0.1904	-0.3662	0.8057	-0.8496	152	-0.1855	-0.3662	-4.0234	-1.9971
2	-0.1123	-0.3125	1.0254	-1.1035	52	-0.2002	0.2246	0.9033	0.1758	102	0.5322	0.4932	1.1621	0.2588	153	-0.2051	-0.3418	0.7373	-1.0742	154	-0.2002	-0.3271	0.7227	-1.2598
3	-0.0977	-0.3271	0.9814	-0.4541	53	-0.21	0.3955	-9.4873	-2.9785	103	0.7813	0.3418	1.1719	0.5908	155	-0.21	-0.2979	0.3174	-0.3027	156	-0.2002	-0.2637	0.6592	-0.2002
4	-0.1318	-0.3369	-1.1621	-0.8301	54	-0.1758	0.5566	0.9375	-1.6309	104	0.5908	0.1758	-4.8389	-1.2793	157	-0.2051	-0.2002	0.6689	-0.542	158	-0.21	-0.0977	0.6543	0.0732
5	-0.127	-0.3516	0.8887	-0.3906	55	-0.2197	0.7031	0.9912	-0.6201	105	0.3174	0.0049	1.1572	-0.4688	159	-0.1904	0.0879	-10	-4.0674	160	-0.1904	0.2588	0.6934	-2.5244
6	-0.1758	-0.3564	0.8691	-0.625	56	-0.1758	0.8252	-0.3906	-0.625	106	0.2734	-0.1416	1.1572	-0.0635	161	-0.2002	0.4395	0.7227	-1.0449	162	-0.2002	0.5908	-4.3652	-2.168
7	-0.1855	-0.3516	0.8154	0.083	57	-0.0879	0.9229	1.0303	-0.1465	107	-0.0781	-0.2246	1.1426	0.1514	163	-0.1953	0.7373	0.7666	-1.1035	164	-0.1758	0.8447	0.8057	-0.542
8	-0.1807	-0.3467	-10	-4.1064	58	0.1123	0.9863	1.084	-0.4053	108	-0.1416	-0.2734	1.0986	0.249	165	-0.2148	0.9229	0.8203	-0.1758	166	-0.1855	0.9619	-6.2256	-2.3193
9	-0.21	-0.332	0.7666	-2.4463	59	0.4395	1.0205	1.123	0.4785	109	-0.0098	-0.3027	1.0791	0.0439	167	-0.1563	0.9912	0.9375	-1.3672	168	-0.1514	0.9961	1.0059	-0.4199
10	-0.1953	-0.3174	0.7861	-1.1426	60	0.6689	1.0254	-8.7305	-2.4854	110	-0.127	-0.3174	1.0693	0.3955	169	-0.0928	0.9814	-3.374	-1.377	170	-0.0928	0.9814	-3.374	-1.377
11	-0.2051	-0.3027	-3.2617	-1.9043	61	1.0156	0.9961	1.167	-1.2109	111	-0.1514	-0.3369	-8.0908	-2.4268	171	0.3662	0.8691	1.0986	-0.0586	172	0.3027	0.7568	1.123	0.1416
12	-0.2002	-0.2734	0.7129	-1.0596	62	1.8408	0.9375	1.2061	-0.3223	112	-0.1563	-0.3467	1.0107	-1.2695	173	0.1123	0.6299	1.1328	0.3564	174	0.4541	0.4736	1.1523	0.1904
13	-0.2148	-0.2246	0.7275	-1.2109	63	2.6367	0.8545	-3.7305	-1.4258	113	-0.1318	-0.3564	0.9863	-0.5518	175	0.7422	0.3223	1.0791	0.5371	176	0.5762	1.485	-5.0732	-1.416
14	-0.2002	-0.1367	0.0586	-0.3711	64	3.3008	0.7471	1.2256	-0.5176	114	-0.1318	-0.3662	-0.0977	-0.5908	177	0.3369	-0.0244	1.1572	-0.5273	178	0.2588	-0.166	1.1523	-0.127
15	-0.1953	0.0342	-5.791	-2.3145	65	3.4375	0.625	1.2402	-0.0049	115	-0.1514	-0.3662	0.918	-0.2393	179	-0.0732	-0.2344	1.1426	0.1318	180	-0.1563	-0.2881	1.0938	0.2051
16	-0.1758	0.2246	0.7275	-1.5234	66	3.2031	0.4834	1.2451	0.2539	116	-0.1611	-0.3564	0.9131	-0.6592	181	-0.0293	-0.3076	1.0938	0.2051	182	-0.1514	-0.3271	1.0791	0.376
17	-0.21	0.4004	0.7471	-0.5078	67	2.4609	0.3369	1.2305	0.4102	117	-0.1611	-0.3369	0.8887	0.1953	183	-0.1709	-0.3369	-8.6035	-2.5732	184	-0.1758	-0.3516	1.001	-1.3965
18	-0.21	0.5518	-4.707	-1.9092	68	1.543	0.1807	1.2061	0.0488	118	-0.1807	-0.3223	-10	-3.4668	185	-0.1416	-0.3613	0.9961	-0.5908	186	-0.1514	-0.376	-0.2734	-0.6982
19	-0.2148	0.6934	0.7861	-1.0059	69	0.5811	0.0146	1.1963	0.6055	119	-0.1855	-0.3027	0.874	-1.9141	187	-0.1611	-0.3711	0.9277	-0.2734	188	-0.1807	-0.3662	0.8984	-0.7373
20	-0.21	0.8154	0.8398	-0.3906	70	0.0732	-0.1318	0.9473	0.3955	120	-0.2002	-0.2686	0.874	-0.9521	189	-0.1855	-0.3418	0.9033	0.1953	190	-0.1904	-0.3271	-10	-3.7695
21	-0.2002	0.918	0.8154	-0.1221	71	0.0244	-0.2148	1.123	0.3271	121	-0.2002	-0.21	0.3271	-0.6543	191	-0.1953	-0.3027	0.8887	-2.0801	192	-0.2002	-0.2637	0.874	-1.0547
22	-0.2441	0.9961	0.9229	0.1025	72	-0.0781	-0.2637	1.0986	0.498	122	-0.1953	-0.1025	0.8691	-0.3174	193	-0.2002	-0.1953	0.2783	0.9082	194	-0.2002	-0.0781	0.8643	-0.4639
23	-0.2002	1.04	0.9473	-0.0586	73	-0.0732	-0.3027	-3.6035	-0.9961	123	-0.1855	0.0684	0.8887	-0.3027	195	-0.1855	0.1123	0.8984	-0.4541	196	-0.1855	0.1123	0.8984	-0.4541
24	-0.1709	1.0449	1.0059	0.4346	74	-0.0879	-0.3174	1.0107	-0.415	124	-0.1855	0.2393	0.9082	0.1172	197	-0.1904	-0.3271	0.8887	-2.0801	198	-0.1953	-0.3027	0.8887	-2.0801
25	-0.083	1.0156	-4.7803	-1.3232	75	-0.1025	-0.332	0.9717	-0.1123	125	-0.1904	0.415	-5.957	-1.9141	199	-0.1855	-0.3418	0.9033	0.1953	200	-0.1904	-0.3271	-10	-3.7695
26	0.2197	0.9619	1.0693	-0.4932	76	-0.127	-0.3418	0.7568	-0.0488	126	-0.1953	0.5713	0.9473	-0.957	201	-0.1855	-0.3418	0.9033	0.1953	202	-0.1904	-0.3271	-10	-3.7695
27	0.4004	0.8789	1.1084	-0.0098	77	-0.1611	-0.3564	0.8789	0.0635	127	-0.2148	0.7227	0.9863	-0.3076	203	-0.1855	-0.3418	0.9033	0.1953	204	-0.1904	-0.3271	-10	-3.7695
28	0.3955	0.7715	1.1426	0.2344	78	-0.1709	-0.3613	0.8594	-0.1807	128	-0.1855	0.8398	1.0107	-0.0293	205	-0.1855	-0.3418	0.9033	0.1953	206	-0.1904	-0.3271	-10	-3.7695
29	0.3418	0.6494	1.1621	0.3955	79	-0.1758	-0.3662	0.8252	0.21	129	-0.0732	0.9277	1.0352	0.2246	207	-0.1855	-0.3418	0.9033	0.1953	208	-0.1904	-0.3271	-10	-3.7695
30	0.7959	0.5029	1.1719	0.166	80	-0.1904	-0.3564	-8.3545	-2.6611	130	0.1709	0.9668	1.0938	0	209	-0.1855	-0.3418	0.9033	0.1953	210	-0.1904	-0.3271	-10	-3.7695
31	1.0498	0.3467	1.1816	0.6055	81	-0.21	-0.3369	0.7568	-1.499	131	0.5713	0.9863	1.0742	0.5518	211	-0.1855	-0.3418	0.9033	0.1953	212	-0.1904	-0.3271	-10	-3.7695
32	0.918	0.1807	-8.6328	-2.417	82	-0.21	-0.3223	0.7471	-0.752	132	0.6738	0.9814	-5.1221	-1.3525	213	-0.1855	-0.3418	0.9033	0.1953	214	-0.1904	-0.3271	-10	-3.7695
33	0.7666	0.0098	1.1621	-1.2305	83	-0.21	-0.3027	-1.0449	-0.9717	133	1.2061	0.9619	1.1719	-0.459	215	-0.1855	-0.3418	0.9033	0.1953	216	-0.1904	-0.3271	-10	-3.7695
34	-0.1563	-0.1318	1.1719	-0.3906	84	-0.2002	-0.2734	0.6934	-0.5371	134	2.1729	0.918	1.2207	0.0732	217	-0.1855	-0.3418	0.9033	0.1953	218	-0.1904	-0.3271	-10	-3.7695
35	-0.1025	-0.2148	-0.8887	-0.6836	85	-0.21	-0.2148	0.6885	-0.8789	135	2.9639	0.8545	-0.9473	-0.3076	219	-0.1855	-0.3418	0.9033	0.1953	220	-0.1904	-0.3271	-10	-3.7695
36	0.0537	-0.2637	1.1084	-0.2148	86	-0.2051	-0.1074	0.625	-0.0195	136	3.4668	0.752	1.2305	0.1025	221	-0.1855	-0.3418	0.9033	0.1953	222	-0.1904	-0.3271	-10	-3.7695
37	-0.1855	-0.3027	1.0938	-0.4834	87	-0.2148	0.0684	-10	-4.1309	137	3.5596	0.6299	1.2598	0.3857	223	-0.1855	-0.3418	0.9033	0.1953	224	-0.1904	-0.3271	-10	-3.7695
38	-0.1514	-0.3174	1.0742	0.293	88	-0.2002	0.2393	0.708	-2.5244	138	3.2617	0.4834	1.2549	0.4736	225	-0.1855	-0.3418	0.9033	0.1953	226	-0.1904	-0.3271	-10	-3.7695
39	-0.127	-0.332	1.0205	0.3076	89	-0.2051	0.4102	0.7373	-1.0938	139	2.4121	0.332	1.2061	0.5615	227	-0.1855	-0.3418	0.9033	0.1953	228	-0.1904	-0.3271	-10	-3.7695
40	-0.1172	-0.3369	1.0156	0.1123	90	-0.1807	0.5615	-4.0332	-2.0703	140	1.3867	0.1563	1.2061	0.3174	229	-0.1855	-0.3418	0.9033	0.1953	230	-0.1904	-0.3271	-10	-3.7695
41	-0.1563	-0.3516	0.9863	0.4053	91	-0.2002	0.708	0.7715	-1.0791	141	0.4785	-0.0195	1.1914	0.6299	231	-0.1855	-0.3418	0.9033	0.1953	232	-0.1904	-0.3271	-10	-3.7695
42	-0.1465	-0.3613	-3.5986	-1.0742	92	-0.1953	0.8301	0.8252	-0.4785	142	0.0977	-0.1611	-5.8545	-1.6162	233	-0.1855	-0.3418	0.9033	0.1953	234	-0.1904	-0.3271	-10	-3.7695
43	-0.166	-0.3613	0.918	-0.5078	93	-0.2002	0.9277	0.8447	-0.166	143	-0.0586	-0.2344	1.1182	-0.6738	235	-0.1855	-0.3418	0.9033	0.1953	236	-0.1904	-0.3271	-10	-3.7695
44	-0.1758	-0.3516	0.9131	-0.1563	94	-0.2002	0.9863	0.8887	0.0537	144	-0.0439	-0.2832	1.0889	-0.2295	237	-0.1855	-0.3418	0.9033	0.1953	238	-0.1904	-0.3271	-10	-3.7695
45	-0.1855	-0.332	0.0732	-0.2783	95	-0.2197	1.0156	0.9424	-0.0586	145	-0.0781	-0.3027	-0.5176	-0.4639	239	-0.1855	-0.3418	0.9033	0.1953	240	-0.1904	-0.3271	-10	-3.7695
46	-0.1855	-0.3174	0.874	-0.0732	96	-0.1709	1.0107	1.001	0.3906	146	-0.0977	-0.3271	0.9961	-0.1709	241	-0.1855	-0.3418	0.9033	0.1953	242	-0.1904	-0.3271	-10	-3.7695
47	-0.1953	-0.3027	0.8691	-0.1953	97	-0.0928	0.9814	-3.7256	-1.0205	147	-0.0977	-0.3369	0.9619	-0.4492	243	-0.18								



Tinggi Gel 4 cm  
Periode 1.9 dt

No	Load cell (Volt)	Seasim (Volt)	Trimmeter 1 (Volt)	Trimmeter 2 (Volt)	No	Load cell (Volt)	Seasim (Volt)	Trimmeter 1 (Volt)	Trimmeter 2 (Volt)	No	Load cell (Volt)	Seasim (Volt)	Trimmeter 1 (Volt)	Trimmeter 2 (Volt)	No	Load cell (Volt)	Seasim (Volt)	Trimmeter 1 (Volt)	Trimmeter 2 (Volt)	No	Load cell (Volt)	Seasim (Volt)	Trimmeter 1 (Volt)	Trimmeter 2 (Volt)
1	1.2891	0.4541	1.2891	0.6055	51	-0.1465	-0.4053	0.8594	-1.2207	101	-0.1807	0.3857	0.835	-1.1279	151	2.3291	0.8203	1.2256	-0.1709					
2	0.4834	0.2783	-0.166	0.1758	52	-0.1563	-0.3955	0.8154	-0.1221	102	-0.1709	0.542	0.8691	0.0146	152	1.8604	0.6641	-4.1504	-1.4648					
3	-0.0098	0.0928	1.1475	0.3516	53	-0.166	-0.3955	0.8008	-0.0586	103	-0.1611	0.6934	0.8936	0.1025	153	1.2354	0.498	1.1914	-0.6201					
4	-0.0781	-0.0879	1.1279	-0.0879	54	-0.1709	-0.3613	0.8057	-0.4199	104	-0.1709	0.835	0.957	0.0098	154	0.3955	0.3174	1.1914	-0.0488					
5	0.0781	-0.2051	1.0889	0.5371	55	-0.166	-0.3467	0.7813	-10	105	-0.0928	0.9668	1.0107	0.3906	155	-0.0537	0.1318	-1.4844	-0.6543					
6	-0.0879	-0.2588	1.0303	0.4688	56	-0.1709	-0.3174	-10	-4.0088	106	-0.0439	1.0645	-4.9854	-1.3623	156	0.0342	-0.0537	1.1182	-0.1758					
7	-0.1074	-0.2979	1.0889	0.2295	57	-0.1709	-0.2979	0.7861	-2.5635	107	0.127	1.1377	1.0693	-0.5566	157	-0.1074	-0.1904	1.1279	0.0732					
8	-0.1563	-0.3223	0.9717	0.4395	58	-0.166	-0.2441	0.8008	-1.1133	108	0.5127	1.167	1.1182	0.0293	158	-0.0537	-0.2588	1.0498	0.1758					
9	-0.1025	-0.3418	-6.2061	-1.8457	59	-0.1611	-0.1758	-10	-4.2871	109	0.6299	1.1572	1.1377	0.2393	159	-0.0635	-0.3027	1.0059	0.2246					
10	-0.1318	-0.3613	0.8936	-0.9668	60	-0.1611	-0.0391	0.835	-2.4658	110	0.8545	1.1084	1.1621	0.4688	160	-0.0635	-0.3271	0.9863	-0.0195					
11	-0.1367	-0.3809	0.8643	-0.4199	61	-0.1611	0.1172	0.8691	-1.2109	111	1.626	1.0303	1.1914	0.2783	161	-0.0977	-0.3467	0.9473	0.3174					
12	-0.1367	-0.3955	-1.0596	-0.7813	62	-0.1611	0.2783	-1.4844	-1.3232	112	2.1875	0.9277	1.2158	0.708	162	-0.1172	-0.376	-8.2568	-2.5635					
13	-0.1611	-0.3955	0.7861	-0.3906	63	-0.1611	0.4297	0.8887	-0.6934	113	2.3779	0.791	1.1865	0.6641	163	-0.127	-0.4053	0.874	-1.4111					
14	-0.1758	-0.3906	0.7666	-0.7568	64	-0.1318	0.5762	0.9521	-0.8594	114	2.2168	0.6396	1.2158	0.3564	164	-0.1563	-0.415	0.8496	-0.6738					
15	-0.166	-0.3809	0.7471	0.0586	65	-0.1416	0.7129	0.9668	0.1318	115	1.6992	0.4736	1.2207	0.7324	165	-0.166	-0.415	-2.2705	-1.3232					
16	-0.1758	-0.3564	-10	-3.5547	66	-0.0879	0.8496	-10	-3.6084	116	1.0596	0.2979	1.1768	0.7178	166	-0.1709	-0.415	0.7861	-0.7129					
17	-0.166	-0.3369	0.7178	-2.1338	67	0.0098	0.9619	1.0498	-2.0557	117	0.2588	0.1123	1.1719	0.3662	167	-0.1758	-0.4102	0.7715	-1.001					
18	-0.1709	-0.3174	0.7275	-0.9961	68	0.2393	1.0645	1.1182	-0.7227	118	-0.0684	-0.0732	1.167	0.6836	168	-0.1807	-0.3857	0.7373	-0.0488					
19	-0.166	-0.2979	-4.6826	-2.251	69	0.5615	1.1377	-3.0469	-1.5137	119	0.083	-0.1904	-4.0674	-1.0449	169	-0.1807	-0.3564	-10	-4.1943					
20	-0.1709	-0.2539	0.7129	-1.2598	70	0.6152	1.1768	1.1621	-0.542	120	-0.1221	-0.2539	1.0791	-0.3711	170	-0.166	-0.332	0.7471	-2.4658					
21	-0.1758	-0.1953	0.752	-1.3086	71	1.2988	1.1719	1.1816	-0.0586	121	-0.0928	-0.293	1.0791	-0.0488	171	-0.1758	-0.3125	0.7471	-1.2207					
22	-0.1709	-0.0635	0.7275	-0.21	72	2.0947	1.1328	0.4492	0.0635	122	-0.0586	-0.3223	-0.5566	-0.3662	172	-0.1709	-0.2734	-1.9287	-1.543					
23	-0.1758	0.1123	-10	-4.2725	73	2.4414	1.0498	1.1914	0.2881	123	-0.0928	-0.3467	0.9766	-0.1221	173	-0.1758	-0.2197	0.7861	-0.8447					
24	-0.1611	0.2832	0.791	-2.5977	74	2.7637	0.9375	1.2354	0.5225	124	-0.0928	-0.3662	0.9521	-0.4834	174	-0.1758	-0.1123	0.7861	-1.0254					
25	-0.1611	0.4443	0.8252	-1.1719	75	2.5732	0.7959	1.2256	0.542	125	-0.1123	-0.3955	0.9033	0.2148	175	-0.1904	0.0488	0.7813	-0.0684					
26	-0.1465	0.6104	-5.2783	-2.4756	76	1.9775	0.6396	1.2109	0.6348	126	-0.1123	-0.4102	-10	-3.9893	176	-0.166	0.2197	-10	-4.1406					
27	-0.1465	0.752	0.8984	-1.3037	77	1.167	0.4688	1.1914	0.1563	127	-0.1416	-0.415	0.8594	-2.3389	177	-0.1904	0.3809	0.8643	-2.3828					
28	-0.1563	0.8838	0.9424	-0.5371	78	0.4199	0.2979	1.1963	0.7324	128	-0.1611	-0.415	0.8496	-1.084	178	-0.1855	0.5371	0.9033	-1.0498					
29	-0.1416	0.9863	0.7178	-0.2539	79	0.0879	0.1123	1.1279	0.6055	129	-0.1709	-0.4053	-4.7363	-2.3633	179	-0.1611	0.6885	-4.7803	-2.2559					
30	-0.083	1.0645	1.0107	0.083	80	-0.0928	-0.0635	1.1328	0.4736	130	-0.166	-0.3809	0.8008	-1.3379	180	-0.0928	0.8301	0.9766	-1.1182					
31	0.0977	1.1182	1.0693	-0.1807	81	-0.0195	-0.1904	1.0889	0.5225	131	-0.166	-0.3516	0.7861	-0.6836	181	-0.0977	0.9619	1.0303	-0.4346					
32	0.4688	1.1426	1.1182	0.5371	82	-0.0977	-0.2539	-4.8682	-1.3232	132	-0.166	-0.3223	-2.9834	-1.5186	182	0.0244	1.0693	1.001	-0.083					
33	0.5762	1.1328	-6.9775	-1.9287	83	-0.0781	-0.3027	0.9961	-0.6396	133	-0.1807	-0.2979	0.7813	-0.8545	183	0.3027	1.1377	1.0889	0.2051					
34	0.5811	1.0986	1.1621	-0.8105	84	-0.1025	-0.3174	0.9863	-0.1855	134	-0.1855	-0.2588	0.8057	-0.3906	184	0.5615	1.1719	1.1377	0.0977					
35	1.2939	1.0205	1.1963	-0.1172	85	-0.1172	-0.3467	-0.1611	-0.415	135	-0.1611	-0.1953	-1.1963	-0.835	185	0.6055	1.167	1.1768	0.5859					
36	1.8164	0.918	-3.0566	-1.0742	86	-0.0977	-0.3662	0.8984	-0.0977	136	-0.166	-0.0781	0.8154	-0.376	186	1.377	1.1279	-7.4805	-2.0361					
37	2.0557	0.7813	1.1914	-0.3516	87	-0.1367	-0.4004	0.8545	-0.4492	137	-0.1807	0.083	0.8447	-0.6201	187	2.1484	1.0596	1.1914	-0.9375					
38	1.9287	0.6396	1.2158	0.1221	88	-0.1563	-0.4053	0.8398	0.1904	138	-0.1807	0.2393	0.8838	0.1563	188	2.6416	0.9619	1.2305	-0.1611					
39	1.499	0.4736	-1.543	-0.5566	89	-0.1611	-0.4053	-10	-3.9893	139	-0.1855	0.3906	-9.0332	-2.8809	189	2.6953	0.8398	-3.6914	-1.3086					
40	0.7422	0.3027	1.0693	-0.0781	90	-0.1758	-0.4053	0.7813	-2.3535	140	-0.1904	0.5518	0.9277	-1.5723	190	2.4316	0.6885	1.2061	-0.4834					
41	0.2637	0.1074	1.1719	0.1758	91	-0.1758	-0.4004	0.7568	-1.1426	141	-0.1514	0.7031	0.9912	-0.6055	191	1.8018	0.5176	1.2207	0.0244					
42	0.0781	-0.0781	1.1182	0.3125	92	-0.1709	-0.3711	-3.6133	-1.9727	142	-0.1465	0.8447	-1.0498	-0.7959	192	0.9131	0.332	-1.2695	-0.5371					
43	-0.0244	-0.2051	1.1084	0.332	93	-0.1611	-0.3516	0.7227	-1.1475	143	-0.0537	0.9717	1.0352	-0.2588	193	0.2734	0.1465	1.167	-0.0635					
44	-0.0146	-0.2588	1.084	-0.0488	94	-0.1758	-0.3223	0.7324	-1.2207	144	0.1563	1.0693	1.0889	0.1221	194	0.0146	-0.0488	1.1523	0.1563					
45	-0.0488	-0.3027	1.0547	0.4395	95	-0.1758	-0.3027	0.7031	-0.2344	145	0.5859	1.1377	1.1328	0.3076	195	-0.0635	-0.1758	1.1182	0.2734					
46	-0.0781	-0.3174	-10	-3.0566	96	-0.1807	-0.2637	-10	-4.2041	146	0.6494	1.167	1.1377	0.4736	196	-0.0586	-0.2539	1.1475	0.3174					
47	-0.0781	-0.3467	0.9717	-1.7285	97	-0.1709	-0.2051	0.7373	-2.5049	147	0.8936	1.1719	1.2012	0.332	197	-0.0781	-0.293	1.04	-0.0439					
48	-0.083	-0.3564	0.9521	-0.7275	98	-0.1709	-0.0879	0.7715	-1.1963	148	1.6309	1.1279	1.2012	0.708	198	-0.083	-0.3271	1.0107	0.4004					
49	-0.1221	-0.3857	-4.375	-2.0361	99	-0.1563	0.0781	-2.9883	-1.875	149	2.2314	1.0547	-7.666	-2.0117	199	-0.0928	-0.3467	-6.9678	-2.0898					
50	-0.1367	-0.3906	0.8887	-1.0449	100	-0.1709	0.2344	0.8008	-0.957	150	2.5244	0.9521	1.2109	-0.9082	200	-0.1172	-0.376	0.9277	-1.2109					



Tinggi Gel 4 cm  
 Periode 2 dt

No	Load cell (Volt)	Seasim (Volt)	Trimmetter 1 (Volt)	Trimmetter 2 (Volt)	No	Load cell (Volt)	Seasim (Volt)	Trimmetter 1 (Volt)	Trimmetter 2 (Volt)	No	Load cell (Volt)	Seasim (Volt)	Trimmetter 1 (Volt)	Trimmetter 2 (Volt)	No	Load cell (Volt)	Seasim (Volt)	Trimmetter 1 (Volt)	Trimmetter 2 (Volt)
1	0.6885	1.1279	1.1816	0.5518	51	-0.0977	-0.0635	-10	-2.8662	101	-0.1904	-0.4248	0.8008	-2.6172	151	-0.2002	0.1563	0.7764	-0.0146
2	1.4014	1.0938	-1.4111	-0.1611	52	-0.1123	-0.1855	1.0254	-1.6553	102	-0.2051	-0.4248	0.7861	-1.1768	152	-0.2002	0.3271	-10	-4.0674
3	2.2021	1.04	1.1963	0.249	53	-0.1221	-0.2588	1.0059	-0.6201	103	-0.2051	-0.415	-10	-4.5654	153	-0.2393	0.4834	0.874	-2.3535
4	2.6855	0.9521	1.2891	0.5029	54	-0.1318	-0.2979	-4.248	-1.9385	104	-0.2197	-0.3857	0.7715	-2.7393	154	-0.1709	0.6348	0.9277	-0.9863
5	2.8809	0.8496	0.9912	0.5273	55	-0.1416	-0.3271	0.9082	-0.9961	105	-0.2197	-0.3613	0.7715	-1.3574	155	-0.1953	0.7715	-4.2676	-2.1045
6	2.5977	0.7227	1.2158	0.6006	56	-0.1758	-0.3467	0.874	-0.5127	106	-0.21	-0.332	-4.9707	-2.5586	156	-0.1807	0.9033	1.0107	-0.957
7	2.041	0.5859	1.2256	0.6543	57	-0.1758	-0.3613	-0.6592	-0.6836	107	-0.21	-0.3125	0.7715	-1.499	157	-0.0732	1.0107	1.0498	-0.376
8	1.1133	0.4395	1.2061	0.6348	58	-0.2051	-0.376	0.791	-0.3906	108	-0.2197	-0.2539	0.791	-0.752	158	0.2637	1.1035	0.8447	-0.0293
9	0.4639	0.2881	1.167	0.6348	59	-0.21	-0.4004	0.7715	-0.752	109	-0.2246	-0.1807	-2.7393	-1.5234	159	0.5273	1.1475	1.123	0.1953
10	-0.0488	0.1172	1.1523	0.1416	60	-0.2197	-0.415	0.7178	0.0391	110	-0.2197	-0.0342	0.8301	-0.7813	160	0.8398	1.1572	1.1768	-0.0244
11	-0.1318	-0.0537	1.1475	0.6787	61	-0.1953	-0.4199	-10	-4.1016	111	-0.2148	0.1416	0.8643	-0.9912	161	1.7188	1.1377	1.2061	0.625
12	0.0244	-0.1807	-10	-2.8662	62	-0.1904	-0.415	0.6689	-2.7197	112	-0.2051	0.3223	0.8936	0.0439	162	2.6855	1.0938	1.2109	0.7227
13	-0.1416	-0.2539	1.0645	-1.6357	63	-0.2246	-0.415	0.6494	-1.2109	113	-0.21	0.4883	0.9033	0.1367	163	3.4786	1.0156	1.2402	0.4883
14	-0.1758	-0.2979	1.04	-0.6445	64	-0.2246	-0.3906	-10	-4.9414	114	-0.1855	0.6641	0.9717	0.0098	164	3.8232	0.918	1.2695	0.8252
15	-0.1611	-0.3223	-4.8877	-2.0703	65	-0.2051	-0.3613	0.6738	-3.042	115	-0.1416	0.8105	1.0107	0.4004	165	3.6426	0.8057	-2.8809	-0.5225
16	-0.1318	-0.3369	0.9521	-1.1279	66	-0.21	-0.3369	0.6543	-1.5674	116	-0.0684	0.9473	-6.4209	-1.8213	166	2.9102	0.6738	1.2402	0.0684
17	-0.1611	-0.3516	0.9619	-0.4736	67	-0.2148	-0.3125	-10	-4.3848	117	0.1709	1.0498	1.084	-0.8203	167	1.8994	0.5322	1.2256	0.2881
18	-0.1611	-0.3711	-2.1729	-1.1963	68	-0.2002	-0.2637	0.6885	-2.749	118	0.5273	1.1182	1.1768	-0.1074	168	0.9326	0.3906	0.459	0.2295
19	-0.166	-0.3955	0.8691	-0.5811	69	-0.21	-0.1855	0.7129	-1.2988	119	0.6885	1.1475	0.127	-0.1416	169	0.1709	0.2441	1.167	0.3271
20	-0.1855	-0.4102	0.8496	-0.8643	70	-0.21	-0.0488	-5.083	-2.5879	120	1.1475	1.1523	1.1768	0.249	170	-0.1221	0.083	1.1572	0.4639
21	-0.2051	-0.4053	0.8203	0.0342	71	-0.2002	0.1318	0.7617	-1.4209	121	2.0215	1.1279	1.2061	0.4395	171	-0.0391	-0.0732	1.1182	0.4053
22	-0.21	-0.415	0.7959	0.0391	72	-0.2295	0.3076	0.7959	-0.7471	122	2.749	1.0986	1.2256	0.5908	172	-0.1563	-0.1855	1.0693	0.4492
23	-0.2051	-0.4102	0.8105	-0.3516	73	-0.2197	0.4736	-0.6348	-0.7861	123	3.0664	1.0254	1.2158	0.625	173	-0.127	-0.2588	1.0693	-0.0293
24	-0.2148	-0.3906	0.7813	0.1953	74	-0.2246	0.6348	0.8691	-0.3564	124	3.0811	0.9473	1.2451	0.3223	174	-0.1221	-0.3076	1.0156	0.4883
25	-0.2246	-0.3564	-10	-3.9748	75	-0.2002	0.7715	0.957	-0.5273	125	2.6221	0.8203	1.2451	0.7764	175	-0.1416	-0.332	-8.6816	-2.6221
26	-0.21	-0.3369	0.791	-2.5928	76	-0.1953	0.9033	0.9863	0.2539	126	1.8311	0.6934	1.2061	0.7764	176	-0.1465	-0.3516	0.9229	-1.5039
27	-0.2051	-0.3076	0.8008	-1.0938	77	-0.1221	1.0059	-9.5215	-2.8711	127	0.9326	0.5371	1.1963	0.415	177	-0.1807	-0.3613	0.8984	-0.6299
28	-0.21	-0.2637	-10	-4.8389	78	0.0439	1.0889	1.0596	-1.5576	128	0.1758	0.3955	1.2549	0.7764	178	-0.1904	-0.3906	-3.4033	-1.6016
29	-0.2197	-0.1807	0.8447	-2.8076	79	0.4297	1.1328	1.123	-0.4932	129	-0.1367	0.2344	-7.4805	-2.002	179	-0.1953	-0.4199	0.8203	-0.918
30	-0.2051	-0.0439	0.8643	-1.3818	80	0.6299	1.1523	-2.373	-1.1377	130	-0.0439	0.083	1.123	-0.918	180	-0.1953	-0.4248	0.8008	-0.4102
31	-0.2002	0.1318	-3.1006	-1.9385	81	0.918	1.1328	1.1621	-0.3418	131	-0.2002	-0.0928	1.0791	-0.3125	181	-0.21	-0.4346	-1.6504	-1.0107
32	-0.1953	0.2979	0.9033	-1.0498	82	1.9775	1.0986	1.2256	0.1074	132	-0.0879	-0.2002	-3.5791	-1.4404	182	-0.21	-0.4297	0.7471	-0.5078
33	-0.1758	0.4688	0.9668	-0.4102	83	2.7393	1.0352	-0.21	-0.0684	133	-0.1025	-0.2734	0.9863	-0.7373	183	-0.2002	-0.415	0.7422	-0.7764
34	-0.1611	0.625	0.9814	-0.1465	84	3.1787	0.9473	1.2305	0.2539	134	-0.0977	-0.3076	0.9766	-0.2686	184	-0.2051	-0.3857	0.7373	-0.0049
35	-0.1074	0.7813	1.0303	0.1563	85	3.2617	0.8301	1.25	0.4688	135	-0.1514	-0.3369	-0.1416	-0.4639	185	-0.2344	-0.3613	-9.4092	-3.1494
36	0.0293	0.9131	1.0791	-0.1611	86	2.8027	0.6982	1.25	0.5518	136	-0.166	-0.3516	0.8887	-0.1416	186	-0.2246	-0.3369	0.7324	-1.8018
37	0.3564	1.0303	1.1377	0.5664	87	1.9873	0.5469	1.2109	0.6006	137	-0.1855	-0.3662	0.8496	-0.5078	187	-0.2246	-0.3125	0.7373	-0.9277
38	0.6299	1.1133	-7.8516	-2.1924	88	1.0498	0.4053	1.2061	0.2441	138	-0.1953	-0.3857	0.8447	0.1807	188	-0.2197	-0.2637	-1.2695	-1.123
39	1.0205	1.1621	1.1816	-1.0156	89	0.2588	0.2539	1.1914	0.6836	139	-0.2051	-0.415	-10	-4.0967	189	-0.2002	-0.1855	0.7568	-0.6348
40	1.8652	1.167	1.2012	-0.21	90	-0.0391	0.1025	-9.9463	-2.7832	140	-0.2051	-0.4248	0.7715	-2.4512	190	-0.1953	-0.0488	0.7861	-0.9082
41	2.749	1.1426	-5.1904	-1.7383	91	-0.0049	-0.0635	1.1279	-1.4551	141	-0.2246	-0.4297	0.7373	-1.1768	191	-0.1807	0.1367	0.791	0.0244
42	3.3838	1.0938	1.2256	-0.708	92	-0.1318	-0.1758	1.1035	-0.5908	142	-0.2246	-0.4297	-5.8936	-2.7002	192	-0.1953	0.3174	-10	-4.0576
43	3.6377	1.0303	1.2744	-0.0293	93	-0.1025	-0.2539	-5.4785	-2.2314	143	-0.2246	-0.4248	0.6934	-1.6748	193	-0.1953	0.4883	0.8838	-2.3975
44	3.3643	0.9424	1.1084	0.1855	94	-0.127	-0.2979	1.0205	-1.1572	144	-0.2246	-0.3955	0.7031	-0.8057	194	-0.2002	0.6445	0.9326	-1.04
45	2.6514	0.835	1.2305	0.4395	95	-0.1172	-0.3271	0.9863	-0.5371	145	-0.21	-0.3662	-4.3994	-2.1045	195	-0.2051	0.7959	-5.5811	-2.5098
46	1.7236	0.708	1.2256	0.4932	96	-0.1318	-0.3418	-0.9521	-0.8301	146	-0.21	-0.3418	0.6982	-1.1963	196	-0.1807	0.9229	1.0107	-1.2207
47	0.7764	0.5664	1.2109	0.5908	97	-0.1416	-0.3613	0.8984	-0.4053	147	-0.21	-0.3174	0.6982	-0.6543	197	-0.0928	1.0254	1.0938	-0.4688
48	0.0977	0.4199	1.1523	0.5469	98	-0.166	-0.3809	0.8838	-0.7666	148	-0.2148	-0.2637	-1.4844	-1.0156	198	0.2344	1.0889	-0.2637	-0.4346
49	-0.0391	0.2637	1.1523	0.2539	99	-0.1904	-0.4053	0.8496	0.1025	149	-0.1807	-0.1807	0.7227	-0.5908	199	0.5371	1.1182	1.123	-0.0146
50	-0.0537	0.1025	1.1035	0.5762	100	-0.1953	-0.4199	-10	-4.0869	150	-0.1758	-0.0293	0.7715	-0.708	200	0.7178	1.1182	1.1572	-0.1855



Tinggi Gel 2 cm  
 Periode 1.2 dt

No	Load cell (Volt)	Seasim (Volt)	Trimmeter 1 (Volt)	Trimmeter 2 (Volt)	No	Load cell (Volt)	Seasim (Volt)	Trimmeter 1 (Volt)	Trimmeter 2 (Volt)	No	Load cell (Volt)	Seasim (Volt)	Trimmeter 1 (Volt)	Trimmeter 2 (Volt)	No	Load cell (Volt)	Seasim (Volt)	Trimmeter 1 (Volt)	Trimmeter 2 (Volt)
1	-0.2832	-0.0146	1.001	0.4346	51	-0.2783	-0.127	1.0205	-0.6982	101	-0.1709	-0.1953	1.0303	-1.1768	151	-0.083	-0.2295	1.0498	-0.0391
2	-0.2783	-0.0879	1.0205	0.4785	52	-0.249	-0.1709	1.1523	-0.2002	102	-0.1318	-0.2148	1.0449	-0.4834	152	0.0098	-0.2246	1.0693	0.4736
3	-0.2686	-0.1416	1.0156	0.3809	53	-0.1758	-0.1904	-1.9727	-0.8887	103	-0.0342	-0.2197	-7.1045	-2.6074	153	0.0781	-0.2197	1.0693	0.4346
4	-0.249	-0.1855	1.0156	0.4248	54	-0.127	-0.21	1.0352	-0.3809	104	0.0098	-0.2197	1.0498	-1.5283	154	0.0537	-0.2051	1.0742	-0.0195
5	-0.1611	-0.2051	1.0352	-0.1367	55	-0.0195	-0.2148	1.084	0	105	0.0684	-0.21	1.0742	-0.5713	155	-0.1563	-0.1709	1.0693	0.5127
6	-0.0977	-0.2197	1.0449	0.542	56	0.0391	-0.2148	-2.666	-1.0254	106	0.0391	-0.1953	-8.0908	-3.0566	156	-0.21	-0.1123	1.0645	0.4932
7	-0.0586	-0.2197	1.0352	0.4492	57	0.1123	-0.2051	1.0693	-0.4102	107	-0.1465	-0.1611	1.0742	-1.7188	157	-0.1953	-0.0342	1.0645	-0.0586
8	0.0049	-0.2197	1.0596	-0.1074	58	0.0293	-0.1855	1.0791	-0.0488	108	-0.2148	-0.1025	1.084	-0.7422	158	-0.2295	0.0635	1.0693	0.5908
9	0.0586	-0.21	1.0645	0.5566	59	-0.1855	-0.1416	-3.2666	-1.1816	109	-0.2051	-0.0244	-8.8965	-3.3203	159	-0.249	0.1367	1.0352	0.5127
10	0.0537	-0.1855	1.0596	0.5371	60	-0.2295	-0.0928	1.0596	-0.5566	110	-0.2295	0.0684	1.0645	-1.9824	160	-0.2295	0.21	1.0596	-0.0635
11	-0.166	-0.1465	1.0742	0.4736	61	-0.1758	0	1.084	-0.0488	111	-0.249	0.1416	1.0693	-0.7813	161	-0.2441	0.2588	1.0352	0.5957
12	-0.2051	-0.0879	1.0693	0.4932	62	-0.2197	0.083	-4.1064	-1.4893	112	-0.2393	0.21	-10	-4.0479	162	-0.2637	0.2979	1.0205	0.5566
13	-0.2002	0.0098	1.0547	0.4541	63	-0.2588	0.166	1.0645	-0.6982	113	-0.2393	0.2588	1.04	-2.3584	163	-0.2734	0.3125	1.0254	-0.0244
14	-0.2295	0.0977	1.0645	0.5029	64	-0.249	0.2295	1.0596	-0.1514	114	-0.249	0.293	1.0449	-1.0449	164	-0.2344	0.3076	1.0303	0.6152
15	-0.2441	0.1807	0.9521	0.4199	65	-0.2344	0.2881	-5.4297	-1.8799	115	-0.2588	0.3027	-9.4141	-3.6621	165	-0.2637	0.2686	-10	-3.5596
16	-0.2393	0.2441	1.0449	0.4736	66	-0.249	0.3125	1.0254	-1.0059	116	-0.2539	0.2881	1.0156	-2.0996	166	-0.2881	0.2246	1.0107	-1.9482
17	-0.2393	0.2979	1.0498	0.4688	67	-0.2783	0.3271	1.0352	-0.2637	117	-0.2734	0.2588	1.0205	-0.8789	167	-0.2881	0.1563	1.0107	-0.8447
18	-0.2344	0.3271	0.6201	0.3516	68	-0.2441	0.3027	-2.9541	-1.2744	118	-0.293	0.2051	-2.7637	-1.6064	168	-0.293	0.0879	-3.291	-1.6748
19	-0.2637	0.3418	1.0156	0.376	69	-0.2686	0.2734	1.0107	-0.5225	119	-0.2832	0.1367	0.9961	-0.7568	169	-0.2832	0	0.9961	-0.8496
20	-0.2295	0.3271	1.0205	-0.1318	70	-0.2832	0.21	0.9961	-0.1807	120	-0.2979	0.0635	1.0059	-0.3418	170	-0.2637	-0.0732	1.0303	-0.3174
21	-0.2734	0.3027	1.0303	0.5469	71	-0.2686	0.1465	1.0059	0.0635	121	-0.2783	-0.0195	1.0107	-0.0684	171	-0.2441	-0.1367	0.9717	-0.1172
22	-0.2832	0.2441	-10	-3.6035	72	-0.2832	0.0586	0.9814	0.1367	122	-0.2686	-0.0928	0.9961	0.0537	172	-0.2344	-0.166	1.0205	0.1025
23	-0.2881	0.1855	1.0059	-2.0264	73	-0.2979	-0.0146	1.0254	0.0049	123	-0.2588	-0.1465	1.0156	-0.1123	173	-0.2051	-0.1953	1.04	-0.415
24	-0.293	0.0977	1.0107	-0.8105	74	-0.2783	-0.0977	1.0156	0.3223	124	-0.2539	-0.1807	1.0303	0.293	174	-0.166	-0.2051	1.0449	0.415
25	-0.2832	0.0195	-3.1006	-1.6357	75	-0.2734	-0.1465	-5.8984	-1.7578	125	-0.1709	-0.2051	-9.4824	-2.9004	175	-0.0684	-0.2197	1.0303	0.3564
26	-0.2783	-0.0732	1.001	-0.791	76	-0.249	-0.1904	1.0107	-0.9375	126	-0.1123	-0.2148	1.0449	-1.7236	176	0.0146	-0.2148	1.0693	0.4199
27	-0.2734	-0.1367	1.0303	-0.3223	77	-0.21	-0.21	1.0498	-0.2588	127	-0.0488	-0.2246	1.0889	-0.6445	177	0.0879	-0.21	1.0449	0.3564
28	-0.2393	-0.1855	0.7178	-0.1611	78	-0.1563	-0.2246	-3.6572	-1.5137	128	-0.0049	-0.2197	-10	-3.833	178	0.0439	-0.1855	1.0645	0.4199
29	-0.2002	-0.2051	1.0254	0.0391	79	-0.0635	-0.2246	1.0449	-0.708	129	0.0732	-0.2148	1.0596	-2.2656	179	-0.1611	-0.1563	1.0791	0.3955
30	-0.1221	-0.2246	1.0449	0.1904	80	0	-0.2295	1.0547	-0.2246	130	0.0586	-0.1904	1.0791	-0.9814	180	-0.1953	-0.083	1.0107	0.4199
31	-0.0635	-0.2295	0.8496	0.1855	81	0.0684	-0.2197	-4.668	-1.7139	131	-0.1514	-0.1514	-10	-4.0967	181	-0.1904	0	1.0449	0.3809
32	0.0195	-0.2295	1.0498	0.2734	82	0.0537	-0.2002	1.0547	-0.9375	132	-0.2148	-0.0879	1.0742	-2.4854	182	-0.2441	0.0928	1.0742	0.4736
33	0.083	-0.2197	1.0742	0.3467	83	-0.127	-0.1611	1.0889	-0.2197	133	-0.1904	0	1.0742	-1.0498	183	-0.2734	0.1709	0.3711	0.1953
34	0.0684	-0.2051	0.4395	0.1709	84	-0.2051	-0.1074	-5.5176	-2.0459	134	-0.2344	0.0977	1.0547	-0.498	184	-0.249	0.2393	1.0498	0.3564
35	-0.1709	-0.166	1.0645	0.2783	85	-0.2246	-0.0195	1.0742	-1.0498	135	-0.2539	0.1758	1.0547	-0.5176	185	-0.2344	0.2832	1.04	0.3711
36	-0.2148	-0.1172	1.0645	0.3613	86	-0.2441	0.0732	1.0645	-0.4004	136	-0.2295	0.249	1.0645	0.1563	186	-0.249	0.3174	0.1904	0.1709
37	-0.1807	-0.0342	0.166	0.1123	87	-0.2197	0.1611	-6.9922	-2.5098	137	-0.2344	0.2979	1.0303	0.2637	187	-0.2637	0.3223	1.0059	0.2441
38	-0.21	0.0537	1.0498	0.249	88	-0.21	0.2246	1.0547	-1.4453	138	-0.249	0.3418	1.0449	-0.083	188	-0.249	0.3027	1.0303	-0.21
39	-0.2393	0.1367	1.0742	0.3711	89	-0.2295	0.2832	1.0645	-0.498	139	-0.249	0.3467	1.0352	0.4541	189	-0.2979	0.2686	1.0059	0.4688
40	-0.2246	0.2051	-0.6836	-0.1465	90	-0.2637	0.3223	-7.71	-2.8711	140	-0.2539	0.332	-10	-3.1982	190	-0.3076	0.21	-10	-3.6035
41	-0.2393	0.2686	1.0693	0.1367	91	-0.249	0.3418	1.0352	-1.5283	141	-0.2881	0.2881	1.0059	-1.7627	191	-0.2881	0.1367	1.001	-2.0654
42	-0.2393	0.2979	1.0352	0.2832	92	-0.2686	0.3271	1.0254	-0.6348	142	-0.2979	0.2393	1.0205	-0.6934	192	-0.2783	0.0586	1.0254	-0.8154
43	-0.2686	0.3174	-0.4688	-0.1172	93	-0.2686	0.3027	-2.8662	-1.3965	143	-0.2588	0.1611	-2.8418	-1.4746	193	-0.2979	-0.0293	-3.1689	-1.6992
44	-0.2344	0.3076	1.0059	0.1074	94	-0.2783	0.249	0.9912	-0.6934	144	-0.293	0.083	1.0059	-0.7031	194	-0.3076	-0.0977	1.0107	-0.7959
45	-0.2734	0.2783	1.0254	-0.3662	95	-0.293	0.1807	1.0205	-0.2002	145	-0.2881	-0.0098	1.0156	-0.2686	195	-0.2686	-0.1563	1.0156	-0.3711
46	-0.2832	0.2246	1.0107	0.4395	96	-0.2881	0.0977	1.001	-0.0488	146	-0.2881	-0.0879	1.0107	-0.488	196	-0.2246	-0.1855	0.6836	-0.1709
47	-0.2783	0.166	-1.7822	-0.5615	97	-0.2832	0.0146	1.001	0.1563	147	-0.2539	-0.1465	1.0059	0.0977	197	-0.1758	-0.21	1.0156	-0.0098
48	-0.2637	0.0879	1.001	-0.376	98	-0.2734	-0.0684	1.0059	-0.083	148	-0.2637	-0.1807	1.04	-0.1904	198	-0.1318	-0.2246	1.0547	0.2002
49	-0.2783	0.0098	1.0254	0.1318	99	-0.2539	-0.127	1.0352	0.3662	149	-0.1953	-0.21	1.0449	0.3467	199	-0.0488	-0.2295	0.8447	0.1465
50	-0.2783	-0.0732	-4.585	-1.5283	100	-0.2295	-0.1709	-7.2168	-2.2314	150	-0.1318	-0.2197	1.0352	0.3613	200	-0.0146	-0.2295	1.0498	0.293



No	Load cell (Volt)	Seasim (Volt)	Trimmer 1 (Volt)	Trimmer 2 (Volt)	No	Load cell (Volt)	Seasim (Volt)	Trimmer 1 (Volt)	Trimmer 2 (Volt)	No	Load cell (Volt)	Seasim (Volt)	Trimmer 1 (Volt)	Trimmer 2 (Volt)	No	Load cell (Volt)	Seasim (Volt)	Trimmer 1 (Volt)	Trimmer 2 (Volt)	No	Load cell (Volt)	Seasim (Volt)	Trimmer 1 (Volt)	Trimmer 2 (Volt)
1	-0.2197	0.1611	-2.749	-0.7031	51	-0.2246	0.2783	1.001	-0.6006	101	-0.2246	0.332	-10	-3.6475	151	-0.2246	0.3125	1.0059	-0.542					
2	-0.1855	0.0781	1.001	-0.249	52	-0.2197	0.2246	1.001	0.3125	102	-0.2393	0.3223	0.9912	-2.0898	152	-0.2441	0.3369	-1.001	-0.8594					
3	-0.1709	-0.0049	1.0303	0.0781	53	-0.21	0.1611	0.9912	0.293	103	-0.2246	0.2881	0.9961	-0.8936	153	-0.2295	0.3369	0.9863	-0.3076					
4	-0.1318	-0.0928	-0.874	-0.4199	54	-0.2148	0.0781	1.0205	0.0293	104	-0.2539	0.2344	-5.7373	-2.4658	154	-0.2393	0.3174	0.9863	-0.6982					
5	-0.0879	-0.1514	1.04	-0.0439	55	-0.1953	-0.0049	1.0303	0.4053	105	-0.2197	0.1611	1.001	-1.3037	155	-0.2197	0.2783	0.9961	0.2783					
6	-0.0293	-0.1953	1.1768	0.1758	56	-0.1318	-0.0879	1.0254	0.4443	106	-0.2246	0.0879	1.04	-0.542	156	-0.2393	0.2148	0.9766	0.2637					
7	0.0391	-0.2148	-3.208	-1.0303	57	-0.0342	-0.1514	1.04	-0.0537	107	-0.21	-0.0049	-2.7197	-1.3574	157	-0.2197	0.1465	1.0156	0.0244					
8	0.0928	-0.2344	1.0498	-0.5127	58	0.0146	-0.1953	1.1279	0.5566	108	-0.1514	-0.083	1.0254	-0.6592	158	-0.2197	0.0684	1.0156	0.3906					
9	0.1367	-0.2295	1.0742	0.0049	59	0.0781	-0.2197	1.04	0.4492	109	-0.083	-0.1514	1.0547	-0.1758	159	-0.166	-0.0098	-10	-3.0957					
10	0.0293	-0.2393	-7.3926	-2.4658	60	0.1123	-0.2295	1.0742	0.4932	110	-0.0146	-0.1904	-5.0879	-1.8652	160	-0.1318	-0.0928	1.0254	-1.8994					
11	-0.1416	-0.2246	1.0693	-1.4209	61	0.1221	-0.2344	0.752	0.3027	111	0.0977	-0.2197	1.0547	-1.04	161	-0.0684	-0.1465	1.0645	-0.6982					
12	-0.1709	-0.2197	1.0693	-0.5225	62	-0.0537	-0.2344	1.0645	0.4004	112	0.1416	-0.2295	1.0742	-0.3516	162	-0.0146	-0.1953	1.0303	-0.3223					
13	-0.1172	-0.1855	1.0498	-0.1416	63	-0.127	-0.2246	1.0645	0.3857	113	0.1367	-0.2393	-9.7461	-3.3838	163	0.0537	-0.2148	1.0645	-0.4883					
14	-0.1221	-0.1514	1.0742	-0.3955	64	-0.166	-0.21	-1.7725	-0.4443	114	-0.083	-0.2295	1.0693	-2.0752	164	0.1074	-0.2344	1.0547	0.2051					
15	-0.2002	-0.083	1.0498	0.3027	65	-0.166	-0.1807	1.0449	-0.1514	115	-0.1318	-0.2246	1.0742	-0.8105	165	0.1318	-0.2344	1.0596	0.3125					
16	-0.1514	0	1.0205	0.3174	66	-0.1904	-0.1318	1.0693	0.2002	116	-0.1465	-0.2051	1.0547	-0.3662	166	-0.0537	-0.2393	1.0596	0.3174					
17	-0.1904	0.0879	1.0303	-0.0879	67	-0.166	-0.0635	-5.4541	-1.7725	117	-0.1709	-0.1807	1.0693	-0.6152	167	-0.1318	-0.2197	0.3369	0.1514					
18	-0.1855	0.1563	1.0156	0.4688	68	-0.1709	0.0195	1.0352	-0.8887	118	-0.2295	-0.1318	1.0547	0.2148	168	-0.1514	-0.21	1.0547	0.2148					
19	-0.2051	0.2295	-10	-3.5352	69	-0.2002	0.0879	1.0254	-0.2588	119	-0.1953	-0.0781	1.0254	0.293	169	-0.1904	-0.1758	1.0986	0.3662					
20	-0.21	0.2783	0.9961	-2.0117	70	-0.21	0.1563	-4.1943	-1.5771	120	-0.1953	0	1.0352	0.3174	170	-0.21	-0.1416	-2.7832	-0.8496					
21	-0.2344	0.3174	1.001	-0.8496	71	-0.2246	0.2148	0.9961	-0.791	121	-0.21	0.0684	0.9961	0.3418	171	-0.1807	-0.0781	1.04	-0.3271					
22	-0.2148	0.332	-5.332	-2.3193	72	-0.2148	0.2637	1.0107	-0.2295	122	-0.2051	0.1416	1.0059	0.3369	172	-0.1758	-0.0098	1.0352	0.0146					
23	-0.2441	0.3369	0.9961	-1.2012	73	-0.2393	0.3076	-0.2441	-0.4297	123	-0.2246	0.2051	1.001	-0.0586	173	-0.2148	0.0732	-3.0957	-1.0938					
24	-0.2344	0.3223	0.9961	-0.5029	74	-0.2441	0.332	0.9863	-0.0488	124	-0.2246	0.2637	1.001	0.4541	174	-0.2246	0.1465	0.9961	-0.4883					
25	-0.2393	0.2881	-0.7471	-0.7178	75	-0.2393	0.332	0.9863	-0.4932	125	-0.2246	0.3027	-10	-3.1787	175	-0.2344	0.2148	1.0059	-0.083					
26	-0.2051	0.2295	0.9863	-0.2637	76	-0.2246	0.3223	1.001	0.3809	126	-0.2393	0.3271	1.0156	-1.8115	176	-0.2197	0.2686	0.2881	-0.1611					
27	-0.21	0.166	1.0107	-0.6104	77	-0.249	0.2783	0.9717	0.3369	127	-0.2344	0.3271	0.9961	-0.7324	177	-0.2197	0.3125	0.9766	0.0928					
28	-0.2051	0.083	1.0156	0.2832	78	-0.2197	0.2295	1.001	0.1367	128	-0.2441	0.3076	-4.9219	-2.1631	178	-0.2344	0.332	1.001	-0.3271					
29	-0.1758	0	1.0156	0.3076	79	-0.2002	0.1514	1.0107	0.4199	129	-0.249	0.2686	0.9766	-1.0645	179	-0.2393	0.3369	0.9961	0.4102					
30	-0.083	-0.0781	1.0352	-0.2539	80	-0.21	0.0732	-7.71	-2.2412	130	-0.249	0.21	0.9961	-0.4785	180	-0.2588	0.3125	-10	-3.6572					
31	-0.0342	-0.1416	1.04	0.4834	81	-0.1904	-0.0195	1.0156	-1.2793	131	-0.249	0.1416	-0.4785	-0.5859	181	-0.2393	0.2734	0.9912	-2.0898					
32	0.0195	-0.1855	1.1475	0.4932	82	-0.1172	-0.0928	1.0498	-0.4346	132	-0.2295	0.0635	0.9961	-0.2344	182	-0.2246	0.2148	1.001	-0.9082					
33	0.0635	-0.21	1.0596	0.4639	83	-0.0684	-0.1611	-8.6279	-3.1299	133	-0.2051	-0.0195	1.0254	0.0537	183	-0.2344	0.1465	-5.9277	-2.5293					
34	0.127	-0.2295	-0.7715	-0.1172	84	-0.0488	-0.1953	1.0645	-1.8408	134	-0.1367	-0.0928	0.9619	0.0977	184	-0.2002	0.0684	1.0107	-1.3818					
35	0.1465	-0.2344	1.0645	0.1025	85	0	-0.2246	1.0547	-0.752	135	-0.0781	-0.1514	1.0303	0.2441	185	-0.2051	-0.0049	1.04	-0.5615					
36	-0.0781	-0.2344	1.0938	0.293	86	0.1025	-0.2295	1.0498	-0.2783	136	0.0098	-0.1953	1.0449	0.2734	186	-0.1221	-0.083	-4.6484	-1.9727					
37	-0.1123	-0.2246	-3.6035	-1.1328	87	0.1221	-0.2393	1.0645	-0.5469	137	-0.1611	-0.2197	-0.4053	-0.1074	187	-0.0732	-0.1416	1.04	-1.0791					
38	-0.1123	-0.2148	1.0645	-0.5273	88	-0.0684	-0.2344	1.0791	0.2539	138	0.0732	-0.2295	1.0449	0.0635	188	-0.0635	-0.1855	1.0547	-0.415					
39	-0.1758	-0.1904	1.0742	-0.083	89	-0.127	-0.2344	1.0547	0.2734	139	0.1074	-0.2344	1.0791	0.2783	189	0.0195	-0.2148	-8.501	-3.042					
40	-0.1807	-0.1514	-7.9736	-2.8465	90	-0.1416	-0.2051	1.0742	0.3662	140	0.2295	-0.2295	-3.7061	-1.1963	190	0.1221	-0.2295	1.0596	-1.8457					
41	-0.1855	-0.083	1.0449	-1.5918	91	-0.166	-0.1855	0.1807	0.0684	141	-0.0098	-0.2197	1.0547	-0.5615	191	0.0928	-0.2344	1.0742	-0.7227					
42	-0.1709	-0.0049	1.0449	-0.5566	92	-0.1904	-0.1318	1.0498	0.2344	142	-0.166	-0.2051	1.0596	-0.1367	192	-0.0635	-0.2295	1.0498	-0.2979					
43	-0.1904	0.083	-9.8584	-3.5791	93	-0.1758	-0.0781	1.0449	0.3027	143	-0.166	-0.1758	-8.3301	-2.7734	193	-0.1611	-0.2197	1.0645	-0.5225					
44	-0.2197	0.1563	1.0059	-2.0117	94	-0.1758	0.0049	-1.8555	-0.5371	144	-0.1563	-0.127	1.04	-1.6992	194	-0.1904	-0.2051	1.0645	0.2295					
45	-0.2246	0.2148	1.0107	-0.918	95	-0.1953	0.0732	1.0107	-0.1563	145	-0.1904	-0.0732	1.0498	-0.6006	195	-0.1953	-0.1709	1.0498	0.2832					
46	-0.2246	0.2637	-5.083	-2.2607	96	-0.2246	0.1465	1.0156	0.1172	146	-0.1807	0.0049	-10	-3.8232	196	-0.1855	-0.1318	1.0596	0.3369					
47	-0.2344	0.2979	0.9912	-1.2012	97	-0.2148	0.2051	0.2881	-0.0293	147	-0.166	0.0879	1.0205	-2.168	197	-0.1758	-0.0732	0.2441	0.0928					
48	-0.2344	0.3174	1.001	-0.4736	98	-0.2197	0.2588	0.9912	0.166	148	-0.1953	0.1563	1.0107	-1.0156	198	-0.1611	0	1.0205	0.2197					
49	-0.2246	0.3223	-0.5273	-0.6689	99	-0.2148	0.2979	0.9912	-0.2734	149	-0.2148	0.2197	-5.4785	-2.4365	199	-0.2002	0.0781	1.0205	0.2979					
50	-0.2393	0.3076	0.9863	-0.2002	100	-0.2441	0.3271	0.9961	0.4346	150	-0.2295	0.2734	0.9814	-1.333	200	-0.2197	0.1465	0.9912	0.3174					



Tinggi Gel 2 cm  
 Periode 1.4 dt

No	Load cell (Volt)	Seasim (Volt)	Trimmeter 1 (Volt)	Trimmeter 2 (Volt)	No	Load cell (Volt)	Seasim (Volt)	Trimmeter 1 (Volt)	Trimmeter 2 (Volt)	No	Load cell (Volt)	Seasim (Volt)	Trimmeter 1 (Volt)	Trimmeter 2 (Volt)	No	Load cell (Volt)	Seasim (Volt)	Trimmeter 1 (Volt)	Trimmeter 2 (Volt)
1	-0.1367	-0.249	-1.6064	-0.332	51	0.1025	-0.166	-0.1904	0.0195	101	-0.2197	0.293	1.0303	0.3857	151	-0.2441	0.3223	-0.4004	-0.3809
2	-0.166	-0.2441	1.0596	-0.083	52	-0.1025	-0.2148	1.0889	0.1611	102	-0.1416	0.2246	1.0205	0.4346	152	-0.2441	0.3711	0.9863	-0.0146
3	-0.1807	-0.2246	1.0645	0.2539	53	-0.1611	-0.2246	1.1084	0.3369	103	-0.0537	0.1514	1.04	-0.1123	153	-0.2588	0.3906	0.9863	0.0146
4	-0.166	-0.2002	-7.6807	-2.417	54	-0.0488	-0.249	-0.6299	-0.2002	104	0.0537	0.0684	1.0596	0.5664	154	-0.2441	0.4053	1.001	0.293
5	-0.166	-0.1563	1.0303	-1.3623	55	-0.1465	-0.249	1.0986	0.1074	105	0.1416	-0.0195	1.0547	0.4834	155	-0.2295	0.3809	0.9863	0.2979
6	-0.1855	-0.0879	1.0596	-0.5029	56	-0.0928	-0.2588	1.1133	0.2588	106	0.2344	-0.0977	1.084	0.5225	156	-0.2148	0.3516	1.0303	-0.1367
7	-0.21	0.0049	-8.252	-2.9736	57	-0.1514	-0.249	-2.9102	-0.8887	107	0.1514	-0.1611	-0.8105	-0.1367	157	-0.2002	0.2881	1.0205	0.4834
8	-0.2295	0.0928	1.001	-1.7041	58	-0.1807	-0.249	1.0596	-0.4541	108	-0.0781	-0.2051	1.0889	0.1563	158	-0.1172	0.2295	1.0303	0.5029
9	-0.2197	0.1758	1.001	-0.6348	59	-0.1709	-0.2246	1.0742	-0.0049	109	-0.1514	-0.2344	1.2207	0.2979	159	-0.0391	0.1416	1.0498	0.4541
10	-0.249	0.249	-4.8828	-2.0996	60	-0.166	-0.2051	-9.4482	-3.1104	110	-0.0684	-0.2441	-1.8359	-0.5225	160	0.0488	0.0684	-0.5859	-0.0293
11	-0.2441	0.3076	0.9766	-1.0449	61	-0.1758	-0.1465	1.0352	-1.8555	111	-0.1318	-0.2539	1.0889	-0.1563	161	0.1953	-0.0195	1.0596	0.1367
12	-0.2441	0.3564	1.0205	-0.4248	62	-0.1709	-0.083	1.0254	-0.7422	112	-0.1025	-0.2539	1.0986	0.1709	162	0.2588	-0.0928	1.0986	0.3369
13	-0.2441	0.3857	-1.958	-0.9912	63	-0.1904	0.0146	-10	-3.8672	113	-0.1465	-0.249	-5.1904	-1.7041	163	0.0732	-0.166	-3.7793	-1.1621
14	-0.2539	0.3906	0.9961	-0.4492	64	-0.2148	0.0977	1.001	-2.2754	114	-0.1807	-0.2441	1.0645	-0.9375	164	-0.0977	-0.2051	1.1035	-0.4834
15	-0.2344	0.3809	1.0156	-0.0342	65	-0.2246	0.1855	1.001	-1.0107	115	-0.1514	-0.2246	1.0547	-0.293	165	-0.1465	-0.2344	1.1084	-0.0488
16	-0.2197	0.3467	-0.1465	-0.2734	66	-0.2344	0.2539	-6.8604	-2.9199	116	-0.166	-0.2002	-1.8555	-1.0205	166	-0.0586	-0.2393	-4.4092	-1.5283
17	-0.2002	0.3027	1.0156	0.0635	67	-0.2539	0.3223	0.9863	-1.5967	117	-0.1855	-0.1514	1.0352	-0.874	167	-0.1709	-0.2588	1.0889	-0.8008
18	-0.1318	0.2344	1.0352	0.1904	68	-0.2539	0.3613	0.9912	-0.6885	118	-0.21	-0.083	1.0303	-0.0098	168	-0.1025	-0.249	1.1035	-0.2051
19	-0.0293	0.1563	-2.6367	-0.8154	69	-0.2393	0.4004	-3.5449	-1.665	119	-0.21	0.0098	-10	-3.8037	169	-0.1465	-0.2539	-7.6807	-2.6855
20	0.0342	0.0684	1.0449	-0.4102	70	-0.2393	0.3955	0.9912	-0.8203	120	-0.2393	0.1025	1.001	-2.2168	170	-0.1807	-0.2393	1.0693	-1.6113
21	0.1563	-0.0244	1.0938	0.0586	71	-0.249	0.3857	1.0107	-0.2881	121	-0.2441	0.1904	0.9961	-0.9863	171	-0.1855	-0.2246	1.0547	-0.6104
22	0.2441	-0.1074	-8.0859	-2.6611	72	-0.2295	0.3516	-1.25	-0.7373	122	-0.2441	0.2637	-8.75	-3.418	172	-0.1807	-0.1953	1.0352	-0.2051
23	0.127	-0.1611	1.0938	-1.4941	73	-0.1953	0.3076	1.0205	-0.2441	123	-0.2539	0.3271	0.9766	-1.9971	173	-0.1758	-0.1465	1.0596	-0.5566
24	-0.083	-0.21	1.0986	-0.5762	74	-0.1367	0.2344	1.0742	0.0537	124	-0.249	0.3711	1.001	-0.8301	174	-0.1904	-0.0732	1.0254	0.2783
25	-0.1465	-0.2295	-10	-3.6035	75	-0.0586	0.1611	-3.8965	-1.3281	125	-0.2441	0.3906	-5.4297	-2.3877	175	-0.2148	0.0195	0.9912	0.2783
26	-0.0635	-0.2441	1.0938	-2.1729	76	0.0244	0.0684	1.0547	-0.7129	126	-0.2588	0.3906	0.9961	-1.2256	176	-0.2344	0.1123	1.0059	-0.0928
27	-0.1465	-0.249	1.1133	-0.8545	77	0.1709	-0.0244	1.084	-0.1416	127	-0.2539	0.3711	1.0156	-0.5371	177	-0.2637	0.1904	0.9912	0.4199
28	-0.083	-0.2539	1.0645	-0.415	78	0.2588	-0.1025	-9.7412	-3.252	128	-0.2344	0.3369	-2.6123	-1.2549	178	-0.2539	0.2637	-10	-3.7646
29	-0.1367	-0.249	1.0889	-0.498	79	0.0928	-0.1611	1.084	-1.9385	129	-0.2148	0.2832	1.0059	-0.6299	179	-0.249	0.3174	0.9814	-2.2266
30	-0.1758	-0.2441	1.0645	0.1563	80	-0.0977	-0.2051	1.1084	-0.752	130	-0.1221	0.2197	1.0498	-0.1123	180	-0.2441	0.3613	1.0791	-0.8936
31	-0.1709	-0.2246	1.0547	0.2832	81	-0.1563	-0.2295	-6.5186	-2.7637	131	-0.0635	0.1416	-4.9609	-1.8164	181	-0.2588	0.3857	-8.1641	-3.2275
32	-0.166	-0.2002	1.04	0.293	82	-0.0195	-0.249	1.1084	-1.709	132	0.0146	0.0684	1.0791	-0.9766	182	-0.2441	0.4004	0.9912	-1.7871
33	-0.1807	-0.1465	-0.5566	-0.1367	83	-0.1758	-0.2539	1.1084	-0.6104	133	0.1367	-0.0244	1.0645	-0.3271	183	-0.249	0.3809	1.001	-0.7568
34	-0.1904	-0.0781	1.0156	0.0391	84	-0.0977	-0.2588	1.0742	-0.2197	134	0.2295	-0.0977	-7.0996	-2.6318	184	-0.2393	0.3516	-4.7998	-2.0898
35	-0.1904	0.0244	1.0254	0.2441	85	-0.166	-0.2539	1.0693	-0.459	135	0.166	-0.1611	1.0645	-1.7578	185	-0.1709	0.2979	1.0205	-1.1328
36	-0.2295	0.1123	0.0977	-0.0439	86	-0.1709	-0.2441	1.0742	0.2539	136	-0.0732	-0.2051	1.1035	-0.5225	186	-0.1318	0.2295	1.0498	-0.376
37	-0.2246	0.1904	0.9863	0.1855	87	-0.166	-0.2295	1.0449	0.2881	137	-0.1367	-0.2393	1.0693	-0.2051	187	-0.0488	0.1514	-7.9839	-2.8564
38	-0.2295	0.2539	0.9814	-0.415	88	-0.1563	-0.2051	1.0449	0.3467	138	-0.0928	-0.249	1.1182	-0.415	188	0.0244	0.0732	1.0742	-1.7236
39	-0.2441	0.3125	0.9814	0.4785	89	-0.1855	-0.1563	-0.8398	-0.249	139	-0.1563	-0.2539	1.0791	0.2637	189	0.1172	-0.0098	1.0693	-0.6445
40	-0.2539	0.3564	0.9668	0.4004	90	-0.1758	-0.083	1.0156	0.0293	140	-0.1709	-0.2539	1.0791	0.3564	190	0.2197	-0.0879	1.0645	-0.2295
41	-0.2441	0.3906	1.001	0.0244	91	-0.1904	0.0098	1.0156	0.1807	141	-0.166	-0.2539	1.0645	0.3369	191	0.1465	-0.1514	1.084	-0.5371
42	-0.2295	0.3906	0.9961	0.4932	92	-0.2246	0.0977	-0.083	-0.083	142	-0.166	-0.2393	-0.4932	-0.0879	192	-0.083	-0.1953	1.0938	0.2881
43	-0.2295	0.3809	-10	-3.5889	93	-0.2441	0.1855	0.8643	0.0635	143	-0.166	-0.2246	1.0352	0.0586	193	-0.1514	-0.2295	1.084	0.3223
44	-0.2197	0.3418	1.001	-2.1484	94	-0.2539	0.2539	0.9863	-0.2783	144	-0.1953	-0.1953	1.0596	0.2783	194	-0.0537	-0.249	1.1182	0.3809
45	-0.1807	0.3027	1.04	-0.8154	95	-0.249	0.3174	0.9717	0.3662	145	-0.2051	-0.1465	-4.3164	-1.3867	195	-0.1367	-0.2539	1.0791	0.3711
46	-0.1074	0.2295	1.0156	-0.3711	96	-0.2441	0.3613	0.9717	0.4004	146	-0.1953	-0.0732	1.0205	-0.6348	196	-0.1172	-0.2539	1.0742	0.3857
47	-0.0732	0.1563	1.0547	-0.498	97	-0.2441	0.3906	0.9912	-0.0879	147	-0.2002	0.0244	1.0107	-0.1758	197	-0.1514	-0.2539	1.0742	0.4102
48	0.0146	0.0635	1.0498	0.2148	98	-0.2295	0.3906	1.001	0.5273	148	-0.2295	0.1172	-2.6807	-1.0645	198	-0.21	-0.2441	-2.124	-0.5859
49	0.1563	-0.0244	1.0596	0.332	99	-0.2246	0.3711	0.3076	0.0928	149	-0.2539	0.1953	0.9766	-0.5029	199	-0.1611	-0.2246	1.04	-0.2295
50	0.2539	-0.1172	1.0791	0.3516	100	-0.2344	0.3369	1.0107	-0.0586	150	-0.2441	0.2686	1.001	-0.0732	200	-0.1758	-0.1953	1.0498	0.127



Tinggi Gel 2 cm  
 Periode 1.5 dt

No	Load cell (Volt)	Seasim (Volt)	Trimmeter 1 (Volt)	Trimmeter 2 (Volt)	No	Load cell (Volt)	Seasim (Volt)	Trimmeter 1 (Volt)	Trimmeter 2 (Volt)	No	Load cell (Volt)	Seasim (Volt)	Trimmeter 1 (Volt)	Trimmeter 2 (Volt)	No	Load cell (Volt)	Seasim (Volt)	Trimmeter 1 (Volt)	Trimmeter 2 (Volt)	No	Load cell (Volt)	Seasim (Volt)	Trimmeter 1 (Volt)	Trimmeter 2 (Volt)
1	-0.1611	-0.2588	1.0303	0.4688	51	0.0342	0.0244	1.1133	0.376	101	-0.249	0.3662	-10	-3.5596	151	-0.1807	-0.2588	1.0498	0.0879					
2	-0.168	-0.2393	-8.2715	-2.3975	52	-0.0928	-0.0781	1.0938	0.3662	102	-0.2393	0.4004	1.001	-2.0801	152	-0.1709	-0.249	-7.334	-2.4219					
3	-0.1709	-0.2246	1.001	-1.3916	53	-0.0977	-0.1416	1.1182	0.4443	103	-0.2539	0.415	1.0059	-0.8496	153	-0.2002	-0.2197	1.0156	-1.3281					
4	-0.1953	-0.1807	1.0156	-0.5029	54	-0.0928	-0.1953	1.0986	0.3955	104	-0.2344	0.4248	-10	-4.0137	154	-0.2051	-0.1807	1.0059	-0.5371					
5	-0.2148	-0.127	-6.8652	-2.6221	55	-0.1318	-0.2246	1.0938	0.4443	105	-0.1563	0.4004	1.0205	-2.4512	155	-0.21	-0.1025	-5.9424	-2.3145					
6	-0.2197	-0.0439	0.9912	-1.4404	56	-0.083	-0.2441	1.0986	0.4297	106	-0.0684	0.3809	1.0449	-0.9912	156	-0.2344	-0.0195	0.9717	-1.3184					
7	-0.2197	0.0537	0.9961	-0.5713	57	-0.1123	-0.2539	-0.6299	-0.0879	107	0.0049	0.3223	1.04	-0.459	157	-0.2393	0.083	0.9814	-0.4834					
8	-0.2248	0.1465	-5.6299	-2.2314	58	-0.1123	-0.2637	1.0547	0.083	108	0.0684	0.2686	1.0645	-0.0732	158	-0.2393	0.1709	-6.2695	-2.4268					
9	-0.2295	0.2344	0.9766	-1.2256	59	-0.1416	-0.2588	1.0742	0.3027	109	0.1416	0.1855	-0.3418	-0.3467	159	-0.2441	0.2588	0.9717	-1.3525					
10	-0.2295	0.3174	1.0059	-0.4346	60	-0.166	-0.2686	-8.0273	-2.4756	110	0.2295	0.1123	1.0742	0	160	-0.2539	0.3125	0.9766	-0.5127					
11	-0.21	0.3662	-3.7842	-1.6064	61	-0.1807	-0.2588	1.04	-1.5137	111	0.1855	0.0195	1.0938	0.1953	161	-0.2637	0.3613	-6.4746	-2.4561					
12	-0.2148	0.4199	1.0107	-0.7715	62	-0.1709	-0.249	1.0498	-0.5273	112	-0.0684	-0.0684	-4.668	-1.4746	162	-0.2539	0.3906	0.9814	-1.3623					
13	-0.1904	0.4346	1.0254	-0.2148	63	-0.2051	-0.2246	-7.5488	-2.9443	113	-0.0977	-0.1465	1.0938	-0.7861	163	-0.2441	0.415	1.0107	-0.498					
14	-0.1318	0.4443	-5.2246	-1.8799	64	-0.1953	-0.1855	1.001	-1.8555	114	-0.0928	-0.1953	1.1084	-0.1855	164	-0.21	0.4102	-4.5654	-1.8848					
15	-0.1025	0.4297	1.04	-1.0645	65	-0.1953	-0.127	0.9961	-0.7178	115	-0.1465	-0.2295	-10	-3.3984	165	-0.1904	0.4004	1.0156	-0.9863					
16	-0.0635	0.3955	1.0645	-0.293	66	-0.2197	-0.0391	-10	-3.9697	116	-0.1807	-0.249	1.0742	-2.1387	166	-0.1367	0.3613	1.04	-0.293					
17	0.0635	0.3467	1.0547	0.0098	67	-0.2295	0.0586	0.9863	-2.3633	117	-0.1318	-0.2637	1.0693	-0.8057	167	-0.1025	0.3174	-8.2373	-2.8564					
18	0.2002	0.2832	1.0889	-0.3467	68	-0.2344	0.1563	0.9863	-1.0498	118	-0.1416	-0.2686	1.0498	-0.3516	168	-0.0391	0.2588	1.0498	-1.7676					
19	0.332	0.2051	1.0986	0.4297	69	-0.2344	0.2441	-9.6631	-3.7939	119	-0.1465	-0.2686	1.084	-0.0488	169	0.0537	0.1807	1.0645	-0.6201					
20	0.1416	0.1172	1.0938	0.4395	70	-0.249	0.3174	0.9814	-2.2021	120	-0.1758	-0.2637	-1.7041	-0.7666	170	0.1904	1.0205	1.0596	-0.21					
21	-0.0635	0.0244	1.1279	0.4785	71	-0.2344	0.376	0.9961	-1.0059	121	-0.1709	-0.2588	1.0156	-0.3174	171	0.21	0.0098	1.0742	0.0391					
22	-0.0928	-0.0684	1.1279	0.459	72	-0.21	0.4102	-7.627	-3.0957	122	-0.1758	-0.2441	1.0303	-0.0146	172	0.1025	-0.0781	-0.3125	-0.2441					
23	0.0488	-0.1416	1.1133	0.4883	73	-0.2197	0.4346	1.0107	-1.7773	123	-0.1855	-0.2246	-3.0811	-1.1426	173	-0.1221	-0.1465	1.0645	0.0049					
24	-0.1367	-0.1904	1.1426	-0.083	74	-0.1904	0.4346	1.0303	-0.7471	124	-0.21	-0.1758	1.001	-0.5469	174	-0.166	-0.2002	1.084	0.2246					
25	0.0146	-0.2246	1.1182	0.6152	75	-0.1221	0.4199	-8.96	-3.3936	125	-0.21	-0.1221	0.9961	-0.1367	175	-0.1025	-0.2295	-6.6309	-2.1045					
26	-0.1172	-0.2441	1.0938	0.5176	76	-0.0488	0.3809	1.04	-2.0703	126	-0.21	-0.0244	-1.8848	-0.8838	176	-0.1367	-0.2539	1.0596	-1.2695					
27	-0.1221	-0.2588	1.1035	0.5371	77	0.0586	0.3369	1.0547	-0.8057	127	-0.2197	0.0732	0.9766	-0.3369	177	-0.2051	-0.2637	1.0596	-0.4199					
28	-0.1221	-0.2637	0.9277	0.3955	78	0.1367	0.2686	1.0547	-0.2881	128	-0.2441	0.1709	0.9814	-0.0635	178	-0.1611	-0.2734	1.0303	-0.0879					
29	-0.166	-0.2637	1.0645	0.4443	79	0.2734	0.1953	1.0889	-0.0293	129	-0.2441	0.2588	-1.2305	-0.5615	179	-0.166	-0.2734	1.04	-0.2637					
30	-0.1465	-0.2588	1.084	0.4346	80	0.2637	0.1074	0.498	-0.0049	130	-0.2441	0.3223	0.9766	-0.1953	180	-0.1758	-0.2686	0.9717	0.2393					
31	-0.1563	-0.2539	-4.917	-1.3867	81	0.0488	0.0244	1.0889	0.1416	131	-0.2393	0.3711	1.001	0.1025	181	-0.2246	-0.2588	1.001	0.2344					
32	-0.1807	-0.2441	1.0303	-0.8105	82	-0.0684	-0.0684	1.1182	0.3271	132	-0.249	0.4004	0.0977	-0.1074	182	-0.2051	-0.2441	1.0107	-0.0146					
33	-0.1807	-0.2197	1.0352	-0.1611	83	-0.0635	-0.1416	0.083	0.0098	133	-0.2197	0.415	1.0059	0.1563	183	-0.2246	-0.2246	0.9766	0.3369					
34	-0.1904	-0.1855	-8.2617	-2.8564	84	-0.0928	-0.1904	1.1035	0.2344	134	-0.1758	0.4199	1.0205	0.249	184	-0.2246	-0.1758	1.0059	0.3809					
35	-0.21	-0.1221	1.001	-1.5869	85	-0.1172	-0.2197	1.1084	0.293	135	-0.1221	0.4004	-1.3037	-0.3613	185	-0.2344	-0.1074	0.9766	-0.2832					
36	-0.2197	-0.0439	0.9961	-0.7129	86	-0.1025	-0.249	-1.4746	-0.415	136	-0.0586	0.3711	1.04	-0.0928	186	-0.2344	-0.0146	0.9668	0.4932					
37	-0.2197	0.0586	-6.4844	-2.5586	87	-0.1318	-0.2637	1.084	-0.1367	137	0.0244	0.3174	1.0645	0.2686	187	-0.2393	0.083	0.9619	0.3857					
38	-0.2344	0.1514	0.9717	-1.4795	88	-0.1074	-0.2637	1.084	0.21	138	0.1221	0.2539	-8.1201	-2.5195	188	-0.2344	0.1758	0.9766	-0.2002					
39	-0.2393	0.2393	0.9961	-0.5273	89	-0.1465	-0.2686	-8.3936	-2.6758	139	0.249	0.1807	1.0938	-1.4502	189	-0.2539	0.2588	0.8643	0.459					
40	-0.2393	0.3125	-5.2441	-2.1533	90	-0.1709	-0.2637	0.9326	-1.6797	140	0.2246	0.0977	1.0986	-0.4932	190	-0.2441	0.3174	0.9717	0.4785					
41	-0.2295	0.3711	0.9961	-1.0889	91	-0.1807	-0.2637	1.0254	-0.6201	141	-0.0049	0.0146	1.0938	-0.0781	191	-0.2441	0.3613	0.9766	-0.2246					
42	-0.2393	0.4102	1.001	-0.4395	92	-0.1855	-0.249	1.0205	-0.1953	142	-0.0781	-0.0781	1.1035	-0.3076	192	-0.249	0.3857	0.9912	0.5908					
43	-0.2295	0.4346	-3.5107	-1.46	93	-0.2051	-0.2295	1.0059	-0.5273	143	-0.0586	-0.1465	1.123	0.3564	193	-0.2441	0.4053	0.9814	0.4785					
44	-0.1855	0.4395	1.0059	-0.7568	94	-0.2002	-0.1807	1.0791	0.2783	144	-0.1025	-0.2002	1.0791	0.3369	194	-0.2246	0.4004	1.0254	-0.0342					
45	-0.1465	0.4248	1.0498	-0.1416	95	-0.2148	-0.1172	0.9668	0.2441	145	-0.1318	-0.2295	1.1084	-0.0879	195	-0.21	0.3857	1.0107	0.5664					
46	-0.1172	0.3955	-7.3975	-2.5537	96	-0.2051	-0.0293	0.9961	-0.0928	146	-0.1367	-0.2539	1.084	0.4785	196	-0.1416	0.3613	1.0303	0.5713					
47	0	0.3467	1.0596	-1.499	97	-0.2344	0.0732	0.9766	0.376	147	-0.1611	-0.2637	1.0742	0.4932	197	-0.083	0.3125	1.04	0.5029					
48	0.127	0.2783	1.0693	-0.5127	98	-0.2295	0.166	0.9717	0.4199	148	-0.1318	-0.2637	1.0645	0.4297	198	-0.0244	0.2588	-1.5967	-0.293					
49	0.2393	0.2051	1.0791	-0.0928	99	-0.2441	0.249	0.9668	-0.0391	149	-0.1563	-0.2686	-2.6123	-0.6836	199	0.0781	0.1807	1.0498	-0.0635					
50	0.293	0.1074	1.1279	-0.4102	100	-0.2539	0.3174	0.9912	0.5029	150	-0.1758	-0.2686	1.0303	-0.3564	200	0.2002	0.1025	1.0889	0.293					



No	Load cell (Volt)	Seasim (Volt)	Trimmer 1 (Volt)	Trimmer 2 (Volt)	No	Load cell (Volt)	Seasim (Volt)	Trimmer 1 (Volt)	Trimmer 2 (Volt)	No	Load cell (Volt)	Seasim (Volt)	Trimmer 1 (Volt)	Trimmer 2 (Volt)	No	Load cell (Volt)	Seasim (Volt)	Trimmer 1 (Volt)	Trimmer 2 (Volt)
1	0.0293	0.0781	1.1279	0.5322	51	-0.2539	0.1025	0.9668	-0.0928	101	-0.1172	-0.21	1.0156	0.4004	151	-0.2295	0.4004	1.0107	0.498
2	-0.1172	-0.0244	1.123	0.5371	52	-0.2588	0.1758	-8.2686	-2.7832	102	-0.1318	-0.2441	1.0449	0.3613	152	-0.2148	0.4346	1.001	0.4297
3	0	-0.1074	1.1084	0.498	53	-0.2637	0.2637	0.9717	-1.6455	103	-0.1807	-0.2539	1.0645	0.4346	153	-0.1807	0.4639	1.0449	0.5029
4	-0.1123	-0.1709	1.1084	0.5273	54	-0.2539	0.3271	0.9863	-0.6445	104	-0.1709	-0.2686	-6.1621	-1.8457	154	-0.1465	0.4888	-0.5762	-0.0635
5	-0.1172	-0.21	0.0928	0.1611	55	-0.2295	0.3906	-9.4189	-3.4424	105	-0.166	-0.2686	1.0254	-1.0498	155	-0.0439	0.4639	1.0547	0.1855
6	-0.1074	-0.2393	1.0742	0.3027	56	-0.2246	0.4346	1.0059	-2.0264	106	-0.1904	-0.2734	1.0107	-0.3613	156	0.1025	0.4346	1.0596	0.3467
7	-0.1465	-0.2539	1.0889	0.3809	57	-0.2295	0.4688	1.0303	-0.835	107	-0.2051	-0.2637	-9.3213	-3.2422	157	0.166	0.3809	-9.4141	-2.7734
8	-0.1416	-0.2637	-7.9688	-2.3682	58	-0.1709	0.4736	1.0059	-0.3467	108	-0.2051	-0.2686	0.9863	-1.9727	158	0.2246	0.3125	1.0693	-1.792
9	-0.1514	-0.2637	1.0449	-1.5381	59	-0.0928	0.4736	1.04	-0.6152	109	-0.2148	-0.249	1.0107	-0.8252	159	0.2393	0.2393	1.0986	-0.498
10	-0.1465	-0.2686	1.0254	-0.459	60	0	0.4443	0.8203	0.21	110	-0.2197	-0.2393	-10	-4.2871	160	-0.0049	0.1611	1.0645	-0.1709
11	-0.1611	-0.2637	1.0107	-0.166	61	0.1025	0.4053	1.0547	0.3223	111	-0.2295	-0.2002	0.9668	-2.6758	161	-0.1123	0.0684	1.1084	0.1367
12	-0.1563	-0.2637	1.001	-0.4688	62	0.2197	0.3369	1.0742	0.4102	112	-0.2441	-0.1514	0.9521	-1.2061	162	-0.127	-0.0244	-0.7568	-0.3662
13	-0.1904	-0.249	0.9863	0.2441	63	0.2588	0.2637	-6.3721	-1.8457	113	-0.2441	-0.0684	0.9521	-0.5957	163	-0.1709	-0.1172	1.0547	-0.0391
14	-0.2197	-0.2393	0.9619	0.2832	64	0.0879	0.166	1.0791	-1.0889	114	-0.2588	0.0146	0.9619	-0.2783	164	-0.1709	-0.1758	1.0742	0.166
15	-0.2393	-0.2002	0.9668	-0.2393	65	-0.0928	0.0781	1.0986	-0.2588	115	-0.2539	0.1074	0.2588	-0.249	165	-0.1367	-0.2148	-9.4873	-2.9443
16	-0.2344	-0.1611	0.2588	0.2002	66	-0.1563	-0.0293	1.0693	0	116	-0.2588	0.1855	0.957	-0.0537	166	-0.1367	-0.2441	1.1572	-1.9531
17	-0.249	-0.083	0.9473	0.2393	67	-0.0342	-0.1123	1.0889	0.1807	117	-0.2588	0.2686	0.9912	0.1709	167	-0.1758	-0.2588	1.0498	-0.6152
18	-0.2588	0.0098	0.957	0.3271	68	-0.127	-0.1807	0.3613	0.0244	118	-0.2441	0.3271	-0.2832	-0.1953	168	-0.1758	-0.2686	1.0107	-0.293
19	-0.2539	0.1074	-4.1309	-1.2598	69	-0.127	-0.2148	1.0693	0.1807	119	-0.21	0.3955	1.0059	0.1025	169	-0.1758	-0.2686	1.0303	0.0146
20	-0.2686	0.1904	0.9521	-0.6592	70	-0.1416	-0.249	1.0645	0.2979	120	-0.2002	0.4346	1.0107	0.2148	170	-0.1953	-0.2734	-0.542	-0.4102
21	-0.249	0.2686	0.9863	-0.0879	71	-0.1855	-0.2539	-8.5352	-2.6074	121	-0.2002	0.4736	-1.5283	-0.4492	171	-0.1904	-0.2686	1.001	-0.0635
22	-0.2441	0.332	-7.2656	-2.4365	72	-0.1563	-0.2686	1.0303	-1.6748	122	-0.1465	0.4736	1.0205	-0.1514	172	-0.21	-0.2637	0.9863	0.0586
23	-0.2393	0.3906	0.9961	-1.3672	73	-0.1709	-0.2686	1.04	-0.5615	123	-0.1221	0.4736	1.0498	0.2393	173	-0.2295	-0.249	-1.2744	-0.5176
24	-0.2148	0.4297	1.0107	-0.5029	74	-0.2002	-0.2734	1.001	-0.2344	124	0.0342	0.4346	-9.9219	-3.0859	174	-0.2246	-0.2344	0.9473	-0.2393
25	-0.2148	0.459	-7.9736	-2.9102	75	-0.1855	-0.2686	1.0107	-0.4834	125	0.1611	0.3906	1.0693	-1.9385	175	-0.2393	-0.1953	0.9863	0.0732
26	-0.1611	0.4639	1.0205	-1.709	76	-0.1807	-0.2686	0.9863	0.1953	126	0.2344	0.3174	1.0693	-0.6396	176	-0.2441	-0.1416	-5.1221	-1.7773
27	-0.1221	0.459	1.0449	-0.6348	77	-0.21	-0.2539	0.9717	0.249	127	0.2246	0.2393	1.0742	-0.166	177	-0.2686	-0.0586	0.9619	-1.0059
28	-0.0391	0.4346	1.0254	-0.2051	78	-0.2441	-0.2441	0.9668	-0.3418	128	0.0781	1.1465	1.0791	0.0537	178	-0.2588	0.0391	0.957	-0.376
29	0.0391	0.3955	1.0596	0.0586	79	-0.2441	-0.2051	0.9277	0.3955	129	-0.127	0.0635	-2.71	-0.9277	179	-0.2734	0.127	-10	-3.75
30	0.0928	0.332	-0.8594	-0.3809	80	-0.2393	-0.166	0.9619	0.3418	130	-0.1758	-0.0391	1.0693	-0.498	180	-0.2734	0.2051	0.957	-2.3535
31	0.1709	0.2637	1.0645	-0.0879	81	-0.2539	-0.083	0.9668	0.3711	131	-0.0684	-0.1123	1.1035	0	181	-0.2441	0.2783	0.9912	-0.9424
32	0.1855	0.1709	1.0742	0.2051	82	-0.249	0.0049	-1.7285	-0.5078	132	-0.1465	-0.1758	-0.332	-0.4688	182	-0.2295	0.3467	-10	-4.5605
33	0.1221	0.083	-10	-3.1982	83	-0.2539	0.1025	0.9619	-0.1367	133	-0.1416	-0.21	1.0742	-0.6396	183	-0.2246	0.4004	1.0254	-2.71
34	0.0146	-0.0195	1.0693	-2.0703	84	-0.2588	0.1807	0.9961	0.1074	134	-0.1563	-0.2441	0.8301	0.1221	184	-0.2197	0.4395	1.0156	-1.2305
35	-0.1465	-0.1074	1.0645	-0.7031	85	-0.2539	0.2637	-3.3154	-1.1035	135	-0.1904	-0.2539	1.04	0.2637	185	-0.1807	0.4688	1.0107	-0.542
36	-0.1807	-0.1709	1.0449	-0.2783	86	-0.2393	0.3271	0.9814	-0.5078	136	-0.1758	-0.2686	1.0449	0.293	186	-0.1367	0.4736	1.0156	-0.7959
37	-0.1221	-0.2148	1.0791	0.0098	87	-0.2393	0.3955	1.0303	-0.0391	137	-0.1904	-0.2686	-4.1064	-1.2354	187	-0.083	0.459	0.9424	0.1758
38	-0.1465	-0.2393	-5.3271	-1.8213	88	-0.2344	0.4395	-3.916	-1.4014	138	-0.1855	-0.2783	1.0156	-0.6787	188	-0.0049	0.4346	1.04	0.2344
39	-0.1904	-0.2539	1.0352	-1.0938	89	-0.1904	0.4736	1.0303	-0.6934	139	-0.1758	-0.2686	1.0156	-0.1123	189	0.1074	0.3857	1.0693	0.4053
40	-0.166	-0.2686	1.0449	-0.3467	90	-0.1172	0.4785	1.0352	-0.1514	140	-0.1953	-0.2686	-5.0635	-1.8701	190	0.1807	0.3271	-6.4844	-1.9385
41	-0.166	-0.2686	-10	-3.916	91	-0.0635	0.4736	-7.2217	-2.5488	141	-0.2148	-0.2539	0.9814	-1.001	191	0.2002	0.2539	1.0791	-1.1279
42	-0.1611	-0.2734	1.001	-2.3877	92	0.0342	0.4395	1.0547	-1.8164	142	-0.2148	-0.2393	0.9717	-0.376	192	0.166	0.166	1.0742	-0.3174
43	-0.1953	-0.2686	0.9961	-1.0547	93	0.1318	0.4004	0.9961	-0.4297	143	-0.2393	-0.1953	-8.4229	-2.9688	193	-0.0195	0.0732	1.0693	0.0195
44	-0.2148	-0.2637	-10	-4.6191	94	0.2295	0.332	1.0547	-0.1025	144	-0.2344	-0.1465	0.9473	-1.8848	194	-0.1318	-0.0293	1.0693	0.1416
45	-0.2393	-0.2539	0.9668	-2.9541	95	0.2637	0.2539	1.1035	0.1855	145	-0.2441	-0.0684	0.9619	-0.7373	195	-0.1611	-0.1172	-1.2939	-0.459
46	-0.2197	-0.2393	0.9521	-1.3037	96	0.0293	0.1563	-4.3604	-1.4209	146	-0.2637	0.0244	0.9375	-0.376	196	-0.1709	-0.1807	1.0547	-0.2246
47	-0.2441	-0.2051	0.9375	-0.6982	97	-0.1025	0.0684	1.1963	-0.7031	147	-0.2539	0.1172	0.9766	-0.5664	197	-0.1904	-0.2148	1.0645	0.1318
48	-0.2344	-0.1611	0.9473	-0.3174	98	-0.1563	-0.0391	1.0889	-0.1465	148	-0.2588	0.1953	0.9668	0.1563	198	-0.1514	-0.2441	-10	-3.7695
49	-0.249	-0.0879	-2.0996	-1.0449	99	-0.1514	-0.1123	1.0693	0.1025	149	-0.2441	0.2783	0.9863	0.2881	199	-0.1465	-0.2637	1.0352	-2.3682
50	-0.249	0.0098	0.9375	-0.5664	100	-0.1709	-0.1807	1.0693	-0.3613	150	-0.2295	0.3418	0.9912	-0.2588	200	-0.21	-0.2686	1.0205	-0.9688



No	Load cell (Volt)	Seasim (Volt)	Trimmetter 1 (Volt)	Trimmetter 2 (Volt)	No	Load cell (Volt)	Seasim (Volt)	Trimmetter 1 (Volt)	Trimmetter 2 (Volt)	No	Load cell (Volt)	Seasim (Volt)	Trimmetter 1 (Volt)	Trimmetter 2 (Volt)	No	Load cell (Volt)	Seasim (Volt)	Trimmetter 1 (Volt)	Trimmetter 2 (Volt)	No	Load cell (Volt)	Seasim (Volt)	Trimmetter 1 (Volt)	Trimmetter 2 (Volt)
1	-0.2051	-0.2686	0.874	0.4297	51	-0.0586	0.4736	1.0547	0.2783	101	-0.2002	-0.2588	1.0156	-0.2734	151	-0.2393	0.3809	1.0352	1.0352	101	-0.2002	-0.2588	1.0156	-0.2734
2	-0.2295	-0.2637	1.001	-0.0244	52	0.0293	0.498	-0.5908	-0.1465	102	-0.2002	-0.2637	1.0156	-0.0537	152	-0.1953	0.4199	-10	-3.6621	102	-0.2002	-0.2637	1.0156	-0.0537
3	-0.2344	-0.2686	0.9814	0.4541	53	0.1709	0.498	1.0693	0.083	103	-0.2148	-0.2686	-2.0117	-0.8203	153	-0.1514	0.459	1.0498	-2.3682	103	-0.2148	-0.2686	-2.0117	-0.8203
4	-0.2441	-0.2588	0.9717	0.4395	54	0.2832	0.4883	1.1035	0.3467	104	-0.2148	-0.2734	0.9814	-0.4102	154	-0.0439	0.4736	0.8398	-0.8887	104	-0.2148	-0.2734	0.9814	-0.4102
5	-0.2588	-0.2588	0.9619	0.3662	55	0.2246	0.459	-8.3789	-2.4951	105	-0.2344	-0.2734	1.0059	-0.0195	155	0.0342	0.4834	1.0596	-0.3174	105	-0.2344	-0.2734	1.0059	-0.0195
6	-0.2637	-0.2344	-0.6299	-0.1221	56	-0.0586	0.4053	1.1084	-1.4551	106	-0.249	-0.2686	-5.7373	-2.0117	156	0.1465	0.4688	1.1133	0.0146	106	-0.249	-0.2686	-5.7373	-2.0117
7	-0.2734	-0.2197	0.9521	0.0195	57	-0.1221	0.3369	1.123	-0.4248	107	-0.2539	-0.2588	0.957	-1.1865	157	0.1904	0.4443	-8.1396	-2.5928	107	-0.2539	-0.2588	0.957	-1.1865
8	-0.2783	-0.1709	0.9863	0.2393	58	-0.0684	0.2588	1.0986	-0.0586	108	-0.2637	-0.2441	0.9717	-0.4688	158	0.1611	0.3955	1.084	-1.6455	108	-0.2637	-0.2441	0.9717	-0.4688
9	-0.2637	-0.1123	-5.2832	-1.6992	59	-0.1416	0.1709	1.1182	-0.4102	109	-0.2783	-0.2148	-6.2842	-2.4951	159	0.0195	0.3418	1.1035	-0.4639	109	-0.2783	-0.2148	-6.2842	-2.4951
10	-0.2637	-0.0098	0.9766	-0.9082	60	-0.1416	0.0879	1.0938	0.4004	110	-0.2783	-0.166	0.9619	-1.8408	160	-0.1514	0.2588	1.0742	-0.1367	110	-0.2783	-0.166	0.9619	-1.8408
11	-0.2783	0.0781	0.9863	-0.3076	61	-0.166	0	1.0938	0.4199	111	-0.2783	-0.0928	0.9619	-0.5273	161	-0.2051	0.1807	1.0986	0.1465	111	-0.2783	-0.0928	0.9619	-0.5273
12	-0.2686	0.1807	-8.4814	-2.915	62	-0.21	-0.083	1.0986	0.4639	112	-0.2637	0	0.9619	-0.2441	162	-0.1465	0.0879	-1.8994	-0.7031	112	-0.2637	0	0.9619	-0.2441
13	-0.249	0.2588	1.1084	-1.7285	63	-0.1465	-0.1514	-5.9424	-1.7139	113	-0.2686	0.0879	0.9961	0.0391	163	-0.1855	0	1.0742	-0.3223	113	-0.2686	0.0879	0.9961	0.0391
14	-0.2197	0.3369	1.0254	-0.6201	64	-0.1416	-0.1953	1.0645	-1.1279	114	-0.2637	0.1807	0.4102	-0.0684	164	-0.1367	-0.0928	1.0742	0.0439	114	-0.2637	0.1807	0.4102	-0.0684
15	-0.1709	0.3906	1.0059	-0.2393	65	-0.2002	-0.2295	1.0547	-0.2441	115	-0.2393	0.2588	1.0059	0.166	165	-0.1611	-0.1465	1.0498	0.21	115	-0.2393	0.2588	1.0059	0.166
16	-0.1563	0.4443	1.0352	0.0732	66	-0.2148	-0.2441	1.0303	-0.0098	116	-0.2246	0.332	1.0156	0.249	166	-0.2148	-0.1953	1.0547	0.2539	116	-0.2246	0.332	1.0156	0.249
17	-0.0977	0.4736	-0.6885	-0.3467	67	-0.2002	-0.2539	1.0352	0.1611	117	-0.2148	0.3906	-3.208	-0.9473	167	-0.1904	-0.2246	-1.3477	-0.4199	117	-0.2148	0.3906	-3.208	-0.9473
18	0.0049	0.4932	1.0596	-0.0391	68	-0.2002	-0.2637	-2.6465	-0.918	118	-0.1514	0.4395	1.0303	-0.5469	168	-0.2051	-0.249	1.0156	-0.1807	118	-0.1514	0.4395	1.0303	-0.5469
19	0.1416	0.4932	1.0889	0.2197	69	-0.2197	-0.2686	1.001	-0.4297	119	-0.0781	0.4736	1.0645	0.0439	169	-0.2051	-0.2588	1.0254	0.1563	119	-0.0781	0.4736	1.0645	0.0439
20	0.2588	0.4785	-3.1641	-1.0742	70	-0.2344	-0.2734	1.001	-0.0537	120	0.0098	0.4932	1.04	0.1758	170	-0.2148	-0.2734	-6.8994	-2.2412	120	0.0098	0.4932	1.04	0.1758
21	0.249	0.4443	1.0889	-0.874	71	-0.2344	-0.2686	-5.6348	-1.958	121	0.0537	0.4932	1.0693	0.3613	171	-0.2197	-0.2734	0.9961	-1.2939	121	0.0537	0.4932	1.0693	0.3613
22	0.0098	0.4102	1.1133	0.0928	72	-0.2637	-0.2637	0.9717	-1.1621	122	0.1221	0.4785	-1.5576	-0.4443	172	-0.2539	-0.2783	0.9863	-0.5225	122	0.1221	0.4785	-1.5576	-0.4443
23	-0.1123	0.3418	1.0986	0.2344	73	-0.2441	-0.2588	0.9717	-0.4297	123	0.1709	0.4541	1.0889	-0.0586	173	-0.2393	-0.2734	-10	-4.0088	123	0.1709	0.4541	1.0889	-0.0586
24	-0.127	0.2734	1.1182	0.3906	74	-0.2637	-0.2441	-10	-4.1211	124	0.166	0.4004	1.1084	0.1953	174	-0.2539	-0.2686	0.9688	-2.6074	124	0.166	0.4004	1.1084	0.1953
25	-0.1563	0.1758	-0.1123	0.0195	75	-0.2734	-0.2148	0.9717	-2.6318	125	-0.0488	0.3369	-9.5313	-2.9004	175	-0.2637	-0.2588	0.9688	-1.084	125	-0.0488	0.3369	-9.5313	-2.9004
26	-0.1807	0.0879	1.0986	0.2441	76	-0.2734	-0.166	0.9717	-1.1182	126	-0.1367	0.2539	1.0938	-1.8506	176	-0.2588	-0.2441	0.9473	-0.5908	126	-0.1367	0.2539	1.0938	-1.8506
27	-0.1172	-0.0049	1.1035	0.3516	77	-0.2588	-0.1025	0.9619	-0.5518	127	-0.1221	0.1709	1.0938	-0.5566	177	-0.2637	-0.2051	0.9688	-0.2197	127	-0.1221	0.1709	1.0938	-0.5566
28	-0.1465	-0.083	-7.2314	-2.1436	78	-0.2783	-0.0098	0.9814	-0.6494	128	-0.1855	0.083	1.0645	-0.21	178	-0.2783	-0.1563	-1.4404	-0.8057	128	-0.1855	0.083	1.0645	-0.21
29	-0.1318	-0.1514	1.0742	-1.4307	79	-0.2686	0.0879	0.8105	0.0439	129	-0.2002	-0.0049	1.0889	0.1074	179	-0.2832	-0.0781	0.9619	-0.3516	129	-0.2002	-0.0049	1.0889	0.1074
30	-0.2051	-0.1904	1.0645	-0.3662	80	-0.2637	0.1758	0.9961	0.1563	130	-0.1807	-0.0879	-4.7021	-1.6064	180	-0.2832	0	0.9863	-0.0391	130	-0.1807	-0.0879	-4.7021	-1.6064
31	-0.2148	-0.2295	1.0449	-0.0977	81	-0.2246	0.2588	1.0156	0.2832	131	-0.1758	-0.1465	1.0645	-0.9766	181	-0.2686	0.083	-4.5557	-1.5967	131	-0.1758	-0.1465	1.0645	-0.9766
32	-0.2002	-0.2393	1.0645	0.1416	82	-0.2246	0.3271	-1.5674	-0.4834	132	-0.1855	-0.2002	1.0449	-0.2637	182	-0.2588	0.1563	0.9912	-0.8691	132	-0.1855	-0.2002	1.0449	-0.2637
33	-0.2002	-0.2588	-5.5078	-1.8115	83	-0.1758	0.3906	1.0205	-0.1367	133	-0.2002	-0.2295	1.0352	0.0293	183	-0.249	0.2344	1.0107	-0.21	133	-0.2002	-0.2295	1.0352	0.0293
34	-0.2246	-0.2637	1.0303	-1.0449	84	-0.1318	0.4443	1.0498	0.1514	134	-0.2051	-0.249	1.0254	0.1221	184	-0.2393	0.3027	-7.8809	-2.7148	134	-0.2051	-0.249	1.0254	0.1221
35	-0.2197	-0.2686	1.0156	-0.3564	85	-0.0781	0.4785	1.04	0.3027	135	-0.21	-0.2588	-1.5527	-0.5615	185	-0.2393	0.376	1.0254	-1.6504	135	-0.21	-0.2588	-1.5527	-0.5615
36	-0.2148	-0.2686	-10	-3.5791	86	0.0195	0.4932	1.0693	0.3613	136	-0.2148	-0.2734	0.9961	-0.2393	186	-0.1855	0.4248	1.04	-0.5762	136	-0.2148	-0.2734	0.9961	-0.2393
37	-0.2393	-0.2686	0.9814	-2.2412	87	0.1123	0.498	0.2441	0.1855	137	-0.2344	-0.2734	1.0254	0.0781	187	-0.1611	0.4688	1.0303	-0.166	137	-0.2344	-0.2734	1.0254	0.0781
38	-0.2588	-0.2637	0.9814	-0.9424	88	0.2148	0.4932	1.0791	0.2979	138	-0.2539	-0.2734	-4.292	-1.5137	188	-0.0732	0.4932	1.0547	0.0977	138	-0.2539	-0.2734	-4.292	-1.5137
39	-0.2686	-0.2539	0.9619	-0.4834	89	0.2344	0.459	1.1035	0.4688	139	-0.2441	-0.2734	0.9766	-0.8154	189	0.0049	0.498	-3.9014	-1.2793	139	-0.2441	-0.2734	0.9766	-0.8154
40	-0.2686	-0.2393	0.9766	-0.8008	90	0.0439	0.4102	-6.1768	-1.7676	140	-0.2539	-0.2686	0.9619	-0.3125	190	0.0928	0.4834	1.0693	-0.7373	140	-0.2539	-0.2686	0.9619	-0.3125
41	-0.2734	-0.2148	0.7275	0.0439	91	-0.1221	0.3369	1.1035	-0.9521	141	-0.2588	-0.2588	-10	-3.8281	191	0.1123	0.4492	1.0938	-0.0684	141	-0.2588	-0.2588	-10	-3.8281
42	-0.2832	-0.166	0.9619	0.1563	92	-0.1709	0.2539	1.1182	-0.2197	142	-0.2686	-0.249	0.9521	-2.5439	192	0.127	0.4004	1.084	0.1563	142	-0.2686	-0.249	0.9521	-2.5439
43	-0.2783	-0.1025	0.9766	0.2295	93	-0.1611	0.166	1.0889	0.0879	143	-0.2734	-0.21	0.957	-0.9961	193	0.1074	0.3369	1.0938	0.293	143	-0.2734	-0.21	0.957	-0.9961
44	-0.2832	-0.0146	-1.626	-0.5371	94	-0.166	0.0781	1.0986	-0.1025	144	-0.2686	-0.166	0.9473	-0.5469	194	0.0146	0.2588	-0.5713	-0.1514	144	-0.2686	-0.166	0.9473	-0.5469
45	-0.2588	0.0781	0.9814	-0.1709	95	-0.1172	-0.0146	0.7373	0.293	145	-0.2979	-0.0928	0.9814	-0.1563	195	-0.1855	0.1807	1.0693	0.0488	145	-0.2979	-0.0928	0.9814	-0.1563
46	-0.2539	0.1709	1.0352	0.1221	96	-0.1465	-0.0928	1.0742	0.3027	146	-0.2686	0	-1.4209	-0.7715	196	-0.2197	0.0977	1.0791	0.2588	146	-0.2686	0	-1.4209	-0.7715
47	-0.2588	0.2539	-3.9502	-1.3135	97	-0.1758	-0.1514	1.084	0.429															



Tinggi Gel 2 cm  
Periode 1.8 dt

No	Load cell (Volt)	Seasim (Volt)	Trimmeter 1 (Volt)	Trimmeter 2 (Volt)	No	Load cell (Volt)	Seasim (Volt)	Trimmeter 1 (Volt)	Trimmeter 2 (Volt)	No	Load cell (Volt)	Seasim (Volt)	Trimmeter 1 (Volt)	Trimmeter 2 (Volt)	No	Load cell (Volt)	Seasim (Volt)	Trimmeter 1 (Volt)	Trimmeter 2 (Volt)
1	0.2246	0.4932	1.0889	0.2344	51	-0.2148	-0.2637	-1.3037	-0.5566	101	-0.21	0.2441	1.0205	-0.3467	151	-0.1318	0.0781	1.0889	0.2197
2	0.0391	0.4639	1.1084	0.6445	52	-0.2197	-0.2686	0.9668	-0.2979	102	-0.1025	0.3174	1.0645	0.0391	152	-0.1221	-0.0146	1.0498	0.2734
3	-0.1025	0.4102	1.0889	0.5615	53	-0.2246	-0.2686	0.9766	0.083	103	-0.0293	0.376	-8.3154	-2.7197	153	-0.1611	-0.0879	1.0596	0.3662
4	-0.1416	0.3516	1.0986	0.6104	54	-0.2441	-0.2734	-10	-3.5693	104	0.0439	0.4346	1.0791	-1.7578	154	-0.166	-0.1514	-3.4766	-1.0547
5	-0.1416	0.2783	-2.4805	-0.5762	55	-0.249	-0.2686	0.9619	-2.4072	105	0.1904	0.4736	1.0693	-0.5127	155	-0.1807	-0.1904	1.0254	-0.6104
6	-0.166	0.1904	1.0791	-0.2539	56	-0.2344	-0.2637	0.1758	-1.1523	106	0.2832	0.5029	1.0938	-0.0684	156	-0.1953	-0.2295	1.0254	-0.0928
7	-0.1221	0.0977	1.0791	0.1514	57	-0.249	-0.2539	0.9277	-0.5908	107	0.2002	0.5078	1.1182	0.1563	157	-0.2002	-0.2441	0.9961	0.1025
8	-0.1465	0.0049	1.0498	0.3027	58	-0.2637	-0.2393	0.957	-0.2197	108	-0.0342	0.5029	-4.6191	-1.4111	158	-0.2002	-0.2588	0.9912	-0.3857
9	-0.1709	-0.083	1.084	0.3369	59	-0.2686	-0.2197	-10	-3.6572	109	-0.1172	0.4834	1.1035	-0.791	159	-0.1855	-0.2637	0.9768	0.3564
10	-0.1758	-0.1563	-5.6396	-1.6699	60	-0.2441	-0.1709	0.9619	-2.4561	110	-0.0049	0.4492	1.1328	-0.0732	160	-0.21	-0.2783	0.9619	0.293
11	-0.1611	-0.2051	1.0254	-1.0938	61	-0.2539	-0.1074	0.9668	-0.918	111	-0.1221	0.3955	1.0889	0.1123	161	-0.2295	-0.2686	0.9717	0.3564
12	-0.166	-0.2344	1.04	-0.2588	62	-0.2588	-0.0195	0.9717	-0.4785	112	-0.083	0.3369	1.1182	-0.2393	162	-0.2393	-0.2734	-4.5996	-1.4355
13	-0.1807	-0.249	0.9912	-0.0586	63	-0.2246	0.0732	1.0059	-0.1025	113	-0.1367	0.2539	1.0791	0.4492	163	-0.249	-0.2686	0.957	-0.8936
14	-0.1807	-0.2588	0.9912	-0.5273	64	-0.2295	0.166	-1.0352	-0.6006	114	-0.1416	0.1709	1.0889	0.498	164	-0.249	-0.2637	0.9521	-0.2734
15	-0.1904	-0.2686	0.4639	0.1416	65	-0.1904	0.2441	1.0205	-0.1953	115	-0.1367	0.0781	1.084	0.4736	165	-0.249	-0.2441	0.9473	-0.0098
16	-0.2539	-0.2686	0.9521	0.2197	66	-0.1904	0.3174	1.04	0.1123	116	-0.1367	-0.0195	-10	-3.0078	166	-0.2637	-0.2344	0.9521	0.0732
17	-0.2441	-0.2686	0.9619	0.2783	67	-0.1465	0.3809	-10	-3.4375	117	-0.1465	-0.0977	1.0498	-2.1289	167	-0.2539	-0.2051	-2.1191	-0.7617
18	-0.2295	-0.2686	-9.4824	-2.9297	68	-0.0488	0.4297	1.0547	-1.7578	118	-0.1758	-0.1611	-0.0195	-0.9277	168	-0.249	-0.1611	0.9619	-0.415
19	-0.2295	-0.2637	0.9424	-2.0654	69	0.0635	0.4639	-0.6934	-1.3721	119	-0.1855	-0.2002	1.0254	-0.498	169	-0.249	-0.0928	1.001	0.0391
20	-0.2441	-0.2637	0.2441	-0.8984	70	0.1563	0.4883	1.0791	-0.7275	120	-0.1807	-0.2295	1.0303	-0.0537	170	-0.2441	-0.0049	-7.666	-2.5488
21	-0.2734	-0.2539	0.9277	-0.4932	71	0.2344	0.4932	1.0986	-0.1465	121	-0.2051	-0.2441	-7.3877	-2.5342	171	-0.2295	0.0879	1.0107	-1.499
22	-0.2686	-0.2393	0.9424	-0.0977	72	0.2588	0.4932	1.0791	0.0879	122	-0.2295	-0.2588	0.9912	-1.5186	172	-0.2344	0.1758	1.0156	-0.5713
23	-0.2588	-0.2148	-10	-4.1748	73	0.0488	0.4785	1.1084	-0.2979	123	-0.2295	-0.2637	0.9766	-0.6299	173	-0.2393	0.2637	1.0205	-0.1416
24	-0.2734	-0.1758	0.9521	-2.8662	74	-0.0928	0.4492	1.0938	0.4688	124	-0.2197	-0.2686	0.9473	-0.2441	174	-0.1953	0.332	1.04	0.0537
25	-0.2832	-0.1123	0.0732	-1.3379	75	-0.1465	0.4004	1.0938	0.498	125	-0.2344	-0.2734	0.9521	-0.0781	175	-0.0635	0.4053	-2.8857	-0.9619
26	-0.2783	-0.0342	0.9619	-0.6885	76	-0.0977	0.3418	1.1133	0.5225	126	-0.249	-0.2734	-2.4463	-0.9717	176	0.0537	0.4541	1.04	-0.6201
27	-0.2686	0.0635	1.0352	-0.2295	77	-0.1416	0.2686	-6.3574	-1.7676	127	-0.2637	-0.2734	0.9326	-0.6641	177	0.1514	0.4883	1.084	0.0586
28	-0.2295	0.1514	-3.8379	-1.5137	78	-0.1074	0.1855	1.0791	-1.1475	128	-0.249	-0.2637	0.9375	-0.1172	178	0.21	0.498	1.0693	0.1904
29	-0.2344	0.2393	1.0107	-0.8252	79	-0.127	0.0928	1.0742	-0.2148	129	-0.2637	-0.249	0.9277	-0.0049	179	0.2637	0.498	1.0986	0.3857
30	-0.1807	0.3125	1.0352	-0.2197	80	-0.1563	-0.0049	1.0547	0.0342	130	-0.2539	-0.2344	0.9473	0.1465	180	0.2002	0.4883	-3.2031	-0.9326
31	-0.1514	0.3857	1.0254	0.0635	81	-0.1807	-0.0977	1.0693	0.2148	131	-0.2441	-0.21	-3.916	-1.3428	181	-0.0537	0.4688	1.0986	-0.415
32	-0.083	0.4346	1.0547	0.2148	82	-0.1855	-0.1611	-9.7461	-3.042	132	-0.2441	-0.166	0.9521	-0.8154	182	-0.1221	0.4346	1.1084	0.0537
33	0.0342	0.4785	-2.8662	-0.8691	83	-0.1758	-0.2051	1.0352	-2.0557	133	-0.2539	-0.0977	0.9619	-0.2197	183	-0.0781	0.3809	1.1768	0.2979
34	0.1758	0.5078	1.0742	-0.4883	84	-0.1758	-0.2295	1.0156	-0.6836	134	-0.2588	-0.0146	0.957	0.0098	184	-0.1318	0.3223	1.0986	0.3467
35	0.2832	0.5176	1.1084	0.1074	85	-0.1709	-0.2441	1.001	-0.3027	135	-0.2393	0.0781	1.001	-0.3857	185	-0.1514	0.249	-0.6836	-0.1221
36	0.293	0.5078	1.0889	0.2441	86	-0.21	-0.2539	0.9961	-0.0342	136	-0.2393	0.1611	1.001	0.3467	186	-0.1416	0.166	1.0645	-0.0098
37	0.0293	0.4932	1.1182	0.4053	87	-0.21	-0.2637	-2.3535	-0.9668	137	-0.2588	0.249	1.0059	0.3564	187	-0.166	0.083	1.0742	0.2979
38	-0.0635	0.4492	0.8594	0.3369	88	-0.2246	-0.2686	0.9766	-0.498	138	-0.2344	0.3223	1.0254	0.4199	188	-0.1514	0	1.04	0.3125
39	-0.0879	0.4004	1.1084	0.459	89	-0.2441	-0.2734	0.9766	-0.0781	139	-0.1855	0.3906	-5.0732	-1.4551	189	-0.166	-0.083	1.0449	0.3906
40	-0.0732	0.3271	1.1133	0.4834	90	-0.2344	-0.2686	-10	-3.5303	140	-0.0781	0.4443	1.0498	-0.9424	190	-0.1904	-0.1514	-3.2959	-0.9863
41	-0.1221	0.2588	-5.5127	-1.499	91	-0.2344	-0.2734	0.957	-2.3877	141	0.0391	0.4883	1.0791	-0.0928	191	-0.1855	-0.1953	1.0254	-0.5371
42	-0.1025	0.1807	1.0889	-0.9521	92	-0.249	-0.2588	0.9277	-0.9082	142	0.1904	0.5029	1.0645	0.1465	192	-0.1758	-0.2295	1.0254	-0.0732
43	-0.127	0.0977	1.0938	-0.1172	93	-0.249	-0.2539	0.9521	-0.4785	143	0.2783	0.5078	1.1035	0.332	193	-0.2002	-0.249	-10	-4.0088
44	-0.1123	-0.0049	1.0596	-0.0586	94	-0.2539	-0.2344	0.9766	-0.127	144	0.2832	0.498	-6.0693	-1.792	194	-0.2051	-0.2588	0.9912	-2.5928
45	-0.1416	-0.0879	1.1035	0.2783	95	-0.2344	-0.2148	-4.0967	-1.5723	145	0.0244	0.4785	1.1035	-1.0449	195	-0.2051	-0.2686	0.9717	-1.0547
46	-0.1758	-0.1563	-7.4805	-2.3486	96	-0.2344	-0.166	0.9814	-0.8594	146	-0.0684	0.4346	1.1133	-0.2051	196	-0.2197	-0.2734	0.957	-0.5566
47	-0.166	-0.2051	1.0449	-1.5283	97	-0.2539	-0.1123	1.0107	-0.3174	147	-0.0928	0.3809	1.0938	0.0879	197	-0.2393	-0.2734	0.9619	-0.2051
48	-0.1855	-0.2344	1.0156	-0.4932	98	-0.2441	-0.0146	-9.6777	-3.3105	148	-0.1123	0.3174	1.1035	0.2441	198	-0.2344	-0.2734	-3.6865	-1.4844
49	-0.1855	-0.249	1.0059	-0.1318	99	-0.2393	0.0732	1.0156	-2.1533	149	-0.1514	0.2441	-1.1523	-0.3418	199	-0.2295	-0.2686	0.9473	-0.9326
50	-0.1904	-0.2588	0.9912	0.0146	100	-0.249	0.166	1.0303	-0.7568	150	-0.1221	0.1563	1.0791	-0.1221	200	-0.2539	-0.2637	0.9521	-0.3027



No	Load cell (Volt)	Seasim (Volt)	Trimmeter 1 (Volt)	Trimmeter 2 (Volt)	No	Load cell (Volt)	Seasim (Volt)	Trimmeter 1 (Volt)	Trimmeter 2 (Volt)	No	Load cell (Volt)	Seasim (Volt)	Trimmeter 1 (Volt)	Trimmeter 2 (Volt)	No	Load cell (Volt)	Seasim (Volt)	Trimmeter 1 (Volt)	Trimmeter 2 (Volt)
1	-0.2002	0.2588	1.1133	0.3711	51	-0.293	-0.2832	0.9229	0.2197	101	-0.249	0.1758	-10	-3.2422	151	-0.1709	0.4248	1.0742	0.2783
2	-0.2246	0.1758	1.0889	0.5762	52	-0.3027	-0.2832	0.9424	0.2637	102	-0.1709	0.249	1.0352	-2.207	152	-0.2148	0.3662	1.0889	0.415
3	-0.2295	0.0879	1.0449	0.5371	53	-0.3125	-0.2832	-3.5107	-1.123	103	-0.1123	0.332	-0.4932	-1.1328	153	-0.2295	0.2832	-3.9307	-1.1328
4	-0.2002	-0.0098	1.0547	0.542	54	-0.3271	-0.2734	0.9375	-0.791	104	-0.0439	0.3906	1.0596	-0.6299	154	-0.2051	0.1904	1.0742	-0.7471
5	-0.21	-0.0977	-8.999	-2.5977	55	-0.3174	-0.2686	0.9375	-0.1465	105	0.0195	0.4492	1.0889	-0.0684	155	-0.2148	0.0879	1.0498	-0.0342
6	-0.2295	-0.1709	1.0449	-1.8164	56	-0.3271	-0.2539	0.9375	0.0146	106	0.1318	0.4932	1.0693	0.1514	156	-0.2344	-0.0146	1.04	0.1611
7	-0.2441	-0.21	0.7373	-0.5859	57	-0.3174	-0.2393	0.9863	0.1807	107	0.2344	0.5273	1.1035	0.3174	157	-0.249	-0.1074	1.0352	0.2686
8	-0.249	-0.2441	1.001	-0.21	58	-0.3125	-0.21	-6.665	-2.1387	108	0.0879	0.542	-2.1289	-0.5957	158	-0.2637	-0.166	-9.5215	-2.9297
9	-0.2441	-0.2539	1.0254	0.0293	59	-0.3125	-0.166	0.9668	-1.3428	109	-0.1465	0.5518	1.1084	-0.2197	159	-0.2441	-0.2148	1.0107	-1.9238
10	-0.2637	-0.2734	-5.957	-1.9873	60	-0.3076	-0.1025	1.001	-0.4541	110	-0.1807	0.5371	1.123	0.1953	160	-0.2637	-0.2393	1.001	-0.6738
11	-0.2832	-0.2783	0.9912	-1.2598	61	-0.3125	-0.0195	0.9912	-0.1221	111	-0.0879	0.5127	1.1084	0.3271	161	-0.2588	-0.2588	0.9766	-0.3076
12	-0.2832	-0.2832	0.9814	-0.4199	62	-0.3223	0.0781	1.0205	0.0684	112	-0.21	0.4688	1.1035	0.4248	162	-0.2881	-0.2686	0.9814	-0.0439
13	-0.3076	-0.2832	0.9619	-0.1758	63	-0.2588	0.166	-1.2695	-0.4932	113	-0.1367	0.4199	0.2051	0.166	163	-0.293	-0.2783	-3.6719	-1.3721
14	-0.2881	-0.2832	0.9668	0.0488	64	-0.21	0.2539	1.04	-0.2686	114	-0.1904	0.3467	1.084	0.2637	164	-0.3076	-0.2832	0.957	-0.9082
15	-0.3027	-0.2783	-2.2021	-0.8838	65	-0.083	0.332	1.0596	0.1709	115	-0.21	0.2734	1.1035	0.3906	165	-0.3125	-0.2881	0.9424	-0.2637
16	-0.3027	-0.2734	0.9668	-0.4688	66	0.0049	0.4102	1.1572	0.293	116	-0.2197	0.1807	1.0498	0.4395	166	-0.3125	-0.2881	0.9326	-0.0635
17	-0.293	-0.2637	0.9863	-0.1025	67	0.0879	0.4639	1.1426	0.4541	117	-0.2148	0.0879	1.0596	0.4297	167	-0.3027	-0.2881	0.957	0.0977
18	-0.2881	-0.2539	-10	-3.9648	68	0.1904	0.5078	-5.7617	-1.6455	118	-0.2148	-0.0195	-4.7314	-1.333	168	-0.3125	-0.2783	-7.4707	-2.4414
19	-0.3027	-0.2295	1.001	-2.6074	69	0.2686	0.5371	1.0986	-0.9521	119	-0.2295	-0.1074	1.0303	-0.9131	169	-0.3027	-0.2734	0.9424	-1.6943
20	-0.3027	-0.2051	1.001	-0.9961	70	0.0586	0.5489	1.1182	-0.1367	120	-0.2441	-0.1709	1.0254	-0.127	170	-0.3076	-0.2588	0.9668	-0.5664
21	-0.2734	-0.1465	1.001	-0.5225	71	-0.1074	0.5322	1.1035	0.1758	121	-0.2588	-0.21	1.001	0.0195	171	-0.2979	-0.249	0.957	-0.2246
22	-0.2783	-0.083	1.0352	-0.1074	72	-0.166	0.5127	1.123	0.2979	122	-0.249	-0.2393	1.001	0.1855	172	-0.3027	-0.2197	0.9961	-0.0098
23	-0.2881	0.0049	-6.0449	-2.1387	73	-0.0781	0.4785	-1.0986	-0.249	123	-0.2588	-0.2539	-1.4648	-0.5762	173	-0.2832	-0.1807	-4.5801	-1.5918
24	-0.2637	0.0928	1.0449	-1.4063	74	-0.2197	0.4443	1.1084	-0.0098	124	-0.2832	-0.2686	0.9668	-0.2539	174	-0.2832	-0.1172	1.001	-0.9619
25	-0.1514	0.1758	1.0352	-0.3857	75	-0.0879	0.3906	1.123	0.3076	125	-0.293	-0.2783	0.9717	0.0146	175	-0.2783	-0.0293	1.0205	-0.2637
26	-0.0293	0.2539	1.0645	-0.0293	76	-0.1904	0.332	1.084	0.3369	126	-0.2979	-0.2881	0.9375	0.1514	176	-0.2783	0.0732	1.0059	-0.0391
27	0.127	0.3223	1.084	0.1855	77	-0.1709	0.2588	1.0986	0.4541	127	-0.3027	-0.2832	0.9473	0.166	177	-0.2588	0.1611	1.0303	0.1758
28	0.2734	0.3857	-3.0908	-1.0645	78	-0.2148	0.1807	-0.8057	-0.1758	128	-0.3174	-0.293	-2.7393	-0.8984	178	-0.2393	0.2441	-2.0068	-0.7031
29	0.2832	0.4395	1.1133	-0.9619	79	-0.2393	0.0879	1.0693	-0.0195	129	-0.3174	-0.2832	0.9375	-0.6641	179	-0.1563	0.3174	1.0498	-0.3906
30	0.0928	0.4834	1.1279	0.1318	80	-0.2246	-0.0098	1.0498	0.2393	130	-0.3271	-0.2832	0.9473	-0.0635	180	-0.0928	0.3955	1.0693	0.0977
31	-0.0928	0.5176	1.1133	0.2588	81	-0.2344	-0.0928	1.0303	0.3418	131	-0.3223	-0.2734	0.9277	0.0146	181	-0.0391	0.4541	1.0693	0.2881
32	-0.0537	0.5371	1.167	0.4688	82	-0.2393	-0.1611	1.0205	0.332	132	-0.3174	-0.2588	0.9619	0.1904	182	0.0732	0.5078	1.1035	0.376
33	0.0049	0.542	-4.1162	-1.1475	83	-0.2051	-0.2051	-3.8818	-1.1377	133	-0.2979	-0.2393	-5.4639	-1.8066	183	0.1953	0.5371	-6.9043	-1.9775
34	-0.0977	0.5273	1.1426	-0.5273	84	-0.249	-0.2393	1.0059	-0.6885	134	-0.3027	-0.2051	0.9766	-1.0889	184	0.1758	0.5518	1.1035	-1.2939
35	-0.0195	0.498	1.1377	0.0146	85	-0.2588	-0.2588	1.001	-0.1074	135	-0.3125	-0.166	0.9717	-0.3711	185	-0.0781	0.5489	1.1035	-0.2148
36	-0.1221	0.459	1.1182	0.2783	86	-0.2783	-0.2686	-0.3076	-0.542	136	-0.3174	-0.0977	0.9912	-0.0537	186	-0.1563	0.5371	1.0889	0.0342
37	-0.0977	0.4004	1.1182	0.3418	87	-0.2783	-0.2783	0.9766	-0.7861	137	-0.3271	-0.0146	1.001	-0.0586	187	-0.1709	0.5078	1.1133	0.3027
38	-0.1709	0.332	0.5908	0.2881	88	-0.3027	-0.2881	-0.7764	-0.4199	138	-0.3076	0.0781	0.0098	-0.0537	188	-0.1855	0.4785	-7.0459	-2.1533
39	-0.2002	0.2539	1.0889	0.3125	89	-0.3076	-0.2832	0.9521	-0.2002	139	-0.2588	0.1611	1.0107	0.0488	189	-0.2295	0.4297	1.0889	-1.3867
40	-0.2002	0.1709	1.1035	0.4785	90	-0.3174	-0.293	0.9326	0.0342	140	-0.2246	0.2441	1.0547	0.2979	190	-0.1807	0.3613	1.0547	-0.3369
41	-0.2197	0.0732	1.0547	0.4297	91	-0.3125	-0.2832	0.9326	0.1709	141	-0.1807	0.3174	1.0254	0.3125	191	-0.21	0.2881	1.0693	-0.0146
42	-0.21	-0.0195	1.0645	0.4736	92	-0.3174	-0.2832	0.9424	0.1855	142	-0.1221	0.3809	1.0742	0.4443	192	-0.21	0.1953	1.0596	0.1416
43	-0.2246	-0.1172	-3.0615	-0.8594	93	-0.3076	-0.2686	-4.1992	-1.3428	143	-0.0146	0.4395	-3.3691	-0.9473	193	-0.2441	0.0977	1.0449	0.293
44	-0.2295	-0.1709	1.0303	-0.498	94	-0.3271	-0.2637	0.9473	-0.9277	144	0.127	0.4932	1.0938	-0.5029	194	-0.2539	-0.0049	1.0352	0.2979
45	-0.2344	-0.2197	1.0107	-0.0195	95	-0.3223	-0.2344	0.9668	-0.2002	145	0.2148	0.5273	1.0938	0.0732	195	-0.2393	-0.0977	-2.6563	-0.7764
46	-0.249	-0.2393	0.9912	0.1416	96	-0.3027	-0.2148	0.957	-0.0342	146	0.1172	0.5518	1.0938	0.3027	196	-0.2539	-0.166	1.0059	-0.4736
47	-0.2734	-0.2637	0.9863	0.0977	97	-0.293	-0.1611	1.001	0.1514	147	-0.1221	0.5518	1.1084	0.376	197	-0.2539	-0.21	1.0205	0.0098
48	-0.293	-0.2686	-0.3418	-0.1367	98	-0.293	-0.0928	-0.7324	-0.3467	148	-0.1709	0.5489	-2.5977	-0.6641	198	-0.2734	-0.2393	-10	-4.1162
49	-0.2979	-0.2783	0.9473	-0.0439	99	-0.3271	-0.0049	1.0059	-0.0488	149	-0.1172	0.5127	1.0986	-0.3271	199	-0.2637	-0.2588	0.9912	-2.666
50	-0.3027	-0.2783	0.9619	0.21	100	-0.3174	0.083	1.0254	0.1807	150	-0.1904	0.4834	1.1133	0.1855	200	-0.2734	-0.2734	0.791	-1.1523



Tinggi Gel 2 cm  
 Periode 2 dt

No	Load cell (Volt)	Seasim (Volt)	Trimmer 1 (Volt)	Trimmer 2 (Volt)	No	Load cell (Volt)	Seasim (Volt)	Trimmer 1 (Volt)	Trimmer 2 (Volt)	No	Load cell (Volt)	Seasim (Volt)	Trimmer 1 (Volt)	Trimmer 2 (Volt)	No	Load cell (Volt)	Seasim (Volt)	Trimmer 1 (Volt)	Trimmer 2 (Volt)
1	-0.293	-0.2539	0.9814	0.4736	51	0.083	0.415	-1.8408	-1.748	101	-0.1709	0.376	1.0693	-0.249	151	-0.2637	-0.2588	0.9668	0.0977
2	-0.293	-0.2393	-3.54	-0.9961	52	0.1709	0.4688	1.0791	-1.04	102	-0.2197	0.3076	1.0742	0.0977	152	-0.2832	-0.2686	-9.2578	-3.0566
3	-0.2734	-0.21	0.9912	-0.5469	53	0.2197	0.5176	1.1182	-0.2344	103	-0.2344	0.2197	1.0449	0.2295	153	-0.293	-0.2783	0.9473	-1.6406
4	-0.2588	-0.166	1.0254	-0.0488	54	0.0635	0.542	1.084	0.0098	104	-0.2393	0.127	1.0645	0.332	154	-0.2832	-0.2881	-2.0703	-1.7676
5	-0.2783	-0.0928	1.0059	0.1318	55	-0.1416	0.5518	1.123	0.2832	105	-0.2344	0.0342	-7.6318	-2.3096	155	-0.2783	-0.2881	0.9375	-1.1768
6	-0.2637	0	1.0303	0.2393	56	-0.1807	0.5518	-2.3535	-0.7373	106	-0.2539	-0.0537	1.0254	-1.5674	156	-0.2881	-0.2881	0.9619	-0.415
7	-0.2637	0.0977	-2.8955	-0.8887	57	-0.0977	0.5322	1.1133	-0.3076	107	-0.249	-0.127	1.001	-0.4541	157	-0.3027	-0.293	0.9277	-0.2051
8	-0.1953	0.1807	1.0449	-0.6152	58	-0.2051	0.5029	1.1035	0.1172	108	-0.249	-0.1758	0.9912	-0.1465	158	-0.3076	-0.293	0.9717	0.0439
9	-0.0977	0.2637	1.0645	0.0781	59	-0.1514	0.4688	1.0791	0.3223	109	-0.2393	-0.2148	0.9961	0.0488	159	-0.2979	-0.2832	-5.7959	-2.002
10	-0.0195	0.332	1.0547	0.2246	60	-0.21	0.4248	1.084	0.3662	110	-0.2734	-0.2393	-5.0391	-1.709	160	-0.2881	-0.2686	0.9814	-1.2744
11	0.1074	0.4102	1.0938	0.4053	61	-0.21	0.3711	-5.9717	-1.6992	111	-0.2637	-0.2588	0.9619	-1.1426	161	-0.2881	-0.2588	0.9766	-0.4492
12	0.21	0.4688	-10	-2.9932	62	-0.2393	0.3027	1.0693	-1.2744	112	-0.293	-0.2686	0.9668	-0.3467	162	-0.2979	-0.2295	0.9863	-0.1123
13	0.21	0.5176	1.1084	-1.9434	63	-0.2295	0.2344	0.4395	-0.3418	113	-0.2832	-0.2832	0.9473	-0.1221	163	-0.2979	-0.1953	0.9912	0.0244
14	-0.0146	0.5469	0.8398	-0.6152	64	-0.2148	0.1465	1.0352	-0.1855	114	-0.293	-0.2832	0.9912	0.0781	164	-0.3027	-0.1318	-2.1826	-0.8057
15	-0.1123	0.5615	1.1084	-0.127	65	-0.2148	0.0586	1.0449	0.1758	115	-0.2881	-0.2881	-8.6768	-2.8369	165	-0.2979	-0.0537	1.0107	-0.498
16	-0.1465	0.5518	1.123	0.166	66	-0.2344	-0.0293	1.0059	0.2051	116	-0.293	-0.2881	0.957	-1.9971	166	-0.2832	0.0391	1.0498	0.0244
17	-0.1465	0.5371	-8.7793	-2.6953	67	-0.2344	-0.1074	1.0205	0.3125	117	-0.2881	-0.2881	0.2051	-0.9082	167	-0.2295	0.1221	1.0156	0.1221
18	-0.1807	0.498	1.1035	-1.7725	68	-0.2295	-0.166	-1.3379	-0.459	118	-0.2979	-0.2832	0.9521	-0.4736	168	-0.1318	0.2051	1.0645	0.3174
19	-0.1318	0.4688	1.0986	-0.4492	69	-0.2344	-0.2148	0.9912	-0.1514	119	-0.3076	-0.2832	0.9668	-0.1074	169	-0.1074	0.2783	-7.5537	-2.3145
20	-0.1709	0.415	1.084	-0.1074	70	-0.2734	-0.2344	1.0498	0.127	120	-0.293	-0.2686	-10	-3.9453	170	-0.0098	0.3516	1.084	-1.6064
21	-0.1611	0.3662	1.0986	0.21	71	-0.293	-0.2588	-10	-3.9746	121	-0.2832	-0.2588	0.9863	-2.6611	171	0.0879	0.415	0.3906	-0.5615
22	-0.2148	0.3027	1.0547	0.2783	72	-0.2881	-0.2686	0.9619	-2.7832	122	-0.293	-0.2344	0.9473	-1.0352	172	0.1904	0.4834	1.0889	-0.1367
23	-0.249	0.2393	1.0742	0.3906	73	-0.2881	-0.2832	-0.9473	-1.5771	123	-0.2881	-0.1953	0.9863	-0.5371	173	0.2295	0.5273	1.1084	0.127
24	-0.2295	0.1514	-4.1455	-1.2305	74	-0.2881	-0.2783	0.9521	-1.001	124	-0.3223	-0.1416	1.0352	-0.1367	174	0.0342	0.5566	1.1035	0.332
25	-0.2246	0.0684	1.04	-0.8252	75	-0.2783	-0.2881	0.957	-0.3613	125	-0.3174	-0.0684	-6.7725	-2.373	175	-0.1318	0.5664	1.1133	0.3662
26	-0.2295	-0.0293	1.0205	-0.1025	76	-0.2783	-0.2881	0.9277	-0.1709	126	-0.3125	0.0244	1.0352	-1.582	176	-0.1709	0.5566	0.6396	0.332
27	-0.2246	-0.1074	1.0156	0.1172	77	-0.2979	-0.2881	0.9619	0.0537	127	-0.2393	0.1074	1.0205	-0.4883	177	-0.127	0.5322	1.0938	0.3564
28	-0.2344	-0.1709	1.0107	0.1953	78	-0.2832	-0.2832	-3.9941	-1.4404	128	-0.1416	0.1953	1.04	-0.1514	178	-0.21	0.5029	1.1084	0.542
29	-0.2783	-0.2051	-4.6973	-1.4795	79	-0.293	-0.2832	0.9717	-0.8887	129	-0.0781	0.2686	1.0645	0.0928	179	-0.1318	0.4639	0.957	0.4443
30	-0.2637	-0.2393	0.9717	-0.9717	80	-0.2979	-0.2734	0.9814	-0.2734	130	-0.0195	0.3467	1.0596	0.2686	180	-0.1807	0.4102	1.0938	0.5225
31	-0.2637	-0.2539	0.9814	-0.2393	81	-0.2783	-0.2637	0.9766	-0.0195	131	0.0684	0.4102	1.1035	0.3516	181	-0.1855	0.3613	-1.4453	-0.3174
32	-0.293	-0.2734	0.9424	-0.083	82	-0.2783	-0.2393	0.9961	0.0879	132	0.1953	0.4785	-3.8135	-1.0645	182	-0.2148	0.2881	1.0693	-0.1514
33	-0.2832	-0.2783	0.9619	0.1221	83	-0.2441	-0.2051	-0.7324	-0.3389	133	0.2197	0.5225	1.0986	-0.6299	183	-0.2246	0.21	1.0645	0.2295
34	-0.2881	-0.2881	-5.6885	-1.9189	84	-0.249	-0.1465	1.0059	-0.1367	134	-0.0049	0.5615	1.123	0.0684	184	-0.2246	0.1221	1.04	0.3467
35	-0.293	-0.2832	0.957	-1.3086	85	-0.2637	-0.0684	1.0303	0.1514	135	-0.127	0.5664	1.1084	0.2246	185	-0.2393	0.0391	1.0352	0.3613
36	-0.2832	-0.293	0.9277	-0.415	86	-0.2539	0.0293	1.0156	0.2197	136	-0.1758	0.5615	1.123	0.4053	186	-0.2393	-0.0488	-10	-3.0908
37	-0.3076	-0.2832	0.9473	-0.1123	87	-0.2197	0.1172	1.0449	0.3369	137	-0.127	0.5322	-2.8662	-0.8057	187	-0.2393	-0.1172	1.0156	-2.124
38	-0.3027	-0.2832	0.957	0.0391	88	-0.1367	0.2002	-3.7109	-1.1133	138	-0.2051	0.5127	1.1084	-0.376	188	-0.2295	-0.1807	0.9766	-0.6885
39	-0.3027	-0.2783	-10	-3.3691	89	-0.0684	0.2734	1.0596	-0.7568	139	-0.1221	0.4639	1.1084	0.1025	189	-0.2637	-0.2197	0.9863	-0.3418
40	-0.2832	-0.2734	0.9668	-2.3389	90	-0.0049	0.3418	1.0742	0.0098	140	-0.166	0.4297	1.0791	0.3027	190	-0.2637	-0.249	1.0059	-0.0244
41	-0.2979	-0.2588	0.7813	-0.874	91	0.1074	0.4053	1.0742	0.2246	141	-0.1807	0.3662	1.0889	0.3613	191	-0.2783	-0.2637	-6.5967	-2.2803
42	-0.3076	-0.2393	0.9668	-0.459	92	0.21	0.4639	1.1084	0.3711	142	-0.2295	0.3027	-8.291	-2.4268	192	-0.2783	-0.2734	0.9668	-1.5234
43	-0.293	-0.21	1.0352	-0.0732	93	0.2344	0.5127	-9.9805	-2.9492	143	-0.2197	0.2197	1.0547	-1.5723	193	-0.2881	-0.2783	0.9375	-0.542
44	-0.2783	-0.1611	-5.7764	-2.0459	94	-0.0146	0.5469	1.1133	-1.9336	144	-0.2246	0.1367	-0.8838	-1.0254	194	-0.2783	-0.2881	0.9424	-0.2002
45	-0.2539	-0.0781	1.0205	-1.2695	95	-0.1514	0.5615	1.1035	-0.5176	145	-0.2393	0.0488	1.0254	-0.6445	195	-0.2881	-0.2881	0.9521	-0.0146
46	-0.2832	0.0195	1.0205	-0.415	96	-0.1563	0.5615	1.1035	-0.1074	146	-0.2393	-0.0391	1.0498	-0.0732	196	-0.2881	-0.293	-10	-3.8428
47	-0.2588	0.1123	1.0254	-0.0537	97	-0.1416	0.5469	1.1133	0.1904	147	-0.2539	-0.1172	0.9961	0.0391	197	-0.293	-0.293	0.957	-2.7148
48	-0.2002	0.1953	1.0449	0.1318	98	-0.2051	0.5225	-8.5596	-2.6514	148	-0.2393	-0.1709	1.0205	0.2051	198	-0.2979	-0.2881	-0.7861	-1.5039
49	-0.1221	0.2783	-10	-3.5156	99	-0.1514	0.4883	1.0889	-1.792	149	-0.2686	-0.2148	-0.9766	-0.4248	199	-0.293	-0.2783	0.957	-0.9082
50	-0.0439	0.3467	1.0596	-1.8213	100	-0.1807	0.4395	0.625	-0.5908	150	-0.2686	-0.2393	0.9814	-0.1416	200	-0.293	-0.2734	1.0449	-0.2783



Grafik Gaya, Simpangan, dan Tinggi Gelombang  
Kondisi Sarat 6.5 cm, Tinggi Gel. 4 cm, Periode 1.2 dt

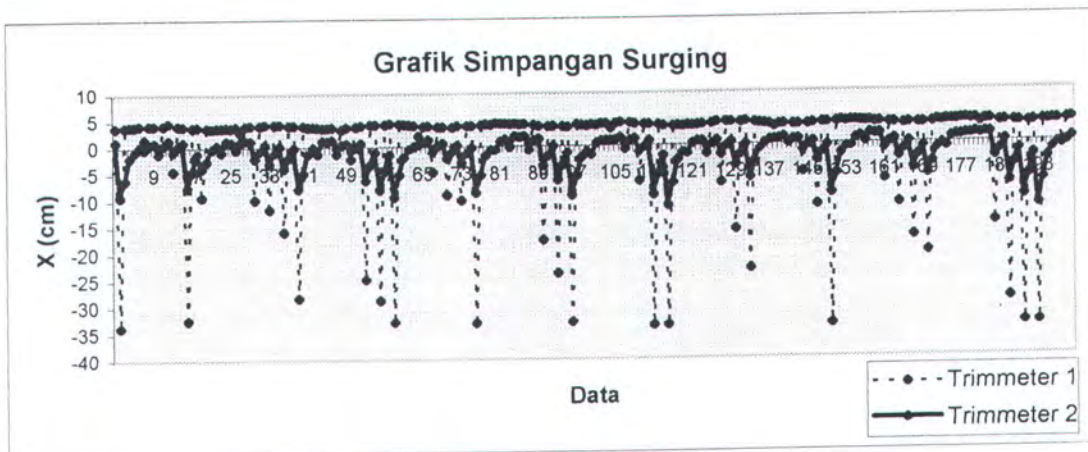
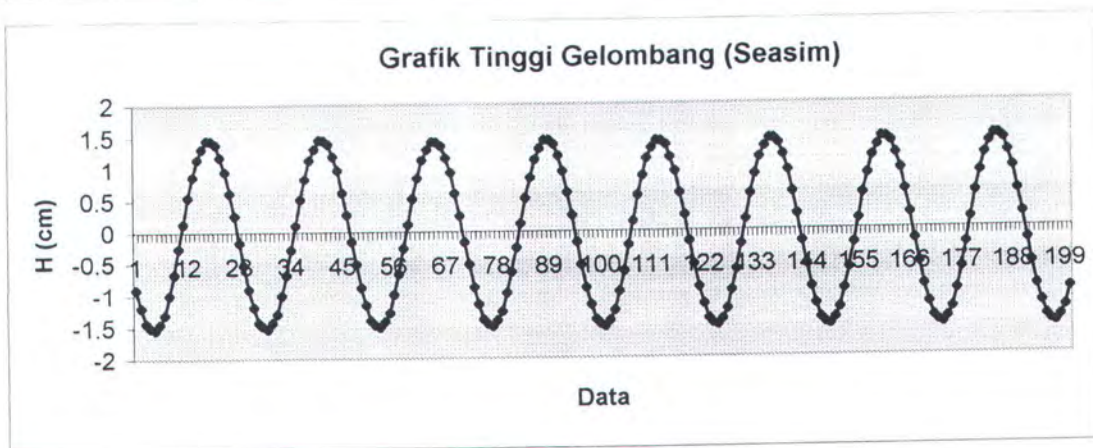
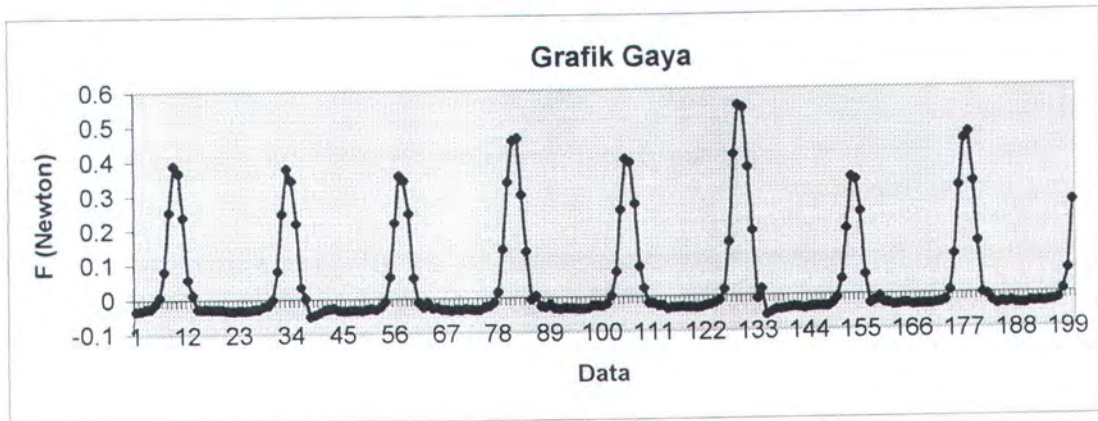



Grafik Gaya, Simpangan, dan Tinggi Gelombang  
Kondisi Sarat 6.5 cm, Tinggi Gel. 4 cm, Periode 1.3 dt

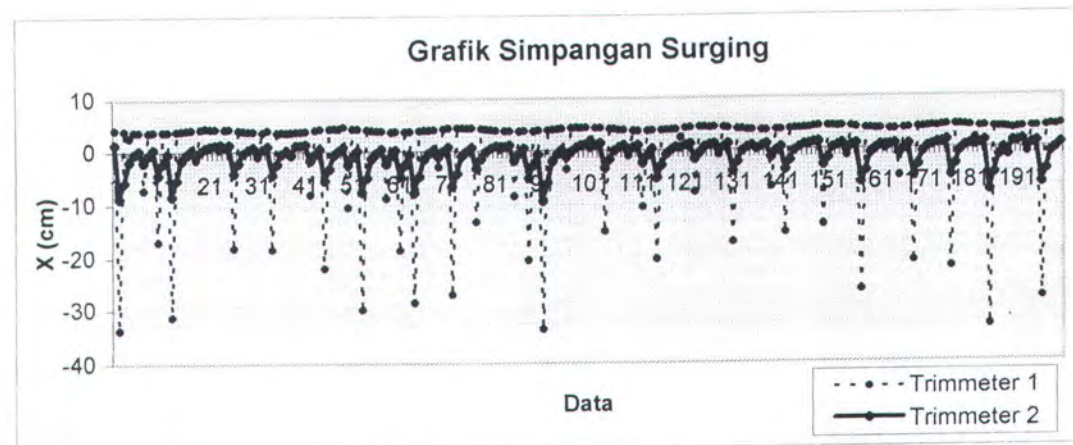
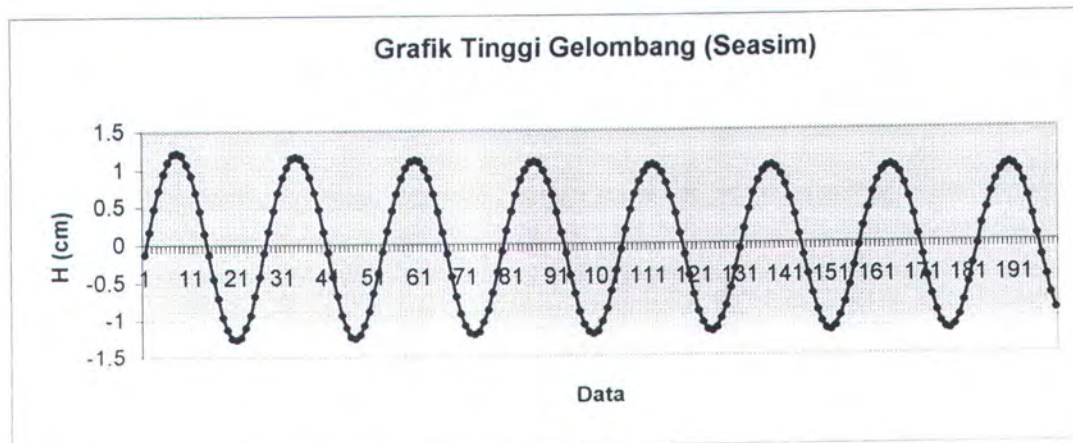
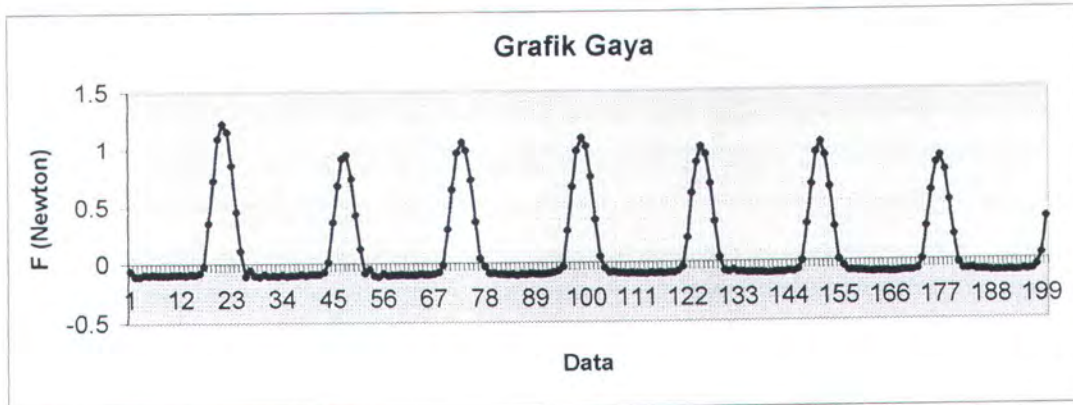



Grafik Gaya, Simpangan, dan Tinggi Gelombang  
Kondisi Sarat 6.5 cm, Tinggi Gel. 4 cm, Periode 1.4 dt

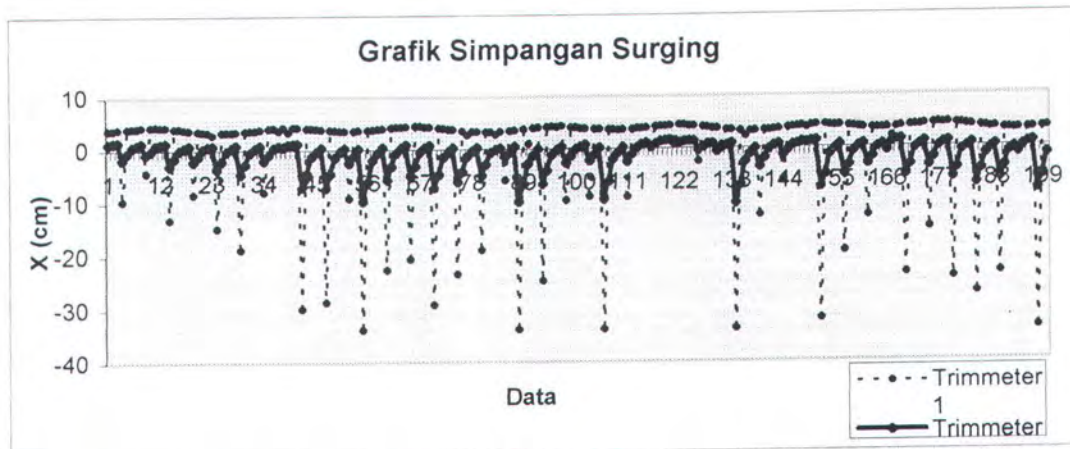
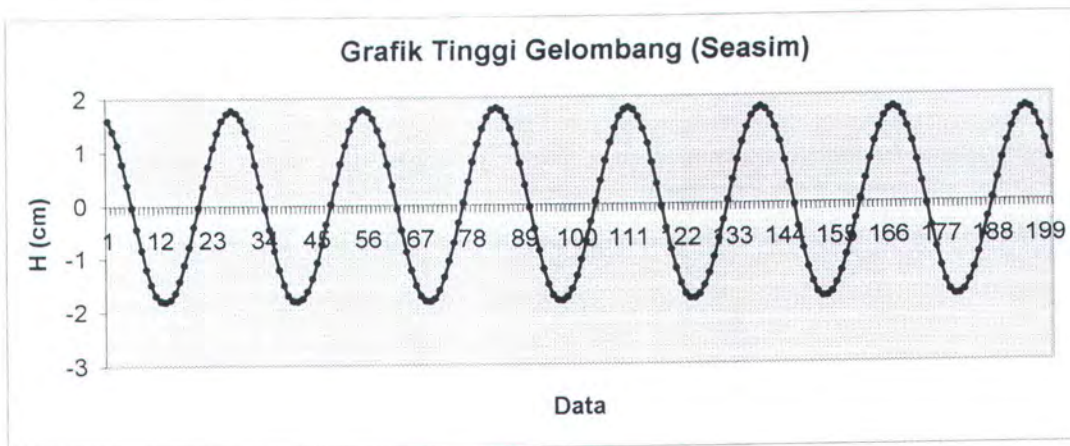
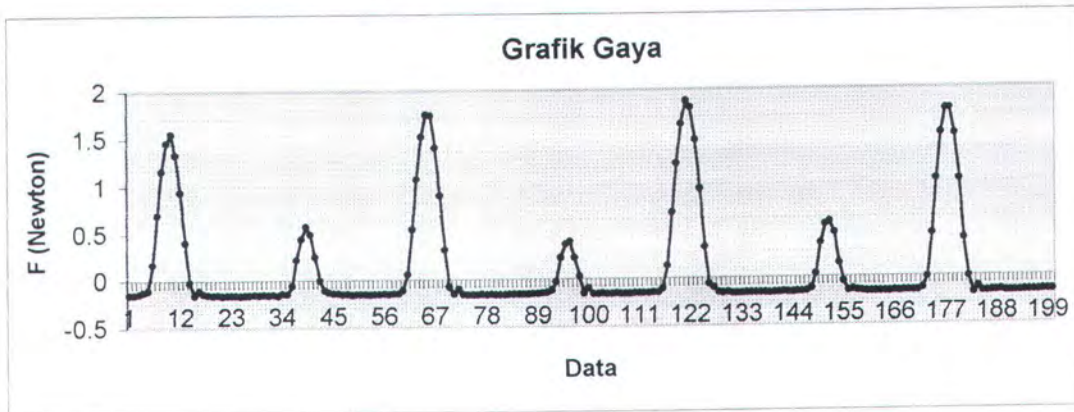



**Grafik Gaya, Simpangan, dan Tinggi Gelombang**  
 Kondisi Sarat 6.5 cm, Tinggi Gel. 4 cm, Periode 1.5 dt

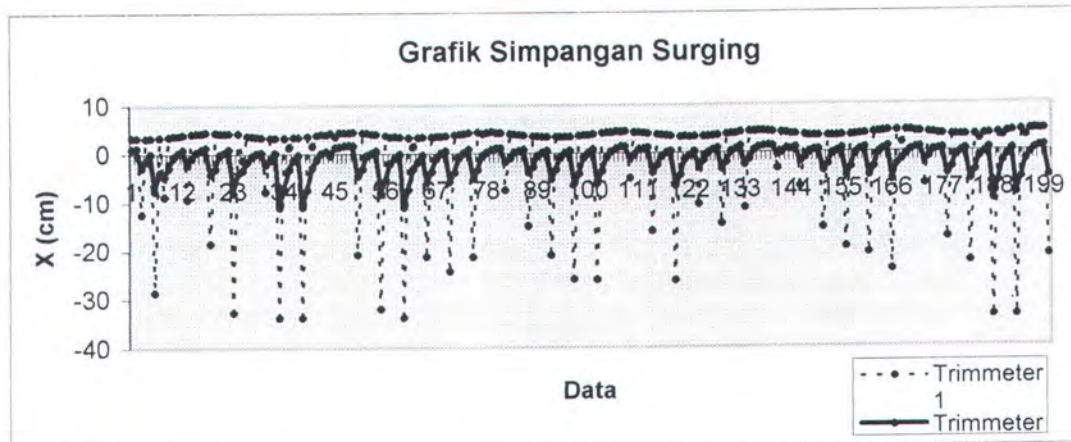
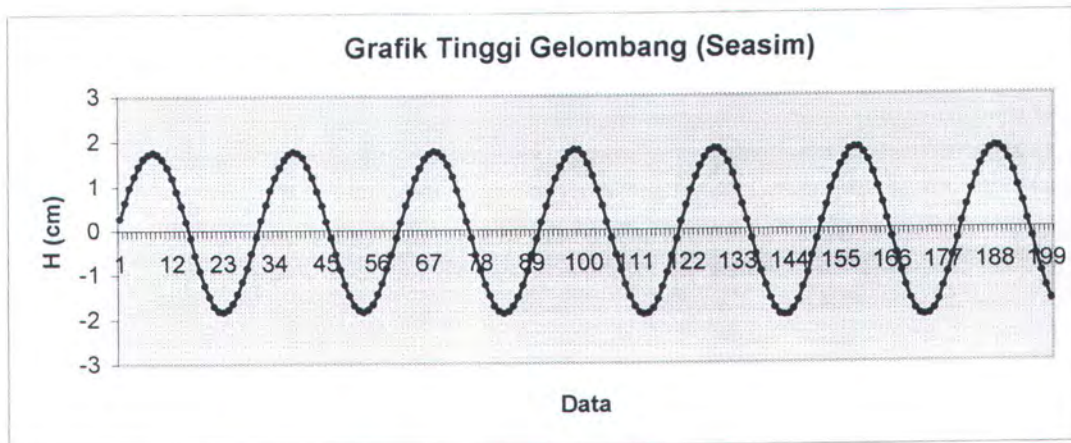
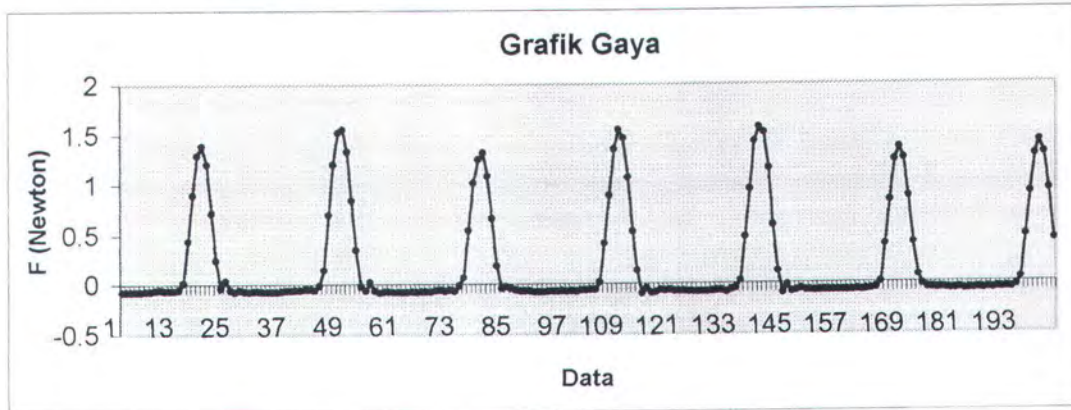



**Grafik Gaya, Simpangan, dan Tinggi Gelombang**  
 Kondisi Sarat 6.5 cm, Tinggi Gel. 4 cm, Periode 1.6 dt

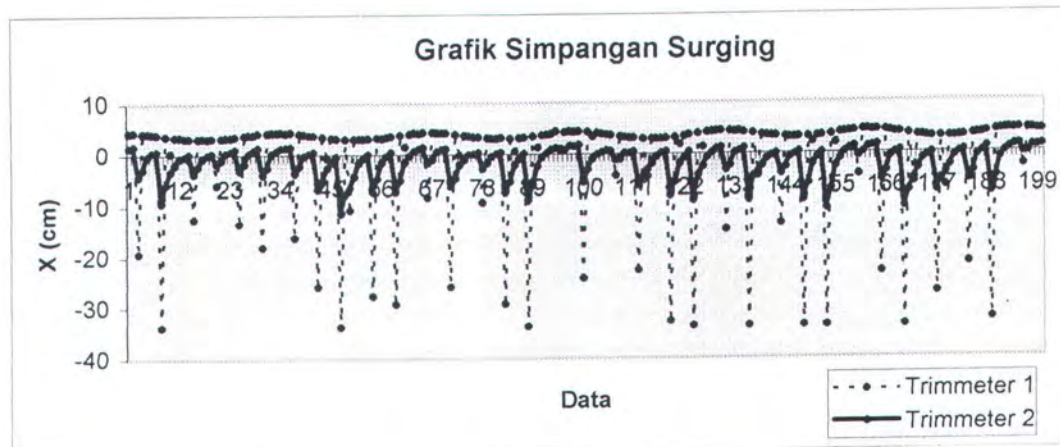
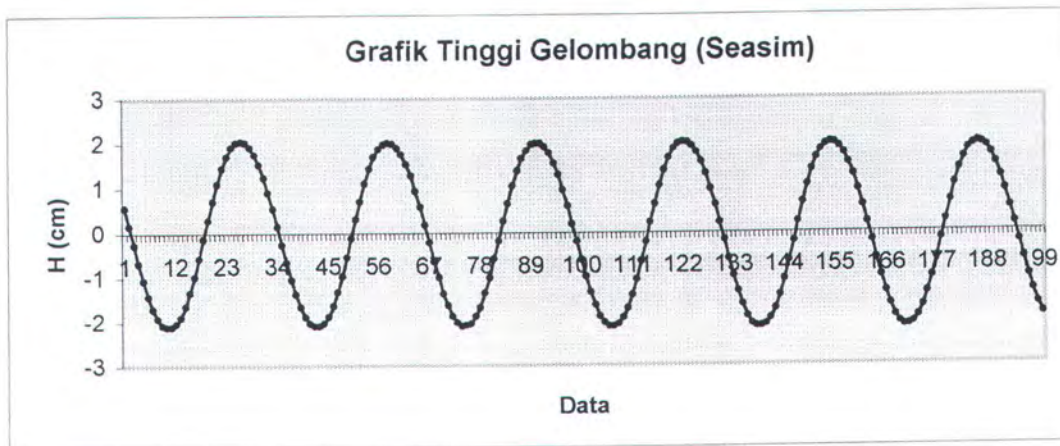
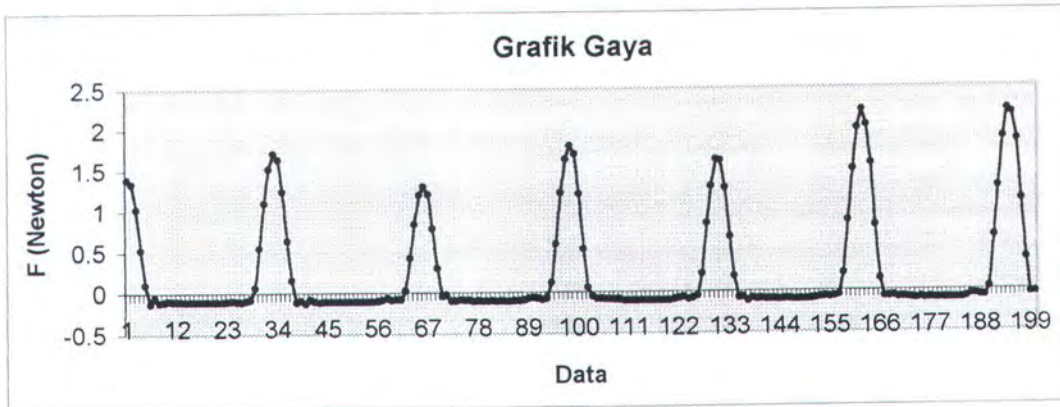



**Grafik Gaya, Simpangan, dan Tinggi Gelombang**  
 Kondisi Sarat 6.5 cm, Tinggi Gel. 4 cm, Periode 1.7 dt

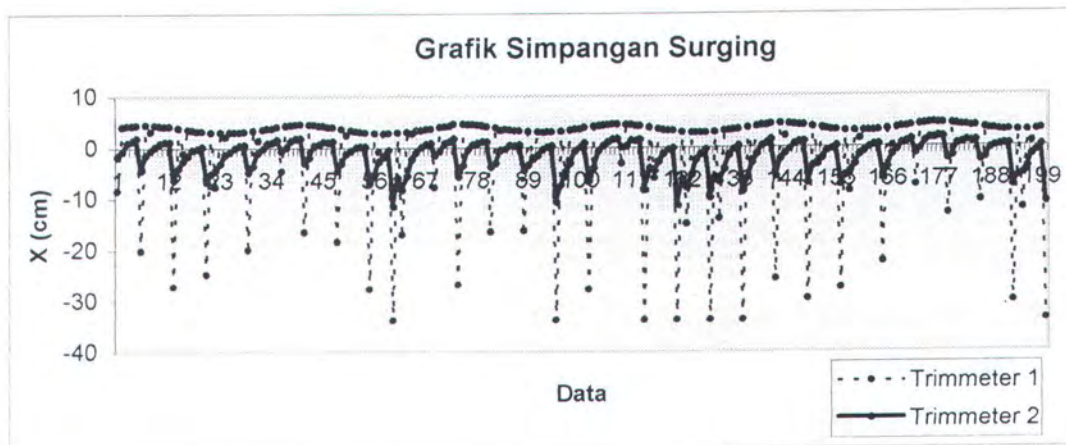
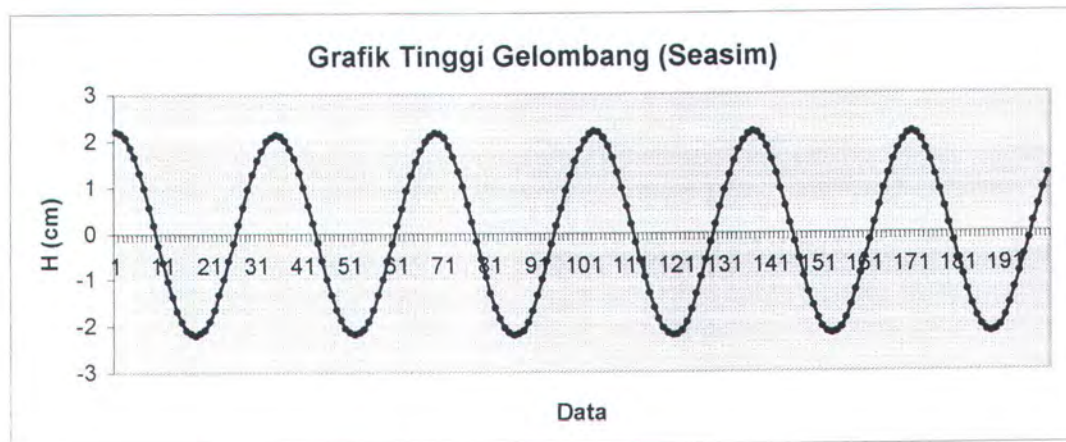
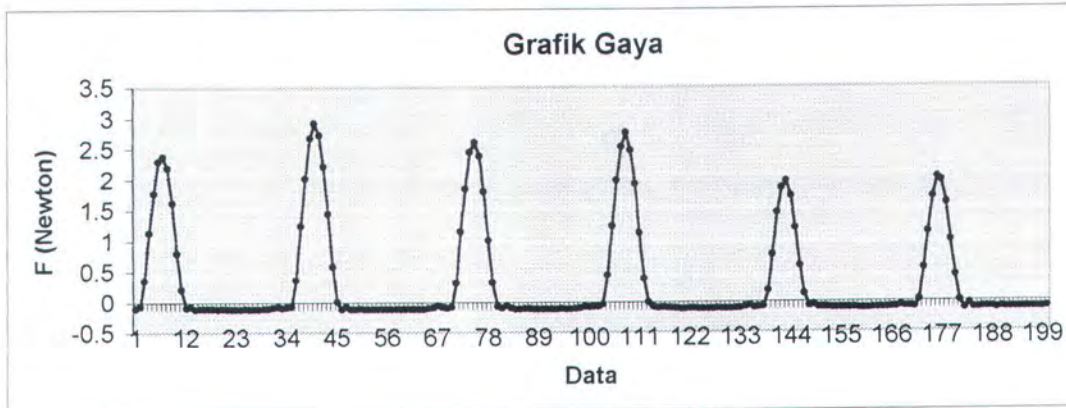



**Grafik Gaya, Simpangan, dan Tinggi Gelombang**  
 Kondisi Sarat 6.5 cm, Tinggi Gel. 4 cm, Periode 1.8 dt

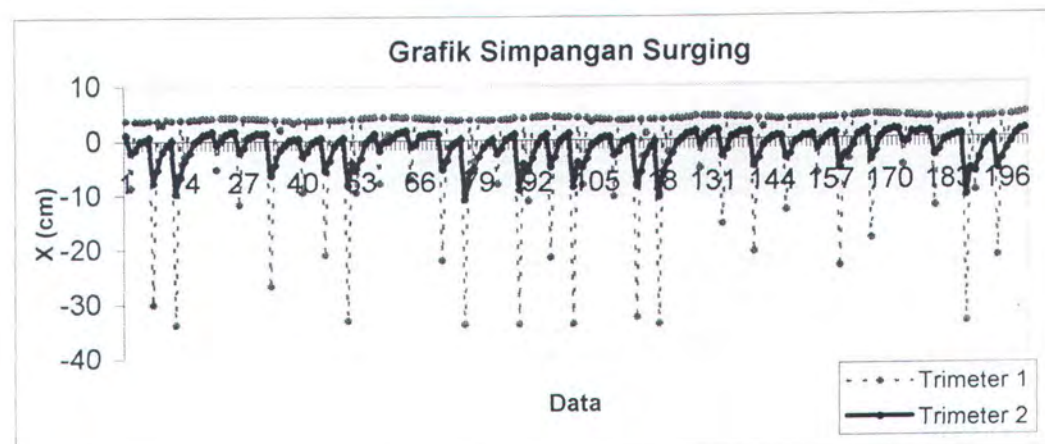
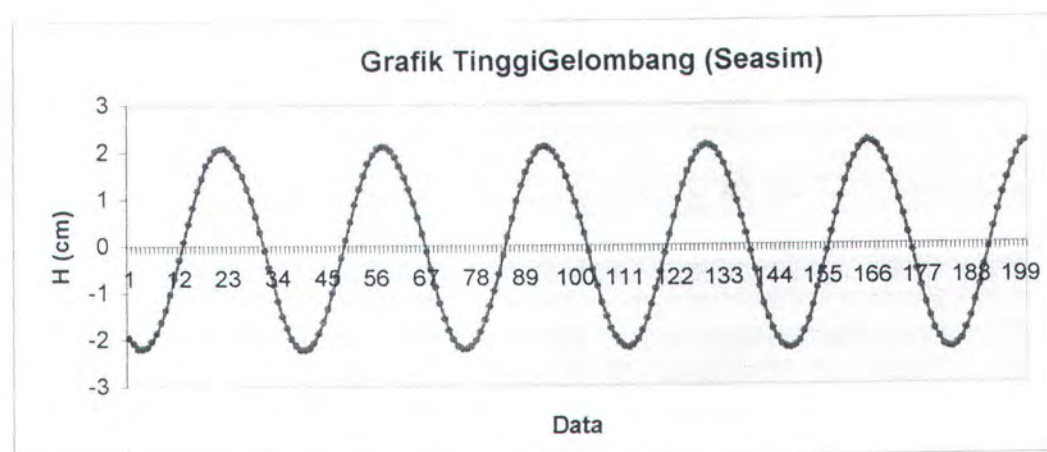
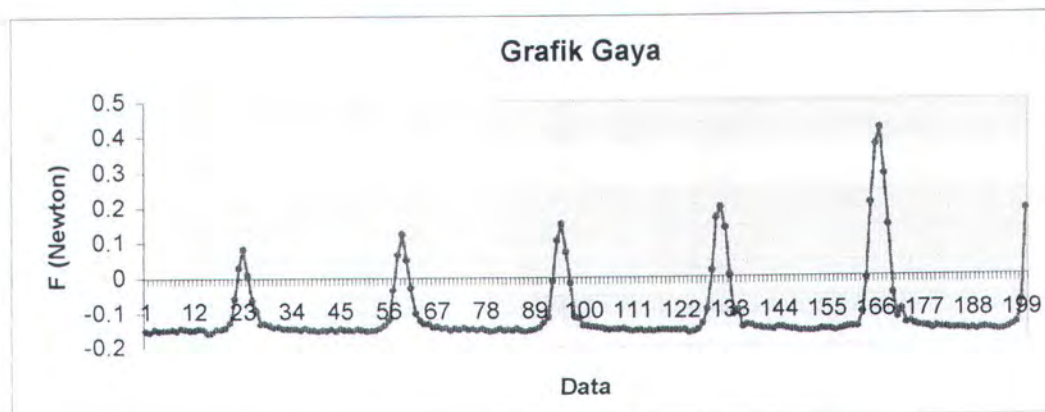



Grafik Gaya, Simpangan, dan Tinggi Gelombang  
Kondisi Sarat 6.5 cm, Tinggi Gel. 4 cm, Periode 1.9 dt

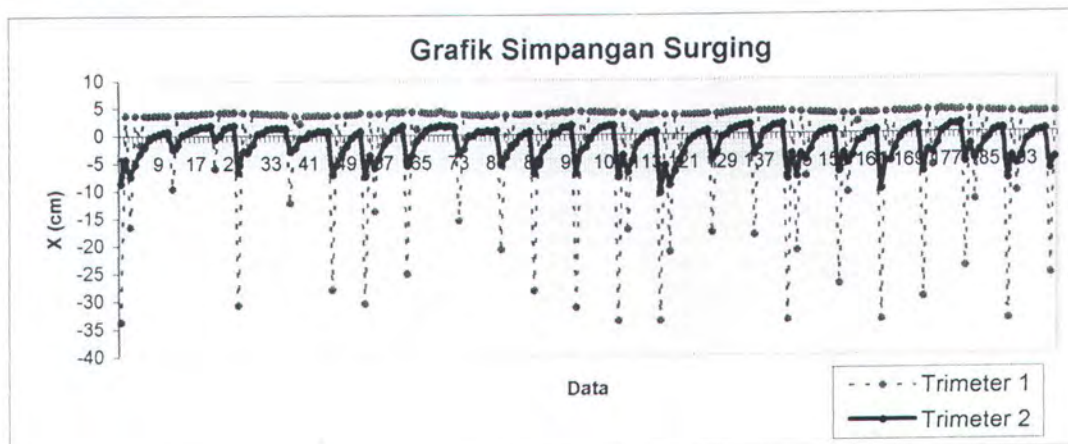
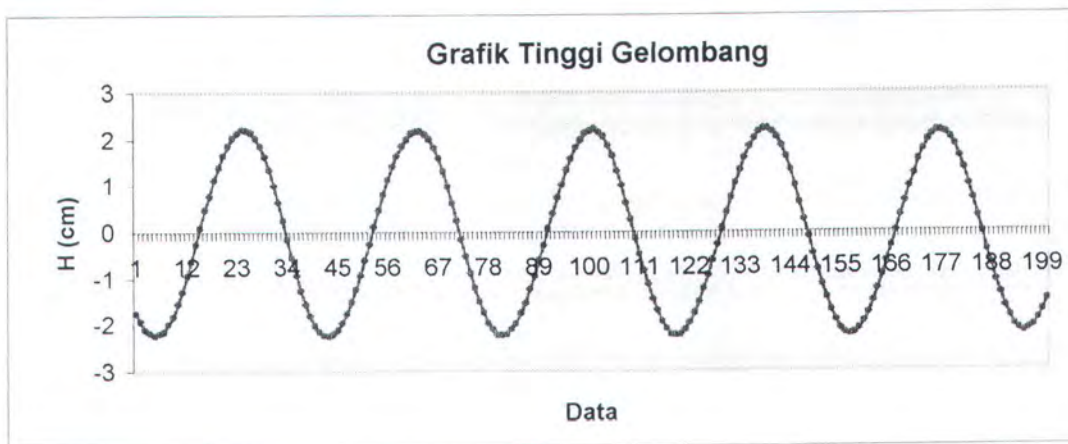
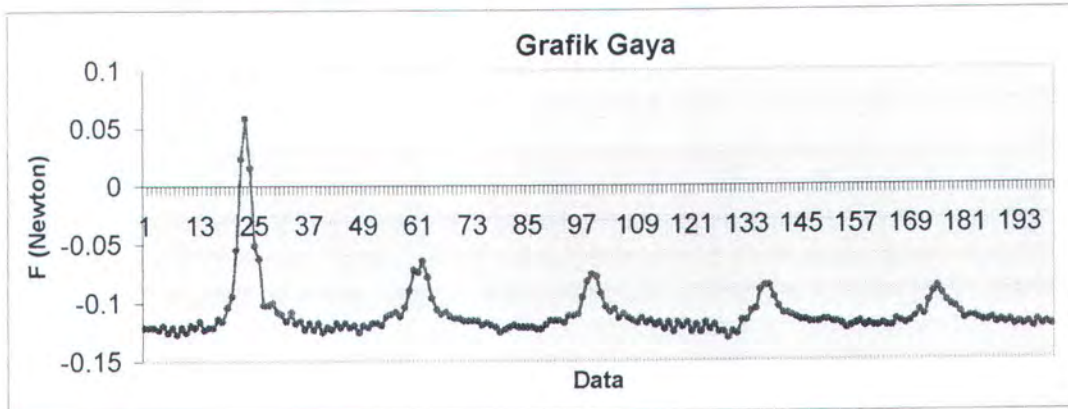



Grafik Gaya, Simpangan, dan Tinggi Gelombang  
Kondisi Sarat 6.5 cm, Tinggi Gel. 4 cm, Periode 2.0 dt

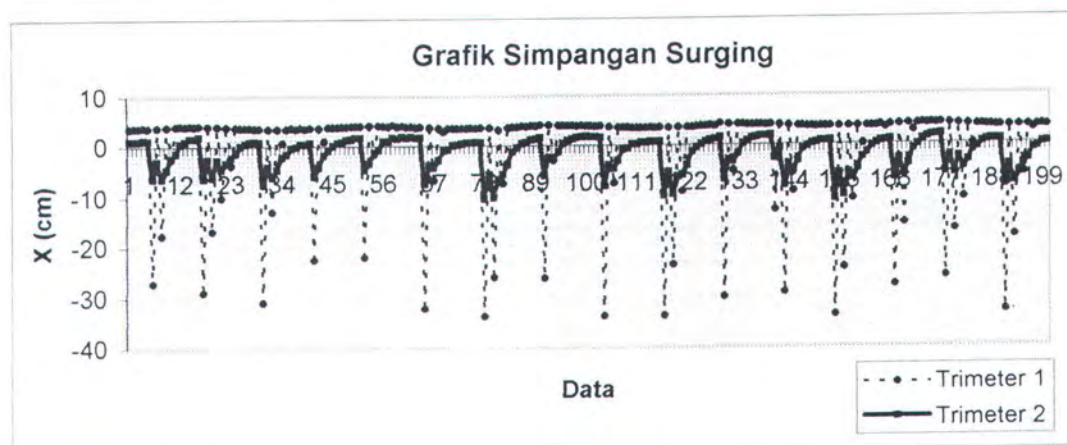
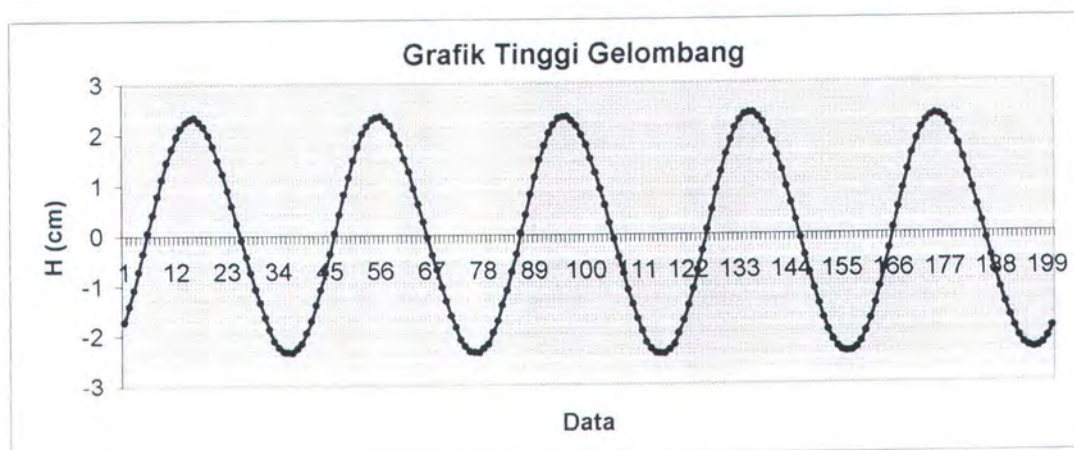
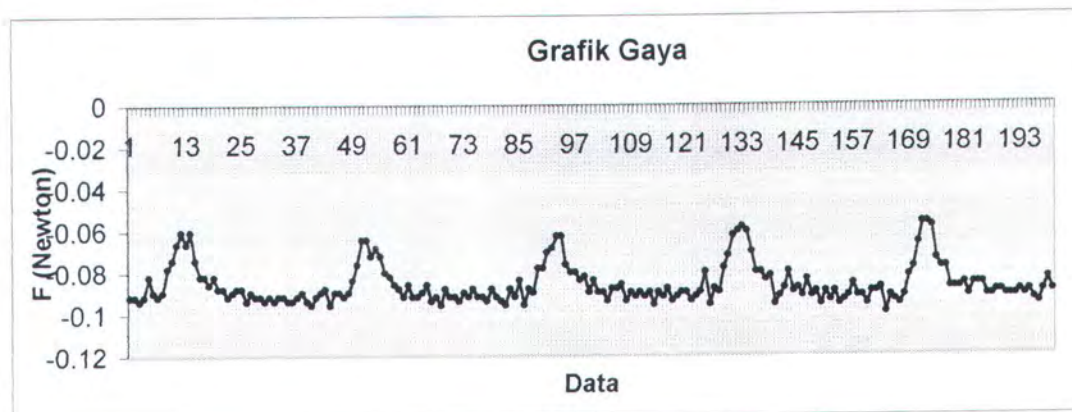



**Grafik Gaya, Simpangan, dan Tinggi Gelombang**  
**Kondisi Sarat 6.5 cm, Tinggi Gel. 2 cm, Periode 1.2 dt**

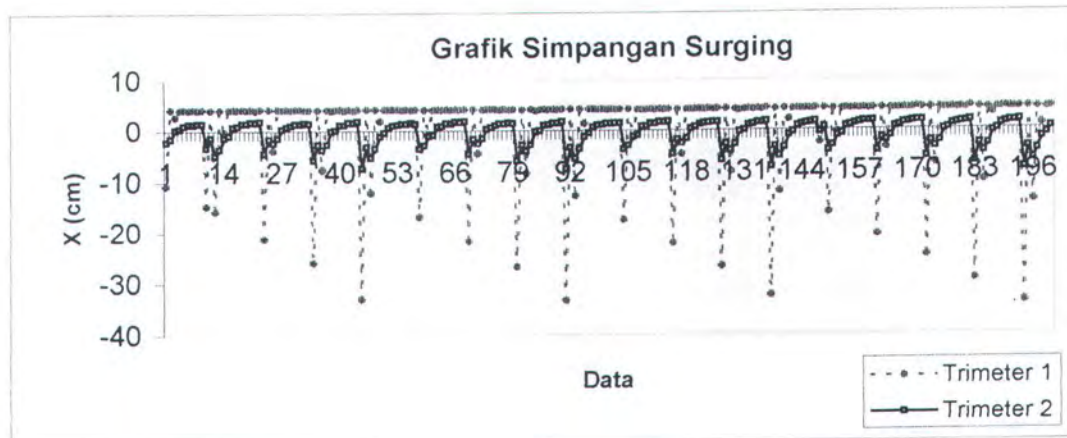
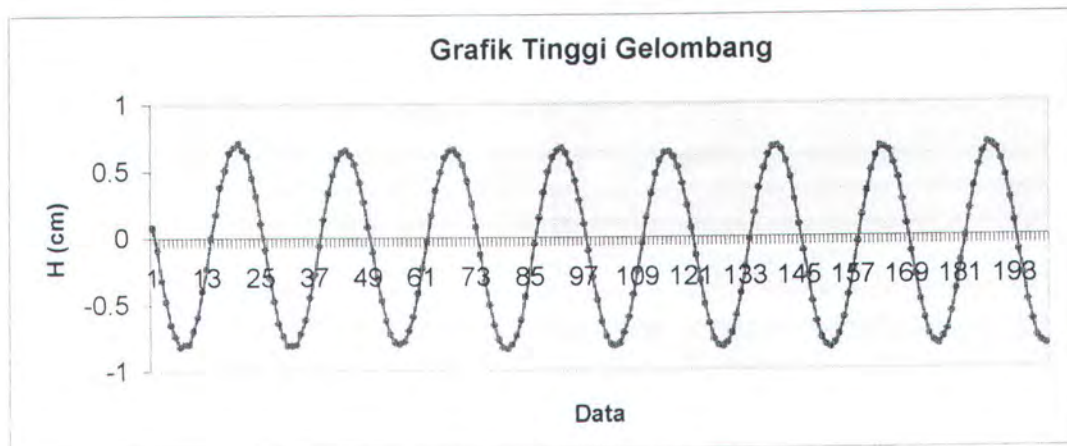
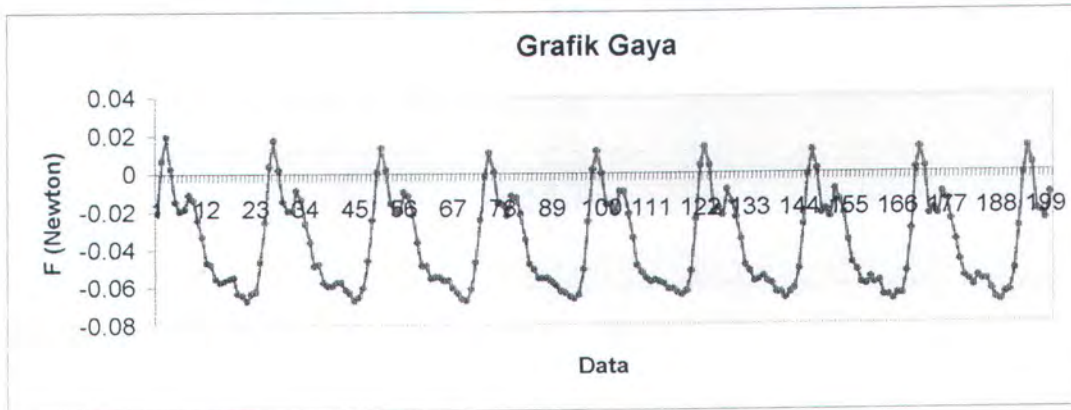



Grafik Gaya, Simpangan, dan Tinggi Gelombang  
Kondisi Sarat 6.5 cm, Tinggi Gel. 2 cm, Periode 1.3 dt

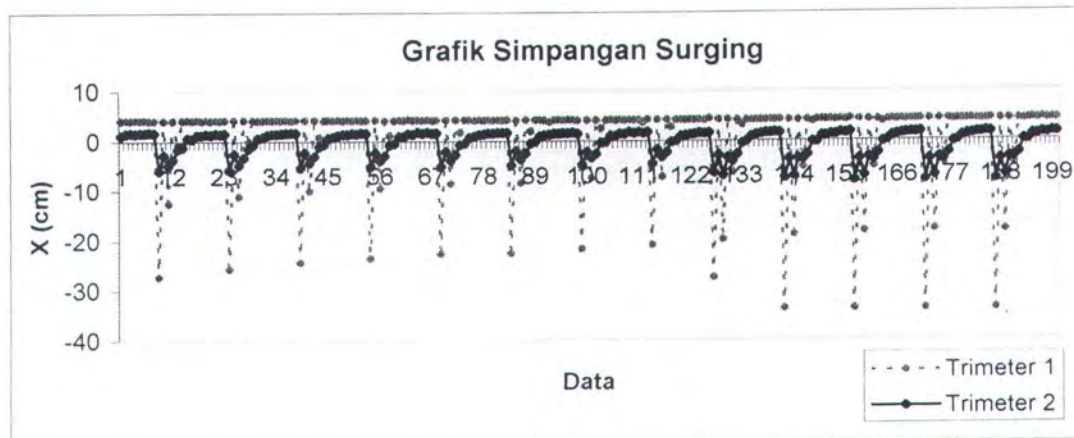
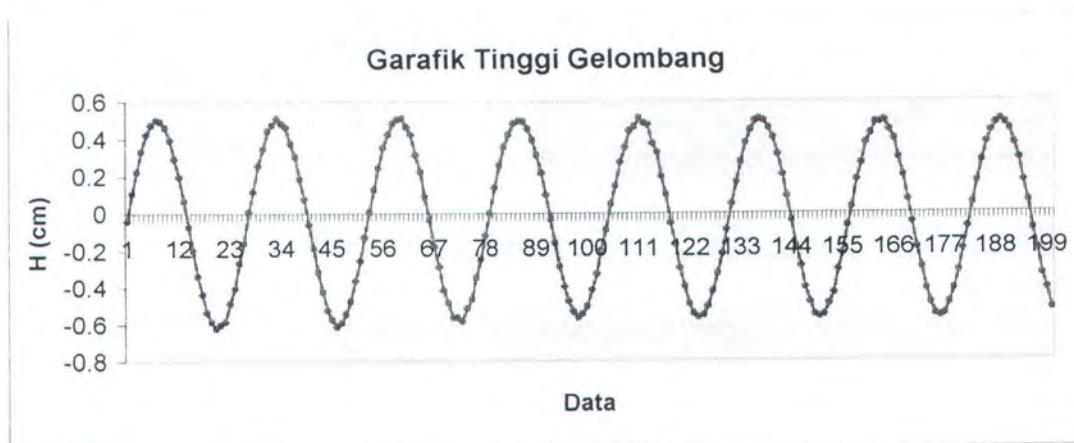
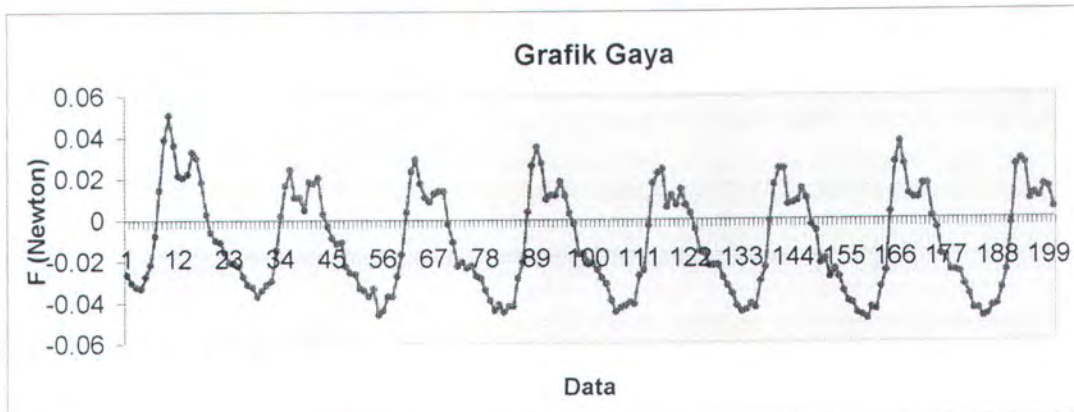



Grafik Gaya, Simpangan, dan Tinggi Gelombang  
Kondisi Sarat 6.5 cm, Tinggi Gel. 2 cm, Periode 1.4 dt

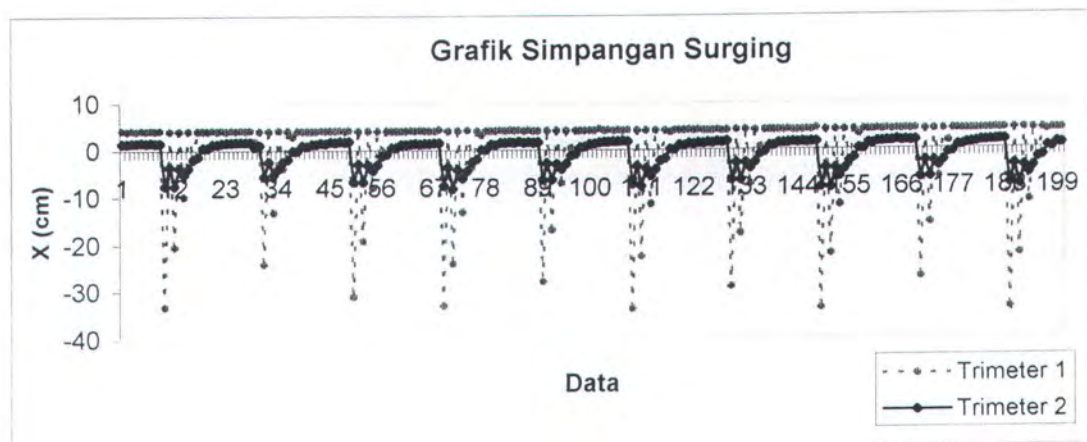
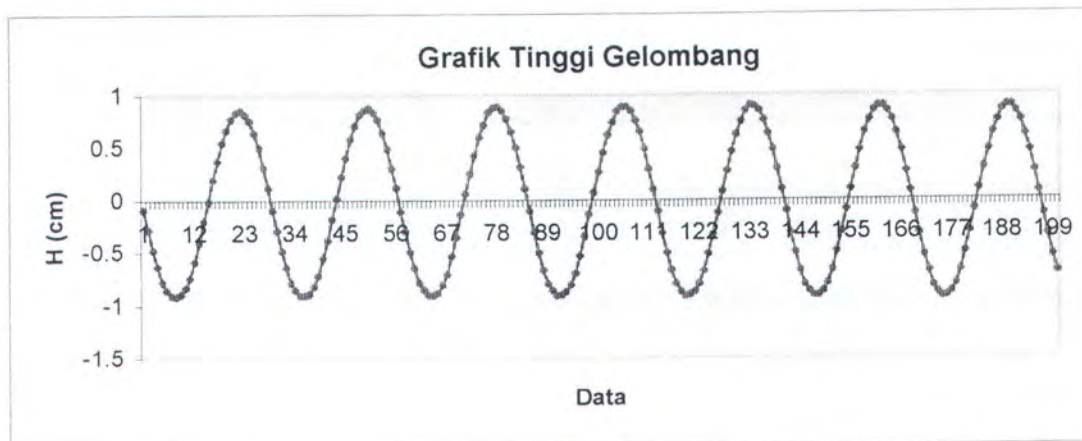
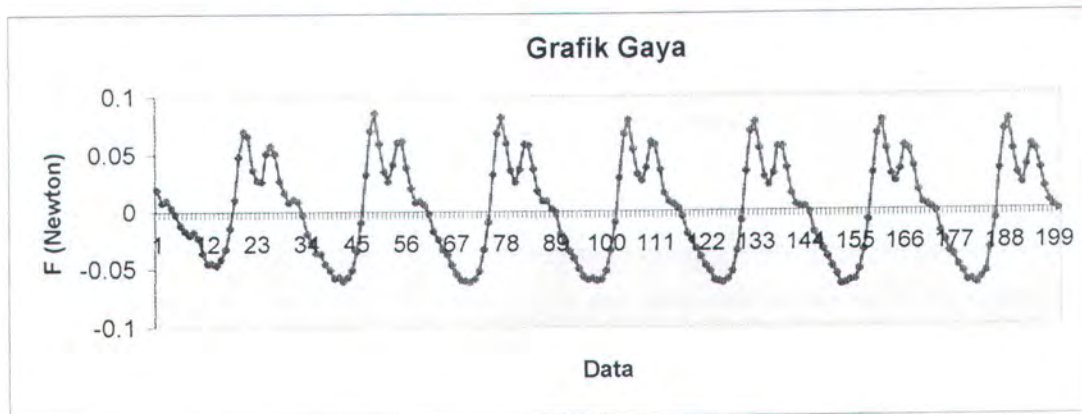



Grafik Gaya, Simpangan, dan Tinggi Gelombang  
Kondisi Sarat 6.5 cm, Tinggi Gel. 2 cm, Periode 1.5 dt

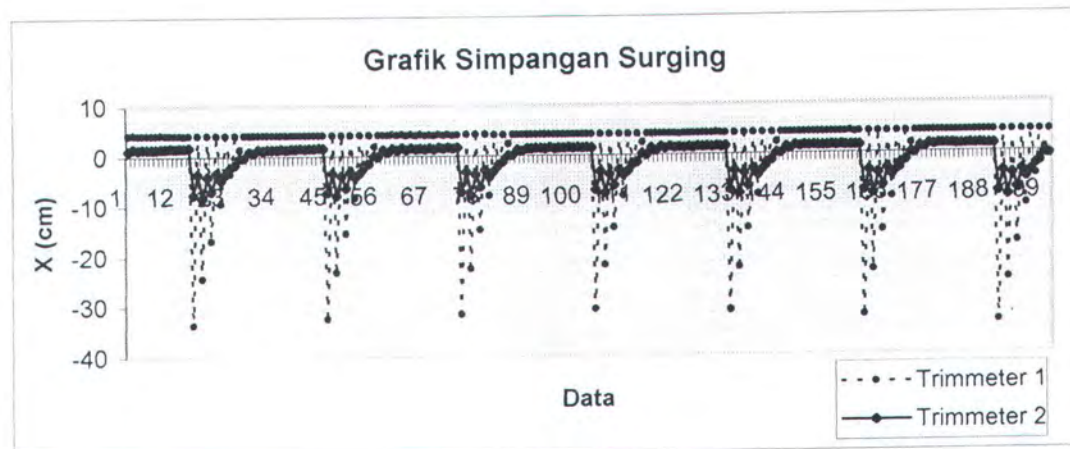
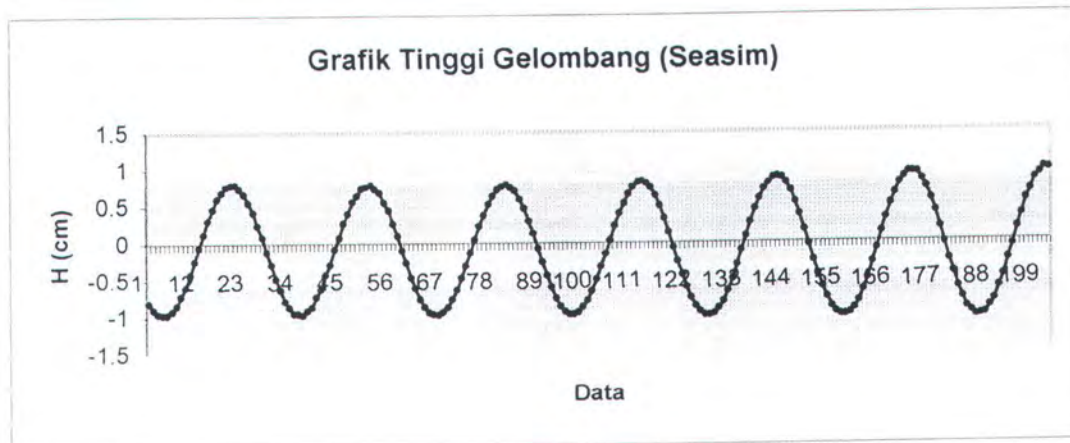
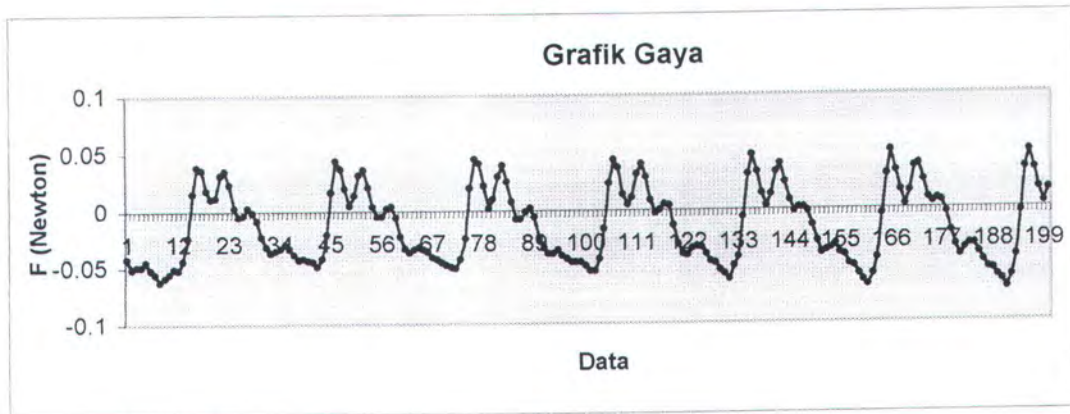



**Grafik Gaya, Simpangan, dan Tinggi Gelombang**  
 Kondisi Sarat 6.5 cm, Tinggi Gel. 2 cm, Periode 1.6 dt

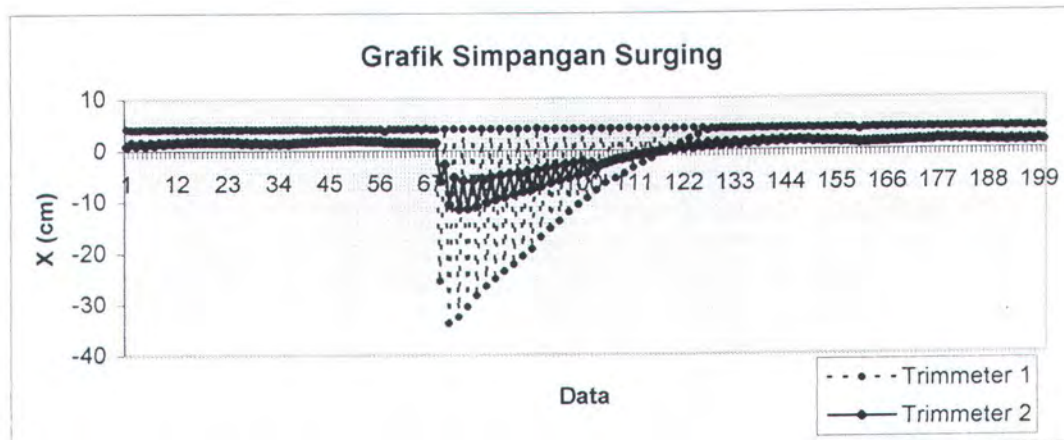
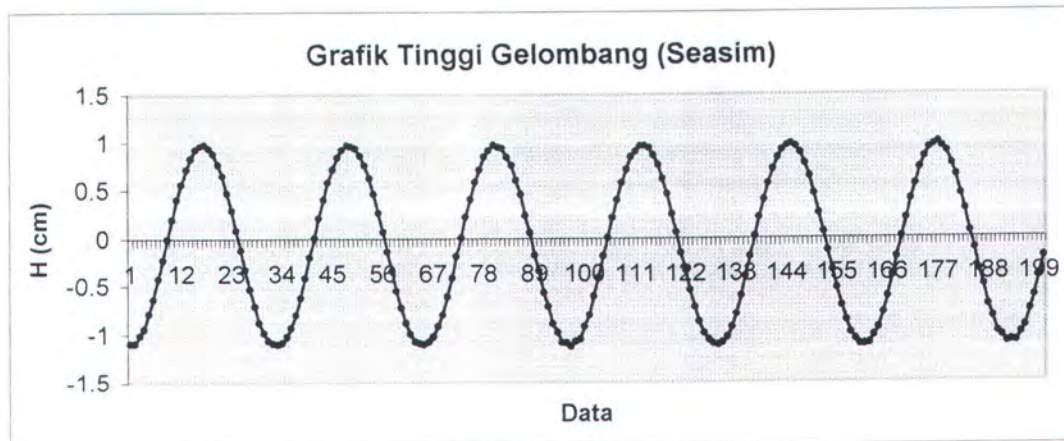
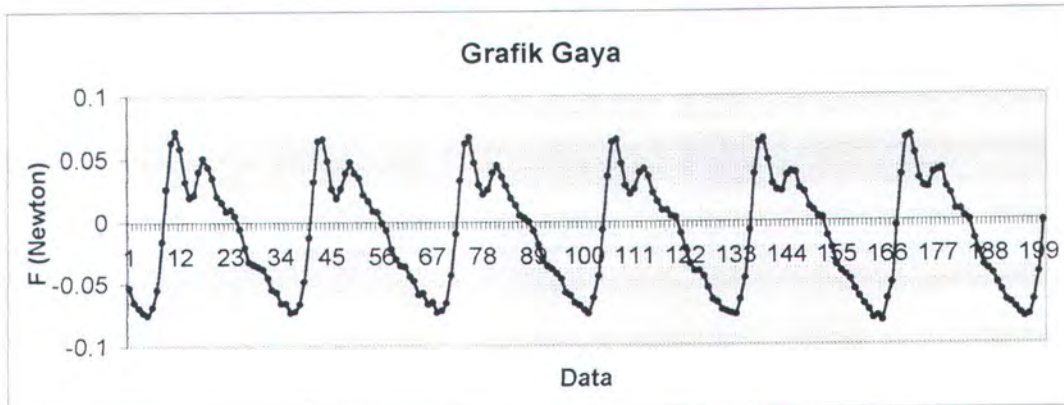



Grafik Gaya, Simpangan, dan Tinggi Gelombang  
Kondisi Sarat 6.5 cm, Tinggi Gel. 2 cm, Periode 1.7 dt

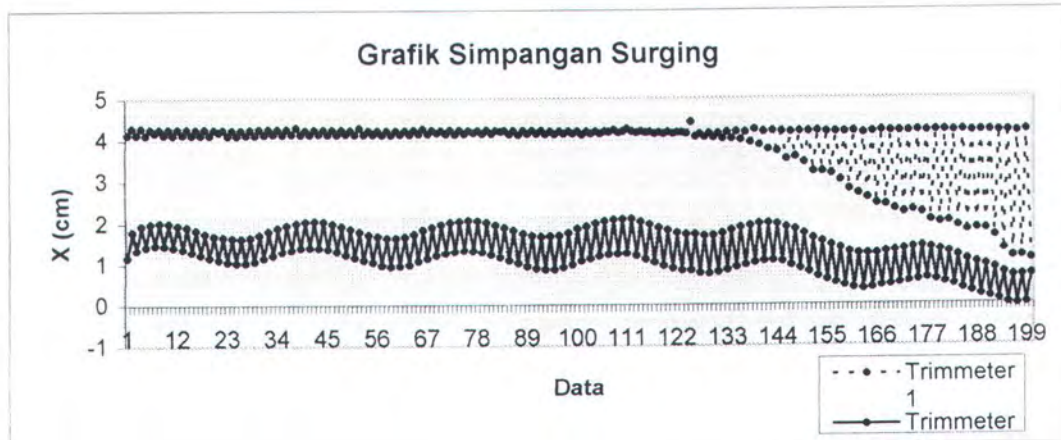
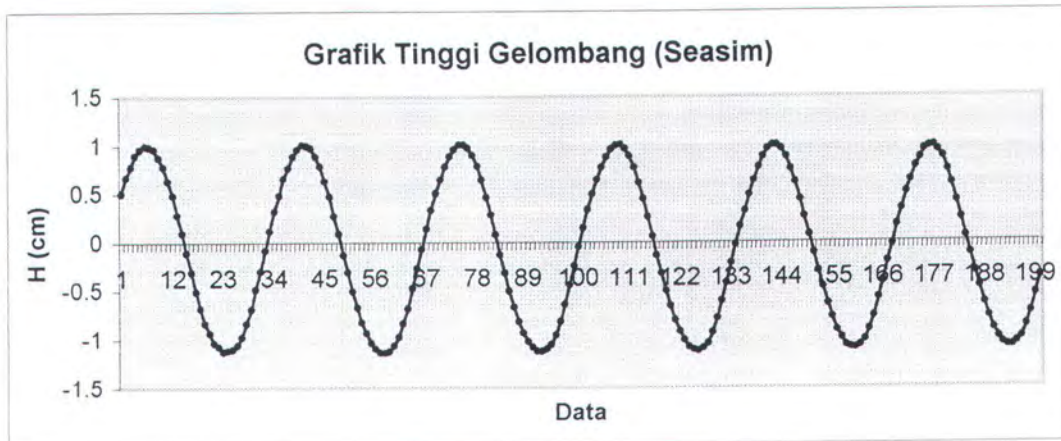
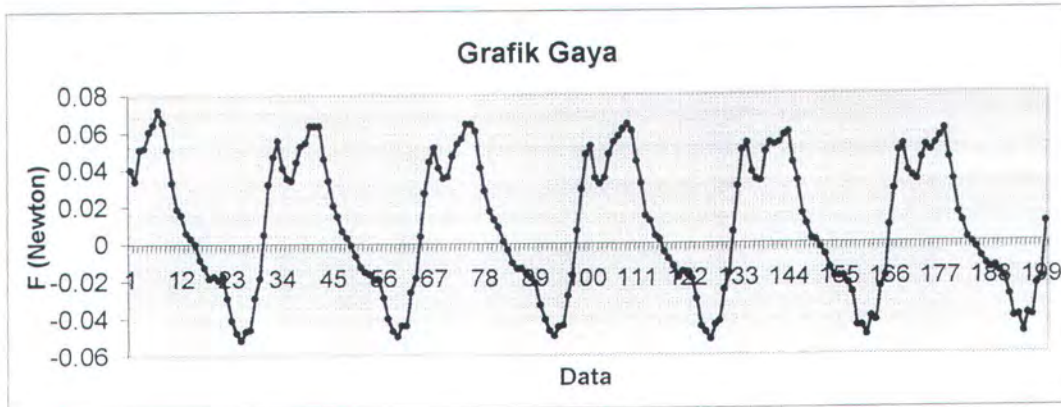



**Grafik Gaya, Simpangan, dan Tinggi Gelombang**  
 Kondisi Sarat 6.5 cm, Tinggi Gel. 2 cm, Periode 1.8 dt

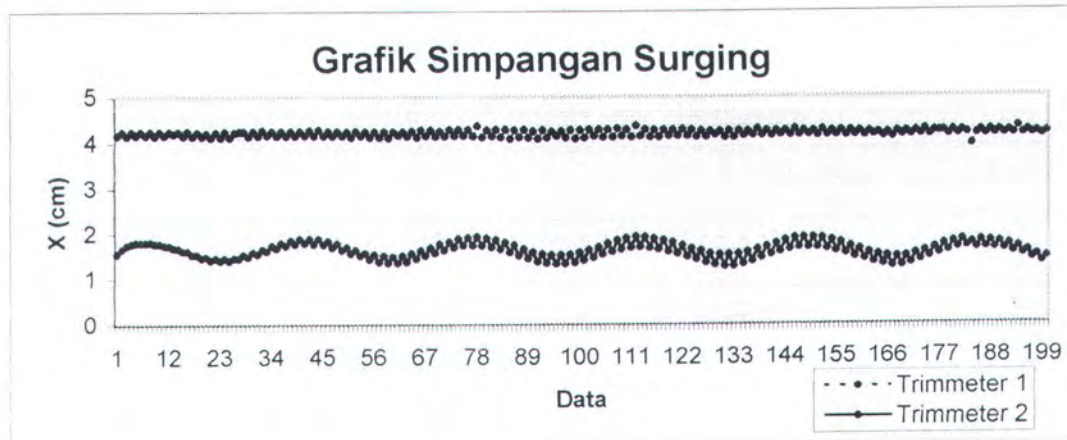
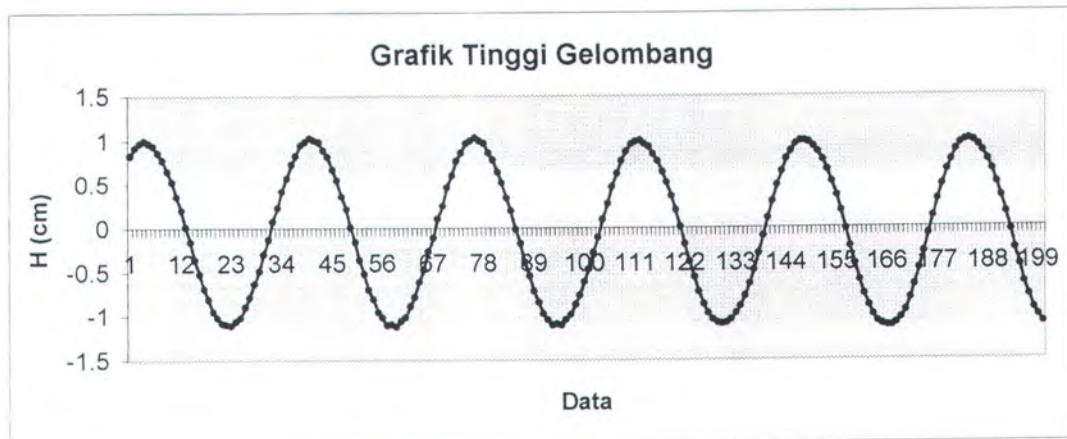
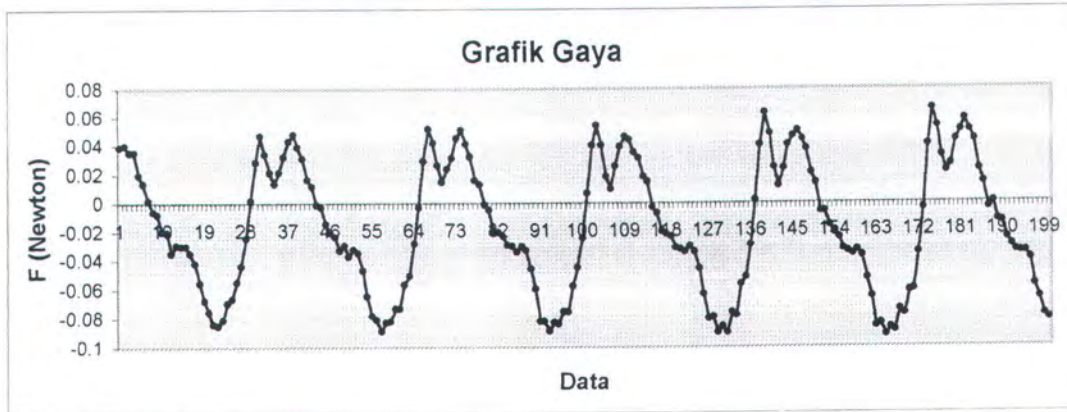



**Grafik Gaya, Simpangan, dan Tinggi Gelombang**  
 Kondisi Sarat 6.5 cm, Tinggi Gel. 2 cm, Periode 1.9 dt

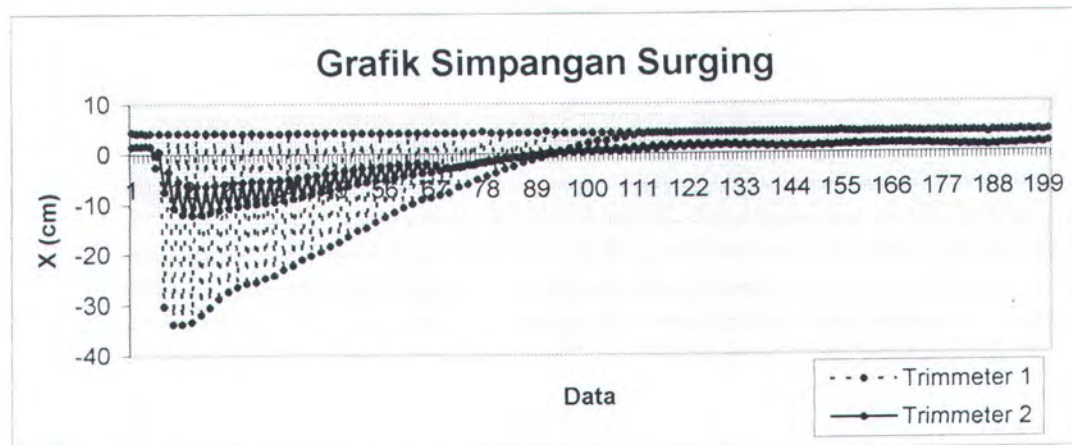
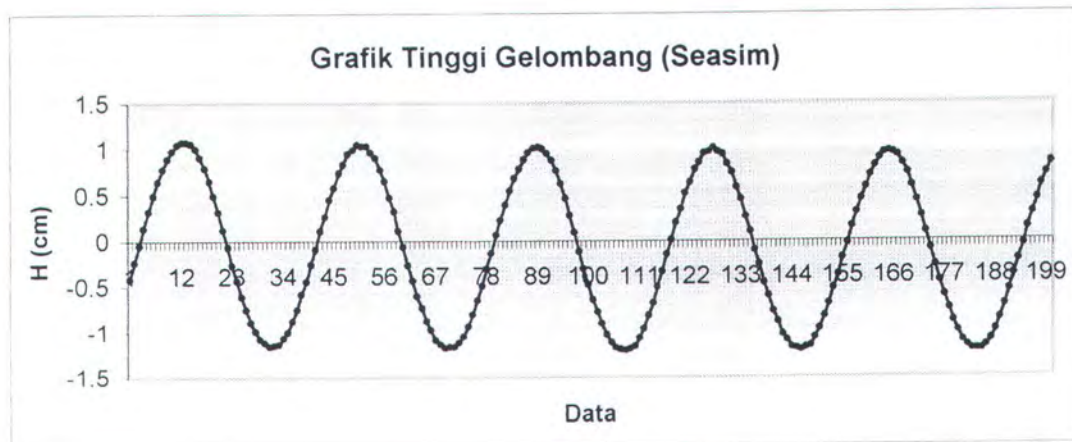
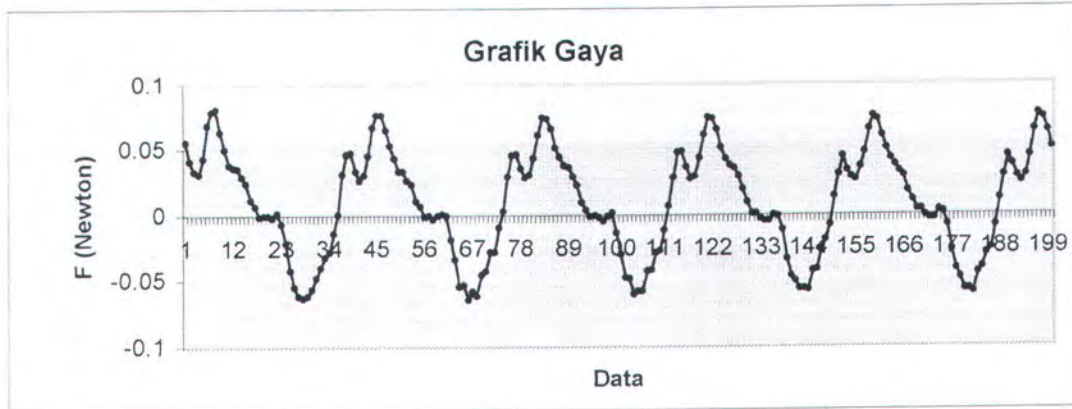



**Grafik Gaya, Simpangan, dan Tinggi Gelombang**  
 Kondisi Sarat 6.5 cm, Tinggi Gel. 2 cm, Periode 2.0 dt

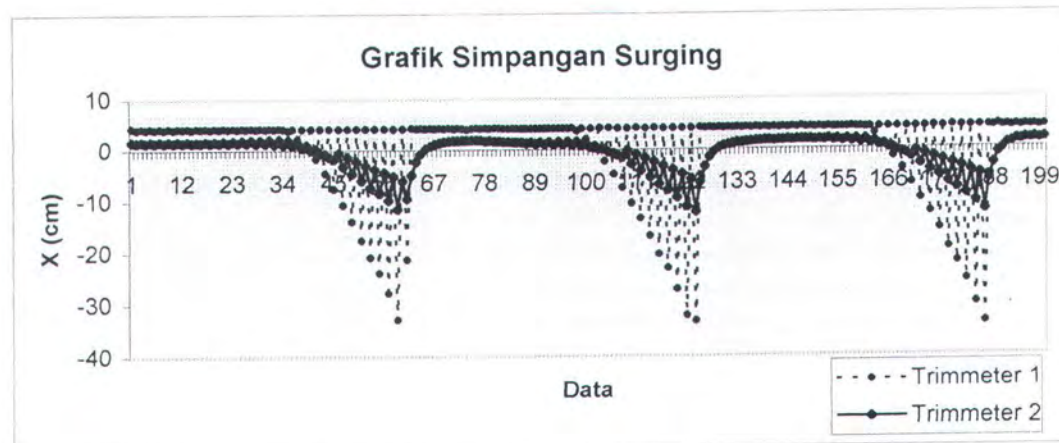
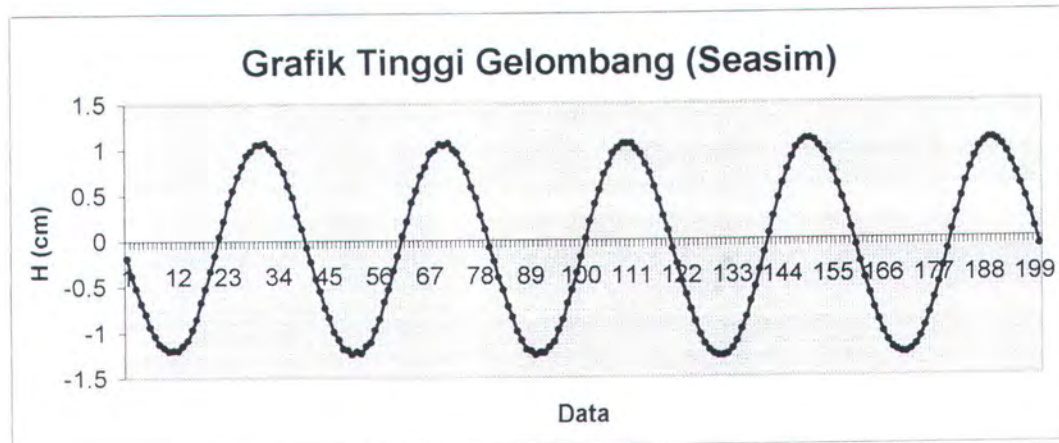
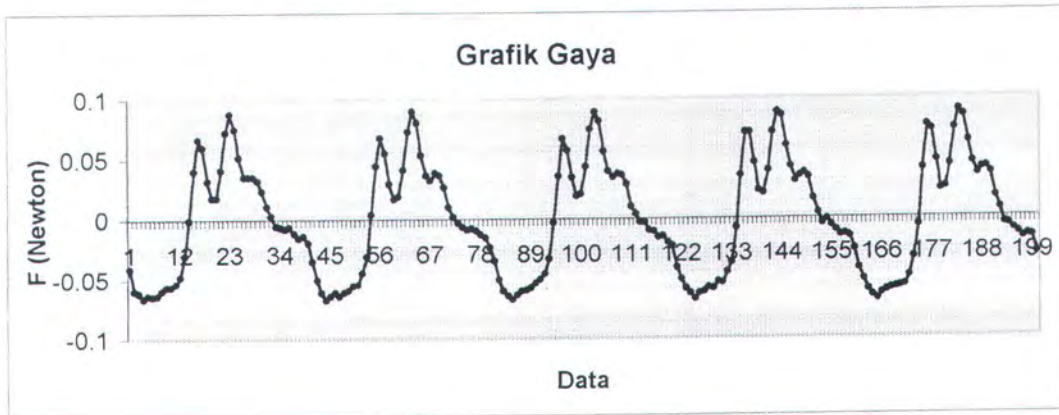



**Grafik Gaya, Simpangan, dan Tinggi Gelombang**  
 Kondisi Sarat 22.4 cm, Tinggi Gel. 4 cm, Periode 1.2 dt

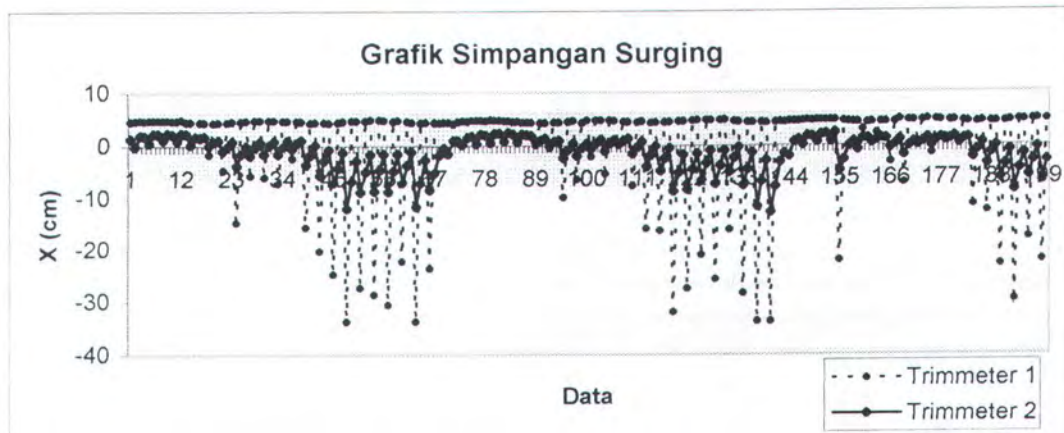
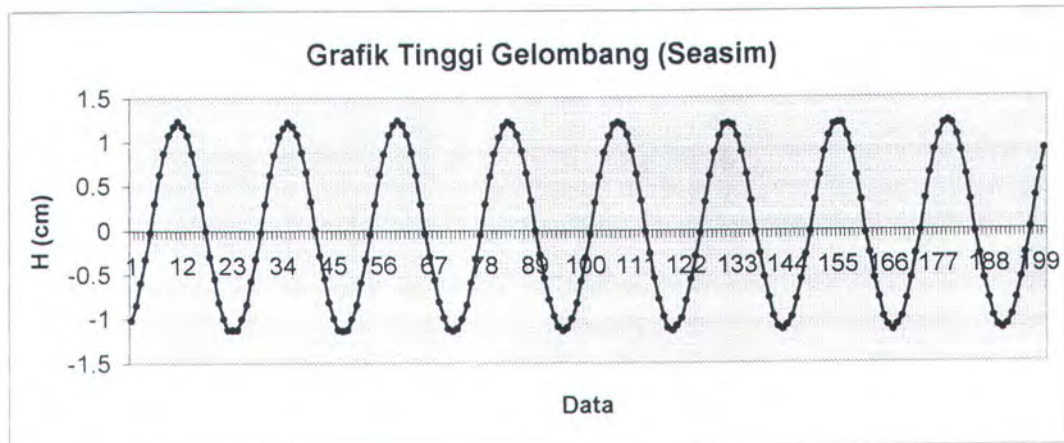
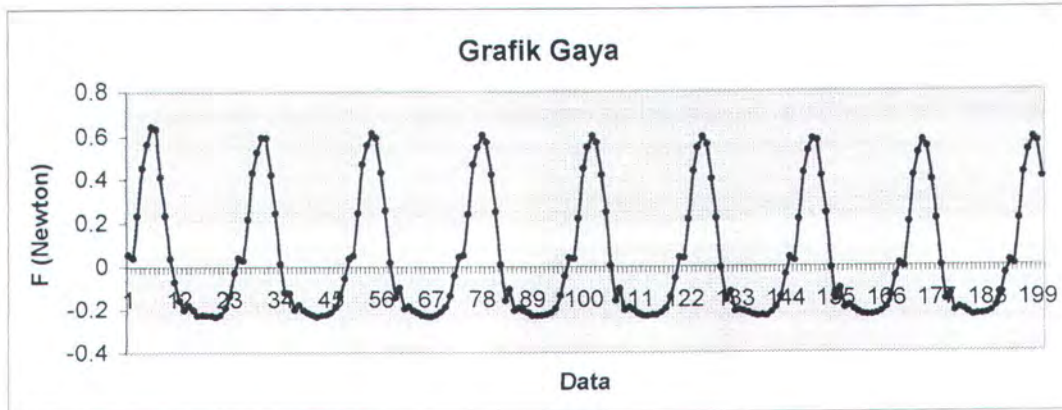



Grafik Gaya, Simpangan, dan Tinggi Gelombang  
Kondisi Sarat 22.4 cm, Tinggi Gel. 4 cm, Periode 1.3 dt

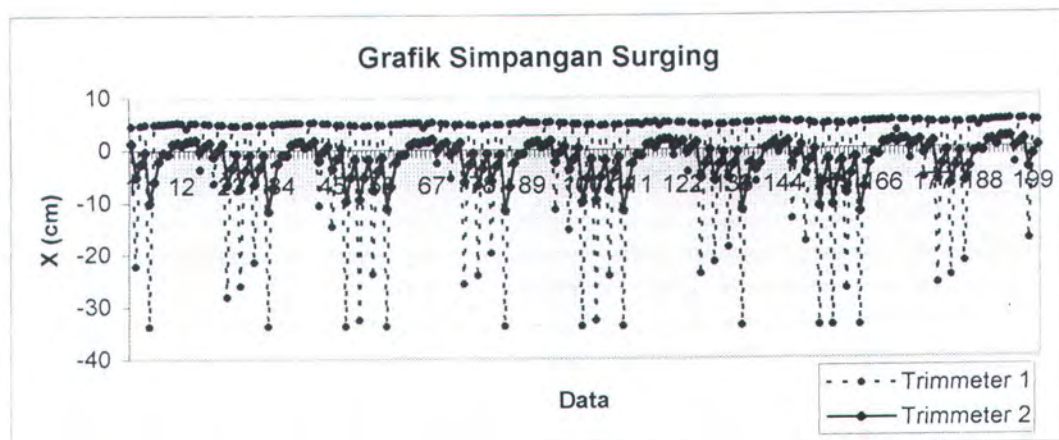
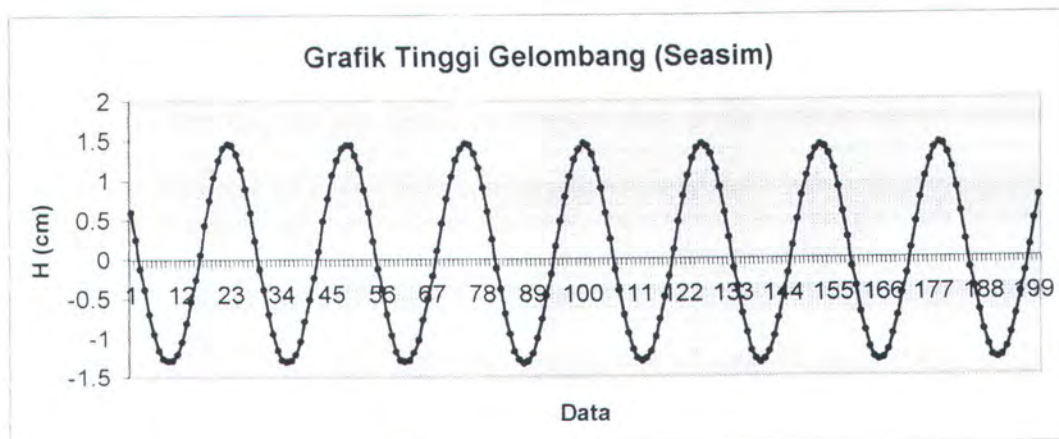
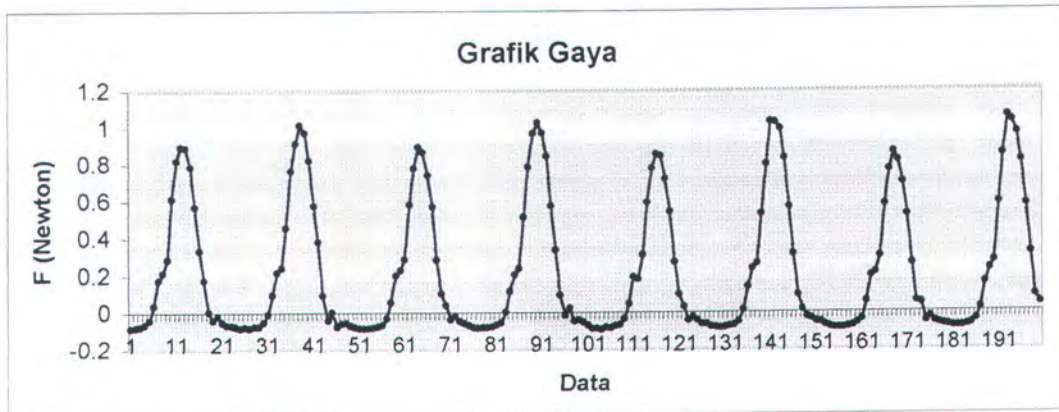



**Grafik Gaya, Simpangan, dan Tinggi Gelombang**  
 Kondisi Sarat 22.4 cm, Tinggi Gel. 4 cm, Periode 1.4 dt

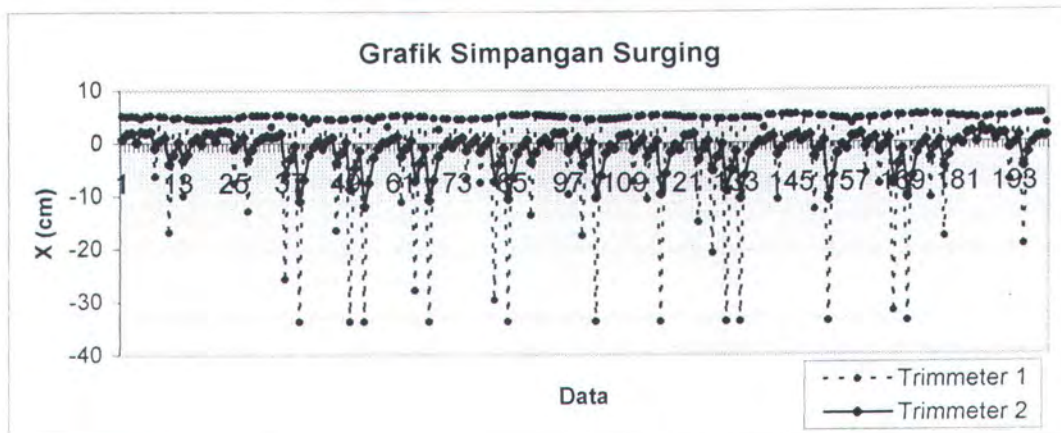
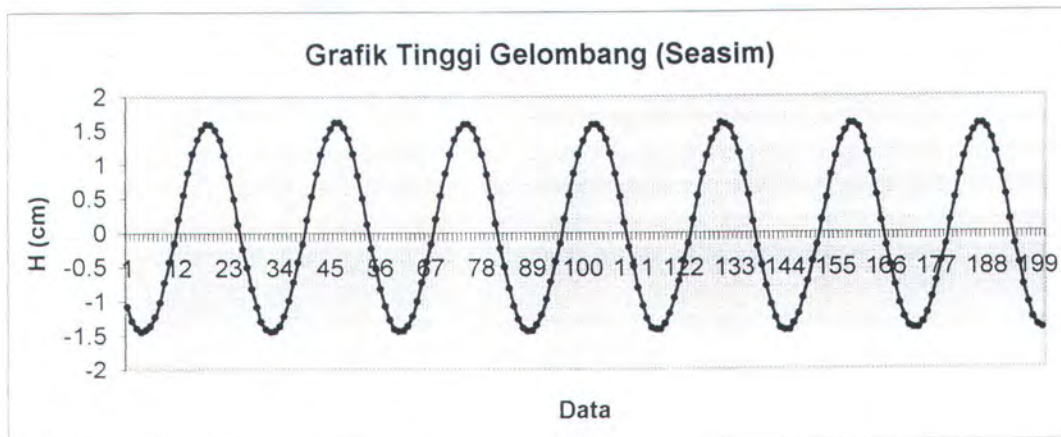
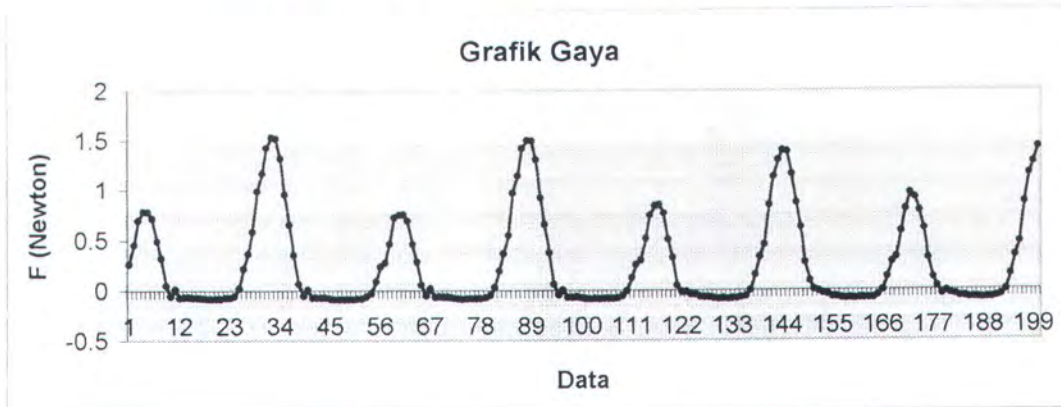



**Grafik Gaya, Simpangan, dan Tinggi Gelombang**  
 Kondisi Sarat 22.4 cm, Tinggi Gel. 4 cm, Periode 1.5 dt

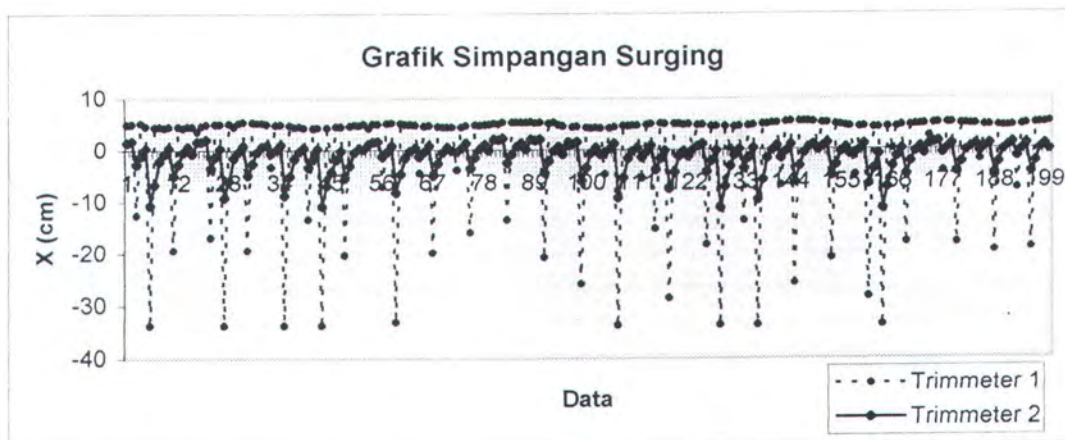
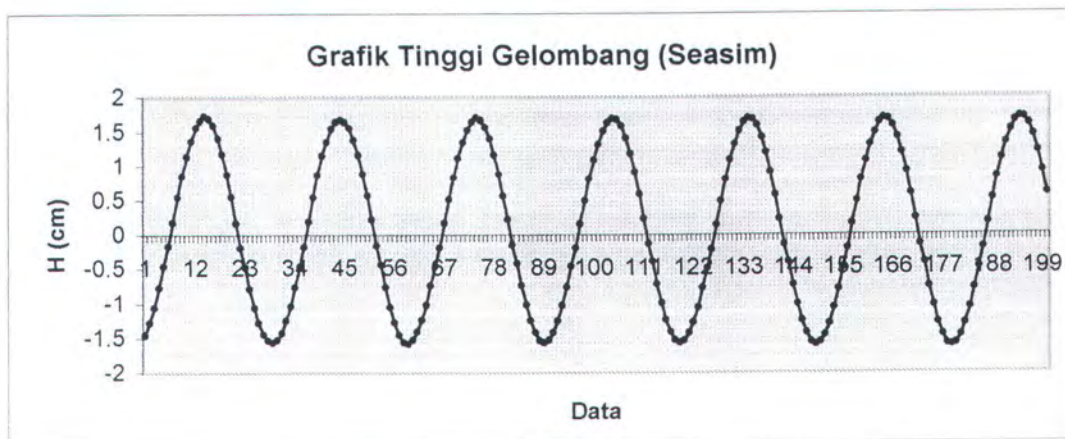
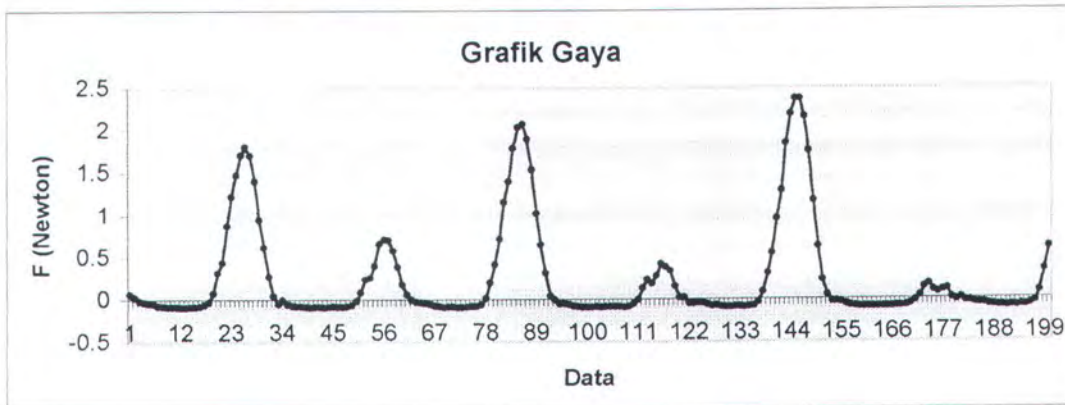



**Grafik Gaya, Simpangan, dan Tinggi Gelombang**  
 Kondisi Sarat 22.4 cm, Tinggi Gel. 4 cm, Periode 1.6 dt

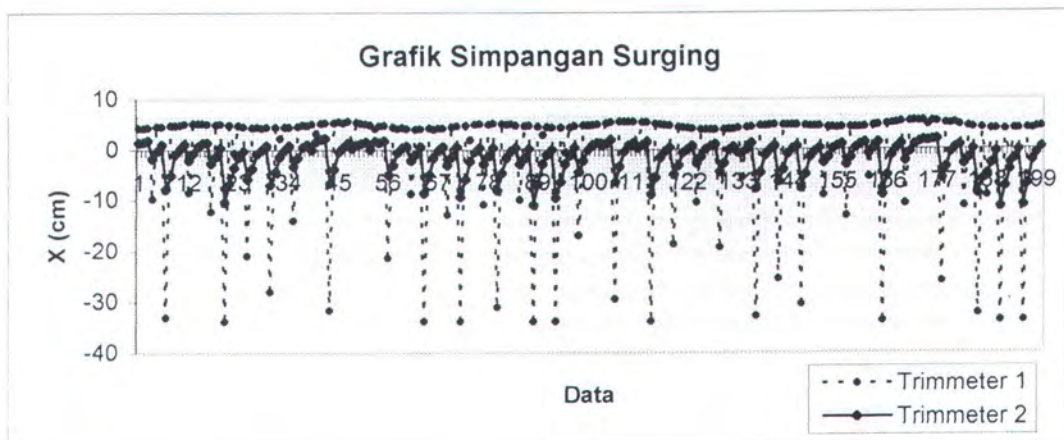
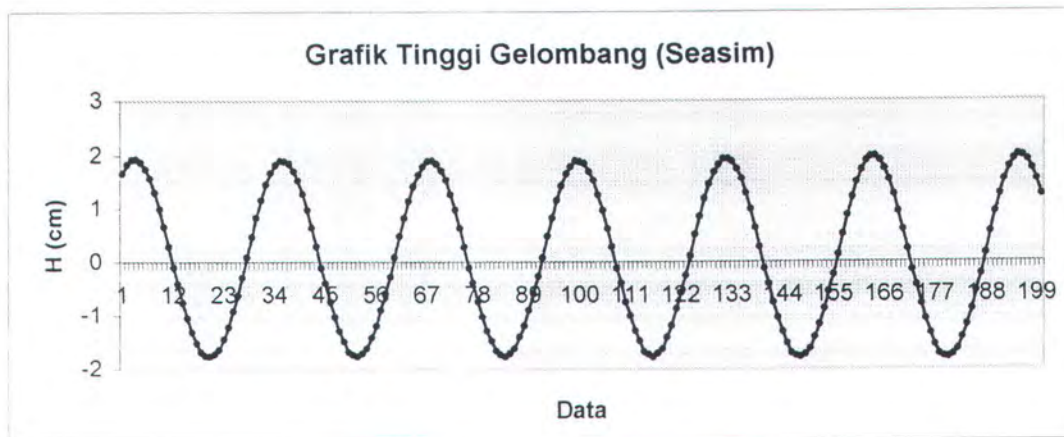
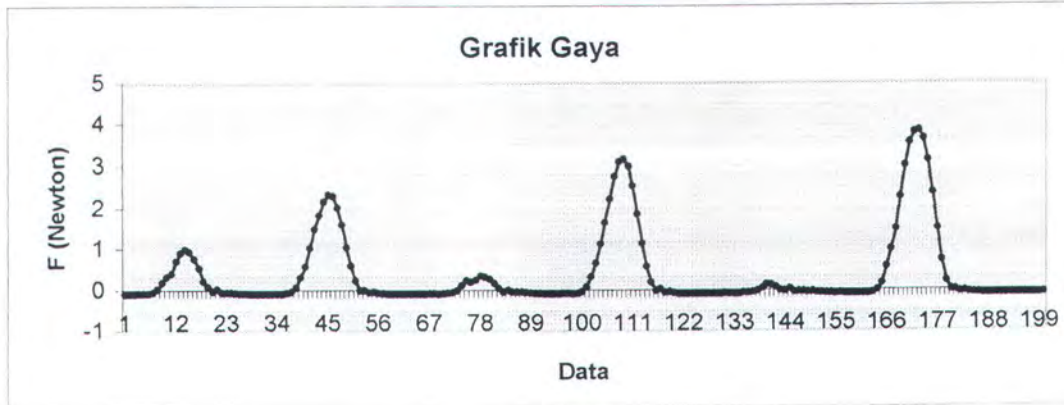



Grafik Gaya, Simpangan, dan Tinggi Gelombang  
Kondisi Sarat 22.4 cm, Tinggi Gel. 4 cm, Periode 1.7 dt

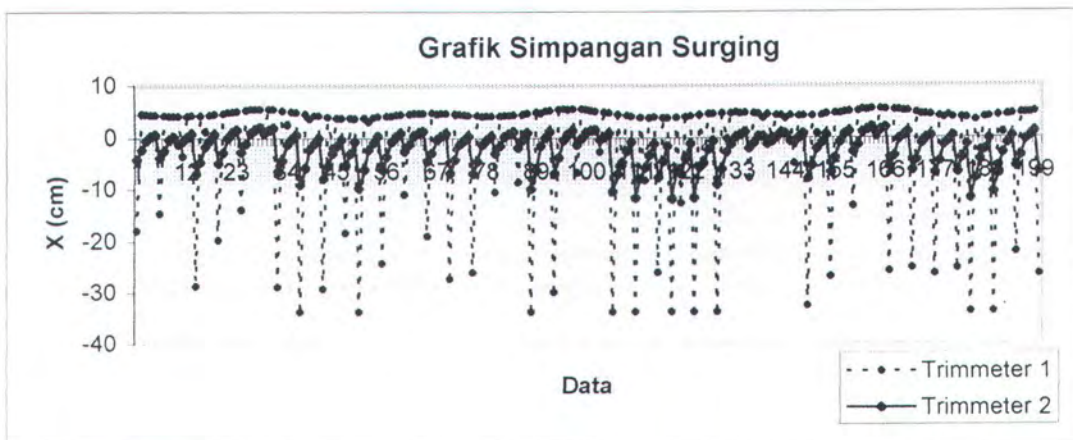
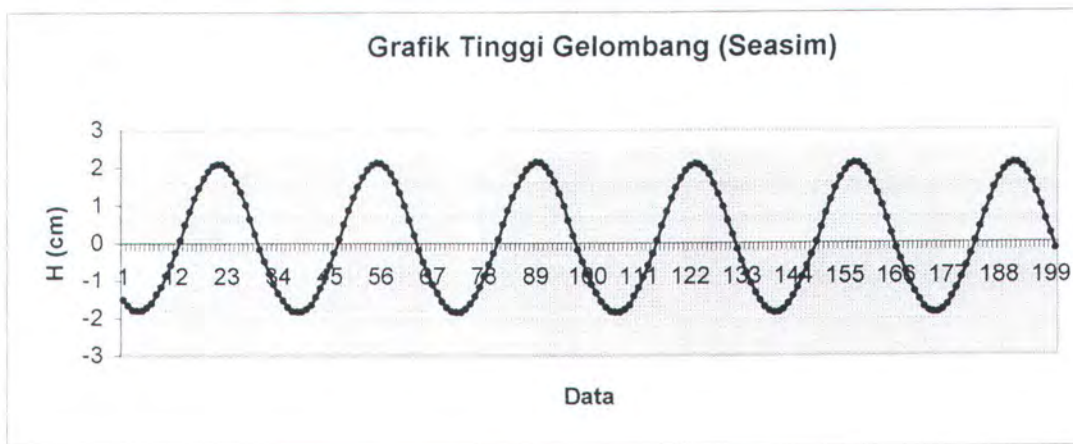
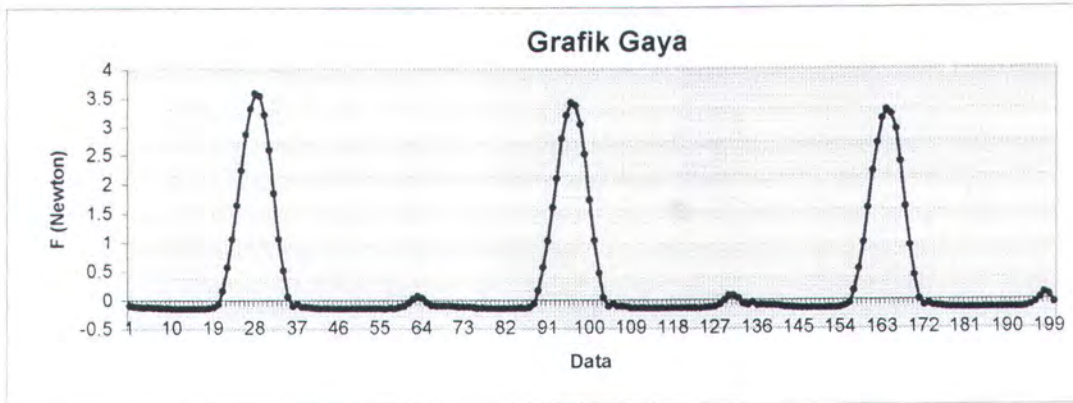



**Grafik Gaya, Simpangan, dan Tinggi Gelombang**  
 Kondisi Sarat 22.4 cm, Tinggi Gel. 4 cm, Periode 1.8 dt

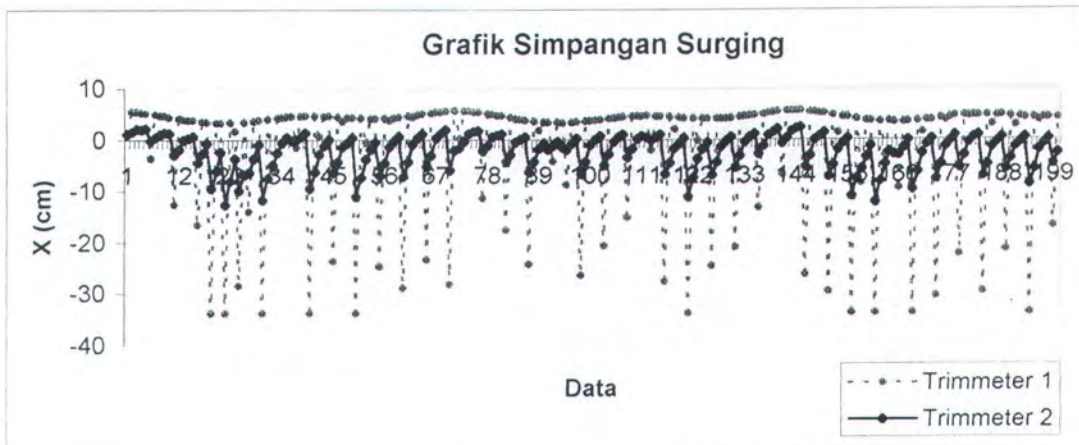
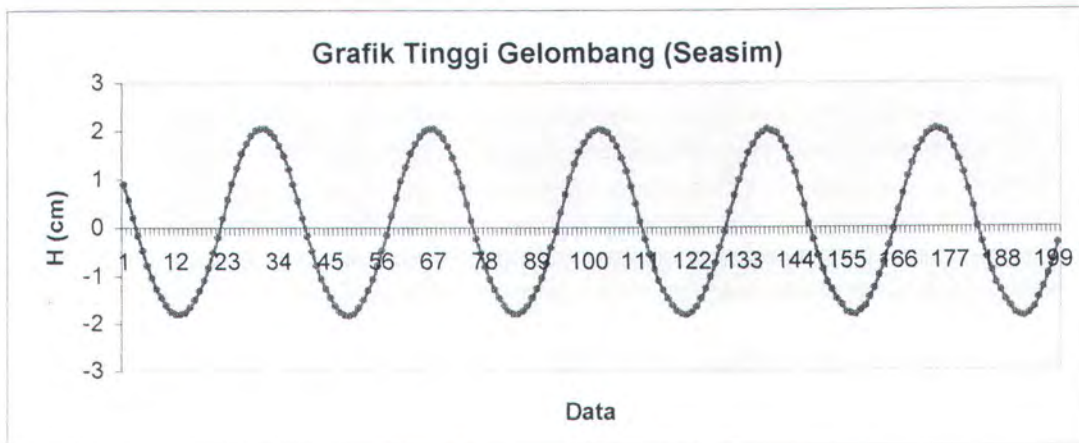
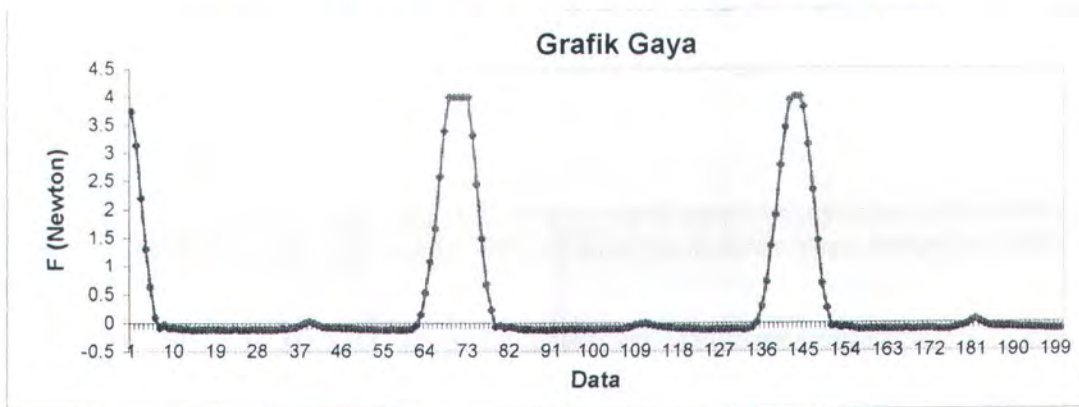



**Grafik Gaya, Simpangan, dan Tinggi Gelombang**  
 Kondisi Sarat 22.4 cm, Tinggi Gel. 4 cm, Periode 1.9 dt

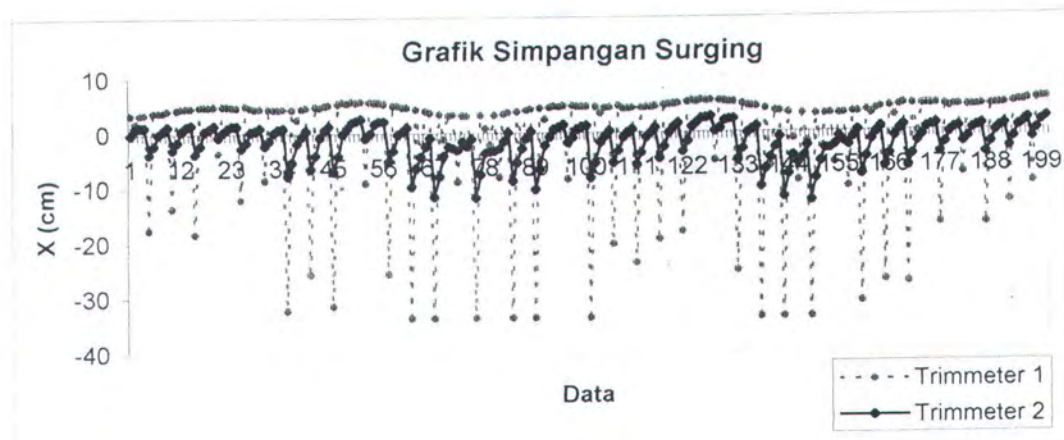
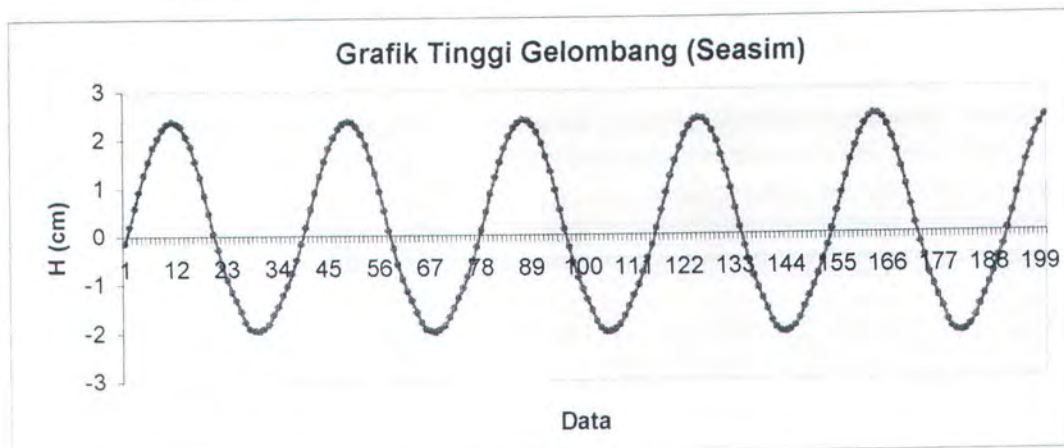
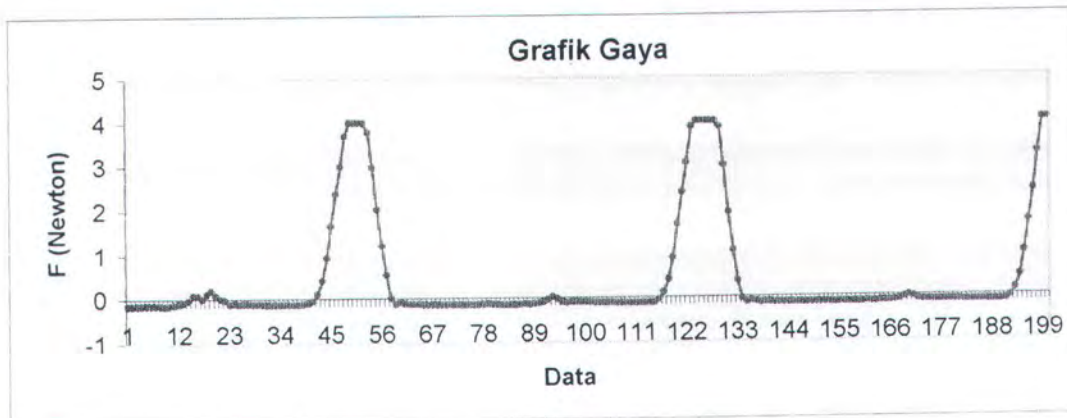



Grafik Gaya, Simpangan, dan Tinggi Gelombang  
Kondisi Sarat 22.4 cm, Tinggi Gel. 4 cm, Periode 2.0 dt

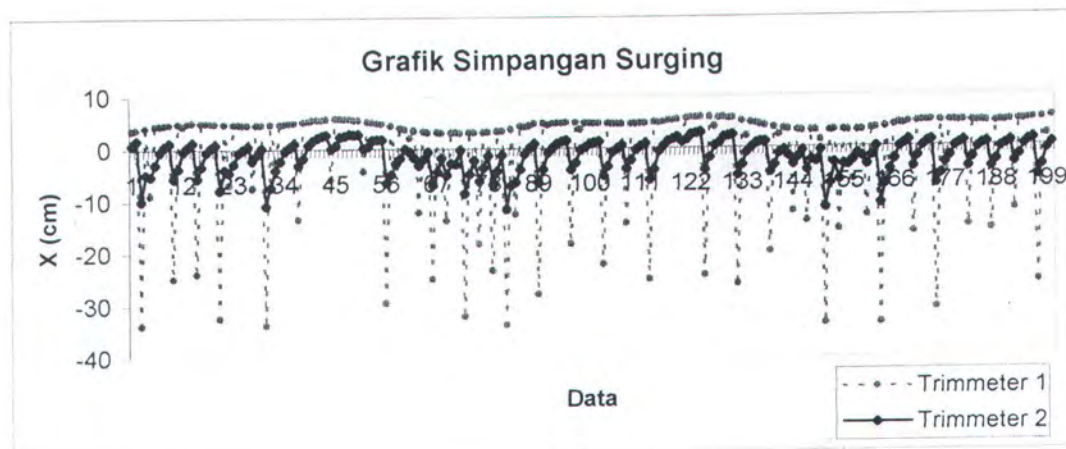
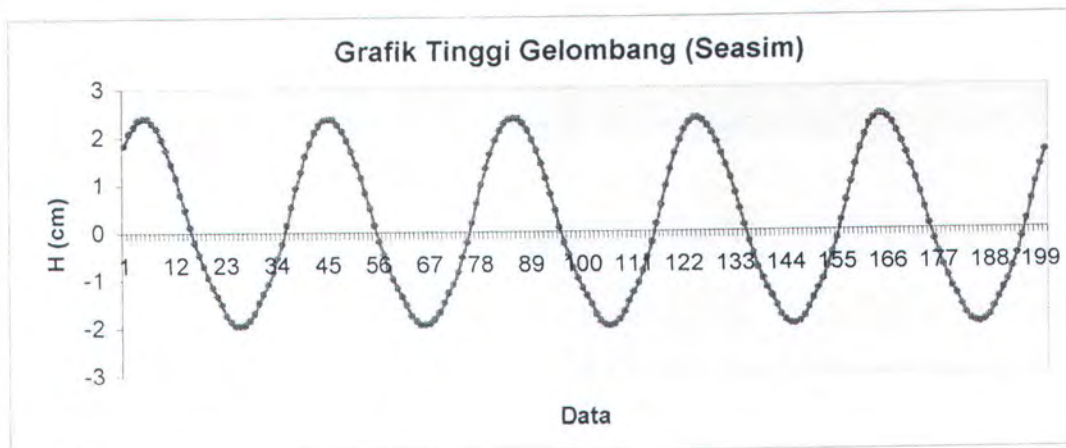
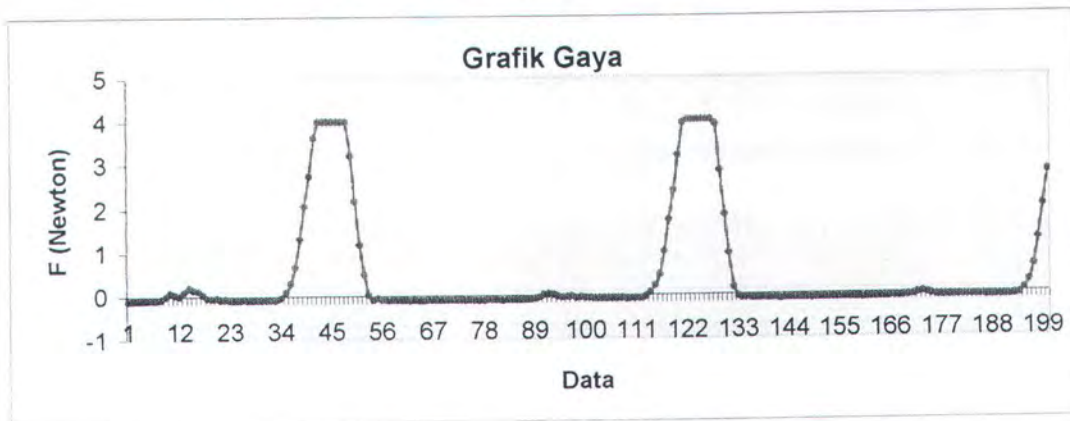



**Grafik Gaya, Simpangan, dan Tinggi Gelombang**  
 Kondisi Sarat 22.4 cm, Tinggi Gel. 2 cm, Periode 1.2 dt

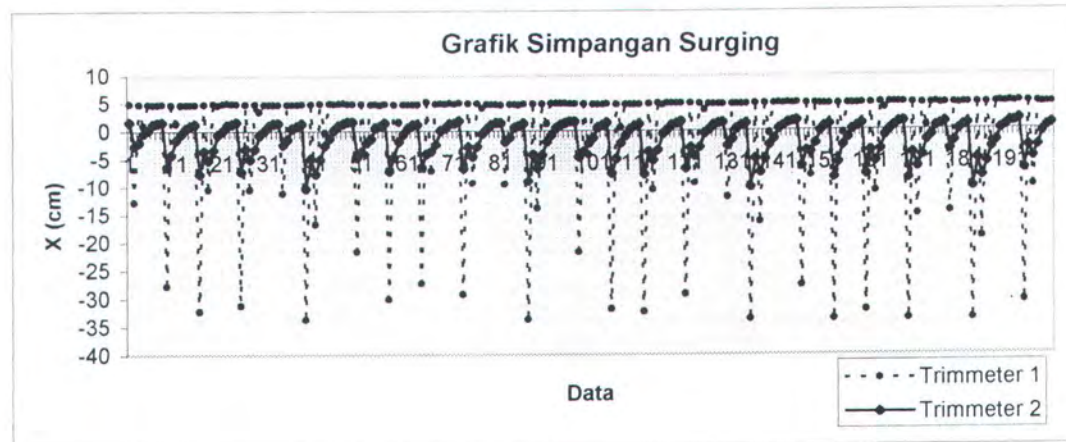
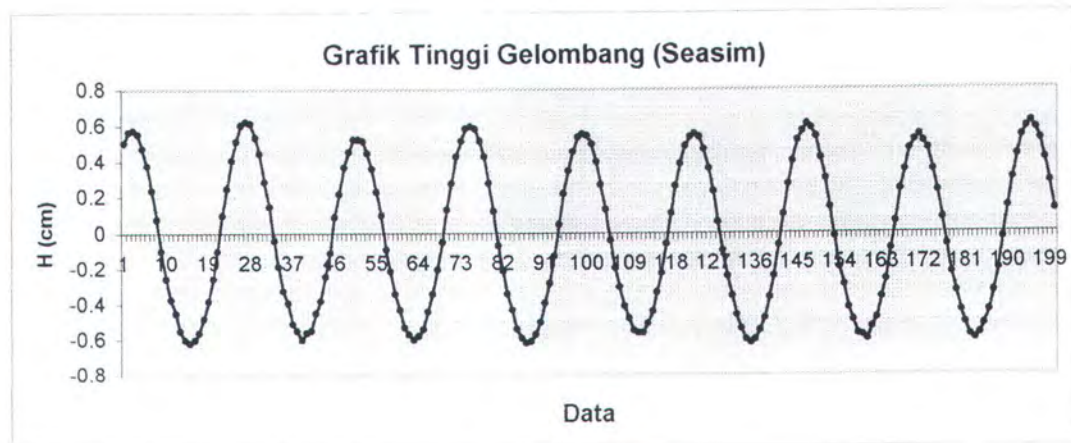
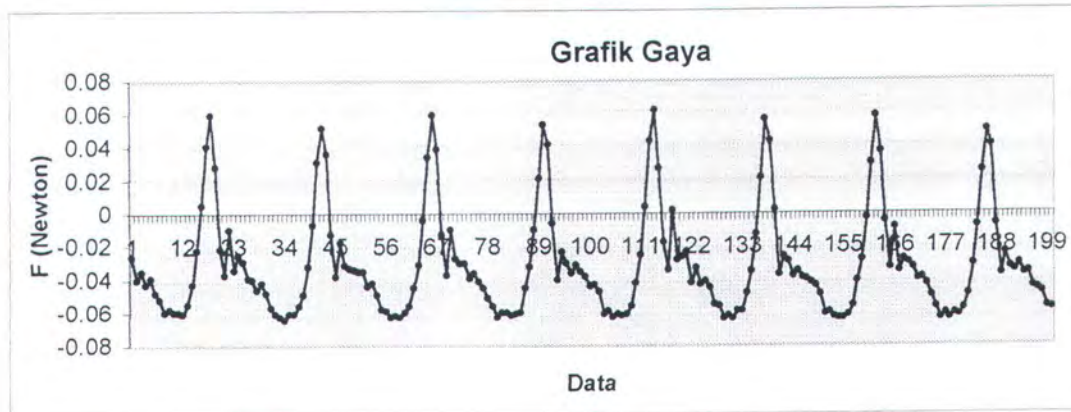



**Grafik Gaya, Simpangan, dan Tinggi Gelombang**  
**Kondisi Sarat 22.4 cm, Tinggi Gel. 2 cm, Periode 1.3 dt**

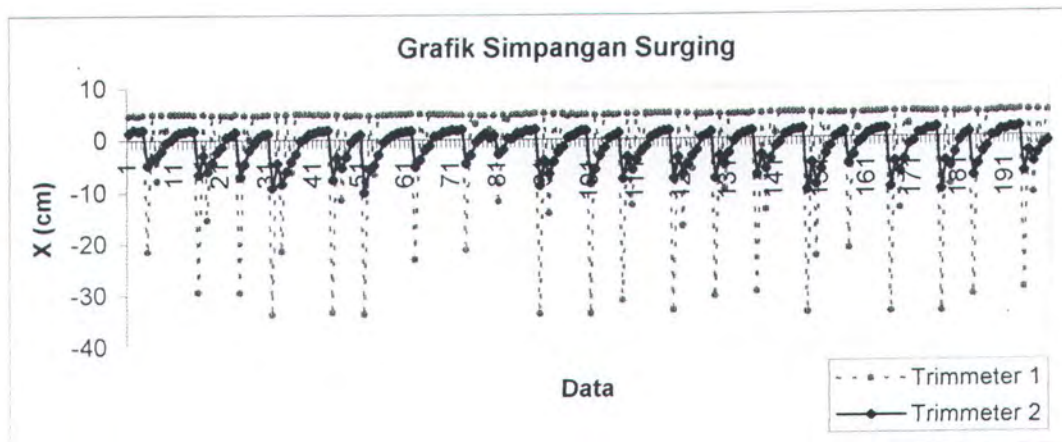
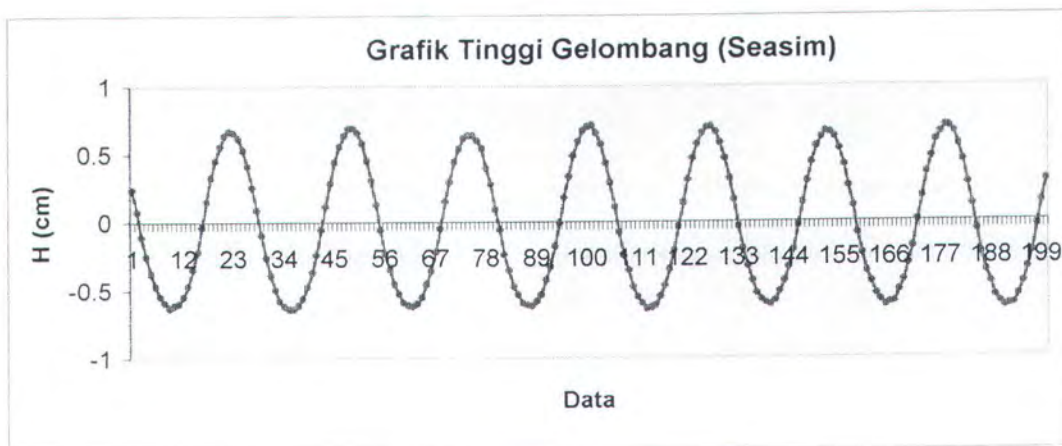
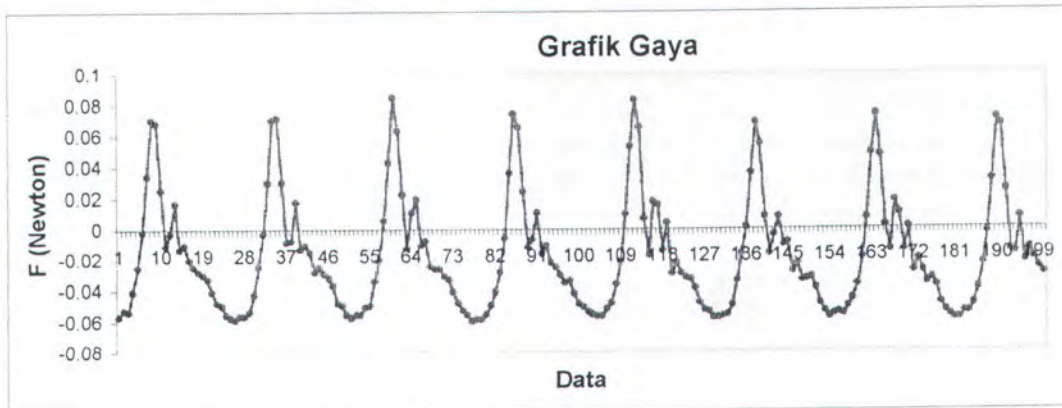



**Grafik Gaya, Simpangan, dan Tinggi Gelombang**  
 Kondisi Sarat 22.4 cm, Tinggi Gel. 2 cm, Periode 1.4 dt

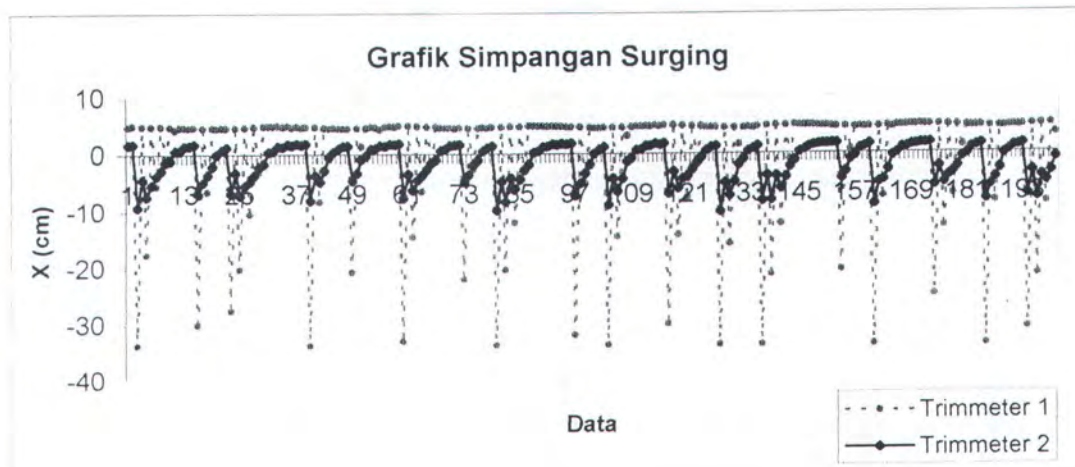
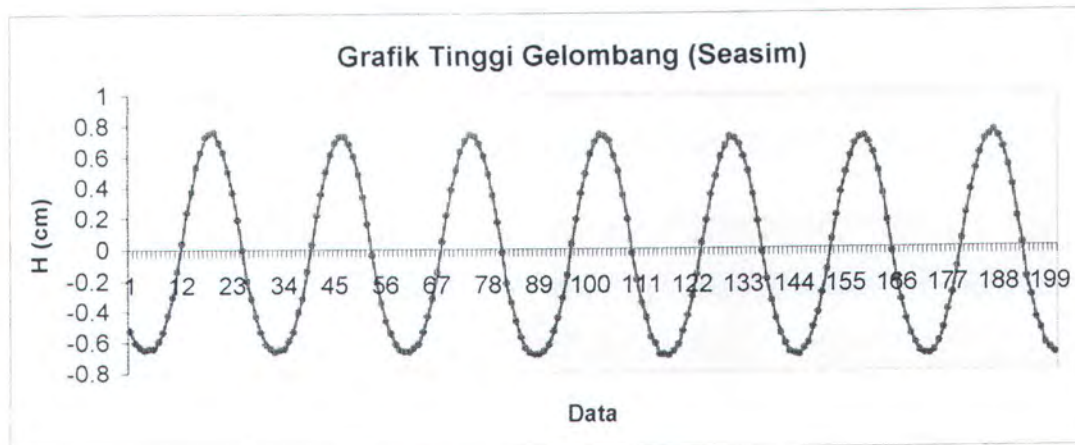
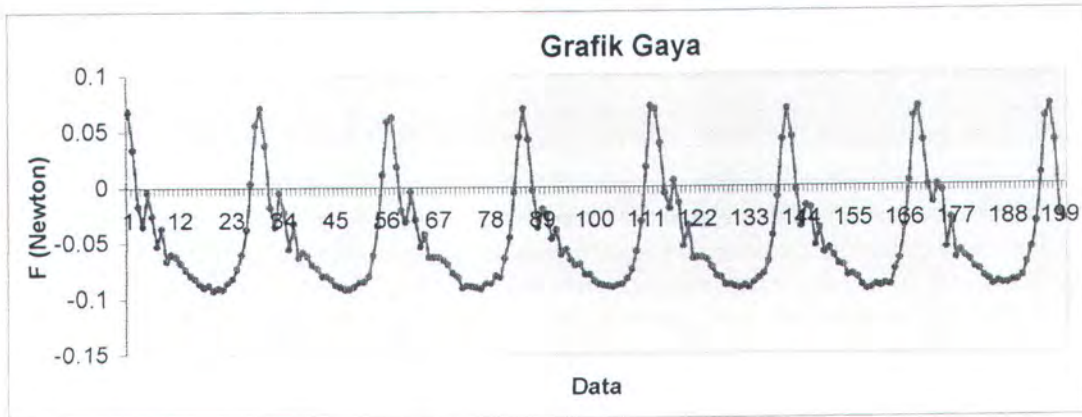



**Grafik Gaya, Simpangan, dan Tinggi Gelombang**  
 Kondisi Sarat 22.4 cm, Tinggi Gel. 2 cm, Periode 1.5 dt

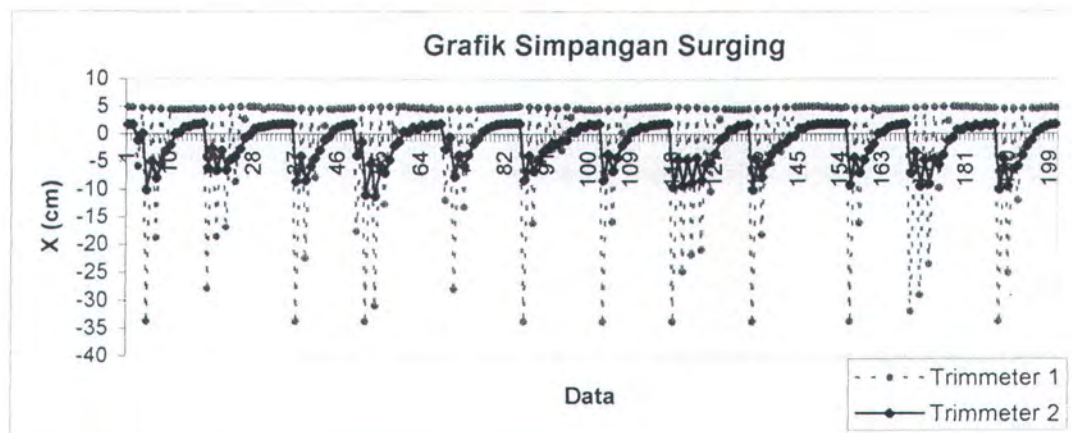
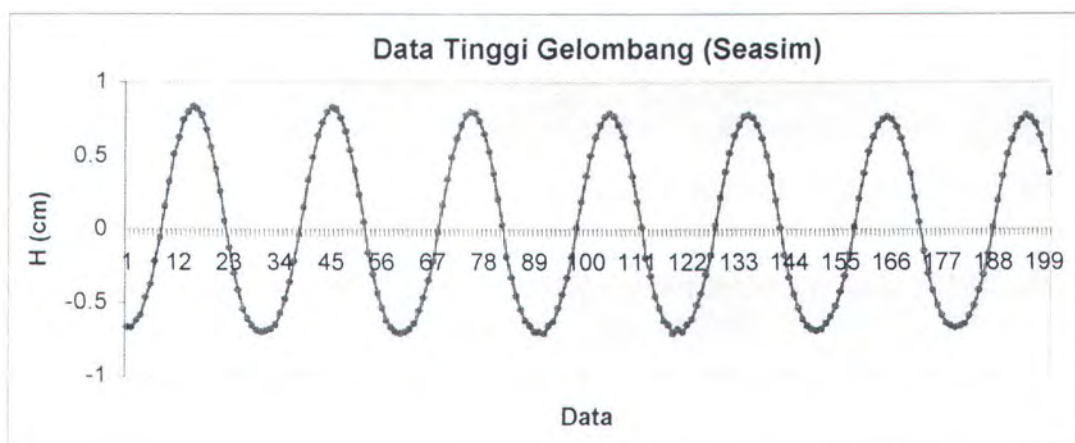
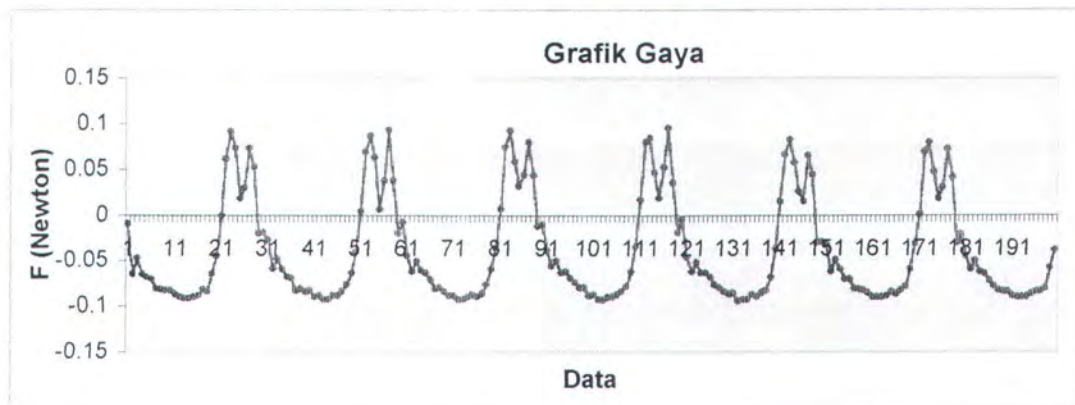



**Grafik Gaya, Simpangan, dan Tinggi Gelombang**  
Kondisi Sarat 22.4 cm, Tinggi Gel. 2 cm, Periode 1.6 dt

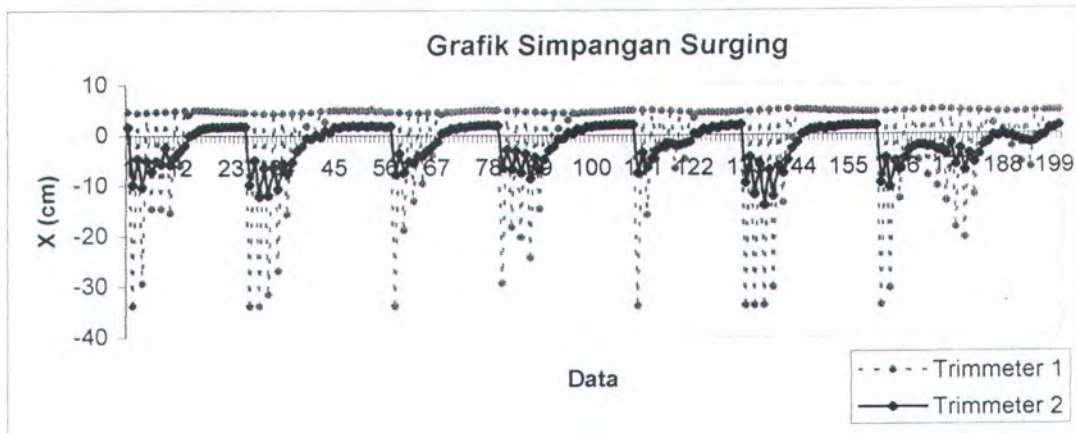
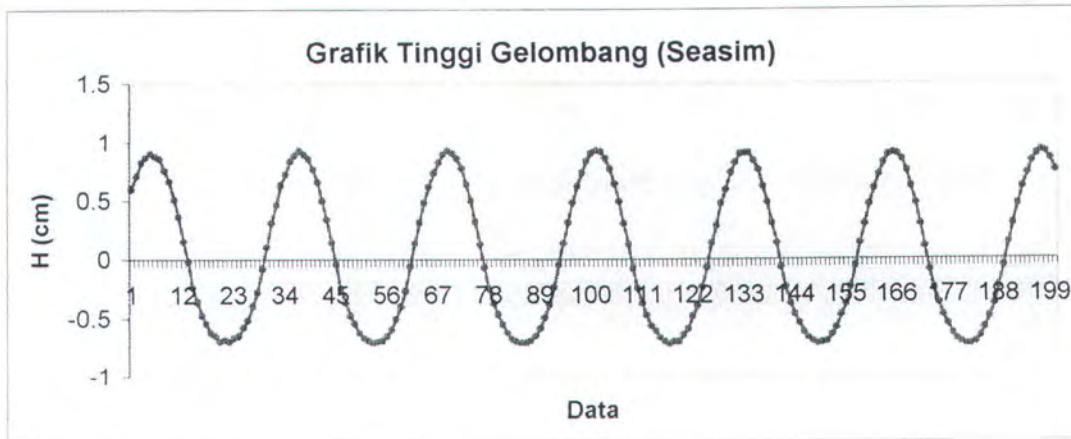
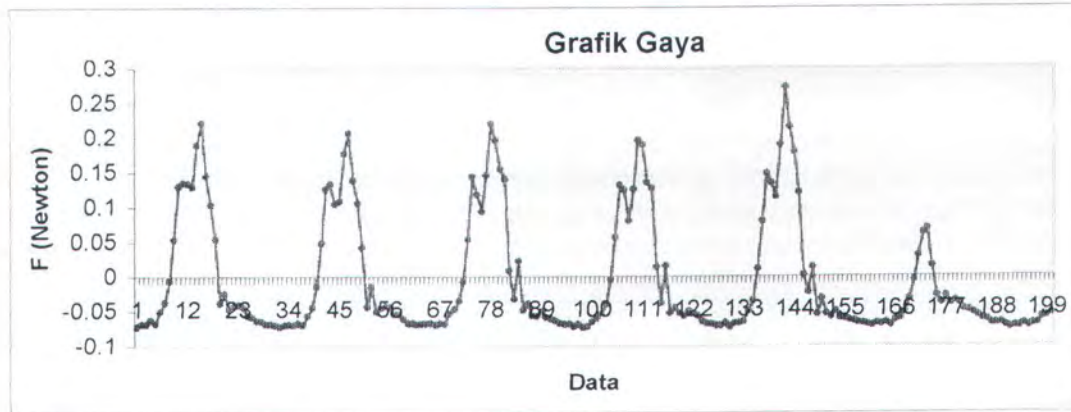



**Grafik Gaya, Simpangan, dan Tinggi Gelombang**  
 Kondisi Sarat 22.4 cm, Tinggi Gel. 2 cm, Periode 1.7 dt

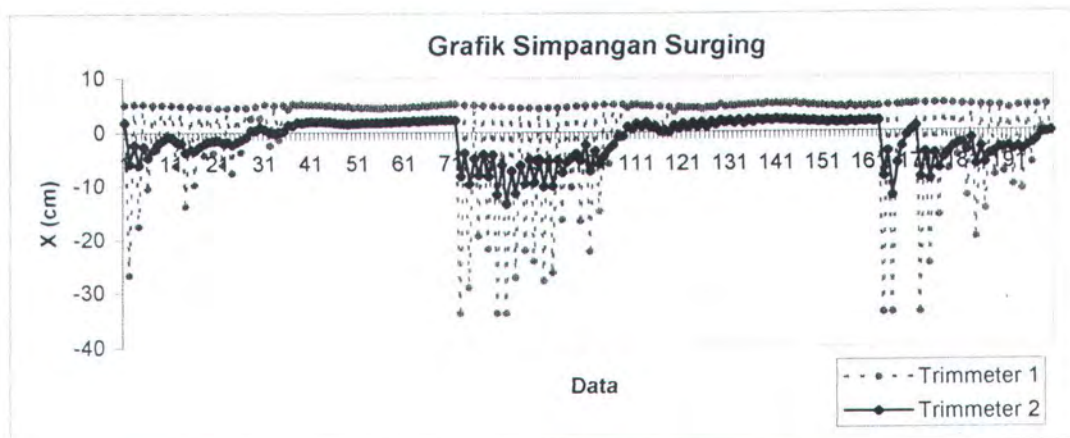
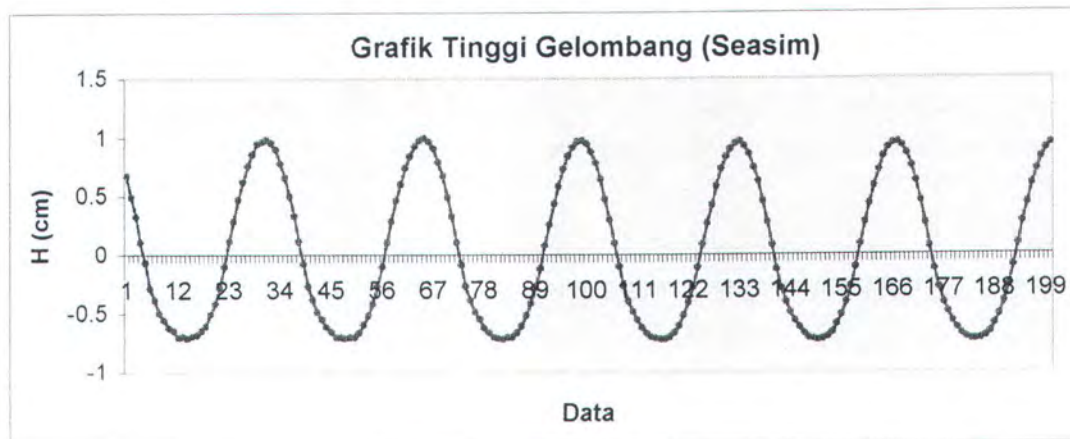
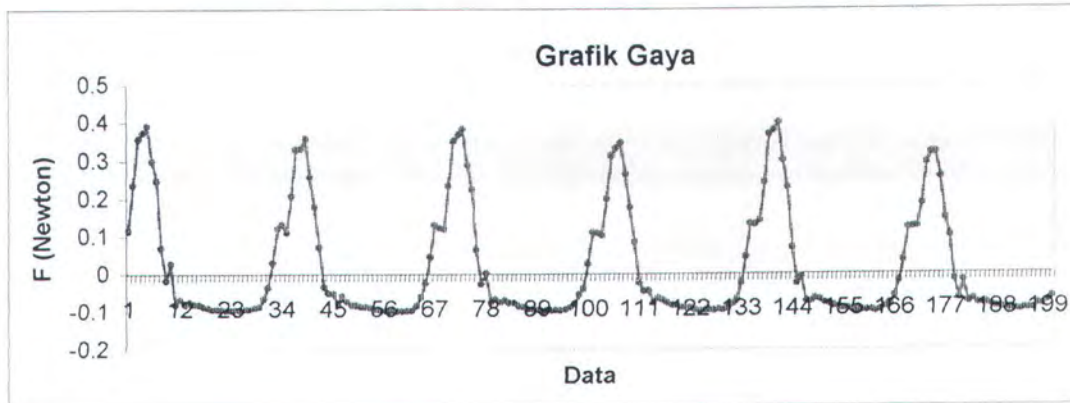



**Grafik Gaya, Simpangan, dan Tinggi Gelombang**  
 Kondisi Sarat 22.4 cm, Tinggi Gel. 2 cm, Periode 1.8 dt

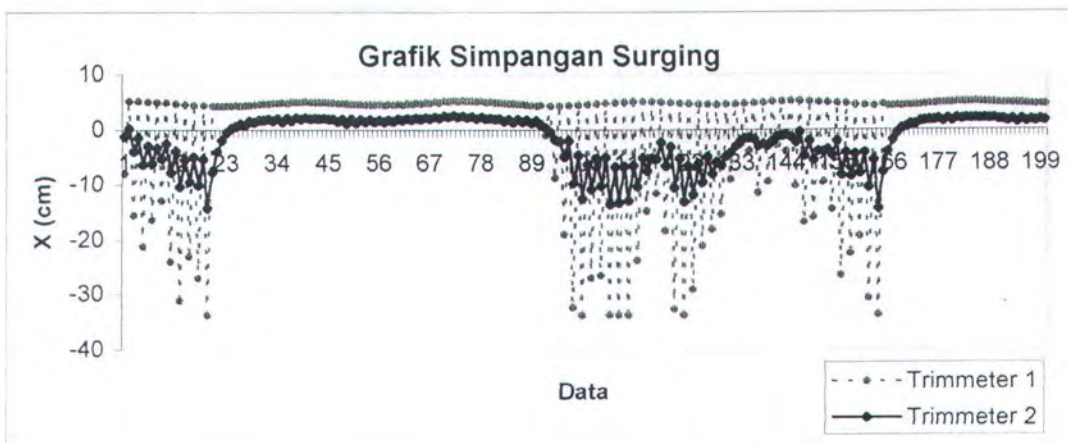
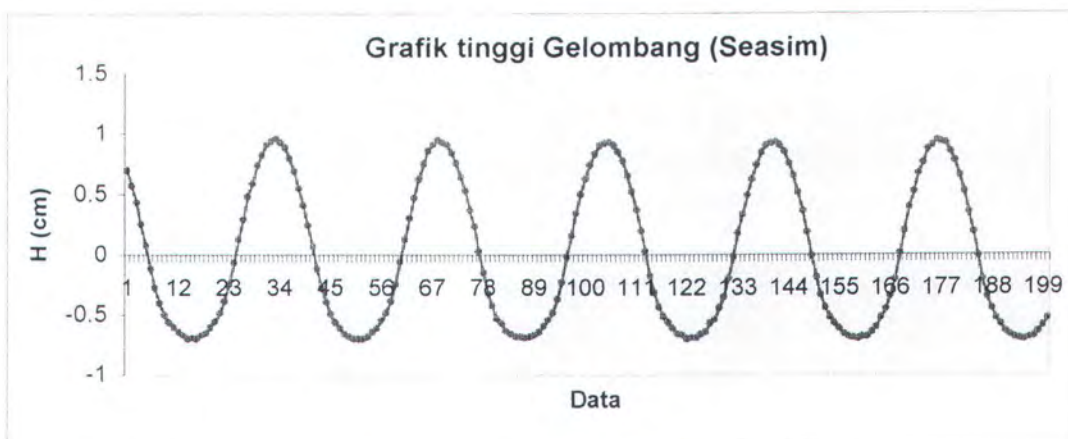
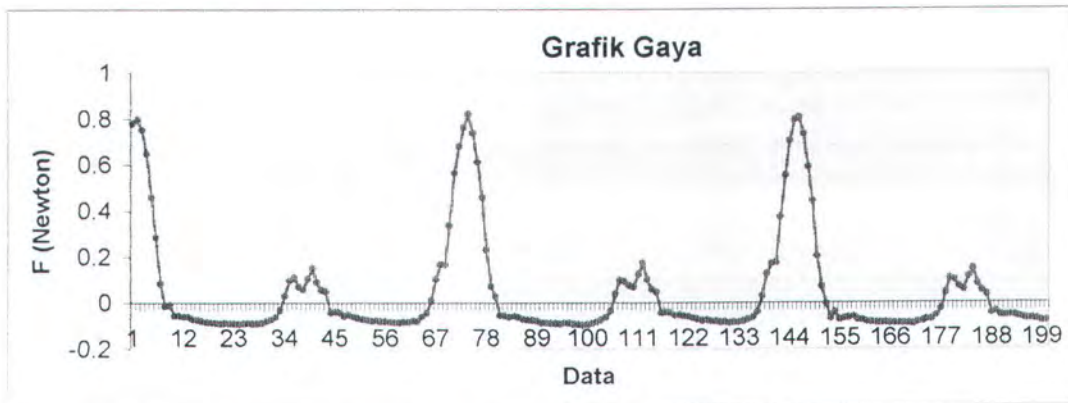



Grafik Gaya, Simpangan, dan Tinggi Gelombang  
Kondisi Sarat 22.4 cm, Tinggi Gel. 2 cm, Periode 1.9 dt

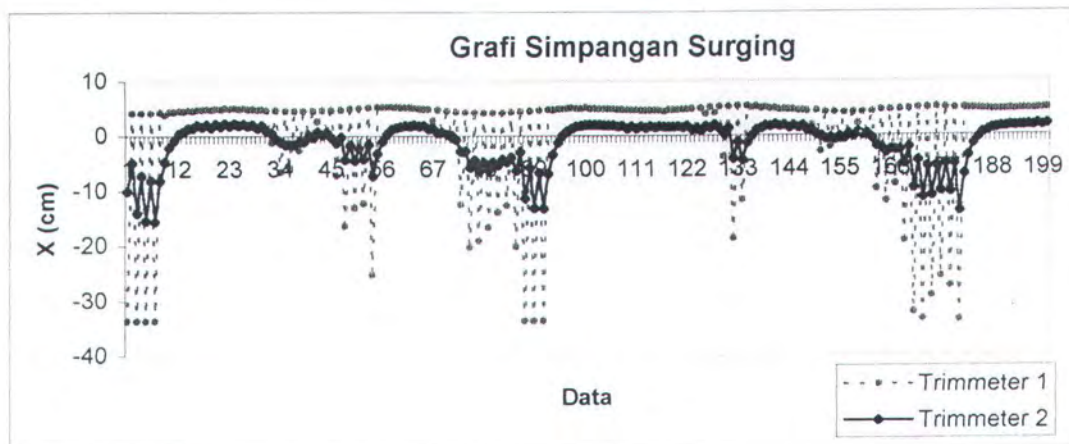
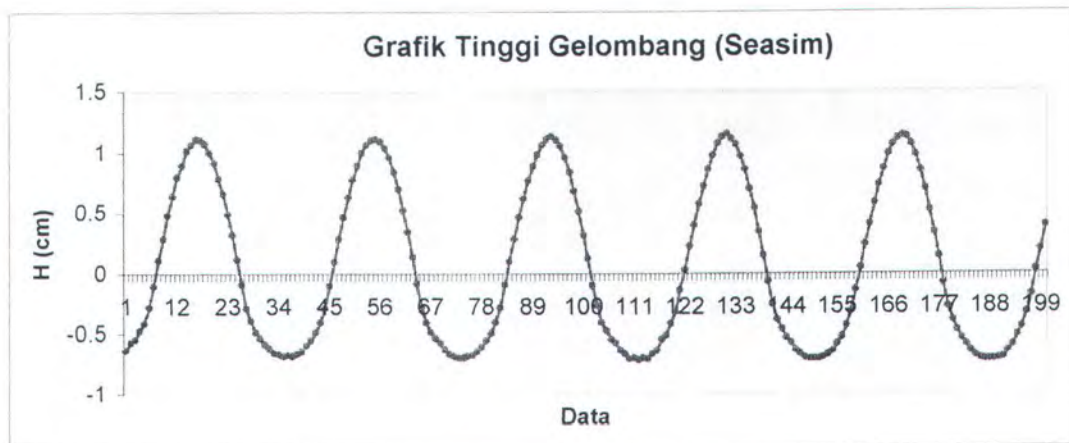
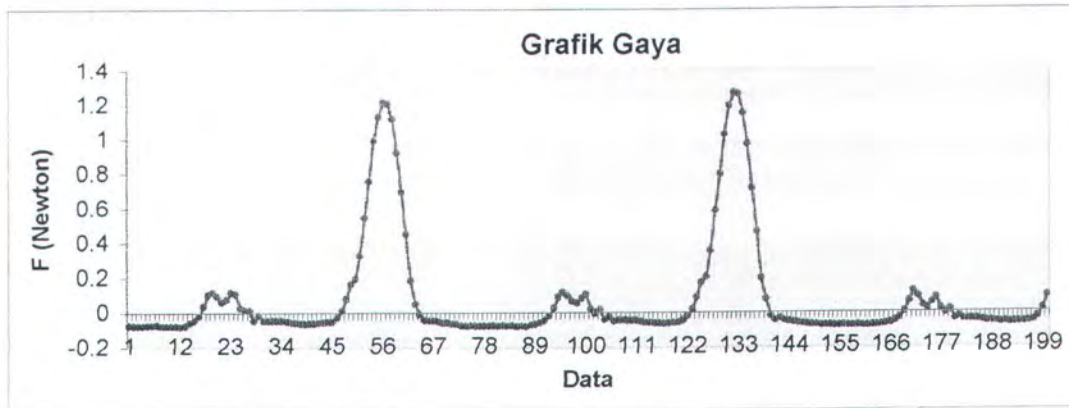



**Grafik Gaya, Simpangan, dan Tinggi Gelombang**  
 Kondisi Sarat 22.4 cm, Tinggi Gel. 2 cm, Periode 2.0 dt

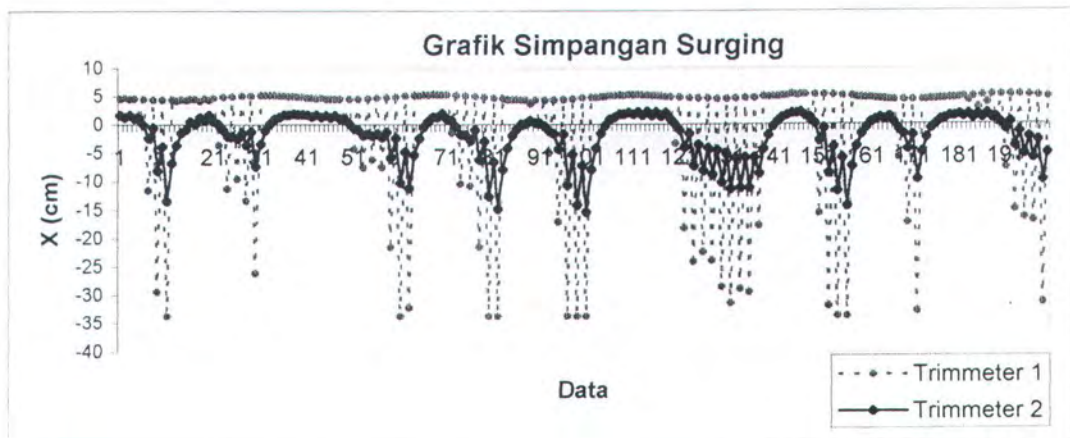
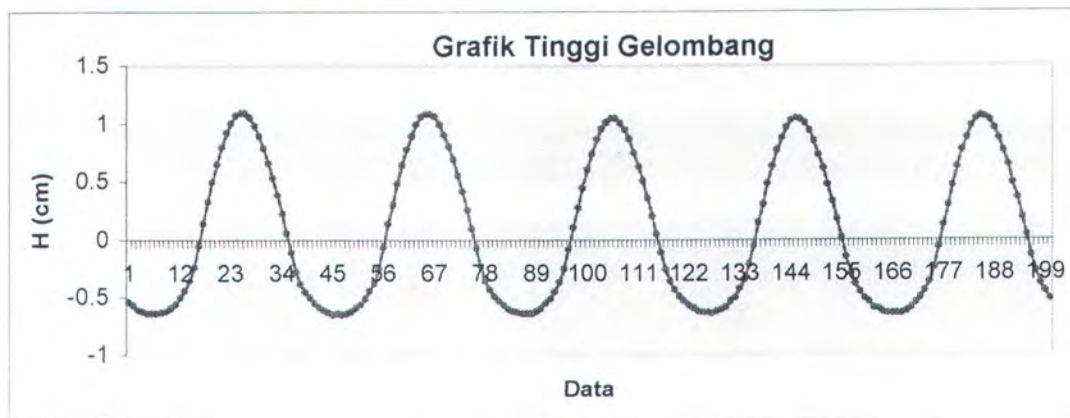
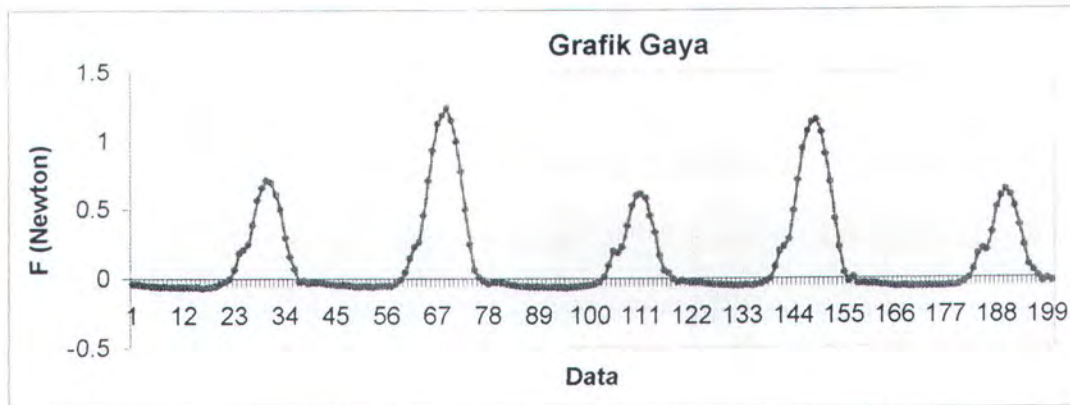



Grafik Gaya, Simpangan, dan Tinggi Gelombang  
Kondisi Sarat 11 cm, Tinggi Gel. 4 cm, Periode 1.2 dt

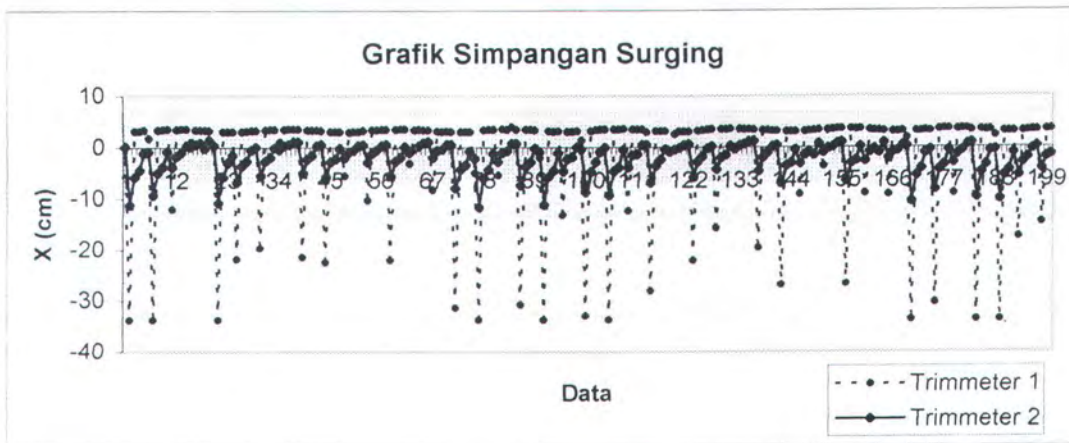
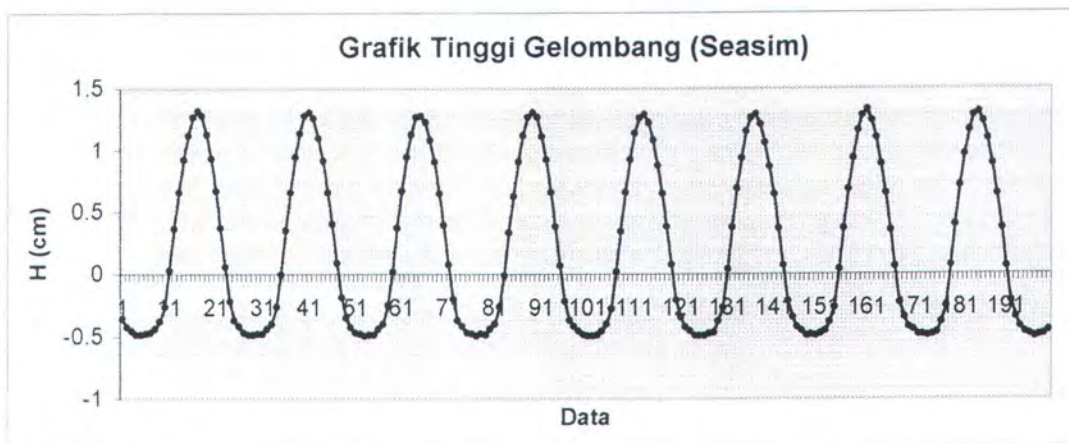
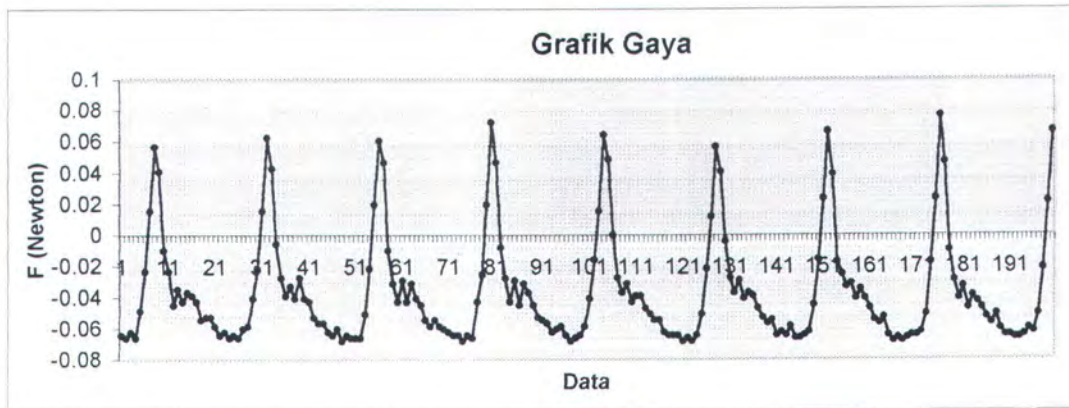



**Grafik Gaya, Simpangan, dan Tinggi Gelombang**  
 Kondisi Sarat 11 cm, Tinggi Gel. 4 cm, Periode 1.3 dt

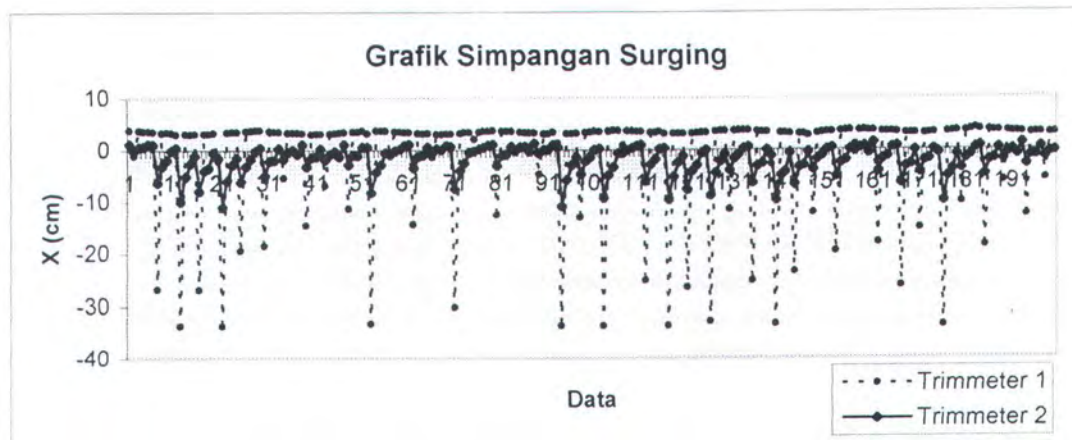
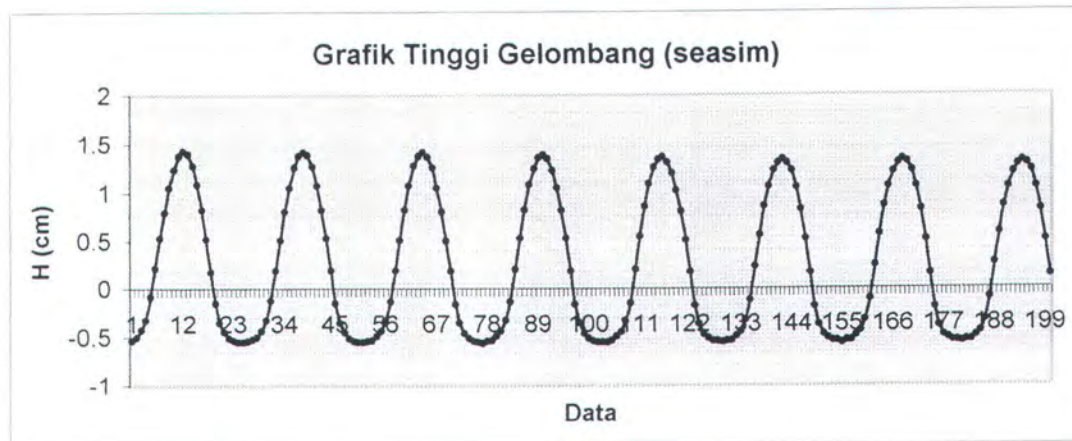
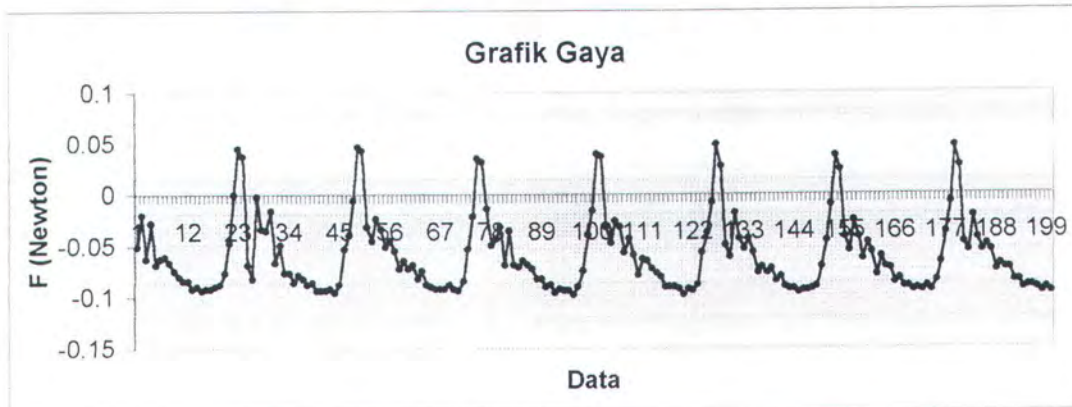



**Grafik Gaya, Simpangan, dan Tinggi Gelombang**  
 Kondisi Sarat 11 cm, Tinggi Gel. 4 cm, Periode 1.4 dt

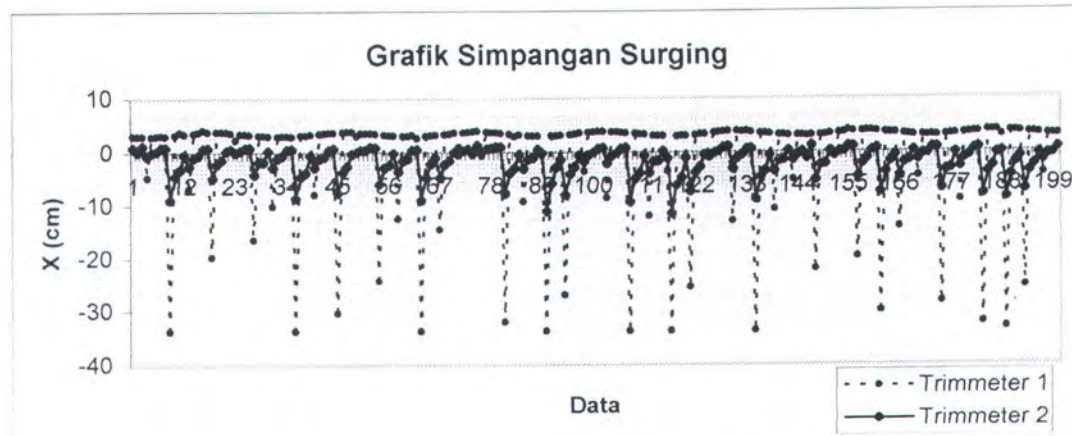
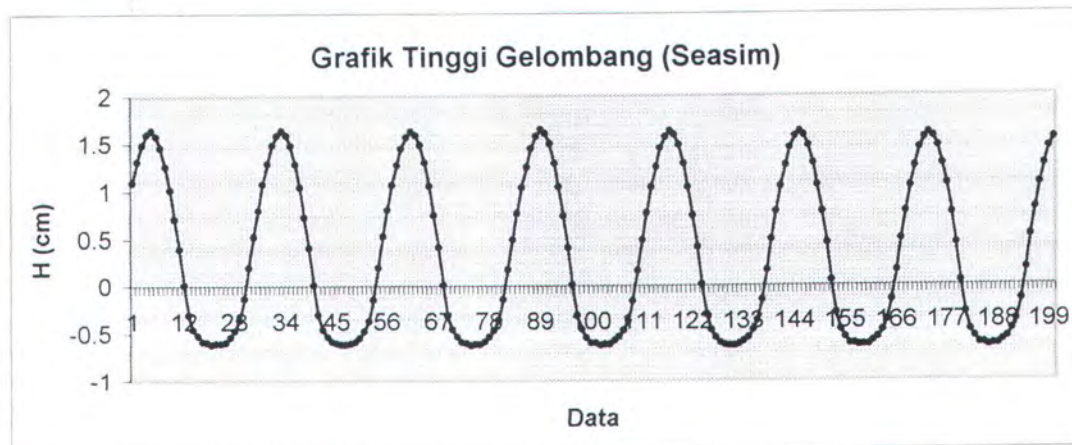
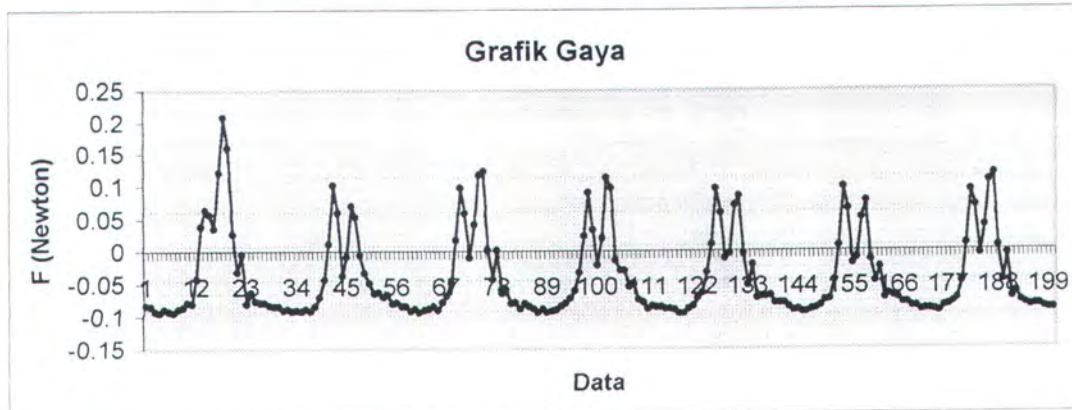



**Grafik Gaya, Simpangan, dan Tinggi Gelombang**  
 Kondisi Sarat 11 cm, Tinggi Gel. 4 cm, Periode 1.5 dt

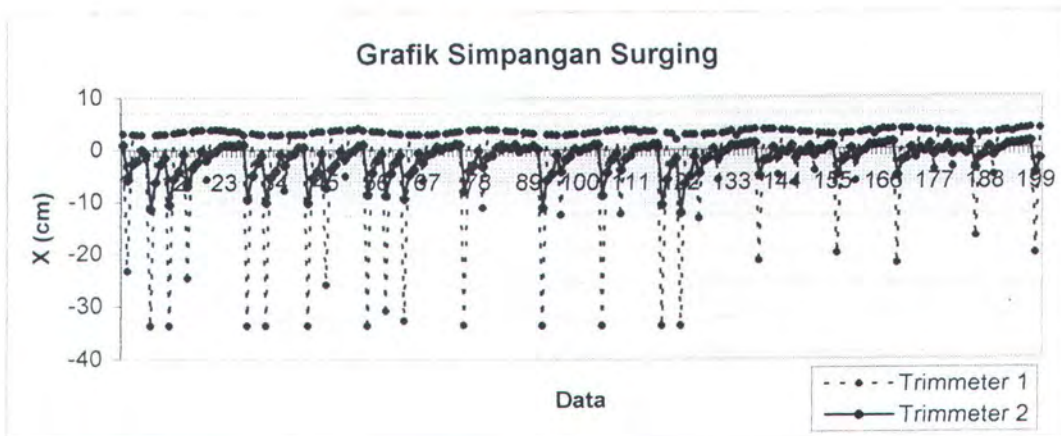
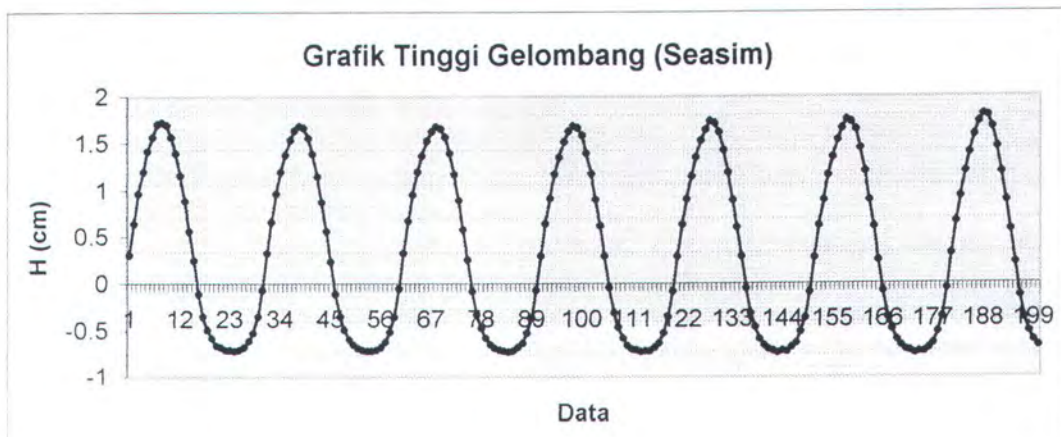
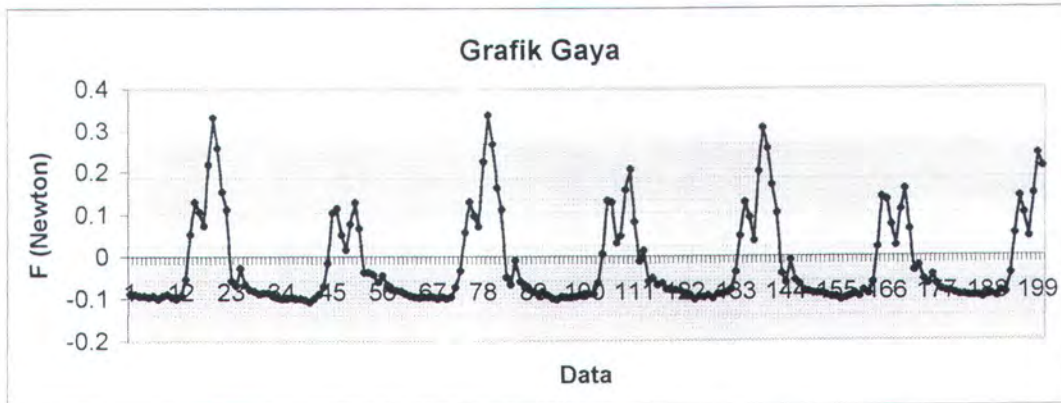



**Grafik Gaya, Simpangan, dan Tinggi Gelombang**  
 Kondisi Sarat 11 cm, Tinggi Gel. 4 cm, Periode 1.6 dt

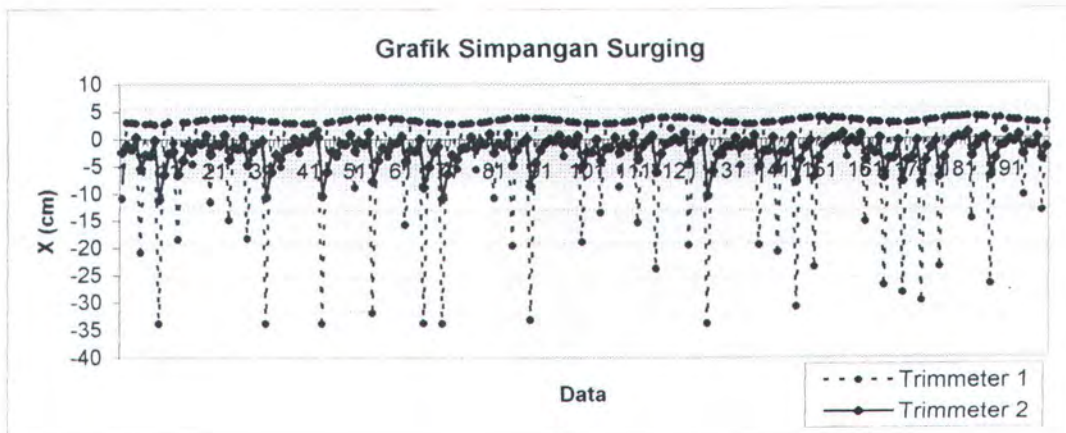
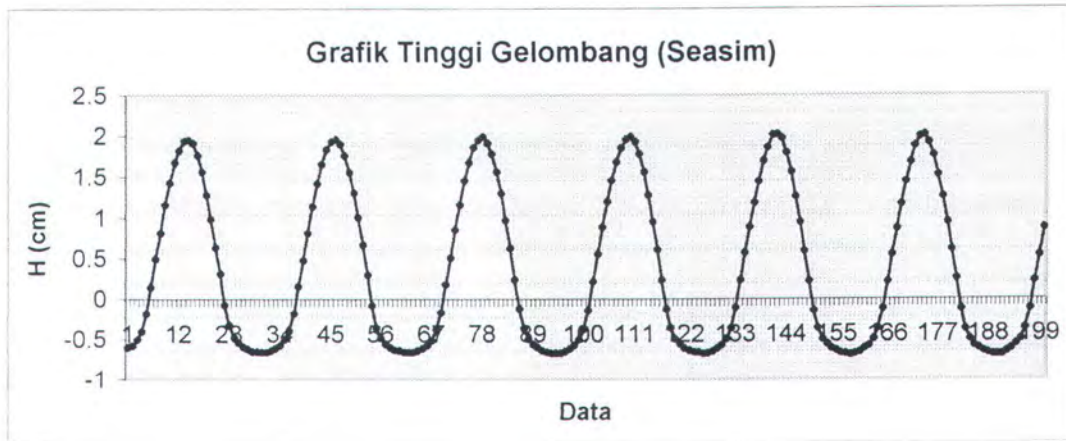
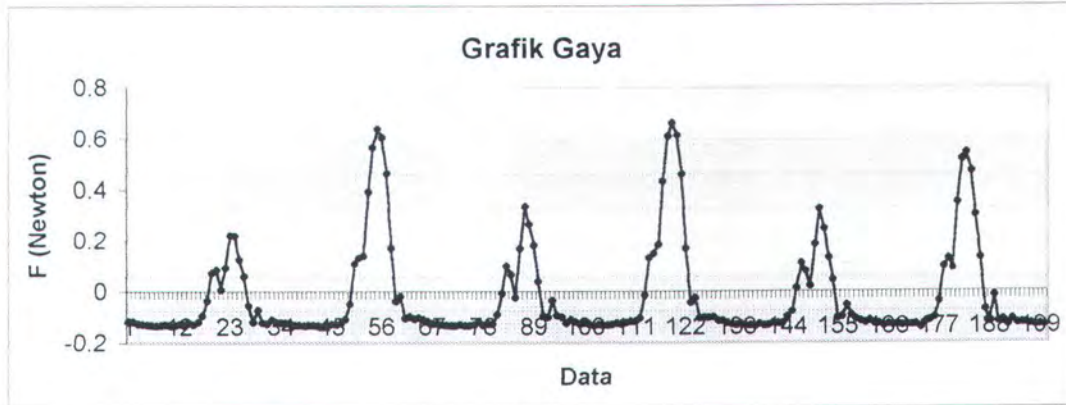



**Grafik Gaya, Simpangan, dan Tinggi Gelombang**  
 Kondisi Sarat 11 cm, Tinggi Gel. 4 cm, Periode 1.7 dt

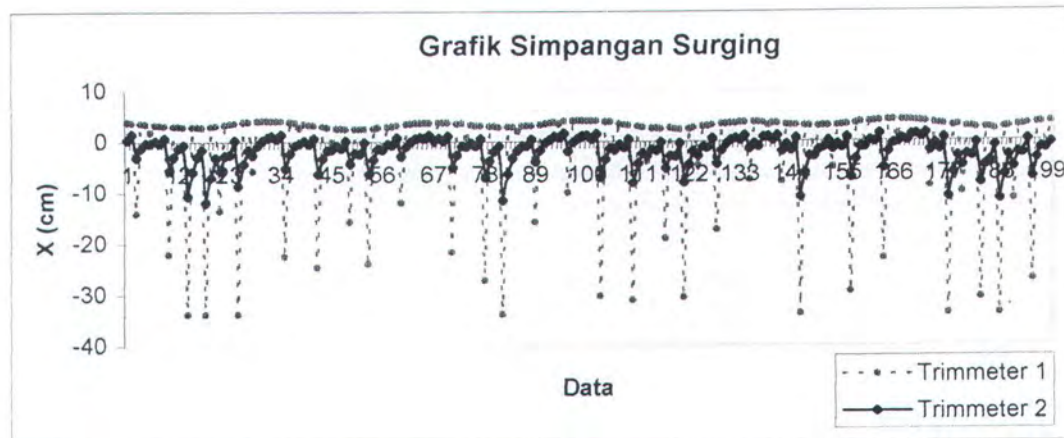
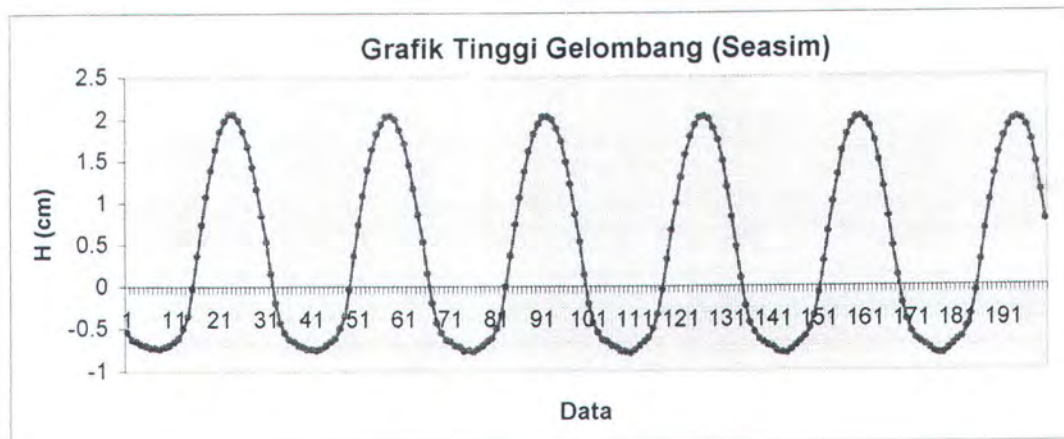
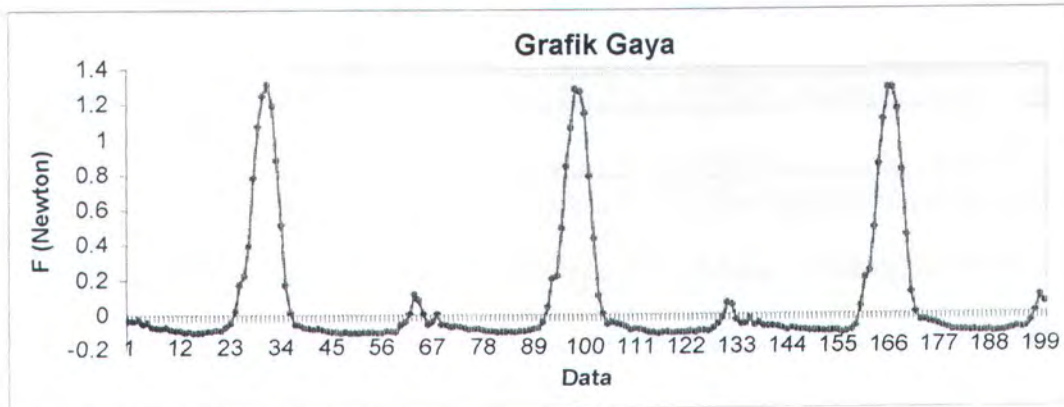



**Grafik Gaya, Simpangan, dan Tinggi Gelombang**  
 Kondisi Sarat 11 cm, Tinggi Gel. 4 cm, Periode 1.8 dt

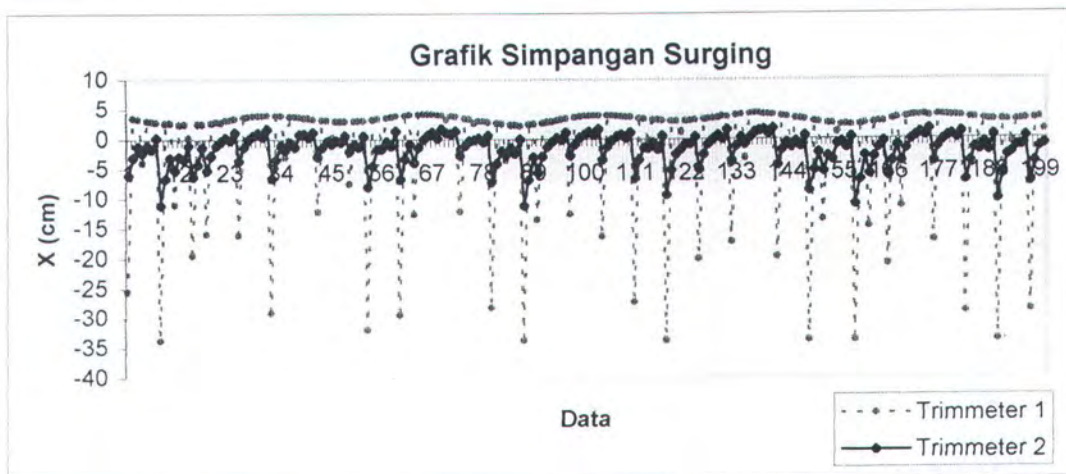
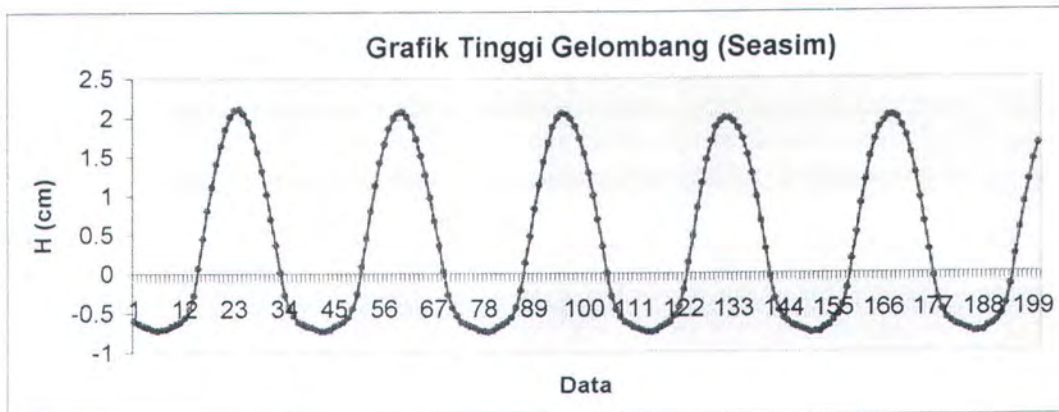
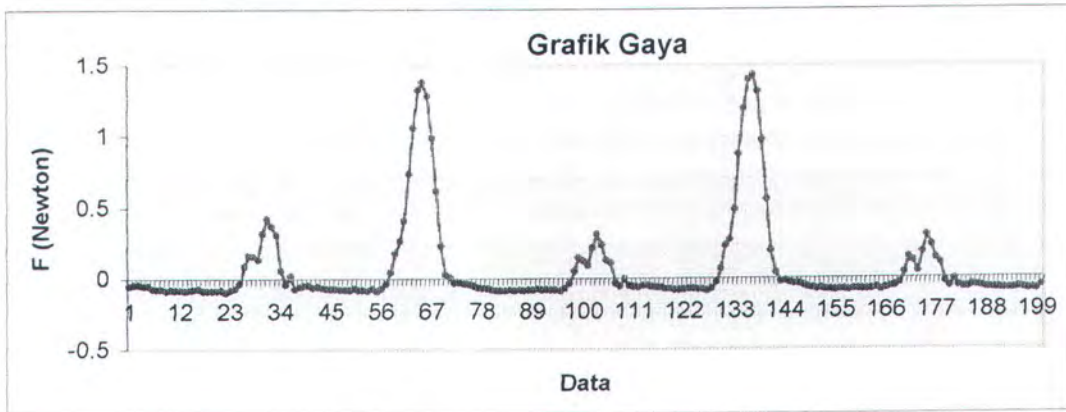



**Grafik Gaya, Simpangan, dan Tinggi Gelombang**  
 Kondisi Sarat 11 cm, Tinggi Gel. 4 cm, Periode 1.9 dt

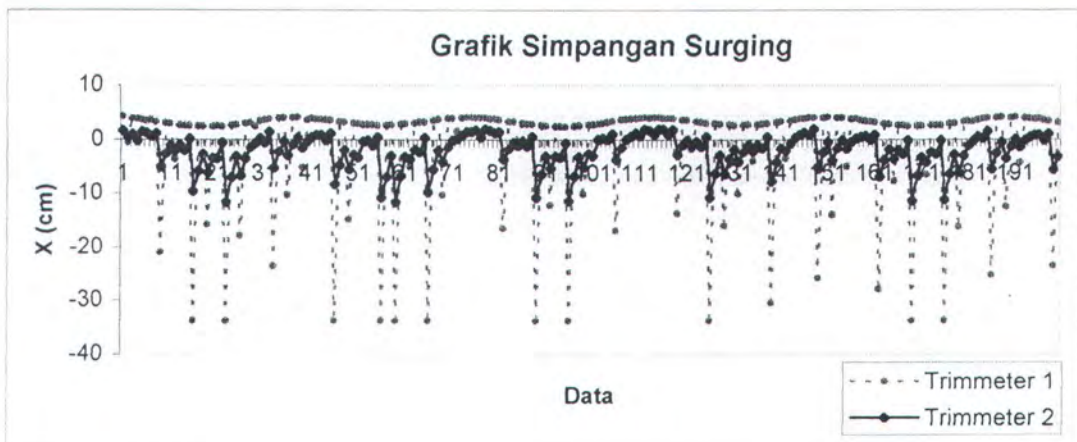
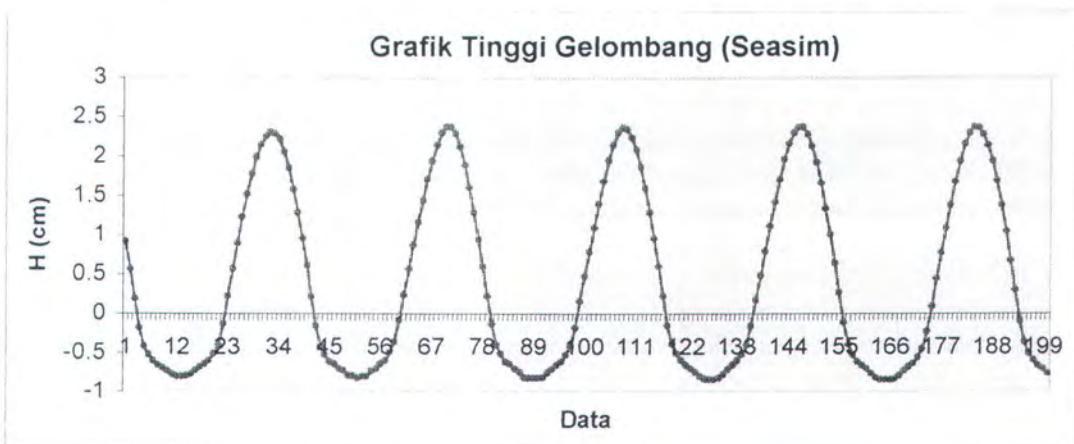
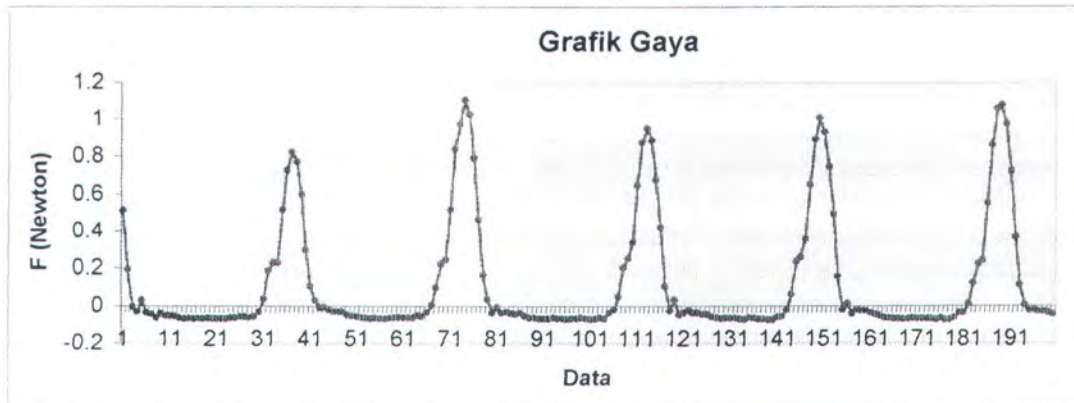



**Grafik Gaya, Simpangan, dan Tinggi Gelombang**  
 Kondisi Sarat 11 cm, Tinggi Gel. 4 cm, Periode 2.0 dt

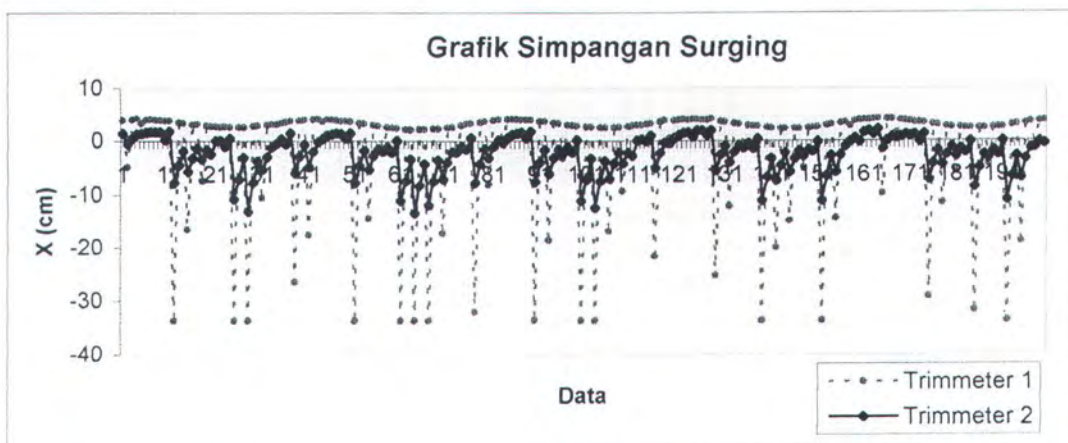
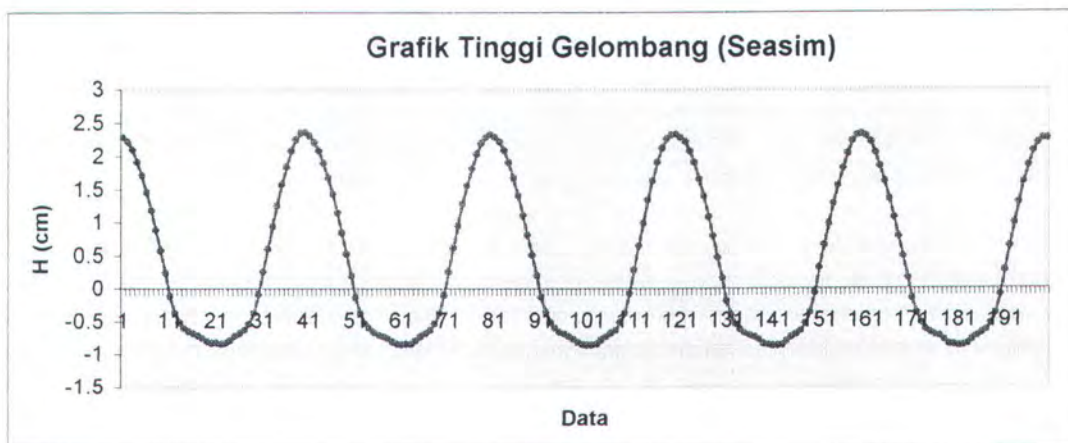
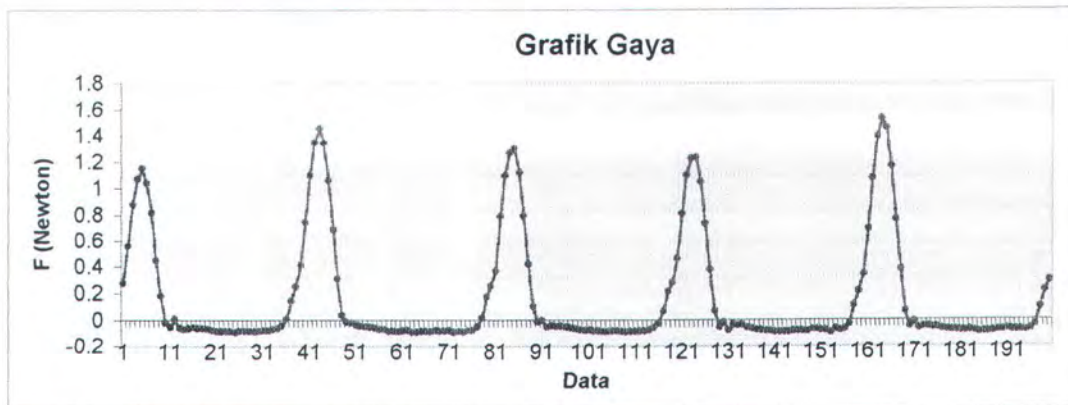



**Grafik Gaya, Simpangan, dan Tinggi Gelombang**  
**Kondisi Sarat 11 cm, Tinggi Gel. 2 cm, Periode 1.2 dt**

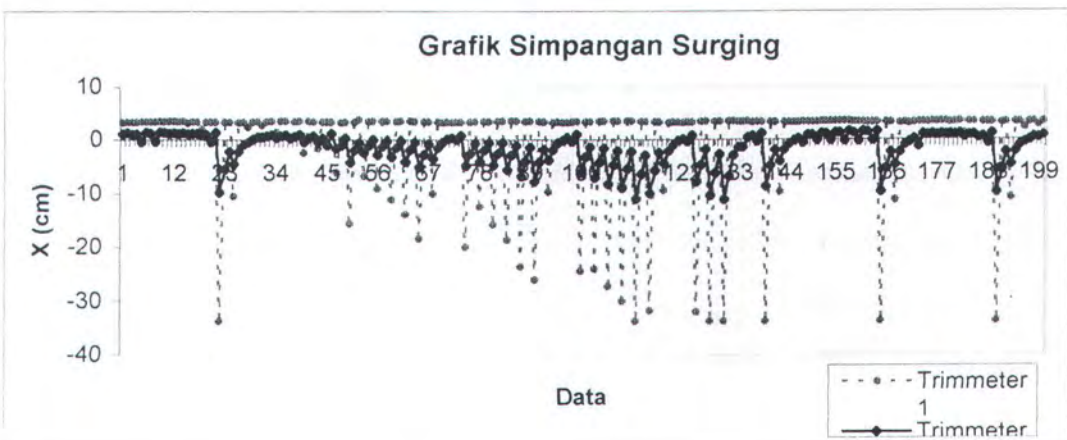
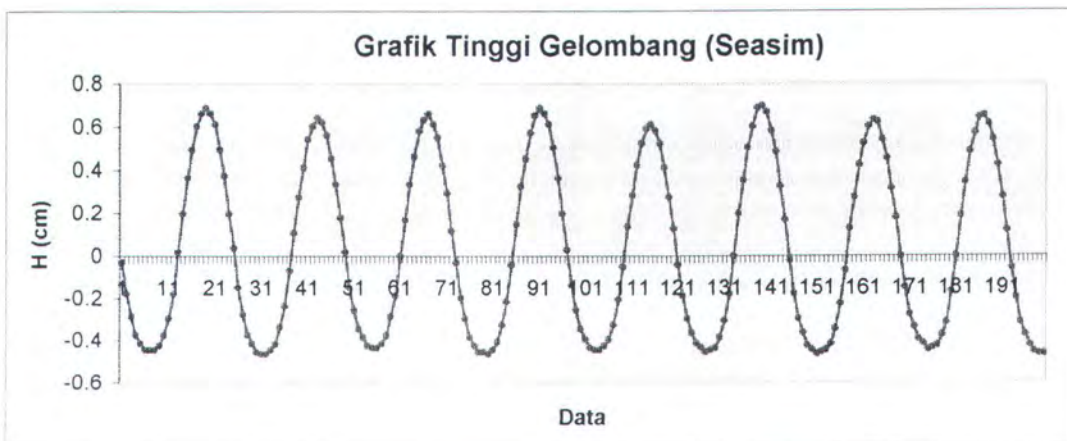
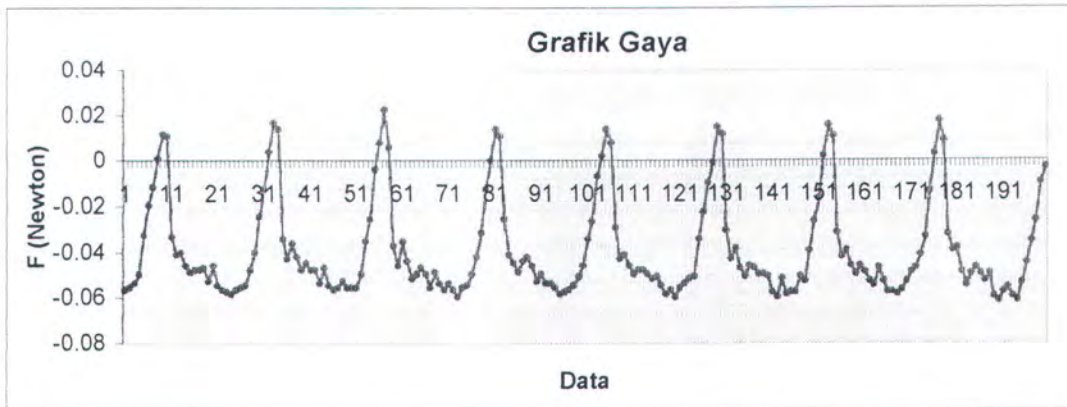



**Grafik Gaya, Simpangan, dan Tinggi Gelombang**  
 Kondisi Sarat 11 cm, Tinggi Gel. 2 cm, Periode 1.3 dt

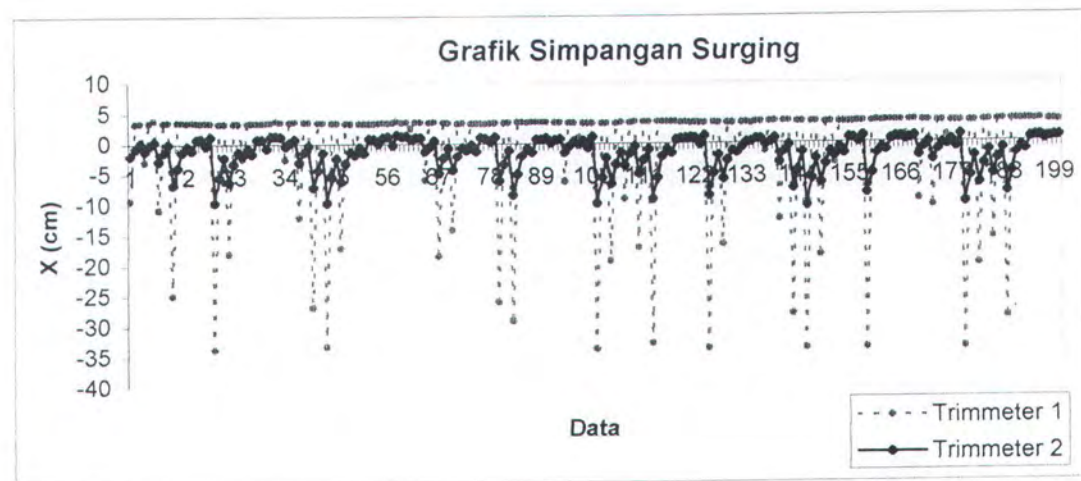
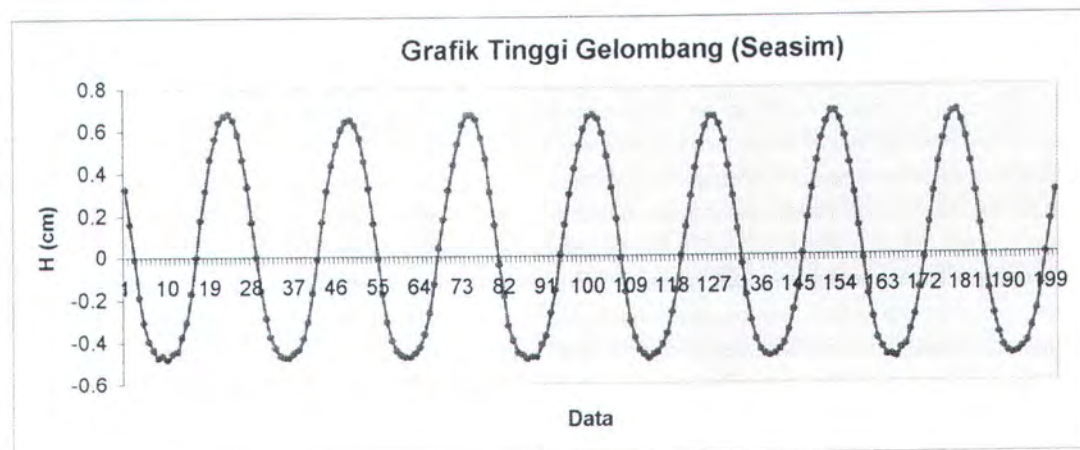
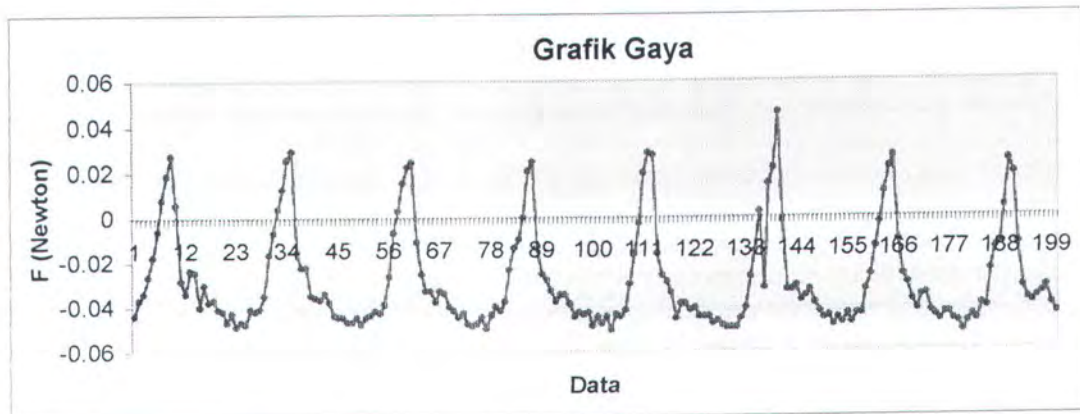



**Grafik Gaya, Simpangan, dan Tinggi Gelombang**  
 Kondisi Sarat 11 cm, Tinggi Gel. 2 cm, Periode 1.4 dt

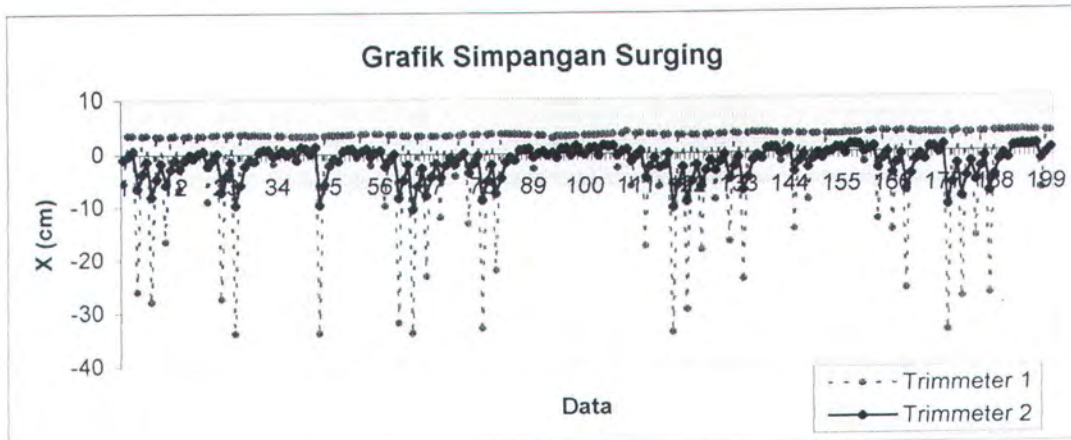
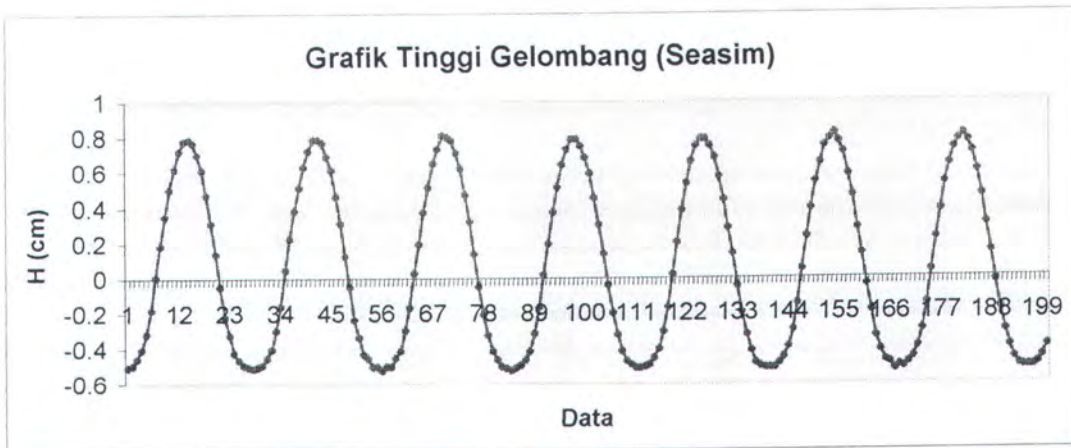
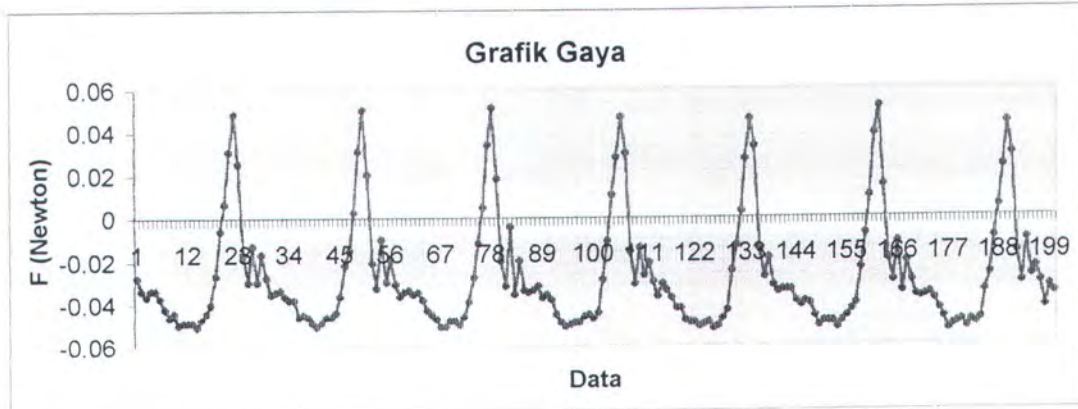



**Grafik Gaya, Simpangan, dan Tinggi Gelombang**  
 Kondisi Sarat 11 cm, Tinggi Gel. 2 cm, Periode 1.5 dt

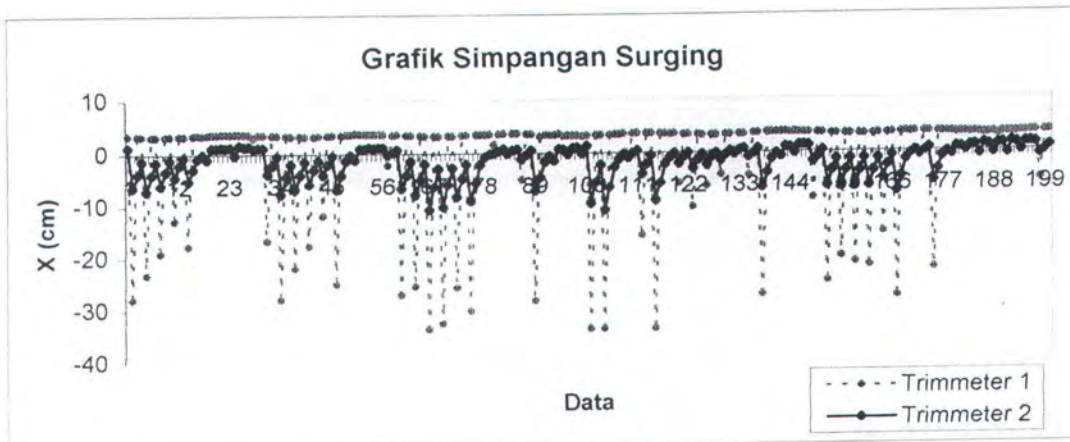
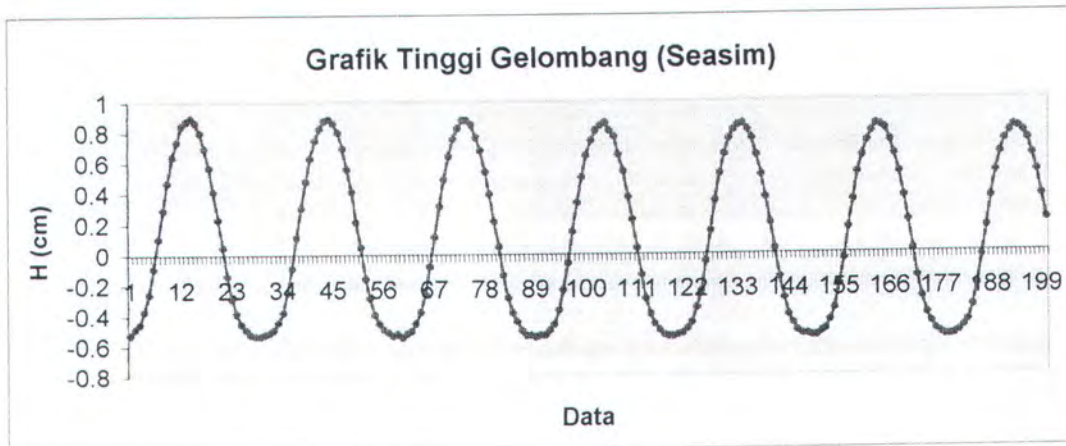
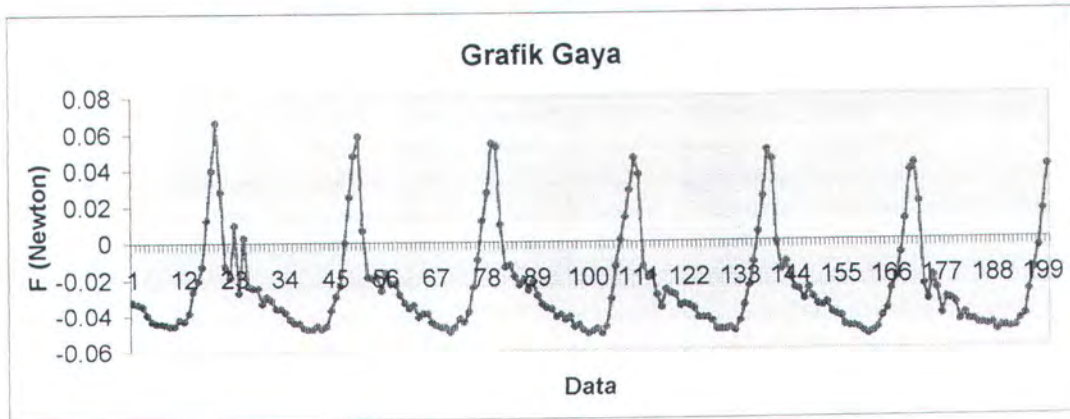



**Grafik Gaya, Simpangan, dan Tinggi Gelombang**  
 Kondisi Sarat 11 cm, Tinggi Gel. 2 cm, Periode 1.6 dt

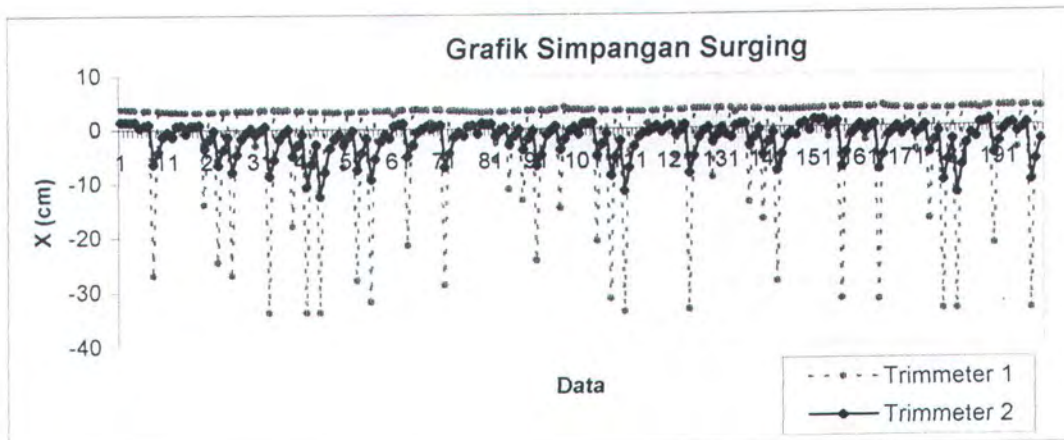
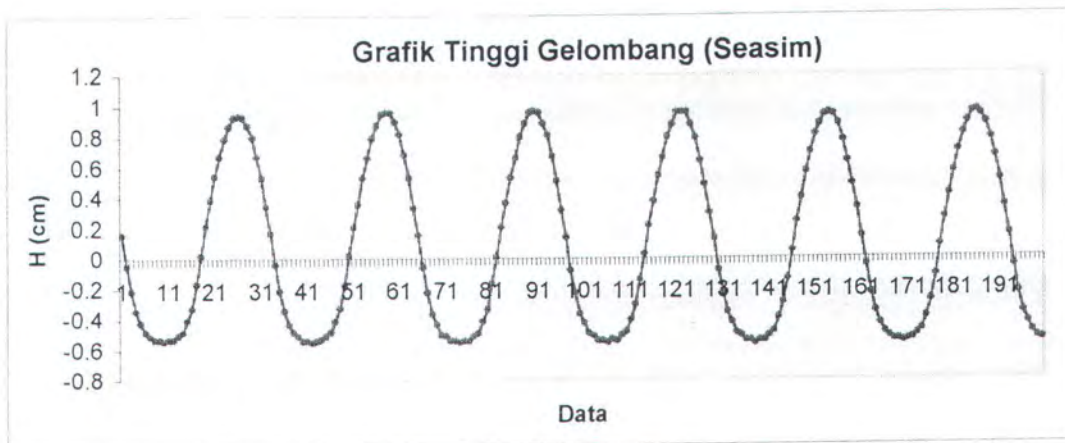
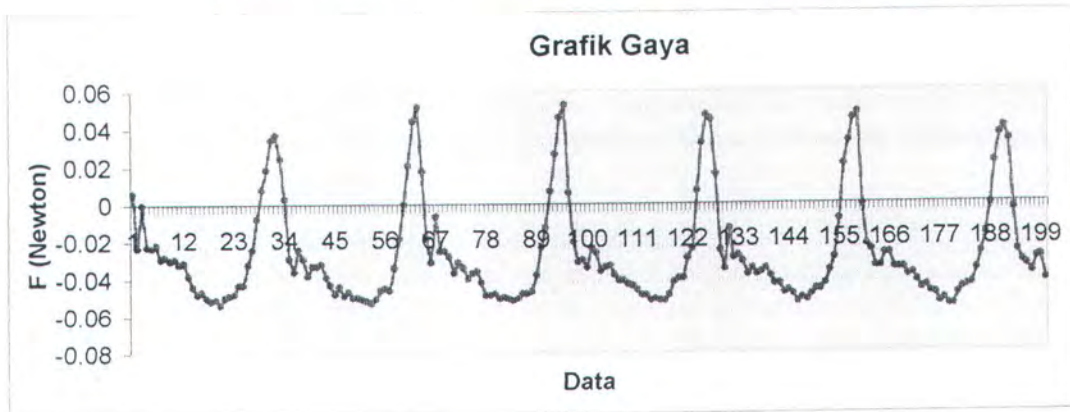



**Grafik Gaya, Simpangan, dan Tinggi Gelombang**  
 Kondisi Sarat 11 cm, Tinggi Gel. 2 cm, Periode 1.7 dt

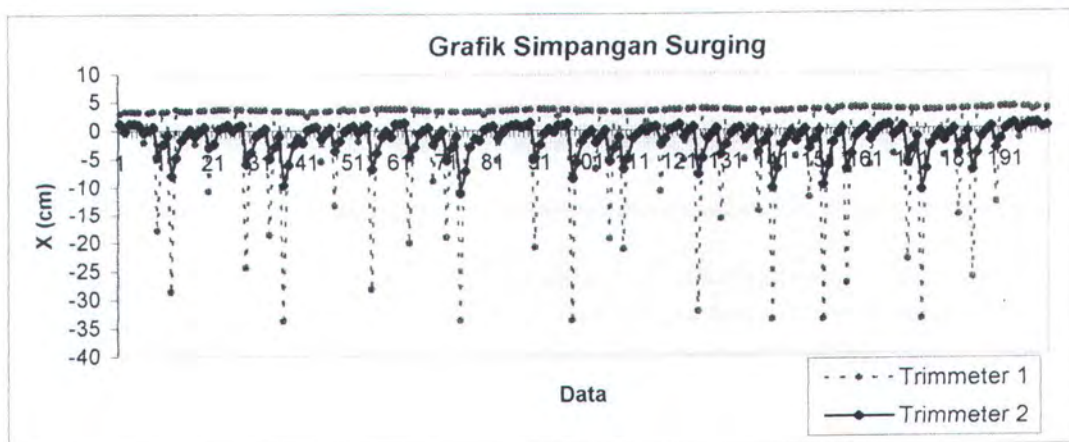
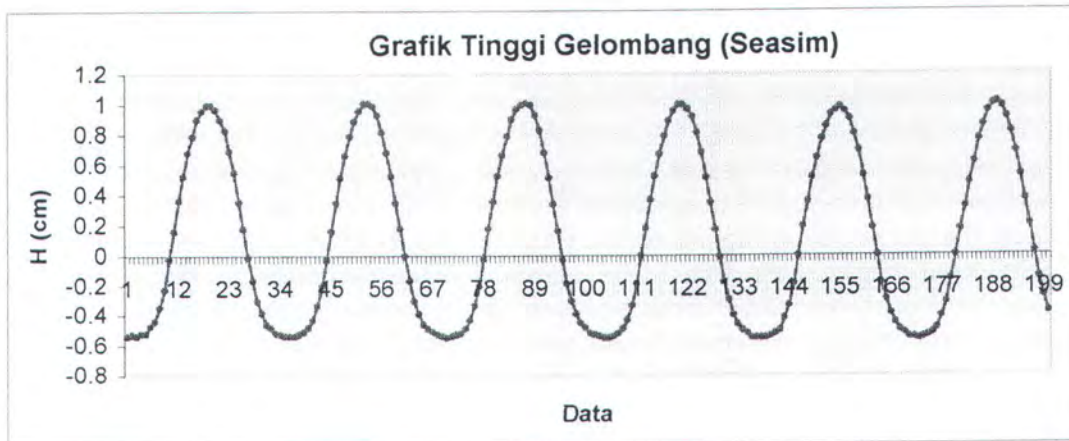
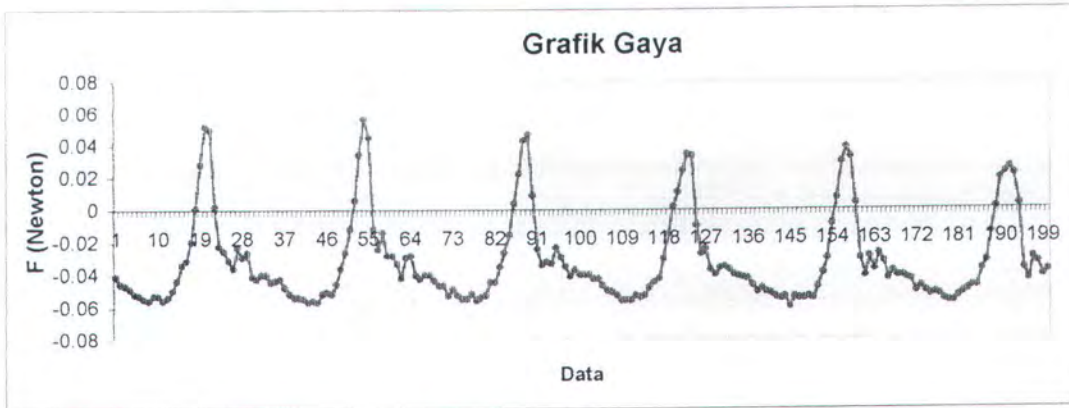



**Grafik Gaya, Simpangan, dan Tinggi Gelombang**  
 Kondisi Sarat 11 cm, Tinggi Gel. 2 cm, Periode 1.8 dt

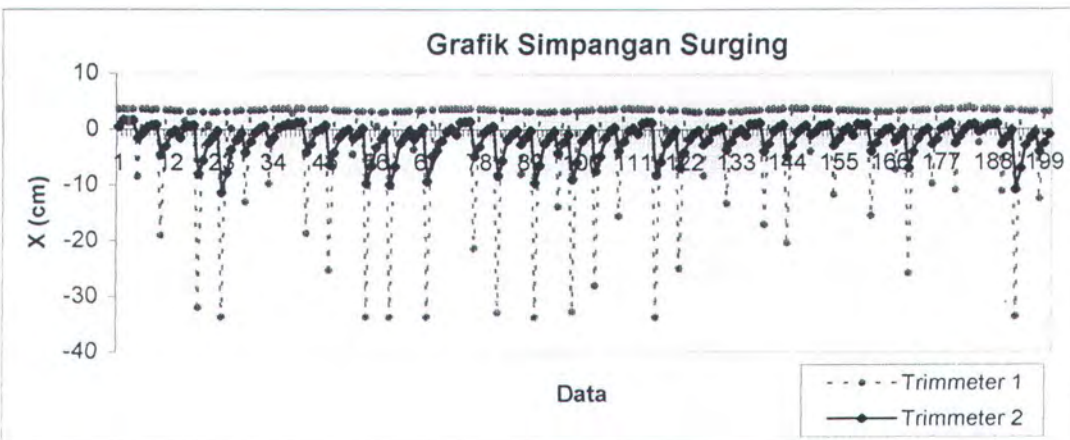
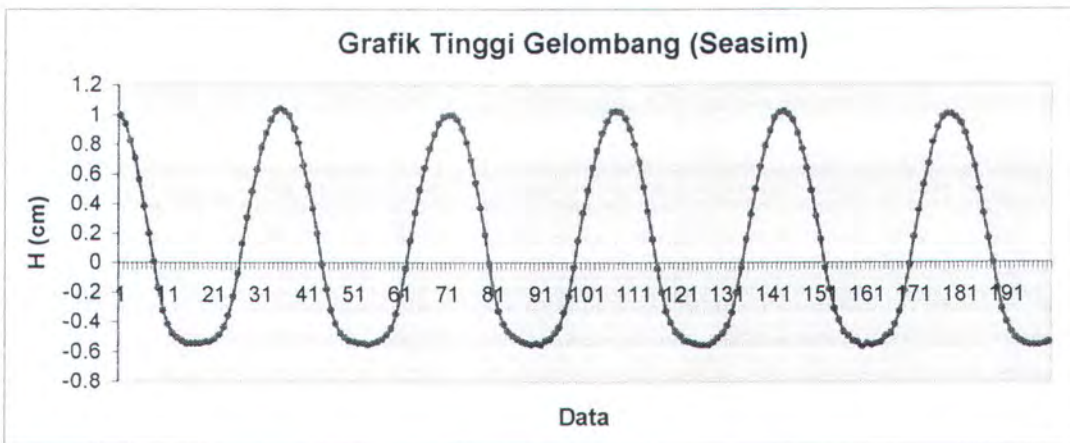
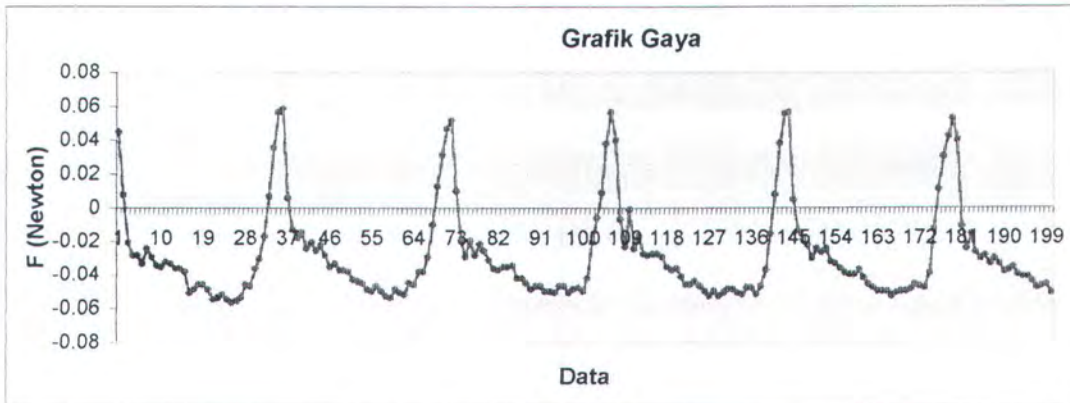



**Grafik Gaya, Simpangan, dan Tinggi Gelombang**  
 Kondisi Sarat 11 cm, Tinggi Gel. 2 cm, Periode 1.9 dt

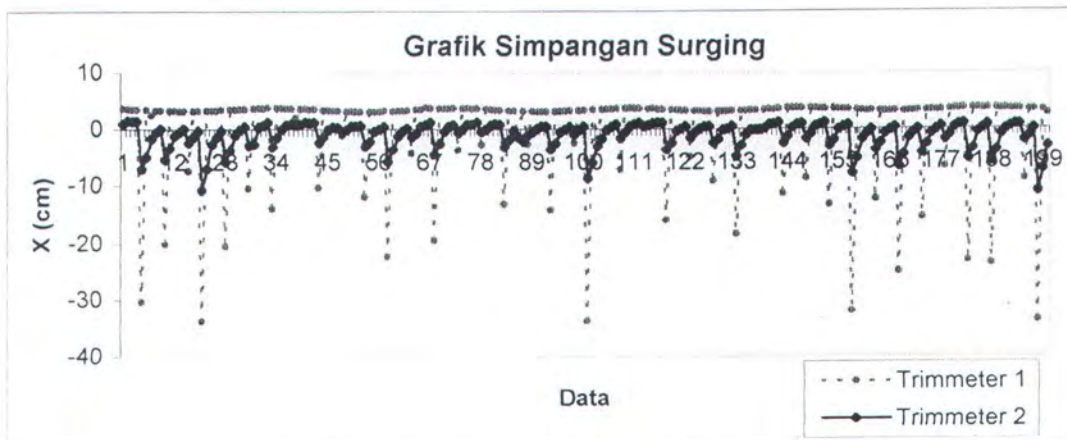
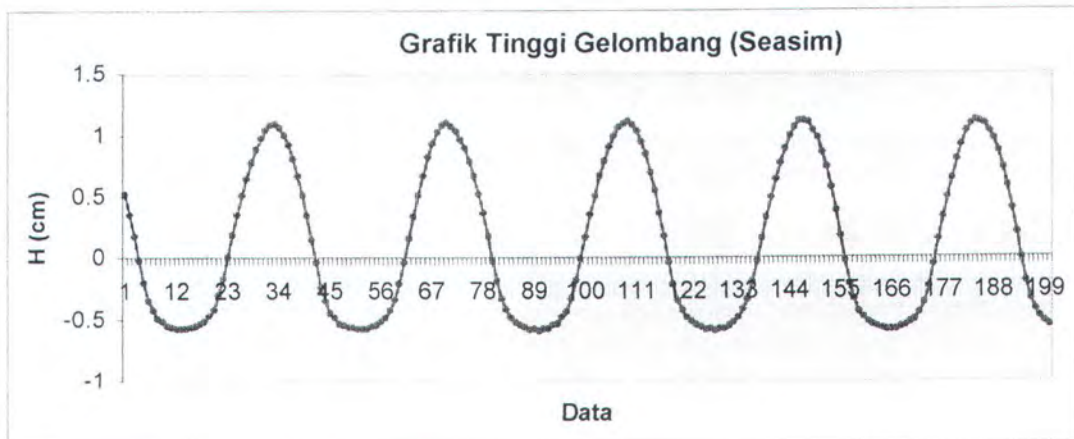
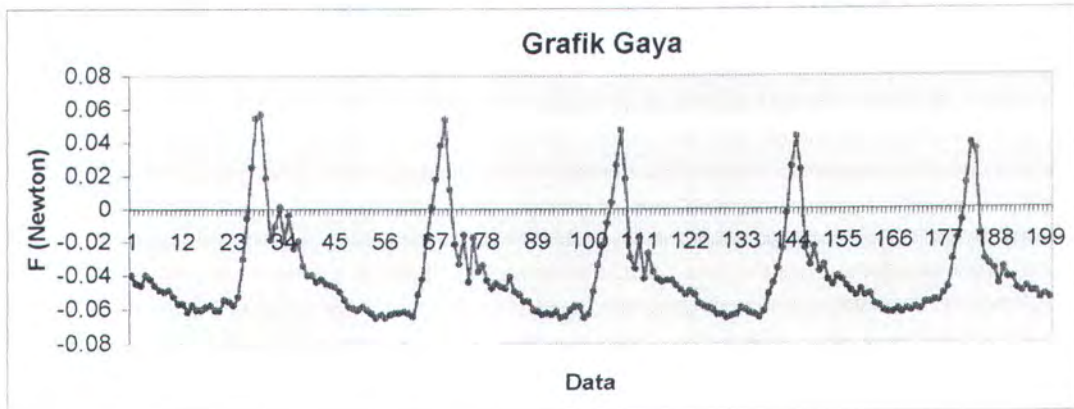



**Grafik Gaya, Simpangan, dan Tinggi Gelombang**  
**Kondisi Sarat 11 cm, Tinggi Gel. 2 cm, Periode 2.0 dt**

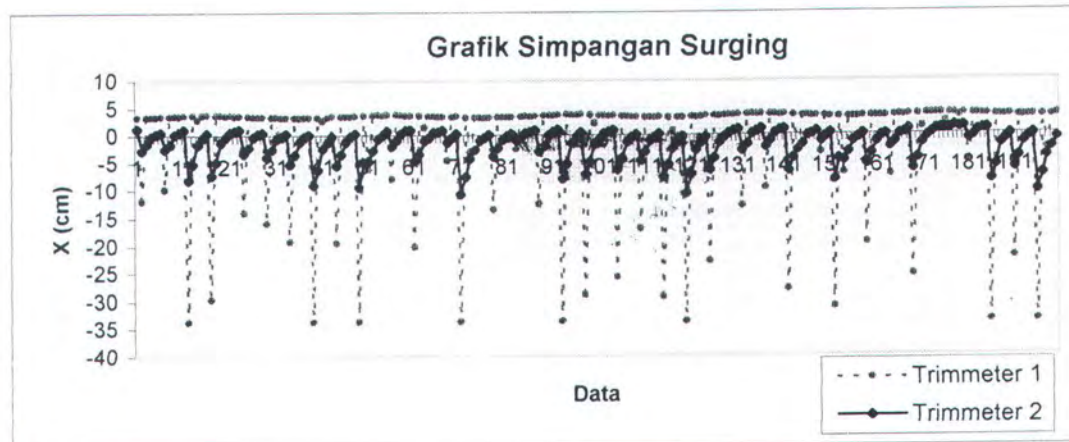
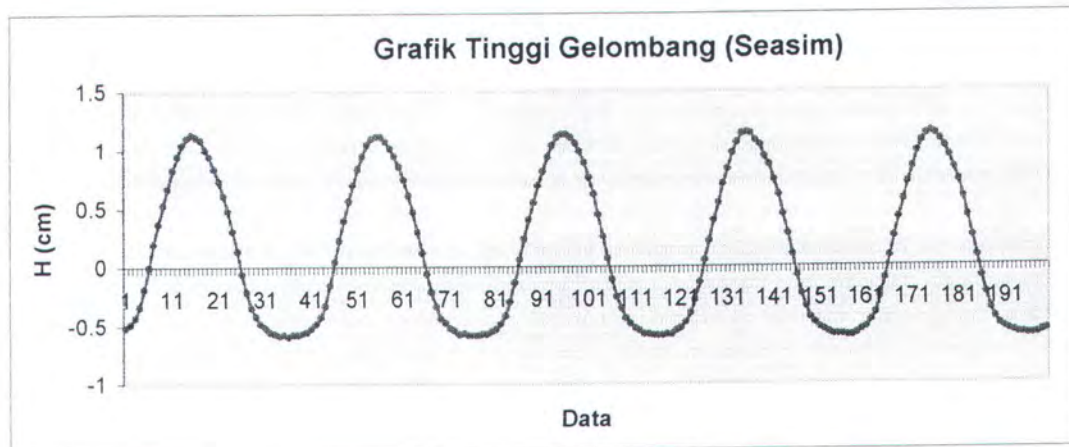
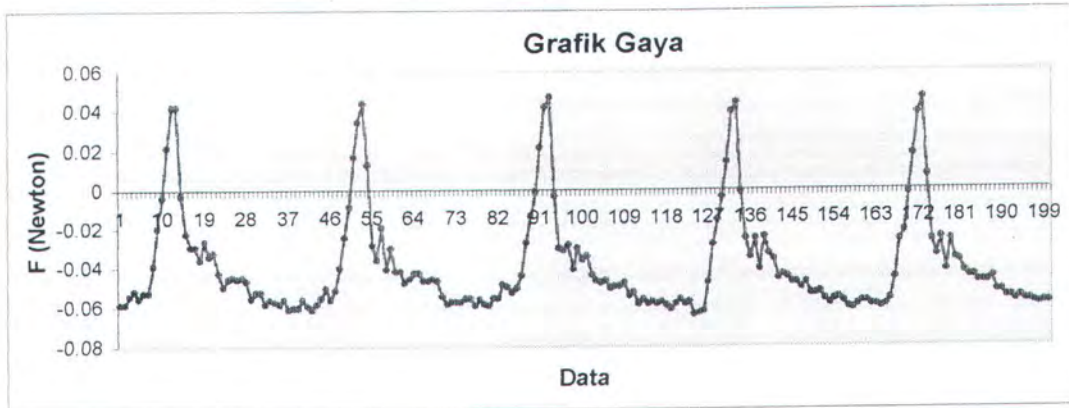



### Perhitungan Koefisien Radaman pada Kondisi Sarat 6.5 cm

Periode = 1.2 det Frekwensi = 5.2360

No.	Bn	Tn	Sn	$\omega^2 \times Bn / 2g$	$\beta$	Bn/Tn	A	bn	FS	Product	
1	0.1082	0.065	0.0048	0.1511	0.7	1.7	0.2471	40.9343	1	40.9343	
2	0.1082	0.065	0.0048	0.1511	0.7	1.7	0.2471	40.9343	4	163.7373	
3	0.1082	0.065	0.0048	0.1511	0.7	1.7	0.2471	40.9343	2	81.8687	
4	0.1082	0.065	0.0048	0.1511	0.7	1.7	0.2471	40.9343	4	163.7373	
5	0.1082	0.065	0.0048	0.1511	0.7	1.7	0.2471	40.9343	2	81.8687	
6	0.1082	0.065	0.0048	0.1511	0.7	1.7	0.2471	40.9343	4	163.7373	
7	0.1082	0.065	0.0048	0.1511	0.7	1.7	0.2471	40.9343	2	81.8687	
8	0.1082	0.065	0.0048	0.1511	0.7	1.7	0.2471	40.9343	4	163.7373	
9	0.1082	0.065	0.0048	0.1511	0.7	1.7	0.2471	40.9343	2	81.8687	
10	0.1082	0.065	0.0048	0.1511	0.7	1.7	0.2471	40.9343	4	163.7373	
11	0.1082	0.065	0.0048	0.1511	0.7	1.7	0.2471	40.9343	1	40.9343	
									Total	=	1228.0298
									Nz	=	40.1975
									b	=	5.4821

f = 0.1 Cz = 0.6819

Periode = 1.3 det Frekwensi = 4.8332

No.	Bn	Tn	Sn	$\omega^2 \times Bn / 2g$	$\beta$	Bn/Tn	A	bn	FS	Product	
1	0.1082	0.065	0.0048	0.1288	0.7	1.7	0.2125	38.4899	1	38.4899	
2	0.1082	0.065	0.0048	0.1288	0.7	1.7	0.2125	38.4899	4	153.9594	
3	0.1082	0.065	0.0048	0.1288	0.7	1.7	0.2125	38.4899	2	76.9797	
4	0.1082	0.065	0.0048	0.1288	0.7	1.7	0.2125	38.4899	4	153.9594	
5	0.1082	0.065	0.0048	0.1288	0.7	1.7	0.2125	38.4899	2	76.9797	
6	0.1082	0.065	0.0048	0.1288	0.7	1.7	0.2125	38.4899	4	153.9594	
7	0.1082	0.065	0.0048	0.1288	0.7	1.7	0.2125	38.4899	2	76.9797	
8	0.1082	0.065	0.0048	0.1288	0.7	1.7	0.2125	38.4899	4	153.9594	
9	0.1082	0.065	0.0048	0.1288	0.7	1.7	0.2125	38.4899	2	76.9797	
10	0.1082	0.065	0.0048	0.1288	0.7	1.7	0.2125	38.4899	4	153.9594	
11	0.1082	0.065	0.0048	0.1288	0.7	1.7	0.2125	38.4899	1	38.4899	
									Total	=	1154.6958
									Nz	=	37.7970
									b	=	4.6076

f = 0.1 Cz = 0.6095

Periode = 1.4 det Frekwensi = 4.4880

No.	Bn	Tn	Sn	$\omega^2 \times Bn / 2g$	$\beta$	Bn/Tn	A	bn	FS	Product	
1	0.1082	0.065	0.0048	0.1110	0.7	1.7	0.1954	40.6473	1	40.6473	
2	0.1082	0.065	0.0048	0.1110	0.7	1.7	0.1954	40.6473	4	162.5892	
3	0.1082	0.065	0.0048	0.1110	0.7	1.7	0.1954	40.6473	2	81.2946	
4	0.1082	0.065	0.0048	0.1110	0.7	1.7	0.1954	40.6473	4	162.5892	
5	0.1082	0.065	0.0048	0.1110	0.7	1.7	0.1954	40.6473	2	81.2946	
6	0.1082	0.065	0.0048	0.1110	0.7	1.7	0.1954	40.6473	4	162.5892	
7	0.1082	0.065	0.0048	0.1110	0.7	1.7	0.1954	40.6473	2	81.2946	
8	0.1082	0.065	0.0048	0.1110	0.7	1.7	0.1954	40.6473	4	162.5892	
9	0.1082	0.065	0.0048	0.1110	0.7	1.7	0.1954	40.6473	2	81.2946	
10	0.1082	0.065	0.0048	0.1110	0.7	1.7	0.1954	40.6473	4	162.5892	
11	0.1082	0.065	0.0048	0.1110	0.7	1.7	0.1954	40.6473	1	40.6473	
									Total	=	1219.4188
									Nz	=	39.9156
									b	=	4.3337

f = 0.1 Cz = 0.5429



### Perhitungan Koefisien Radaman pada Kondisi Sarat 6.5 cm

Periode = 1.5 det

Frekwensi = 4.1888

No.	Bn	Tn	Sn	$\omega^2 \times Bn / 2g$	$\beta$	Bn/Tn	A	bn	FS	Product			
1	0.108	0.065	0.0048	0.0967	0.7	1.7	0.1844	44.5240	1	44.5240			
2	0.108	0.065	0.0048	0.0967	0.7	1.7	0.1844	44.5240	4	178.0959			
3	0.108	0.065	0.0048	0.0967	0.7	1.7	0.1844	44.5240	2	89.0480			
4	0.108	0.065	0.0048	0.0967	0.7	1.7	0.1844	44.5240	4	178.0959			
5	0.108	0.065	0.0048	0.0967	0.7	1.7	0.1844	44.5240	2	89.0480			
6	0.108	0.065	0.0048	0.0967	0.7	1.7	0.1844	44.5240	4	178.0959			
7	0.108	0.065	0.0048	0.0967	0.7	1.7	0.1844	44.5240	2	89.0480			
8	0.108	0.065	0.0048	0.0967	0.7	1.7	0.1844	44.5240	4	178.0959			
9	0.108	0.065	0.0048	0.0967	0.7	1.7	0.1844	44.5240	2	89.0480			
10	0.108	0.065	0.0048	0.0967	0.7	1.7	0.1844	44.5240	4	178.0959			
11	0.108	0.065	0.0048	0.0967	0.7	1.7	0.1844	44.5240	1	44.5240			
									Total	=	1335.7195		
f = 0.1									Cz =	0.4838	Nz	=	43.7226
									b	=	4.2307		

Periode = 1.6 det

Frekwensi = 3.9270

No.	Bn	Tn	Sn	$\omega^2 \times Bn / 2g$	$\beta$	Bn/Tn	A	bn	FS	Product			
1	0.108	0.065	0.0048	0.0850	0.7	1.7	0.1669	44.2661	1	44.2661			
2	0.108	0.065	0.0048	0.0850	0.7	1.7	0.1669	44.2661	4	177.0643			
3	0.108	0.065	0.0048	0.0850	0.7	1.7	0.1669	44.2661	2	88.5322			
4	0.108	0.065	0.0048	0.0850	0.7	1.7	0.1669	44.2661	4	177.0643			
5	0.108	0.065	0.0048	0.0850	0.7	1.7	0.1669	44.2661	2	88.5322			
6	0.108	0.065	0.0048	0.0850	0.7	1.7	0.1669	44.2661	4	177.0643			
7	0.108	0.065	0.0048	0.0850	0.7	1.7	0.1669	44.2661	2	88.5322			
8	0.108	0.065	0.0048	0.0850	0.7	1.7	0.1669	44.2661	4	177.0643			
9	0.108	0.065	0.0048	0.0850	0.7	1.7	0.1669	44.2661	2	88.5322			
10	0.108	0.065	0.0048	0.0850	0.7	1.7	0.1669	44.2661	4	177.0643			
11	0.108	0.065	0.0048	0.0850	0.7	1.7	0.1669	44.2661	1	44.2661			
									Total	=	1327.9823		
f = 0.1									Cz =	0.4362	Nz	=	43.4693
									b	=	3.7922		

Periode = 1.7 det

Frekwensi = 3.6960

No.	Bn	Tn	Sn	$\omega^2 \times Bn / 2g$	$\beta$	Bn/Tn	A	bn	FS	Product			
1	0.108	0.065	0.0048	0.0753	0.7	1.7	0.1494	42.5448	1	42.5448			
2	0.108	0.065	0.0048	0.0753	0.7	1.7	0.1494	42.5448	4	170.1792			
3	0.108	0.065	0.0048	0.0753	0.7	1.7	0.1494	42.5448	2	85.0896			
4	0.108	0.065	0.0048	0.0753	0.7	1.7	0.1494	42.5448	4	170.1792			
5	0.108	0.065	0.0048	0.0753	0.7	1.7	0.1494	42.5448	2	85.0896			
6	0.108	0.065	0.0048	0.0753	0.7	1.7	0.1494	42.5448	4	170.1792			
7	0.108	0.065	0.0048	0.0753	0.7	1.7	0.1494	42.5448	2	85.0896			
8	0.108	0.065	0.0048	0.0753	0.7	1.7	0.1494	42.5448	4	170.1792			
9	0.108	0.065	0.0048	0.0753	0.7	1.7	0.1494	42.5448	2	85.0896			
10	0.108	0.065	0.0048	0.0753	0.7	1.7	0.1494	42.5448	4	170.1792			
11	0.108	0.065	0.0048	0.0753	0.7	1.7	0.1494	42.5448	1	42.5448			
									Total	=	1276.3437		
f = 0.1									Cz =	0.3714	Nz	=	41.7790
									b	=	3.1036		



### Perhitungan Koefisien Radaman pada Kondisi Sarat 6.5 cm

Periode = 1.8 det Frekwensi = 3.4907

No.	Bn	Tn	Sn	$\omega^2 \times Bn / 2g$	$\beta$	Bn/Tn	A	bn	FS	Product			
1	0.108	0.065	0.0048	0.0672	0.7	1.7	0.1353	41.4201	1	41.4201			
2	0.108	0.065	0.0048	0.0672	0.7	1.7	0.1353	41.4201	4	165.6805			
3	0.108	0.065	0.0048	0.0672	0.7	1.7	0.1353	41.4201	2	82.8403			
4	0.108	0.065	0.0048	0.0672	0.7	1.7	0.1353	41.4201	4	165.6805			
5	0.108	0.065	0.0048	0.0672	0.7	1.7	0.1353	41.4201	2	82.8403			
6	0.108	0.065	0.0048	0.0672	0.7	1.7	0.1353	41.4201	4	165.6805			
7	0.108	0.065	0.0048	0.0672	0.7	1.7	0.1353	41.4201	2	82.8403			
8	0.108	0.065	0.0048	0.0672	0.7	1.7	0.1353	41.4201	4	165.6805			
9	0.108	0.065	0.0048	0.0672	0.7	1.7	0.1353	41.4201	2	82.8403			
10	0.108	0.065	0.0048	0.0672	0.7	1.7	0.1353	41.4201	4	165.6805			
11	0.108	0.065	0.0048	0.0672	0.7	1.7	0.1353	41.4201	1	41.4201			
									Total	=	1242.6041		
f = 0.1									Cz =	0.3238	Nz	=	40.6746
									b	=	2.6342		

Periode = 1.9 det Frekwensi = 3.3069

No.	Bn	Tn	Sn	$\omega^2 \times Bn / 2g$	$\beta$	Bn/Tn	A	bn	FS	Product			
1	0.108	0.065	0.0048	0.0603	0.7	1.7	0.1226	39.9982	1	39.9982			
2	0.108	0.065	0.0048	0.0603	0.7	1.7	0.1226	39.9982	4	159.9927			
3	0.108	0.065	0.0048	0.0603	0.7	1.7	0.1226	39.9982	2	79.9963			
4	0.108	0.065	0.0048	0.0603	0.7	1.7	0.1226	39.9982	4	159.9927			
5	0.108	0.065	0.0048	0.0603	0.7	1.7	0.1226	39.9982	2	79.9963			
6	0.108	0.065	0.0048	0.0603	0.7	1.7	0.1226	39.9982	4	159.9927			
7	0.108	0.065	0.0048	0.0603	0.7	1.7	0.1226	39.9982	2	79.9963			
8	0.108	0.065	0.0048	0.0603	0.7	1.7	0.1226	39.9982	4	159.9927			
9	0.108	0.065	0.0048	0.0603	0.7	1.7	0.1226	39.9982	2	79.9963			
10	0.108	0.065	0.0048	0.0603	0.7	1.7	0.1226	39.9982	4	159.9927			
11	0.108	0.065	0.0048	0.0603	0.7	1.7	0.1226	39.9982	1	39.9982			
									Total	=	1199.9452		
f = 0.1									Cz =	0.2705	Nz	=	39.2782
									b	=	2.1248		

Periode = 2.0 det Frekwensi = 3.1416

No.	Bn	Tn	Sn	$\omega^2 \times Bn / 2g$	$\beta$	Bn/Tn	A	bn	FS	Product			
1	0.108	0.065	0.0048	0.0544	0.7	1.7	0.1141	40.4073	1	40.4073			
2	0.108	0.065	0.0048	0.0544	0.7	1.7	0.1141	40.4073	4	161.6291			
3	0.108	0.065	0.0048	0.0544	0.7	1.7	0.1141	40.4073	2	80.8146			
4	0.108	0.065	0.0048	0.0544	0.7	1.7	0.1141	40.4073	4	161.6291			
5	0.108	0.065	0.0048	0.0544	0.7	1.7	0.1141	40.4073	2	80.8146			
6	0.108	0.065	0.0048	0.0544	0.7	1.7	0.1141	40.4073	4	161.6291			
7	0.108	0.065	0.0048	0.0544	0.7	1.7	0.1141	40.4073	2	80.8146			
8	0.108	0.065	0.0048	0.0544	0.7	1.7	0.1141	40.4073	4	161.6291			
9	0.108	0.065	0.0048	0.0544	0.7	1.7	0.1141	40.4073	2	80.8146			
10	0.108	0.065	0.0048	0.0544	0.7	1.7	0.1141	40.4073	4	161.6291			
11	0.108	0.065	0.0048	0.0544	0.7	1.7	0.1141	40.4073	1	40.4073			
									Total	=	1212.2186		
f = 0.1									Cz =	0.2371	Nz	=	39.6800
									b	=	1.8819		



### Perhitungan Koefisien Radaman pada Kondisi Sarat 11.0 cm

Periode = 1.2 det

Frekwensi = 5.2360

No.	Bn	Tn	Sn	$\omega^2 \times Bn/2g$	$\beta$	Bn/Tn	A	bn	FS	Product	
1	0.0	0.11	0.0095	0.0000	0	0.000	0.0000	0.0000	1	0.0000	
2	0.0785	0.11	0.0095	0.1097	1	0.714	0.1394	13.0319	4	52.1275	
3	0.0	0.11	0.0095	0.0000	0	0.000	0.0000	0.0000	2	0.0000	
4	0.0	0.11	0.0095	0.0000	0	0.000	0.0000	0.0000	4	0.0000	
5	0.0	0.11	0.0095	0.0000	0	0.000	0.0000	0.0000	2	0.0000	
6	0.0800	0.11	0.0095	0.1118	1	0.727	0.1471	14.5035	4	58.0140	
7	0.0	0.11	0.0095	0.0000	0	0.000	0.0000	0.0000	2	0.0000	
8	0.0	0.11	0.0095	0.0000	0	0.000	0.0000	0.0000	4	0.0000	
9	0.0	0.11	0.0095	0.0000	0	0.000	0.0000	0.0000	2	0.0000	
10	0.0785	0.11	0.0095	0.1097	1	0.714	0.1394	13.0319	4	52.1275	
11	0.0	0.11	0.0095	0.0000	0	0.000	0.0000	0.0000	1	0.0000	
									Total	=	162.2691
f = 0.1									Cz =	0.6819	
									Nz	=	5.3116
									b	=	0.7244

Periode = 1.3 det

Frekwensi = 4.8332

No.	Bn	Tn	Sn	$\omega^2 \times Bn/2g$	$\beta$	Bn/Tn	A	bn	FS	Product	
1	0.0	0.11	0.0095	0.0000	0	0.000	0.0000	0.0000	1	0.0000	
2	0.0785	0.11	0.0095	0.0935	1	0.714	0.1297	14.3348	4	57.3392	
3	0.0	0.11	0.0095	0.0000	0	0.000	0.0000	0.0000	2	0.0000	
4	0.0	0.11	0.0095	0.0000	0	0.000	0.0000	0.0000	4	0.0000	
5	0.0	0.11	0.0095	0.0000	0	0.000	0.0000	0.0000	2	0.0000	
6	0.0800	0.11	0.0095	0.0952	1	0.727	0.1320	14.8523	4	59.4090	
7	0.0	0.11	0.0095	0.0000	0	0.000	0.0000	0.0000	2	0.0000	
8	0.0	0.11	0.0095	0.0000	0	0.000	0.0000	0.0000	4	0.0000	
9	0.0	0.11	0.0095	0.0000	0	0.000	0.0000	0.0000	2	0.0000	
10	0.0785	0.11	0.0095	0.0935	1	0.714	0.1297	14.3348	4	57.3392	
11	0.0	0.11	0.0095	0.0000	0	0.000	0.0000	0.0000	1	0.0000	
									Total	=	174.0875
f = 0.1									Cz =	0.6095	
									Nz	=	5.6985
									b	=	0.6947

Periode = 1.4 det

Frekwensi = 4.4880

No.	Bn	Tn	Sn	$\omega^2 \times Bn/2g$	$\beta$	Bn/Tn	A	bn	FS	Product	
1	0.0	0.11	0.0095	0.0000	0	0.000	0.0000	0.0000	1	0.0000	
2	0.0785	0.11	0.0095	0.0806	1	0.714	0.1198	15.2757	4	61.1027	
3	0.0	0.11	0.0095	0.0000	0	0.000	0.0000	0.0000	2	0.0000	
4	0.0	0.11	0.0095	0.0000	0	0.000	0.0000	0.0000	4	0.0000	
5	0.0	0.11	0.0095	0.0000	0	0.000	0.0000	0.0000	2	0.0000	
6	0.0800	0.11	0.0095	0.0821	1	0.727	0.1219	15.8139	4	63.2557	
7	0.0	0.11	0.0095	0.0000	0	0.000	0.0000	0.0000	2	0.0000	
8	0.0	0.11	0.0095	0.0000	0	0.000	0.0000	0.0000	4	0.0000	
9	0.0	0.11	0.0095	0.0000	0	0.000	0.0000	0.0000	2	0.0000	
10	0.0785	0.11	0.0095	0.0806	1	0.714	0.1198	15.2757	4	61.1027	
11	0.0	0.11	0.0095	0.0000	0	0.000	0.0000	0.0000	1	0.0000	
									Total	=	185.4610
f = 0.1									Cz =	0.5429	
									Nz	=	6.0708
									b	=	0.6591



### Perhitungan Koefisien Radaman pada Kondisi Sarat 11.0 cm

Periode = 1.5 det Frekwensi = 4.1888

No.	Bn	Tn	Sn	$\omega^2 \times Bn / 2g$	$\beta$	Bn/Tn	A	bn	FS	Product	
1	0.0	0.11	0.0095	0.0000	0	0.000	0.0000	0.0000	1	0.0000	
2	0.0785	0.11	0.0095	0.0702	1	0.714	0.1091	15.5766	4	62.3064	
3	0.0	0.11	0.0095	0.0000	0	0.000	0.0000	0.0000	2	0.0000	
4	0.0	0.11	0.0095	0.0000	0	0.000	0.0000	0.0000	4	0.0000	
5	0.0	0.11	0.0095	0.0000	0	0.000	0.0000	0.0000	2	0.0000	
6	0.0800	0.11	0.0095	0.0715	1	0.727	0.1124	16.5346	4	66.1386	
7	0.0	0.11	0.0095	0.0000	0	0.000	0.0000	0.0000	2	0.0000	
8	0.0	0.11	0.0095	0.0000	0	0.000	0.0000	0.0000	4	0.0000	
9	0.0	0.11	0.0095	0.0000	0	0.000	0.0000	0.0000	2	0.0000	
10	0.0785	0.11	0.0095	0.0702	1	0.714	0.1091	15.5766	4	62.3064	
11	0.0	0.11	0.0095	0.0000	0	0.000	0.0000	0.0000	1	0.0000	
									Total	=	190.7513
									Nz	=	6.2439
									b	=	0.6042

f = 0.1 Cz = 0.4838

Periode = 1.6 det Frekwensi = 3.9270

No.	Bn	Tn	Sn	$\omega^2 \times Bn / 2g$	$\beta$	Bn/Tn	A	bn	FS	Product	
1	0.0	0.11	0.0095	0.0000	0	0.000	0.0000	0.0000	1	0.0000	
2	0.0785	0.11	0.0095	0.0617	1	0.714	0.0982	15.3233	4	61.2932	
3	0.0	0.11	0.0095	0.0000	0	0.000	0.0000	0.0000	2	0.0000	
4	0.0	0.11	0.0095	0.0000	0	0.000	0.0000	0.0000	4	0.0000	
5	0.0	0.11	0.0095	0.0000	0	0.000	0.0000	0.0000	2	0.0000	
6	0.0800	0.11	0.0095	0.0629	1	0.727	0.1014	16.3481	4	65.3923	
7	0.0	0.11	0.0095	0.0000	0	0.000	0.0000	0.0000	2	0.0000	
8	0.0	0.11	0.0095	0.0000	0	0.000	0.0000	0.0000	4	0.0000	
9	0.0	0.11	0.0095	0.0000	0	0.000	0.0000	0.0000	2	0.0000	
10	0.0785	0.11	0.0095	0.0617	1	0.714	0.0982	15.3233	4	61.2932	
11	0.0	0.11	0.0095	0.0000	0	0.000	0.0000	0.0000	1	0.0000	
									Total	=	187.9788
									Nz	=	6.1532
									b	=	0.5368

f = 0.1 Cz = 0.4362

Periode = 1.7 det Frekwensi = 3.6960

No.	Bn	Tn	Sn	$\omega^2 \times Bn / 2g$	$\beta$	Bn/Tn	A	bn	FS	Product	
1	0.0	0.11	0.0095	0.0000	0	0.000	0.0000	0.0000	1	0.0000	
2	0.0785	0.11	0.0095	0.0547	1	0.714	0.0936	16.7159	4	66.8637	
3	0.0	0.11	0.0095	0.0000	0	0.000	0.0000	0.0000	2	0.0000	
4	0.0	0.11	0.0095	0.0000	0	0.000	0.0000	0.0000	4	0.0000	
5	0.0	0.11	0.0095	0.0000	0	0.000	0.0000	0.0000	2	0.0000	
6	0.0800	0.11	0.0095	0.0557	1	0.727	0.0969	17.8897	4	71.5590	
7	0.0	0.11	0.0095	0.0000	0	0.000	0.0000	0.0000	2	0.0000	
8	0.0	0.11	0.0095	0.0000	0	0.000	0.0000	0.0000	4	0.0000	
9	0.0	0.11	0.0095	0.0000	0	0.000	0.0000	0.0000	2	0.0000	
10	0.0785	0.11	0.0095	0.0547	1	0.714	0.0936	16.7159	4	66.8637	
11	0.0	0.11	0.0095	0.0000	0	0.000	0.0000	0.0000	1	0.0000	
									Total	=	205.2864
									Nz	=	6.7197
									b	=	0.4992

f = 0.1 Cz = 0.3714



### Perhitungan Koefisien Radaman pada Kondisi Sarat 11.0 cm

Periode = 1.8 det

Frekwensi = 3.4907

No.	Bn	Tn	Sn	$\omega^2 \times Bn / 2g$	$\beta$	Bn/Tn	A	bn	FS	Product	
1	0.0	0.11	0.0095	0.0000	0	0.000	0.0000	0.0000	1	0.0000	
2	0.0785	0.11	0.0095	0.0488	1	0.714	0.0744	12.5215	4	50.0862	
3	0.0	0.11	0.0095	0.0000	0	0.000	0.0000	0.0000	2	0.0000	
4	0.0	0.11	0.0095	0.0000	0	0.000	0.0000	0.0000	4	0.0000	
5	0.0	0.11	0.0095	0.0000	0	0.000	0.0000	0.0000	2	0.0000	
6	0.0800	0.11	0.0095	0.0497	1	0.727	0.0758	13.0058	4	52.0233	
7	0.0	0.11	0.0095	0.0000	0	0.000	0.0000	0.0000	2	0.0000	
8	0.0	0.11	0.0095	0.0000	0	0.000	0.0000	0.0000	4	0.0000	
9	0.0	0.11	0.0095	0.0000	0	0.000	0.0000	0.0000	2	0.0000	
10	0.0785	0.11	0.0095	0.0488	1	0.714	0.0744	12.5215	4	50.0862	
11	0.0	0.11	0.0095	0.0000	0	0.000	0.0000	0.0000	1	0.0000	
Total =										152.1957	
f = 0.1      Cz = 0.3238										Nz =	4.9819
										b =	0.3226

Periode = 1.9 det

Frekwensi = 3.3069

No.	Bn	Tn	Sn	$\omega^2 \times Bn / 2g$	$\beta$	Bn/Tn	A	bn	FS	Product	
1	0.0	0.11	0.0095	0.0000	0	0.000	0.0000	0.0000	1	0.0000	
2	0.0785	0.11	0.0095	0.0438	1	0.714	0.0729	14.1317	4	56.5269	
3	0.0	0.11	0.0095	0.0000	0	0.000	0.0000	0.0000	2	0.0000	
4	0.0	0.11	0.0095	0.0000	0	0.000	0.0000	0.0000	4	0.0000	
5	0.0	0.11	0.0095	0.0000	0	0.000	0.0000	0.0000	2	0.0000	
6	0.0800	0.11	0.0095	0.0446	1	0.727	0.0743	14.6897	4	58.7587	
7	0.0	0.11	0.0095	0.0000	0	0.000	0.0000	0.0000	2	0.0000	
8	0.0	0.11	0.0095	0.0000	0	0.000	0.0000	0.0000	4	0.0000	
9	0.0	0.11	0.0095	0.0000	0	0.000	0.0000	0.0000	2	0.0000	
10	0.0785	0.11	0.0095	0.0438	1	0.714	0.0729	14.1317	4	56.5269	
11	0.0	0.11	0.0095	0.0000	0	0.000	0.0000	0.0000	1	0.0000	
Total =										171.8126	
f = 0.1      Cz = 0.2705										Nz =	5.6240
										b =	0.3042

Periode = 2.0 det

Frekwensi = 3.1416

No.	Bn	Tn	Sn	$\omega^2 \times Bn / 2g$	$\beta$	Bn/Tn	A	bn	FS	Product	
1	0.0	0.11	0.0095	0.0000	0	0.000	0.0000	0.0000	1	0.0000	
2	0.0785	0.11	0.0095	0.0395	1	0.714	0.0627	12.2148	4	48.8591	
3	0.0	0.11	0.0095	0.0000	0	0.000	0.0000	0.0000	2	0.0000	
4	0.0	0.11	0.0095	0.0000	0	0.000	0.0000	0.0000	4	0.0000	
5	0.0	0.11	0.0095	0.0000	0	0.000	0.0000	0.0000	2	0.0000	
6	0.0800	0.11	0.0095	0.0402	1	0.727	0.0735	16.7846	4	67.1383	
7	0.0	0.11	0.0095	0.0000	0	0.000	0.0000	0.0000	2	0.0000	
8	0.0	0.11	0.0095	0.0000	0	0.000	0.0000	0.0000	4	0.0000	
9	0.0	0.11	0.0095	0.0000	0	0.000	0.0000	0.0000	2	0.0000	
10	0.0785	0.11	0.0095	0.0395	1	0.714	0.0627	12.2148	4	48.8591	
11	0.0	0.11	0.0095	0.0000	0	0.000	0.0000	0.0000	1	0.0000	
Total =										164.8566	
f = 0.1      Cz = 0.2371										Nz =	5.3963
										b =	0.2559



### Perhitungan Koefisien Radaman pada Kondisi Sarat 22.4 cm

Periode = 1.2 det

Frekwensi = 5.2360

No.	Bn	Tn	Sn	$\omega^2 \times Bn / 2g$	$\beta$	Bn/Tn	A	bn	FS	Product			
1	0.0	0.224	0.0095	0.0000	0	0.000	0.0000	0.0000	1	0.0000			
2	0.0785	0.224	0.0185	0.1097	1	0.350	0.1011	6.8545	4	27.4178			
3	0.0	0.224	0.0095	0.0000	0	0.000	0.0000	0.0000	2	0.0000			
4	0.0	0.224	0.0095	0.0000	0	0.000	0.0000	0.0000	4	0.0000			
5	0.0	0.224	0.0095	0.0000	0	0.000	0.0000	0.0000	2	0.0000			
6	0.0800	0.224	0.0186	0.1118	1	0.357	0.1051	7.4080	4	29.6320			
7	0.0	0.224	0.0095	0.0000	0	0.000	0.0000	0.0000	2	0.0000			
8	0.0	0.224	0.0095	0.0000	0	0.000	0.0000	0.0000	4	0.0000			
9	0.0	0.224	0.0095	0.0000	0	0.000	0.0000	0.0000	2	0.0000			
10	0.0785	0.224	0.0185	0.1097	1	0.350	0.1011	6.8545	4	27.4178			
11	0.0	0.224	0.0095	0.0000	0	0.000	0.0000	0.0000	1	0.0000			
									Total	=	84.4677		
f = 0.1									Cz =	0.6819	Nz	=	2.7649
									b	=	0.3771		

Periode = 1.3 det

Frekwensi = 4.8332

No.	Bn	Tn	Sn	$\omega^2 \times Bn / 2g$	$\beta$	Bn/Tn	A	bn	FS	Product			
1	0.0	0.224	0.0095	0.0000	0	0.000	0.0000	0.0000	1	0.0000			
2	0.0785	0.224	0.0185	0.0935	1	0.350	0.0914	7.1183	4	28.4733			
3	0.0	0.224	0.0095	0.0000	0	0.000	0.0000	0.0000	2	0.0000			
4	0.0	0.224	0.0095	0.0000	0	0.000	0.0000	0.0000	4	0.0000			
5	0.0	0.224	0.0095	0.0000	0	0.000	0.0000	0.0000	2	0.0000			
6	0.0800	0.224	0.0186	0.0952	1	0.357	0.0952	7.7251	4	30.9003			
7	0.0	0.224	0.0095	0.0000	0	0.000	0.0000	0.0000	2	0.0000			
8	0.0	0.224	0.0095	0.0000	0	0.000	0.0000	0.0000	4	0.0000			
9	0.0	0.224	0.0095	0.0000	0	0.000	0.0000	0.0000	2	0.0000			
10	0.0785	0.224	0.0185	0.0935	1	0.350	0.0914	7.1183	4	28.4733			
11	0.0	0.224	0.0095	0.0000	0	0.000	0.0000	0.0000	1	0.0000			
									Total	=	87.8469		
f = 0.1									Cz =	0.6095	Nz	=	2.8755
									b	=	0.3505		

Periode = 1.4 det

Frekwensi = 4.4880

No.	Bn	Tn	Sn	$\omega^2 \times Bn / 2g$	$\beta$	Bn/Tn	A	bn	FS	Product			
1	0.0	0.224	0.0095	0.0000	0	0.000	0.0000	0.0000	1	0.0000			
2	0.0785	0.224	0.0185	0.0806	1	0.350	0.0875	8.1508	4	32.6031			
3	0.0	0.224	0.0095	0.0000	0	0.000	0.0000	0.0000	2	0.0000			
4	0.0	0.224	0.0095	0.0000	0	0.000	0.0000	0.0000	4	0.0000			
5	0.0	0.224	0.0095	0.0000	0	0.000	0.0000	0.0000	2	0.0000			
6	0.0800	0.224	0.0186	0.0821	1	0.357	0.0912	8.8605	4	35.4420			
7	0.0	0.224	0.0095	0.0000	0	0.000	0.0000	0.0000	2	0.0000			
8	0.0	0.224	0.0095	0.0000	0	0.000	0.0000	0.0000	4	0.0000			
9	0.0	0.224	0.0095	0.0000	0	0.000	0.0000	0.0000	2	0.0000			
10	0.0785	0.224	0.0185	0.0806	1	0.350	0.0875	8.1508	4	32.6031			
11	0.0	0.224	0.0095	0.0000	0	0.000	0.0000	0.0000	1	0.0000			
									Total	=	100.6481		
f = 0.1									Cz =	0.5429	Nz	=	3.2945
									b	=	0.3577		



### Perhitungan Koefisien Radaman pada Kondisi Sarat 22.4 cm

Periode = 1.5 det

Frekwensi = 4.1888

No.	Bn	Tn	Sn	$\omega^2 \times Bn / 2g$	$\beta$	Bn/Tn	A	bn	FS	Product			
1	0.0	0.224	0.0095	0.0000	0	0.000	0.0000	0.0000	1	0.0000			
2	0.0785	0.224	0.0185	0.0702	1	0.350	0.0778	7.9213	4	31.6850			
3	0.0	0.224	0.0095	0.0000	0	0.000	0.0000	0.0000	2	0.0000			
4	0.0	0.224	0.0095	0.0000	0	0.000	0.0000	0.0000	4	0.0000			
5	0.0	0.224	0.0095	0.0000	0	0.000	0.0000	0.0000	2	0.0000			
6	0.0800	0.224	0.0186	0.0715	1	0.357	0.0833	9.0851	4	36.3405			
7	0.0	0.224	0.0095	0.0000	0	0.000	0.0000	0.0000	2	0.0000			
8	0.0	0.224	0.0095	0.0000	0	0.000	0.0000	0.0000	4	0.0000			
9	0.0	0.224	0.0095	0.0000	0	0.000	0.0000	0.0000	2	0.0000			
10	0.0785	0.224	0.0185	0.0702	1	0.350	0.0778	7.9213	4	31.6850			
11	0.0	0.224	0.0095	0.0000	0	0.000	0.0000	0.0000	1	0.0000			
									Total	=	99.7106		
f = 0.1									Cz =	0.4838	Nz	=	3.2639
									b	=	0.3158		

Periode = 1.6 det

Frekwensi = 3.9270

No.	Bn	Tn	Sn	$\omega^2 \times Bn / 2g$	$\beta$	Bn/Tn	A	bn	FS	Product			
1	0.0	0.224	0.0095	0.0000	0	0.000	0.0000	0.0000	1	0.0000			
2	0.0785	0.224	0.0185	0.0617	1	0.350	0.0719	8.2243	4	32.8972			
3	0.0	0.224	0.0095	0.0000	0	0.000	0.0000	0.0000	2	0.0000			
4	0.0	0.224	0.0095	0.0000	0	0.000	0.0000	0.0000	4	0.0000			
5	0.0	0.224	0.0095	0.0000	0	0.000	0.0000	0.0000	2	0.0000			
6	0.0800	0.224	0.0186	0.0629	1	0.357	0.0774	9.5085	4	38.0341			
7	0.0	0.224	0.0095	0.0000	0	0.000	0.0000	0.0000	2	0.0000			
8	0.0	0.224	0.0095	0.0000	0	0.000	0.0000	0.0000	4	0.0000			
9	0.0	0.224	0.0095	0.0000	0	0.000	0.0000	0.0000	2	0.0000			
10	0.0785	0.224	0.0185	0.0617	1	0.350	0.0719	8.2243	4	32.8972			
11	0.0	0.224	0.0095	0.0000	0	0.000	0.0000	0.0000	1	0.0000			
									Total	=	103.8285		
f = 0.1									Cz =	0.4362	Nz	=	3.3987
									b	=	0.2965		

Periode = 1.7 det

Frekwensi = 3.6960

No.	Bn	Tn	Sn	$\omega^2 \times Bn / 2g$	$\beta$	Bn/Tn	A	bn	FS	Product			
1	0.0	0.224	0.0095	0.0000	0	0.000	0.0000	0.0000	1	0.0000			
2	0.0785	0.224	0.0185	0.0547	1	0.350	0.0681	8.8294	4	35.3174			
3	0.0	0.224	0.0095	0.0000	0	0.000	0.0000	0.0000	2	0.0000			
4	0.0	0.224	0.0095	0.0000	0	0.000	0.0000	0.0000	4	0.0000			
5	0.0	0.224	0.0095	0.0000	0	0.000	0.0000	0.0000	2	0.0000			
6	0.0800	0.224	0.0186	0.0557	1	0.357	0.0714	9.7172	4	38.8688			
7	0.0	0.224	0.0095	0.0000	0	0.000	0.0000	0.0000	2	0.0000			
8	0.0	0.224	0.0095	0.0000	0	0.000	0.0000	0.0000	4	0.0000			
9	0.0	0.224	0.0095	0.0000	0	0.000	0.0000	0.0000	2	0.0000			
10	0.0785	0.224	0.0185	0.0547	1	0.350	0.0681	8.8294	4	35.3174			
11	0.0	0.224	0.0095	0.0000	0	0.000	0.0000	0.0000	1	0.0000			
									Total	=	109.5037		
f = 0.1									Cz =	0.3714	Nz	=	3.5844
									b	=	0.2663		



### Perhitungan Koefisien Radaman pada Kondisi Sarat 22.4 cm

Periode = 1.8 det Frekwensi = 3.4907

No.	Bn	Tn	Sn	$\omega^2 \times Bn / 2g$	$\beta$	Bn/Tn	A	bn	FS	Product
1	0.0	0.224	0.0095	0.0000	0	0.000	0.0000	0.0000	1	0.0000
2	0.0785	0.224	0.0185	0.0488	1	0.350	0.0642	9.3153	4	37.2614
3	0.0	0.224	0.0095	0.0000	0	0.000	0.0000	0.0000	2	0.0000
4	0.0	0.224	0.0095	0.0000	0	0.000	0.0000	0.0000	4	0.0000
5	0.0	0.224	0.0095	0.0000	0	0.000	0.0000	0.0000	2	0.0000
6	0.0800	0.224	0.0186	0.0497	1	0.357	0.0674	10.2908	4	41.1634
7	0.0	0.224	0.0095	0.0000	0	0.000	0.0000	0.0000	2	0.0000
8	0.0	0.224	0.0095	0.0000	0	0.000	0.0000	0.0000	4	0.0000
9	0.0	0.224	0.0095	0.0000	0	0.000	0.0000	0.0000	2	0.0000
10	0.0785	0.224	0.0185	0.0488	1	0.350	0.0642	9.3153	4	37.2614
11	0.0	0.224	0.0095	0.0000	0	0.000	0.0000	0.0000	1	0.0000
Total									=	115.6861
Nz									=	3.7868
b									=	0.2452

f = 0.1 Cz = 0.3238

Periode = 1.9 det Frekwensi = 3.3069

No.	Bn	Tn	Sn	$\omega^2 \times Bn / 2g$	$\beta$	Bn/Tn	A	bn	FS	Product
1	0.0	0.224	0.0095	0.0000	0	0.000	0.0000	0.0000	1	0.0000
2	0.0785	0.224	0.0185	0.0438	1	0.350	0.0583	9.0572	4	36.2286
3	0.0	0.224	0.0095	0.0000	0	0.000	0.0000	0.0000	2	0.0000
4	0.0	0.224	0.0095	0.0000	0	0.000	0.0000	0.0000	4	0.0000
5	0.0	0.224	0.0095	0.0000	0	0.000	0.0000	0.0000	2	0.0000
6	0.0800	0.224	0.0186	0.0446	1	0.357	0.0635	10.7200	4	42.8801
7	0.0	0.224	0.0095	0.0000	0	0.000	0.0000	0.0000	2	0.0000
8	0.0	0.224	0.0095	0.0000	0	0.000	0.0000	0.0000	4	0.0000
9	0.0	0.224	0.0095	0.0000	0	0.000	0.0000	0.0000	2	0.0000
10	0.0785	0.224	0.0185	0.0438	1	0.350	0.0583	9.0572	4	36.2286
11	0.0	0.224	0.0095	0.0000	0	0.000	0.0000	0.0000	1	0.0000
Total									=	115.3374
Nz									=	3.7754
b									=	0.2042

f = 0.1 Cz = 0.2705

Periode = 2.0 det Frekwensi = 3.1416

No.	Bn	Tn	Sn	$\omega^2 \times Bn / 2g$	$\beta$	Bn/Tn	A	bn	FS	Product
1	0.0	0.224	0.0095	0.0000	0	0.000	0.0000	0.0000	1	0.0000
2	0.0785	0.224	0.0185	0.0395	1	0.350	0.0544	9.1987	4	36.7946
3	0.0	0.224	0.0095	0.0000	0	0.000	0.0000	0.0000	2	0.0000
4	0.0	0.224	0.0095	0.0000	0	0.000	0.0000	0.0000	4	0.0000
5	0.0	0.224	0.0095	0.0000	0	0.000	0.0000	0.0000	2	0.0000
6	0.0800	0.224	0.0186	0.0402	1	0.357	0.0575	10.2665	4	41.0658
7	0.0	0.224	0.0095	0.0000	0	0.000	0.0000	0.0000	2	0.0000
8	0.0	0.224	0.0095	0.0000	0	0.000	0.0000	0.0000	4	0.0000
9	0.0	0.224	0.0095	0.0000	0	0.000	0.0000	0.0000	2	0.0000
10	0.0785	0.224	0.0185	0.0395	1	0.350	0.0544	9.1987	4	36.7946
11	0.0	0.224	0.0095	0.0000	0	0.000	0.0000	0.0000	1	0.0000
Total									=	114.6551
Nz									=	3.7530
b									=	0.1780

f = 0.1 Cz = 0.2371



## Perhitungan Gaya Eksitasi Gelombang

Sarat 6.5 cm, H = 4 cm

No	Periode (dt)	Frekwensi (rad/dt)	F Kolom (N)	F Pontoon (N)	F total (N)
1	1.2	5.2360	0.0000	5.0802	5.0802
2	1.3	4.8332	0.0000	5.9077	5.9077
3	1.4	4.4880	0.0000	6.3792	6.3792
4	1.5	4.1888	0.0000	6.6378	6.6378
5	1.6	3.9270	0.0000	6.7600	6.7600
6	1.7	3.6960	0.0000	6.8027	6.8027
7	1.8	3.4907	0.0000	6.7957	6.7957
8	1.9	3.3069	0.0000	6.7620	6.7620
9	2.0	3.1416	0.0000	6.7105	6.7105

Sarat 6.5 cm, H = 2 cm

No	Periode (dt)	Frekwensi (rad/dt)	F Kolom (N)	F Pontoon (N)	F total (N)
1	1.2	5.2360	0.0000	3.0733	3.0733
2	1.3	4.8332	0.0000	4.0044	4.0044
3	1.4	4.4880	0.0000	4.6206	4.6206
4	1.5	4.1888	0.0000	5.0354	5.0354
5	1.6	3.9270	0.0000	5.3059	5.3059
6	1.7	3.6960	0.0000	5.4909	5.4909
7	1.8	3.4907	0.0000	5.6034	5.6034
8	1.9	3.3069	0.0000	5.6766	5.6766
9	2.0	3.1416	0.0000	5.7241	5.7241

Sarat 11.0 cm, H = 4 cm

No	Periode (dt)	Frekwensi (rad/dt)	F Kolom (N)	F Pontoon (N)	F total (N)
1	1.2	5.2360	0.0000	7.2955	7.2955
2	1.3	4.8332	0.0000	8.0334	8.0334
3	1.4	4.4880	0.0000	8.3747	8.3747
4	1.5	4.1888	0.0000	8.4863	8.4863
5	1.6	3.9270	0.0000	8.4632	8.4632
6	1.7	3.6960	0.0000	8.3617	8.3617
7	1.8	3.4907	0.0000	8.2298	8.2298
8	1.9	3.3069	0.0000	8.0819	8.0819
9	2.0	3.1416	0.0000	7.9220	7.9220

Sarat 11.0 cm, H = 2 cm

No	Periode (dt)	Frekwensi (rad/dt)	F Kolom (N)	F Pontoon (N)	F total (N)
1	1.2	5.2360	0.0000	4.1183	4.1183
2	1.3	4.8332	0.0000	4.9619	4.9619
3	1.4	4.4880	0.0000	5.4943	5.4943
4	1.5	4.1888	0.0000	5.8299	5.8299
5	1.6	3.9270	0.0000	6.0293	6.0293
6	1.7	3.6960	0.0000	6.1476	6.1476
7	1.8	3.4907	0.0000	6.2045	6.2045
8	1.9	3.3069	0.0000	6.2278	6.2278
9	2.0	3.1416	0.0000	6.2289	6.2289

Sarat 22.4 cm, H = 4 cm

No	Periode (dt)	Frekwensi (rad/dt)	F Kolom (N)	F Pontoon (N)	F total (N)
1	1.2	5.2360	2.0693	5.3059	7.3752
2	1.3	4.8332	2.1740	6.1232	8.2972
3	1.4	4.4880	2.1999	6.6268	8.8267
4	1.5	4.1888	2.1833	6.9253	9.1086
5	1.6	3.9270	2.1450	7.0808	9.2257
6	1.7	3.6960	2.3061	7.1480	9.4541
7	1.8	3.4907	2.0430	7.1547	9.1977
8	1.9	3.3069	1.9919	7.1272	9.1192
9	2.0	3.1416	1.9404	7.0761	9.0165

Sarat 22.4 cm, H = 2 cm

No	Periode (dt)	Frekwensi (rad/dt)	F Kolom (N)	F Pontoon (N)	F total (N)
1	1.2	5.2360	1.0283	2.9953	4.0235
2	1.3	4.8332	1.0812	3.7822	4.8633
3	1.4	4.4880	1.0949	4.3477	5.4426
4	1.5	4.1888	1.0874	4.7576	5.8450
5	1.6	3.9270	1.0689	5.0445	6.1134
6	1.7	3.6960	1.1531	5.2553	6.4083
7	1.8	3.4907	1.0189	5.3939	6.4128
8	1.9	3.3069	0.9937	5.4922	6.4859
9	2.0	3.1416	0.9682	5.5638	6.5320



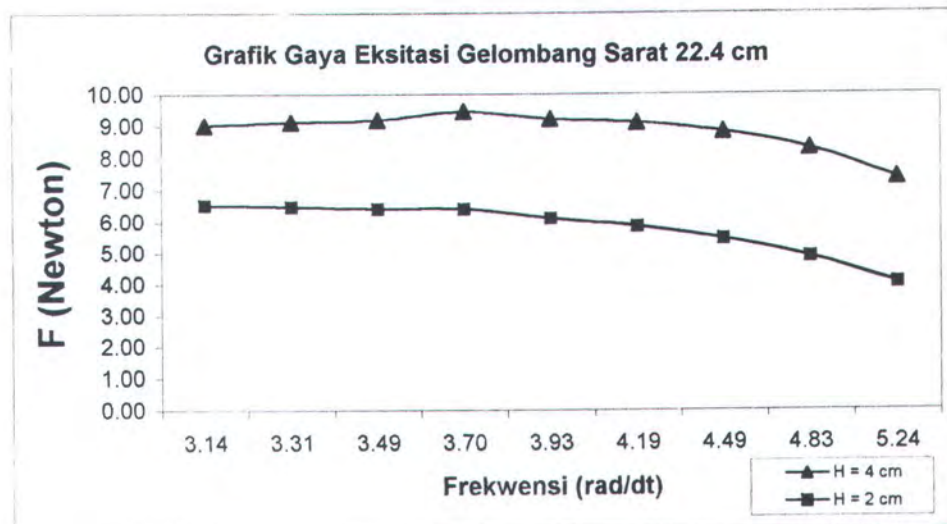
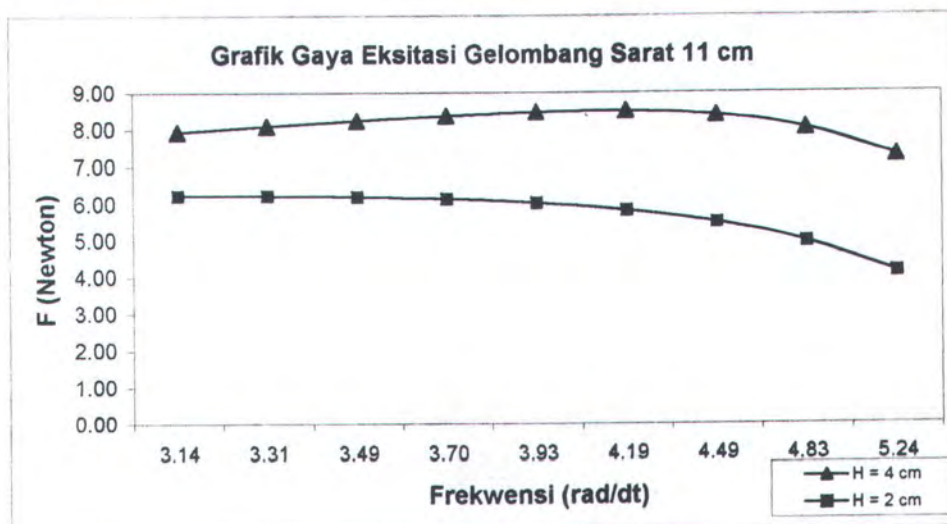
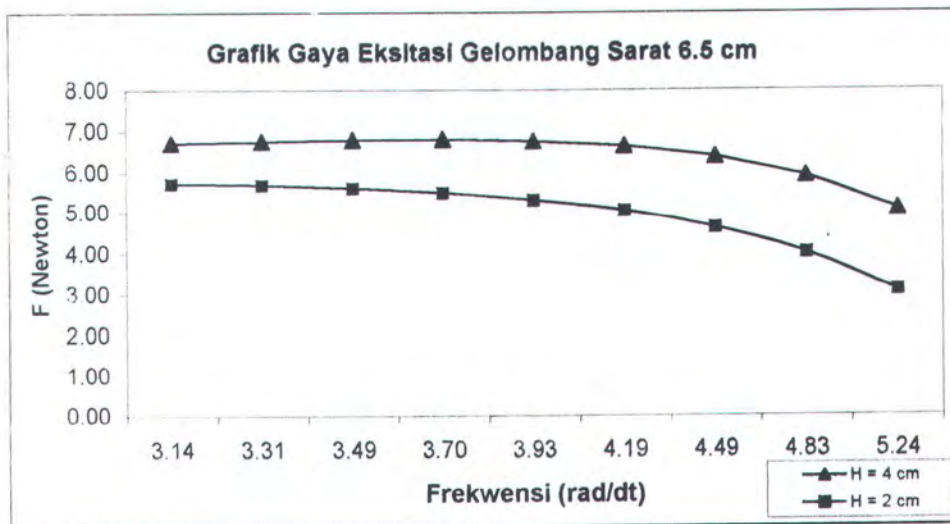



Tabel Konstanta Kalibrasi (Cc) Sarat 6.5 cm

Tanggal : 23 07 97						Keterangan
No	Nama File	H (cm)	F (Hz)	T (dt)	Foto	Cc (N/V)
1	RN230701	4	0.833	1.2	-	0.4
2	RN230702		0.769	1.3	ada	0.4
3	RN230703		0.714	1.4	-	0.4
4	RN230704		0.667	1.5	-	0.4
5	RN230705		0.625	1.6	-	0.4
6	RN230706		0.588	1.7	-	0.4
7	RN230707		0.556	1.8	-	0.4
8	RN230708		0.526	1.9	ada	0.4
9	RN230709		0.500	2.0	-	0.4
10	RN230711	2	0.833	1.2	-	0.2
11	RN230712		0.769	1.3	-	0.2
12	RN230713		0.714	1.4	ada	0.2
13	RN230714		0.667	1.5	-	0.2
14	RN230715		0.625	1.6	-	0.2
15	RN230716		0.588	1.7	-	0.2
16	RN230717		0.556	1.8	ada	0.2
17	RN230718		0.526	1.9	-	0.2
18	RN230719		0.500	2.0	-	0.2

Tabel Konstanta Kalibrasi (Cc) Sarat 22.4 cm

Tanggal : 24 07 97						Keterangan
No	Nama File	H (cm)	F (Hz)	T (dt)	Foto	Cc (N/V)
1	RN240701	4	0.833	1.2	-	0.4
2	RN240702		0.769	1.3	ada	0.4
3	RN240703		0.714	1.4	-	0.4
4	RN240704		0.667	1.5	-	0.4
5	RN240705		0.625	1.6	-	0.4
6	RN240706		0.588	1.7	-	0.4
7	RN240707		0.556	1.8	ada	0.4
8	RN240708		0.526	1.9	-	0.4
9	RN240709		0.500	2.0	-	0.4
10	RN240711	2	0.833	1.2	-	0.2
11	RN240712		0.769	1.3	-	0.2
12	RN240713		0.714	1.4	ada	0.2
13	RN240714		0.667	1.5	-	0.2
14	RN240715		0.625	1.6	-	0.2
15	RN240716		0.588	1.7	-	0.2
16	RN240717		0.556	1.8	ada	0.2
17	RN240718		0.526	1.9	-	0.2
18	RN240719		0.500	2.0	-	0.2



Tabel Konstanta Kalibrasi (Cc) Sarat 11.0 cm

Tanggal : 25 07 97						Keterangan
No	Nama File	H (cm)	F (Hz)	T (dt)	Foto	Cc (N/V)
1	RN250701	4	0.833	1.2	-	0.4
2	RN250702		0.769	1.3	-	0.4
3	RN250703		0.714	1.4	-	0.4
4	RN250704		0.667	1.5	ada	0.4
5	RN250705		0.625	1.6	-	0.4
6	RN250706		0.588	1.7	ada	0.4
7	RN250707		0.556	1.8	-	0.4
8	RN250708		0.526	1.9	-	0.4
9	RN250709		0.500	2.0	-	0.4
10	RN250711	2	0.833	1.2	ada	0.2
11	RN250712		0.769	1.3	-	0.2
12	RN250713		0.714	1.4	-	0.2
13	RN250714		0.667	1.5	-	0.2
14	RN250715		0.625	1.6	-	0.2
15	RN250716		0.588	1.7	ada	0.2
16	RN250717		0.556	1.8	-	0.2
17	RN250718		0.526	1.9	-	0.2
18	RN250719		0.500	2.0	-	0.2



### Kalibrasi Load Cell

No	Beban (gram)	Analog Volt			Rata-rata	Konstanta Kalibrasi (Cc)	
		I	II	III		Manual (Kg/V)	Otomat (N/V)
1	0	0.050	0.060	0.060	0.057	0.000	0.0
2	50	1.291	1.249	1.372	1.304	0.038	0.4
3	100	2.500	2.490	2.500	2.497	0.040	0.4
4	200	4.950	4.950	4.940	4.947	0.040	0.4
5	1000	9.300	9.080	9.380	9.253	0.108	1.0

### Angka kalibrasi Load cell 2 kg

No	Penguatan (mV/V)	Cc (N/V)
1	2.00	4.0
2	1.00	2.0
3	0.50	1.0
4	0.20	0.4
5	0.10	0.2
6	0.05	0.1



## Hasil Kalibrasi Konstanta Pegas

Beban		L1		Regangan (cm)		Cc (N/cm)	
(gr)	(N)	Pegas 1	Pegas 2	Pegas 1	Pegas 2	Pegas 1	Pegas 2
50	0.491	2.442	2.465	0.727	0.750	0.675	0.654
100	0.981	3.179	3.197	1.464	1.482	0.670	0.662
200	1.962	4.649	4.515	2.934	2.800	0.668	0.700

## Grafik Hasil Kalibrasi Konstanta Pegas

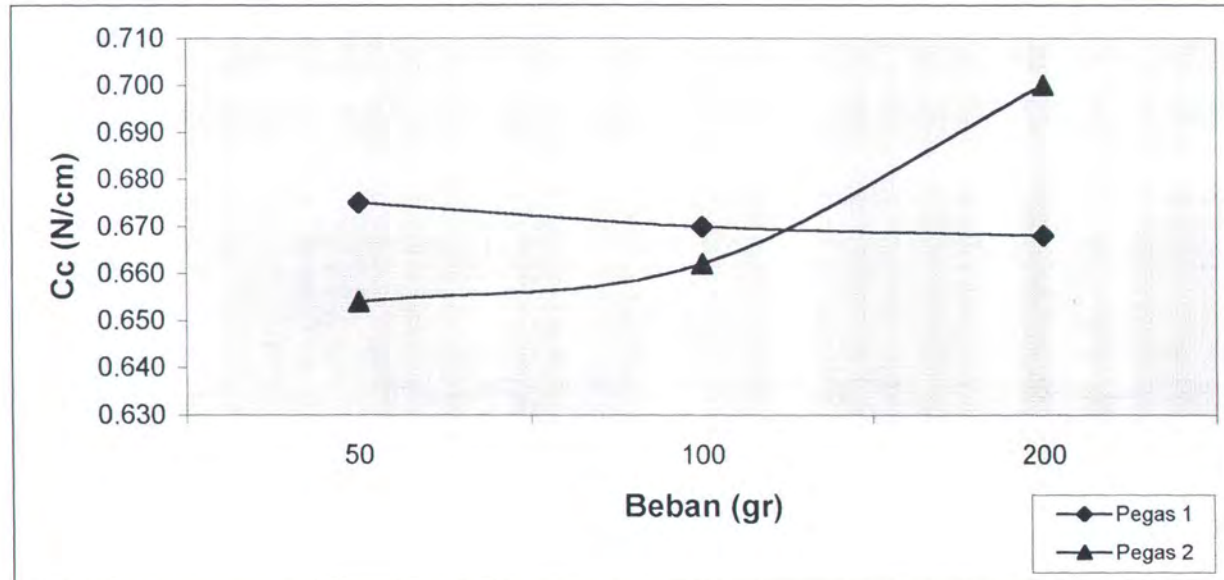



**Analisa Data Hasil Percobaan Penentuan Koefisien Redaman Surging  
Kondisi Sarat 6.5 cm**

No	Periode (dt)	$\omega$ (rad/dt)	Gaya (N)		Simpangan (m)		Kecepatan (m/dt)		b (Kg-m/dt)	
			H = 4 cm	H = 2 cm	H = 4 cm	H = 2 cm	H = 4 cm	H = 2 cm	H = 4 cm	H = 2 cm
1	1.2	5.2360	0.4153	0.0787	0.0828	0.0507	0.4338	0.2654	0.9574	0.2966
2	1.3	4.8332	1.0399	0.0719	0.0850	0.0548	0.4110	0.2647	2.5304	0.2716
3	1.4	4.4880	1.7173	0.1356	0.0933	0.0770	0.4188	0.3458	4.1009	0.3922
4	1.5	4.1888	1.4369	0.1032	0.0966	0.0746	0.4047	0.3124	3.5506	0.3304
5	1.6	3.9270	1.8024	0.1392	0.0873	0.0688	0.3427	0.2700	5.2597	0.5153
6	1.7	3.6960	2.4346	0.1138	0.0646	0.0652	0.2388	0.2411	10.1938	0.4718
7	1.8	3.4907	0.3460	0.1424	0.0692	0.0564	0.2417	0.1970	1.4318	0.7227
8	1.9	3.3069	0.0438	0.1352	0.0693	0.0536	0.2293	0.1774	0.1910	0.7621
9	2.0	3.1416	0.0298	0.1525	0.0667	0.1002	0.2097	0.3148	0.1422	0.4846

**Analisa Data Hasil Percobaan Penentuan Koefisien Redaman Surging  
Kondisi Sarat 11.0 cm**

No	Periode (dt)	$\omega$ (rad/dt)	Gaya (N)		Simpangan (m)		Kecepatan (m/dt)		b (Kg-m/dt)	
			H = 4 cm	H = 2 cm	H = 4 cm	H = 2 cm	H = 4 cm	H = 2 cm	H = 4 cm	H = 2 cm
1	1.2	5.2360	0.1299	0.0726	0.1007	0.0534	0.5270	0.2796	0.2465	0.2596
2	1.3	4.8332	0.1346	0.0770	0.0919	0.0633	0.4443	0.3061	0.3029	0.2516
3	1.4	4.4880	0.2109	0.0979	0.0864	0.0655	0.3879	0.2939	0.5436	0.3332
4	1.5	4.1888	0.3984	0.1003	0.0979	0.0597	0.4099	0.2500	0.9721	0.4010
5	1.6	3.9270	0.7425	0.0972	0.0907	0.0688	0.3561	0.2700	2.0854	0.3598
6	1.7	3.6960	1.2858	0.0941	0.0720	0.0652	0.2662	0.2411	4.8300	0.3904
7	1.8	3.4907	1.3994	0.1057	0.0649	0.0564	0.2265	0.1970	6.1797	0.5364
8	1.9	3.3069	0.9934	0.1086	0.0624	0.0536	0.2062	0.1774	4.8176	0.6123
9	2.0	3.1416	1.3203	0.1031	0.0649	0.0577	0.2040	0.1811	6.4714	0.5694



**Analisa Data Hasil Percobaan Penentuan Koefisien Redaman Surging  
Kondisi Sarat 22.4 cm**

No	Periode (dt)	$\omega$ (rad/dt)	Gaya (N)		Simpangan (m)		Kecepatan (m/dt)		b (Kg-m/dt)	
			H = 4 cm	H = 2 cm	H = 4 cm	H = 2 cm	H = 4 cm	H = 2 cm	H = 4 cm	H = 2 cm
1	1.2	5.2360	0.8146	0.1157	0.0985	0.0607	0.5156	0.3178	1.5798	0.3641
2	1.3	4.8332	0.9446	0.1301	0.1029	0.0747	0.4974	0.3611	1.8992	0.3603
3	1.4	4.4880	1.4541	0.1544	0.1048	0.0693	0.4703	0.3110	3.0917	0.4967
4	1.5	4.1888	2.0449	0.1804	0.0977	0.0746	0.4093	0.3125	4.9956	0.5771
5	1.6	3.9270	3.0918	0.2850	0.0922	0.0725	0.3619	0.2847	8.5427	1.0010
6	1.7	3.6960	3.3783	0.4526	0.0675	0.0793	0.2496	0.2931	13.5368	1.5441
7	1.8	3.4907	3.9147	0.8066	0.0766	0.0815	0.2674	0.2846	14.6372	2.8343
8	1.9	3.3069	3.9980	1.2344	0.0751	0.0827	0.2484	0.2736	16.0964	4.5116
9	2.0	3.1416	3.9980	0.0858	0.0744	0.0780	0.2338	0.2449	17.0989	0.3501



Grafik Koefisien Redaman Surging Sarat 6.5 cm

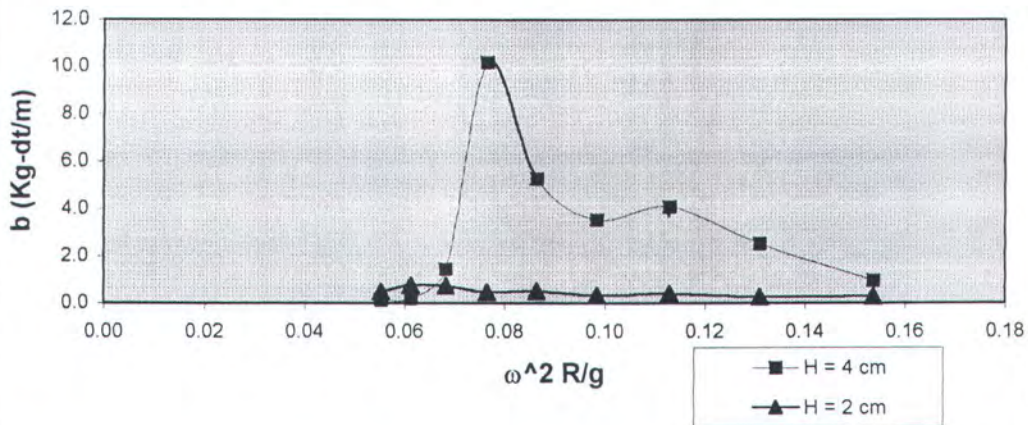

Grafik Koefisien Redaman Surging Sarat 11 cm

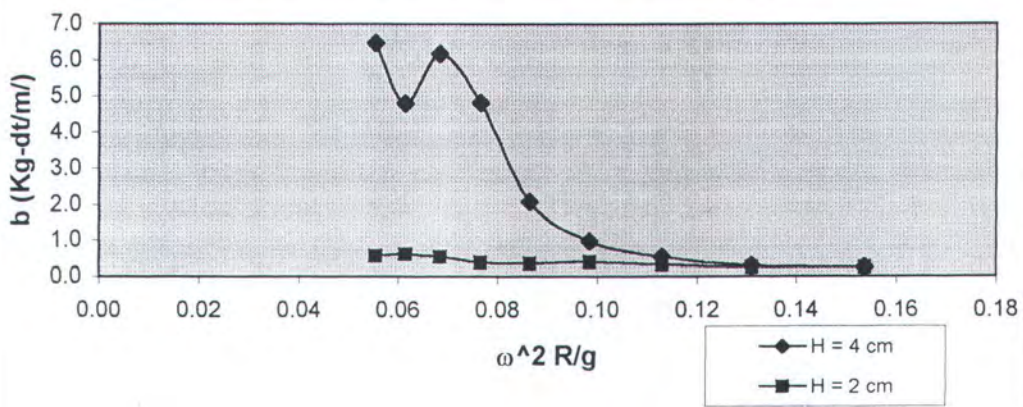

Grafik Koefisien Redaman Surging Sarat 22.4 cm

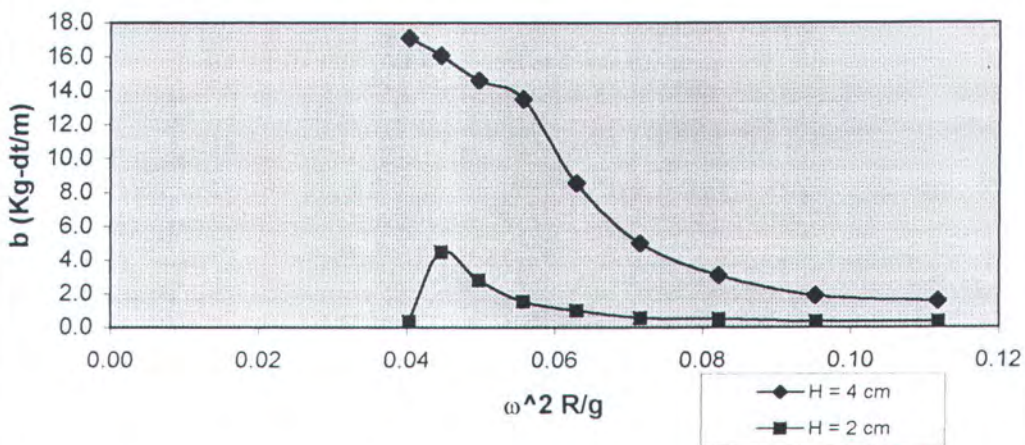



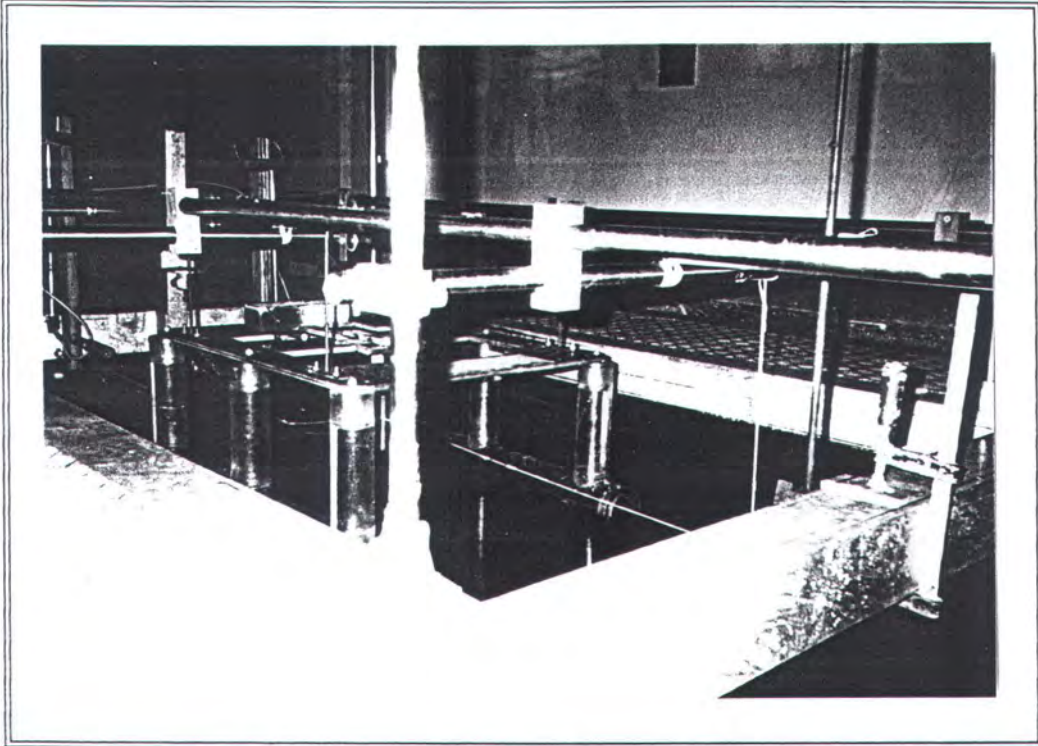

Gambar 1. Percobaan Pada Kondisi sarat 6.5 cm,  $H = 4$  cm  
Periode Gelombang 1.3 dt

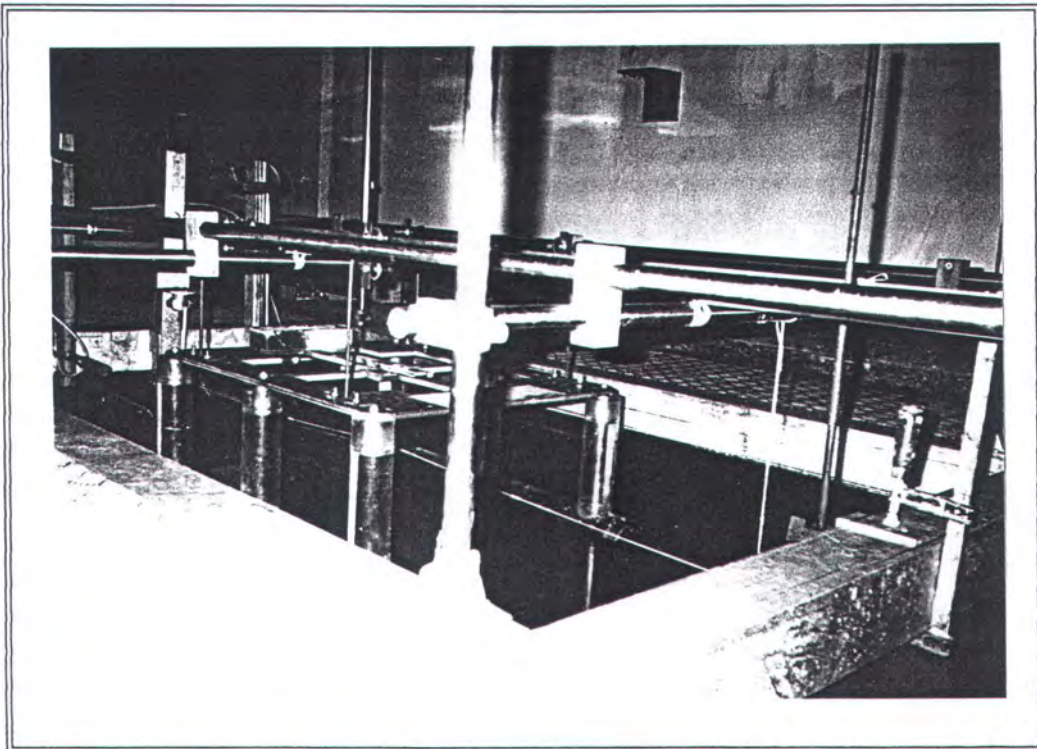

Gambar 2. Percobaan Pada Kondisi sarat 6.5 cm,  $H = 2$  cm  
Periode Gelombang 1.8 dt



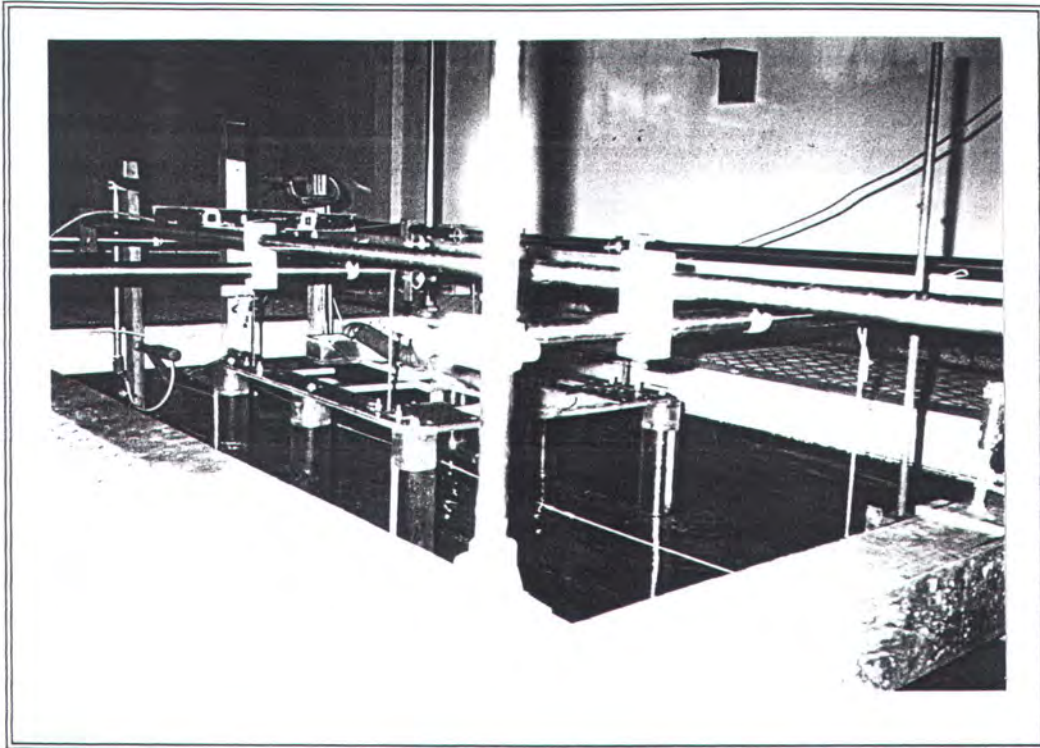

Gambar 5. Percobaan Pada Kondisi sarat 11 cm,  $H = 4$  cm  
Periode Gelombang 1.5 dt

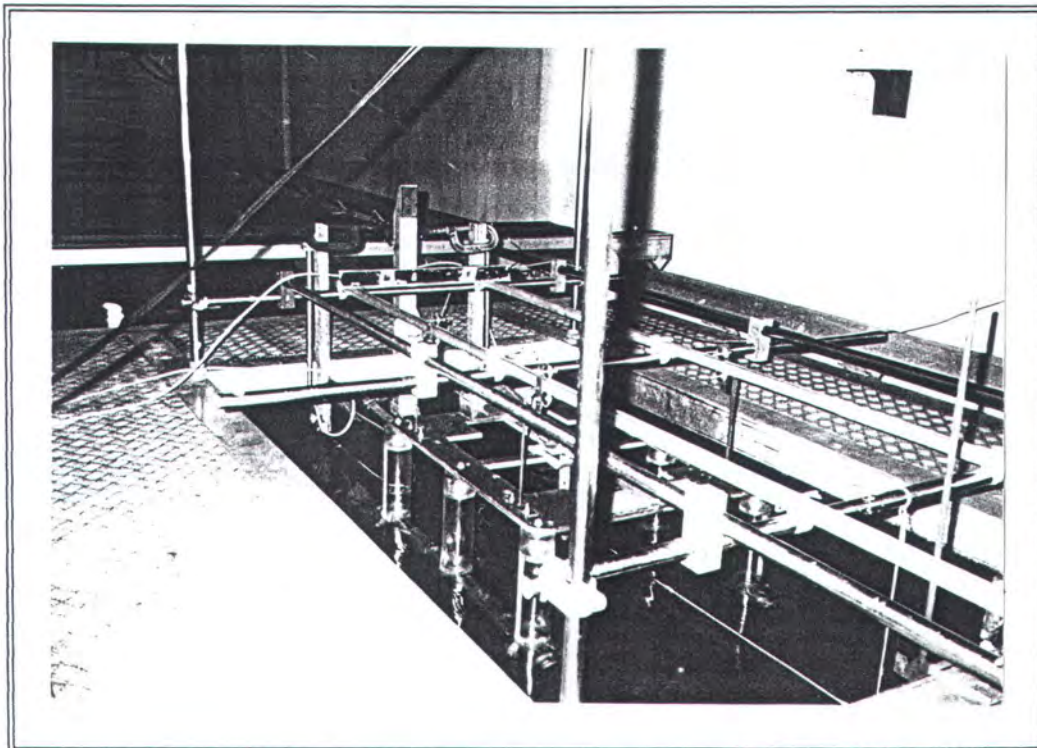

Gambar 6. Percobaan Pada Kondisi sarat 11 cm,  $H = 2$  cm  
Periode Gelombang 1.2 dt



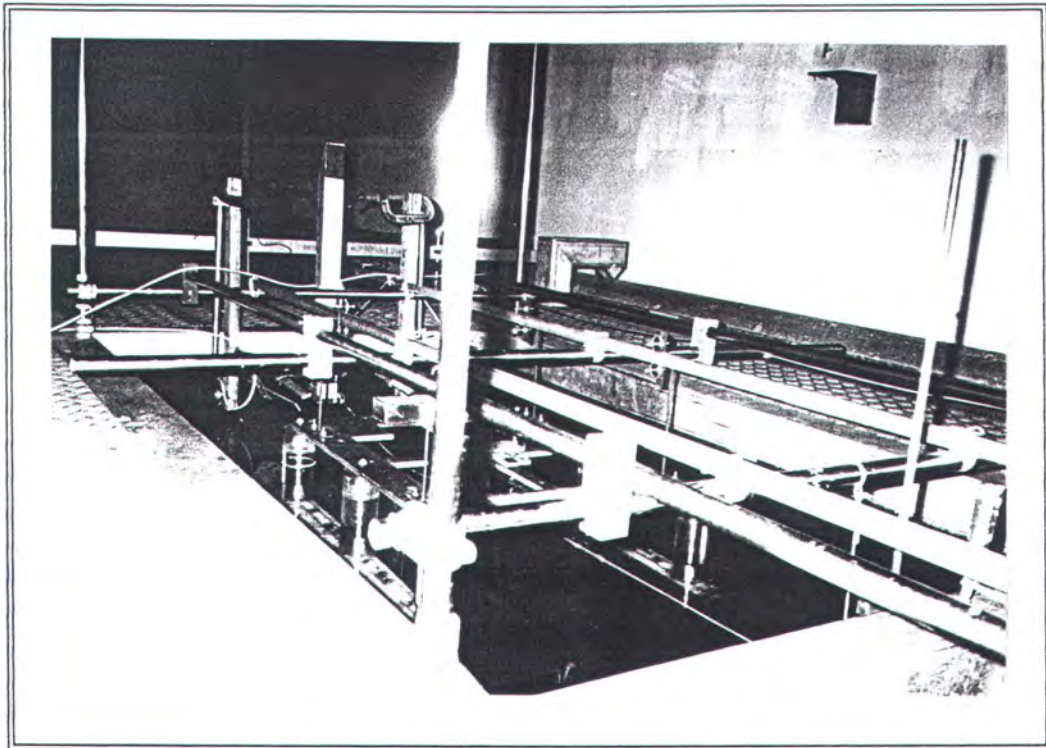

Gambar 3. Percobaan Pada Kondisi sarat 22.4 cm,  $H = 4$  cm  
Periode Gelombang 1.8 dt

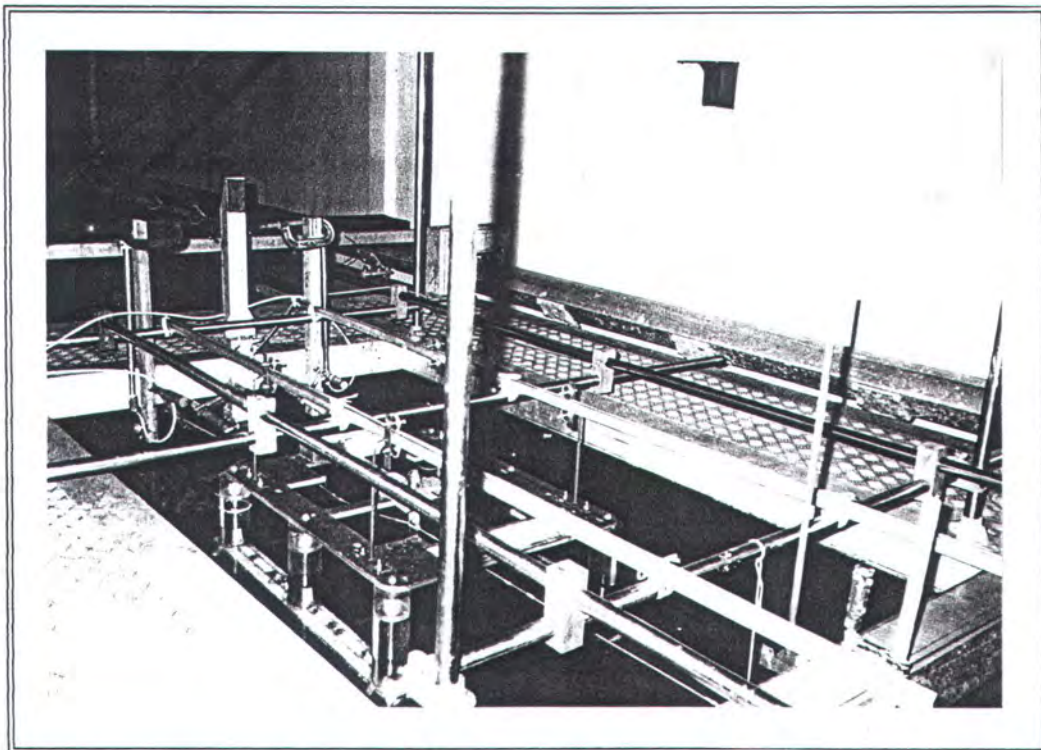

Gambar 4. Percobaan Pada Kondisi sarat 22.4 cm,  $H = 2$  cm  
Periode Gelombang 1.4 dt



