

Biogeosciences, 12, 387–398, 2015
www.biogeosciences.net/12/387/2015/
doi:10.5194/bg-12-387-2015
© Author(s) 2015. CC Attribution 3.0 License.



The effect of desiccation on the emission of volatile bromocarbons from two common temperate macroalgae

E. C. Leedham Elvidge¹, S.-M. Phang^{2,3}, W. T. Sturges¹, and G. Malin¹

¹Centre for Ocean and Atmospheric Sciences, School of Environmental Science, University of East Anglia, Norwich Research Park, Norwich, Norfolk, NR47TJ, UK

²Institute of Ocean and Earth Sciences, University of Malaya, 50603 Kuala Lumpur, Malaysia

³Institute of Biological Sciences, University of Malaya, 50603 Kuala Lumpur, Malaysia

Correspondence to: E. C. Leedham Elvidge (e.leedham@uea.ac.uk)

Received: 3 June 2014 – Published in Biogeosciences Discuss.: 11 July 2014

Revised: 29 November 2014 – Accepted: 18 December 2014 – Published: 21 January 2015

Abstract. Exposure of intertidal macroalgae during low tide has been linked to the emission of a variety of atmospherically-important trace gases into the coastal atmosphere. In recent years, several studies have investigated the role of inorganic iodine and organoiodides as antioxidants and their emission during exposure to combat oxidative stress, yet the role of organic bromine species during desiccation is less well understood. In this study the emission of dibromomethane (CH_2Br_2) and bromoform (CHBr_3) during exposure and desiccation of two common temperate macroalgae, *Fucus vesiculosus* and *Ulva intestinalis*, is reported. Determination of the impact exposure may have on algal physiological processes is difficult as intertidal species are adapted to desiccation and may undergo varying degrees of desiccation before their physiology is affected. For this reason we include comparisons between photosynthetic capacity (F_v/F_m) and halocarbon emissions during a desiccation time series. In addition, the role of rewetting with freshwater to simulate exposure to rain was also investigated. Our results show that an immediate flux of bromocarbons occurs upon exposure, followed by a decline in bromocarbon emissions. We suggest that this immediate bromocarbon pulse may be linked to volatilisation or emissions of existing bromocarbon stores from the algal surface rather than the production of bromocarbons as an antioxidant response.

1 Introduction

Seaweeds in intertidal habitats exhibit zonation patterns influenced by multiple abiotic and biotic factors. This includes the ability to tolerate desiccation during tidal emersion, which tends to determine the upper shore limit of a species. Tidal variations in exposure are natural and to survive in the intertidal region sessile organisms, including seaweeds, have evolved mechanisms to withstand the rapid fluctuations in temperature, light, salinity and nutrient availability that occur in the intertidal region. Studies have shown that seaweeds grow faster when continually submerged compared to those that are exposed during the daily tidal cycle (Williams and Dethier, 2005) strongly suggesting that emersion causes a metabolic cost to the algae. A common physiological response to stress is an increase in reactive oxygen species, ROS, and if these are produced at a rate faster than the alga can quench them this can lead to oxidative stress (Lesser, 2006). Variation in environmental conditions during exposure may also combine to enhance the impact on the algae. For example, a reduction in photosynthesis due to inorganic carbon limitation and damage to photosystem II (PSII) reduces the energy available to regenerate antioxidants (Burritt et al., 2002), thereby hindering the response to oxidative stress and reducing the ability to cope with prolonged desiccation.

Desiccation may form part of post-harvest processing for both wild and farmed seaweed species as in some cases biomass is left to dehydrate before further processing. As this process often occurs in the open potential emissions of

volatile halocarbons are likely to have atmospheric impacts. The impact of emissions during this dehydration process is an important consideration when estimating emission budgets from seaweed aquaculture (Leedham et al., 2013).

Recent studies provide evidence that a balanced stratospheric inorganic bromine (Br_y) budget requires a contribution to stratospheric Br_y from short-lived bromocarbons of mainly biogenic origin, such as dibromomethane (CH_2Br_2) and bromoform (CHBr_3). This suggests that biogenic bromine compounds may impact on tropospheric and stratospheric ozone chemistry (Montzka et al., 2010). As algae accumulate halides from seawater and emit a range of organic halogenated species they are important sources of CH_2Br_2 and CHBr_3 (e.g. Carpenter and Liss, 2000; Gschwend et al., 1984; Küpper et al., 2013; Leedham et al., 2013). It is believed that organic and inorganic halides, in their role as antioxidants, may play a role in mitigating ROS damage (Collén et al., 1994) and therefore the macroalgal adaptation to tidal exposure. In several incubation experiments, production of polyhalogenated compounds was enhanced in the light compared to the dark – evidence that halocarbon emissions could be linked to ROS production during photosynthesis (Collén et al., 1994; Keng et al., 2013; Klick, 1993; Nightingale et al., 1995; Pedersén et al., 1996). Other studies report increased bromocarbon production with the addition of H_2O_2 (Collén et al., 1994; Küpper et al., 2013) or decreased production with the addition of photosynthesis inhibitors (Goodwin et al., 1997). Methyl halides, which do not scavenge H_2O_2 , were not affected by light in the Collén et al. (1994) study.

It has been shown that variations in atmospheric abundances of polyhalomethane concentrations (including bromocarbons) over seaweed beds correspond to tidal cycles, together with bursts of iodine-containing particles at low tide (Carpenter et al., 1999; Jones et al., 2009; Mäkelä et al., 2002; Nightingale et al., 1995). This was linked to increased halocarbon production due to oxidative stress and an increased sea-air flux due to increased seawater concentrations as the water level decreased (McFiggans et al., 2004). Much of the recent work in this field has focused on emissions of molecular iodine, I_2 , (e.g. Caine et al., 2007; McFiggans et al., 2004; Palmer et al., 2005) and, until recently, the role of brominated compounds in the antioxidant/stress response to desiccation remained poorly understood. A recent study by Küpper et al. (2013) found that *Laminaria digitata* sequesters bromine from seawater (mostly as bromide) but its accumulation is far less pronounced than for iodine. It is a less suitable as an antioxidant and there was no detectable bromide flux under oxidative stress. This is perhaps expected: although *Laminaria* spp. do release volatile bromocarbons (Carpenter and Liss, 2000) they are known to be stronger emitters of iodinated compounds and to use iodide as an inorganic antioxidant (Küpper et al., 2008). However, the recent Küpper et al. (2013) study highlighted the complexity of the role bromine and bromocarbons may play in

macroalgae and that this role is not yet fully understood, in particular from species that may release larger quantities of brominated compounds. A better understanding of these processes is important for accurate quantification of coastal emission budgets, especially in intertidal regions where algae are exposed for several hours each day and, moreover, in the case of seaweed harvesting. The latter is particularly pertinent given global interest in seaweed farming as a source of chemical products and feedstocks, biofuels, food and for carbon sequestration (Schlarb-Ridley and Parker, 2013).

Here we report the results of a suite of laboratory experiments aimed at improving our understanding of CH_2Br_2 and CHBr_3 emissions during seaweed exposure and desiccation. The difference in emissions between two common temperate seaweed species, *Fucus vesiculosus* and *Ulva intestinalis*, was investigated, as was the effect of rewetting seaweeds with freshwater to mimic exposure to rainwater. This study also provides the first time series of photosynthetic capacity alongside halocarbon emissions during desiccation with the aim of increasing our understanding of the links between photosynthetic stress and bromocarbon emissions.

2 Methodology

2.1 Sample collection

F. vesiculosus (whole, individual specimens, 5–13 g dry weight) and *U. intestinalis* (groups of fronds, 3–6 g dry weight) were collected at low tide from the intertidal region of West Runton beach, Norfolk, UK (52°56' N 1°15' E). These species were selected for their contrasting morphologies: *F. vesiculosus* is a perennial species with a differentiated frond including tough, leathery blades and *U. intestinalis* is an annual with thin, tubular fronds only a couple of cells thick. As the ability to cope with desiccation is a strong determinant in zonal positioning and the extent of an individual species' range within the tidal region (Lobban et al., 1985), samples were collected from the same 2 m strip of the shore on each visit. For both species, care was taken to select intact specimens with a healthy appearance free from visible wounding (e.g. grazing damage) or epiphytes. Samples were returned to the laboratory, rinsed gently in artificial seawater (Seachem Marine Salt™ at a salinity of 32–34) and placed in a 35 L tank of aerated artificial seawater within 2 h. The tank was housed in a constant temperature room held at 13 °C (± 0.5 °C) with a light level of $\sim 180 \mu\text{mol photons m}^{-2} \text{s}^{-1}$ and a 14:10 h light:dark cycle. All samples were left to acclimatise to these conditions for 24–48 h before the first experiment began. Samples were used within one week of collection. Biological replicates were always collected on the same date. Before experiments, samples were removed from the tank with a small volume of seawater and placed in the laboratory until the seawater temperature stabilised to laboratory temperatures. In all experiments samples were weighed at the

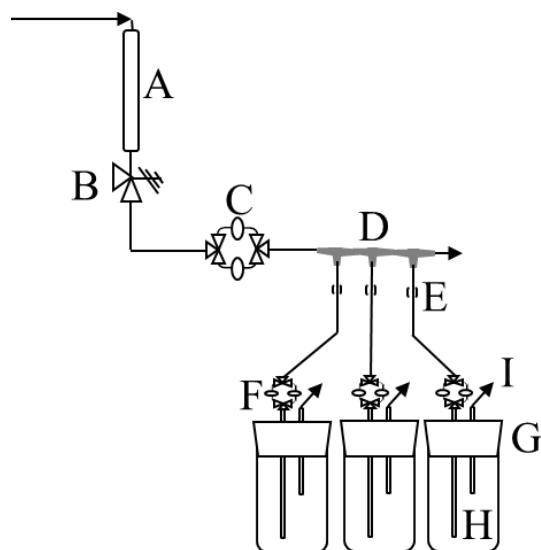

Figure 1. Desiccation system, comprising: A – hydrocarbon trap. B – pressure release valve. C – flow control system; system comprises two three-way valves and two needle valves allowing either a high or low flow to be selected. D – Luer taps to turn flow on/off to individual flasks. E – mini hose clamp to control flow through Tygon[®] tubing to each flask. F – (smaller) flow control system 2, see C. G – rubber bung and glass inlet and outlet tubes (arranged at different heights to ensure air circulation through the whole flask). H – 1 L wide-necked glass Duran[®] incubation vessel (seaweed sample placed on bottom of flask). I – 1/4 inch Ultra-torr fitting outflow, sorbent tubes or flowmeter connected here.

start and end of the experiment to determine “wet weight” (after careful blotting to remove excess water). Dry weights were also measured after drying samples for three days in a 60 °C oven followed by one day in a desiccator.

2.2 Desiccation apparatus

Halocarbon emission experiments were conducted using an in-house built system shown in Fig. 1. The air flow (commercial cylinder scrubbed using a hydrocarbon trap) to each flask was controlled individually via a series of Luer taps and flow control valves (Fig. 1c and f). These allowed for two flow rates to be established before the experiment began and then selected via a switch of a valve during the experiment. Two flow rates were used to provide a balance between the higher flow rates needed to desiccate the sample (250 mL min⁻¹, referred to henceforth as “desiccating flow”) and flow rates suitable for sorbent tube sampling (70 mL min⁻¹, referred to henceforth as “sampling flow”).

At the start of each experiment the air supply was used to flush air from the system for at least 10 min. Flow to each flask was checked every 10 min during the first hour of the experiment and at least every 30 min to 1 h thereafter using an electronic flow meter. The 70 mL min⁻¹ flow rate and 700 mL total sample volume were within the quoted “safe

sampling volumes” and recommended flow rate ranges given by Markes International (2012, 2008) for their sorbent sampling tubes. A thermometer attached to the frame provided daily temperature readings and during the ~ 5 month spread of experiments temperature varied between 19–22 °C. One flask was always used as a control. As tube sorption efficiency may be affected by air moisture levels (Markes International, 2012) a small volume of artificial seawater was added to the control flask and this flask was observed to still contain signs of moisture at the end of each experiment.

2.3 Sorbent tube sampling and analysis

To quantify halocarbon emissions at high resolution, thermal desorption tubes (Markes, UK) were used. These contained three sorbents (in order of increasing sorbent strength): Tenax TA, Carbograph 1TD and Carboxen 1000. As previous work (Hughes et al., 2012, 2009) established that trapping efficiency was improved with the use of cold tubes, tubes were stored at –18 °C before use and were wrapped in reusable frozen gel packs (as used for sports injuries) to keep them cold for the duration of sampling. The temperature within the gel packs was usually 0–2 °C with an occasional maximum of 5 °C. To prevent post-sampling migration of bromocarbons between sorbents the tubes were returned to the freezer until analysis. The majority of samples were analysed within 7 days of collection and all were analysed within 2 weeks. Sample stability of up to 16 months was reported by Hughes et al. (2009).

Air samples were preconcentrated using an automated Markes ULTRA[™] multi-tube autosampler and UNITY[™] thermal desorption/sample preconcentration system following standard Markes protocols. Briefly, the ULTRA[™] desorbed analytes from each tube at 300 °C for 5 min and transferred them in a flow of high purity helium along a short, insulated transfer line to the UNITY[™], where they were concentrated on a trap (commercially packed by Markes with glass wool, Tenax TA, Carbograph 1TD and Carboxen 1000) held at –10 °C. The cold trap was then heated to 300 °C for 15 min to desorb the analytes into a flow of helium and transfer them along a 200 °C heated transfer line to an Agilent 6890 gas chromatograph (GC) fitted with a 60 m DB-VRX capillary column (J&W Ltd.; 0.32 mm diameter, film thickness 1.8 µm). An Agilent 5973 mass spectrometer (MS) in electron impact single ion mode provided quantification, and identification of each halocarbon was via retention time comparison with a known standard using at least two known mass fragments. ULTRA[™] systems can hold up to 100 tubes, but as the tubes are held at ambient temperature we loaded a maximum of 10 tubes at any one time to minimise losses or migration of halocarbons within the tubes. Each batch of 10 tubes included one blank, 2–3 standards and 6–7 samples. Blank tubes were used to verify the effectiveness of tube cleaning and storage and to monitor changes in background

bromocarbon levels in the system over time. No significant contamination was observed in blank tubes during this study.

Sample concentrations were calculated relative to a UEA calibration flask comprised of background air calibrated to the NOAA scale. A discussion of UEA-NOAA intercomparisons can be seen in Leedham-Elvidge et al. (2014). Due to the high range of bromocarbon concentrations observed during our experiments we also performed tests to ensure the detector was linear in excess of the range of detector responses we observed. To do this we purged aqueous standards of concentrations between 0–950 pmol L⁻¹ onto tubes (see Hughes et al., 2009), a range that gave a detector response that exceeded the maximum response we saw in our experiments, and observed a linear detector response ($R^2 = 0.98$, $p = < 0.01$). Sorbent tubes charged with labelled surrogate analytes, deuterated methyl iodide (CD₃I) and ¹³C-labelled dibromoethane (¹³C₂H₄Br₂), purged from aqueous samples (Leedham et al., 2013), were also used to monitor and account for any drift in system sensitivity. The standards were trapped onto chilled sorbent tubes exactly as for sample collection to provide a calibration of the entire analytical system and standards were run roughly every three tubes for a point concentration calibration. The overall error on the calculated concentrations was 6.66 % for CH₂Br₂ and 7.43 % for CHBr₃.

2.4 Experiments

Table 1 provides details of individual experiments conducted as part of this work. Codes given in the first column will be used throughout the text for brevity. Experiments included:

1. Mass loss during desiccation. Seaweed samples were placed in the desiccation system (Fig. 1) for varying periods of time. Specimens were removed at regular intervals to be weighed. For this reason halocarbon emissions were not measured concurrently. Mass loss experiments were designed to replicate the pattern of desiccating and sampling flow rates of both short (FS/US) and long (FL/UL) halocarbon experiments with a sampling rate of ~3 samples an hour up for the first 3 h of the experiment and ~1 sample an hour for the remainder.
2. Photosynthesis experiments. A Walz PHYTO-PAM (Pulse-Amplitude-Modulation fluorometer) with an Emitter-Detector-Fiberoptics Unit (EDF) attachment (commonly used for periphyton/microphytobenthos measurements) was used to provide a measure of how stress affected PSII by comparing the dark-adapted fluorescence state with a light saturated state (achieved by application of a saturating light pulse to the dark-adapted sample so that its reaction centres close). The resulting value, the maximum potential quantum efficiency (F_v/F_m), is lower in stressed samples where more reaction centres are already shut prior to light saturation and so there is less difference between the two

states. Due to the need to dark adapt samples before fluorescence measurements were taken it was impractical to desiccate samples within the incubation chambers. Instead, samples were dried under the same light and temperature conditions but in shallow glass petri dishes (coated in black tape to block light from the sides) on a lab bench. A household fan was used to provide movement of air to aid desiccation and the temperature remained within the range of laboratory temperatures given above. The first F_v/F_m measurement for each sample was made when the specimen was submerged in a small volume of water from the seaweed storage tank. This water was then removed and the alga weighed. Periods of desiccation were interspersed with periods of 15 min dark adaptation followed immediately by F_v/F_m measurements. During UP2, light and temperature fluctuations in the lab were recorded (78 to 110 $\mu\text{mol photons m}^{-2} \text{s}^{-1}$ and 22.5–23.5 °C respectively). Samples were weighed periodically to provide an indication of mass loss.

3. Halocarbon emission during desiccation. Seaweed samples were placed in the desiccation system (Fig. 1) for varying periods of time. In UR1 and UR2 *U. intestinalis* specimens were rewetted with ~50 mL of deionised water after a period of desiccation varying from ~3–8 h.

3 Results

3.1 Mass/water loss during desiccation

Results of the mass loss experiments are depicted in Fig. 2. We assume mass loss is equivalent to water loss (as in Bravo-Linares et al., 2010) and take changes in mass as a measure of the rate of desiccation. Two mass loss experiments (FM1 and FM2, $n = 5$) were performed on *F. vesiculosus* and one on *U. intestinalis* ($n = 3$). Of the 5 *F. vesiculosus* replicates 3 showed a relatively constant loss of water, with rates of 0.22 (SD = 0.06), 0.18 (SD = 0.03) and 0.18 (SD = 0.06) % min⁻¹ respectively. Corresponding linear fits (Fig. 2) for these 3 replicates had R^2 values of 0.995, 0.994 and 0.981 respectively. The final two replicates did not show a linear decay, the loss rate slowed during the latter half of the experiment. This change in loss rate occurred around the time that the experimental procedure switched from ~3 samples an hour to ~1 sample an hour (see Sect. 2.4 – this was to replicate “short” (e.g. FS1) and “long” (e.g. FL1) halocarbon emission experiments). As the change occurred around the time of a switch in experimental procedure we did not fit a decay curve to these replicates and have added a marker to Fig. 2 to show where the experimental change occurred. *U. intestinalis* lost water faster and to a larger extent than *F. vesiculosus*: both the total percentage water loss and the

Table 1. A summary of the desiccation experiments conducted as part of this study.

Code ^a	Description	Experiment date ^b	# Replicates	# Control samples	Specimen mass/g ^c	Description
Mass loss during desiccation experiments						
FM1	<i>F. vesiculosus</i> mass loss	21st Mar	3	n/a	6.0, 10.7 & 9.7	As for halocarbon production experiments but specimens weighed 3 times an hour.
FM2		23rd Mar	2	n/a	9.7 & 12.1	
UM	<i>U. intestinalis</i> mass loss	22nd Mar	3	n/a	4.3, 4.8, 3.8	
<i>F_v/F_m</i> experiments						
FP	<i>F. vesiculosus</i> photosynthetic performance during desiccation	19th Jun	3	n/a	13.8, 10.5 & 12.1	Specimens dried on laboratory bench in petri dishes. <i>F_v/F_m</i> samples taken twice an hour.
UP1	<i>U. intestinalis</i> photosynthetic performance during desiccation	19th Jun	3	n/a	4.6, 2.4 & 3.0	
UP2		21st Jun	3	n/a	3.0, 3.6 & 3.2	
Halocarbon production						
FS1	<i>F. vesiculosus</i> short desiccation	31st Jan	1	1	7.9	Samples taken every 10 min for 2 h; submerged for first 3 samples.
FS2		3rd Feb	1	1	13.0	
FS3		14th Feb	1	1	6.6	
FL1	<i>F. vesiculosus</i> long desiccation	12th Mar	2	1	5.2 & 7.9	As FS2. Samples taken every 20 min for 8 h.
FL2		20th Mar	2	1	6.6 & 7.2	Samples taken every 20 min for 5 h
US1	<i>U. intestinalis</i> short desiccation	23rd Feb	1	1	6.0	Samples taken every 10 min for 2 h; submerged for first 2 samples.
US2		2nd Mar	1	1	4.0	
UL1	<i>U. intestinalis</i> long desiccation	14th Mar	2	1	3.2 & 3.0	Samples taken every 20 min for 8 h.
UR1	<i>U. intestinalis</i> desiccation followed by rewetting in freshwater	12th Apr	2	1	4.4, 4.4	Samples taken hourly for 3.5 h > specimens rewetted > samples taken every 10 min for 2.5 h.
UR2		26th Apr	2	1	3.4, 5.0	Samples taken every 20 min for 8 h > specimens rewetted > samples taken every 10 min for 2 h.

^a Code describes experiment as follows: first letter = species ($F = F. vesiculosus$, $U = U. intestinalis$), second letter = experiment type ($S =$ short (3 h or less) desiccation, $L =$ long desiccation, $R =$ rewetting, $M =$ mass loss and $P = F_v/F_m$ experiment), number = individual experiments conducted at different times. Lower-case letters used in the main body of the text (e.g. FL1a, FL1b) refer to replicates within these individual experiments. ^b All experiments conducted in 2012. All samples used within 1 week of collection. ^c Mass is fresh weight at start of experiment.

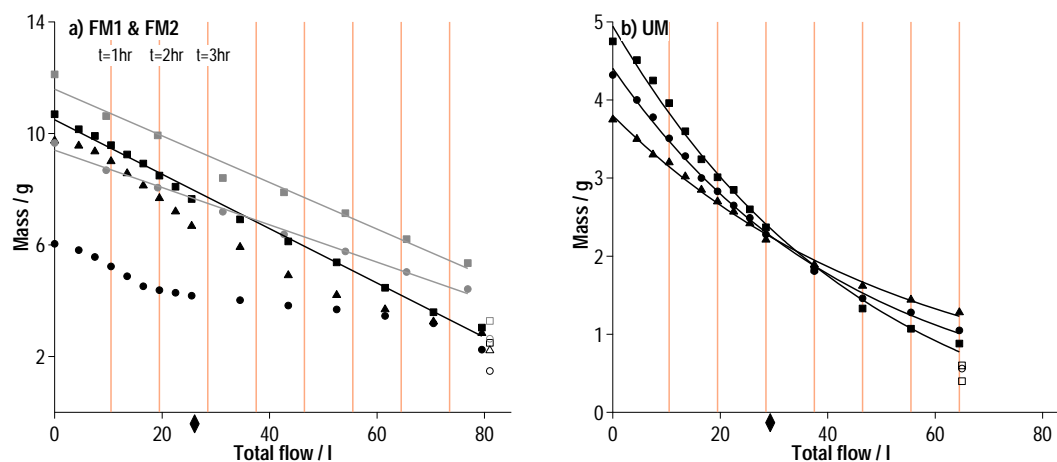

Figure 2. Mass (water) loss during desiccation of (a) *F. vesiculosus* (FM1 in black and FM2 in grey) and (b) *U. intestinalis* (UM). For details of replicates see Table 1, individual replicates are denoted by different marker shapes. Open shapes show dry mass of each sample (see Sect. 2.1). Vertical lines = 1 h intervals from start (0 h) of desiccation. ♦ = time experimental procedure switched from sampling 3 times an hour to sampling once per hour (see Sect. 2.4). Patterns in mass loss are discussed further in Sect. 3.1; loss in *U. intestinalis* (b) has been represented with an exponential decay curve. Loss in *F. vesiculosus* was more varied, however some replicates showed a linear loss of mass (see Sect. 3.1 for more details).

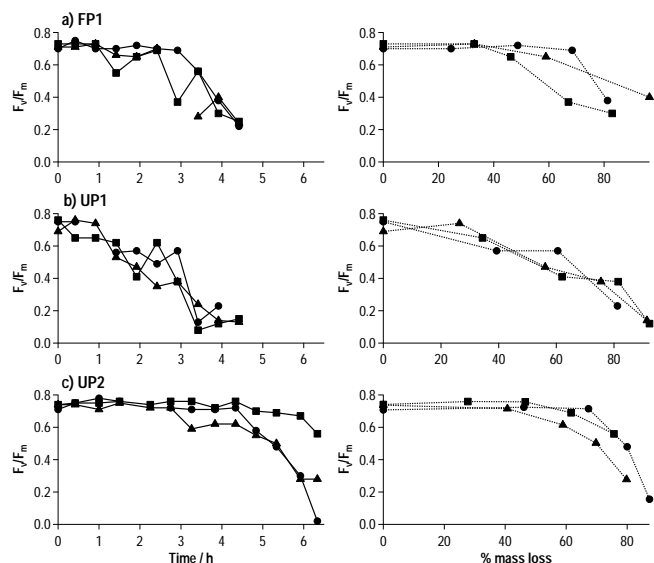

Figure 3. F_v/F_m changes relative to time (left column) and % mass loss (right column) during desiccation of (a) *F. vesiculosus* and (b, c) *U. intestinalis*. Sample mass was not measured at every time point, see Sect. 3.2 for further details. Symbols represent the three biological replicates used in each experiment, see Table 1 for further details.

percentage loss rate per hour were greater for *U. intestinalis* than *F. vesiculosus*. At the end of the experiment *U. intestinalis* weighed between 31–68 % more than its dry mass compared to 66–82 % for *F. vesiculosus*. As a consequence, water loss in *U. intestinalis* slowed toward the end of the experiment as the amount of water available within the algae decreases substantially and the rate of water loss was not as linear as for *F. vesiculosus* (exponential fits have been applied to the *U. intestinalis* mass loss plots in Fig. 2).

3.2 F_v/F_m changes during desiccation

Changes in F_v/F_m during desiccation of both species can be seen in Fig. 3. As F_v/F_m experiments were conducted under different conditions to mass loss and halocarbon experiments (Sect. 2.4) sample mass was also measured at several time points during the F_v/F_m experiments and F_v/F_m changes relative to mass (water) loss are also shown in Fig. 3. Initial measurements of all replicates in our experiments, made when the specimens were submerged in a small volume of seawater, were ~ 0.7 . As environmental factors and history can play a role in determining F_v/F_m (Walz, 1998) care must be taken when comparing F_v/F_m results between studies. Our starting F_v/F_m values, nevertheless, compare well with previous studies which report F_v/F_m values for healthy *F. vesiculosus* and *U. intestinalis* samples of ~ 0.7 – 0.8 (Lewis et al., 2001; Magnusson, 1997; Pearson et al., 2000).

In FP1 and UP2 F_v/F_m remained stable for some time before beginning to decline in hours 3–5 (Fig. 3a and c). In UP1

(Fig. 3b) F_v/F_m began to decrease earlier but still remained fairly constant within the first hour of the experiment. The difference between UP1 and UP2 may be attributable to different light levels on the sampling day, inherent biological variability or different environmental histories of the samples collected. Previous studies investigating oxidative bursts show the initial burst to be the largest (Küpper et al., 2001), suggesting that samples with different stress histories may respond differently to laboratory stresses. Mass loss measured during the F_v/F_m experiments showed substantial water loss within this first hour, supporting the results from the FM and UM mass loss experiments. These results show that, despite significant water losses within the first hour of desiccation (19–25 % for FP1 and 15–31 % for UP1, mass of UP2 was not re-measured until 2 h into the experiment), photosynthetic capacity was unaffected. As shown by the F_v/F_m vs. mass loss plots (Fig. 3) mass losses of around 40–60 % were observed before F_v/F_m values in FP1 and UP2 began to decline. This could indicate that a certain threshold, with respect to water loss or physiological stress, must be reached before F_v/F_m is affected. However, we did not see this response during UP2 where the F_v/F_m values declined steadily throughout the experiment. Due to this variation, and as we did not measure specimen mass at every F_v/F_m measurement point, further research into threshold stress levels during the desiccation of algae are warranted. The delay in the decline in the F_v/F_m response suggests that the initial burst in halocarbon emissions (Sect. 3.3) are not related to the photosynthetic health of the plants, this will be discussed further in Sect. 4. The overall pattern of decrease observed during these experiments fits with previous studies that report decreasing photosynthesis during desiccation (e.g. Peña et al., 1999).

3.3 Bromocarbon emissions during desiccation

The bromocarbon concentrations observed in the desiccation flasks during the FS, FL, US and UL experiments, and production rates calculated from these concentrations, are shown in Figs. 4 (FS and FL) and 5 (US and UL). Refer to Table 1 for descriptions of individual experiments and replicates. Experiments are displayed relative to total flow volume (not time) to standardise between experiments with different sampling procedures and therefore exposures to different volumes of air. All specimens demonstrated bromocarbon emissions whilst control flasks maintained low concentrations, 0–2 ppt for CH_2Br_2 and 0–3.7 ppt for CHBr_3 , for the duration of the incubations. Variation in bromocarbon production rate varied considerably between some algal specimens, even those collected from the same location at the same time. For example the maximum production rate (rates were calculated for each sampling period) observed for replicate FL1a was around three times higher than that seen in replicate FL1b ($\sim 0.01 \text{ pmol g DW}^{-1} \text{ min}^{-1}$ compared to $\sim 0.03 \text{ pmol g DW}^{-1} \text{ min}^{-1}$, Fig. 4). Variation

between individual algal specimens is not unexpected as it has been reported in previous desiccation studies (Ball et al., 2010) and was discussed in detail in Leedham et al. (2013).

Five experiments (FS1 to 3 and US1 and 2) started with the algal specimen in the incubation flask still submerged in seawater so that the immediate effect of exposure could be observed. In FS1 to 3 (Fig. 4) concentrations increased after exposure and began to plateau or decrease within the 2–3 h duration of these experiments. The extremely low concentrations when the algae were submerged are likely due to the fact that a constant flow of gas passed through the flask headspace and the flux of bromocarbons from the seawater to the air was not sufficient to cause an increase in bromocarbons during the residence time of the air. Upon exposure, bromocarbons on or close to the surface of the algae could flux directly to the headspace, leading to an increase in observed concentrations as well as the immediate peak seen in experiments where samples were exposed from the start of the experiment (FL1 and FL2, Fig. 4). In FL1 and FL2 bromocarbon concentrations began to decline after the first sample (within the first hour). In FL2 a second peak was observed after about 4 h of desiccation, although only in one sample. In both FL experiments the majority of samples concentrations had declined to, or were close to, control levels within 5 h of exposure (Fig. 4). Short (FS1 to FS3) and long (FL1 and FL2) experiments differed in that FL1 and FL2 exposed the algal specimens to longer periods of high “desiccating” flow rates as samples were taken once per hour (Table 1). This difference may play a role in the different bromocarbon responses seen between FS and FL experiments. No differences in the range of concentrations were observed between FS and FL experiments (or US and UL experiments). For example, the range of observed CH_2Br_2 concentrations was around 0–100 ppt in all *F. vesiculosus* experiments (FS1 to FS3 and FL1 and FL2, Fig. 4). US1 and US2 (Fig. 5) showed similar patterns to *F. vesiculosus* experiments, with a peak in bromocarbon emissions within the first couple of hours. UL1 (Fig. 5) showed sustained halocarbon concentrations that were not seen in the FL experiments with concentrations of both CH_2Br_2 and CHBr_3 remaining similar to starting concentrations up to 5–7 h after the experiment began. *U. intestinalis* produced more bromocarbons than *F. vesiculosus* with production rates of up to $0.3 \text{ pmol g DW}^{-1} \text{ min}^{-1}$ for CH_2Br_2 and up to $3 \text{ pmol g DW}^{-1} \text{ min}^{-1}$ for CHBr_3 . In comparison, *F. vesiculosus* production rates reached maximum values of $0.2 \text{ pmol g DW}^{-1} \text{ min}^{-1}$ and $0.9 \text{ pmol g DW}^{-1} \text{ min}^{-1}$ for CH_2Br_2 and CHBr_3 respectively.

All experiments showed similarities between CH_2Br_2 and CHBr_3 emission patterns. This is not unexpected given that many field and laboratory experiments have demonstrated highly correlated concentrations of CH_2Br_2 and CHBr_3 in seaweed emissions or air influenced by said emissions (e.g. Carpenter and Liss, 2000; Leedham et al., 2013). This strong correlation is considered to be due to these bromocarbons

sharing the same production mechanism (Manley, 2002). The emission ratio, $\text{CH}_2\text{Br}_2 : \text{CHBr}_3$ calculated from a linear regression plot (not shown) was calculated for each experiment with $n > 5$ data points (all except FS1). A strong correlation ($R^2 = 0.57\text{--}0.95$) between these two gases was seen for all experiments except FS2. For these experiments (FS3, FL1 and FL2) the $\text{CH}_2\text{Br}_2 : \text{CHBr}_3$ ratio fell between 0.12–0.40. A range that falls within the existing range of values for this ratio, the lower value being similar to a ratio of 0.14 observed by Carpenter and Liss (2000) in coastal air samples and the upper value being similar to a ratio of 0.46 observed in measurements of seawater samples from laboratory cultures by Leedham et al. (2013).

Our results show that, for many of the replicates, the majority of the halocarbon “response” (increasing concentrations or peaks in bromocarbon emissions) began immediately or within the first hour of exposure. This does not correlate with the F_v/F_m response, outlined in the previous section and will be discussed further in Sect. 4.

3.4 Rewetting experiments

To investigate the impact of freshwater (e.g. rainfall) rewetting on bromocarbon emissions two experiments (UR1–2) were conducted on *U. intestinalis*. The addition of water will impede the halocarbon flux as halocarbons partition first to the aqueous phase and then flux to the headspace. We attempted to minimise this factor by adding enough water to fully rewet each specimen without creating a large depth of water above the algae. The results for CH_2Br_2 and CHBr_3 can be seen in Fig. 6. The length of desiccation prior to rewetting varied from 3.5 h for UR1 and ~ 8 h for UR2, and this possibly contributed to the differences in the magnitude of halocarbon response observed upon rewetting. In UR2 a slight increase in both CH_2Br_2 and CHBr_3 was observed, however, this is of no greater magnitude than other fluctuations observed during the desiccation process (Fig. 5). UR1, however, demonstrated a larger increase in both CH_2Br_2 and CHBr_3 emissions after freshwater rewetting. The increase in emissions was observed over several samples and rose to over half the maximum emission near the start of the experiment, showing a response above the variation seen in the previous *U. intestinalis* experiments (US1 and 2, UL1, Fig. 5). At the end of the UR1 sampling period concentrations of CH_2Br_2 and CHBr_3 in the flasks appeared to still be increasing. However, due to the natural variability in algal emissions, as demonstrated in Figs. 4 and 5, further experiments are needed to determine a conclusive response to freshwater rewetting. Emission patterns pre-rewetting in UR1 and UR2 (Fig. 6) act as replicates for UL1 (Fig. 5) as they were conducted in the same manner. They also show emissions taking longer to decrease than seen in the *F. vesiculosus* experiments.

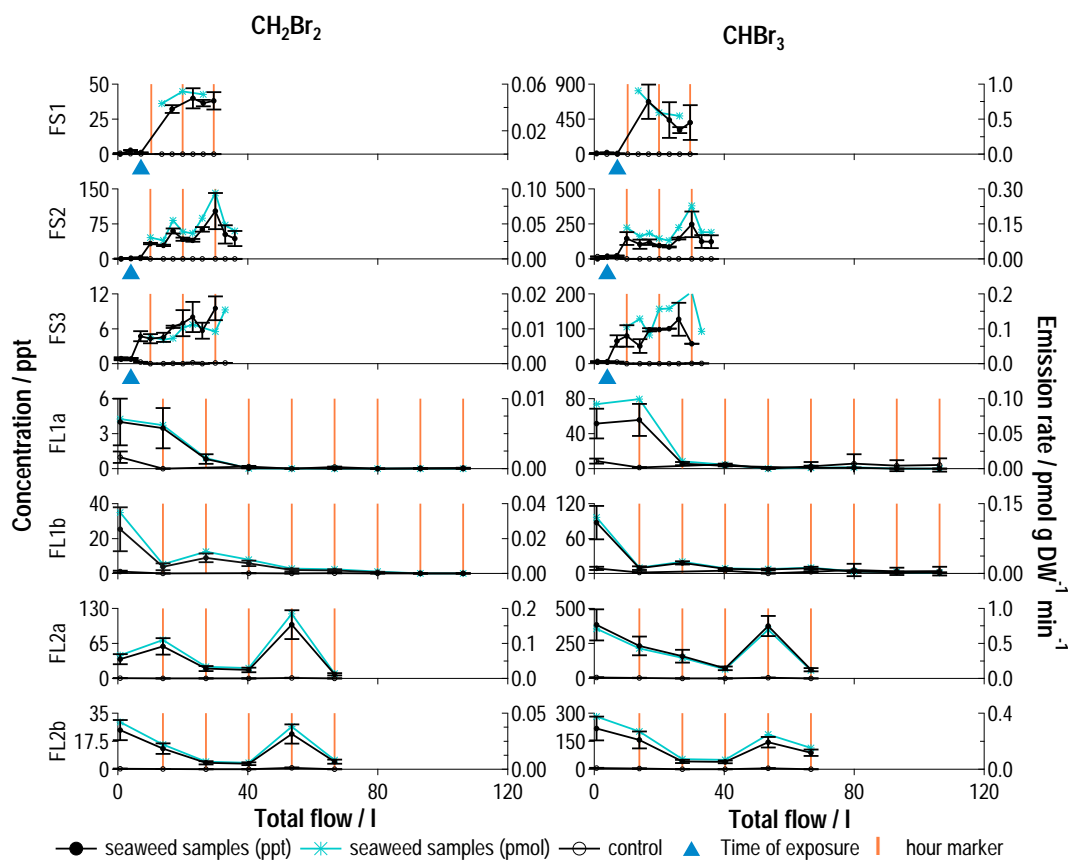

Figure 4. Bromocarbon concentrations (ppt, left axis) and production rates ($\text{pmol g DW}^{-1} \text{min}^{-1}$, right axis) observed in flasks during desiccation of *F. vesiculosus*. Changes are shown relative to total flow (L) for easier comparison between experiments that used different flow regimes (Sect. 2.2/Table 1). Experiments conducted at different times are denoted by individual numbers (e.g. FS1, FS2). Within these experiments replicates in different flasks (Fig. 1) are denoted by individual letters (FL1a, FL1b), see Table 1 for further details. Error bars are taken from the daily variations in calibration standards. Vertical lines = 1 h intervals from start (0 h) of desiccation. For experiments that began with submerged seaweed samples the exposure point is marked with a triangle.

4 Discussion

Previously published bromocarbon desiccation studies focused on natural halocarbon production mechanisms in coastal waters and did not concentrate on the timescale of emissions. Two studies (Bravo-Linares et al., 2010; Nightingale et al., 1995) desiccated algae for several hours but measurements were made to monitor the resubmergence of seaweeds after exposure and not during exposure itself. A pulse of halocarbon emissions into seawater upon reimmersion was reported by Nightingale et al., whereas Bravo-Linares et al. reported a general increase in iodinated compounds but a general decrease in brominated compounds compared to samples that had not undergone desiccation. As physiological stress or damage can be caused by reimmersion as well as exposure (because rehydration alters the cell membrane leading to a flux of ROS upon reimmersion; Collén and Davison, 1999), this response could be linked to stresses associated with reimmersion as well as desiccation.

Both *F. vesiculosus* and *U. intestinalis* showed relatively linear patterns of water loss, as seen in previous studies (Bravo-Linares et al., 2010; Ji and Tanaka, 2002). *U. intestinalis* dried faster, losing $\sim 50\%$ of its water after 4 h compared to $\sim 35\%$ for *F. vesiculosus*, in line with Lüning (1990) who reported 20–30% water loss for fucoid species after 4 h. This may be due to its thinner thallus form allowing for faster water loss. In contrast to our results, Bravo-Linares et al. (2010) found that *U. intestinalis* was better than *F. vesiculosus* at retaining water due to its structure, trapping water between its fronds to prevent it drying out. In our study, *U. intestinalis* was spread out to form a thin mat, potentially negating the benefits conveyed by the multiple fronds trapping water. The *U. intestinalis* mat could increase the surface area of the alga exposed to desiccation (Davison and Pearson, 1996), making the *U. intestinalis* in our study more like flatter *Ulva* species, such as *U. lactuca* and *U. pertusa*, which had higher rates of water loss in previous studies due to their larger surface area (Bravo-Linares et al., 2010; Ji and Tanaka,

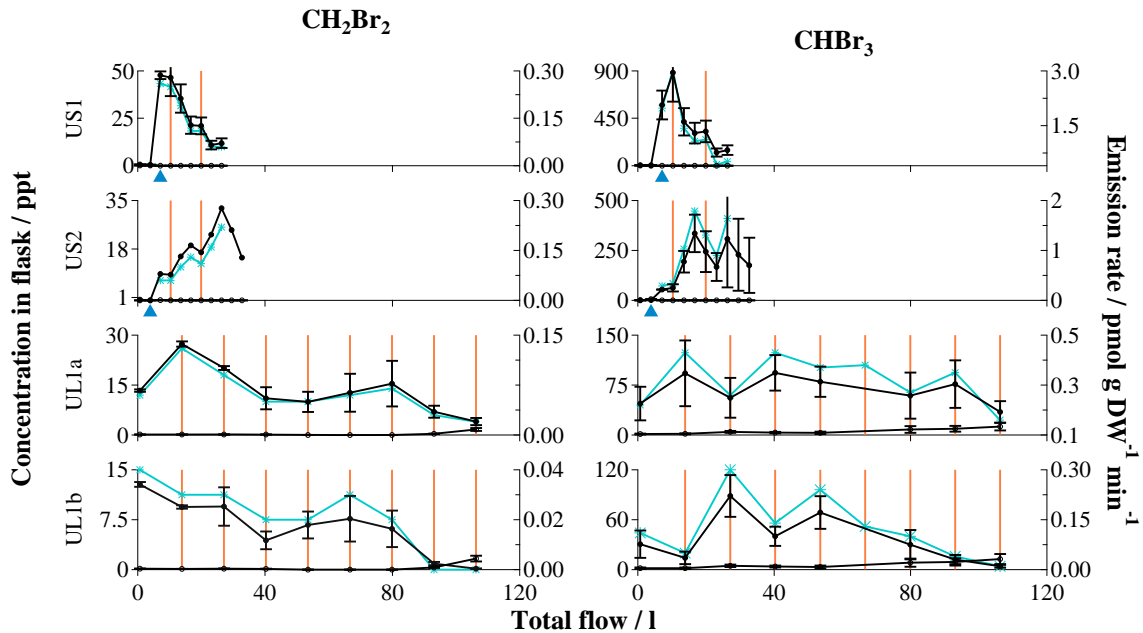

Figure 5. Bromocarbon concentrations (ppt, left axis) and production rates ($\text{pmol g DW}^{-1} \text{ min}^{-1}$, right axis) observed in flasks during desiccation of *U. intestinalis* (US and UL experiments). All other details are as for Fig. 4.

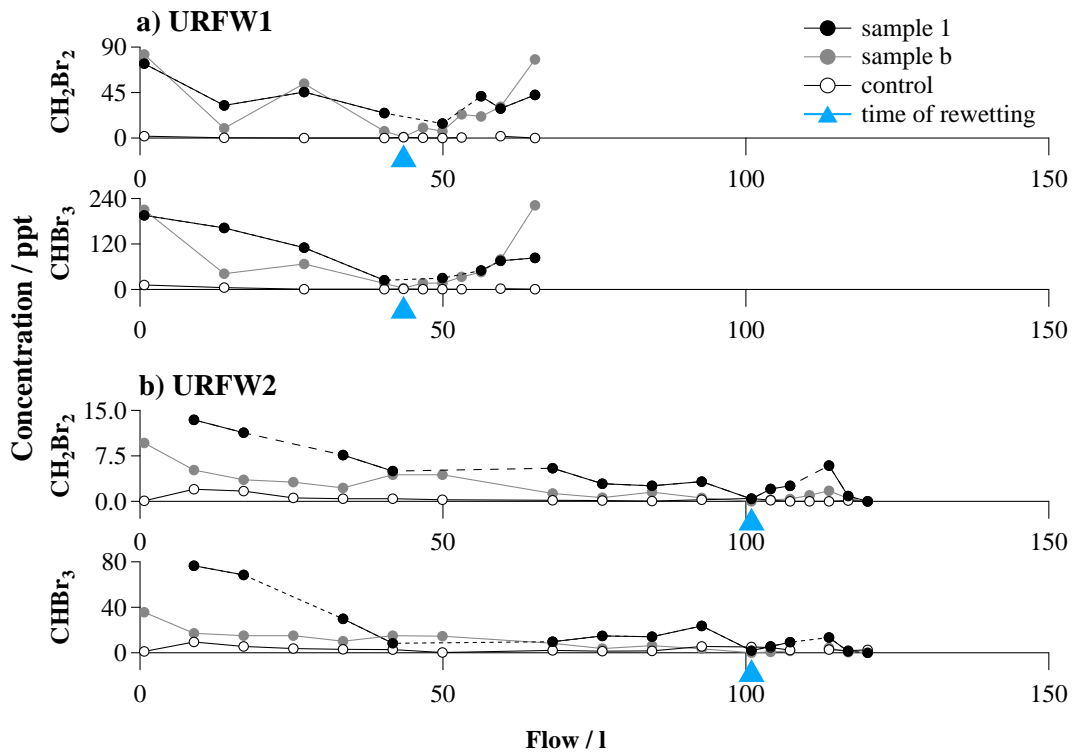

Figure 6. Desiccation of *U. intestinalis* followed by rewetting (URFW experiments). Changes are shown relative to total flow (L). Experiments conducted at different times are denoted by individual numbers (e.g. US1, US2). Within these experiments replicates in different flasks (Fig. 1) are denoted by individual letters (UL1a, UL1b), see Table 1 for further details. Error bars are taken from the daily variations in calibration standards.

2002). This result demonstrates that differences between in situ and laboratory conditions may affect experimental outcomes. It also provides a potentially interesting example of how artificial desiccation, for example during drying of harvested algae to create a market product, may vary from natural tidal desiccation. During commercial drying processes the algae are often spread into thin mats to increase the speed of drying and ensure drying occurs before onset of decay. This will increase the rate at which the algal biomass dries and so increase the rate of exposure to stress.

Our results are novel in combining F_v/F_m (photosynthetic capacity) time series measurements with halocarbon emissions. Overall patterns in F_v/F_m were similar between *F. vesiculosus* (FP1) and *U. intestinalis* (UP1 and UP2). During the first hour F_v/F_m values for all FP and the majority of UP1 and UP2 replicates showed F_v/F_m values that remained relatively constant or even increased slightly. This slight increase has been reported by others (Kumar et al., 2011; Peña et al., 1999), and has been attributed to a greater demand for energy by desiccation tolerance mechanisms or an increased availability of CO₂ as diffusion into the cell is enhanced. Decreases in F_v/F_m began after an hour for some replicates (e.g. in UP1). In other replicates large decreases were not noted until several hours into the experiment. One prior study reported F_v/F_m measurements during trace gas emission desiccation experiments, although their study focused on emissions of iodinated compounds from *L. digitata* (Nitschke et al., 2011). They measured at two time points only ($t = 0$ and 180 min). A significant decrease was seen in this time, although the magnitude of the decrease was small, 3%, compared to the decline we observed after further desiccation, supporting the idea that larger decreases in F_v/F_m do not begin until several hours of desiccating conditions. A decrease in F_v/F_m occurs as inorganic carbon becomes limited, oxidative damage affects the photosynthetic apparatus and electron flows between photosystem I (PSI) and PSII are interrupted (Kumar et al., 2011; Sampath-Wiley et al., 2008). Although *U. intestinalis* dried quicker than *F. vesiculosus*, decreases in F_v/F_m varied between experiments; decreasing quicker for *U. intestinalis* compared to *F. vesiculosus* in UP1 but not in UP2.

In many of the experiments the bromocarbon response to desiccation was a short-lived pulse of emissions that occurred within the first few hours of exposure and was not linked to declines in F_v/F_m . These results may suggest that existing bromocarbon stores are released during exposure rather than being produced as a direct response to oxidative stress. This supports recent findings by Küpper et al. (2013) who found iodide, not bromide, to be the major antioxidant in *L. digitata*. The prolonged emissions from *U. intestinalis* may be due to the fact it is known to produce higher quantities of CH₂Br₂ and CHBr₃ compared to *F. vesiculosus* and so might have greater bromocarbon reserves to release (Carpenter and Liss, 2000). As *U. intestinalis* has a faster rate of water loss during desiccation, volatilisation of halocar-

bons from the algal surface or surface water layer are likely to be greater. Also, as *U. intestinalis* may be subjected to a higher level of oxidative stress (due to the faster rate of water loss) and if bromocarbons do contribute to the antioxidant response their emissions are likely to be greater and more prolonged from *U. intestinalis* compared to *F. vesiculosus*.

Other possible causes for the decrease in bromocarbon emissions after the initial pulse, mainly halide or carbon/energy limitation, are unlikely to play a major role on the timescale of our experiments. As seaweeds concentrate halides from seawater in high concentrations (Saenko et al., 1978) halide limitation probably does not drive the observed decrease. A previous study on the rhodophyte *Stictosiphonia arbuscula* reported a decreasing ability to regenerate antioxidants (specifically the ascorbate-glutathione antioxidant response) when desiccation persisted for 12 h or more due to nutrient limitation (Burritt et al., 2002), a longer timescale than used in our experiments.

Rewetting in freshwater causes an extra osmotic stress to the cells (Lobban et al., 1985) and the results of the rewetting experiment UR1 suggest that bromocarbon emissions increase upon freshwater rewetting. It should be noted that *U. intestinalis* is a salinity-tolerant species found in a wide range of salinities in the natural environment (Edwards et al., 1988). Therefore the response of *U. intestinalis* to freshwater rewetting may not represent that of all species.

5 Conclusions

The emission of two important biogenic bromocarbons, CH₂Br₂ and CHBr₃, was observed during the desiccation of two common temperate macroalgae species, *F. vesiculosus* and *U. intestinalis*. A rapid pulse in bromocarbon emissions was seen within 10 min of exposure and, in most cases, either peaked or came to a plateau within 1–3 h or decreased immediately. In contrast, decreases in F_v/F_m only began 2.5 h into the desiccation period, and mass loss was steady throughout the experiments. From these results, we attribute the immediate pulse in bromocarbons to an emission or volatilisation of existing halocarbon stores from on or near the surface of the alga upon exposure. The rapid decrease in emissions suggests that bromocarbons may not be actively produced as a response to oxidative stress, in the same manner as iodocarbons and I₂, supporting previous studies (Küpper et al., 2013, 2008). The prolonged emissions of bromocarbons from *U. intestinalis* over 6–8 h could be due to a greater production of bromocarbons compared to *F. vesiculosus* (Carpenter and Liss, 2000) creating higher concentrations of bromocarbons at/near surface to be volatilised/emitted during desiccation.

Preliminary experiments investigating the impact of freshwater rewetting on bromocarbon emissions suggest that rewetting may lead to an increased emission of bromocarbons dependent on the length of exposure time prior to

rewetting. However, due to the high variability in natural emissions further experiments in this area are required.

Previously, we (Leedham et al., 2013) estimated annual emissions from tropical macroalgae aquaculture without taking into account emissions post-harvesting (mainly emissions from open-air drying). The results from this study suggest post-harvest desiccation may not greatly increase bromocarbon emission budgets from aquaculture. However, as our experiments ran for a maximum of 8 h, compared to several days of desiccation in an aquaculture environment, further investigation into the effects of long-term exposure is warranted.

Acknowledgements. E. Leedham was funded by a National Environmental Research Council (NERC) Ph.D. studentship (ID E66107B). The authors wish to thank Robert Utting for support with storage and maintenance of seaweed samples, Claire Hughes for initial training in the GCMS and Markes systems and Graham Mills, Johannes Laube and David Oram for assistance with the calibration standards.

Edited by: X. Wang

References

- Ball, S. M., Hollingsworth, A. M., Humbles, J., Leblanc, C., Potin, P., and McFiggans, G.: Spectroscopic studies of molecular iodine emitted into the gas phase by seaweed, *Atmos. Chem. Phys.*, 10, 6237–6254, doi:10.5194/acp-10-6237-2010, 2010.
- Bravo-Linares, C. M., Mudge, S. M., and Loyola-Sepulveda, R. H.: Production of volatile organic compounds (VOCs) by temperate macroalgae: The use of Solid Phase Microextraction (SPME) coupled to GC-MS as method of analysis, *J. Chilean Chem. Soc.*, 55, 227–232, doi:10.4067/S0717-97072010000200018, 2010.
- Burritt, D. J., Larkindale, J., and Hurd, C. L.: Antioxidant metabolism in the intertidal red seaweed *Stictosiphonia arbuscula* following desiccation, *Planta*, 215, 829–838, doi:10.1007/s00425-002-0805-6, 2002.
- Cainey, J. M., Keywood, M., Bigg, E. K., Grose, M. R., Gillett, R. W., and Meyey, M.: Flux chamber study of particle formation from *Durvillaea potatorum*, *Environ. Chem.*, 4, 151–154, doi:10.1071/EN07006, 2007.
- Carpenter, L. J. and Liss, P.: On temperate sources of bromoform and other reactive organic bromine gases, *J. Geophys. Res.*, 105, 20539–20547, doi:10.1029/2000JD900242, 2000.
- Carpenter, L. J., Sturges, W. T., Penkett, S. A., Liss, P. S., Alicke, B., Hebestreit, K., and Platt, U.: Short-lived alkyl iodides and bromides at Mace Head, Ireland: Links to biogenic sources and halogen oxide production, *J. Geophys. Res.*, 104, 1679–1689, doi:10.1029/98JD02746, 1999.
- Collén, J. and Davison, I. R.: Stress tolerance and reactive oxygen metabolism in the intertidal red seaweeds *Mastocarpus stellatus* and *Chondrus crispus*, *Plant. Cell Environ.*, 22, 1143–1151, doi:10.1046/j.1365-3040.1999.00477.x, 1999.
- Collén, J., Ekdahl, A., Abrahamsson, K., and Pedersén, M.: The involvement of hydrogen peroxide in the production of volatile halogenated compounds by *Meristiella gelidium*, *Phytochemistry*, 36, 1197–1202, doi:10.1016/S0031-9422(00)89637-5, 1994.
- Davison, I. R. and Pearson, G. A.: Stress tolerance in intertidal seaweeds, *J. Phycol.*, 32, 197–211, doi:10.1111/j.0022-3646.1996.00197.x, 1996.
- Edwards, D. M., Reed, R. H., and Stewart, W. D. P.: Osmoacclimation in *Enteromorpha intestinalis*: Long-term effects of osmotic stress on organic solute accumulation, *Mar. Biol.*, 98, 467–476, doi:10.1007/BF00391537, 1988.
- Goodwin, K. D., North, W. J., and Lidstrom, M. E.: Production of bromoform and dibromomethane by Giant Kelp: Factors affecting release and comparison to anthropogenic bromine sources, *Limnol. Oceanogr.*, 42, 1725–1734, doi:10.4319/lo.1997.42.8.1725, 1997.
- Gschwend, P. M., MacFarlane, J. K., and Newman, K. A.: Volatile halogenated organic compounds released to seawater from temperate marine macroalgae, *Science*, 227, 1033–1035, doi:10.1126/science.227.4690.1033, 1984.
- Hughes, C., Chuck, A. L., Rossetti, H., Mann, P. J., Turner, S. M., Clarke, A., Chance, R., and Liss, P. S.: Seasonal cycle of seawater bromoform and dibromomethane concentrations in a coastal bay on the western Antarctic Peninsula, *Global Biogeochem. Cy.*, 23, GB2024, doi:10.1029/2008GB003268, 2009.
- Hughes, C., Johnson, M., von Glasow, R., Chance, R., Atkinson, H., Souster, T., Lee, G. A., Clarke, A., Meredith, M., Venables, H. J., Turner, S. M., Malin, G., and Liss, P. S.: Climate-induced change in biogenic bromine emissions from the Antarctic marine biosphere, *Global Biogeochem. Cy.*, 26, GB3019, doi:10.1029/2012GB004295, 2012.
- Ji, Y. and Tanaka, J.: Effect of desiccation on the photosynthesis of seaweeds from the intertidal zone in Honshu, Japan. *Phycol. Res.*, 50, 145–153, doi:10.1046/j.1440-1835.2002.00268.x, 2002.
- Jones, C. E., Hornsby, K. E., Dunk, R. M., Leigh, R. J., and Carpenter, L. J.: Coastal measurements of short-lived reactive iodocarbons and bromocarbons at Roscoff, Brittany during the RHaMBLE campaign, *Atmos. Chem. Phys.*, 9, 8757–8769, doi:10.5194/acp-9-8757-2009, 2009.
- Keng, F. S.-L., Phang, S.-M., Rahman, N. A., Leedham, E. C., Hughes, C., Robinson, A. D., Harris, N. R. P., Pyle, J. A., and Sturges, W. T.: Volatile halocarbon emissions by three tropical brown seaweeds under different irradiances, *J. Appl. Phycol.*, 25, 1377–1386, doi:10.1007/s10811-013-9990-x, 2013.
- Klick, S.: The release of volatile halocarbons to seawater by untreated and heavy metal exposed samples of the brown seaweed *Fucus vesiculosus*, *Mar. Chem.*, 42, 211–221, doi:10.1016/0304-4203(93)90013-E, 1993.
- Kumar, M., Gupta, V., Trivedi, N., Kumari, P., Bijo, A. J., Reddy, C. R. K., and Jha, B.: Desiccation induced oxidative stress and its biochemical responses in intertidal red alga *Gracilaria corticata* (Gracilariales, Rhodophyta), *Environ. Exp. Bot.*, 72, 194–201, doi:10.1016/j.envexpbot.2011.03.007, 2011.
- Küpper, F. C., Kloareg, B., Guern, J., and Potin, P.: Oligoguluronates elicit an oxidative burst in the brown algal kelp *Laminaria digitata*, *Plant Physiol.*, 125, 278–291, doi:10.1104/pp.125.1.278, 2001.
- Küpper, F. C., Carpenter, L. J., McFiggans, G. B., Palmer, C. J., Waite, T. J., Boneberg, E. M., Woitsch, S., Weiller, M., Abela, R.,

- Grolimund, D., Potin, P., Butler, A., Luther III, G. W., Kronek, P. M. H., Meyer-Klaucke, W., and Feiters, M. C.: Iodine accumulation provides kelp with an inorganic antioxidant impacting atmospheric chemistry, *P. Natl. Acad. Sci. USA*, 105, 6954–6958, doi:10.1073/pnas.0709959105, 2008.
- Küpper, F. C., Carpenter, L. J., Leblanc, C., Toyama, C., Uchida, Y., Maskrey, B. H., Robinson, J., Vergaeghe, E. F., Malin, G., Luther III, G. W., Kronek, P. M. H., Kloareg, B., Meyer-Klaucke, W., Muramatsu, Y., Megson, I. L., Potin, P., and Feiters, M. C.: In vivo speciation studies and antioxidant properties of bromine in *Laminaria digitata* reinforce the significance of iodine accumulation for kelps, *J. Exp. Bot.*, 64, 2653–2664, doi:10.1093/jxb/ert110, 2013.
- Leedham, E. C., Hughes, C., Keng, F. S. L., Phang, S.-M., Malin, G., and Sturges, W. T.: Emission of atmospherically significant halocarbons by naturally occurring and farmed tropical macroalgae, *Biogeosciences*, 10, 3615–3633, doi:10.5194/bg-10-3615-2013, 2013.
- Leedham Elvidge, E. C., Oram, D. E., Laube, J. C., Baker, A. K., Montzka, S. A., Humphrey, S., O'Sullivan, D. A., and Brenninkmeijer, C. A. M.: Increasing concentrations of dichloromethane, CH₂Cl₂, inferred from CARIBIC air samples collected 1998–2012, *Atmos. Chem. Phys. Discuss.*, 14, 20721–20765, doi:10.5194/acpd-14-20721-2014, 2014.
- Lesser, M. P.: Oxidative stress in marine environments: Biochemistry and physiological ecology, *Annu. Rev. Physiol.*, 68, 253–278, doi:10.1146/annurev.physiol.68.040104.110001, 2006.
- Lewis, S., Donkin, M. E., and Depledge, M. H.: Hsp70 expression in *Enteromorpha intestinalis* (Chlorophyta) exposed to environmental stressors, *Aquat. Toxicol.*, 51, 277–291, doi:10.1016/S0166-445X(00)00119-3, 2001.
- Lobban, C. S., Harrison, P. J., and Duncan, M. J.: *Seashore Communities. The Physiological Ecology of Seaweed*, Cambridge University Press, New York, 154–188, 1985.
- Lüning, K.: *Seaweeds, Their environment, biogeography and ecophysiology*, John Wiley & Sons, Inc., New York, 1990.
- Magnusson, G.: Diurnal measurements of F_v/F_m used to improve productivity estimates in macroalgae, *Mar. Biol.*, 130, 203–208, doi:10.1007/s002270050239, 1997.
- Mäkelä, J. M., Hoffmann, T., Holzke, C., Väkevä, M., Suni, T., Mattila, T., Aalto, P. P., Tapper, U., Kauppinen, E. I., and O'Dowd, C. D.: Biogenic iodine emissions and identification of end-products in coastal ultrafine particles during nucleation bursts, *J. Geophys. Res.*, 107, 8110, doi:10.1029/2001JD000580, 2002.
- Manley, S.: Phytogenesis of halomethanes: A product of selection or a metabolic accident?, *Biogeochemistry*, 60, 163–180, 2002.
- Markes International: Thermal Desorption Technical Support Note 5: Advice on sorbent selection, tube conditioning, tube storage and air sampling, Markes; UK, 2008.
- Markes International: Thermal Desorption Technical Note 20: Confirming sorbent tube retention volumes and checking for analyte breakthrough, Markes; UK, 2012.
- McFiggans, G., Coe, H., Burgess, R., Allan, J., Cubison, M., Alfarra, M. R., Saunders, R., Saiz-Lopez, A., Plane, J. M. C., Wevill, D., Carpenter, L., Rickard, A. R., and Monks, P. S.: Direct evidence for coastal iodine particles from *Laminaria* macroalgae – linkage to emissions of molecular iodine, *Atmos. Chem. Phys.*, 4, 701–713, doi:10.5194/acp-4-701-2004, 2004.
- Montzka, S. A., Reimann, S., et al.: Chapter 1, Ozone-Depleting Substances (ODSs) and Related Chemicals, in: *Scientific Assessment of Ozone Depletion: 2010, Global Ozone Research and Monitoring Project Report No. 52*, World Meteorological Organisation; Geneva, 2010.
- Nightingale, P. D., Malin, G., and Liss, P. S.: Production of chloroform and other low molecular-weight halocarbons by some species of macroalgae, *Limnol. Oceanogr.*, 40, 680–689, doi:10.4319/lo.1995.40.4.0680, 1995.
- Nitschke, U., Ruth, A. A., Dixneuf, S., and Stengel, D. B.: Molecular iodine emission rates and photosynthetic performance of different thallus parts of *Laminaria digitata* (Phaeophyceae) during emersion, *Planta*, 233, 737–748, doi:10.1007/s00425-010-1334-3, 2011.
- Palmer, C. J., Anders, T. L., Carpenter, L. J., Küpper, F. C., and McFiggans, G. B.: Iodine and halocarbon response of *Laminaria digitata* to oxidative stress and links to atmospheric new particle production, *Environ. Chem.*, 2, 282–290, doi:10.1071/EN05078, 2005.
- Pearson, G., Kautsky, L., and Serrão, E.: Recent evolution in Baltic *Fucus vesiculosus*: Reduced tolerance to emersion stresses compared to intertidal (North Sea) populations, *Mar. Ecol. Prog. Ser.*, 202, 67–79, doi:10.3354/meps202067, 2000.
- Pedersén, M., Collén, J., Abrahamsson, K., and Ekdahl, A.: Production of halocarbons from seaweeds an oxidative stress reaction?, *Scientia Marina* 60, 257–263, 1996.
- Pena, E. J., Zingmark, R., and Nietch, C.: Comparative photosynthesis of two species of intertidal epiphytic macroalgae on mangrove roots during submersion and emersion, *J. Phycol.*, 35, 1206–1214, doi:10.1046/j.1529-8817.1999.3561206.x, 1999.
- Saenko, G. N., Kravtsova, Y. Y., Ivanenko, V. V., and Sheludko, S. I.: Concentration of iodine and bromine by plants in the Seas of Japan and Okhotsk, *Mar. Biol.*, 47, 243–250, doi:10.1007/BF00541002, 1978.
- Sampath-Wiley, P., Neefus, C. D., and Jahnke, L. S.: Seasonal effects of sun exposure and emersion on intertidal seaweed physiology: Fluctuations in antioxidant contents, photosynthetic pigments and photosynthetic efficiency in the red alga *Porphyra umbilicalis* Kützting (Rhodophyta, Bangiales), *J. Exp. Mar. Biol. Ecol.*, 361, 83–91, doi:10.1016/j.jembe.2008.05.001, 2008.
- Schlarb-Ridley, B. and Parker, B.: A UK roadmap for algal technologies. Report for the National Environmental Research Council (NERC) Technology Strategy Board (TSB) Algal Bioenergy-Special Interest Group (AB-SIG), 2013.
- Waltz GmbH: *Underwater fluorometer Diving-PAM Submersible Photosynthesis Yield Analyzer – Handbook of Operation*, Waltz; Germany, 1998.
- Williams, S. L. and Dethier, M. N.: High and dry: Variation in net photosynthesis of the intertidal seaweed *Fucus gardneri*, *Ecology*, 86, 2373–2379, doi:10.1890/04-1569, 2005.