

Efficient Hardware Architecture for Cyclostationary Detector

D Damodaram^{*1}, T Venkateswarlu²

¹Department of ECE, Sree Vidyanikethan Engineering College, Tirupati, India

²Department of ECE, S.V. University College of Engineering, Tirupati, India

*Corresponding author, e-mail: damu_dk@rediffmail.com¹, warlu57@gmail.com²

Abstract

Cognitive radio is one of the modern techniques which is evolved for utilising the unused spread spectrum effectively in wireless communication. In cognitive radio system the foremost concept is sensing the holes (spaces) in the frequency spectrum allotted and it facilitates a way that how effectively and efficiently the bandwidth is used by finding the spectrum holes in a designated spectrum. There are various methods available for sensing the spectrum and one such a sensing method is cyclostationary detection. The method of cyclostationary feature mainly focuses on detecting whether the primary user is present or absent. The threshold of a signal is calculated by cyclic cross-periodogram matrix of the corresponding signal to determine the presence of signal or noise. The difficulty in evaluating the targeted threshold is evaded by training an artificial neural network by extracted cyclostationary feature vectors which are obtained by FFT accumulation method. This paper proposes a hardware architecture for cyclostationary detection.

Keywords: Cognitive radio, cyclostationary, Spectrum Sensing, FFT accumulation method, neural network

1. Introduction

Present decades, there is heavy demand and increase number of users in wireless communication systems. The usage of frequency bands, or spectrum, is strongly regulated and allocated to specific communication technologies. The enormous majority of frequency bands are allocated to licensed users, which are also steered by standards. There are several organizations working on standards [1] for frequency allocation, such as the European Telecommunications Standards Institute (ETSI), the International Telecommunication Union (ITU) and the European Conference of Postal and Telecommunications Administrations (CEPT).

According to OFCOM consultation report [2], a substantial amount of spectrum termed as “white space” is obtainable subjected to time and site basis. The report outlines that over 50% of locations are likely to have more than 150 MHz of spectrum interleaved and that even at 90% of locations around 100 MHz of interleaved spectrum might be available. In addition, the shifting to the Digital Terrestrial Television (DTT) eases for OFCOM to clear many bands such as the 800 MHz (channels 61-69) for future cognitive radios.

One of the major issues in the cognitive radio technology is spectrum sensing. In cognitive radios, the system recognizes the electromagnetic environment by sensing the spectrum. At the Royal Institute of Technology in Stockholm, in the year 1998, Sir Joseph Mitola III [3] has conceived the concept of cognitive radio. Since then Cognitive Radio has become solution to the crowded spectrum problem by introducing the opportunistic usage of the frequency bands [4]. Provided the licensed users should not have occupied these frequency bands. The components in the cognitive radio have the ability to measure, sense, learn the parameters related to the radio channel [5] [6] and also have the information regarding the availability of radio spectrum, power, the user requirements, applications and also its operating restrictions. In the dialect of cognitive radio, the primary user (PU) is the user who has higher priority on the usage of allotted frequency spectrum. Secondary user is the user who has lower priority.

The secondary user should access the spectrum in such a way that it does not create any sort of interference to the existing primary user. The secondary user too will have the cognitive radio capabilities, like sensing whether the spectrum band is being used by any

primary user and also to change its own radio parameters in order to utilise the unused band spectrum hole. If the spectrum sensing is not done properly, the cognitive radio system gives inaccurate information about the radio environment, and the system will try to use the spectrum which a primary user uses and does not use the spectrum which the primary user is not utilising. There by causing interference to the primary user. This results in several performance degradation of the cognitive radio system and the primary user [7].

Many researchers believe that cyclostationary feature detection is more suitable choice than matched filter and energy detector techniques [8]. The matched filter detector which is a coherent type detector requires prior knowledge about primary user's waveform. A non-coherent energy detector does not require any such sort of prior knowledge about waveforms. It measures energy in each narrowband channel and determines the presence of a primary user if the energy detected in a narrow band channel is higher than a certain threshold. However, to achieve high receiver sensitivity, a low threshold has to be used. In some cases, the threshold has to be lower than the noise floor, in which case the detection fails. Because of the presence of CR user's interference, the noise is most likely nonGaussian and this makes the problem more complicated. Even if it is easy to implement energy detector, it is highly prone to in-band interference and changing the noise levels [9] and it cannot differentiate between signal power and noise power.

Most of the signals encountered in wireless communications are cyclostationary, whereas the noise is stationary. The wireless communication signals loaded with sinusoidal carriers, pulse trains, repeating codes, hopping sequences, cyclic prefixes, and signals are cyclostationary as their mean value and autocorrelation function exhibits periodicity. This periodicity is used to perform several signal processing tasks such as detection, recognition and estimation of the signals that are received [10]. The block diagram of cyclostationary detection is shown in Figure 1.



Figure 1. Block diagram of cyclostationary detection

In cyclostationary process, the statistical properties like mean and autocorrelation changes periodically with time and this is caused due to modulation, coding in a particular signal and it always exhibits regenerative periodicity which is the characteristic property of cyclostationary process [6]. 2 mainly used methods to realize cyclostationary feature detection are [1]:

- a. FFT Accumulation Method (FAM).
- b. Striped Spectrum Correlation Method (SSCM).

These two methods will give results in a matrix form which represents time smoothed cyclic cross periodogram. The amount of correlation values corresponding to the signal is present in the cross periodogram. The signal or noise which is given as input to the detector is found by the matrix. Both the sampling rate and the cyclic frequency resolution will decide size of the matrix. An artificial neural network (ANN) is used to predict the threshold value. An ANN is a network formed by interconnection of neurons. The threshold of a cyclic cross periodogram of a cyclostationary feature detection process is predicted by ANN and a discrete sample of signal is used as an input for cyclostationary feature detection process.

2. Spectrum Sensing

Cognitive radio spectrum sensing system model is considered as a kind of signal detection which has been probed for quite a few years. According to the signal detection theory [12], spectrum sensing of CR is system modelled and expressed as follows.

Let $x(n)=s(n)+w(n)$ stand for the received signal of a primary user, considering channel with path loss, multipath fading and time dispersions, where $s(n)$ is the possible primary user's signal and $w(n)$ is the noise. Spectrum sensing can be considered as a binary hypothesis testing problem with:

$$H_0 : x(n)=w(n) \quad (1)$$

$$H_1 : x(n)=s(n)+ w(n) \quad (2)$$

Where H_0 represents the hypothesis that the primary user's signal is absent, H_1 represents the hypothesis that the primary user's signal is present, and $n=1, 2, \dots, N$ are indices of N signal samples.

The important parameters to measure the performance of Spectrum detection are probability of miss detection (P_{md}) and probability of false alarm (P_f). Miss detection appears when a busy channel is found as idle, which means at hypothesis H_1 . The false alarm appears if an idle channel is found as busy, which means that the probability of the detector having detected the signal (H_0). The following definitions holds good:

$$P_{md}=P_r (H_0/H_1) \quad (3)$$

$$P_f=P_r (H_0/H_1) \quad (4)$$

The probability of detection, P_d , is defined as

$$P_d=P_r (H_1/H_1)=(1- P_{md}) \quad (5)$$

Spectrum sensing time is another important parameter to be considered for the analysis. When the PUs come back to use their spectrum there should not be any interference. So, the detection time should be maintained as short as possible. IEEE 802.22 standard on cognitive radio has formulised on the sensing time, that it should be not more than two seconds. Frequency resolution, bandwidth, power and area consumption are the other essential implementation parameters which to be considered.

3. Cyclostationary Feature Detection Algorithm

Since the data is a stationary random signal and the signal is modulated. The modulated signal is characterized as cyclostationary because their mean and autocorrelation exhibit periodicity. This algorithm can able to detect the modulated random signal with a particular type of background noise. Signal $x(t)$ is considered to be second order cyclostationary, if its mean and autocorrelation are periodic with a period T_0 , i.e.:

$$M_x (t+T_0)=M_x(t) \quad (6)$$

$$R_x (t+T_0,\tau)=R_x (t,\tau) \quad (7)$$

Then, the periodic function $R_x (t,\tau)$ can be further expressed as follows

$$R_x(t, \tau) = \sum_{n=-\infty}^{n=+\infty} R_x^{\frac{n}{T_0}}(\tau) e^{j2\pi\frac{n}{T_0}t} \quad (8)$$

The above function is known as cyclic autocorrelation functions. Let α represent the frequencies $\{n/T_0\}_{n \in \mathbb{Z}}$, which is referred to as cycle frequency. From the Fourier transform of the cyclic autocorrelation function (6) the spectral correlation density (SCD), or cyclic spectral density, can be obtained as

$$S_x^\alpha(f) = \int_{-\infty}^{\infty} R_x^\alpha(\tau) e^{i2\pi f\tau} d\tau \quad (9)$$

Since the signals being analyzed are defined over a finite time interval Δt , the cyclic spectral density is only an estimation. Time smoothing and frequency smoothing methods are used to estimate the cyclic spectral density or SCD. For general cyclic spectral analysis time smoothing algorithms are considered to be more computationally efficient [5]. An estimate of the SCD can be obtained by the time-smoothed cyclic periodogram given by

$$S_x^\alpha(f) = S_{x_{TW}}^\alpha(t, f)_{\Delta t} \tag{10}$$

Where Δt is the total observation time of the signal. The cycle frequency resolution of the estimation, $\Delta\alpha$, is determined by $\Delta\alpha=1/\Delta t$. Where TW is the short-time FFT window length. The spectral components generated by each short-time Fourier transform have a resolution of $\Delta f=1/TW$. In addition, there is an overlap factor, denoted by L , between each short-time FFT.

The FFT accumulation method which is a time-smoothing algorithm is proved to be computationally effectual than frequency-smoothing algorithms. For the time discrete expressions of SCD, we define the sampled signal

$$x(n) = x(n \cdot \frac{1}{f_s}) \tag{11}$$

Where f_s indicates the sampling frequency. Furthermore, we assume parameter N ($n=1, 2...N$) represents the total number of discrete samples within the observation time. The figure 2 gives the block diagram for Principle of cyclostationary Detector.

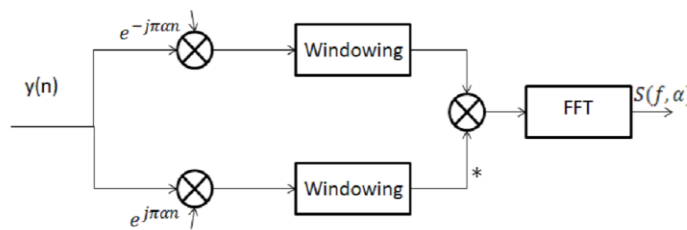

Figure 2. Principle of cyclostationary detector

To find out whether the signal is present or not by means of threshold value, we employ neural network to optimize the value. The ANNs are represented by the general form of a neuron which consists of n number of inputs along with weights of each input. The actual functionality of a neuron is represented by the summation part [12]. The output of the summation is fed to an activation function which usually depends on the application. The figure 3 shows the general representation of neural network.

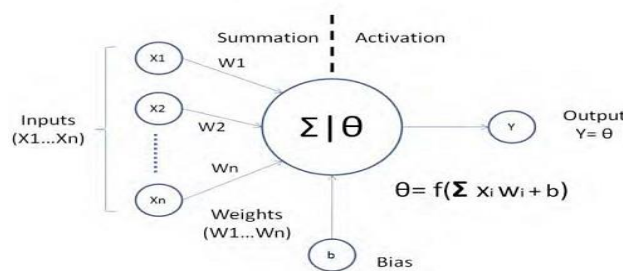

Figure 3. Representation of a Neuron with n number of inputs, weights of each input and activation function

For the back propagation neural network application, the most frequently used activation function is the hyperbolic tangent (tanh) sigmoid function (referred to as "tansig" in Matlab) [13, 14]. The figure 4 gives the back propagation neural network

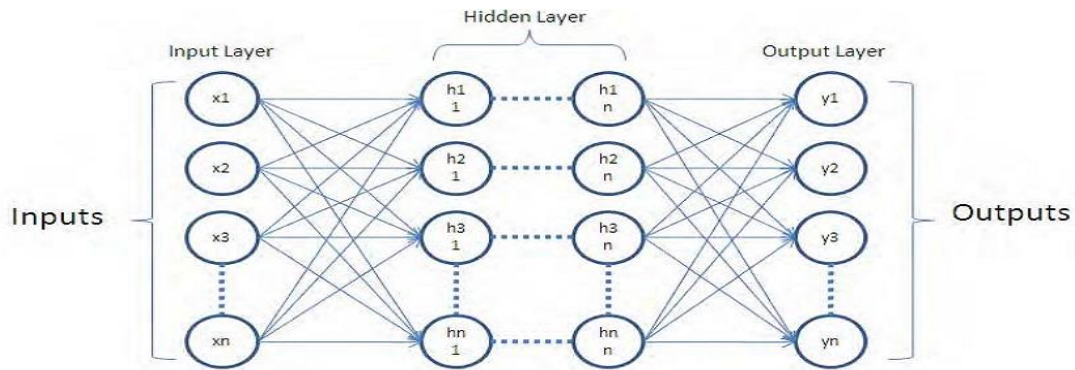

Figure 4. An artificial neural network model along with n inputs, hidden and output layers

The sigmoid function is given below

$$f(n) = \frac{e^n - e^{-n}}{e^n + e^{-n}} \tag{12}$$

The error is calculated as per the following equation

$$E = \sum_i E_i \tag{13}$$

$$E_i = 1/2 \sum_i (t_i - y_i)^2 \tag{14}$$

Where E_i represents the error due to single output y_n and corresponding target t_n and E represents the summation of all the errors. The weights are updated after the error calculation by using the following method.

$$\Delta W_i = \epsilon ((t_i - y_i) x_i) \tag{15}$$

$$W_i = W_i - \Delta W_i \tag{16}$$

Where ΔW_i represents the change in weight of the i^{th} connection corresponding to the input x_i and W_i is the value of the old weight. $\epsilon > 0$ represents the learning rate involved in calculation of weight change.

4. Hardware Implementation of Cyclostationary Detection Algorithm

Cyclostationary signals exhibit correlation function between widely separated spectral components due to the spectral redundancy caused by the periodicity of the modulated signal [11]. Executing with IEEE 802.11a signal as its input to FFT accumulation method the cyclic cross periodogram was obtained and the operating frequency of 5 GHz. Cyclostationary feature detection is described by the following steps:

Determine the points of cyclic frequency, the complex envelopes are estimated efficiently by means of a sliding N' point FFT, followed by a downshift in frequency to baseband. Sliding windows are very useful in the analysis of dominant cyclic features. In our simulations we decided to use Rectangular window.

A Fourier Transform of these windowed signals is conducted to continue the computation in the frequency domain. The Spectral Correlation Function is computed for each

frame, and then normalize by taking its mean. Using the spectral correlation function we can detect the primary user.

We consider OFDM signals scheme. This scheme contains 64 sub-carrier out of which 52 are pilot and data subcarriers, 11 are guard sub-carriers and 1 is DC null. In total 64 points FFT is considered. There are 4 pilot subcarriers out of 64 subcarriers and the data subcarriers are present at the positions other than pilot subcarriers. The index point 0 is the DC null. Figure 5 gives the FFT Accumulation method architecture.

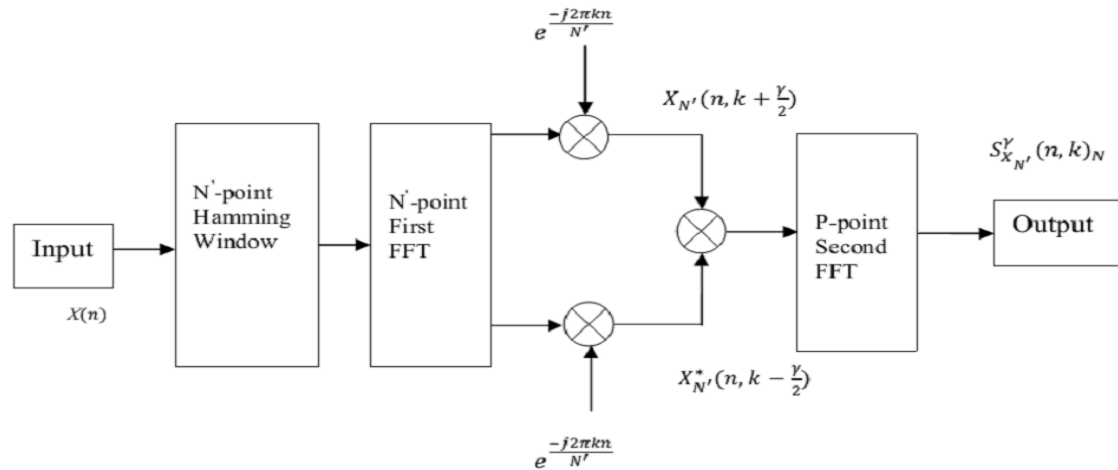

Figure 5. Architecture of FFT Accumulation method

The FAM is implemented by forming a two dimensional arrays from $X(kT)$, where k varies from 0 to $N-1$. In this, the columns representing constant frequencies which are obtained by applying Hamming window to the input, Fast Fourier Transformed and then down converted to baseband.

The major hardware part of the cyclostationary detection algorithm is FFT. The design pipelined FFT hardware architectures of radix- 2^2 was a milestone. Then, radix- 2^2 was extended to radix- 2^k . Moreover, there are many designs proposed for radix- 2^k single-path delay feedback (SDF) architectures, but many designs are not proposed for feedforward ones which is called multi-path delay commutator (MDC). We are proposing radix- 2^k feedforward (MDC) FFT architectures for this application. In feedforward architectures radix- 2^k can be used for any number of parallel samples which is a power of two. The proposed designs very high throughputs can be achieved, which enables them to suit for high speed applications. When several samples in parallel are to be processed, it requires a few hardware resources than parallel feedback ones. The proposed 64 point FFT architecture is shown in the figure 6. These architectures are meant to be more hardware-efficient and make them very attractive for the computation of the FFT.

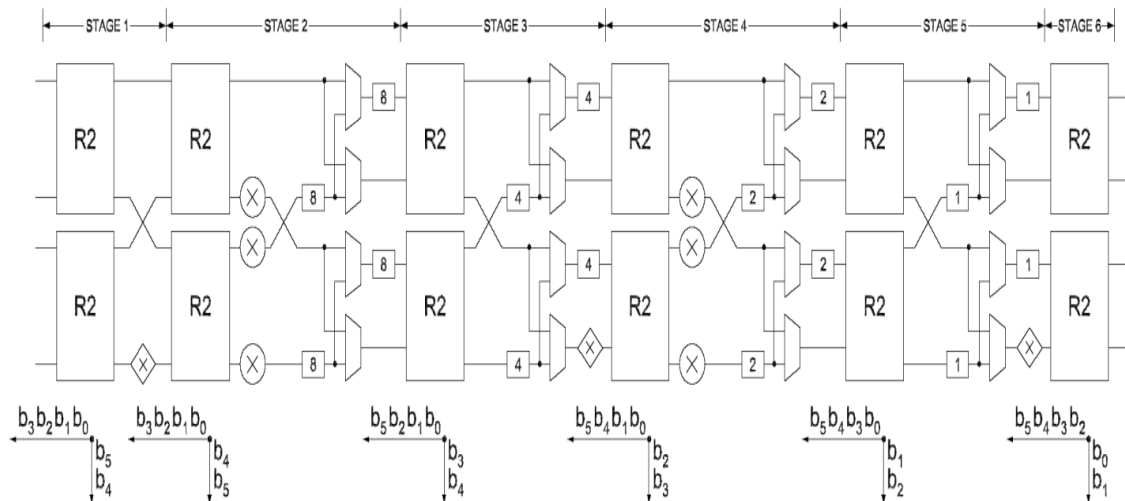

Figure 6. Proposed 64 point feedforward architecture

5. Conclusion

In this paper, to predict the thresholds an artificial neural network has been trained from the features of cross-periodogram matrix of signal statistics. FFT accumulation method has been implored for detecting the presence of signal or noise. The proposed ANN Scheme clearly indicates the strength of the artificial neural network to detect the presence of spectrum holes. The proposed hardware architecture will improve the performance of the detector. Prediction of threshold using data sets of different noise strength to test the efficiency of the neural network schemes and support vector machine to provide better classification accuracy for increased noisy data will be included in Future work.

References

- [1] Federal Communications Commission (FCC) — Spectrum Policy Task Force Report. 2002: 2: 135.
- [2] OFCOM. "Digital dividend: cognitive access". Consultation on licence-exempting cognitive devices using interleaved spectrum, Publication date: 16 February 2009.
- [3] J Mitola III, GQ Maquire Jr. "Cognitive radio: Making software radios more personal". *IEEE Personal Communications*. 1999; 6(4): 13–18.
- [4] S Haykin. "Cognitive Dynamic Systems". *Proceedings of IEEE*. 2006; 94(11): 1910-1911.
- [5] Dy SPAN. "Radio Applications". In proceeding of *IEEE Dynamic Spectrum Access Networks*. 2005: 124–130.
- [6] E Blossom. "GNU radio: tools for exploring the radio frequency spectrum". *Linux Journal*. 2004; 122.
- [7] W Lee, Dong-Ho Cho. "Sensing Optimization Considering Sensing Capability of Cognitive Terminal in Cognitive Radio System". 3rd Int. Conference on Cognitive Radio oriented Wireless Networks & Communications, CrownCom 2008. 2008: 1-6.
- [8] T Yucek, H Arslan. "A survey of spectrum sensing algorithms for cognitive radio applications". *IEEE Communications Surveys Tutorials*. 2009; 11(1): 116-130.
- [9] Saman Atapattu, Chintha Tellambura and Hai Jiang. "Energy Detection Based Cooperative Spectrum Sensing in Cognitive Radio Networks". *IEEE Transactions on Wireless Communications*. 2011; 10(4): 1232-1241.
- [10] J Chen, A Gibson, J Zafara. "Cyclostationary Spectrum Detection in Cognitive Radios". *IET Seminar on Cognitive Radio and Software Defined Radio*. 2008: 1-5.
- [11] K Po, J Takada. "Signal Detection based on Cyclic Spectrum Estimation for Cognitive Radio". *IEEE 802.22 WRAN System, IEICE Technical Reports*. 2007; 106(558): 15-19.
- [12] A Fehske, JD Gaeddert, JH Reed. "A New Approach to Signal Classification Using Spectral Correlation and Neural Networks". in *Proc. IEEE DySPAN*. 2005: 144-150.
- [13] Vamsi Krishna Tumuluru, Ping Wang, Dusit Niyato. "A Neural Network Based Spectrum Prediction Scheme for Cognitive Radio". *IEEE international conference ICC*. 2010: 1-5.
- [14] Liang Yin, Si Xing Yin, Weijun Hong, Shu Fang Li. "Spectrum Behavior Learning in Cognitive Radio Based on Artificial Neural Network". *Military communication conference MILCOM*. 2011: 25-30.