

Fuzzy Logic Based Direct Power Control of Induction Motor Drive

Hossein Rahimi Khoei^{*1}, Elham Farazande Shahraki²

¹Faculty of Electrical Engineering, Technical and Professional University Shahrekord, Shahrekord, Iran

²Shahid Beheshti University, Tehran, Iran

*Corresponding author, e-mail: hrahimi174@yahoo.com

Abstract

This paper is the design of an induction motor drive system that can be controlled using direct power control. First the possibilities of direct power control (DPC) of induction motors (IMs) fed by a voltage source inverter have been studied. Principles of this method have been separately evaluated. Also the drive system is more versatile due to its small size and low cost. Therefore it is advantageous to use the system where the speed is estimated by means of a control algorithm instead of measuring. This paper proposed one novel induction motor speed control system with fuzzy logic. The estimator was designed and simulated in Matlab/Simulink. Simulation result shows a good performance of speed estimator.

Keywords: Direct Power Control (DPC), Fuzzy Logic, Induction Motor (IM)

1. Introduction

The electric drive system is a vital part to drive any motor. The electric drive system is used to control the position, speed and torque of the electric motors. Many works has been done on power converter topologies, control scheme of the electric drive systems and on the motor types in order to enhance and improve the performance of the electric motors so as to exactly perform and do what is required [1]. Induction Motors (IMs) are widely used in industrial, commercial and domestic applications as they are simple, rugged, low cost and easy to maintain. Since IMs demands well control performances: precise and quick torque and flux response, large torque at low speed, wide speed range, the drive control system is necessary for IMs [2].

Control of the Induction motors can be done using various techniques. Most common techniques are: (a) constant voltage/frequency control (V/F), (b) field orientation control (FOC), and (c) direct torque control (DTC). The first one is considered as scalar control since it adjusts only magnitude and frequency of the voltage or current with no concern about the instantaneous values of motor quantities. It does not require knowledge of parameters of the motor, and it is an open-loop control. Thus, it is a low cost simple solution for low-performance applications such as fans and pumps. The other two methods are in the space vector control category because they utilize both magnitude and angular position of space vectors of motor variables, such as the voltage and flux. They are employed in high performance applications, such as positioning drives or electric vehicles [3, 4].

Direct power control is a control method that directly selects output voltage vector states based on the power and flux errors using hysteresis controllers and without using current loops. In this respect, it is similar to the well know direct torque control (DTC) method described in the literatures for various AC motors [5].

What is in common among these applications is that they all are power output devices needed to provide real power to the load. DPC technique basically is applied to generators, but it has been tried to employ it to control of electrical motors instead of DTC technique, due to problems of torque estimation and dependency to the motor's parameters in DTC. Therefore, DPC technique enjoys all advantages of DTC such as fast dynamic and ease of implementation, without having the DTC's problems. However, publications about direct power control are mainly aimed at either rectifiers [6], converters [7, 8], dual-fed induction generators (DFIG) [9, 10] or permanent magnet synchronous generators (PMSG) [11, 12], and there isn't any research about using the DPC technique for Induction motor.

The research of induction motor speed has been an important field of research of drive system. The main reasons for the development of drives are: reduction of complex hardware and hence cost; increase in mechanical robustness and hence overall ruggedness; working under hostile environment; higher reliability; reduced maintain etc. Techniques range open loop, low performance strategy to closed loop, high performance over the past decades [13-17].

Since last decade, fuzzy logic control has gained significant attention in the field of control system applications but has not been applied much for the speed estimation solutions [18-22].

In this paper, to reduce the torque ripples of the induction motor on the DPC method, a new approach has been proposed which named as, fuzzy logic based space vector modulation method. The fuzzy logic controller, in this proposed method, rates of flux and power errors as input and describes optimum space vector as output to minimize flux and power errors.

2. Direct Power and Flux Control of Induction Motors

The direct power control methods discussed in this paper bear certain similarity to the direct torque control (DTC). Therefore, DPC is actually direct power and flux control, with two parameters involved in the control strategy, so it is also named as direct power and flux control (DPFC) in some publications [24].

Direct power and flux control (DPFC) of IMs is a control method that directly selects output voltage vector states based on the power and flux errors using hysteresis controllers. Figure 1 shows the block diagram of a general open-loop DPFC system.

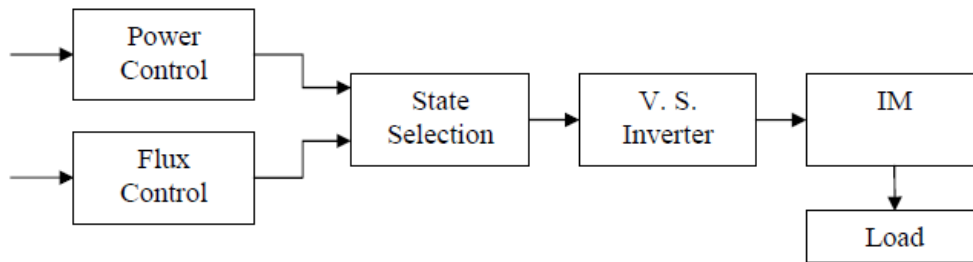

Figure 1. Block diagram of direct power and flux control system

2.1. Flux Control Principles

Flux linkage is very important in IMs. Constant flux can provide enough electromagnetic torque and avoid magnetizing current saturation in the iron core of the IM. Therefore in direct torque and flux control, as well as in the proposed direct power and flux controls in the subsequent chapters, the flux is maintained constant [25].

In the stator stationary reference frame, the frame rotation speed is zero and the rotor voltage is zero as well (for squirrel-cage IMs), thus:

$$\vec{V}_s = R_s \vec{i}_s + \frac{d\vec{\lambda}_s}{dt} \quad (1)$$

$$\vec{0} = R_r \vec{i}_r + \frac{d\vec{\lambda}_r}{dt} - j\omega_r \vec{\lambda}_r \quad (2)$$

If we neglect the small voltage drop across the stator resistance, we have

$$\vec{V}_s \cong \frac{d\vec{\lambda}_s}{dt} \quad (3)$$

Integrating (3) and writing it in a discrete form, we obtain

$$\vec{\lambda}_s(t_{n+1}) = \vec{\lambda}_s(t_n) + \vec{V}_s \Delta t \quad (4)$$

That is,

$$\Delta \vec{\lambda}_s \cong \vec{V}_s \Delta t \quad (5)$$

Where $\Delta t = t_{n+1} - t_n$ equals the switching interval.

Therefore, within a switching interval Δt , the increase of stator flux is proportional to the stator voltage space vector. This is the principle of direct flux control in DPC.

2.2. Power Control Principles

From the power flow charts in induction motor, it is evident that real output power is the part that produces the torque, and is what the user of the system is mostly interested in.

The output real power is given by

$$P_{out} = T_e \omega_m = T_e \frac{\omega_r}{p} \quad (6)$$

And

$$\begin{aligned} T_e &= \frac{2}{3} p \text{Im}(\vec{i}_s \vec{\lambda}_s^*) = \frac{2}{3} p \text{Im}\left(\frac{L_r \vec{\lambda}_s - L_m \vec{\lambda}_r}{L_s L_r - L_m^2} \vec{\lambda}_s^*\right) \\ &= -\frac{2}{3} p \frac{L_m}{L_\sigma^2} \text{Im}(\vec{\lambda}_r \vec{\lambda}_s^*) = \frac{2}{3} p \frac{L_m}{L_\sigma^2} \text{Im}(\vec{\lambda}_s \vec{\lambda}_r^*) \\ &= \frac{2}{3} p \frac{L_m}{L_\sigma^2} \lambda_s \lambda_r \sin(\theta_s - \theta_r) \end{aligned} \quad (7)$$

Substituting the torque in (17) with (18), the output power becomes

$$\begin{aligned} P_{out} &= \frac{2}{3} \omega_r \frac{L_m}{L_\sigma^2} \text{Im}(\vec{\lambda}_s \vec{\lambda}_r^*) \\ &= \frac{2}{3} \frac{L_m}{L_\sigma^2} \omega_r \lambda_s \lambda_r \sin(\theta_s - \theta_r) \end{aligned} \quad (8)$$

Since the magnitude of the stator flux is kept constant and the rotor flux does not change much due to its inertia, the rotor speed and angle can be considered constant too. The formula above shows that the change of output power depends only on the change of stator flux angle. The stator voltage vector that can increase the stator angle needs to be raised in order to increase the output power.

The real output power equation obtained above is only valid for explanation of the principles of power control. However, it is not appropriate for the purpose of estimating the actual power in simulations.

2.3. Output Power Reference

The output power reference is the command value, or set point, for the power control. In a closed-loop speed control system, the reference of the power controller is obtained from the output of the PI-type speed controller (see Figure 2). The speed error is defined as the difference of the reference speed and the estimated actual speed

$$\Delta \omega_m = \omega_m^* - \omega_m \quad (9)$$

Where ω_m^* is the reference speed (the asterisk denotes a reference value). Then, the reference torque can be obtained through a conventional PI controller as

$$T_e^* = K_p (\Delta \omega_m) + K_i \int (\Delta \omega_m) dt \quad (10)$$

The continuous standard form above can also be expressed in a discrete incremental PI control form, which is more suitable for the digital implementation.

$$T_e^*(t_{n+1}) = T_e^*(t_n) + K_p[\Delta\omega_m(t_n) - \Delta\omega_m(t_{n-1})] + K_i\Delta T\Delta\omega_m(t_n) \tag{11}$$

The subscript (n) denotes the current sampling instant, (n-1) is the last instant, and (n+1) is the next one. The proportional gain is denoted by K_p , K_i is the integral gain, which Equals K_p divided by the integral time constant T_i , and ΔT is the sampling time interval between the n and (n+1) sampling instants. The output power reference according to (17) is therefore expressed as the process of obtaining the output power reference from the speed reference is illustrated in Figure 3.

For simulations, the actual motor speed ω_m can be obtained as

$$\omega_m = \frac{1}{J} \int (T_e - T_{ld}) dt \tag{12}$$

In practice the speed is either measured directly or estimated from the current and voltage signals. The magnitude of the stator flux is kept constant in the simulation, thus the flux reference λ_s^* is a constant. The error of the stator flux is

$$\Delta\lambda_s = \lambda_s^* - \lambda_s \tag{13}$$

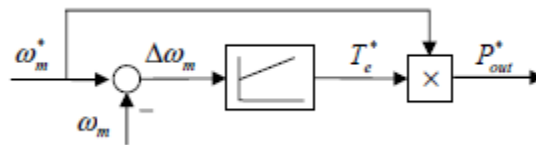

Figure 2. Diagram of output power reference obtained from speed loop

2.4. Power and Flux Hysteresis Controllers

Both the output power and the stator flux controllers are of hysteresis type. Depending on the control error, the output of the controller is set to two or three discrete values. The power controller has a three level output [26-27]. The values are 1, 0 and -1, representing an increase, no change, and a decrease of the controlled variable, respectively. The number of flux controller output levels is two, with 1 and 0 meaning an increase and decrease commands, respectively. Figure 3 illustrates characteristics of these two controllers.

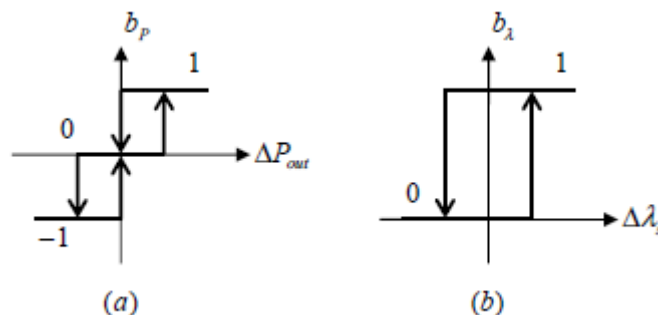

Figure 3. Characteristics of the hysteresis controllers: (a) power controller, (b) flux controller

2.5. Switching Table

The task of the state selector in the direct power control is to combine the outputs of the power controller and flux controller to select the values of the switching variables a, b, and c. These variables describe the required voltage vectors of the inverter.

To make it easier to implement, the combination of the two controller outputs can be expressed as follows:

$$b = 3b_\lambda + b_p + 2 \tag{14}$$

In the above equation, the variable $b = 1, 2, 3, 4, 5, 6$, while $b_\lambda = (0, 1)$ and $b_p = (-1, 0, 1)$. Alternatively, (25) can also be represented by Table 1.

Table 1. Combination of the power and flux controller outputs

$b_p = -1$	$b_p = 0$	$b_p = 1$
1	2	3
4	5	6

A whole stator flux cycle of 360° is divided equally into 6 sectors, each one spanning 60° . Combining with the sector numbers from 1 through 6, produces the lookup Table 2 for the state selection. The concept of state selection is illustrated in Figure 4.

Table 2. State selection loop-up table

	b=1	b=2	b=3	b=4	b=5	b=6
Sector 1	1	0	2	5	7	6
Sector 2	5	7	6	4	0	2
Sector 3	4	0	1	6	7	3
Sector 4	6	7	5	2	0	1
Sector 5	2	0	4	3	7	5
Sector 6	3	7	6	1	0	4

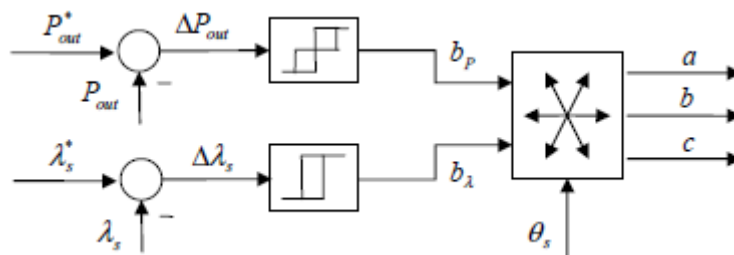

Figure 4. Block diagram of the inverter state selection

Note that the stator flux angle θ_s must be converted to a sector number of 1 through 6 for the use of Table 2 for state selection.

2.6. Estimation of Stator Flux and Output Power

The estimation of flux is implemented by integration of (1):

$$\vec{\lambda}_s = \int (\vec{v}_s - \vec{i}_s R_s) dt \tag{15}$$

These estimated values are the feedbacks for the output power and stator flux controls shown in Figure 5.

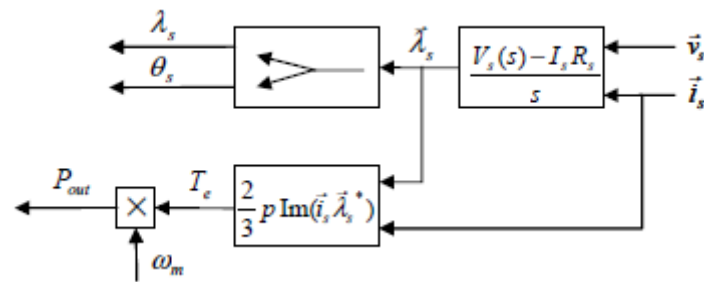

Figure 5. Estimation of actual output power and stator flux linkage

3. Fuzzy Logic Control

3.1. Fuzzy Control

The design of a Fuzzy Logic Controller requires the choice of Membership Functions. The membership functions should be chosen such that they cover the whole universe of discourse. It should be taken care that the membership functions overlap each other. This is done in order to avoid any kind of discontinuity with respect to the minor changes in the inputs. To achieve finer control, the membership functions near the zero regions should be made narrow. Wider membership functions away from the zero region provides faster response to the system. Hence, the membership functions should be adjusted accordingly. After the appropriate membership functions are chosen, a rule base should be created. It consists of a number of Fuzzy If-Then rules that completely define the behaviour of the system. These rules very much resemble the human thought process, thereby providing artificial intelligence to the system [28].

The general fuzzy control structure includes three parts: (1) Fuzzification. The fuzzification process normalizes the input variables and expresses the inputs as suitable linguistic fuzzy sets. (2) Evaluation of control rules. The fuzzy logic is utilized to map the input set to an output set. The rules are stored as one lookup table. (3) Defuzzification. The fuzzy outputs are converted to crisp outputs. The conventional fuzzy system structure is displayed in Figure 6.

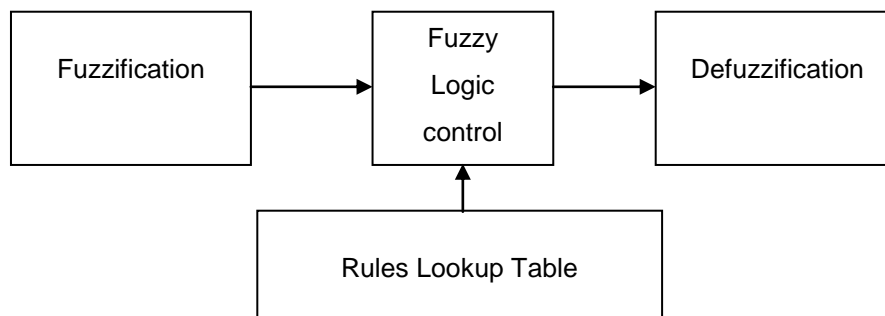

Figure 6. Fuzzy logic control structure

After SOM network, the input parameters have been mapped as 5×5 sets, so it is no need of the fuzzification, and the next step is to apply the fuzzy logic to each input sets. Designers should manually analysis each set and estimate the corresponding motor running status, such as the motor startup or overshoot, light or heavy load, and the control rule table should be listed in according with these statuses. For example, if the average speed error of one cluster is 0.15pu, and the average change of speed error is 0.1pu/s, so this means that the motor is in accelerating status, the regulation factor should be greater. Each cluster of the SOM output sets should be analyzed like this step and marked as logic variables Z, PVS, PS, PM, PB, NVS, NS, NM, NB to represent the control factor types.

The defuzzification maps the fuzzy system output logic variables to control factors, and the factors could be utilized to adjust the speed estimation and regulation factors. The figure of the membership function that reflects the logic sets and the control factors is depicted in Figure 7.

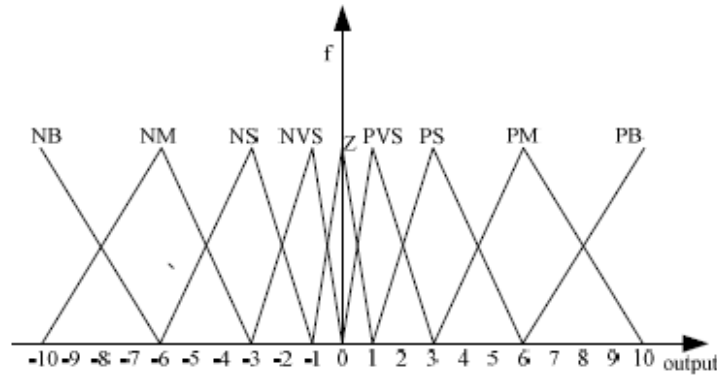

Figure 7. Membership function of the defuzzification

3.2. Induction Motor Fuzzy Logic Control

The direct power control structure is displayed in Figure 8. The fuzzy logic controller generates the output logic through the lookup rule table, and determines the final output according to the membership function as depicted in Figure 7. The fuzzy control system output factors should be employed to adjust the close loop controller, such as the current controller and the parameters convergence of the observer adaptive process.

Table 3. Fuzzy Logic Rule

X	Y				
	1	2	3	4	5
1	NB	NM	NS	NVS	Z
2	NM	NS	NVS	Z	PVS
3	NS	NVS	Z	PVS	PS
4	NVS	Z	PVS	PS	PM
5	Z	PVS	PS	PM	PB

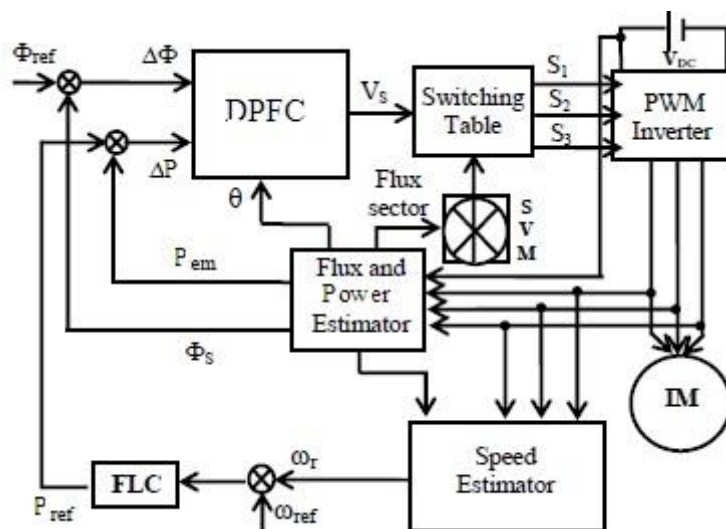

Figure 8. Schematic Direct Power Control of Induction Motor Drive using Fuzzy Logic

4. Simulation Results

The proposed method is simulated by Matlab/Simulation platform. The control system is shown in Figure 8. Figure 9 shows stator and rotor flux trajectory using Fuzzy controller and Figure 10 shows stator current using Fuzzy controller. Speed-torque curve is shown in Figure 11. Figure 12 and 13 show power tracking and speed tracking using DPC strategy with Fuzzy controller, respectively. These results show that the designed estimator properly worked in Matlab/Simulink. Simulation results also shows that the proposed method has a good performance of speed estimator.

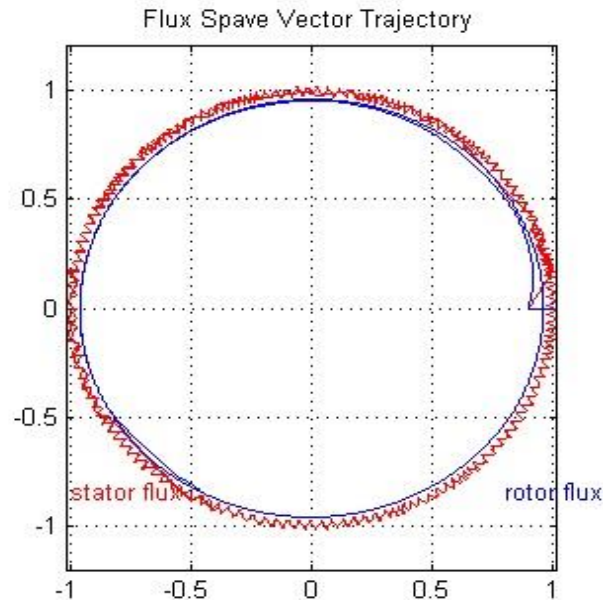

Figure 9. Stator and Rotor flux trajectory using DPC Strategy with Fuzzy controller

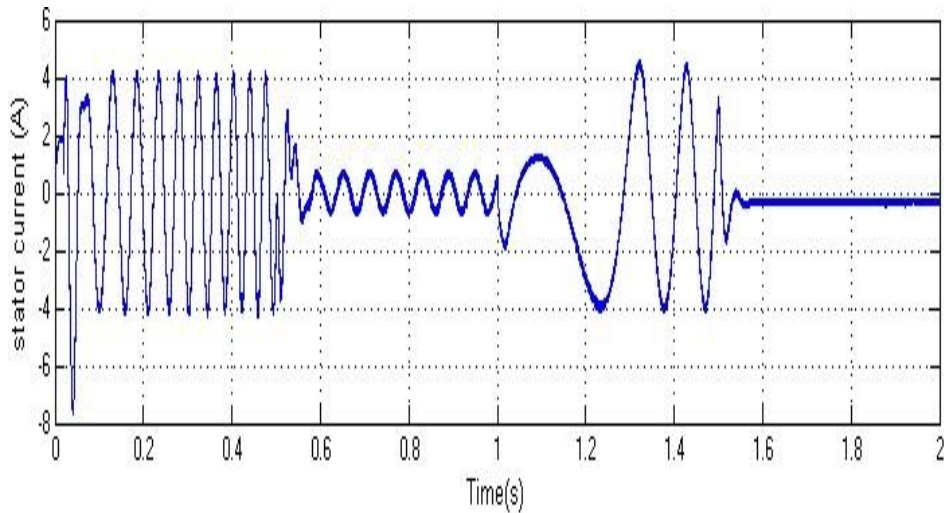

Figure 10. Stator current using DPC Strategy with Fuzzy controller

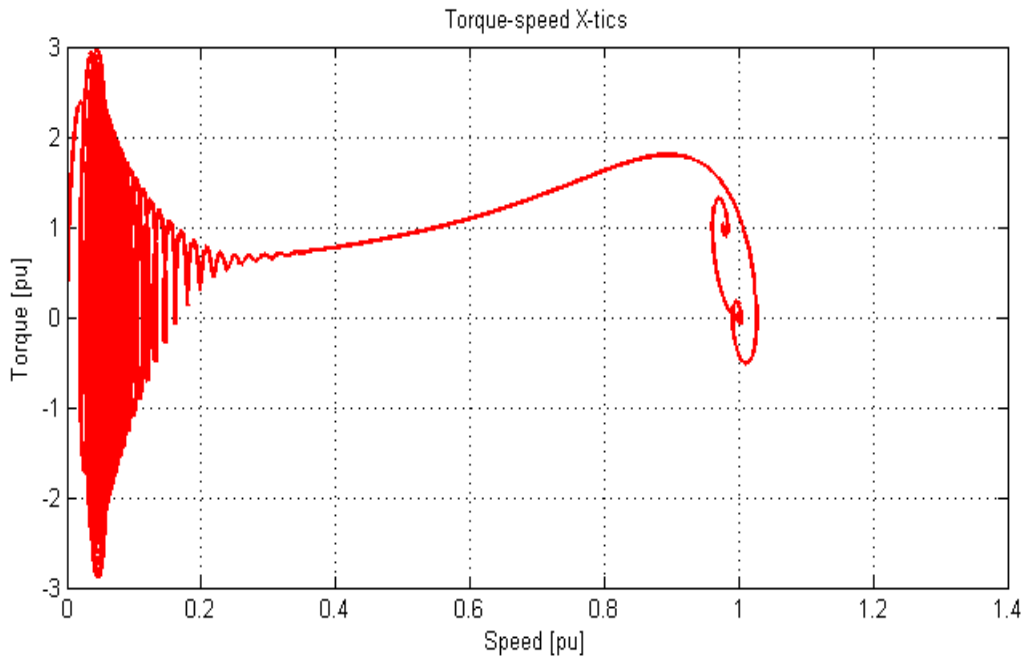

Figure 11. Speed-torque curve using DPC Strategy with Fuzzy controller

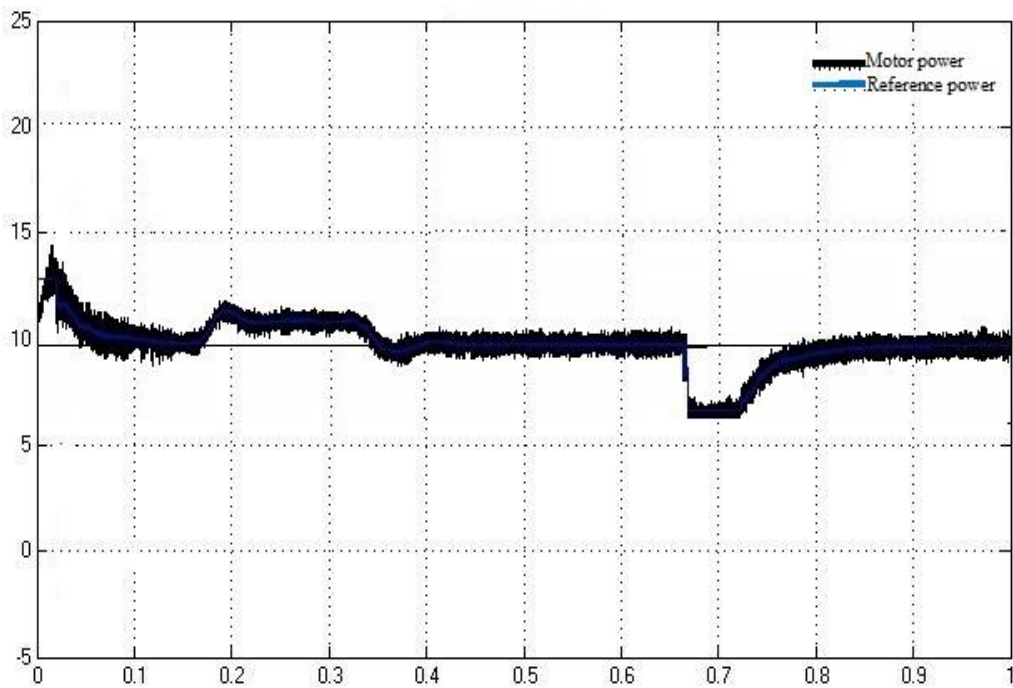

Figure 12. Power Tracking using DPC Strategy with Fuzzy controller

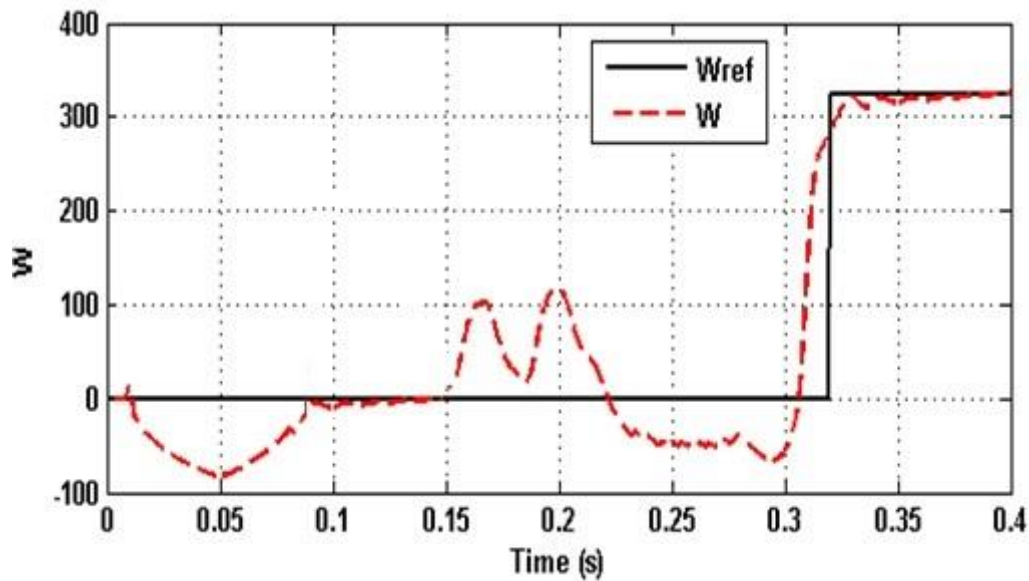

Figure 13. Speed Tracking using DPC Strategy with Fuzzy controller

5. Conclusion

The direct power control of induction motor with fuzzy logic controller is investigated in this paper. A novel speed drive for induction motor of moderate performance and low computational effort has been designed and described. An important contribution of the work is the design of a fuzzy system. The simulation shows that the fuzzy logic speed can identify and track the motor speed accurately during the whole operating region.

References

- [1] PC Krause O Waszynozuk, SD Sudhoff. Analysis of Electric Machinery and Drive Systems. IEEE Press, Second Edition. 2002.
- [2] I Boldea, SA Nasar. "Electric Drives". Taylor & Francis. 2006.
- [3] P Vas. "The control of ac machines". Oxford Univ. 1990.
- [4] AM Trzynadlowski. "Control of Induction Motors". Academic press. 2001.
- [5] GS Buja, MP Kazmierkowski. "Direct torque control of PWM inverter-fed AC motors - a survey". *IEEE Trans. on Industrial Electronics*. 2004; 51(4): 744-757.
- [6] G Escobar, AM Stankovic, JM Carrasco, E Galvan, R Ortega. "Analysis and design of direct power control (DPC) for a three-phase synchronous rectifier via output regulation subspaces". *IEEE Trans. on Power Electronics*. 2003; 18(3).
- [7] S Vazquez, JA Sanchez, JM Carrasco, JI Leon, E Galvan. "A Model-Based Direct Power Control for Three-Phase Power Converters". *IEEE Trans. on Industrial Electronics*. 2008; 55(4): 1647-1657.
- [8] Z Dawei, X Lie, BW Williams. "Improved Direct Power Control of Grid-Connected DC/AC Converters". *IEEE Trans. on Power Electronics*. 2009; 24(5): 1280-1292.
- [9] X Lie, P Cartwright. "Direct active and reactive power control of DFIG for wind energy generation". *IEEE Trans. on Energy Conversion*. 2006; 21(3): 750-758.
- [10] Z Dawei, X Lie. "Direct Power Control of DFIG with Constant Switching Frequency and Improved Transient Performance". *IEEE Trans. on Energy Conversion*. 2007; 22(1): 110-118.
- [11] Y Errami, M Benchagra, M Hilal, M Maaroufi, M Ouassaid. "Control strategy for PMSG wind farm based on MPPT and direct power control". *International Conference on Multimedia Computing and Systems (ICMCS)*. 2012: 1125-1130.
- [12] A Harrouz, A Benatiallah, O Harrouz. "Direct power control of a PMSG dedicated to standalone wind energy systems". *International Conference and Exhibition on Ecological Vehicles and Renewable Energies (EVER)*. 2013: 1-5.
- [13] P Vas. "Vector and Direct Torque Control". Oxford University Press, Newyork. 1998.
- [14] K Sedhuran, S Himavathi, A Muthuramalingam. "Performances Comparison of Neural Architectures for On-Line Speed Estimation in IM Drives". *World Academy of Science, Engineering and Technology*. 2011; 60: 1318-1325.

- [15] S Meziane, R Benalla. "MRAS based speed control of sensorless Induction motor Drives". *ICGST-ACSE Jurnal*. 2007; 7(1): 43-500.
- [16] E Levi, M Wang. "Impact of parameter variations on speed estimation in rotor flux oriented induction machines". *IEEE Proc. Of Power Electronics and Variable Speed Drives*. 1998; 456: 305-310.
- [17] ME Elbulk, L Tong, I Husain. "Neural Network based Model Reference Adaptive systems for high performance motor drives and motion controls". *IEEE Trans. Ind. Applcat*. 2002; 38.
- [18] HB Zhou, B Long, BG Cao. "Vector Control System of Induction Motor Based on Fuzzy Control Method". *PEITS*. 2008: 136-139,
- [19] J Catala, L Romeral, E Aldabas, A Arias, MG Jayne. "Novel Speed Fuzzy Control for Induction Motors". *PEDS*. 2003; 1: 205-209.
- [20] BK Bose, NR Patel. "A stator flux oriented vector controlled induction motor drive with neuro-fuzzy based performance enhancement". in Proc. 32nd IEEE-IAS Annu. Meeting, New Orleans, LA. 1997; 1: 393-400.
- [21] L Romeral, J Llaquet, E Aldabas, A Arias. "A simple fuzzy adaptive speed controller". in Proc. 35th IEEE-IAS Annu. Meeting, Rome, Italy. 2000: 1249-1256.
- [22] E Girovsky, J Timko. "Shaft Sensor-less FOC Control of an Induction Motor Using Fuzzy logic Estimators". *Acta Polytechnica Hungarica*. 2012; 9(4).
- [23] DP Kothari, IJ Nagrath. "*Electric Machines*". Tata McGraw – Hill Education Private Limited, ISBN-13: 978-0-07-058377-1, ISBN-10: 0-07-058377-3. 2004; 9.
- [24] G Escobar, AM Stankovic, JM Carrasco, E Calvan, R Orteg. "Analysis and design of direct power control (DPC) for a three-phase synchronous rectifier via output regulation subspaces". *IEEE Trans. on power Electronics*. 2003; 18(3).
- [25] NRN Idris, AHM Yatim. "Direct Torque Control of Induction Machines with Constant Switching Frequency and reduced Torque ripple". *IEEE Trans. Ind. Electron*. 2004; 51.
- [26] G Escobar, AM Stankovic, JM Carrasco, E Calvan, R Orteg. "Analysis and design of direct power control (DPC) for a three-phase synchronous rectifier via output regulation subspaces". *IEEE Trans. on power Electronics*. 2003; 18(3).
- [27] ung-Hoe Huh, Kyo-Beum Lee, Dong-Won Kim, Ick Choy, and Gwi-Tae Park. "Speed Control System Using a Neural Network". *International Journal of Control, Automation, and Systems*. 2005; 3(4): 612-619.
- [28] M Wahba. "MIMO Indirect Adaptive Fuzzy Control of Induction Motors". *ISIE 2007*. 2007: 124-129.