

Invention into the AC Voltage Regulator with V/F Technique for Induction Motor Starting Applications

Mahesh Kollipara¹, V N Srinivasa Rao Kolluru²

¹ PE&D, KL University, Vaddeswaram, Guntur, Andhra Pradesh, India

² Department of EEE, KL University, Vaddeswaram, Guntur, Andhra Pradesh, India

e-mail: mahesh.kollipara@gmail.com

Abstract

Modern electrical motors are available in many different forms with different mounting arrangements. To ensure a long life for the motor it is important to select it with correct degree of protection when operating under heavy duty conditions in a severe environment. Smooth starting is also one of major considerations to get long life and optimum efficiency. The conventional method to start an asynchronous motor with a soft starter is by reducing the voltage of the motor by varying the voltage "off time". The "off time" could for example be controlled to achieve a desired maximum current level or a constant driving torque. Even if the voltage is reduced the fundamental frequency of the voltage is equal to the supply voltage frequency. That gives a large difference between angular speed of supply voltage and angular speed of the rotor during start. Due to the large difference in angular speed the motor flux will be low and thereby also the ability to produce torque. Instead of using the conventional control method with a reduced voltage it is possible to use a method with controlled flux similar to frequency inverters for soft-starters. As the soft-starter does not have the intermediate DC energy storage the applied voltage vector has to be directly modulated from the mains supply.

Keywords: induction motor, soft starter, V/f control

1. Introduction

The conventional method to start an asynchronous motor with a soft starter is by reducing the voltage supplied to the motor by varying the voltage "off time" could for example be controlled to achieve a desired maximum current level or a constant driving torque [1], [3-4]. The following figure 1 shows a simplified (resistive load) one phase example of how a reduced voltage may be shaped. In past few years the soft starters for an induction motor become an attractive and commercially expanding technology. So many methods are developed to start induction motor (Direct On Line, Star/Delta, primary resistance and Rotor resistance starter etc) [4]. Main draw backs of the existed system are high inrush currents, voltage dip, frequency dip, small acceleration time, high starting torque and high cost [7-10]. Due to these drawbacks the life time of the motor will reduce. All these drawbacks are eliminated by using softstarter with limited conditions; softstarters are not useful for high initial load torque applications like saw applications, belt drive applications and crushers etc.

This new technique will push all existed techniques. By using this method we can control starting current and starting torque by v/f technique. So that we can easily eliminate all problems of high starting current (inrush current), high torque pulsations, stress on motor bearings and thereby increasing the life of the motor by energy saving [6].

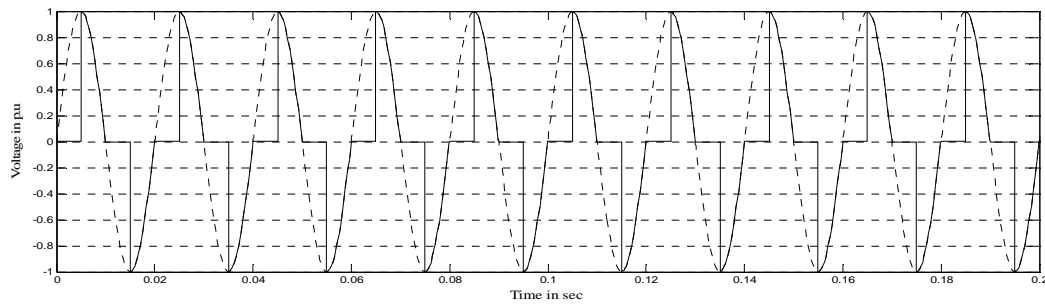

Figure 1. Varying voltage off time

This research mainly focused on soft start and soft stop of an induction motor. As we know that torque of an induction motor is directly proportional to square of the current and current is in turn proportional to the voltage there by torque proportional to square of the voltage. Starting currents are depends on the voltage applied to the motor. As we reduce the voltage at the time of starting, the starting currents are also reduced.

In this paper we use power electronic switches to regulate output voltage and currents. As there is no need of commutation (i.e natural commutation is sufficient) thyristors are used. Total of six thyristor switches are used, two as back to back in each phase. As firing angle (alpha) varies, the voltage applied to the motor also varies. For example, at zero firing angle the output voltage is same as that of input voltage ($V_o=V_s$), At 180° of firing angle the output voltage is zero ($V_o=0$). So as we change firing angle linearly, voltage applied to the motor also varies linearly. This can be done by applying ramp voltage control. It results in linear change of voltage, which leads to reduction in current and motor torque. The expression for the rms value of the output voltage per phase for a balanced load is as follows. [3]

$$E_o = \sqrt{\left[\frac{1}{2\pi} \int_0^{2\pi} (e_{ph}^2) d\theta \right]}$$

Duration of the ramp will be decided by rating of the motor. For example for lower rating motors (say 4Kw) duration of the ramp is lower (say to 2 to 4 sec), for higher rating motors duration will increase (22Kw requires 14 to 16 sec).

2. Operation

At each stage of the operation atleast two thyristors should conduct at a time. One for source to load flow and one for return path (i.e load to source). No two thyristor's in same leg should conduct in same time.

Start mode:

The voltage applied to the motor determines the motor starting torque. This starting voltage must reach the required torque to start the motor. The length of the ramp period decides the start time of the motor. It leads the motor's acceleration torque, which uses to drive the load during acceleration time. Ensure that the acceleration time should be long enough for the motor to reach its nominal speed to create smooth acceleration. The graph corresponding to ramp voltage versus time is plotted in figure 2.

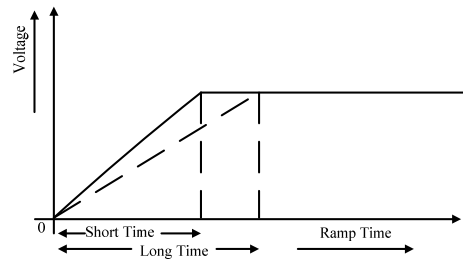

Figure 2. Ramp Voltage at start with time

The motor current that flows during the ramp up process can be actively limited by means of soft starter. The current limiting function takes priority over the voltage ramp function (the current limiting value is set to the current required during starting as a factor of the motor current).

Softstarter is equipped with an integrated ramp up detection function. If it detects a motor start up, the motor voltage is immediately increased 100 percent of the mains voltage. The internal bypass contacts close and the thyristors are bridged.

Stop mode:

However the stop process of the motor is same as the start process. In this soft stop mode, the load is decelerated to get natural stop. The 'ramp down time' potentiometer on the softstarter allows you to specify how long power should still be supplied to the motor after the "ON" command is removed. The torque generated in the motor is reduced by means of a voltage ramp function within this ramp down time and the application stops smoothly. The following figure 3 represents the different stop times for motor load.

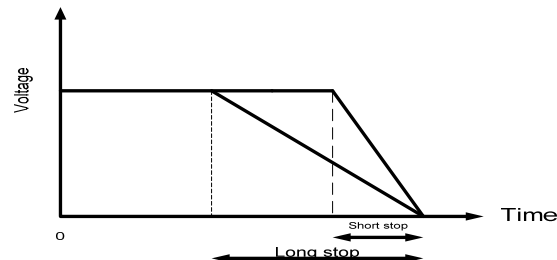

Figure 3. Ramp Voltage at start with time

In pump applications, water hammer effect can occur when motor stops with DOL or star/delta starter. Due to sudden change in water flow causes water hammer which leads to pressure fluctuations on the pump. It creates noise and mechanical impacts on the pipelines as well as on any valves installed there. This effect can be minimised by softstarter rather than DOL and star/delta.

Here the results of conventional softstarter with smooth start and smooth stop as shown in figure 4. In both the cases the input current is limited. Problem of taking high input current at starting is eliminated. At the same time due to smooth stop problem of pressure fluctuations in pump applications can be eliminated.

The main drawback for this design is, it is not suitable for high starting torque applications like saw applications and belt drive applications. To overcome this problem, the new technique is proposed in this paper. This new technique also uses same number of switches to change both voltage and frequency with phase angle control technique. Making v/f ratio constant starting torque of the motor should be high.

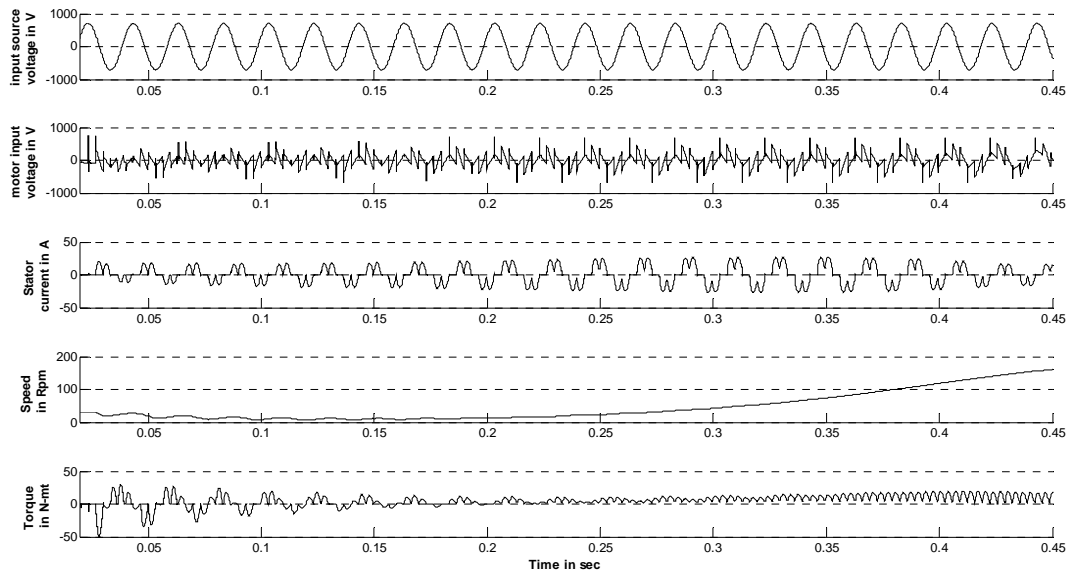

Figure 4. Motor parameters with simple 4KW motor with conventional softstarter

3. Proposed Technique

In this paper, the same technique (phase angle control) as shown in figure 5 is used to vary the voltage and as well as frequency. When voltage is reduced to half or one fourth at the time of starting, it creates lower flux in motor causing high currents at starting. Thereby large unregulated currents will produced at starting. To avoid this problem, frequency should decrease in such a manner that v/f should be constant. Thereby starting currents will remains lower but starting torque will increase due to constant v/f ratio.

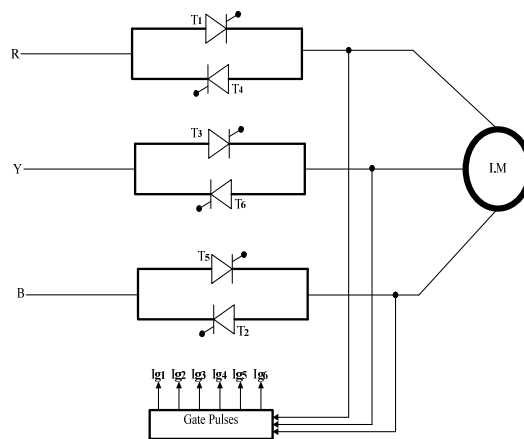

Figure 5. Schematic Diagram

Here pulses given to power circuit are similar to the phase angle control in conventional soft starters. For frequency conversion operation the subsequent pulses should miss from firing there by frequency can reduce to half.

This method is used for all lower frequencies less than 50Hz. We can use this technique for any of the frequency (f/2, f/3, f/4.....f/49) but ensure that the voltage at the terminals of the motor should be in same ratio. Otherwise a large value of disturbances will occur due to lower frequencies.

In this paper the results are for one fourth of the frequency and half of the frequency, since most of the industries operates at this frequencies. Cyclo converters are used for starting and running applications like a drive system, where as the cyclo soft starter is used for starting applications only.

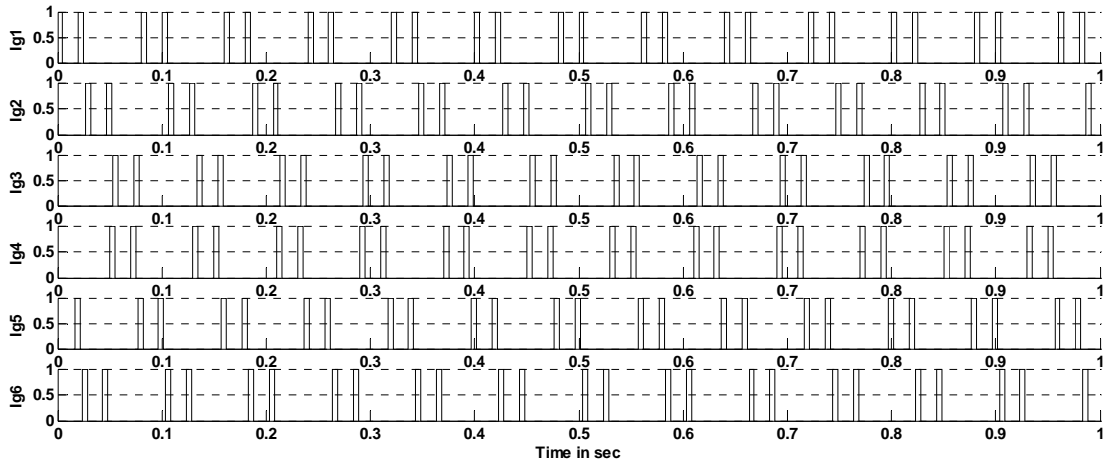

Figure 6. Triggering pulses for f/4 operation

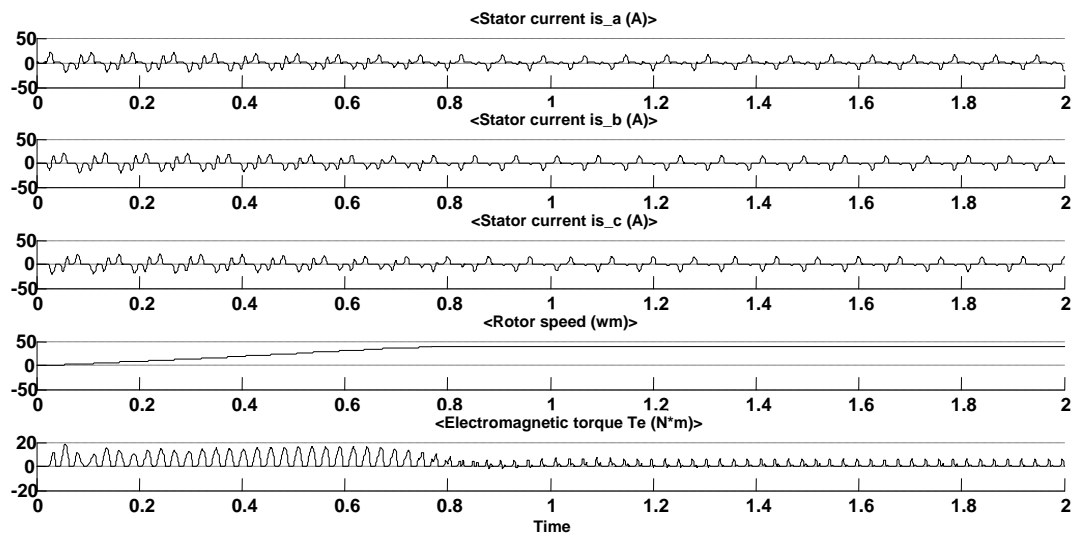

Figure 7. Motor parameters for f/4 and v/4 operation

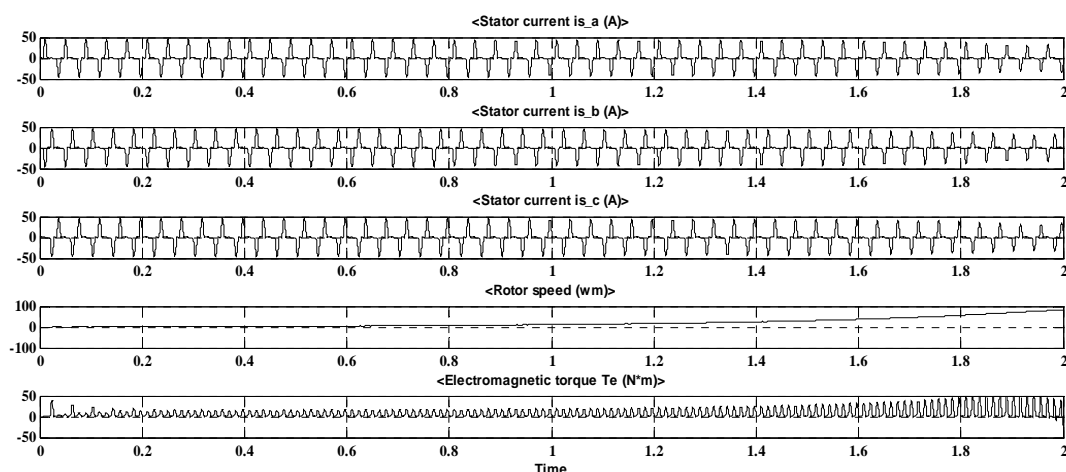

Figure 8. Motor parameters for $f/2$ and $v/2$ operation

These results are compared with normal conventional soft starter; the torque characteristics of the induction motor are improved. Which means the starting torque of the motor is increased. The problem of low starting torque in conventional method is eliminated.

4. Conclusion

The method described above gives control of the motor (e.g. torque and speed). It will also significantly reduce the starting/braking current and at the same time increase starting/braking torque. By these two major benefits with the new control method compared to conventional softstarter control methods; it may be possible to use cyclo soft starters in applications previously not suited for conventional soft starter. For example applications with high initial load torque like crushers etc. Applications with need for fast and controlled braking like saw applications or high inertia loads, etc. Applications benefitting from defined start time etc.

References

- [1] Nied A, De Oliverira J, De Farias Campos R, Dias RP and De Souza Marques LC. "Soft starting of Induction motor with torque control". *IEEE Trans. Ind. Applicat Mag.* 2010; 46: 1002-1010.
- [2] Xiaodong Liang, Schlumberger. Edmonton and Laughy R, Liu J. "Investigation of Induction Motors Starting and Operation with Variable Frequency Drives". *IEEE Trans. Elect and comp engg.* 2007: 556-561.
- [3] Zhao Kaigi, Xu Dianguo and Wang Yi. "New strategy to improve electromagnetic torque at starting in thyristor controlled induction motor". *IEEE Trans. Indus electronics.* 3: 2555-2560.
- [4] Herman KJ. "A soft starter AC voltage regulator". *IEEE Trans. Circuits and systems.* 1991; 1: 184-185.
- [5] Al-Ali AR, El-Amin I, Kassaa M and Al-Saif. "A Programmable AC voltage regulator". *IEEE Trans. indust automation and contro.* 1995: 525-529.
- [6] F Blaabjerg, JK Pedersen, S Rise, HH Hansen and AM Trzynadlowski. "Can soft-starters help save energy". *IEEE trans. Ind. Applicat. Mag.* 1997; 3: 56-66.
- [7] Zenginobuz G, Cadirci I, Ermis M and Barlak C. "Soft starting of induction motor at constant current with minimized starting torque pulsations". *IEEE trans on Indust application.* 2001; 37: 1334-1347.
- [8] Solveson MG and Mirafzal B. "Soft started induction motor modelling and heating issues for different starting profiles using a flux linkage abc frame of reference". *IEEE Tran.Indust. Application.* 2004; 1.
- [9] FM Bruce, RJ Graefe, A Lutz and MD Panlener. "Reduced voltage starting of squirrel cage induction motors". *IEEE trans. Ind applications.* 1984; 1A-20: 46-55.
- [10] PJ Colleran and WE Rogers. "Controlled starting of ac induction motors". *IEEE Trans. Ind.Applicant.* 1983; IA-19: 1014-1018.
- [11] A Text book of "Modern Electric Drives" by Bimal K Bose.