



Kim, B. C., Potter, K. D., & Weaver, P. M. (2012). Multi-tow shearing mechanism for high-speed manufacturing of variable angle tow composites. In 15th European Conference on Composite Materials (ECCM15).

[Link to publication record in Explore Bristol Research](#)  
PDF-document

## University of Bristol - Explore Bristol Research

### General rights

This document is made available in accordance with publisher policies. Please cite only the published version using the reference above. Full terms of use are available:  
<http://www.bristol.ac.uk/pure/about/ebr-terms.html>

### Take down policy

Explore Bristol Research is a digital archive and the intention is that deposited content should not be removed. However, if you believe that this version of the work breaches copyright law please contact [open-access@bristol.ac.uk](mailto:open-access@bristol.ac.uk) and include the following information in your message:

- Your contact details
- Bibliographic details for the item, including a URL
- An outline of the nature of the complaint

On receipt of your message the Open Access Team will immediately investigate your claim, make an initial judgement of the validity of the claim and, where appropriate, withdraw the item in question from public view.

# MULTI-TOW SHEARING MECHANISM FOR HIGH-SPEED MANUFACTURING OF VARIABLE ANGLE TOW COMPOSITES

B.C. Kim<sup>1\*</sup>, K. Potter<sup>1</sup>, P.M. Weaver<sup>1</sup>

<sup>1</sup>ACCIS (Advanced Composites Centre for Innovation and Science), University of Bristol, Queen's Building, University Walk, Bristol BS8 1TR, UK

\*aebck@bristol.ac.uk

**Keywords:** automated fibre placement (AFP), variable angle tow (VAT), continuous tow shearing (CTS), non-crimped fabric (NCF)

## Abstract

*An innovative tow steering technique using shear deformation characteristics of the dry tow material has been developed to minimize the process-induced defects by changing the most fundamental way of handling tow materials of all conventional AFP techniques, and was named as 'CTS (Continuous Tow Shearing)'. The objective of this research was to improve the productivity of the CTS process by using the stitched unidirectional non-crimped fabric (NCF) with multiple carbon tows rather than a single carbon tow and eliminating the in-situ impregnation process with slow process speed. A prototype of the CTS head module with a wide feed mechanism for the NCF and the resin film was developed and installed on a prepreg cutting machine for process validation.*

## 1 Introduction

### 1.1 Variable Angle Tow (VAT)

Although the concept of tailored fibre orientation was developed several decades ago, the structural efficiency of variable angle tow (VAT) composites with non-linear fibre paths has attracted great attention recently. Tailoring the in-plane stiffness can improve the buckling and post-buckling performance by redistributing loads [1, 2]. Also, stress concentrations around cutouts of the composite plate can be relieved by using fibre-steered laminates [3]. Currently, many researchers are studying VAT composite structures with various geometries such as curved shells with cutouts, cylinders and conical shells. Naturally, specialized manufacturing methods such as AFP (Automated Fibre Placement) and TFP (Tailored Fibre Placement) techniques have become important.

### 1.2 Origin of process-induced defects of the automated fibre placement (AFP)

The current key technology for manufacturing VAT composites is the automated fibre placement (AFP) technique which was developed at several places independently in the early 1980s [4]. Even though the AFP process was not originally developed for steering fibres, it is being used widely for manufacturing VAT composites without modification of the fundamental way of handling tow materials by tuning the robot control scheme precisely. Many current AFP machines provide a capability to steer the tow path within a limited design space wherein the manufacturable radius of curvature of the tow path should be limited to 500 mm or more to prevent the fibre buckling and straightening when the fibre placement head imparts in-plane bending deformation to the tow material [5]. If the radius is too small, the

fibres both inside and outside the curved tow element tend to be buckled and straighten [6], which produces process-induced defects such as fibre wrinkling and resin pockets. Consequently, it decreases the load-carrying capability of the structure. All current AFP machines even including the TFP (Tailored Fibre Placement) embroidery machines produce these process-induced defects [7].

### 1.3 Continuous Tow Shearing

In previous research, a novel fibre placement technique using the shear deformation characteristic of dry tow rather than the in-plane bending deformation has been developed and was named ‘Continuous Tow Shearing (CTS)’ [8]. Fig. 1 shows the differences in the tow deformations that both the conventional AFP and the CTS use for tow placement. All current AFP techniques use in-plane bending deformation of the tow material as shown in Fig. 1 (a), while the CTS technique uses the in-plane shear deformation as shown in Fig. 1 (b) so that it can avoid fibre buckling or straightening.

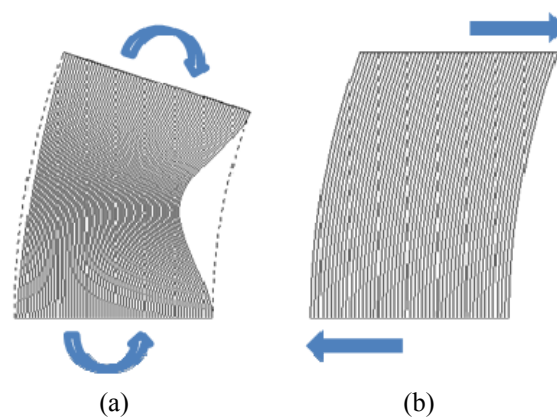

**Figure 1.** Differences in tow deformations: (a) in-plane bending, (b) in-plane shear.

Fig. 2 (a) shows how the CTS head can steer the fibres by shearing the tow material continuously. The tip of the head has a compaction shoe to press one end of the sheared tow for fixing it on the substrate as well as a pinch device to grip and move the other end slightly apart from the substrate. Although both compaction shoe and the pinch device are fixed to the same frame, in-plane shear deformation can be applied to the tow material continuously when the frame moves following the reference tow path because the compaction shoe can slide on the laid tow. This novel manufacturing process can produce a perfectly shifted fibre arrangement as shown in Fig. 2 (b) while minimizing process-induced defects such as fibre wrinkling and resin pocket [8]. As the shear deformation of the tow material accompanies thickness change, the manufactured VAT composite has a thickness variation along the perpendicular direction to the shifting direction as shown in Fig. 2 (b), which is directly related to the shear angle. This smooth thickness distribution is another advantage of the CTS technique because the conventional AFP produces uneven thickness distribution caused by tow drops or overlaps to achieve a perfectly shifted fibre arrangement.

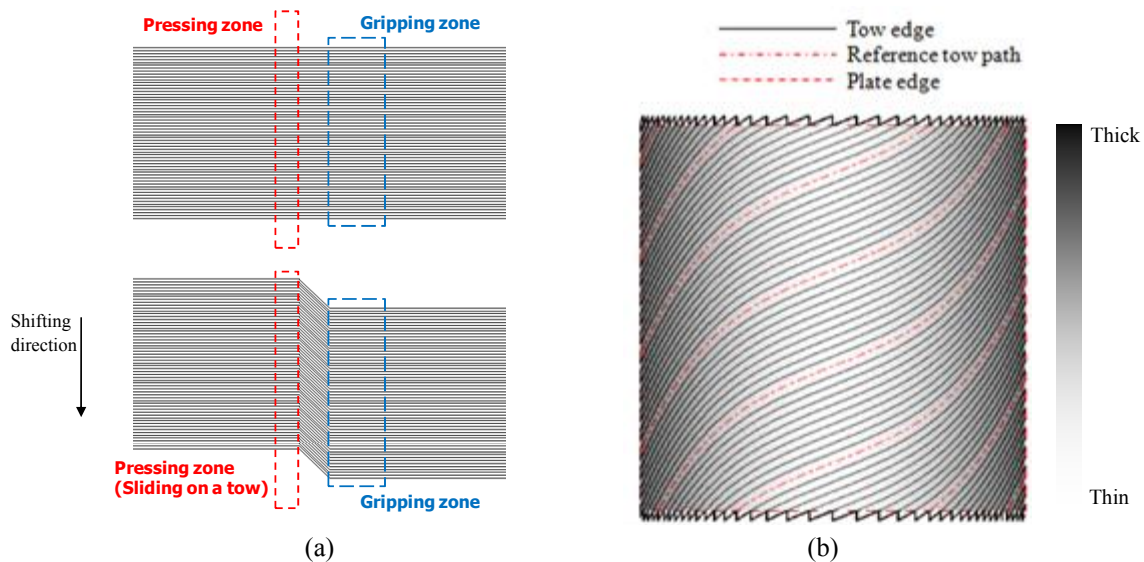

**Figure 2.** CTS head module and tow deformation: (a) tow deformation characteristic (top view), (b) fibre arrangement and thickness distribution following the shifting method.

## 2 Continuous Multi-Tow Shearing (CMTS)

### 2.1 Concept

In order to allow the compaction shoe to slide on the laid tow without causing the out-of-plane fibre splitting or shear breakage between fibres, the dry tow should be impregnated partially to bind fibres. It requires the in-situ impregnation device which is one of the key features of the CTS head module [8]. Impregnating the tow material just before placement can improve the fibre straightness significantly by minimizing tow twisting and bending after impregnation. However, it also reduces overall process speed. Although increasing the impregnation speed by optimizing the process parameters was a solution, another approach was tried in this work.

To remove the impregnation process before the tow laying process, an alternative way to bind the fibres within a tow is needed because the binding force of the sizing material is not strong enough to prevent the out-of-plane fibre splitting which may be caused by the compaction shoe. If the sizing is too heavy, it can reduce the flexibility of the tow material. The unidirectional NCF (Non-Crimp Fabric) material with stitching yarns is a good alternative material. **Fig. 3** shows the cross-sections of the partially impregnated dry tow and the unidirectional NCF. In the case of dry tow, the resin should penetrate the dry tow in the through-thickness direction to hold the interior fibres, which requires slow feed speed to secure enough time for impregnation. On the contrary, for the unidirectional NCF, simple transfer of the resin film to the bottom side can provide enough binding force by fixing the stitching yarn with the resin layer as shown in **Fig. 3 (b)**. Therefore, multiple tows can be laid using the continuous shearing process without the in-situ impregnation process.

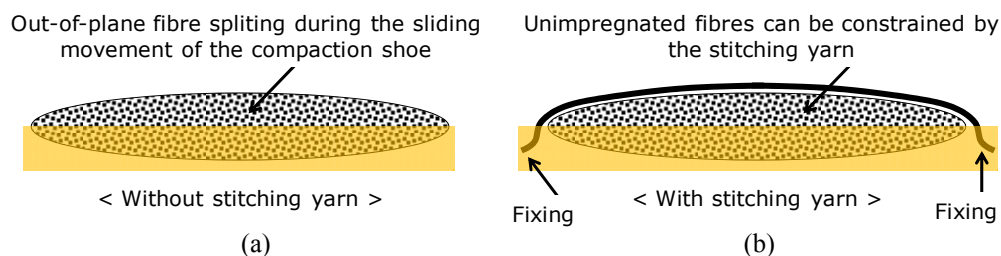

**Figure 3.** Cross-sections of tow materials: (a) dry tow (CTS), (b) unidirectional NCF (CMTS).

In this work, the developed CTS technique was modified to use unidirectional NCF materials, which was named ‘Continuous Multi-Tow Shearing (CMTS).’ Fig. 4 shows the key components of the CMTS head module. The main mechanism is the same with the CTS head module, which has the PTFE compaction shoe and the pinch device comprising the tow guide roller and the gripping shoe. The difference is that a pair of the PTFE compaction roller and the silicone rubber roller is simply used without a heating element instead of the in-situ impregnation device. The unidirectional NCF and the epoxy resin film are supplied from individual sources passing over different guide rollers, and they are combined at the compaction roller assembly. The main feed force comes from taking up the backing paper of the resin film with the rewinding rollers, and the NCF is fed with the resin layer due to its adhesion with the backing paper. When the backing paper turns its direction at the front end of the gripping shoe with a small radius, the resin layer is released from the backing paper and the NCF with transferred resin film on the bottom surface is laid down on the substrate. The compressive force on the laid NCF is supplied by the pneumatic actuator.

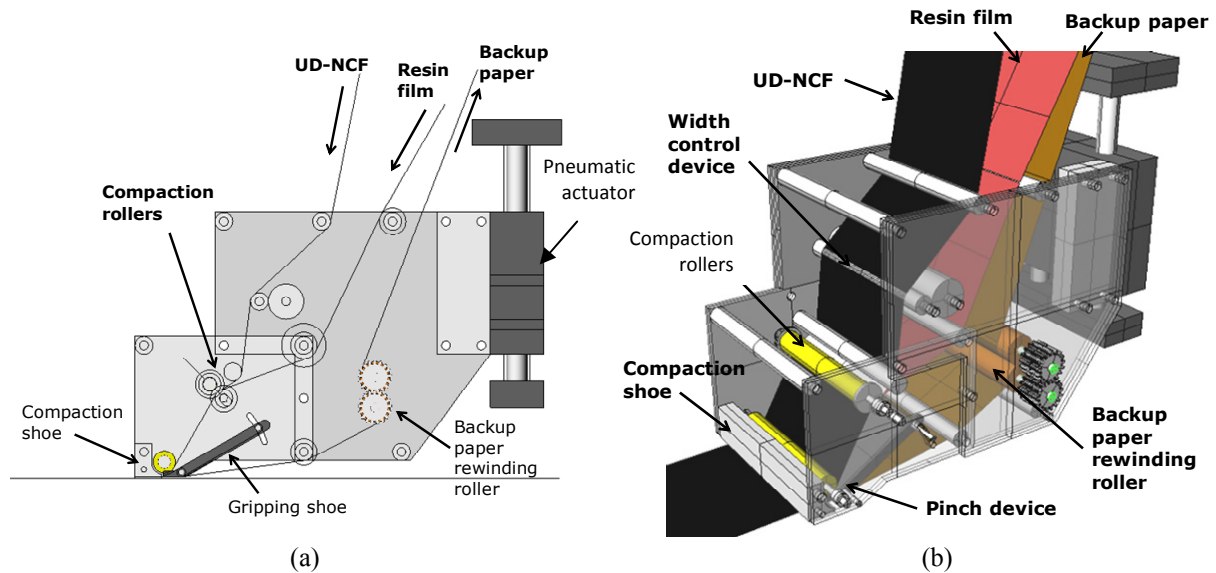

Figure 4. Schematic drawing of the CMTS head module: (a) side view, (b) perspective view.

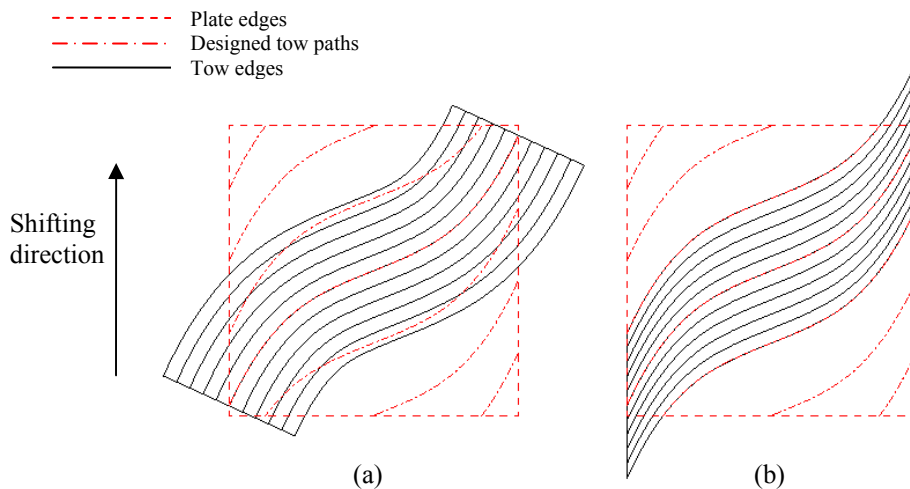

Figure 5. Difference of tow arrangements: (a) conventional AFP, (b) CMTS.

## 2.2 Manufacturing characteristics

The main purpose of CMTS is increasing the productivity by laying many numbers of tows simultaneously. But it is not only using multiple tows but also solving a coupling problem in the manufacturing process.

First of all, it needs to be understood that fibre arrangements of both the conventional AFP and the CMTS are totally different as shown in Fig. 5. Based on the fact that the designed tow paths follow a shifting method rather than a parallel method in most cases, individual tows cannot follow the designed tow path in the conventional AFP process. It implies that the fibre angle needs to be approximated and tow drop or overlap technique is required. On the contrary, the CMTS can lay the tow perfectly following the designed shifting method without any tow drop and overlap, which is a great advantage of the CMTS process.

In terms of productivity, the conventional AFP machine is known to be able to lay a large number (up to 32) of tows of 3.175-12.7 mm width at the same time [6]. However, the conventional AFP technique has a coupling effect between productivity and design flexibility. In most cases, VAT composite structures are designed to have shifted tow paths where every fibre trajectory should simply be shifted from a reference path [7]. Because the conventional AFP head lays multiple tows in parallel, more tow drops or overlaps should be applied as the tow width increases. Furthermore, as it deforms the tow material with in-plane bending deformation, the wider tow array induces the smaller radius of curvature along the inside edge. Beakou and et al. [6] suggested an analytical solution to calculate the critical radius of curvature of the tow which is the minimum radius to prevent fibre buckling as

$$r = \frac{E_L b h}{2\alpha N_{0,cr}} \quad (1)$$

where  $E_L$  is the longitudinal Young's modulus of the tow,  $b$  and  $h$  are the width and thickness of the impregnated tow,  $\alpha$  is the load parameter between 1 and 2 in the in-plane bending mode,  $N_{0,cr}$  is the critical buckling load.

As the width of the tow increases in order to improve the productivity, the critical radius increased proportionally. Thus the design flexibility should be sacrificed. Furthermore, even when 3 mm wide tows are used, the minimum radius is larger than 500 mm [6], which implies that the current AFP technique cannot be used to manufacture a small sized VAT composite structure.

On the contrary, CTS can totally decouple the relationship between productivity and design flexibility as the critical radius depends on the critical shear rate as shown below. The critical shear rate is the shear deformation rate which can guarantee the fibre straightness under the in-plane shear deformation, which is variable with respect to the resin system

$$r = V / \dot{\theta}_{max} \quad (2)$$

where  $V$  and  $\dot{\theta}_{max}$  are the tow laying speed and critical shear rate, respectively.

Experimentally it was shown that the minimum radius could be decreased to 30 mm [8]. Because increasing the width of the tow material does not affect the tow quality, the productivity is directly proportional to the width of the tow material. This is the novelty of the CMTS technique.

### 3 Prototype test

In order to validate the CMTS concept, the prototype head was mounted on the prepreg cutting machine as shown in Fig. 6, which played the role of a x-y moving stage. The unidirectional NCF comprising 40 bundles of 24K tows was laid with the 90 mm wide epoxy resin film (Hexcel 914, USA) in the layup speed of 4 mm/sec. The PTFE guides were used to adjust the width of the NCF material, which was slightly uneven along the fibre direction, to 90 mm. The machine code was edited to make the head follow the reference tow path with a constant tangential speed. The motor speed of the rewinding roller was adjusted to match the feed speed of the NCF with the tangential moving speed of the head.

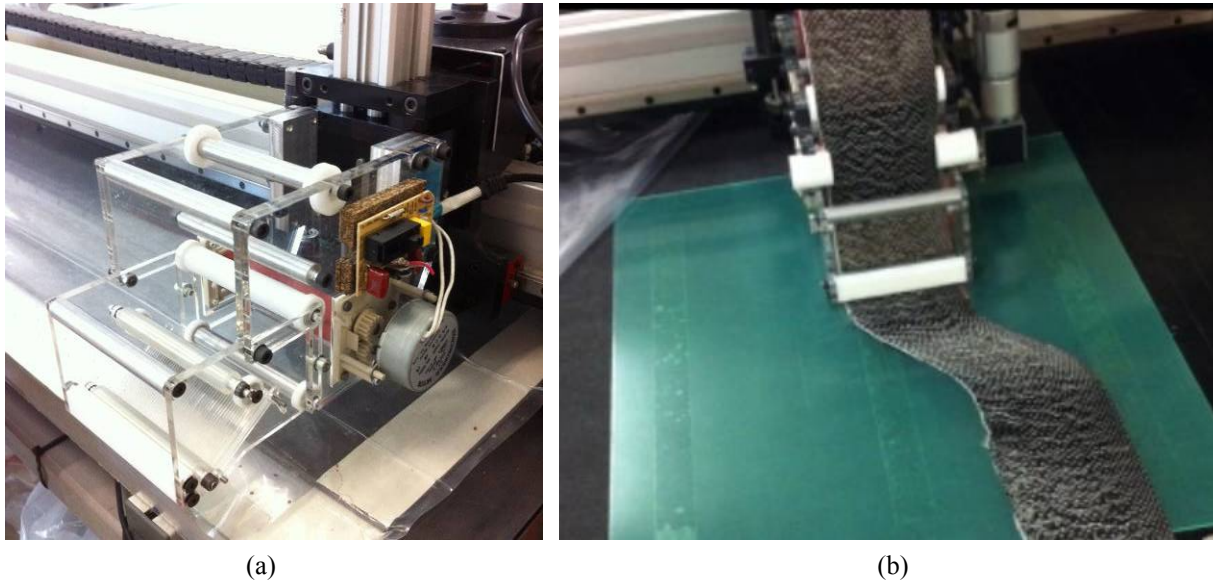

Figure 6. CMTS head: (a) module mounted on the prepreg cutting machine, (b) laying process.

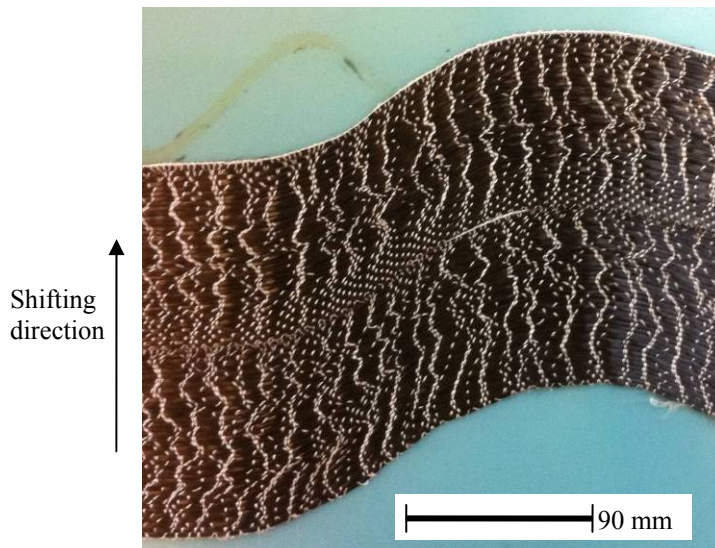

Figure 7. NCF steered by the CMTS.

Fig. 7 shows two NCF materials laid adjacently on the substrate. As shown in Fig. 7, every single tow within the NCF followed the same tow path which was simply shifted along the shifting direction although the positions of stitching yarns were slightly moved due to the contact of the compaction shoe. It was also revealed that the manufacturable radius of

curvature of the tow path was much smaller than that of the conventional AFP and any tow drop or overlap was not required to achieve a VAT design with perfectly shifted fibre paths.

#### 4 Limitations

Though the NCF material used in this work was a good alternative to improve the production speed of the CTS process by eliminating the in-situ impregnation process, its material characteristics resulted in a few limitations. Generally, the unidirectional NCF is heavily sized and its cross-section is close to an ellipse with a low aspect ratio because each tow is constrained by the stitching yarn. This makes each tow stiffer than common dry tows. Therefore, if it is used without treatment, each tow tends to be bent rather than sheared as shown in Fig. 8 (a). This can cause local fibre bucklings and resin pockets.

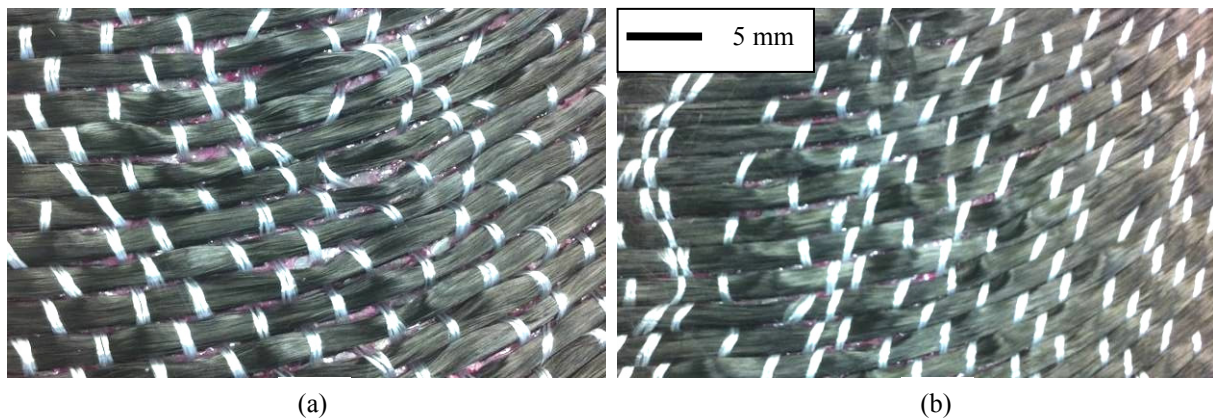

**Figure 8.** Unidirectional NCF laid by the CMTS technique: (a) sized NCF, (b) rewound NCF.

Fig. 8 (b) shows the sample which was laid after breaking the sizing material by winding it on a roller with a small radius and making it much more flexible. It was revealed that flexibility of the tow material affects the quality significantly. Nevertheless, at few locations the stitching yarns still induced the in-plane bending deformation by acting as supporting points. In addition, the material characteristic of the NCF limits the maximum shear angle. Fig 9 shows the cross-section of the NCF before and after shearing. As shown in Fig. 9 (a), the original shape has a low aspect ratio. As the shear angle increased, the aspect ratio became even smaller and reached around 1 at the shear angle of 45°, as shown in Fig. 9 (b). It is difficult to increase the shear angle more and make the tow thicker under compaction pressure.

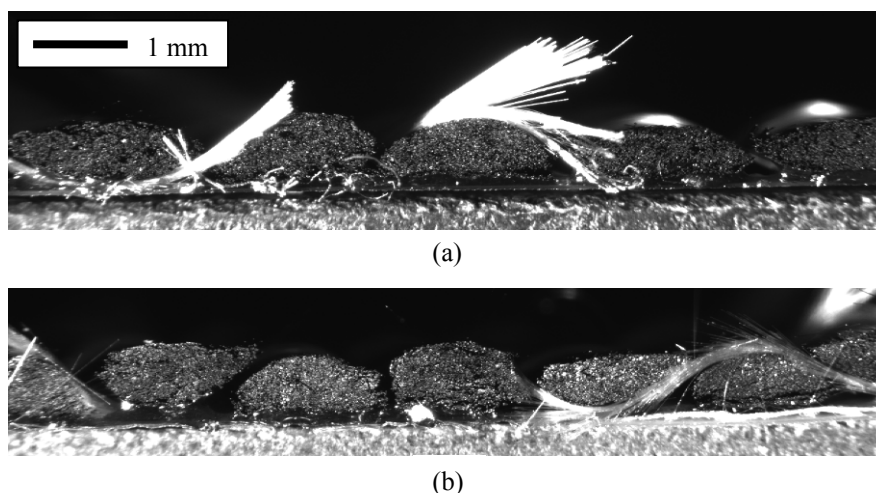

**Figure 9.** Cross-section: (a) shear angle = 0°, (b) shear angle = 45°.



From these results, it was found that the CMTS is more suited to manufacture VAT composite structures which have the tow paths with relatively small angle variation and where the less ideal laminate quality is acceptable.

## 5 Conclusions

In this research, the concept of CMTS (Continuous Multi-Tow Shearing) using the unidirectional NCF material was validated and its manufacturing characteristics were analyzed, which was an extended concept of the CTS (Continuous Tow Shearing) to improve the productivity by laying multiple tows. From the experiments, it was found that CMTS was an effective method to produce VAT composite structures with a reasonably good quality in high speed compared to the conventional AFP. Also, it could overcome the coupling problem between the productivity and design flexibility. However, due to the material characteristics of the NCF, it is thought to be limited to manufacturing VAT composites with a small angle variation range in terms of the process-induced defects and product quality.

## References

- [1] Gürdal Z, Olmedo R. *Composite laminates with spatially varying fiber orientations: variable stiffness panel concept* in: Proceeding of the AIAA/ASME/ASCE/AHS/ASC 33rd structures, structural dynamics and materials conference, Dallas, US, 1992.
- [2] Weaver PM, Potter KD, Hazra K, Saverymuthapulle MAR, Hawthorne MT. *Buckling of variable angle tow plates: from concept to experiment* in: Proceeding of the AIAA/ASME/ASCE/AHS/ASC 50rd structures, structural dynamics and materials conference, Palm Springs, US, 2009.
- [3] Lopes CS, Gürdal Z, Camanho PP. Tailoring for strength of composite steered-fibre panels with cutouts. *Compos Part A: Appl Sci Manuf*, 41, pp. 1760–7 (2010).
- [4] Kisch RA. *Automated fibre placement historical perspective* in: Proceeding of the SAMPE '06 international symposium, Long Beach, CA, 2006.
- [5] Blom AW, Stickler PB, Gürdal Z. *Design and manufacture of a variable-stiffness cylindrical shell* in: Proceeding of the SAMPE Europe 30th international conference, Paris, FR, 2009.
- [6] Beakou A, Cano M, Le Cam JB, Verney V. Modelling slit tape buckling during automated prepreg manufacturing; A local approach. *Compos Struct*, 93, pp. 2628-35 (2011).
- [7] Kim BC, Hazra K, Weaver PM, Potter KD. *Limitations of fibre placement techniques for variable angle tow composites and their process-induced defects* in: Proceedings of the 18th international conference on composite materials, Jeju, KR, 2011.
- [8] Kim BC, Potter KD, Weaver PM. Continuous tow shearing for manufacturing variable angle tow composites. *Compos Part A: Appl Sci Manuf* (doi: 10.1016/j.composite sa.2012.02.024, Accepted in 2012).