



Rodrigues, S., Chizhov, Anto, V., & Terry, J. R. (2008). Mappings between a macroscopic neural mass model and a reduced conductance-based model.

Early version, also known as pre-print

[Link to publication record in Explore Bristol Research](#)  
PDF-document

## University of Bristol - Explore Bristol Research

### General rights

This document is made available in accordance with publisher policies. Please cite only the published version using the reference above. Full terms of use are available:  
<http://www.bristol.ac.uk/pure/about/ebr-terms.html>

### Take down policy

Explore Bristol Research is a digital archive and the intention is that deposited content should not be removed. However, if you believe that this version of the work breaches copyright law please contact [open-access@bristol.ac.uk](mailto:open-access@bristol.ac.uk) and include the following information in your message:

- Your contact details
- Bibliographic details for the item, including a URL
- An outline of the nature of the complaint

On receipt of your message the Open Access Team will immediately investigate your claim, make an initial judgement of the validity of the claim and, where appropriate, withdraw the item in question from public view.

# Mappings between a macroscopic neural mass model and a reduced conductance-based model

Serafim Rodrigues, Anton V. Chizhov<sup>(\*)</sup> and John R. Terry

Department of Engineering Mathematics, University of Bristol, BS8 1TR

<sup>(\*)</sup>IOFFE Physical-Technical Institute, Russian Academy of Sciences, St Petersburg, 194021, Russia

April 29, 2008

## Abstract

We present two alternative mappings between a macroscopic neural mass model and a reduction of a conductance-based model. These provide possible explanations of the relationship between parameters of these two different approaches to modeling neuronal activity. Obtaining a physical interpretation of neural mass models is of fundamental importance as they could provide direct and accessible tools for use in diagnosing neurological conditions.

**Keywords:** neural-field; conductance-based model; Ki sets; multiscale mapping.

## 1 Introduction

The brain is a multi-scale system with a complex hierarchical organization, which has been studied using several experimental techniques. This hierarchical organization varies from the level of the single neuron to that of whole brain regions. As these scales change, techniques for modelling the recorded activity alters from probabilistic (in some sense) to structured. Equally, the temporal dynamics vary from discrete events (i.e. spikes) to continuous rhythmic activity as may be observed via scalp EEG. Systematic experimental results on the multi-scale characteristics of the brain have motivated a number of theoretical approaches. In particular, under the *dynamical hypothesis* [1], mathematical models

have been proposed to successfully describe these levels of observed phenomena. For example, at the microscale, the Hodgkin-Huxley model [2] and related conductance-based models successfully explain the temporal dynamics of an individual neuron. Whilst at the macroscopic scale, *Neural field* models [3, 4, 5], *Neural mass* models [6, 7, 8, 9] and models based on *Population density* [10] are employed to describe dynamical activity of LFP and EEG. To analyse complex systems, techniques such as *separation of scales* can be employed to enable mathematical analysis. However, it is not apparent that a physiological equivalent of separation of scales exists in the brain and is still a source of debate among neuroscientists. One explanation for the uncertainty of this approach in neuroscience is the fact that many processes in the brain operate on several spatial and/or temporal scales, hence providing strong interactions between them. For instance, neurons produce spikes whose timing is in some cases up to a millisecond precise [11]. On the other hand, there are examples showing that a lot of information is transmitted between neurons via variations in the average firing rate, which occur in the time scales of hundreds of milliseconds [12]. Thus, it is unclear when and how to ‘coarse-grain’ in order to move from one scale to another, as well as if this procedure is valid at all. Despite this, mathematical techniques have been developed, two approaches in particular are widely used to study neural field models. One approach by Ermentrout [13] utilizes thermodynamic theory which describes the activity of all neurons within a population by a single macroscopic variable. A similar derivation, which holds for averaging over Poisson inputs for a large network, used in conductance based models was introduced by Shriki [14]. However, to date, mappings have not been suggested to relate these two levels of activity and this motivates the current work.

One area of importance is the modelling of human EEG using macroscopic models, as it has been suggested that tracking dynamical changes in these models could be applicable in diagnosis of neurological disorders [15, 16, 17]. In particular, the transition to generalized seizure states was observed to be linked to bifurcations arising out of a variation of a parameter representing the strength of connectivity between cortex and the specific relay nuclei in the thalamus [16, 18, 19]. Since the parameters of the macroscale models considered are lumped together, they do not have a direct physical interpretation. However by developing a mapping between scales, some understanding of the relationship between parameters at

the macroscale and physiological parameters of reduced conductance-based models would be obtained.

## 2 Description of the modelling approaches

### 2.1 Macroscale

At the macroscopic level, the model we consider is a neural-mass model that was formulated by Freeman, who used the phrase 'Ki set hierarchy' where  $i = \{0, I, II, III\}$ . These sets are both a model of population dynamics and a description of the connectivity architectures to describe interactions made by neural masses and are based upon detailed analysis of experimental data. The K0 set, is the simplest component and models a neuronal ensemble forming part of a cortical column within which all neurons share the same physiological and functional properties. They receive spatial inputs (from dendrites) that are weighted and summed. Further they include a soma where pulse spike densities are produced and the internal dynamics (the transmembrane potential of a neuron) follow a linear time invariant system with second order dynamics. The output is then shaped by a nonlinear saturating function (essentially providing a measure of the relationship between the transmembrane potential and the pulse density of the neuronal mass. The response to some impulse function  $P(\vec{x}, t)$  is described as follows:

$$\begin{cases} \frac{d^2}{dt^2}V(\vec{x}, t) + (\alpha + \beta)\frac{d}{dt}V(\vec{x}, t) + \alpha\beta V(\vec{x}, t) = \alpha\beta P(\vec{x}, t), \\ \phi(\vec{x}, t) = \varsigma(V(\vec{x}, t)), \end{cases} \quad (1)$$

where  $\vec{x}$  is a spatial vector which at a macroscopic scale varies continuously over some domain.  $V(\vec{x}, t)$  is the transmembrane potential at the 'soma' of the neural mass.  $\varsigma(\vec{x}, t)$  is a sigmoidal function relating the  $V(\vec{x}, t)$  to the pulse density,  $\phi(\vec{x}, t)$ , of the neuronal ensemble. Finally,  $\alpha$  and  $\beta$  correspond to the inverse rise and decay times of the response signal. Observing the dynamics of the first equation it could be argued that they correspond to post synaptic dendritic responses of a single neuron, only here represented by aggregated synaptic events, which is precisely the interpretation given by *lumped parameter models* [7]. However, the precise relationship between the electrical potentials of single dendrites and the resulting summed dendritic potential of an ensemble of neurons is unclear. In fact, Freeman leaves the interpretation of these equations as an open problem. Nevertheless, in the literature,

authors assume them to be related to dendritic responses and different models of macroscopic rhythms, such as alpha oscillations and slow-waves seen in sleep and epilepsy have been developed [16]. Adopting this interpretation, Equation (1) may be written as follows:

$$V(\vec{x}, t) = l \int_{-\infty}^t K(t - t') P(\vec{x}, t') dt'. \quad (2)$$

Here, observables are now represented by local averaged values of a physiological process and it relates the averaged induced transmembrane voltage  $V(\vec{x}, t)$  at the soma with the mean potential  $P(\vec{x}, t')$  generated by action potentials arriving from other neurons at the dendrites of the post-synaptic neuron. The induced transmembrane perturbation propagates along the dendrites and reaches the cell body with some attenuation ( $l$ ) and lag represented by the kernel  $K(t)$ . These depend on the distance of the synapse from the cell body. The form of the kernel of the convolution is usually given by:

$$K(t) = \begin{cases} \frac{\alpha\beta}{\beta-\alpha} (\exp(-\alpha t) - \exp(-\beta t)) & \alpha \neq \beta \\ \alpha^2 t \exp(-\alpha t) & \alpha = \beta \end{cases}$$

Note that the model suggested by Jansen [8], which is often used to model event-related potentials (ERPs), is equivalent to the Freeman formulation when  $\alpha = \beta$ .

At the next level of the hierarchy, a KI set is formed by two K0 sets and defines the coupling relationship between them. However, this structure allows populations to be only either exclusively excitatory or inhibitory and no auto-feedback is allowed. Extending this, a KII set consists of two KI sets (or four K0 sets). KII networks can function as an encoder of signals or as an auto-associative memory, [6, 20]. Mathematically, KII sets may have several fixed points and can also have limit cycle attractors depending on the parameters of the system and the initial conditions. We focus on a subset of the KII models denoted reduced KII sets(RKII). In this simplification only a coupled inhibitory and excitatory neuronal population is considered for each column. This may be modeled in the following form:

$$\left[ \frac{1}{\alpha} \frac{d}{dt} + 1 \right] \left[ \frac{1}{\beta} \frac{d}{dt} + 1 \right] V_i(\vec{x}, t) = \sum_{j \neq i} \nu_{ij} \phi_j(\vec{x}, t), \quad (3)$$

where  $i = \{I = \text{inhibitory}, E = \text{excitatory}\}$  and  $j = \{I, E, ext\}$ , with  $ext$  denoting external inputs. The potential  $P(\vec{x}, t)$  at a particular location comprises contributions from pulse densities  $\phi_j$  that represent signals propagating from other neural mass, hence  $P(\vec{x}, t) = \sum_{j \neq i} \nu_{ij} \phi_j(\vec{x}, t)$ . The conversion

from pulse density  $\phi_j$  to wave amplitude is implicit in the synaptic weights  $\nu_{ij}$  where  $\nu_{EI} \in \mathbb{R}^-$ ,  $\{\nu_{IE}, \nu_{Ext}, \nu_{Iext}\} \in \mathbb{R}^+$  and  $\nu_{EE} = \nu_{II} = 0$ , that is, self loops are not considered.  $\phi_{Ext}(t)$  represents external inputs to the column and in general these represent excitatory connections from other columns, since long range connections are only established by excitatory neurons. Note that synaptic weights are not directly measured experimentally and can only be inferred through modelling process. At a macroscopic scale these parameters can be interpreted as having the following form  $\nu_{ij} = N_{ij}g_j$  where,  $N_{ij}$  represent the mean number of connections from neural ensemble of type  $j$  on a population of type  $i$  [21]. The term  $g_j$  representing the size of the impulse response associated with synapses of type  $j$ .

## 2.2 Microscale

To model neuronal activity at the microscale level a conductance based model is employed. Conductance-based models are based on an equivalent electrical circuit, which were first suggested in the seminal work of Hodgkin and Huxley [2]. These models represent a minimal biophysical interpretation for an excitable cell in which current flow across the membrane is due to charging of the membrane capacitance and movement of ions through ion channels. The general mathematical formulation is as follows:

$$C_m(\vec{x}) \frac{dV(\vec{x}, t)}{dt} = - \sum_j g_j(\vec{x})(V(\vec{x}, t) - V_j(\vec{x}, t)) + I_{ext}(\vec{x}, t), \quad (4)$$

where for each  $j$ :

$$\begin{cases} g_j(\vec{x}) = \overline{g_j(\vec{x})} a_j^x b_j^y, \\ \frac{da}{dt} = \frac{a_\infty - a}{\tau_a(V(\vec{x}, t))}, \\ \frac{db}{dt} = \frac{b_\infty - b}{\tau_b(V(\vec{x}, t))}. \end{cases} \quad (5)$$

Equation (4) defines the time course of the neuron voltage  $V(\vec{x}, t)$  as a response similar to a resistance-capacitance ( $\tau_m(\vec{x}) = R(\vec{x})C_m(\vec{x})$ ) circuit where  $\tau_m(\vec{x})$  defines membrane time constant. This linear response is only valid for small current amplitudes. For large amplitudes, pulses are generated if the current exceeds some threshold value  $V^{thr}$ . Activation is also dependent on the sum of synaptic currents  $g_j(\vec{x})(V(\vec{x}, t) - V_j(\vec{x}, t))$  where  $g_j$  corresponds to the synaptic conductance,  $V_j(\vec{x}, t)$  denotes the Nernst potential (reversal potential) and  $(V(\vec{x}, t) - V_j(\vec{x}, t))$  is the driving force for current  $j$ .  $a, b$  are gating variables raised to small integers  $x, y$  respectively.  $a_\infty, b_\infty$  are the steady-state activation and inactivation

gating variable functions respectively and  $\tau_a(V(\vec{x}))$ ,  $\tau_b(V(\vec{x}))$  are the time constant of the synapses and are voltage dependent. Note that the basic assumptions in conductance-based models are:

1. The different ion channels in the cell membrane are independent from each other.
2. The activation and inactivation gating variables are voltage-dependent and independent of each other for a given ion channel type.
3. Each gating variable follows first-order kinetics.
4. Within a single cell compartment the extracellular space is isopotential.

### 3 Multiscale mapping

A fundamental question is how to map between these level of descriptions so that relationships between the detailed physiological parameters of microscale models and those of macroscale models can be established. A sketch representing what we are aiming to achieve is depicted in Fig 1. To address this question we derive two independent solutions to map between an RKII set and a conductance-based model. The first solution is based on neural field approaches, only here, a second order equation is derived. This solution confirms the interpretation given by lumped parameter models. The second solution provides an alternative interpretation to the RKII set, whereby the second order in voltage may not correspond purely to dendritic activity.

Suppose that for the activity at the microscale, the post-synaptic potential (PSP)  $V(\vec{x}, t)$  is calculated from a reduced intracellular conductance-based model with a linear integrator:

$$\begin{aligned}
 C_i \frac{dV_i}{dt} &= -g_{iL}(V_i - V_{iL}) + I_s \\
 I_s &= -g_{iE}(V_i - V_E) - g_{iI}(V_i - V_I) - g_{iExt}(V_i - V_{Ext}).
 \end{aligned} \tag{6}$$

Here  $R_i = 1/g_{iL}$  is the neuron's membrane resistance,  $V_{iL}$  is the resting potential of the cell,  $V_{Ext}$  is assumed purely excitatory,  $g_{iL}$  defines the specific neurone membrane conductance and  $\tau_{im} = R_i C_i$ . Excitatory synapses are generally mediated by NMDA and AMPA receptors and inhibitory synapses by

GABA receptors. The complex ionic gating variables are simplified by ignoring the detailed dynamics of transmitter concentration in the synaptic cleft. Instead, they are described by an explicitly time-dependent conductivity  $g_{ij}(t)$  that will open whenever a pre-synaptic spike from neuron  $j$  arrives, hence:

$$g_{ij}(t) = \int_{-\infty}^t g_{ij}^{syn}(t-s) \sum_{m \in \mathbb{Z}} \delta(s - t_{ij}^m) ds. \quad (7)$$

The synapse  $g_{ij}$  is a temporal convolution of the sequences of spikes  $\sum_{m \in \mathbb{Z}} \delta(t - t_{ij}^m)$  with some integral kernel  $g_{ij}^{syn}$  at time  $t$ .  $t_{ij}^m$  represents the  $m$ th spike arrival at the axon terminal of neuron  $j$  that synapses onto cell neuron  $i$ .

We first consider the mapping of lumped parameter models. All derivations hereafter will assume that a neuron is a zero dimensional entity i.e. we drop the spatial vector  $\vec{x}$ . Further, we assume all-to-all coupling within a neuronal population. Employing neural field theory it is possible to define macroscopic rate variables. Since lumped parameter models assume that the dynamics result from dendritic activity, this implies that the characteristic time-scale between arriving spikes is shorter than  $\tau_{ij}$  (the characteristic time-scale of the kernel  $g_{ij}^{syn}(t)$ ). This then allows us to substitute the spike train  $\sum_{m \in \mathbb{Z}} \delta(s - t_{ij}^m)$  by the rate of incoming spikes, say  $\phi_{ij}$ . If all post-synaptic neurons receive the same rate from pre-synaptic neurons, then the index  $i$  can be omitted, effectively giving a neuronal population in the firing rate,  $\phi_j$ . Furthermore, the time course of the postsynaptic potential  $g_{ij}^{syn}$  depends mainly on the postsynaptic cell  $i$  and which can be assumed to have the form  $g_{ij}^{syn}(t) = \overline{g_{ij}} G_{ij}(t)$ .  $G_{ij}(t)$  is related to the time-scale of the diffusion process of transmitters released in the synaptic cleft and  $\overline{g_{ij}}$  is the maximal conductance. Combining these, we re-write equation (7):

$$g_{ij}(t) = \overline{g_{ij}} \int_{-\infty}^t G_{ij}(t-s) \phi_j(s) ds = \overline{g_{ij}} G_{ij} \otimes \phi_j(t), \quad (8)$$

where the  $\otimes$  represents the convolution operator and:

$$G_{ij}(\cdot)^{-1} V_i = \sum_{n=0}^{\infty} \kappa_{in} \frac{\partial^n}{\partial t^n} V_i. \quad (9)$$

Phenomenologically, synaptic activity has a bi-exponential form representing the opening and closing of channels. Hence:

$$G_{ij}(t) = \frac{\tau_{ij}^r \tau_{ij}^d}{(\tau_{ij}^r - \tau_{ij}^d)} (e^{-t/\tau_{ij}^r} - e^{-t/\tau_{ij}^d}), \quad (10)$$



where  $\tau_{ij}^r$  and  $\tau_{ij}^d$  are the rise and decay times of the response.

Again, from the neural field theory, we will assume that the frequency of the pre-synaptic neuron varies slowly when compared to synaptic activity i.e.  $\tau_{ij} \ll \tau_{im}$ . This assumption permits separation of scales, however, in reality  $\tau_{im}$  and  $\tau_{ij}$  are of similar magnitude. Using separation of scales we can replace the fast dynamics by its asymptotic value  $V_i^\infty$  and then consider the evolution of the slow variables only. Further, we assume that voltage differences for all channels are constant. This follows implicitly from our first assumption. Whilst this might be reasonable for excitatory synapses, for inhibitory connections it is less clear whether this is a reasonable assumption. For example, consider  $g_{\text{AMPA}}(t)(V_i - V_{\text{AMPA}})$  which is an excitatory synapse, with reversal potential  $V_{\text{AMPA}} = 5\text{mv}$ . The resting potential of a pyramidal cell  $V_{iL} = -70\text{mv}$  with threshold  $V_i^{\text{thr}} = -50\text{mv}$ . Studies show the following amplitude difference  $|V_i - V_{\text{AMPA}}| \approx 70\text{mv}$ , but the fluctuations are very small  $\sigma_V \ll |V_i - V_{\text{AMPA}}|$ . Hence, it is possible to apply the approximation  $-g_{ij}(t)(V_i - V_j) \approx -g_{ij}(t)(V_{iL} - V_j) = g_{ij}c_{ij}$ , (for  $j=\text{AMPA}$  or  $\text{NMDA}$ ), where  $c_{ij} = V_j - V_{iL}$  are now constants. In contrast, using this procedure for the inhibitory synapse  $g_{\text{GABA}}(t)(V_i - V_{\text{GABA}})$  is not valid, since  $V_{\text{GABA}} = -70\text{mv}$  and fluctuations are large  $\sigma_v \approx 10\text{mv}$ . However, these assumptions are required to derive the lumped model and allow the determination of the asymptotic voltage by setting  $\frac{dV_i}{dt} = 0$ , which has the following form:

$$V_i(t) = V_i^\infty(t) = V_{iL} + \frac{1}{g_{iL}} \sum_j g_{ij}c_{ij} + \frac{I_{iExt}}{g_{iL}}. \quad (11)$$

Assuming that the rise and decay times are the same for all synapses, i.e.  $\tau_{ij}^r = \tau_i^r$ ,  $\tau_{ij}^d = \tau_i^d$ ,  $G_{ij}(t) = G_i(t)$  and substituting these together with equation (8) into equation (11) results in the following:

$$V_i(t) = V_{iL} + \frac{1}{g_{iL}} \sum_j \bar{g}_{ij}c_{ij}G_i(t) \otimes \phi_j(t) + \frac{I_{iExt}}{g_{iL}}.$$

Applying the reverse operator  $G_i^{-1}$  we get the following macroscopic model:

$$[\tau_i^r \frac{d}{dt} + 1][\tau_i^d \frac{d}{dt} + 1]V_i = \sum_j \bar{g}_{ij}c_{ij}\phi_j(t) + V_{iL} + \frac{I_{iExt}}{g_{iL}}. \quad (12)$$

Note that the inverse operator  $G_i^{-1}$  either assumes that  $V_{iL}$  and  $\frac{I_{iExt}}{g_{iL}}$  are constants or that  $I_{iExt}$  changes slower than  $\tau_i^d$ . Averaging over large number of inputs and over an ensemble of neurons we obtain an

equivalence of the lumped parameter model (3) and equation (12). This mapping allows the following interpretations of the parameters:  $\tau_i^r = 1/\alpha$ ,  $\tau_i^d = 1/\beta$  and the synaptic couplings  $\nu_{ij} = \overline{g_{ij}}c_{ij}$ . Without lose of generality we can set  $V_{iL} = 0$ .

We now consider Freeman's model where the precise meaning of the voltage is unspecified. For this we assume the time scales of the membrane voltage and synaptic activity have the same order of magnitude. To map between an RKII set and a conductance model we wish to reduce Equation (10). A possible simplification is to assume that the response rises infinitely fast, i.e.  $\tau_{ij}^r = 0$  and the decay time is finite. This can be justified for small times scales and high frequency inputs, giving rise to the following first order response:

$$\tau_{ij}^d \frac{dg_{ij}(t)}{dt} + g_{ij}(t) = \overline{g_{ij}} \hat{\tau} \phi_j(t), \quad (13)$$

where  $g_{ij}$  is now a conductance, not a rate variable. Hence, we introduce a time-scale parameter  $\hat{\tau}$ . Applying the same procedure as before, the synaptic currents  $I_s$  in the conductance model (6) are simplified to  $I_s = -g_{iE}(V_i - V_E) - g_I^p(V_i - V_I) - g_{iExt}(V_i - V_E) \approx c_{iE}g_E + c_{iI}g_I + c_{iE}g_{iExt}$ . Multiplying both sides of equation (13) by  $c_{ij}$ :

$$\left[ \tau_{ij}^d \frac{d}{dt} + 1 \right] c_{ij} g_{ij}(t) = c_{ij} \overline{g_{ij}} \hat{\tau} \phi_j(t). \quad (14)$$

Assuming  $j = \{I, E \text{ and } Ext\}$ , we obtain:

$$\begin{aligned} \left[ \tau_E^d \frac{d}{dt} + 1 \right] c_{iE} g_{iE}(t) + \left[ \tau_I^d \frac{d}{dt} + 1 \right] c_{iI} g_{iI}(t) + \left[ \tau_{Ext}^d \frac{d}{dt} + 1 \right] c_{iE} g_{iExt} &= \\ \hat{\tau} (c_{iE} \overline{g_{iE}} \phi_E(t) + c_{iI} \overline{g_{iI}} \phi_I(t) + c_{iE} \overline{g_{iExt}} \phi_{Ext}(t)). & \end{aligned} \quad (15)$$

when summing over the three instances. Assuming all synaptic activity has the same time course

$\tau_I^d = \tau_E^d = \tau_{Ext}^d = \tau_{is}$  gives:

$$\left[ \tau_{is} \frac{d}{dt} + 1 \right] (c_{iE} g_E(t) + c_{iI} g_I(t) + c_{iExt} g_{Ext}(t)) = \hat{\tau} (c_{iE} \overline{g_{iE}} \phi_E(t) + c_{iI} \overline{g_{iI}} \phi_I(t) + c_{iE} \overline{g_{iExt}} \phi_{Ext}(t)) \quad (16)$$

$$\Leftrightarrow \left[ \tau_s \frac{d}{dt} + 1 \right] I_s = \hat{\tau} (c_{iE} \overline{g_{iE}} \phi_E(t) + c_{iI} \overline{g_{iI}} \phi_I(t) + c_{iE} \overline{g_{iExt}} \phi_{Ext}(t)).$$

Using equation (6) to obtain  $I_s$  and substituting into the above results in a second order in voltage

equation:

$$\begin{aligned}
\left[\tau_{is}\frac{d}{dt} + 1\right]\left[C_i\frac{dV_i}{dt} + g_{iL}(V_i - V_{iL})\right] &= \hat{\tau}(c_{iE}\overline{g_{iE}}\phi_E(t) + c_{iI}\overline{g_{iI}}\phi_I(t) + c_{iE}\overline{g_{iExt}}\phi_{Ext}(t)) \\
& \tag{17} \\
\Leftrightarrow \left[\tau_s\frac{d}{dt} + 1\right]\left[\tau_{im}\frac{d}{dt} + 1\right]V_i &= \frac{\hat{\tau}(c_{iE}\overline{g_{iE}}\phi_E(t) + c_{iI}\overline{g_{iI}}\phi_I(t) + c_{iE}\overline{g_{iExt}}\phi_{Ext}(t))}{g_{iL}} + V_{iL}.
\end{aligned}$$

For this mapping between (3) and (17) to be possible we must further assume that intracellular activity is in some way proportional to extracellular activity. Finally, comparing the left hand side of equations (16) and (17) we obtain a possible interpretation for the macroscopic parameters written as  $\frac{1}{\alpha} = \tau_{is}$  representing the synaptic time constant and  $\frac{1}{\beta} = \tau_{im}$  corresponding to the membrane time constant. Setting  $V_{iL} = 0$ , we also find a possible interpretation of the coupling parameters which differs from the usual assumed macroscopic formulation. Here we have  $\nu_{EI} = \frac{c_{EI}\overline{g_{EI}}\hat{\tau}}{g_{EL}}$  and  $\nu_{IE} = \frac{c_{IE}\overline{g_{IE}}\hat{\tau}}{g_{IL}}$ . The significance of this finding becomes apparent if within a neuronal population each neuron is modeled using a conductance-based approach. Averaging over a population with all to all coupling will provide a reasonable mapping to an RKII set. Furthermore, under the assumptions employed, it is now possible to relate the coupling parameters to slowly varying, low amplitude input currents. Finally, it is now possible to justify the second order in voltage as the time-scales of the synaptic activity and that of the soma are in some sense combined. An interesting avenue of research is to combine this work with recent studies showing that during EEG-Activated states not only there is an increase in firing rate of cortical neurons but also changes in the synaptic conductances and synaptic integrative properties [22]. The results presented therein, will be incorporated in the mapping outlined in this research in order to develop an enhanced EEG model that takes into account more detailed biophysical mechanisms.

## 4 Discussion

In this paper we represent three independent macroscopic approaches, namely Freeman [6], Lopes da Silva [7] and Jansen [8] into the same framework, subsequently mapping this to an underlying conductance-based approach. We provide two alternative routes, one of which is based on neural field approaches. The first approach we put forward is limited as separation of scales is required, which is still

a source of debate in the neuroscience community. On the other hand the second solution we present is preferred as no separation of scales is used. However, it is also limited by the assumptions applied but nevertheless provides insight as it is possible to justify the second order in voltage of the RKII set and link it directly to a population of conductance-based models. Future work will consider relaxation of the assumptions made, which will allow large amplitude currents, varying synaptic conductances and integrative properties to be incorporated. However, we envisage this to give rise to higher order terms in voltage, which suggests a reformulation of the 'Ki set hierarchy'. This might not be so much of an unexpected result since 'Ki set hierarchy' were derived phenomenologically to support experiments performed in the olfactory bulb [6]. In addition, we will consider time delays due to finite speed of axonal pulse propagation and delays involving time courses of different neurotransmitters, which play a crucial role in neuronal dynamics such as those observed in neurological disorders such as seizures [16, 18, 19]. In many cases, time delays are incorporated into a model as an approximation to a complex set of processes (e.g. ODEs) for which very often the true underlying mechanism is unknown. However, inclusion of time delays can reveal hidden dynamics that otherwise would be impossible to explain observed data, see for example [18, 19]. Equally important, it is necessary to ensure that the resulting simplified model verifies the observed data and correctly models the underlying biophysical system. Thus, we aim to develop an appropriate theoretical framework for mapping delays found in 'Ki set hierarchy' to conductance models. In particular, we are interested in mapping time delayed cortico-thalamic models [18, 19] to more detailed cortico-thalamic models such as those developed in [23, 24].

## 5 Acknowledgments

All authors acknowledge funding from the Leverhulme Trust Theoretical Neuroscience Network. The research was also supported by the EPSRC via Grant EP/D068436/01.

## References

- [1] T. V. Gelder. The dynamical hypothesis in cognitive science. *Behavioral and Brain Sciences*, 21: 615–665, 1988.
- [2] A. L. Hodgkin and A. F. Huxley. A quantitative description of membrane current and its application to conduction and excitation in nerve. *Journal of Physiology*, 117:500–44, 1952.
- [3] H. R. Wilson and J. D. Cowan. Excitatory and inhibitory interactions in localized populations of model neurons. *Biophysical Journal*, 12:1–24, 1972.
- [4] P. L. Nunez. *Neocortical Dynamics and Human EEG Rhythms*. Oxford University Press, 1995.
- [5] V. K. Jirsa and H. Haken. Field theory of electromagnetic brain activity. *Phys. Rev. Lett.*, 77:960, 1996.
- [6] W. J. Freeman. *Mass Action In The Nervous System. Examination of the Neurophysiological Basis of Adaptive Behavior through the EEG*. Academic Press New York San Francisco London, 1975.
- [7] F. H. Lopes da Silva, A. Hoeks, H. Smits, and L. H. Zetterberg. Model of brain rhythmic activity. the alpha rhythm of the thalamus. *Kybernetik*, 15:27–37, 1974.
- [8] B. H. Jansen and V. G. Rit. Electroencephalogram and visual evoked potential generation in a mathematical model of coupled cortical columns. *Biol. Cybern*, 73(357-366), 1995.
- [9] P. A. Robinson, C. J. Rennie, and D. L. Rowe. Dynamics of large-scale brain activity in normal arousal states and epileptic seizures. *Physical Review E*, 65(041924), 2002.
- [10] A. Omurtag, B. W. Knight, and L. Sirovich. On the simulation of large populations of neurons. *Journal of computational neuroscience*, 8:51–63, 2000.
- [11] M. J. Berry, D. K. Warland, and M. Meister. The structure and precision of retinal spike trains. *Proc. Natl. Acad. Sci. USA*, 94(10):5411–5416, 1997.
- [12] A. Borst and F. E. Theunissen. Information theory and neural coding. *Nat. Neurosci.*, 2(11): 947–957, 1999.

- [13] B. Ermentrout. Reduction of conductance based models with slow synapses to neural nets. *Neural Comp.*, 6:679–695, 1994.
- [14] O. Shriki, D. Hansel, and H. Sompolinsky. Rate models for conductance-based cortical neuronal networks. *Neural Comp.*, 15:1809–1841, 2003.
- [15] M. Le Van Quyen, J. Martinerie, C. Adam, and F. J. Varela. Unstable periodic orbits in human epileptic activity. *Physical Review E*, 56(3):3401–3411, 1997.
- [16] M. Breakspear, J. A. Roberts, J. R. Terry, S. Rodrigues, N. Mahant, and P. A. Robinson. A unifying explanation of primary generalized seizures through nonlinear brain modeling and bifurcation analysis. *Cerebral Cortex*, 16:1296–1313, 2006.
- [17] S. Rodrigues, J. R. Terry, and M. Breakspear. On the genesis of spike-wave activity in a mean-field model of human thalamic and cortico-thalamic dynamics. *Physics Letters A*, 355:352–357, 2005.
- [18] S. Rodrigues, D. Barton, R. Szalai, O. Benjamin, M. P. Richardson, and J. R. Terry. Transitions to spike-wave oscillations and epileptic dynamics in a human cortico-thalamic mean-field model. (submitted to *J. Comp. Neurosci.*), 2008.
- [19] F. Marten, S. Rodrigues, O. Benjamin, M. P. Richardson, and J. R. Terry. Onset of poly-spike complexes in a mean-field model of human EEG and its application to epilepsy. (to appear in *Phil. Trans. Royal Soc. Volume A*), 2008.
- [20] J. Principe, V. Tavares, J. Harris, and W. Freeman. Design and implementation of a biologically realistic olfactory cortex in analog VLSI. *Proc. IEEE*, 89(7):569–571, 2001.
- [21] J. J. Wright and D. T. J. Liley. Dynamics of the brain at global and microscopic scales: Neural networks and the eeg. *Behavioral and Brain Sciences*, 19:285–309, 1996.
- [22] M Rudolph, J. Guillaume Pelletier, D. Paré, and A. Destexhe. Characterization of synaptic conductances and integrative properties during electrically induced EEG-activated states in neocortical neurons in vivo. *Journal of Neurophysiology*, 94:2805–2821, 2005.

- [23] A. Destexhe and T. J. Sejnowski. *Thalamocortical Assemblies. How ion channels, single neurons and large-scale networks organize sleep oscillations*. Oxford University Press, 2001.
- [24] P. Suffczynski, S. Kalitzin, and F. H. Lopes da Silva. Dynamics of non-convulsive epileptic phenomena modeled by a bistable neuronal network. *Neuroscience*, 126:464–484, 2004.

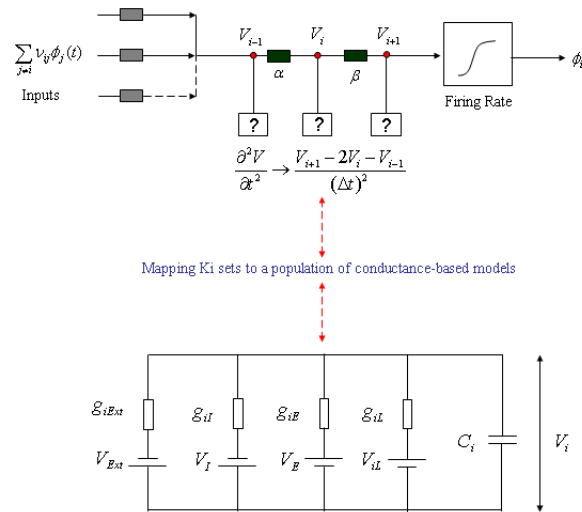

Figure 1: A sketch of a mapping between a 'Ki set' and a reduced averaged conductance-based model. At the macroscale, the 'ki set' receives inputs (firing rates) from other neuronal populations that are linearly summed to form the total activation to the cell. These inputs are then passed through a second order process, which is phenomenological, hence the question mark symbols as this is not an entirely understood process. Finally, the output of the 'Ki set' is a firing rate that would activate another neuronal ensemble. A reduced averaged conductance-based is used to explain the microscopic activity of a small neuronal population. The circuitry shown is based on an equivalent electrical circuit suggested by Hodgkin and Huxley [2]