



Sharp, B., Warr, P. A., Wilkinson, R. J., & McGeehan, J. P. (1998). The design of an analogue RF front end for a multi-role radio. 302 - 306. 10.1109/MILCOM.1998.722593

Link to published version (if available):  
[10.1109/MILCOM.1998.722593](https://doi.org/10.1109/MILCOM.1998.722593)

[Link to publication record in Explore Bristol Research](#)  
PDF-document

## University of Bristol - Explore Bristol Research

### General rights

This document is made available in accordance with publisher policies. Please cite only the published version using the reference above. Full terms of use are available:  
<http://www.bristol.ac.uk/pure/about/ebr-terms.html>

### Take down policy

Explore Bristol Research is a digital archive and the intention is that deposited content should not be removed. However, if you believe that this version of the work breaches copyright law please contact [open-access@bristol.ac.uk](mailto:open-access@bristol.ac.uk) and include the following information in your message:

- Your contact details
- Bibliographic details for the item, including a URL
- An outline of the nature of the complaint

On receipt of your message the Open Access Team will immediately investigate your claim, make an initial judgement of the validity of the claim and, where appropriate, withdraw the item in question from public view.

# THE DESIGN OF AN ANALOGUE RF FRONT END FOR A MULTI-ROLE RADIO

B A Sharp

Defence Evaluation and Research Agency  
Malvern, UK

P A Warr, R J Wilkinson, J P McGeehan

Centre for Communications Research  
University of Bristol, UK

## ABSTRACT

*The drive towards a Software-Defined Radio (SDR) in which much of the processing is controlled by reprogrammable digital hardware is placing new demands on the analogue RF front-end. In order to facilitate multi-role multi-mode operation, this must impose the minimum of constraints on the parameters that can be defined in software, while still offering performance which is at least as good as today's application-specific radios. This paper outlines some of the areas of research being carried out at the University of Bristol, funded by DERA, in an attempt to improve the flexibility and performance of the analogue RF front-end of a multi-role radio.*

## INTRODUCTION

Recent advances in analogue-to-digital conversion and digital processing technology have led to increasing interest in the concept of a Software-Defined Radio (SDR) [1]. Such a radio would have all its main operating parameters defined in software rather than hardware and would therefore be extremely flexible, with obvious benefits in both military and commercial applications. For the military, such technology would provide a method of combining a number of radios into one unit, providing savings in terms of size, weight, cost and logistics support. Its software programmability would also have benefits in terms of upgradability and inter-operation between nations, leading to shorter procurement cycles and an ability to respond more rapidly to advances in technology

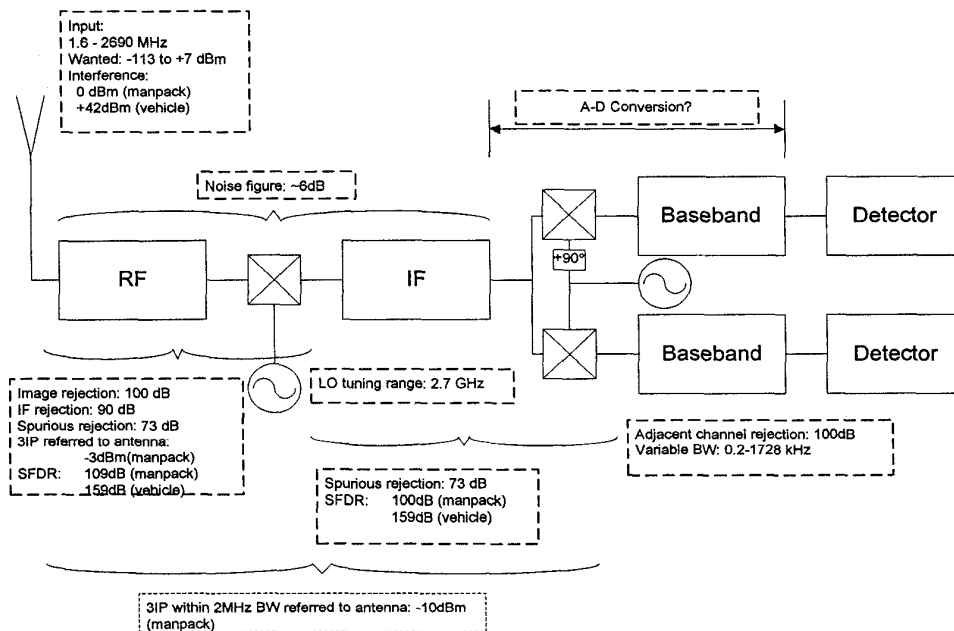

Figure 1: Outline specification for future military multi-role radio

and changing operational scenarios.

This paper discusses some aspects of the design of a software-defined radio, concentrating mainly on the analogue RF front-end. It begins by discussing the likely requirements for a military multi-role SDR, based on the performance of existing systems and standards, and then looks at possible architectures, identifying likely problem areas. Some of the research being carried out at the University of Bristol, funded by DERA is then described.

### REQUIREMENTS

Over the last two years, DERA has been looking at the potential of SDR techniques to enhance the performance of military communications. As the first stage of this work, a survey of the performance required of existing systems and standards was carried out in order to establish a rough specification for a military multi-role multi-band SDR. This survey enabled a comparison of the requirements of civil and military systems to be made, as well as helping to identify areas where the introduction of multi-band flexible radio architectures would impose new demands on the performance of the RF front end. The results are summarised in Figure 1, which shows a rough allocation of performance parameters to the front end of a typical superheterodyne radio.

From Figure 1, it can be seen that the main challenge posed by a multi-role radio is the requirement to provide an extremely wideband front-end, together with variable channel bandwidth, whilst still providing interference and noise performance comparable to or better than existing application-specific radios. This is true for both military and civilian applications. However, the military case is perhaps more severe, due to a wider range of possible frequencies and problems such as co-site operation and potentially hostile interference combining to create a congested electromagnetic environment.

### ARCHITECTURE

Ideally, a software-defined multi-role radio might consist of an entirely digital architecture, with only a minimal amount of processing carried out before digitisation, as illustrated in Figure 2. This approach would enable all processing to be carried out digitally, and therefore to be entirely reprogrammable and reproducible. Unfortunately, such an architecture would place unrealistic demands on the Analogue-to-Digital Converter (ADC) and digital signal processing speeds.

Looking at Figure 1, an ADC placed directly at the front-end of the receiver would be required to digitise over 2.5 GHz of spectrum with a Spurious-Free Dynamic Range (SFDR) of at least 120 dB or more in a vehicular role. A

typical state-of-the-art ADC aimed at software radio

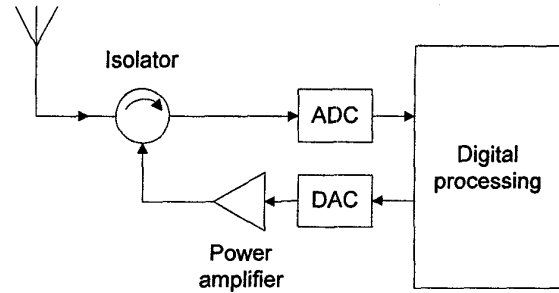

Figure 2: "Ideal" software-defined radio architecture

applications will offer a bandwidth of only 20 MHz with 80dB SFDR, well short of these requirements[2]. Significant improvements in ADC performance will therefore be required to make this approach feasible.

Even if such devices were available, it is likely that power considerations would prevent their use in mobile applications. Theoretical calculations of the power dissipation in the capacitive sample-and-hold stage of an ADC suggest that the minimum power consumption for a 5Gsample/s 18-bit resolution ADC would be more than 10W [3]. Therefore an 'ideal' software radio architecture is unlikely to ever be appropriate for a mobile multi-band radio without a revolution in the design of ADCs.

Such considerations mean that a multi-band SDR is likely to require an analogue RF front-end for the foreseeable future. This must be accomplished in a flexible manner in order to impose the minimum of constraints on the parameters which can be defined by the software, creating design challenges in both the transmit and receive chains. In both cases, the issue of local oscillator generation and tuning must be considered. This is a significant problem, but will not be discussed further here. For transmitters, the other main issue is that of amplification of a wideband signal in an efficient and linear manner. This has been the subject of in-depth research at the University of Bristol and elsewhere over recent years[4,5]. The focus of this work is therefore on the problems involved in the receiver chain, which have historically received much less attention.

A conventional application-specific receiver consists of several filter stages, used to progressively reduce the number and level of interfering signals and noise entering the receiver and therefore to reduce the instantaneous dynamic range required at each stage of the receiver chain. However, filters are generally of fixed frequency and bandwidth or have a very limited tuning capability, and this approach would therefore severely compromise the size and flexibility of a multi-band multi-role radio. Even

in conventional radios, the incorporation of fixed frequency filters is problematic, and accounts for a significant part of the volume, cost and performance of a mobile unit [6]. It would therefore be desirable to minimise the number of filters used.

Minimising the amount of filtering performed in the receiver chain in order to maximise the flexibility of the radio will require highly linear RF and IF stages. However, improved linearity alone will not be sufficient. In particular, for superheterodyne receivers there is the problem of rejection of the image signal. This must be suppressed before the mixer, either through filtering or some other technique, if it is not to interfere with the wanted signal. Another significant problem is that of duplexer elimination and the related problem of co-site interference. It is unlikely that the linearity and dynamic range of the front-end will ever be sufficient to cope with these very strong signals, and so some other method of cancellation must be found.

The remainder of this paper will briefly discuss work being done at the University of Bristol, funded by DERA, to address some of these problems.

### AMPLIFIER LINEARISATION

In wideband receiver systems where a high dynamic range is required, non-linear amplification cannot be used. Such amplifiers have a significant degree of intermodulation and harmonic distortion, both of which generate spurious outputs which limit the instantaneous dynamic range of the receiver.

There are two possible approaches to reducing these in-band spurious products: either avoid generating the products in the first place, or remove them after they have been generated using a linearisation technique. These two approaches are completely complementary.

Looking first at reducing the level of products generated; within an active amplification element the output non-linear distortion products are proportional to the current density within the device. Reducing the current density within an amplifier involves reducing the level of the input signal. One way of achieving this is through matched attenuation, which has the disadvantages that the gain is compromised and the Noise Figure (NF) increased by the amount of the attenuation. This will reduce the instantaneous dynamic range of the receiver.

A better approach to current density reduction is to split the input signal into a number of paths, amplify each signal separately and then recombine the paths in phase. Here, because the signal is split rather than attenuated, the loss with respect to a single channel in the splitting process can be reclaimed at recombination. Thus, the network NF

is dominated by that of the amplifier plus the excess insertion loss in the splitting stage. As the number of paths increases, the network complexity and excess insertion loss will rise, along with an increased gain/phase matching problem.

Further benefits can be gained from removing the products that have been generated. Of the available transmitter amplifier linearisation techniques, only two can potentially offer the required bandwidth and low NF required in multi-role SDR. These are post-distortion and feedforward.

Post-distortion involves inserting a network after the amplifier to compensate for its non-linearities. This should ideally leave only the linear gain component in the combined post-distortion amplifier network. The compensation network is based on a model of the amplifier transfer characteristics. However, as operational bandwidth increases, the accuracy of the model deteriorates. An initial investigation concluded that such RF post-distortion networks have appreciable loss, low levels of distortion compensation and poor wideband performance.

The feedforward technique is much more promising. The principle is summarised below.

- Generate an error signal containing only the distortion added by the amplifier.
- Amplify and subtract that error signal from the output of the amplifier.

A network suitable for carrying out this technique is shown in Figure 3. Its operation is described below.

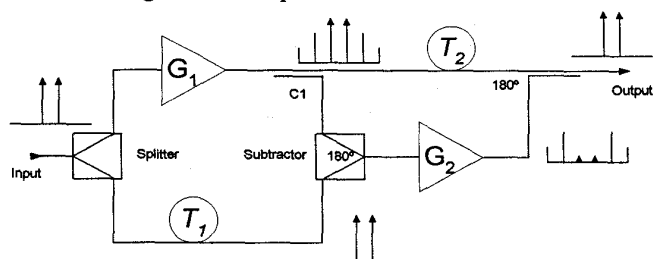

Figure 3: Feedforward linearisation architecture

The input signal is split to form two identical paths, although the ratio used in the splitting process need not be equal. The signal in the upper path is amplified by the main amplifier G1: this is where the distortion arises.

The directional coupler C1 takes a sample of the main amplifier output signal and feeds it to the subtractor, where a time-matched portion of the original signal, present in the lower path, is subtracted. The result of this subtraction process is an error signal containing predominantly the

distortion information from the main amplifier. Ideally, none of the original signal energy should remain.

The error signal is then amplified by error amplifier G2 to the required level and fed to the output coupler. The main signal path through coupler C1 is delayed by an amount equal to the delay through the amplifier G2, plus  $\pi$  radians, and fed to the output coupler in antiphase to the amplified error signal. The error signal will then cancel the distortion of the main path signal leaving, ideally, an amplified version of the original input signal.

The advantages of this technique can be summarised as follows:

- Low levels of distortion can be improved without difficulty.
- Operation over a very broad bandwidth is possible.
- The process compensates for the gain and phase non-linearities of the main amplifier.
- A relatively low NF may be obtained (see below).

The NF of a feedforward amplifier is dominated by the elements of the system which are not included in the correction process. This is because noise is treated in the same manner as distortion and is suppressed by the network. Optimising the feedforward architecture for a low noise amplifier application involves minimising the losses from the RF input to the error amplifier along the reference path.

Some development work has been carried out to look at the use of the feedforward technique to produce a low-noise linearised amplifier for a DCS1800 receiver front-end [7]. This has demonstrated that the technique is applicable for low-noise linearisation over a bandwidth of 1700-1800 MHz. Work is now being done to look at extending the bandwidth of operation by an order of magnitude to meet the needs of a multi-band receiver front-end.

### IMAGE REJECTION

In a conventional narrowband receiver, the image rejection problem can be resolved by pre-selection filtering before the mixer. However, in a multi-band receiver, this is no longer possible unless tuneable or switched filters are used, since the possible range of wanted frequencies will overlap the possible range of image frequencies unless a very high first IF is used.

Image rejection mixing, which was first proposed by Hartley [8] offers an alternative approach which does not depend on filtering. The basic approach, illustrated in Figure 4, relies on very close matching between the two signal paths in terms of both gain and phase in order to provide sufficient rejection. For example, to meet the 100 dB image rejection offered by existing CLANSMAN

combat net radios entirely through this technique would require an accuracy of 0.0001 dB and 0.001 degrees. At present, carefully manufactured image rejection mixer ICs can only achieve a maximum of 35dB image rejection, over a limited frequency band[9], it is therefore unlikely that the levels of performance required will ever be met through careful manufacturing techniques alone.

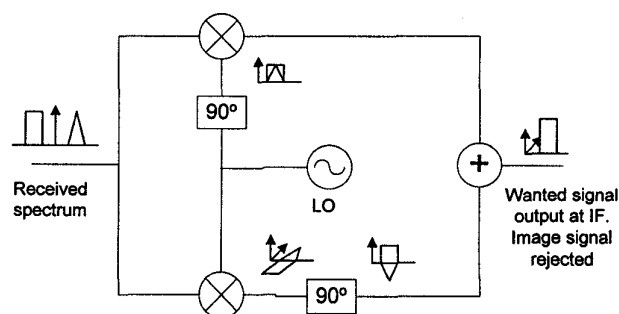

Figure 4: Image rejection mixer

Previous researchers have looked at methods of improving the performance of the 90 degree phase shifters, which are the main source of error within the system [10,11]. However, in order to offer very high levels of rejection, a different approach must be taken, looking at the matching of the whole system, and not just one component part. Work is therefore being carried out to look at possible implementations of a high performance image rejection mixer.

### IF LINEARISATION

In an SDR receiver, all the channel selection and demodulation will be performed in the digital domain. The RF spectrum mixed down to the IF may contain a single broadband signal, or a large number of individual narrowband signals, some or all of which may be demodulated in parallel. This necessitates the use of a final broadband "digital IF" which can be sampled directly with a high-resolution ADC. This IF may therefore cover a large bandwidth at low frequencies: for example 1 to 10 MHz constitutes a decade range. The IF amplifier must preserve the dynamic range achieved by the front-end of the receiver, so both low noise and low distortion should be maintained.

The feedforward technique previously described is well-suited to this task, but great care must be taken in order to

achieve good distortion cancellation across such a wide relative bandwidth. This requires that the amplifiers and signal couplers used have very flat frequency responses, so that the two paths in each loop may be well-matched. In a laboratory prototype system using two nested feedforward networks, the input intercept point of an IF amplifier was improved by 41dB, whilst the noise figure was only degraded by 4dB.

#### SUMMARY

Recent increases in the cost and availability of digital processing power have meant that the concept of a multi-role software-defined radio is a real possibility. However, the present and likely future performance of ADCs means that an analogue RF front-end will still be required to perform some initial processing of the incoming spectrum. This RF front-end must be implemented in an extremely flexible manner in order to enable its operation to be defined in software rather than hardware.

This requirement creates a number of challenges for RF designers, due to the lack of suitable tuneable filters operating at RF and IF frequencies. Bristol University, funded by DERA, are looking at a number of techniques to compensate for a reduction in filtering and therefore enable a more flexible and upgradable multi-role radio to be built.

#### REFERENCES

- 1 Special Issue on Software Radio, IEEE Communications Magazine, May 1995
- 2 Analog Devices AD9042 data sheet, Rev A, 1996
- 3 P B Kenington, "DRA Flexible Transceiver Systems Project: Report on a simulation study into aspects of a flexible receiver system", University of Bristol, May 1997
- 4 A Bateman, R Wilkinson, "Linearisation of class C amplifiers using cartesian feedback", Proceedings of IEE Workshop on Mobile & Cordless Telephone Communications, London, September 1989.
- 5 P B Kenington, R J Wilkinson, J Marvill, "A multi-carrier amplifier for future mobile communications systems", Proceedings of the 6th IEE International Conference on Mobile and Personal Communications, Warwick, UK, December 1991, pp 151-156
- 6 G Kannell, D Gabbay, "Filter design for cellular applications", RF Expo West 1994, p62-7
- 7 P A Warr, P B Kenington, M A Beach, "Feed forward linearisation in high dynamic range receivers", ACTS Mobile Communications Summit October 1997, pp839-844
- 8 R V L Hartley, "Modulation system", US patent 1 666 206, April 17 1928
- 9 UAA2067G Image reject 1800 MHz transceiver for DECT applications, Philips data sheet, Oct 1996
- 10 D Pache, JM Fournier, G Billiot, P Senn, "An improved 3V 2GHz BICMOS image reject mixer IC", IEEE Custom integrated circuits conference, May 95, pp95-8
- 11 A Teetzel, "Design of a wideband IQ modulator", Hewlett-Packard 1997 RF Design Seminar