



Nesimoglu, T., Canagarajah, C. N., McGeehan, J. P., & Wilkinson, R. J. (2000). A novel wideband active feedback amplifier linearization scheme suitable for handsets. 1712 - 1716. 10.1109/VETECS.2000.851564

Peer reviewed version

Link to published version (if available):
[10.1109/VETECS.2000.851564](https://doi.org/10.1109/VETECS.2000.851564)

[Link to publication record in Explore Bristol Research](#)
PDF-document

University of Bristol - Explore Bristol Research

General rights

This document is made available in accordance with publisher policies. Please cite only the published version using the reference above. Full terms of use are available:
<http://www.bristol.ac.uk/pure/about/ebr-terms.html>

Take down policy

Explore Bristol Research is a digital archive and the intention is that deposited content should not be removed. However, if you believe that this version of the work breaches copyright law please contact open-access@bristol.ac.uk and include the following information in your message:

- Your contact details
- Bibliographic details for the item, including a URL
- An outline of the nature of the complaint

On receipt of your message the Open Access Team will immediately investigate your claim, make an initial judgement of the validity of the claim and, where appropriate, withdraw the item in question from public view.

A Novel Wideband Active Feedback Amplifier Linearization Scheme Suitable for Handsets

T. Nesimoglu, C. N. Canagarajah, J. P. McGeehan and R. J. Wilkinson

Center for Communications Research, University of Bristol,
University Walk, Bristol BS8 1TR, United Kingdom
E-mail: T.Nesimoglu@Bristol.ac.uk, Tel: 0117 928 8618

Abstract – A new active feedback network is proposed for reducing intermodulation distortion (IMD). It is based on using the existing second harmonic zone (SHZ) distortion energy generated by the amplifier to predistort the input signals optimally to obtain a linear output. The technique is analyzed theoretically and practical results demonstrate the linearization performance. The measured two-tone test showed 23-dB reduction in the third-order intermodulation products (IMP_3), where $\pi/4$ DQPSK and W-CDMA gave up to 15-dB and 13-dB adjacent channel interference (ACI) suppression respectively. This technique differs from available active feedback techniques by performing both with narrow and wideband modulated signals. The linearization circuitry is simple and small in size.

I. INTRODUCTION

The rapidly increasing number of users and services in mobile communication systems requires efficient usage of the available frequency bandwidth. Therefore, spectrum efficient modulation systems such as DQPSK or W-CDMA are considered for high bit rate data transmission. Both of these systems have envelope variations in their signal levels. When a PA amplifies such signals, IMD will be produced and the output spectrum will spread over a wider bandwidth. This causes ACI and violates the emission specifications in communication systems. Therefore, channel spacing in a multichannel system has to be increased to reduce this interference, which also reduces the spectral efficiency by allowing fewer channels in the available bandwidth. One solution is to use a larger PA that will be linear over the range of the input signal. However, this is not preferred since it is a power inefficient solution. The efficiency of the transmitter is critical where the power source is limited, as in a mobile handset. This has motivated the research into linearizing PAs in transmitters to increase the spectral efficiency by reducing the distortion level.

Available linearization techniques use complex circuits and are expensive to produce. These factors make them difficult to be applied to small amplifiers for mobile equipment. The Feedforward technique [1-2] requires another amplifier, which reduces the overall efficiency of the amplifier circuit. Also it is very sensitive to the

matching of the two loops required in the system. Extensive research has been carried out and results are obtained for an adaptive feedforward system [3-4]. Cartesian Feedback [5-7] requires a complex feedback loop, and is an efficient technique for narrowband modulation schemes. Predistortion techniques [8-10] linearize the PA by creating the inverse of the nonlinear characteristics of the amplifier, so that the overall transfer function becomes linear. The predistortion is an open loop system. It is sensitive to amplifier parameters and input power changes, so adaptivity is considered to overcome these problems. Therefore digital signal processing (DSP) is applied to the predistorter, where a DSP chip, downconverters, A/D converters and demodulators are needed, the result is a large and expensive amplifier circuit.

Active feedback techniques have been widely investigated [11-13] for linearization purposes. Although promising IMD suppression has been obtained with simple circuitry, the linearization bandwidth was within kHz. Also linear gain reduction and a possibility of oscillation was observed. Second Harmonic Feedback (SHF) has been previously investigated [14-15] by computer simulation. Practical prototypes [16] showed 14-dB of IMP_3 reduction within 8 MHz of bandwidth in a two-tone test without any reduction in the amplifier gain. In this paper a new linearization configuration is presented. It is a combination of active feedback and SHF. It combines the advantages of both. The main advantages are:

- Compared to other linearization schemes, this technique requires a smaller and simpler circuit. It can be used in a handset or combined with other linearization techniques producing a hybrid scheme.
- Using the novel idea of a nonlinear active element on the feedback loop eliminates the need of a loop filter, which was used in the previous feedback amplifiers to suppress the oscillation. This reduces the delay of the feedback loop, improving the stability, linearization performance and bandwidth.
- The fundamental and SHZ loop gains can be adjusted by the nonlinear active element. This enables to maximize the IMD suppression with minimum reduction in the amplifier gain. Gain loss is related to the loop gain at fundamental frequencies and therefore minimizing this reduces the gain loss.

- Active feedback techniques operating principles are, in a certain way similar to those of the analog predistortion systems. In predistortion, even if the AM-AM characteristics of the auxiliary and main amplifier are inversely matched, the AM-PM characteristics of both amplifiers add together unless they are opposite. This is difficult to achieve and should be avoided since AM-PM conversion effect increases IMD [17].
- The amplifier gain is stabilized against slowly changing circuit parameters due to temperature and aging. Therefore it does not require control circuits to maintain the optimal conditions for linearity.

The organization of the paper is as follows. In Section II, the theoretical justification is provided. In Section III, the results obtained by using the first distorter are presented and linearization bandwidth is investigated. In Section IV the performance of the circuit is improved even further by using our second distorter. The results obtained by TETRA $\pi/4$ DQPSK and W-CDMA shows the performance of the circuit with both narrowband and wideband modulated signals.

II. THEORY

The Volterra series is used as an analysis tool in many nonlinear systems [18]. It is a generalization of power series and ideal for representing frequency dependent small nonlinearities. Narayanan [19] has derived a set of Volterra kernels for an overall feedback amplifier ($G_1(f_1)$, $G_2(f_1, f_2)$, $G_3(f_1, f_2, f_3)$) in terms of feedback network ($B_1(f_1)$) and main amplifier kernels ($A_1(f_1)$, $A_2(f_1, f_2)$, $A_3(f_1, f_2, f_3)$). The representation of these Volterra kernels of a feedback amplifier and the equivalent system is shown in Fig. 1. The equations derived (1-2) can be used to analyze the effects of feedback on the nonlinear distortion of amplifiers up to cubic nonlinearity. The analysis considers three input tones (f_1, f_2, f_3), but it can be related to two-tone test as well, if: $(\pm f_1 \pm f_2 \pm f_3) = (2f_1 - f_2)$ or $(2f_2 - f_1)$.

$G_1(f)$ is the well-known feedback amplifier linear gain equation. It shows that the reduction of linear gain depends only on the loop gain at the fundamental frequencies ($B_1(f)A_1(f)$). $G_2(f_1, f_2)$ shows the second order IMPs, which does not appear in the fundamental zone, therefore it is not shown here. $G_3(f_1, f_2, f_3)$ shows that cubic nonlinearity is directly related to two factors: The loop gain at the fundamentals (first term), and loop gain at the third-order product frequencies (third term). Cubic nonlinearity can be reduced by feedback at both of these frequencies. But the loop gain at fundamental frequency will also reduce the linear gain of the amplifier while reducing IMP_3 (1). On the other hand, feeding back only third-order products without fundamentals will not reduce linear gain, but it is a complex process and requires an efficient feedforward loop. In equation (2), it is important to see that reducing cubic nonlinearity in feedback systems not only depends on the loop gain at the fundamental frequencies but also at the third-order

distortion products and second harmonic frequencies as well. The second term is a result of interaction of the feedback second harmonics ($f_2 + f_3$) with a first order input term of the second-degree open loop kernel ($A_2(f_1, f_2 + f_3)$). This interaction creates extra IMP_3 , depending on the phase of the loop gain at second harmonic frequencies. If these additional products can be generated out of phase with the originals, IMP_3 cancellation can be achieved and this will not affect the linear gain of the amplifier (1). In adjusting the phase and gain at second harmonic frequencies, care should be taken since incorrect parameters can instead increase the cubic nonlinearity.

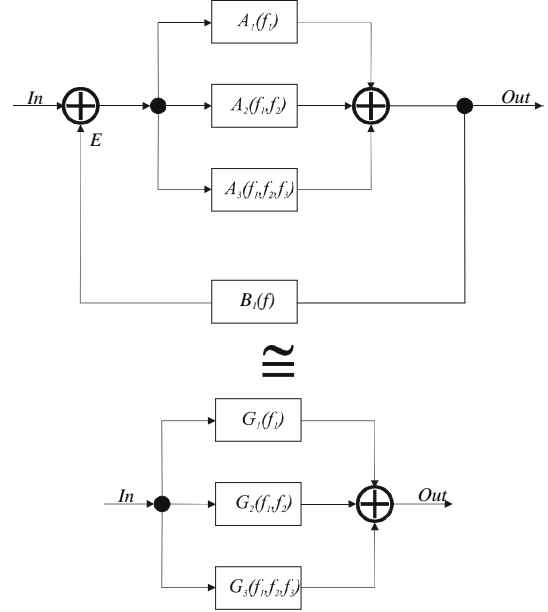

Fig. 1. Feedback amplifier representation and equivalent system showing Volterra kernels.

$$G_1(f) = \frac{A_1(f)}{1 + B_1(f)A_1(f)} \quad (1)$$

$$G_3(f_1, f_2, f_3) = \left[\frac{A_3(f_1, f_2, f_3) \prod_{i=1}^3 \left(\frac{1}{1 + A_i(f_i)B_1(f_i)} \right) - 2A_2(f_1, f_2 + f_3)}{\frac{1}{1 + A_1(f_1)B_1(f_1)} B_1(f_2 + f_3)G_2(f_2 + f_3)} \cdot \left(\frac{1}{1 + A_1(f_1 + f_2 + f_3)B_1(f_1 + f_2 + f_3)} \right) \right] \quad (2)$$

This technique uses feedback of both fundamental and SHZ. If optimum levels of fundamentals and second harmonics can be obtained with correct phase relations, maximum IMD suppression with minimum reduction in the amplifier gain can be achieved.

III. FEEDBACK WITH DISTORTER I

The feedback prototype was built as shown in Fig. 2. A 20-dB directional coupler samples the output of the

power amplifier P_{out} . The distorter (δ) amplifies the SHZ at 900 MHz and attenuates the fundamental signals at 450 MHz. It is an active element with variable resonant circuits at its input and output ports. By this method the power level in the SHZ is increased without any amplification of the fundamental signals. The attenuation of the fundamental signals is manually adjusted from the distorter to obtain maximum reduction of IMD with minimum level of feedback fundamental signals. As shown before feeding back significant levels of fundamental signals reduces the gain of the PA and makes the stability more critical [16-18]. Also using our distorter eliminates the requirement of a bandpass filter, which introduces delay in the feedback loop, again improving the stability and simplicity of the feedback amplifier. The gain response of the distorter is shown in Fig.3. After distorting the sampled output, phase and amplitude adjustment was made with voltage-controlled phase shifter and attenuator. The output of the feedback path P_{inj} is then injected into the amplifier together with the fundamental signals P_{in} . The amplifier used in the experiment is a MIMIC amplifier with a gain of 33-dB. The inputs to the amplifier are the two tones at frequencies 430 MHz and 450 MHz with -23 -dBm common power level, which is the 1 dB compression point of the PA. The only requirement in this technique will be the PA's capability to operate at the feedback signal frequencies (SHZ) and the loop gain should not exceed 1, when it has 180° phase difference associated with the input signals. The results obtained with and without feedback are shown in Fig. 4; note that IMP_5 are reducing about 10-dB together with a 24-dB IMP_3 reduction. There is no reduction in the amplifier gain.

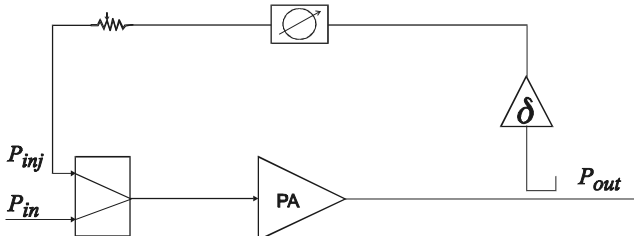

Fig. 2 Active feedback amplifier block diagram.

The performance of this feedback circuit was investigated with changing frequency separation between the two tones, to determine the linearization bandwidth. Fig. 5 shows the response obtained with changing frequency separation, each one of the plots represents one of the IMP_3 . The initial frequency separation between the two input signals is 20 MHz and the feedback loop was set to obtain the maximum reduction of IMP_3 at this point. Increasing or decreasing the frequency separation by 1 MHz steps without changing the feedback loop parameters degrades the performance. This prototype shows that at least 8-dB improvement may be achieved with signal bandwidths up to 30 MHz, but note that the feedback may be optimized for one particular bandwidth. There may be an advantage in using this to help an amplifier satisfy a particular spectral emission mask.

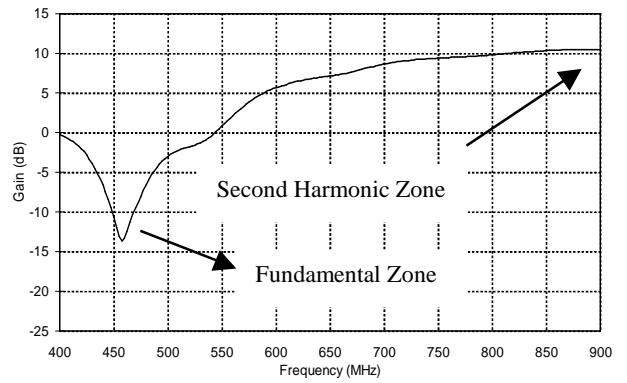

Fig. 3 Gain characteristics of the first distorter.

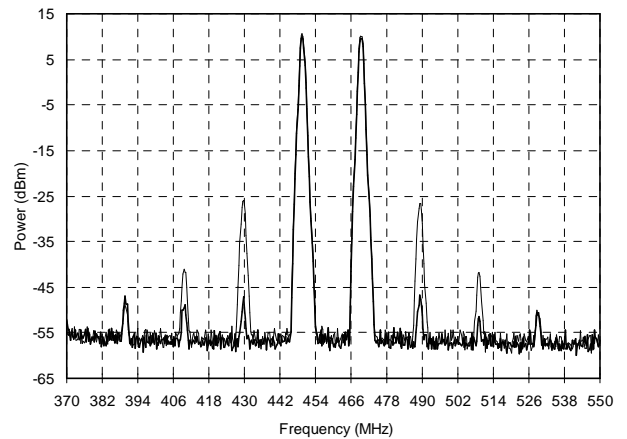

Fig. 4 Harmonic feedback set for 24-dB of IMP_3 and 10-dB of IMP_5 reduction.

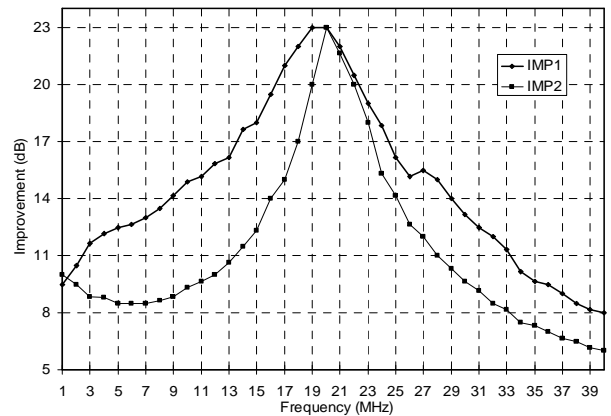

Fig. 5 Performance with changing frequency separation, when the feedback loop was initially set to operate at 20 MHz tone separation.

IV. FEEDBACK WITH DISTORTER II

The working principle and circuit structure is the same as the previous circuit; the difference is the new distorter used on the feedback loop. Through the experiments it has been observed that since there was no filtering applied to the distorter output, a low power level of third-harmonic zone signals were also being fed back to the input of the amplifier. This has limited the linearization bandwidth. This improved distorter

attenuates both fundamental and third-harmonic zones. The gain characteristic is shown in Fig. 6; note that the attenuation of the fundamental signals is not as high as the previous circuit, therefore an improvement in the linearization bandwidth is expected with a reduction in the amplifier gain. The two-tone test with and without feedback at 440 MHz with 1 MHz tone separation is shown in Fig. 7. The IMP_3 are reduced by 34-dB with 18-dB IMP_5 and complete suppression of IMP_7 to the noise level. As explained before, this is achieved along with a 1.5-dB reduction in the amplifier gain. In order to compensate for the power loss, the input power was increased by 1.5-dB and the net reduction in IMP_3 was then measured as 23-dB.

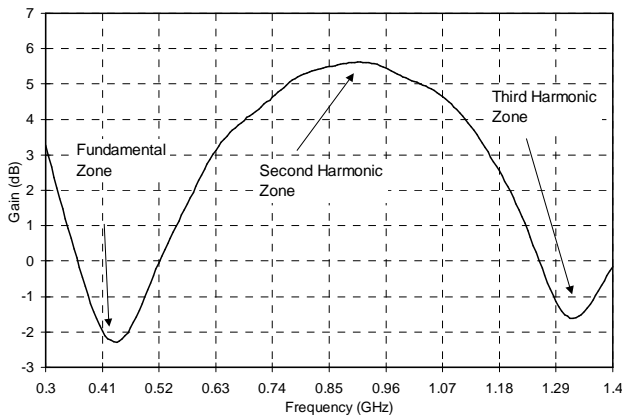

Fig. 6 Gain characteristics of the second distorter attenuating both fundamental and third harmonic zones.

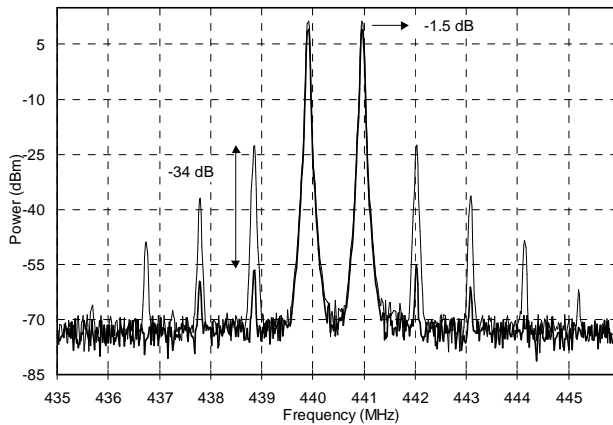

Fig. 7 Two-tone test with and without linearization technique applied.

In Fig. 8, the frequency separation has been swept from 100 kHz to 2 MHz when the circuit was initially set for 1 MHz tone separation. The degradation in the performance is gradual against the frequency changes. In Fig 9, the frequency separation has been increased up to 10 MHz from the 1 MHz initial point and IMP_3 reduction is observed. The degradation in the linearization performance is gradual even with this wide range of tone separation sweep. According to these results our technique is expected to perform both with a narrow and a wideband-modulated signal. In order to verify this practically, a TETRA $\pi/4$ DQPSK signal at 450 MHz is

used; Fig. 10 shows a 15-dB ACI reduction. The same prototype has shown 13-dB ACI reduction as shown in Fig. 11 with a W-CDMA signal having 5 MHz signal bandwidth at 450 MHz center frequency.

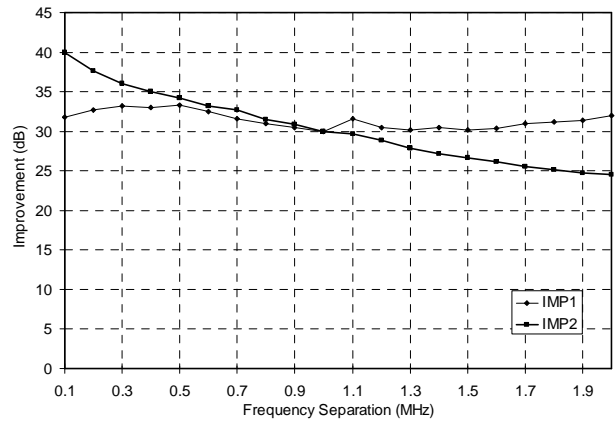

Fig. 8 Frequency separation sweep from 100 kHz to 2 MHz, when the feedback loop was initially set to operate at 1 MHz tone separation.

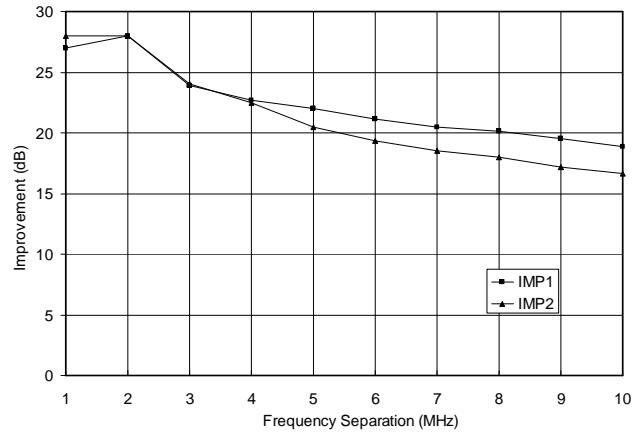

Fig. 9 Frequency separation increased up to 10 MHz, when the feedback loop was initially set to operate at 1 MHz tone separation.

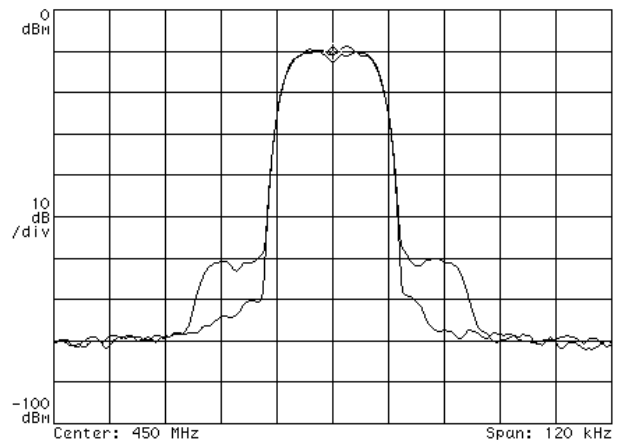

Fig. 10 Linearization performance with a TETRA $\pi/4$ DQPSK signal.

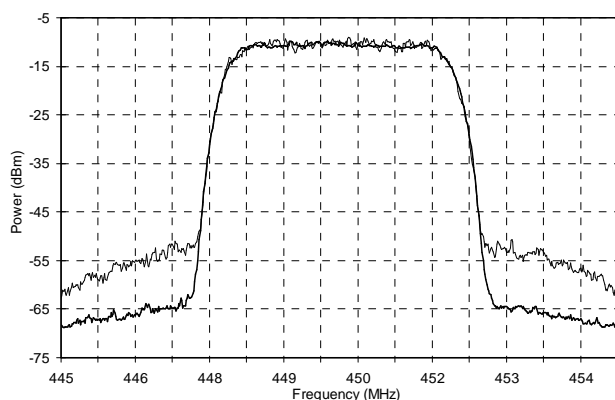

Fig. 11 Linearization performance with a W-CDMA having 5 MHz signal bandwidth.

V. CONCLUSION

In this paper, theoretical analysis and practical performance of a new active feedback technique have been presented. The results obtained from the two prototypes show that wideband IMD suppression can be achieved by using an active feedback approach to harmonic feedback. Up to 23-dB IMP_3 improvement was obtained at 440 MHz, with simple and low-cost circuitry. The same circuit showed promising performance by reducing ACI both with $\pi/4$ DQPSK and W-CDMA at 450 MHz. This is an important feature in base stations where several modulation formats are to be transmitted.

ACKNOWLEDGEMENTS

The authors would like to acknowledge the Center for Communications Research (CCR), University of Bristol for the provision of laboratory facilities and thank Lucent Technologies for their financial support.

REFERENCES

- [1] Daniel Myer, "Design of Linear Feedforward Amplifiers for PCN Systems", Design Feature, *Microwaves & RF*, pp. 121-133, September 1994.
- [2] P. Kenington, R. J. Wilkinson and J. Marvill, "Broadband Linear Amplifier Design for a PCN Base-Station", *Proc. of the 41st IEEE Conference on Veh. Technol.*, St. Louis, Missouri, May 1991, pp. 155-160.
- [3] A. K. Talwar, "Adaptive Feedforward Method and Apparatus for Amplifier Noise Reduction", U.S Patent No. 5,148,117, Sept. 15, 1992.
- [4] A. K. Talwar, "Reduction of Noise and Distortion in Amplifiers Using Adaptive Cancellation", *IEEE Transactions on Microwave Theory and Techniques*, Vol. 42, No. 6, June 1994, pp. 1086-87.
- [5] A. Bateman, R. J. Wilkinson, "Linearisation of Class C Amplifiers Using Cartesian Feedback". *IEEE Workshop In Mobile and Cordless Telephone Communications*, London, Sept. 1989, pp. 62-65.

- [6] M. Bolorian, J. P. McGeehan, "Maximization of the Cartesian Linearisation Bandwidth", *Electron. Lett.*, 1996, 32, (19), pp. 1823-1824.
- [7] M. Bolorian, J. P. McGeehan, "The Frequency Hopped Cartesian Feedback Linear Transmitter", *IEEE Trans. Veh. Technol.*, 1996, 45, (4), pp. 688-706.
- [8] J. K. Cavers, "Amplifier Linearisation using a Digital Predistorter with Fast Adaptation and Low Memory Requirements", *IEEE Trans. on Veh. Technol.*, Vol. VT-39, pp. 374-382, Nov. 1990.
- [9] M. Kumar, J. Whartenby and H. Wolkstein, "Predistortion Lineariser using GaAs Dual-Gate MESFET for TWTA and SSPA used in Satellite Transponders", *Vol. MTT-33*, December 1985, pp. 1479-1488.
- [10] M. Faulkner, T. Mattsson, and W. Yates, "Adaptive Linearisation using Predistortion", *Proc. 40th IEEE Vehicular Technol. conf.*, May 1990, pp. 35-40.
- [11] E. Ballesteros, F. Perez and J. Perez, "Analysis and Design of Microwave Linearized Amplifiers Using Active Feedback", *IEEE Transactions on Microwave Theory and Techniques*, Vol. 36, NO. 3, March 1988.
- [12] E. M. Cherry, D. E. Hooper, *Amplifying Devices and Low-Pass Amplifier Design*, John Wiley and Sons Inc., New York, 1968.
- [13] S. Rosenstark, *Feedback Amplifier Principles*, New York, Macmillan, 1986.
- [14] T. Nesimoglu, D. Budimir, R. M. Moazzam, and C. S. Aitchison, "Second Harmonic Injecting Technique for Low Intermodulation RF/Microwave Amplifiers", *Third IEEE High Frequency Colloquium*, 19 September 1997, University of Leeds, Leeds, UK.
- [15] M. R. Moazzam, C. S. Aitchison, "A Low Third Order Intermodulation Amplifier With Harmonic Feedback Circuitry", *IEEE MTT-S Digest*, June 1996, pp.827-830.
- [16] T. Nesimoglu, R. J. Wilkinson, C. N. Canagarajah and J. P. McGeehan, "Second Harmonic Zone Injection for Amplifier Linearization", *Proc. IEEE Veh. Technol. Conf., Houston*, May 1999, pp. 2353-2357.
- [17] J. Minkoff, "The Role of AM-to-PM Conversion In Memoryless Nonlinear Systems", *IEEE Trans. On Communications*, vol. COM-33, NO.2. pp. 139-144. February 1985.
- [18] M. Shetzen, "The Volterra and Weiner Theories of Nonlinear Systems", Wiley, New York, 1980.
- [19] S. Narayanan, "Application of Volterra Series to Intermodulation Distortion Analysis of Transistor Feedback Amplifiers", *IEEE Trans. on Circuit Theory*, Vol. CT-17, No.4, pp. 518-527, November 1970.