



Han, C., Zhu, X., Doufexi, A., & Koçak, T. (2012). Location-aided multi-user beamforming for 60 GHz WPAN systems. In IEEE 75th Vehicular Technology Conference (VTC2012-Spring), Yokohama, Japan. (pp. 1 - 5). Institute of Electrical and Electronics Engineers (IEEE).

[Link to publication record in Explore Bristol Research](#)
PDF-document

University of Bristol - Explore Bristol Research

General rights

This document is made available in accordance with publisher policies. Please cite only the published version using the reference above. Full terms of use are available:
<http://www.bristol.ac.uk/pure/about/ebr-terms.html>

Take down policy

Explore Bristol Research is a digital archive and the intention is that deposited content should not be removed. However, if you believe that this version of the work breaches copyright law please contact open-access@bristol.ac.uk and include the following information in your message:

- Your contact details
- Bibliographic details for the item, including a URL
- An outline of the nature of the complaint

On receipt of your message the Open Access Team will immediately investigate your claim, make an initial judgement of the validity of the claim and, where appropriate, withdraw the item in question from public view.

Location-aided Multi-user Beamforming for 60 GHz WPAN Systems

Congzheng Han^{*}, Xiaoyi Zhu^{*}, Angela Doufexi^{*}, and Taskin Kocak[†]

^{*}Department of Electrical and Electronic Engineering
University of Bristol, Bristol, United Kingdom
{Bernice.Han, X.Zhu, A.Doufexi}@bristol.ac.uk

[†]Department of Computer Engineering
Bahcesehir University, Istanbul, Turkey
Taskin.Kocak@bahcesehir.edu.tr

Abstract— 60 GHz wireless personal area networks (WPANs) offer multi-Gbps throughput, which will provide for a new wave of high data rate applications. This paper exploits the use of location information to improve the performance and enhance range of 60 GHz multi-user beamforming systems. When the location information is available at the transmitter, the scheduler chooses a set of maximum angularly separated users to share wireless resources simultaneously. If additional feedback of signal-to-interference and noise ratio (SINR) is known, a location-assisted scheduler is employed to increase the system overall performance. Both numerical and simulated results show that significant enhancement can be achieved by the proposed schedulers for 60 GHz WPAN systems.

Keywords- WPAN; 60 GHz; Scheduling; Beamforming; Location-aided communication

I. INTRODUCTION

In recent years, there has been growing interest in the 60 GHz millimeter-wave (mmWave) band to deliver multi-Gbps wireless multimedia services, such as uncompressed video transfer and fast synchronization of large files. The motivation has mobilized the effort of several international standardization groups to accommodate the characteristics of the mmWave. Among others, the IEEE 802.11ad [1] builds on the already existing strong market presence of Wi-Fi network in the 2.4/5 GHz bands. Because of the high attenuation and multi-path effects, communicating over 60 GHz channels is very challenging. Such systems require beamforming or other spatial diversity techniques to provide high gain to compensate for the large free space propagation loss.

In order to enhance the performance of the physical layer of the communication system, we assume that the indoor absolute location information of the devices is available at the transmitter (for example obtained by an ultra-wideband (UWB) system or other localization systems) [2]. Such a system provides information about the physical environment around the wireless communication devices, and allows storage of relevant quality information associated with time and location. This information can be exploited to develop new wireless physical layer capabilities.

With the availability of the current positioning information of the wireless devices in a beamforming system, optimum weights can be calculated and applied to the transmit signal to adjust the magnitude and phase of the signal to direct energy

towards or away from specific devices. Employing multiple antenna elements in an array improves the antenna gain and allows multiple beams to be formed to support multiple spatially-separable wireless terminals simultaneously [3]. Conventionally, beamforming systems generally require additional bandwidth due to feedback overhead and processing time to obtain the relative positions / angle-of-departure (AoD) of the wireless devices in the environment [4].

This paper exploits the location information and considers two low-feedback scheduling strategies for multiple access in a beamforming system. A multi-user scheduling algorithm that exploits spatial multi-user diversity based on only the location information is considered. The signal-to-interference and noise ratio (SINR) indicates the channel quality of a wireless terminal in the presence of interferences from other wireless terminals operating simultaneously. If SINR information is also available at the transmitter, a location-assisted sub-optimal scheduler is also considered to search for the group of wireless devices achieving the near-optimal overall data rate when transmitting simultaneously.

The rest of this paper is organized as follows. The physical layer (PHY), medium access control layer (MAC) and channel models of IEEE 802.11ad WPANs are presented in Section II. The orthogonal frequency division multiplexing (OFDM) based single-user and multi-user beamforming models are described in Section III. In Section IV, the location based scheduler algorithms are presented. The numerical analysis and simulation results based on our IEEE 802.11ad PHY simulator are shown in Section V. Section VI concludes the paper.

II. WPAN SYSTEM AND CHANNEL MODELLING

A. WPAN Network Architecture

In IEEE 802.11ad, the large spectrum around 60 GHz is equally divided into four channels. The OFDM and single carrier (SC) transmission techniques are specified. In this study, an OFDM system is considered in order to combat frequency selective fading and deliver high performance applications. A WPAN piconet is assumed to be consisted of M independent devices (DEVs), and one of them is selected as the piconet coordinator (PNC) that schedules peer-to-peer communications with other DEVs. The PNC manages the shared resource according to the requests from other DEVs in the piconet.

B. WPAN MAC Protocol

The time in the WPAN piconet is divided into consecutive superframes (SFs) consisting of a beacon period (BP), a contention access period (CAP) and a channel time allocation period (CTAP) [5]. The BP is used for periodically broadcasting a signal that indicates the beginning of each SF and sends management information. The CAP is based on carrier sense multiple access/collision avoidance (CSMA/CA) access, and is commonly used for burst traffic to guarantee high quality of service (QoS). The CTAP works in a time division multiple access (TDMA) manner, and is commonly used for time-sensitive communications such as high definition video streaming.

C. WPAN Channel Models

Based on the clustering phenomenon in both the temporal and spatial domains, a statistic channel model from a combination of measurements and ray-tracing was proposed for the 60 GHz WPANs. The considered system is evaluated in a conference room scenario in line-of-sight (LOS) condition. All the analysis assumes that the PNC and DEVs are in the same environment.

The large scale path loss (PL) for WPANs can be modeled as [6]:

$$PL(\text{dB}) = 32.5 + 20\log_{10}(f) + 20\log_{10}(D) \quad (1)$$

where f is the carrier frequency in GHz, and D is the distance between the PNC and DEV in meter.

III. SINGLE AND MULTI-USER BEAMFORMING

A. Beamforming for Single-user Transmission

We assume that the PNC is equipped with a uniform linear array (ULA) consisting of N_T antenna elements with a spacing of half wavelength λ . There are K wireless DEVs, each with a single receive antenna. We assume that all the array elements are noiseless isotropic antennas which have uniform gain in all directions. Let $X_{k,m}$ be the matching unit-power data symbol for the m th subcarrier of DEV k , and $N_{k,m}$ be the Gaussian noise with zero mean and variance of $\sigma_{k,m}^2$. The received vector signal at wireless DEV k is:

$$Y_{k,m} = \tilde{H}_{k,m} X_{k,m} + N_{k,m}, \quad m = 1, \dots, N \quad (2)$$

where N is the number of subcarriers, $\tilde{H}_{k,m}$ is the frequency response of the equivalent channel matrix after beamforming, which is given by:

$$\tilde{H}_{k,m} = c_{k,m}^H H_{k,m} w_{k,m}, \quad m = 1, \dots, N \quad (3)$$

where $[\cdot]^H$ is the Hermitian function, $H_{k,m}$ is the $1 \times N_T$ matrix containing user k 's frequency response of the channel at subcarrier m , w and c are the transmitter and the receiver beam steering vectors respectively. It is assumed that the total transmitted power of all antenna elements is normalized to 1. Then we have $w^H w = N_T$ and $c^H c = 1$.

The aim of beamforming is to choose the optimal transmit and receive weight vectors according to a selected criterion. In this work, the effective signal-to-noise ratio (SNR) is chosen as that criterion. The effective SNR defined as the average SNR across all subcarriers can be computed as [7]:

$$SNR_{k,eff} = -\beta \ln \left(\frac{1}{N} \sum_{m=1}^N \exp(-SNR_{k,m} / \beta) \right) \quad (4)$$

where $SNR_{k,m}$ is the symbol SNR experienced on the m th subcarrier, β is a parameter dependent on the coding rate, the modulation and the information block size. The SNR of the m th subcarrier can be calculated as [8]:

$$SNR_{k,m} = \frac{E \left[\left| c_{k,m}^H H_{k,m} w_{k,m} X_{k,m} \right|^2 \right]}{E \left[\left| N_{k,m} \right|^2 \right]} = \frac{\left| c_{k,m}^H H_{k,m} w_{k,m} \right|^2}{N_T \sigma_{k,m}^2} \quad (5)$$

In this work, we consider the optimal subcarrier-wise beamforming, which maximizes the average received SNR on each subcarrier as shown in Fig. 1.

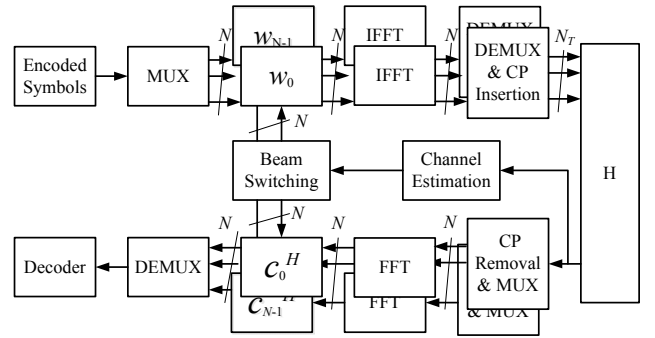

Figure 1: Block Diagram of Subcarrier-wise Beamforming

The optimum subcarrier-wise beamforming assumes that the beam steering vector w and c are adjusted based on a given optimality criterion. Under the effective SNR criterion, the problem for subcarrier-wise beamforming can be represented as:

$$SNR_{k,eff} = -\beta \ln \left(\frac{1}{N} \sum_{m=1}^N \exp \left(- \frac{\max_{c,w} \left| c_{k,m}^H H_{k,m} w_{k,m} \right|^2}{\beta N_T \sigma_{k,m}^2} \right) \right) \quad (6)$$

The numerical rate of a single user beamforming scheme without inter-user interference at subcarrier m is given by:

$$R_{k,m} = \log_2 \left(1 + SNR \left| c_{k,m}^H H_{k,m} w_{k,m} \right|^2 \right) \text{ bits/s/Hz} \quad (7)$$

B. Beamforming for Multi-user Transmission

Beamforming can also spatially separate signals, allowing different DEVs to share the same spectral resources realizing space division multiple access (SDMA), provided that they are spatially separable at the PNC. The location information of different DEVs can be used for designing the beamforming vectors. Assuming that the PNC simultaneously transmits to a

sub-set of DEVs A_c , the PNC transmits the superimposed signal of A DEVs from an array of N_T elements ($A \leq N_T$), and assuming the perfect channel information is available at the DEV, the SINR for each DEV can be calculated as:

$$SINR_{k,m} = \frac{P_k |c_{k,m}^H H_{k,m} w_{k,m}|^2}{\sum_{j \neq k} P_j |c_{j,m}^H H_{k,m} w_{j,m}|^2 + \sigma_{k,m}^2} \quad (8)$$

where P_k and $\sigma_{k,m}^2$ represent the signal and noise power of DEV k respectively, P_j is the signal power of other DEVs.

IV. LOCATION-AIDED MULTI-USER SCHEDULER

A. Location-Based Scheduler for Multi-user Beamforming

If location information is available at the PNC, a low-complexity location-based multi-user beamforming scheduler can be employed that aims to select a sub-set of DEVs that have a large inter-DEV angular separation in azimuth. The scheduler initially selects a targeted DEV in a round-robin fashion, and then selects up to $N_T - 1$ DEVs which are angularly far away from each other for transmission. Note that the performance of this algorithm depends on the exploitation of multi-user diversity and therefore it requires sufficient number of DEVs to be available in the environment.

B. Location-Assisted SINR-based Scheduler for Multi-user Beamforming

With the knowledge of location and channel information (SINR), an optimal scheduler will require to search through all possible sub-sets of terminals and find the one achieving the highest possible overall rate. Here a low-complexity and sub-optimal rate greedy scheduling approach for beamforming is considered. Let A_c denote an arbitrary sub-set of DEVs. The flow chart of the scheduler is illustrated in Fig. 2. At the beginning of the scheduling process, the targeted DEV is chosen in a round-robin fashion. Then at each step, a DEV that maximizes the overall rate R_c^{BF} is added to the chosen DEV subset. The scheduling process ends if none of the remaining DEVs can further increase the overall rate, i.e. the multi-user interference caused by adding a further DEV negatively affects the overall rate performance. Note \setminus denotes set-subtraction.

V. PERFORMANCE EVALUATION

A. System Configurations

The piconet is assumed to consist of $K = 10$ DEVs, and in the same time slot, two of the DEVs are activated to share the wireless resources with the PNC. Assuming the 3-dimensional coordinates of the DEVs are known at the PNC. Regarding the system parameters, a 60 GHz carrier frequency and half wavelength antenna spacing in a one-dimensional array are assumed. The key parameters used for the simulation of the WPAN system in this paper are shown in Table I. In this work, two different scenarios are considered:

1) Scenario 1

All DEVs are placed at equal distances from the PNC. They are randomly distributed and experience the same received

SINR at 0dB.

2) Scenario 2

All DEVs experience different received SINRs, based on their relative locations from the PNC within 10-meter radius coverage as shown in Fig. 3. For the location-assisted SINR-based scheduler, when the target user is selected, the PNC will compare the SINR from each sector using the location information, and maximize the overall system performance. On the other hand, for the location-based scheduler, once a target user is selected, the PNC will find the maximum angular separated DEV to transmit data simultaneously. However, in the latter case, the overall system performance may be degraded because the PNC does not consider the system overall performance.

The multi-user scheduling algorithms proposed in the previous section are initially examined in Scenario 1, and for DEVs experiencing independent channel conditions and received SINRs, the performance is investigated in Scenario 2.

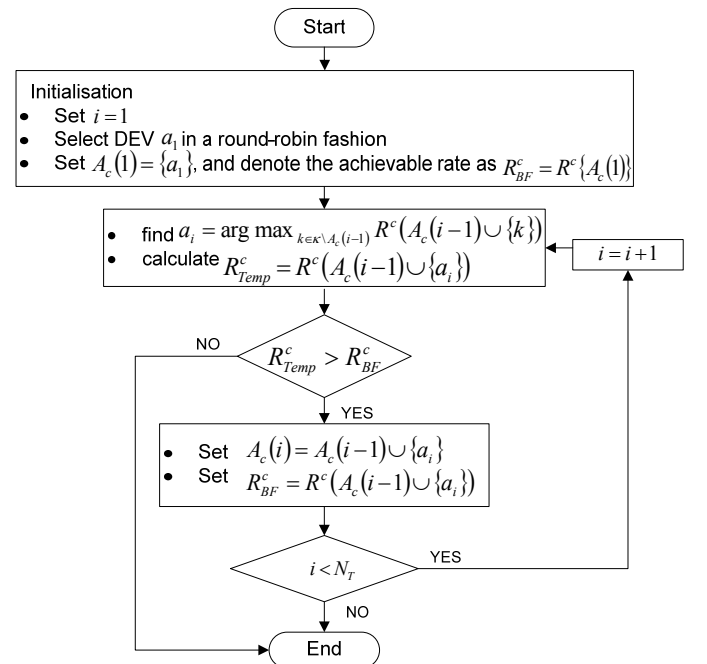

Figure 2: Flowchart for the Location-assisted SINR-based Scheduler

TABLE I. PARAMETERS FOR OFDM SYSTEMS IN IEEE 802.11AD

Parameter	Value
Transmission Bandwidth (MHz)	2160
Number of Subcarriers	512
Number of Data Subcarriers	336
Number of Pilot Subcarriers	16
Guard Interval Length	128
Sample Duration (ns)	0.38
OFDM Symbol Duration (ns)	242
Number of Users	10
Transmitter Power (dBm)	10
Receiver Noise Figure (dBm)	-63

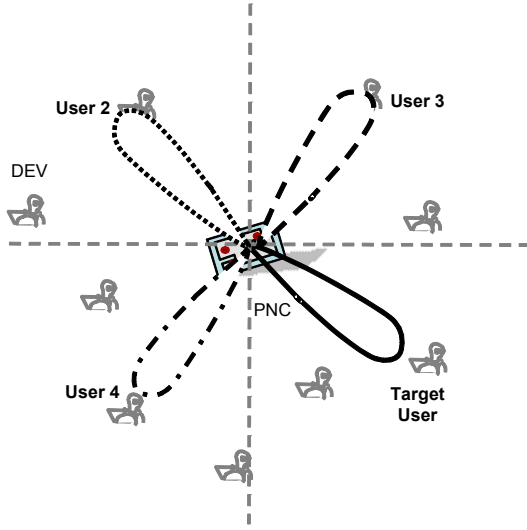

Figure 3: An Example of the Location-based Multiuser Scheduler

B. Numerical Analysis

In addition to capacity, in order to measure how fairly the available resources are shared among the DEVs, at any time slot t , the Jain's fairness index (JFI) [9] is investigated:

$$JFI(t) = \frac{\left(\sum_{k=1}^K R_k(t)\right)^2}{K \sum_{k=1}^K R_k^2(t)} \quad (9)$$

where R_k is the rate achieved by DEV k , and $0 < JFI < 1$ where a larger JFI value indicates better system fairness.

For the Scenario 1 and 2 respectively, Fig. 4 and Fig. 5 show the numerical spectral efficiency as a function of the number of the PNC transmit antennas $N_T = 2, 4, 6,$ and 8 . The spectral efficiency for a single-user single antenna system is also plotted for reference. It can be seen that the spectral efficiency increases with the increasing number of antennas. However, the growth of location-aided schemes is higher than single-user beamforming. This is due to the spatial reuse in the piconet. The space time division multiple access (STDMA) approach would introduce inter-user interference but also increase the spectral efficiency significantly. The results also show that the location-assisted SINR-based algorithm exploits resources even more efficiency than location-based beamforming for all antenna array sizes. It is worth mentioning that the spectral efficiency results are highly dependent on the relevant DEVs' locations.

Fig. 6 and Fig. 7 illustrate the cumulative distribution function (CDF) of the JFI for different number of users in Scenario 1 and 2 respectively. It is shown that the fairness performance improves as more DEVs are scheduled for transmission simultaneously. Given the same number of antenna array at the PNC, the location-assisted SINR-based scheme improves the fairness compared to the location-based scheme. The reason is that the location-based scheme is greedier, and the scheduling is based on the geometry information only. In Scenario 2, the fairness performance for larger number of users degrades compared to Scenario 1. This is because the PNC-DEV link distances are averaged and therefore the scheduler allocates resources to the DEVs which

are generally closer to the PNC and have better channel conditions.

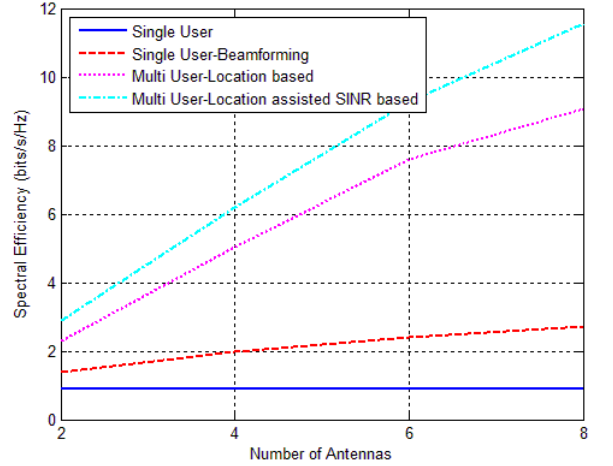

Figure 4: Numerical Spectral Efficiency for Different Schemes in Scenario 1

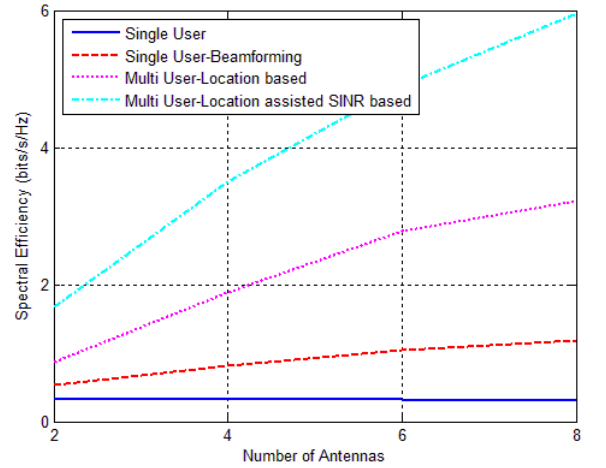

Figure 5: Numerical Spectral Efficiency for Different Schemes in Scenario 2

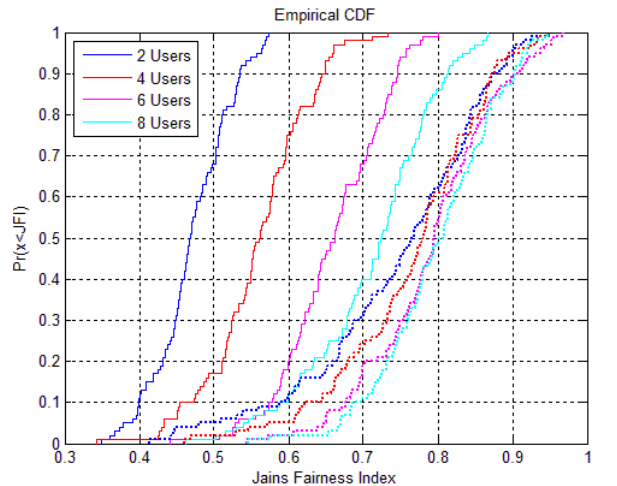

Figure 6: CDF of JFI for Different Number of Users in Scenario 1: Solid Lines-Location Based; Dotted Lines-Location Assisted SINR Based

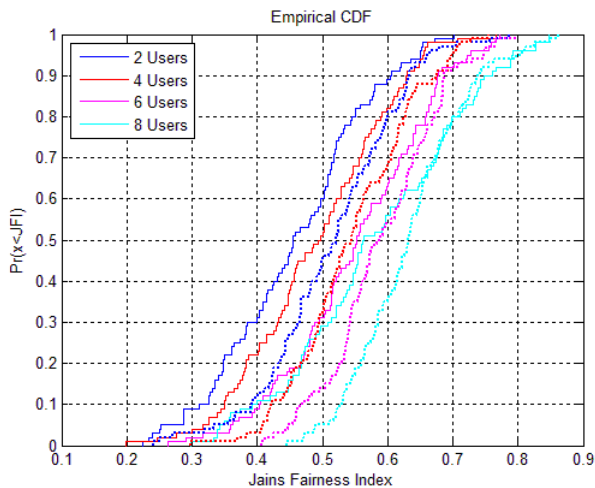

Figure 7: CDF of JFI for Different Number of Users in Scenario 2: Solid Lines-Location Based; Dotted Lines-Location Assisted SINR Based

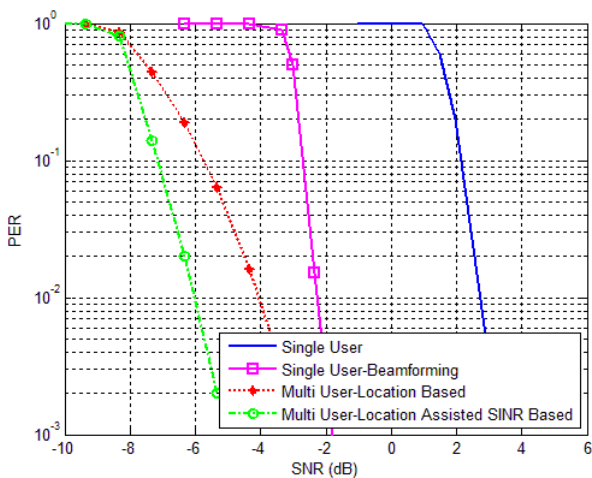

Figure 8: PER Performance of Different Schemes for QPSK 1/2 in Scenario 2

C. Link Level Simulation Results

In this section, the packet error rate (PER) performance of single-user beamforming and multi-user beamforming schemes we described in the previous sections are presented using our IEEE 802.11ad PHY MATLAB simulator. Assuming the number of antenna at the PNC is $N_T = 2$, two active DEVs are allowed to communicate with the PNC simultaneously. For the channel coding, LDPC (672, 336) encoder is implemented and the modulation scheme is QPSK. The exponential effective SNR parameter β equals 2, which is a typical value for QPSK modulation.

Fig. 8 compares the PER performance for the 60 GHz LOS channel. The single user system performance is also plotted for reference. The simulation results show that the subcarrier-wise beamforming increases the performance dramatically compared to the single antenna system. In order to achieve the PER target at 10^{-2} , the single antenna system needs about 5 dB more gain than two-antenna beamforming system. It is also shown that the pre-knowledge of location information at the PNC improved the overall system performance. The location-

assisted SINR-based approach has even better performance since the links with maximum overall rate are selected by the scheduler. This also means the multi-user interference is reduced.

VI. CONCLUSIONS

This paper has investigated the performance of a location information aided multi-user beamforming system. The analysis was performed for 60 GHz WPAN systems, and both numerical and simulation performances were presented. The detailed single-user and multi-user subcarrier-wise beamforming models were discussed. A low-complexity location information based scheduler aims to select a set of DEVs to communicate simultaneously which causes reduced inter-user interference. An optimal multi-user scheduling strategy based on SINR and assisted by location information has been proposed, and this strategy minimizes the interference and therefore achieve better system throughput. The numerical results show that considerable spectral efficiency and fairness can be achieved using the proposed schedulers. To verify the performance, the PER performance has been simulated with a 60 GHz channel model. The results show that location aided beamforming increases the 60 GHz WPAN systems performance significantly.

ACKNOWLEDGMENT

The authors would like to express their sincere appreciation to Blu-Wireless Technology for technical input, and also want to acknowledge the financial support provided by ClearSpeed Technology Ltd and Great Western Research (GWR).

REFERENCES

- [1] IEEE 802.11 Task Group AD, "PHY/MAC Complete Proposal Specification", IEEE 802.11-10/0433r2, May 2010.
- [2] R. Raulefs, S. Plass, C. Mensing, "The WHERE project – Combining Wireless Communications and Navigation," *20th Wireless World Research Forum (WWRF)*, April 2008, Ottawa, Canada.
- [3] J. C. Liberti, Jr., and T. S. Rappaport, *Smart Antennas for Wireless Communications: IS-95 and Third Generation CDMA Applications*, Prentice Hall 1999.
- [4] G. S. Dahman, R. H. M. Hafez, "Angle-of-Departure-Aided Opportunistic Space-Division Multiple Access", 7th Annual Communication Networks and Services Research Conference, May 2009.
- [5] C. Cordeiro, "Evaluation of Medium Access Technologies for Next Generation Millimeter-Wave WLAN and WPAN", *IEEE International Conference on Communications Workshops*, June 2009, Dresden, Germany.
- [6] A. Maltsev, V. Erceg, E. Perahia, *et al.*, "Channel Models for 60 GHz WLAN Systems", IEEE 802.11-09-0334-08-00ad, May 2010.
- [7] Y. Blankenship, P. Sartori, B. Classon, and K. Baum, "Link Error Prediction Methods for Multicarrier Systems", *IEEE 60th Vehicular Technology Conference*, September 2004, Los Angeles, USA.
- [8] S. Yoon, T. Jeon and W. Lee, "Hybrid Beam-forming and Beam-switch for OFDM Based Wireless Personal Area Network", *IEEE Journal on Selected Areas in Communications*, Vol. 27, Issue 8, pp. 1425-1432, October 2009.
- [9] R. Jain, D. Chiu and W. Hawe, "A Quantitative Measure of Fairness and Discrimination for Resource Allocation in Shared Computer Systems", *DEC Research Report TR-301*, Digital Equipment Corporation, September 1984.