



Huang, G., Nix, A. R., & Armour, S. M. D. (2009). Feedback reliability calculation for an iterative block decision feedback equalizer. In IEEE 70th Vehicular Technology Conference Fall 2009 (VTC 2009-Fall), Anchorage, USA. (pp. 1 - 5). Institute of Electrical and Electronics Engineers (IEEE). 10.1109/VETEFCF.2009.5378682

Link to published version (if available):
[10.1109/VETEFCF.2009.5378682](https://doi.org/10.1109/VETEFCF.2009.5378682)

[Link to publication record in Explore Bristol Research](#)
PDF-document

University of Bristol - Explore Bristol Research

General rights

This document is made available in accordance with publisher policies. Please cite only the published version using the reference above. Full terms of use are available:
<http://www.bristol.ac.uk/pure/about/ebr-terms.html>

Take down policy

Explore Bristol Research is a digital archive and the intention is that deposited content should not be removed. However, if you believe that this version of the work breaches copyright law please contact open-access@bristol.ac.uk and include the following information in your message:

- Your contact details
- Bibliographic details for the item, including a URL
- An outline of the nature of the complaint

On receipt of your message the Open Access Team will immediately investigate your claim, make an initial judgement of the validity of the claim and, where appropriate, withdraw the item in question from public view.

Feedback Reliability Calculation for an Iterative Block Decision Feedback Equalizer

Gillian Huang, Andrew Nix and Simon Armour

Centre for Communications Research, University of Bristol
Merchant Venturers Building, Woodland Road, Bristol BS8 1UB, UK
Email: {G.Huang, Andy.Nix, Simon.Armour}@bristol.ac.uk

Abstract—A new class of iterative block decision feedback equalizer (IB-DFE) was pioneered by Chan and Benvenuto. Unlike the conventional DFE, the IB-DFE is optimized according to the reliability of the feedback (FB) symbols. Since the use of the training sequence (TS) for feedback reliability (FBR) estimation lowers the bandwidth efficiency, FBR estimation without the need for additional TS is of considerable interest. However, prior FBR estimation is limited in the literature to uncoded M-ary phase-shift keying (PSK). In this paper we investigate FBR calculation methods for uncoded and coded M-ary quadrature amplitude modulation (QAM) systems. Results show that our newly proposed method has similar or better error rate performance than the TS method without the associated loss of bandwidth efficiency.

I. INTRODUCTION

Broadband single-carrier (SC) systems such as single-carrier frequency-domain equalization (SC-FDE) [1] and single-carrier frequency division multiple access (SC-FDMA) [2] have attracted significant research interest in recent years. SC systems have an inherent low peak-to-average power ratio (PAPR) property and this makes them better candidates compared to multicarrier systems for mobile uplink transmissions. For this reason, SC-FDMA is currently used on the uplink in the 3GPP LTE standard, while orthogonal frequency division multiple access (OFDMA) is used on the downlink [3]. Frequency-domain (FD) linear equalizers (LE) are commonly used in SC-FDE and SC-FDMA systems. However LE does not yield the best performance for SC systems due to the residual intersymbol interference (ISI) [8].

Hybrid decision feedback equalizers (H-DFE) that consist of a FD feedforward (FF) filter and a time-domain (TD) feedback (FB) filter were proposed in [1] and [4] for SC-FDE. The H-DFE has lower complexity than a conventional TD-DFE due to the FD-FF filter. Since the design of the H-DFE is based on the assumption that postcursor-ISI can be completely removed (i.e. all the FB symbols are correct), the H-DFE achieves its optimal performance in a reference-directed mode. However, the decision-directed H-DFE is liable to error propagation and this results in degraded performance relative to LE when channel coding is applied [5].

The concept of an iterative block DFE (IB-DFE) was first introduced in [6]. Compared to a conventional TD-DFE, the IB-DFE has two distinct properties: (1) an iterative block operation allows all the detected symbols from the previous iteration to be used as FB symbols in the current iteration. Hence both pre- and post-cursor ISI can be cancelled via the

FB process. (2) The design of the IB-DFE is optimized at each iteration according to the reliability of the FB symbols. Hence, it is robust against error propagation and better performance is achieved with increasing iteration number.

In contrast to the TD-based IB-DFE [6], the FD-based IB-DFE in [7] implements its FF and FB filters in the FD. This gives a very computationally efficient solution. Furthermore the FD-based IB-DFE has lower complexity than the H-DFE due to the FD-FB filter and a simpler approach to coefficient calculation (i.e. no matrix inversion is required for IB-DFE). The soft-decision IB-DFE is also proposed in [7]. Due to the high complexity of obtaining soft-decision FB symbols (especially in a coded system), this paper focuses on feedback reliability (FBR) calculation for the hard-decision IB-DFE. In the remainder of this paper IB-DFE is used to refer to the FD-based hard-decision IB-DFE.

As mentioned earlier, FBR is key to optimizing the performance of IB-DFE. Although a training sequence (TS) can be sent for the purposes of FBR estimation, this lowers the bandwidth efficiency. Hence estimating the FBR without the use of TS is of research interest. In [6], the approximated FBR calculation is given for uncoded M-ary phase-shift keying (PSK) via a symbol error probability. In [7], the FBR estimate is obtained by taking the channel response into account. However this approach is specifically for the uncoded QPSK case and may not be applicable to other modulation and coding schemes. To the authors' best knowledge, in the literature the results on IB-DFE are limited to uncoded QPSK due to the lack of FBR estimation. In this paper we investigate the FBR calculation and extend the performance evaluation of IB-DFE to M-ary quadrature amplitude modulation (QAM) for systems with and without coding.

The rest of this paper is organized as follows: Section II describes the IB-DFE operation. Section III investigates the FBR calculation methods for uncoded and coded M-ary QAM. The performance of the proposed IB-DFE scheme is compared with the TS method and the H-DFE in Section IV. Section V concludes the paper.

II. HARD-DECISION IB-DFE

For a cyclic prefix (CP) based SC-FDE system, the transmission block can be described as $x_n = [x_{-Q}, \dots, x_0, \dots, x_{P-1}]$, where Q denotes the length of the CP and P denotes the number of baseband symbols in one transmission block. Let

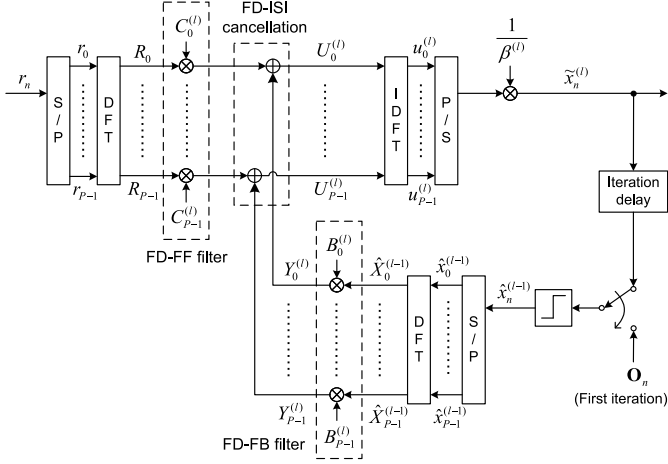

Fig. 1. SC-FDE receiver with IB-DFE

$\{h_k\}_{k=0,\dots,L}$ denote the channel impulse response (assuming the CP length is longer than the maximum channel delay spread, i.e. $Q > L + 1$) and w_n denotes the white Gaussian noise. The TD received signal can be described as

$$r_n = \sum_{k=0}^L h_k x_{n-k} + w_n. \quad (1)$$

For $n = 0, \dots, P - 1$, r_n denotes the received signal with the CP removed. The CP forces the linear convolution of the transmit signal and the channel impulse response to appear as a cyclic convolution at the receiver. Hence taking the discrete Fourier transform (DFT) of r_n the received FD signal R_p can be described as

$$R_p = \frac{1}{\sqrt{P}} \sum_{n=0}^{P-1} r_n e^{-j\frac{2\pi}{P}pn} = H_p X_p + W_p \quad (2)$$

where $p = 0, \dots, P - 1$. $H_p = \sum_{k=0}^L h_k e^{-j\frac{2\pi}{P}pk}$ denotes the channel frequency response. $X_p = \frac{1}{\sqrt{P}} \sum_{n=0}^{P-1} x_n e^{-j\frac{2\pi}{P}pn}$ denotes the FD transmit signal and $W_p = \frac{1}{\sqrt{P}} \sum_{n=0}^{P-1} w_n e^{-j\frac{2\pi}{P}pn}$ denotes the noise in the FD.

Fig. 1 shows a SC-FDE receiver with an IB-DFE, where the FF and FB filters are both implemented in the FD. The received TD signal $\{r_n\}$ is first converted to the FD, denoted as $\{R_p\}$. The received FD signal is filtered by the FD-FF filter $\{C_p^{(l)}\}$ where the superscript l denotes the l -th iteration of the IB-DFE process. ISI cancellation is then applied to this FF filtered signal. The FD-ISI estimate $\{Y_p^{(l)}\}$ is obtained from the multiplication of the FD-FB filter $\{B_p^{(l)}\}$ and the estimated FD signal $\{\hat{X}_p^{(l-1)}\}$ from the previous iteration. The FD-FB signal $\{\hat{X}_p^{(l-1)}\}$ comes from the hard detected TD signal $\{\hat{x}_n^{(l-1)}\}$ in the previous iteration. Finally the equalized FD signal $\{U_p^{(l)}\}$ is converted back to the TD, i.e. $\{u_n^{(l)}\}$.

The equalized TD signal $u_n^{(l)}$ is multiplied by $\frac{1}{\beta^{(l)}}$ to scale the TD signal to the desired signal amplitude for detection. $\beta^{(l)}$ is introduced since the FF filter power varies with FB reliability $\rho^{(l-1)}$. This will be seen later in the FF filter design.

Hence the output of the IB-DFE at the l -th iteration can be described as

$$\tilde{x}_n^{(l)} = \frac{1}{\beta^{(l)}\sqrt{P}} \sum_{p=0}^{P-1} \left(R_p C_p^{(l)} + B_p^{(l)} \hat{X}_p^{(l-1)} \right) e^{j\frac{2\pi}{P}pn}. \quad (3)$$

The IB-DFE is designed to minimize the MSE at the equalizer output according to the reliability of the FB symbols. Optimal FF and FB filter coefficients for the IB-DFE are derived in [7]. Hence only the results are given here. The FD-FF filter coefficients at the l -th iteration are defined as

$$C_p^{(l)} = \frac{H_p^*}{\sigma_w^2 + E_s \left(1 - (\rho^{(l-1)})^2 \right) |H_p|^2} \quad (4)$$

where $E_s = E[|x_n|^2]$ and $\sigma_w^2 = E[|w_n|^2]$ are the expected value of the transmit signal power and the noise power respectively. $\rho^{(l-1)}$ denotes the reliability of the FB symbols (i.e. FBR) and is defined as the expectation of the normalized correlation between the hard detected symbols at the previous iteration and the transmit symbols [6], i.e.

$$\rho^{(l-1)} = \frac{E \left[\hat{x}_n^{(l-1)} x_n^* \right]}{E_s}. \quad (5)$$

Note that the FBR in (5) results in a value between 0 and 1. The FD-FB filter coefficients at the l -th iteration are

$$B_p^{(l)} = -\rho^{(l-1)} \left[C_p^{(l)} H_p - \beta^{(l)} \right] \quad (6)$$

where $\beta^{(l)}$ denotes the average signal amplitude after FF filtering. This DC value has to be removed from the FB filter. $\beta^{(l)}$ can be calculated using

$$\beta^{(l)} = \frac{1}{P} \sum_{p=0}^{P-1} C_p^{(l)} H_p. \quad (7)$$

At the first iteration, no FB symbols are available so the FBR is set to zero, i.e. $\rho^{(0)} = 0$. In this case, the FF filter coincides with the minimum mean square error (MMSE) LE and the FB filter is turned off (see (4) and (6)). As the FBR increases, the FB filter tends to cancel more ISI. Therefore the performance improves with the number of iterations. When $\rho^{(l-1)} = 1$, the FF filter coincides with the matched filter and the FB filter aims to cancel all the ISI. Hence the ideal performance of IB-DFE (assuming all the FB symbols are error free and the FBR is 1) is the matched filter bound (MFB).

III. FEEDBACK RELIABILITY CALCULATION

When the TS method is used to estimate FBR, the TS must have the same modulation and coding scheme as the data sequence. This implies that the TS cannot be shared with the existing reference signals. Since the TS method lowers the bandwidth efficiency and achievable throughput, it is desirable to obtain an accurate FBR without the need for additional TS in order to optimize the performance of IB-DFE. However current FBR estimation is limited to uncoded M-ary PSK systems [6] [7]. In this section FBR calculation methods for uncoded and coded M-ary QAM systems are proposed.

In order to keep the FBR calculation simple and channel-independent, we propose to calculate the FBR from the signal-to-noise ratio (SNR) at the equalizer output. The SNR at the IB-DFE output can be estimated via

$$\text{SNR}^{(l-1)} = \frac{E_s}{\frac{1}{P} \sum_{n=0}^{P-1} |\hat{x}_n^{(l-1)} - \hat{x}_n^{(l-1)}|^2} \quad (8)$$

where $\hat{x}_n^{(l-1)}$ are the re-encoded symbols in the coded case.

The following FBR calculation methods are based on the assumption that the noise at the equalizer output (which is the sum of filtered noise and residual-ISI) is Gaussian distributed. It was verified by simulation that this equalized noise can be well-approximated by a Gaussian distribution. This occurs because the equalized noise is mainly dominated by the filtered noise (Note: filtered noise will still be Gaussian distributed even though it is coloured) and in a time-dispersive channel the residual-ISI can be approximated by a Gaussian distribution from the central-limit theorem.

A. Feedback Reliability Derivation for 4QAM

The hard-decision TD-FB symbols at the l -th iteration can be described as $\hat{x}_n^{(l-1)} = x_n + \hat{e}_n^{(l-1)}$, where $\hat{e}_n^{(l-1)}$ denotes the hard-decision error (Note: we will drop the l -th iteration at the superscript for the following derivation). Hence (5) can be rewritten as

$$\rho = 1 + \frac{E[\hat{e}_n x_n^*]}{E_s} \quad (9)$$

where $E[\hat{e}_n x_n^*]$ can be expressed as

$$E[\hat{e}_n x_n^*] = \sum_{i \in A} \sum_{k \in A, k \neq i} \hat{e}(i, k) x^*(i) p(\hat{e}(i, k), x^*(i)) \quad (10)$$

where A denotes a set of all possible transmit symbols in a baseband modulation scheme.

For 4QAM, all the transmit symbols have the same magnitude and the same symbol error probability (Note: this will not be the case for 16QAM). Hence (10) can be simplified to

$$E[\hat{e}_n x_n^*] = \sum_k \hat{e}(k) x^* p(\hat{e}(k)|x). \quad (11)$$

Fig. 2 shows the hard-decision error pattern for 4QAM. Let $\tilde{x} = s_1 + j s_2$ denote the soft symbols at the equalizer output, and $\gamma_s = E_s/N_0$ denote the equivalent SNR at the equalizer output. Hence the probability of receiving the symbols in the region of $k = 1$ when transmitting $x = \frac{1}{\sqrt{2}}(1 + j)$ is [8]

$$\begin{aligned} p(\hat{e}(k=1)|x) &= p(s_1 < 0, s_2 > 0) \\ &= Q(\sqrt{\gamma_s}) [1 - Q(\sqrt{\gamma_s})] \end{aligned} \quad (12)$$

where $Q(u) = \frac{1}{\sqrt{2\pi}} \int_u^\infty e^{-t^2/2} dt$. Likewise, the probabilities of receiving the symbols in the region of $k = 2$ and $k = 3$ are

$$p(\hat{e}(k=2)|x) = [1 - Q(\sqrt{\gamma_s})] Q(\sqrt{\gamma_s}) \quad (13)$$

$$p(\hat{e}(k=3)|x) = [Q(\sqrt{\gamma_s})]^2. \quad (14)$$

For $\hat{e}(k) x^*$, $\hat{e}(k=1) x^* = -1 + j$, $\hat{e}(k=2) x^* = -1 - j$ and $\hat{e}(k=3) x^* = -2$. Substituting the results of $\hat{e}(k) x^*$

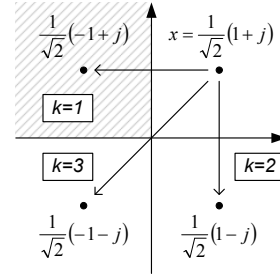

Fig. 2. Hard-decision error pattern for 4QAM

and (12)-(14) into (11), it can be shown that $E[\hat{e}_n x_n^*] = -2Q(\sqrt{\gamma_s})$. Hence the FBR for uncoded 4QAM is

$$\rho = 1 - 2Q(\sqrt{\gamma_s}). \quad (15)$$

B. Gaussian CDF Approximation for 16QAM

It is possible to derive the reliability for uncoded 16QAM using (10). However, the derivation process is very tedious and the final expression includes numerous terms. It is observed that the simulated reliability curves for uncoded 16QAM and 64QAM fit well to a Gaussian CDF model and this model also gives values between 0 and 1. Hence we propose to approximate the reliability as a function of SNR at the equalizer output using a Gaussian CDF model, i.e. [8]

$$\hat{\rho}_i = \frac{1}{2} + \frac{1}{2} \text{erf}(a\gamma_i + b) \quad (16)$$

where $\hat{\rho}_i$ is the approximated reliability and γ_i is the SNR value in dB. a and b are parameters to be determined.

Let ε_i denote the inaccuracy of the model; the true reliability ρ_i can be expressed as

$$\rho_i = \frac{1}{2} + \frac{1}{2} \text{erf}(a\gamma_i + b + \varepsilon_i). \quad (17)$$

Since the true reliability is unknown, the simulated reliability is used as ρ_i . Simulated reliability is an average reliability that is obtained via large numbers of simulations using an additive white Gaussian noise (AWGN) channel. Now the inverse error function can be utilized to convert the non-linear regression problem into a simple linear regression problem. Let z_i denote the inverse error function in (17) such that

$$z_i = \text{erf}^{-1}(2\rho_i - 1) = a\gamma_i + b + \varepsilon_i. \quad (18)$$

In (18), the optimum \hat{a} and \hat{b} values that minimize the sum of the square error of ε_i are [9]

$$\hat{a} = \frac{\frac{1}{N} \left(\sum_{i=0}^{N-1} \gamma_i z_i \right) - \frac{1}{N^2} \left(\sum_{i=0}^{N-1} \gamma_i \right) \left(\sum_{i=0}^{N-1} z_i \right)}{\frac{1}{N} \left(\sum_{i=0}^{N-1} \gamma_i^2 \right) - \frac{1}{N^2} \left(\sum_{i=0}^{N-1} \gamma_i \right)^2} \quad (19)$$

$$\hat{b} = \frac{1}{N} \left(\sum_{i=0}^{N-1} z_i \right) - \hat{a} \frac{1}{N} \left(\sum_{i=0}^{N-1} \gamma_i \right) \quad (20)$$

where N is the number of samples used in the regression.

Fig. 3(a) shows the linear regression graph of z_i vs. γ_i for 16QAM, where $\hat{a} = 0.0750$ and $\hat{b} = 0.4098$. The regression

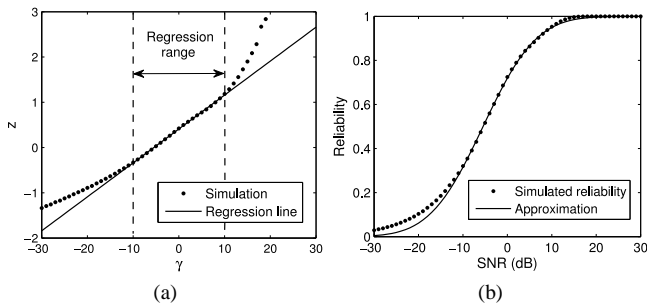

Fig. 3. Uncoded 16QAM: (a) Linear Regression. (b) Gaussian CDF approximation vs. simulated reliability.

is performed in the SNR range from -10dB to 10dB since the accuracy of low reliability at low SNR is not of interest and z_i goes to infinity at high SNR. Fig. 3(b) shows that the reliability for uncoded 16QAM is well-approximated using the Gaussian CDF model in (16) with the above \hat{a} and \hat{b} values. Note that for uncoded 64QAM the reliability curve can also be well-approximated via a Gaussian CDF model.

C. Lookup Table for IB-DFE with Channel Coding

When operating the IB-DFE in a coded system, it is recommended to decode the equalized symbols and use the re-encoded data to form the FB symbols with higher reliability [6]. However, there is no explicit method for deriving the reliability of the re-encoded symbols. In this paper, we propose to use a pre-defined lookup table for reliability mapping in the channel coding case. The reliability of the re-encoded FB symbols is a function of the coding (and decoding) and the modulation scheme. Fig. 5 shows the lookup graph for 4QAM and 16QAM. This graph maps the SNR at the equalizer output to the reliability of the re-encoded symbols. A 1/2-rate convolutional encoder (133,171) and a soft-decision Viterbi decoder are used in this example. Fig. 5 is obtained via a large number of simulations using an AWGN channel.

IV. RESULTS AND DISCUSSION

In the simulation it is assumed that the subcarrier spacing is 15kHz [3] and the number of subcarriers is $P = 512$. The CP length is set to $Q = 64$ which is longer than the maximum channel delay spread. Hence one SC-FDE block period is $T_{\text{BLK}} = \frac{(512+64)}{15\text{kHz} \times 512} = 75\mu\text{s}$. The urban macro scenario of the Spatial Channel Model Extended (SCME) [10] is used and ideal channel estimation is assumed. When channel coding is applied, a 1/2-rate convolutional encoder and a soft-decision Viterbi decoder are used with a block bit-interleaving scheme. The subframe structure in the LTE uplink [3] is adapted to calculate the bandwidth efficiency. Each subframe has six data blocks and two short blocks for reference signals. Assuming that one data block will be used as the TS in the TS method, the bandwidth efficiencies for the TS method and the proposed method are $\eta_{\text{BW}} = 5/7$ and $\eta_{\text{BW}} = 6/7$ respectively.

Fig. 5 shows the bit error rate (BER) comparison of uncoded 4QAM with IB-DFE using the TS method and the proposed

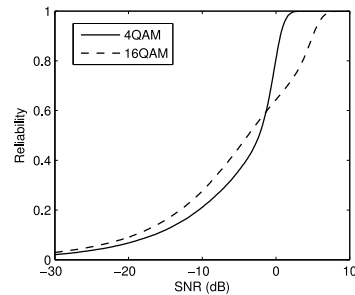

Fig. 4. Lookup table for reliability vs. SNR for 4QAM and 16QAM with 1/2-rate convolutional encoder (133,171) and soft-decision Viterbi decoder.

method. For clarification of the curves, the third iteration is not shown. It can be seen that the FBR calculation in (15) gives almost the same BER performance as the TS method. In this case the FBR calculation method is preferred since it offers better bandwidth efficiency. For IB-DFE, the second iteration gives a large gain over the first iteration (i.e. LE) and the gains of further iterations are reduced. This is because the performance of LE is limited by residual-ISI. The use of FB ISI cancellation in the second iteration is able to overcome this limitation considerably and hence achieves a large performance gain.

Fig. 6 shows the BER comparison for uncoded 16QAM. In this case the proposed method (see Fig. 3(b)) outperforms the TS method. Unlike 4QAM, 16QAM symbols do not have uniform reliability. FBR estimation from a TS composed of random 16QAM symbols can result in more FBR mismatch than the Gaussian CDF approximation based on average FBR. As a result, the proposed Gaussian CDF model outperforms the TS method for uncoded 16QAM.

Fig. 5 and Fig. 6 both show that the proposed IB-DFE scheme in the second iteration has similar performance as the decision-directed H-DFE for the uncoded case. While the complexity of H-DFE grows linearly with the TD-FB filter length (or the maximum channel delay spread), the IB-DFE requires only a one-tap per subcarrier FD-FB filter. Moreover the matrix inversion required as part of the H-DFE coefficient calculation [4] results in greatly increased complexity. Hence, notwithstanding the second iteration, the IB-DFE still has significantly lower complexity than the H-DFE.

Fig. 7 shows the block error rate (BLER) comparison of coded 16QAM. In this case the proposed lookup table approach (see Fig. 4) produces a BLER result that is close to the TS method. The proposed coded IB-DFE scheme shows superb performance. The second iteration gives a 2.5dB gain over the LE, and after the fourth iteration it performs within 1dB of the MFB at a BLER of 0.01. The H-DFE gives poor performance in a coded system due to error propagation as investigated in [5]. Fig. 8 shows the corresponding throughput comparison of coded 16QAM. The throughput is estimated as $\frac{(1-\text{BLER}) \times N_{\text{bits}}}{T_{\text{BLK}}} \times \eta_{\text{BW}}$, where N_{bits} is the number of information bits per block. For the same BLER, the proposed IB-DFE scheme shows significantly better throughput compared to the

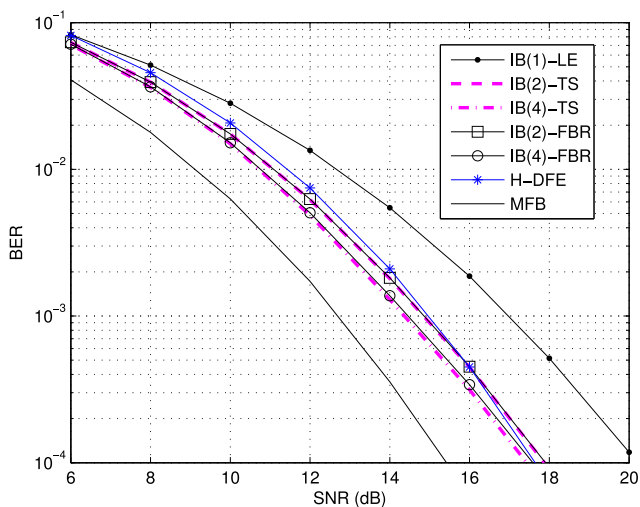

Fig. 5. BER of uncoded 4QAM with IB-DFE

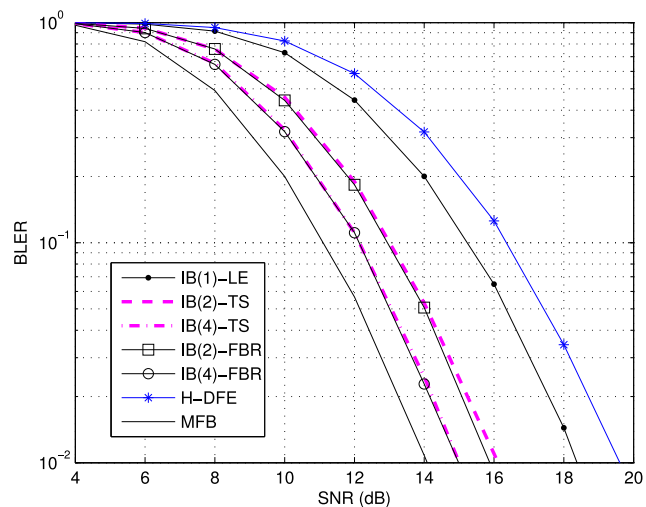

Fig. 7. BLER of coded 16QAM with IB-DFE

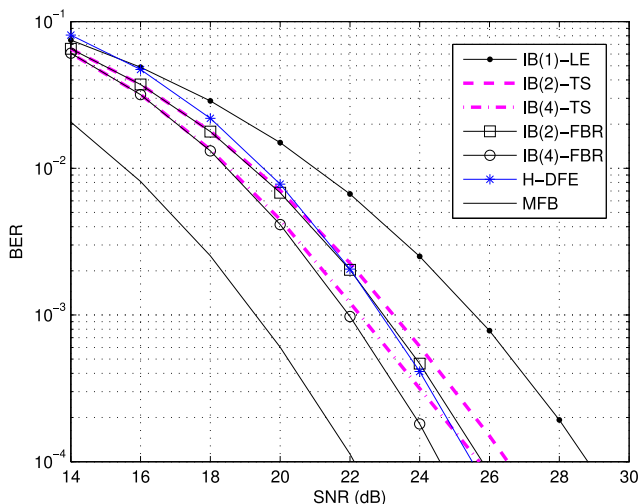

Fig. 6. BER of uncoded 16QAM with IB-DFE

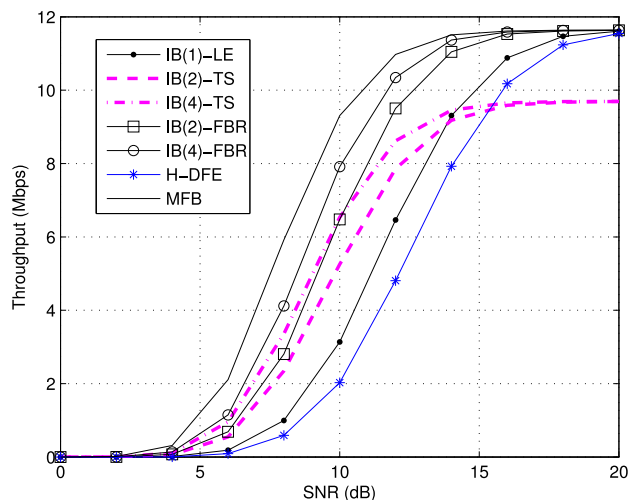

Fig. 8. Throughput of coded 16QAM with IB-DFE

TS method due to improved bandwidth efficiency.

V. CONCLUSIONS

The FBR calculation and the performance of IB-DFE was investigated for both uncoded and coded M -ary QAM. Results show that the proposed method gives similar or better error rate performance than the TS method without sacrificing bandwidth efficiency. The proposed IB-DFE scheme is also better than the H-DFE since it matches its performance (with lower complexity) in the uncoded case and provides a more consistent result in the coded case. Hence, by using our proposed FBR calculation method the IB-DFE becomes a very reliable and attractive equalization scheme for enhancing the performance of broadband SC systems such as SC-FDMA in the LTE uplink.

REFERENCES

[1] D. Falconer *et al.*, "Frequency domain equalization for single-carrier broadband wireless systems," *IEEE Commun. Mag.*, vol. 40, no. 4, pp. 58-66, Apr. 2002.

[2] H. Myung, J. Lim and D. Goodman, "Single carrier FDMA for uplink wireless transmission," *IEEE Vehicular Technology Mag.*, vol. 1, no. 6, pp. 30-38, Sept. 2006.

[3] 3GPP, "Physical layer aspects for evolved UTRA," TR 25.814 V7.1.0, Sept. 2006.

[4] N. Benvenuto and S. Tomasin, "On the comparison between OFDM and single-carrier modulation with a DFE using a frequency-domain feedforward filter," *IEEE Trans. Commun.*, vol. 50, no. 6, pp. 947-955, Jun. 2002.

[5] G. Huang, A. Nix and S. Armour, "Decision-feedback equalization in SC-FDMA," in *Proc. of PIMRC'08*, Sept. 2008.

[6] A. Chan and G. Wornell, "A class of block-iterative equalizers for intersymbol interference channels: fixed channel results," *IEEE Trans. Commun.*, vol. 49, no. 11, pp. 1966-1976, Nov. 2001.

[7] N. Benvenuto and S. Tomasin, "Iterative design and detection of a DFE in the Frequency Domain," *IEEE Trans. Commun.*, vol. 53, no. 11, pp. 1867-1875, Nov. 2005.

[8] J. G. Proakis, *Digital Communications*, 4th ed. New York: McGraw-Hill, 2001.

[9] G. James, *Advanced Modern Engineering Mathematics*, 2nd ed. Prentice Hall, 1999.

[10] D. Baum *et al.*, "An interim channel model for beyond-3G system: extending the 3GPP spatial channel model," in *Proc. VTC'04-Spring*, vol. 5, Stockholm, May 2005.