



Han, C., Doufexi, A., Armour, S. M. D., McGeehan, J. P., & Sun, Y. (2007). Random beamforming OFDMA for future generation cellular communication systems. IEEE 66th Vehicular Technology Conference, VTC-2007 Fall, 516 - 520. 10.1109/VETEFCF.2007.119

Link to published version (if available):
[10.1109/VETEFCF.2007.119](https://doi.org/10.1109/VETEFCF.2007.119)

[Link to publication record in Explore Bristol Research](#)
PDF-document

University of Bristol - Explore Bristol Research

General rights

This document is made available in accordance with publisher policies. Please cite only the published version using the reference above. Full terms of use are available:
<http://www.bristol.ac.uk/pure/about/ebr-terms.html>

Take down policy

Explore Bristol Research is a digital archive and the intention is that deposited content should not be removed. However, if you believe that this version of the work breaches copyright law please contact open-access@bristol.ac.uk and include the following information in your message:

- Your contact details
- Bibliographic details for the item, including a URL
- An outline of the nature of the complaint

On receipt of your message the Open Access Team will immediately investigate your claim, make an initial judgement of the validity of the claim and, where appropriate, withdraw the item in question from public view.

Random Beamforming OFDMA for Future Generation Cellular Communication Systems

Congzheng Han, Angela Doufexi, Simon Armour, Joe McGeehan
University of Bristol, Woodland Road, Bristol, BS8 1UB, U.K.
Email: Bernice.Han@bris.ac.uk

Yong Sun
Toshiba Research Laboratory
Queens Square, Bristol, BS1 4ND, U.K.

Abstract—This paper presents a downlink performance analysis of a Layered Random Beamforming (LRB) - MIMO-OFDMA Physical Layer (PHY) as applicable to future generation wireless communication systems. OFDMA is a popular multiple access candidate for future generation cellular communication systems which facilitates multi-user diversity by enabling multiple access in the frequency domain. Random Beamforming (RB) is a method which enables the exploitation of spatial multi-user diversity gain and a spatial multiplexing capacity gain. Unlike a conventional beamforming system, an RB system only requires effective signal to noise ratios (ESNR) as feedback and thus has potentially much lower feedback requirements than a system which requires feedback of more detailed channel information. The Layered method (LRB) enables the spatial multiplex of data transmitted simultaneously to different destinations. As a result it is able to offer a further spatial multi-user diversity gain, referred to here as layer multi-user diversity gain to distinguish from that achieved by the RB technique. An LRB-OFDMA system is thus able to achieve the rich benefits of spatial multiplexing capacity gain in combination with spatial, layer and spectral multi-user diversity gains. In this paper, the design of both RB-OFDMA and LRB-OFDMA systems are proposed and the performance of the system is evaluated by software simulation using various statistical channel models.

I. INTRODUCTION

Future generation cellular systems are expected to support multi-user transmission, provide higher data rates and spectral efficiency and enable improved coverage and communication reliability. Among all existing techniques, a MIMO-OFDMA system is one of the most promising PHY and multiple access candidates for future communication systems [1]. Long Term Evolution (LTE) of the Third Generation Partnership Project (3GPP) aims to improve the existing 3G standard to cope with future requirements and it has already assumed that the downlink of the air interface would be OFDMA based [2]. Compared to MIMO systems employing Space-Time Block Codes (STBCs) for diversity gain and Spatial Multiplexing (SM) for increased transmission rates, Eigenbeamforming [3,4] is a capacity achieving transmission scheme that utilises singular value decomposition (SVD) and requires full channel state information (CSI) at the transmitter. However, when the channel varies rapidly in time, frequency and/or space, full CSI requires a significant amount of feedback information and may thus be inefficient or impractical for real time applications.

In a system with many mobile stations, there is likely to be at least one mobile station (MS) whose channel is near a peak in quality at one time and/or frequency, provided different mobile stations experience independent fading channels. Application of a randomly generated beamforming pattern at the transmitter to achieve **Opportunistic Beamforming** is

proposed in [5]. Provided there are many independent mobile stations in the environment, it can effectively exploit multi-user diversity in combination with transmit beamforming to attain the coherent beamforming capacity and only requires the feedback of SNR information (no spatial information is required). [6] extends this theory to a MIMO system and develops the **Random Beamforming** (RB) technique which utilizes SVD and is capable of achieving spatial multi-user diversity gain and spatial multiplexing gain. A random beamforming system generates a random precoding matrix at the transmitter and selects the best mobile station based on effective SNR (ESNR) feedback indicating the channel quality from every mobile station. ESNR considers the eigenvalues of the MIMO channels and the mismatch between the random precoding matrix and the unitary matrix of the actual MIMO channels as will be presented below. A **Layered Random Beamforming** (LRB) technique is proposed in [7] which uses a linear receiver to separate the spatial layers in MIMO channels and allocate them to different mobile stations at the same time to achieve an additional 'layer' spatial multi-user diversity gain. For LRB, the ESNR feedback from every spatial layer of the MIMO channels of a mobile station indicates the spatial information and self-interference caused by the mismatch between the random precoding matrix and the unitary matrix of the actual channel. However, in all these papers, only the numerical throughput analysis of random beamforming techniques is presented and the focus is on single carrier systems.

In this paper, the designs of both the original and layered random beamforming OFDMA PHY are proposed and both numerical and simulation performances of RB and LRB-OFDMA are evaluated in different scenarios. Compared to single carrier systems, both RB and LRB-OFDMA systems are capable of achieving an additional spectral multi-user diversity gain in frequency selective channels. Compared to RB-OFDMA, LRB-OFDMA can effectively exploit a further layer spatial multi-user diversity gain and therefore offers a better data rate and error performance. Both RB-OFDM(A) and LRB-OFDM(A) in this paper employ an MMSE linear receiver. Both numerical and simulation based performance analysis of RB-OFDM, RB-OFDMA, LRB-OFDM and LRB-OFDMA are presented here.

This paper is organized as follows. Section II describes the PHY model of the random beamforming OFDMA system. In Section III, the performance of LRB-OFDMA is compared with RB-OFDM, RB-OFDMA and LRB-OFDM using both numerical and simulation results in various statistical channel models. Section V concludes the paper.

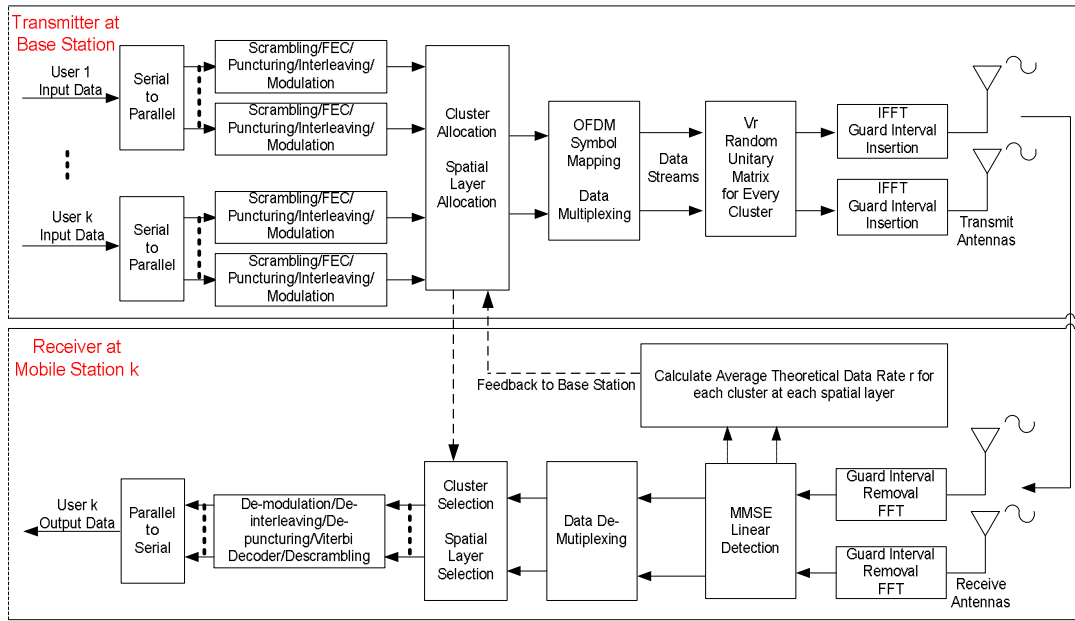

Fig. 1 Block Diagram of RB/LRB-OFDMA PHY Model

II. PHY MODEL

A. OFDMA System

The total bandwidth of an OFDM system is divided into a series of sub-carriers and (provided suitable selection of parameters) each sub-carrier is subject to a flat fading narrowband channel. With proper coding and interleaving across frequencies, OFDM exploits frequency selectivity to its advantage as a source of diversity. For the case of OFDMA, sub-sets of usable sub-carriers can be grouped into multiple sub-channels which are then allocated to different mobile stations for multiple access purposes.

The OFDMA system considered here includes one base station (BS) and multiple mobile stations (MS), which experiences independent fading channels. Transmit data from every MS is processed through the scrambler, channel encoder, puncturer, interleaver and modulator shown in Fig. 1. A cluster allocation mapping process basis (a cluster is considered to consist of an integer number of sub-carriers adjacent in frequency) allocates the data symbols to appropriate subcarriers as indicated by the cluster allocation algorithm (as explained below). OFDM is implemented by means of an inverse FFT and each OFDM symbol consists of 768 data subcarriers. In order to prevent ISI, a guard interval is implemented by means of a cyclic extension. When the guard interval is longer than the excess delay of the channel, ISI is eliminated. A 2x2 MIMO architecture is considered in this paper but the analysis is readily extendible to higher MIMO orders. Perfect channel estimation is assumed.

B. Random Beamforming OFDMA System

Random beamforming was originally proposed for single carrier system in [6] to attain a near optimal channel capacity with reduced feedback. Here this technique will be employed in an OFDM(A) system. A unitary matrix V_r is generated from the random channel matrix H_r and it is applied to the

subcarriers of the OFDMA signal on a cluster basis. Different V_r is generated for different clusters of sub-carriers. The received signal after FFT and guard interval removal becomes:

$$\begin{aligned} Y_k^s &= H_k^s V_r^s X_t^s + N_k^s \\ &= U_k^s D_k^s (V_k^s)^H V_r^s X_t^s + N_k^s \end{aligned} \quad (1)$$

where a subscript k denotes a MS index, s denotes a subcarrier index, H_k^s is a matrix containing MS k 's frequency responses of the channels between N_t transmit and N_r receive antennas at subcarrier s . D_k^s is a diagonal matrix including all the singular values of H_k^s and U_k^s and V_k^s are the unitary matrices obtained by applying SVD to H_k^s . X_t^s denotes an $N_t \times 1$ matrix containing the transmit signals at subcarrier s at the BS and N represents the additive complex Gaussian noise. For a 2x2 MIMO system, the MIMO channels have two subspaces that can be considered as 2 data streams transmitting through 2 parallel sub-channels. For data stream q at every sub-carrier, the MS k computes the ESNR which considers the eigenvalues of the MIMO channels and indicates the channel quality (for simplicity, the subcarrier index is omitted):

$$ESNR_k^q = \frac{|D_k^s|_{qq}^2 |(V_k^H V_r)_{qq}|^2 E_s}{|D_k^s|_{qq}^2 |(V_k^H V_r)_{qj, q \neq j}|^2 E_s + N} \quad (2)$$

where E_s denotes the average symbol energy, and $| \cdot |_{qj}$ indicates the element located in row q and column j . In an OFDMA system, feedback from every sub-carrier in a cluster will be required by the BS. To reduce the feedback for the proposed RB-OFDMA system, every MS calculates the average data rate across all subcarriers in each cluster and sends it to the BS through the feedback channel. For cluster c , if the index of the starting subcarrier is n and finishing subcarrier is m , then the

feedback of cluster c from MS k in frequency domain is:

$$r_{k,c} = \frac{1}{m-n} \sum_{s=n}^m \sum_q \log_2(1 + \text{ESNR}_{k,s}^q) \quad (3)$$

The cluster allocation mapping unit of the BS then uses this feedback information to allocate the common channel of this cluster to the MS with the best $r_{k,c}$. Alternatively, a proportional fair algorithm can be employed where the resources are allocated to the MS when its channel is near its own peak. In this paper, a linear MMSE receiver is adopted for the RB-OFDMA.

C. Layered Random Beamforming OFDMA System

The layered random beamforming technique [7] adopts an MMSE linear receiver to null the self-interference as well as separate the spatial layers of the MIMO structure. As a result, the different spatial layer can be allocated to a different MS based on the ESINR feedback to achieve an additional spatial multi-user diversity gain. On the other hand, it increases the feedback by number of spatial layers (MIMO order – minimum number of transmit and receive antennas) compared to RB scheme. Fig. 1 shows the block diagram of applying LRB to OFDMA system. Similar to the original random beamforming technique, a random precoding matrix V_r is generated and applied to the transmitted signal. Based on $H_k^s V_r^s$, the MS k computes the MMSE filter for subcarrier s , that is:

$$G_k^s = \left((H_k^s V_r^s)^H (H_k^s V_r^s) + \text{SNR}^{-1} I \right)^{-1} (H_k^s V_r^s)^H \quad (4)$$

The received signal is multiplied by G_k^s , and it becomes:

$$G_k^s Y_k^s = G_k^s H_k^s V_r^s X_t^s + G_k^s N \quad (5)$$

MS k then computes the effective ESINR for every data stream for every subcarrier (the subcarrier index is omitted):

$$\text{ESINR}_k^q = \frac{|(A_k)_{qq}|^2 E_s}{|(A_k)_{qj, j \neq q}|^2 E_s + (|G_k|_{qq}^2 + |G_k|_{qj, j \neq q}^2) N} \quad (6)$$

where $A_k = G_k H_k V_r$

The MS k calculates the data rate of each spatial layer on a cluster basis by averaging the data rates of the sub-carriers in the frequency domain, as:

$$r_{k,c}^q = \frac{1}{m-n} \sum_{s=n}^m \log_2(1 + \text{ESINR}_{k,s}^q) \quad (7)$$

For every cluster, the BS allocates each spatial layer of the common channel to the MS whose channel conditions of the corresponding layer are best. The BS informs the corresponding MS about this decision in order to facilitate recovery of appropriate data. Therefore, compared to the RB system, the cluster allocation/selection mapping unit of LRB includes an additional spatial layer allocation/selection mapping process shown in Fig. 1.

The ESINR metric can also be used for RB system with a MMSE liner receiver. In this case, ESINR metric can be used instead of ESINR in equation (3) to calculate the average numerical data rate across all subcarriers in each cluster.

III. PERFORMANCE ANALYSIS OF APPLYING LAYERED RANDOM BEAMFORMING TO OFDMA

In order to evaluate the performance advantage of the LRB-OFDMA system, both numerical and simulated performance are presented and compared with RB-OFDM, LRB-OFDM and RB-OFDMA systems. All OFDMA systems considered at this stage require feedback from every sub-carrier. In order to fully exploit the frequency diversity gain, OFDMA systems adopt 1 sub-carrier for every cluster and allocate every cluster to the best mobile station using a best user selection criterion (greedy algorithm). RB-OFDM and LRB-OFDM are the special cases of RB-OFDMA and LRB-OFDMA respectively, which has all data subcarriers in one cluster.

A. System Setup and Channel Models

The key parameters which are used in the simulation of the system in this paper are the same as those in [8] and are shown in table 1.

Table 1 Parameters for the Proposed OFDMA system

Operating Frequency	5 GHz
Bandwidth	100 MHz
FFT Size	1024
Useful Sub-carriers	768
Guard Interval Length	176
Sub-carrier Spacing	97.656 KHz
Useful Symbol Duration	10.24 μ s
Total Symbol Duration	12.00 μ s
Channel Coding	Punctured 1/2 rate convolutional code, constraint length 7, {133,171} _{octal}

RB-OFDM, RB-OFDMA, LRB-OFDM and LRB-OFDMA are simulated using a MIMO implementation of the channel E of the ESTI BRAN channel models [9]. The ESTI BRAN channel models have a sampling period, $T_s = 10ns$ and the rms delay spread, $\tau_{rms} = 250ns$ for model E.

B. Best User Selection Criterion (Greedy Algorithm)

For the proposed OFDMA system, N_s data subcarriers are grouped into a number of clusters depending on the cluster size. The base station allocates each cluster to one of the mobile stations depending on the feedback. A greedy algorithm is employed to select the best MS in order to maximize the overall system throughput. The greedy algorithm for RB-OFDMA and LRB-OFDMA are described below:

1. RB-OFDMA system

Step 1: The BS collects the numerical average data rate $r_{k,c}$ of all subcarriers in every cluster from every MS.

Step 2: For cluster c , the MS K having the highest $r_{K,c}$ is scheduled for transmission to maximize the overall system throughput.

$$r_{K,c} = \max\{r_{1,c}, r_{2,c}, \dots, r_{k,c}, \dots\} \quad (8)$$

2. LRB-OFDMA system

Step 1: For every spatial layer of the MIMO channel, the BS collects the numerical average data rate $r_{k,c}^q$ of all subcarriers in every cluster from every MS, where q is the spatial layer index.

Step 2: For spatial layer q of cluster c , the MS K with the highest $r_{K,c}^q$ is scheduled for transmission to maximize overall the system throughput.

$$r_{K,c}^q = \max\{r_{1,c}^q, r_{2,c}^q, \dots, r_{k,c}^q, \dots\} \quad (9)$$

C. Numerical Performance of LRB-OFDMA

Fig. 2 to 5 show the numerical average throughput performances of RB-OFDM, LRB-OFDM, RB-OFDMA and LRB-OFDMA employing either ESNR or ESINR metric in channel E. The average throughput of RB system is calculated using equation (3) and the average throughput of the LRB system is the sum of numerical data rates of all spatial layers calculated using equation (7). As a consequence of the use of the greedy algorithm, the average throughput performance of all systems increases with the number of MSs as a result of the increase in spatial multi-user diversity gain. Assuming perfect knowledge of the H channel matrix, the SVD OFDM system capacity bound is also plotted.

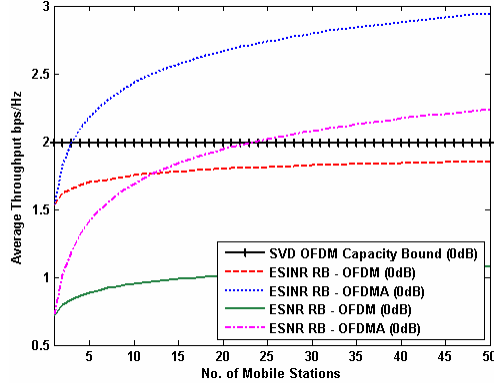

Fig. 2 Average Throughput of ESNR RB-OFDM/OFDMA and ESINR RB-OFDM/OFDMA in channel E as the Number of MSs Changes (SNR=0dB)

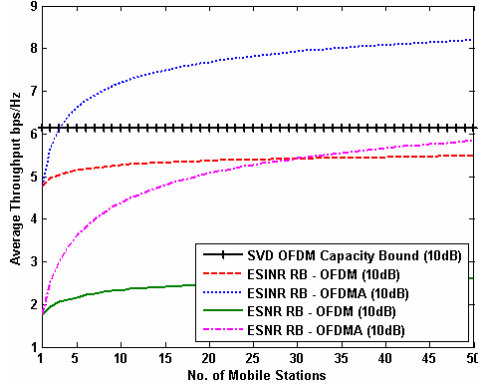

Fig. 3 Average Throughput of ESNR RB-OFDM/OFDMA and ESINR RB-OFDM/OFDMA in channel E as the Number of MSs Changes (SNR=10dB)

Fig. 2 and 3 show the difference in numerical data rate between ESNR and ESINR RB-OFDM/OFDMA systems when the SNR is 0 and 10dB respectively. The ESINR RB system employing a linear MMSE receiver offers much better data rate compared to the ESNR RB system due to its ability to minimize self-interference and noise. For both ESNR and ESINR RB-OFDM systems, because of the high frequency diversity in the channel, some subcarriers may match the randomly generated precoding matrices well while others may have a poor match. Hence, the performance gain obtained by

some subcarriers cancel out the loss experienced by other subcarriers, which results in the worst performance when RB is applied to the OFDM system. For a very frequency selective channel like channel E, frequency diversity gain achieved by OFDMA plays an important role in improving the average data rate as shown in Fig. 2 and 3. As a result, the ESINR RB-OFDMA gives the best performance due to its ability to exploit the spectral and spatial multi-user diversity and minimize self-interference. For low SNR, the ESINR RB-OFDM system performs closer to the SVD capacity bound compared to the same system in high SNR and ESINR RB-OFDMA even outperforms the bound due to spectral multi-user diversity gain in low SNR. This better accuracy of the ESINR RB scheme in low SNR is because the influence of the calculated mismatch (using equation (2)) between V_r and V_k is not significant compared to the effect of noise in low SNR. The accuracy of the estimation of the mismatch in high SNR is improved by adopting the ESINR metric (equation (6)) for the RB scheme, which takes self-interference and noise minimization into consideration.

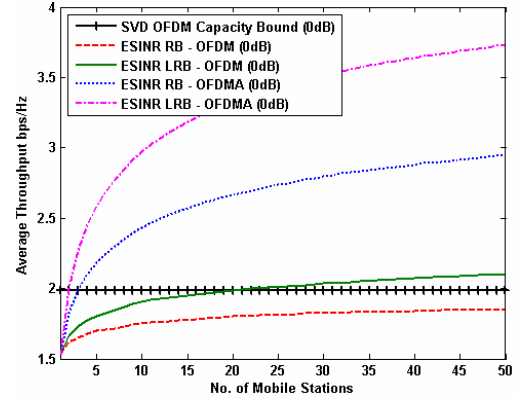

Fig. 4 Average Throughput Performance of RB and LRB OFDM/OFDMA employing ESINR in channel E as the Number of MSs Changes (SNR=0dB)

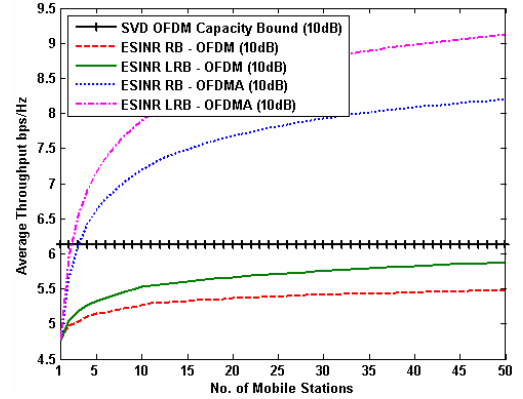

Fig. 5 Average Throughput Performance of RB and LRB OFDM/OFDMA employing ESINR in channel E as the Number of MSs Changes (SNR=10dB)

Adopting an MMSE linear receiver, ESINR RB-OFDM and OFDMA have shown superior numerical data rate performance to ESNR systems in Fig. 2 and 3. The ESINR metric can also be applied to LRB-OFDM and OFDMA system as it is originally proposed for the LRB scheme. Fig. 4 and 5 show the numerical data rates when the ESINR metric is used for both RB and LRB OFDM/OFDMA systems at SNR equal to 0 and 10dB respectively. Compared to ESINR RB-OFDM, ESINR

LRB-OFDM achieves better data rate and even outperforms the SVD OFDM capacity bound for a medium number of MSs as a result of an additional layer multi-user diversity gain. ESINR LRB-OFDMA gives the best performance due to its ability to fully exploit spectral, spatial and layer multi-user diversity gain.

D. Simulation Performance of LRB-OFDMA

To verify the numerical analysis of ESINR RB and LRB systems shown in Fig. 4 and 5, BER performances with 12 MSs in channel E are presented together with single user SM MMSE OFDM in Fig. 6. Based on the assumption of perfect CSI, Single user SVD OFDM is also plotted on the same graph as a reference. In this paper, the transmission mode in [10], which employs 64QAM modulation scheme and $\frac{3}{4}$ coding rate, is considered. Single user SM MMSE system requires no feedback and does not exploit any form of multi-user diversity and therefore has the worst performance. The BER performance of LRB is better than RB due to an additional layer spatial multi-user diversity gain. This result is consistent with the numerical analysis presented in section C which shows LRB schemes outperform RB schemes in terms of data rate. All the OFDMA systems adopting 1 subcarrier per cluster with the greedy algorithm outperform their related OFDM schemes including SVD-OFDM due to significant spectral multi-user diversity gain. Among all the systems, LRB-OFDMA gives the best performance due to its ability to exploit the spatial, spectral and layer multi-user diversity gain.

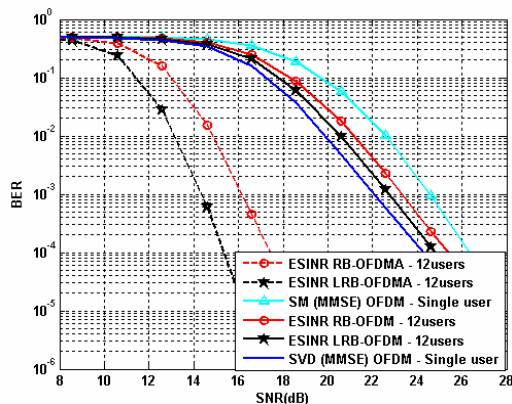

Fig. 6 BER Performance Comparison among RB-OFDM, RB-OFDMA, LRB-OFDM, LRB-OFDMA and SVD OFDM in Channel E (12 MSs in the Environment)

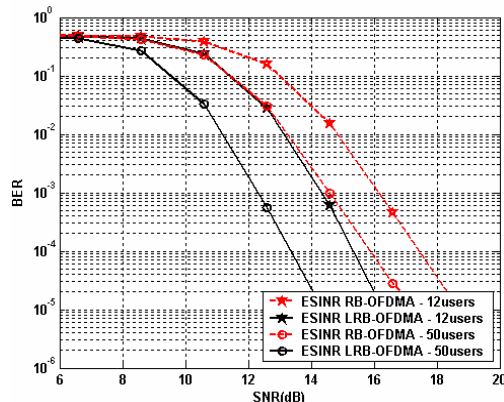

Fig. 7 BER Performance of 12 and 50 MSs RB and LRB-OFDMA (1 Subcarrier per Cluster) in Channel E

Fig. 7 shows the BER performance comparison between a 12- and 50-MS RB/LRB-OFDMA system in Channel E. As the number of MSs increased from 12 to 50, the BER performances of both RB and LRB-OFDMA systems are improved as a result of richer spectral and spatial multi-user diversity gains. This is because it is more likely that the channel of one of the MSs matches well to the randomly generated precoding metric. This simulation result is also consistent with the numerical analysis presented in the previous section.

IV. CONCLUSIONS

By employing the Random Beamforming technique in combination with OFDMA, a next generation system would be capable of effectively exploiting spatial multiplexing capacity gain as well as spatial and spectral multi-user diversity gain. This is achieved at the expense of a requirement, in principle, to have feedback of ESINR information for every sub-carrier. By allocating different spatial layers of MIMO channels to different MSs for transmission, both numerical analysis and simulation result suggests that LRB-OFDMA can further increase the data rate by exploiting an additional layer spatial multi-user diversity gain at the expense of requiring MIMO order times more feedback compared to RB-OFDMA. OFDM sub-carriers can be potentially grouped into clusters and future work will focus on reducing the feedback by generating feedback information on a cluster basis.

ACKNOWLEDGEMENTS

The authors wish to acknowledge the financial support of Dorothy Hodgkin Postgraduate Awards (DHPA) and Toshiba Research Europe Limited (TREL) and to thank Dr. Magnus Sandell of TREL and Dr. Matthew Webb of University of Bristol for their technical input.

REFERENCES

- [1] H. Sampath, S. Talwar, J. Tellado, V. Erceg, A. Paulraj, 'A Fourth-Generation MIMO-OFDM Broadband Wireless System: Design, Performance, and Field Trial Results', IEEE Communications Magazine, September 2002, pp143-149.
- [2] 3GPP; Technical Specification Group Radio Access Network; Requirements for E-UTRA and E-UTRAN (R7)', 3GPP TR 25.913 V7.3.0, March 2006. [Online] Available: <http://3gpp.org/ftp/Specs/html-info/25913.htm>
- [3] I. E. Telatar, 'Capacity of Multi-antenna Gaussian Channels', European Transaction on Telecommunications, vol. 10, pp. 585-595, Nov. 1999
- [4] J. Kim, J. M. Cioffi, 'Spatial Multi-user Access with Antenna Diversity using Singular Value Decomposition', IEEE ICC, June 2000, pp. 1253-1257
- [5] P. Viswanath, D. N. C. Tse, R. Laroia, 'Opportunistic Beamforming Using Dumb Antennas', IEEE Transactions on Information Theory, Vol. 48, No. 6, June 2002
- [6] J. Chung, C. Hwang, K. Kim, Y. Kim, 'A Random Beamforming Technique in MIMO Systems Exploiting Multi-user Diversity', IEEE Journal on Selected Areas in Communications, Vol. 21, No. 5, June 2005
- [7] E. Y. Kim, J. Chun, 'Random Beamforming in MIMO Systems Exploiting Efficient Multi-user Diversity', IEEE VTC Spring, 2005
- [8] A. Doufexi, S. Armour, 'Design Considerations and Physical Layer Performance Results for a 4G OFDMA System Employing Dynamic Subcarrier Allocation', PIMRC, Berlin, 2005.
- [9] J. Medbo, P. Schramm, 'Channel Models for HIPERLAN/2', ETSI/BRAN document no. 3ER1086B
- [10] A. Doufexi, E. Tameh, C. Williams, A. Nix, M. Beach, A. Prado, 'Capacity and Coverage Enhancements of MIMO WLANs in Realistic Environments', ICC, Istanbul, 2006