



Hafezi, P., Wedge, D., Beach, M. A., & Lawton, M. C. (1997). Propagation measurements at 5.2 GHz in commercial and domestic environments. In *International Symposium on Personal, Indoor and Mobile Radio Communications, 1997 (PIMRC '97)*. (Vol. 2, pp. 509 - 513). Institute of Electrical and Electronics Engineers (IEEE). 10.1109/PIMRC.1997.631059

Link to published version (if available):
[10.1109/PIMRC.1997.631059](https://doi.org/10.1109/PIMRC.1997.631059)

[Link to publication record in Explore Bristol Research](#)
PDF-document

University of Bristol - Explore Bristol Research

General rights

This document is made available in accordance with publisher policies. Please cite only the published version using the reference above. Full terms of use are available:
<http://www.bristol.ac.uk/pure/about/ebr-terms.html>

Take down policy

Explore Bristol Research is a digital archive and the intention is that deposited content should not be removed. However, if you believe that this version of the work breaches copyright law please contact open-access@bristol.ac.uk and include the following information in your message:

- Your contact details
- Bibliographic details for the item, including a URL
- An outline of the nature of the complaint

On receipt of your message the Open Access Team will immediately investigate your claim, make an initial judgement of the validity of the claim and, where appropriate, withdraw the item in question from public view.

Propagation Measurements at 5.2 GHz in Commercial and Domestic Environments

P.Hafezi, D.Wedge*, M.A.Beach, M.Lawton*
Centre for Communications Research, University of Bristol
Queen's Building, University Walk
Bristol, BS8 1TR, United Kingdom
Tel: +44 117 928 8618, Fax: +44 117 925 5265
e-mail: P.Hafezi@bristol.ac.uk
* Hewlett Packard Laboratories, Bristol, United Kingdom

ABSTRACT

This paper presents the results of an investigation into the wideband propagation characteristics of four different indoor operational environments within the 5.2 GHz band using a swept time-delay cross-correlator (STDCC) channel sounder. For each environment the cumulative distribution of delay spread for both omni directional and a 20 dB horn antenna are presented. It is shown that a suitably aligned narrowbeam antenna makes possible to achieve delay spread reduction through spatial filtering. The effects of moving people and different room transmission situations are also presented.

1. INTRODUCTION

The emerging advances in digital communications and portable computers have resulted in rapid and widespread expansion of the wireless local area networks. Typical environments that can benefit from such systems are those with a highly mobile workforce often requiring a composite of voice, data and video information. The high data rate requirements together with the need for high capacity and low power necessitates a reasonably large amount of spectrum to be available to such systems. Currently the 5.15-5.35 GHz band has been ratified for HIPERLAN use by the Conference of European Posts and Telecommunications Administration (CEPT).

For all wireless systems a good understanding of the radio propagation channel and the interaction with the environments is necessary if a robust and efficient design is to be proposed. Multipath resulting from reflections, refraction and scattering of radio waves by structures inside a building can cause delays which are of the order of the target operational bit time (10's of ns) and hence may result in intersymbol interference. In order to support high bit rates, systems can employ either equalisation or multicarrier techniques, which are complex and costly, or mitigate these effects of multipath by employing narrowbeam antennas with line of sight (LOS) links. The latter makes possible the use of simple modulation schemes such as FSK or PSK[1].

In order to investigate the impact of narrow beam antenna technology on the measured RMS delay spread here we used an omni directional antenna at the receiver whilst at the transmitter 3 different platforms were considered:

- directional antenna at the transmitter with LOS,
- directional antenna at the transmitter without LOS and,
- omni directional antenna at the transmitter.

The scenarios were repeated for five different indoor environments 3 of which were meeting rooms of various size in different buildings, a residential location and finally an 'office cube' within a large modern open plan office area.

2. Measurement apparatus

A simplified diagram of the swept time delay cross correlator [1] channel sounder is shown in figure 1. The sounder employs a 2047 bit PN sequence to bi-phase modulate a 5.2 GHz carrier wave. The PN generator is clocked at 100 MHz giving the system a minimum time resolution of approximately 10 ns and a repetition period of 20.47 μ s. The resulting 5.2 GHz wideband signal is then amplified and filtered to a 200 MHz band limited signal and transmitted. At the receiver, the received signal is linearly translated back to baseband to derive its inphase and quadrature components. This allows a two channel correlation with a replica PRBS code running 4 kHz slower to be performed. The low pass components of the correlator therefore form the complex impulse response projections of the channel (I and Q). Following the integration the output of the receiver yields:

$$I(t) = \sum \alpha_n RX(t, K - \tau_n) \cos(\phi_n) \quad (1)$$

$$Q(t) = \sum \alpha_n RX(t, K - \tau_n) \sin(\phi_n) \quad (2)$$

where RX is the received signal defined as:

$$RX(t) = \sum \alpha_n s(t - \tau_n) \cos(2\pi f_c t - \phi_n) \quad (3)$$

α_n , τ_n and ϕ_n represent the associated attenuation factor, time delay and phase shift of each received component (n) respectively. $s(t)$ is the PN sequence and f_c is the frequency of the carrier wave. K is defined as:

$$K = f \text{ chip} / \delta f \text{ chip} \quad (4)$$

which represents the time factor arising from the difference in the chipping rates of the two PN sequences. The output components of the receiver were passed on to a computer data acquisition system which performed an 16 bit A/D

conversion of the I and Q signals and then stored for further data processing. Several hundred channel impulse responses were stored for each measurement point. For the measurements where the receiver was moved along a pre-determined path a 3 point averaging was used to calculate the RMS delay spread. Here the receiver was moved a fraction of the wavelength for each averaging point.

3. Measurement environments and procedures

The receiving antenna was a quarter wave dipole with horizontal polarisation whilst at the transmitter a combination of a dipole (similar to that of the receiver) and a 20 dB horn (with 3 dB beamwidth of 15°) antennas were employed. The transmit signal power was set to 100mW and the instantaneous dynamic range of the receiver was 30 dB. When the directional antenna was used, the antenna was adjusted manually to face the transmitter for LOS cases, and for the Non-LOS tests was randomly pointed away from the Transmitter antenna. The height of both transmitting and receiving antennas were set at 1.5m above the ground level. Placing the directional antenna at the transmitter rather than the receiver has the practical advantage that while the receiver may be placed in a cluttered environment with objects nearby, the location of the transmitter can be chosen carefully to avoid reflectors and hence reducing the number of ray paths. The measurements were performed in four different indoor environments:

- An 'office-cube' within a large open plan office area in the Hewlett Packard laboratories, Bristol, UK (location A). The cube was confined to hardboard partitions of 1.6m high and had dimensions of 3mx2m. The office contained no furniture.
- A meeting room (also at HP labs) of 5mx5m with metal walls covered with plastic wall paper (location B). The furniture in this room consisted of a table and few chairs and also video conferencing equipment.
- Two meeting rooms in the ground floor of an 'old' building with stone exterior walls and conventional brick and plaster interior walls. The rooms had dimensions of 10mx7m (location C) and 21mx6m (location D). The smaller room contained a meeting table, few chairs and two white boards while the larger room housed only a few chairs. The windows of both rooms overlooked a large open area. Figure 2 shows a sketch of the room plans. Here the receiver was moved from one end of the room to the other in equal spaced intervals of 1m as shown in figure 2.
- A house in a modern residential area (location E). This was a two story building with brick exterior walls and plasterboard interior walls. Here both transmitter and receiver were placed in the living room. The room had a large bay window overlooking the road outside and was furnished with a large sofa, a television set, a coffee table and a fireplace. Figure 3 depicts the plan of the ground floor of the house.

4. Experimental results

The combined cumulative distribution of RMS delay spread for the three cases described in section 3 are pre-

sented in figures 4 to 8 for the locations A to E respectively.

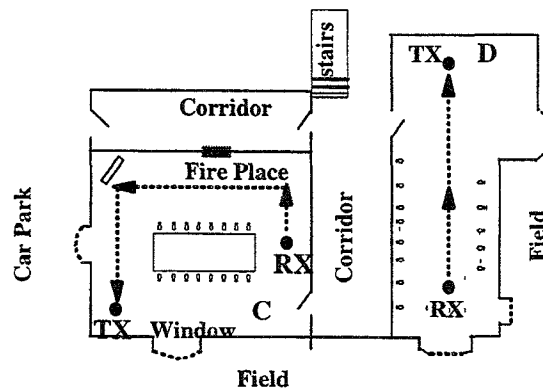

Figure 2 Plan of the measurement locations C and D

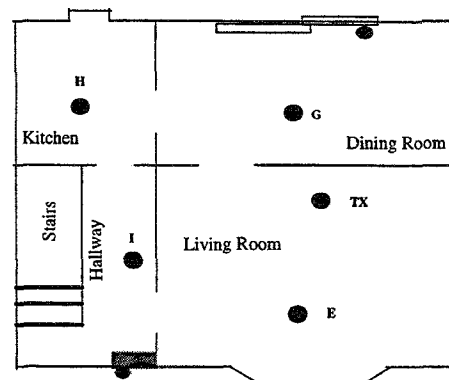

Figure 3 - Plan of the measurement location E

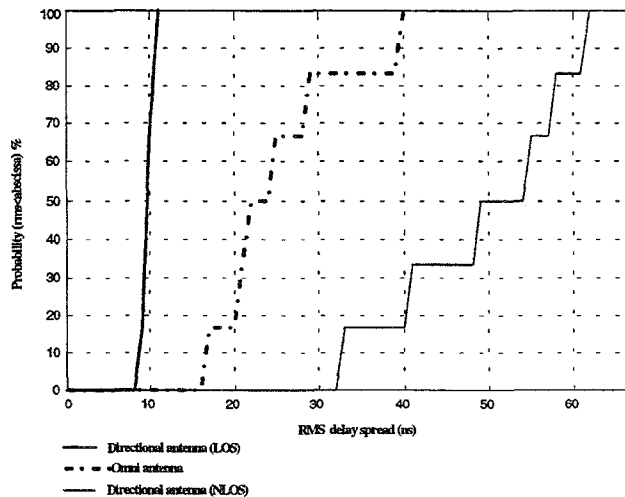

Figure 4 - Cumulative distributions for location A

For the omni-15° measurements with LOS the RMS delay spread values measured did not vary much with the size of the room [3] with typical values being less than 10-12 ns for more than 90% of situations along the route. The exception to this is the location B (the meeting room with metal partition walls) where the values of RMS delay spread were less than 32 ns for more than 90% of the measurements, comparable to the results obtained with the omni-omni antenna configurations. In this environment the multipath can not be avoided by using the directional an-

tenna since they arise from double and higher order reflections from two parallel metal walls, arriving from the same direction as the LOS ray.

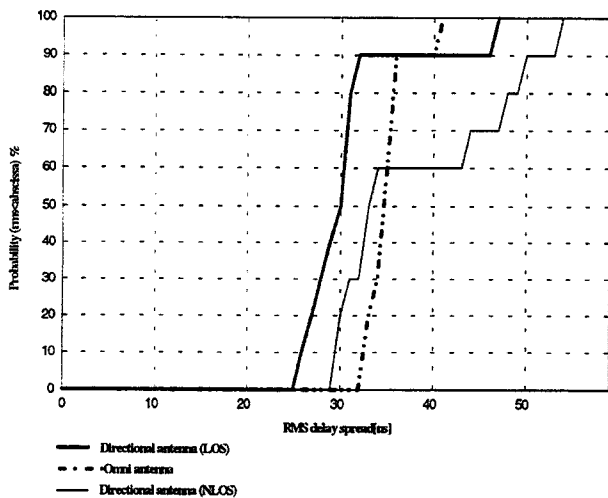

Figure 5 - Cumulative distributions for location B

the result of the moving people. The omni-omni combination appeared to suffer more with increases in the RMS delay of 4-16 ns according to the environment. The exception to this was the results for the 'office-cube'.

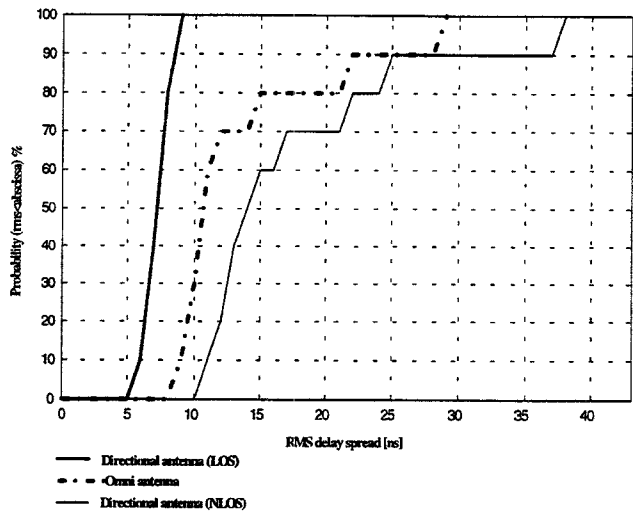

Figure 7 - Cumulative distributions for location D

The values of the RMS delay measured where the omni-15° antenna combination were used with the directional antenna randomly facing away from the Transmitter show a significant increase with respect to those measured by the omni-omni antenna combinations. The delays varied between 25 to 60 ns depending on the environment and the direction which the receiver antenna was facing.

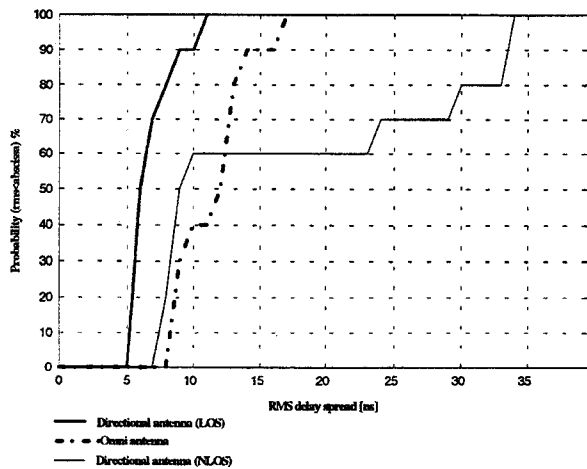

Figure 6 - Cumulative distributions for location C

The omni-omni combination showed a small increase of 2 ns as the result of moving people. Generally for the omni-omni antenna combination it can be said that the effect of human body shadowing on the average RMS delay spread measured varied according to the objects within the environment and the type of the walls. This can be seen from the figures given for the two meeting rooms in the 'old' building (locations C and D). As the smaller meeting room was more densely furnished than the larger room, the shadowing due to human body had less impact on the values of the RMS delay.

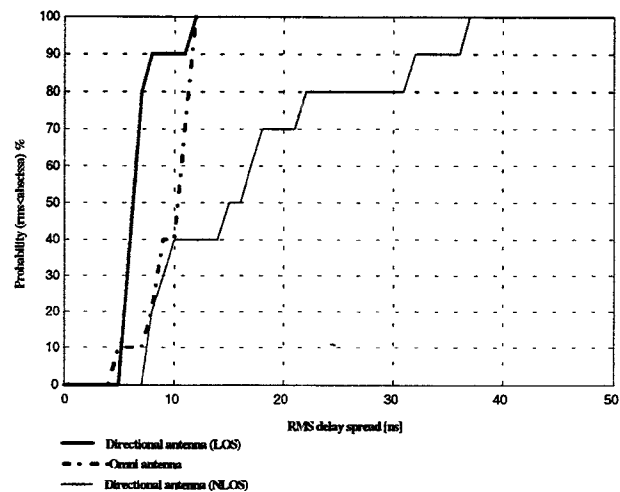

Figure 8 - Cumulative distributions for location E

The effect of moving people on the measured RMS delay was investigated by keeping both the transmitter and the receiver fixed in each of the environments under the test. People then randomly moved between the transmitter and receiver. Figures 9 and 10 show the probability distribution of the RMS delay spread for both omni-15° and omni-omni configurations for the location A and compare the results of human shadowing to when the room was empty. Table 1 lists the results for the cases where transmitter and receiver were kept fixed in the empty locations to those where people were moving. Generally the average values measured increased slightly (typically 1-4 ns) with the omni-15° as

Finally, Table 2 lists the results for the different room transmission scenarios using omni-omni antenna configurations. Location F refers to the measurements taken in the 'old' building. Here the transmitter was placed in the corridor while the receiver was in the small meeting room. Locations G, H and I refer to cases where the transmitter was placed in the living room while the receiver was placed in

the lounge, kitchen and hallway of the house (as shown in figure 3) respectively. The probability distribution of the RMS delay measured where the transmitter was in the small meeting room of the 'old' building and the receiver was placed in the corridor is shown in figure 11. The values of the RMS delay spread for omni-omni Obstructed LOS situations were generally higher in the 'old' building than those measured in the house mainly due to the difference in the type of the interior walls in the two locations (brick walls in the 'old' building and plasterboard walls in the house).

5. Conclusion

Wideband multipath measurements at 5.2 GHz from 5 different indoor environments have been presented. It has been shown that with the exception of the room with the metal partitioning walls, the RMS delay spread measured with the omni-15° antenna combination were less than 11 ns for more than 90% of the situations. This showed a considerable improvement over the cases where omni directional antennas were used at both ends (40 ns for the worst case). It has been shown that the non-optimal alignment of the directional antenna can cause a significant increase in the values of the RMS delay spread. Measurements of human body shadowing in different environments suggest that the furniture and surrounding objects within the rooms under the test played an important role on the variations of the RMS delay values. Low delay spread values measured in the domestic environments suggest that simple multipath mitigation techniques (such as simple diversity schemes) may be sufficient in order for high speed wireless LANs to be supported. The commercial environments considered in this study however were much more severe (high delay spread values in the meeting rooms and the office cube) and therefore there will be a need for more sophisticated anti-multipath techniques (equalisation or multitone) for the above systems to operate.

Acknowledgements

The authors would like to thank Hewlett Packard laboratories, Bristol, for the funding and support of this project, and Professor J.P.McGeehan for the provision of facilities. P.Hafezi would also wish to thank Y.Sun for his helpful guidance during the course of this work.

References

- [1] P.F. Driessen, 'Gigabits/s indoor wireless systems with directional antennas', IEEE Trans. On Communications, VOL.44, No.8, August 1996, pp1034-1043.
- [2] D.C. Cox, 'Delay Doppler characteristics of multipath propagation at 910 MHz in suburban mobile radio environment', IEEE Trans., 1972, AP-20,(5),pp.625-635.
- [3] P.F.M. Smulders and A.G. Wagemans, 'Wide-band measurements of mm-wave indoor radio channels', PIMRC'92, Boston, MA, October 1992, pp. 329-333.

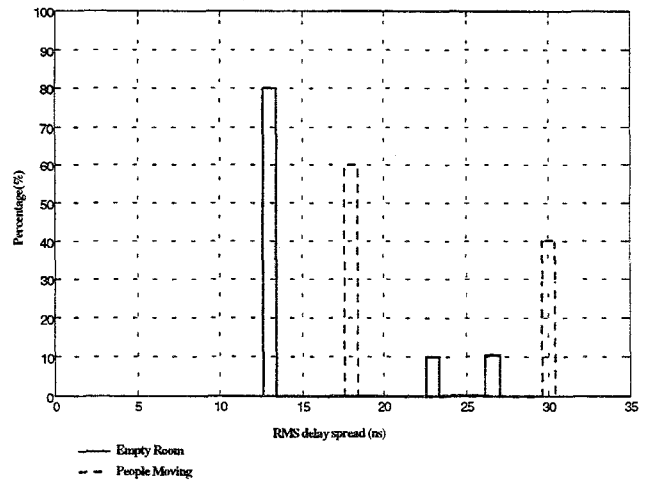

Figure 9 - Probability Distribution of RMS delay for location A with people moving (omni:15° configuration).

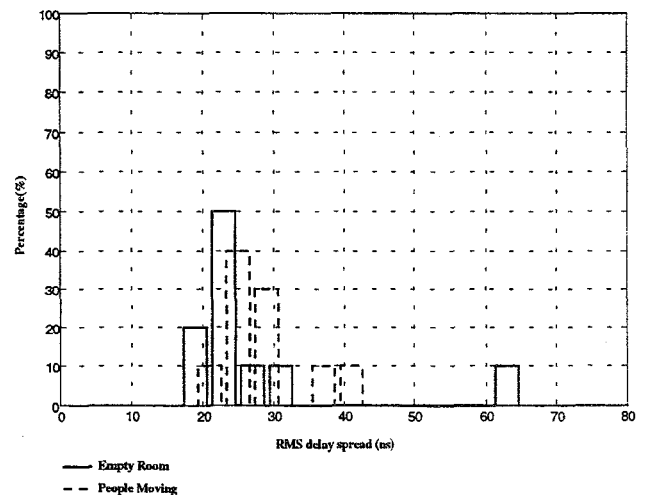

Figure 10 -Probability Distribution of RMS delay for location A with people moving (omni:omni configuration).

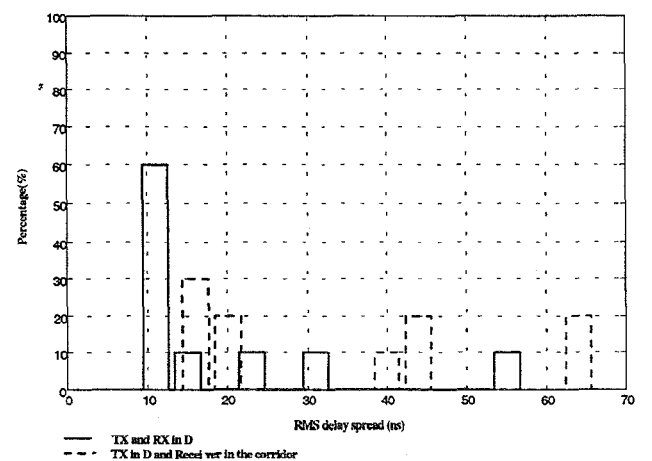

Figure 11 - Probability Distribution of RMS delay for different room transmission situation (Location G - omni:omni configuration).

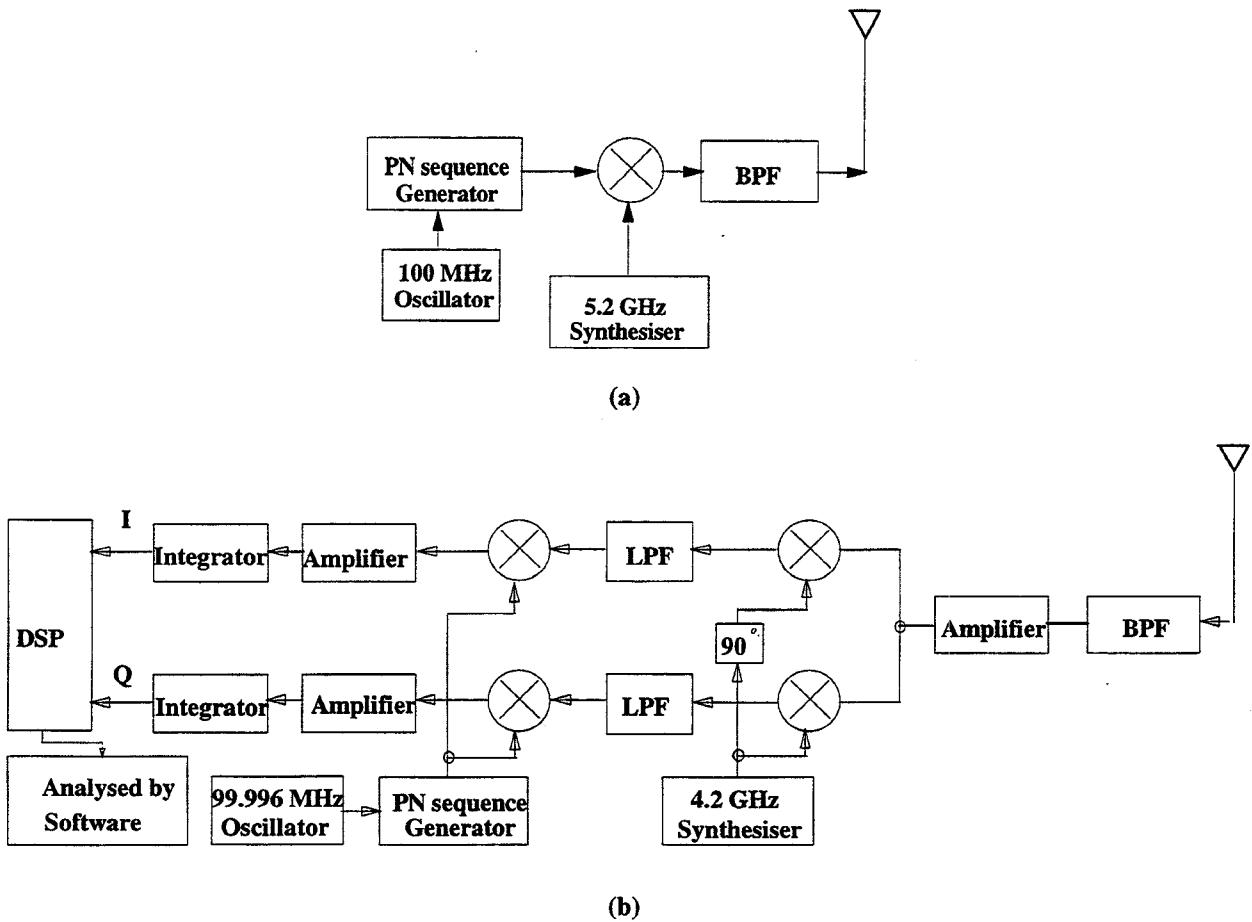

Figure 1 - Block diagram of the channel sounder (a) Transmitter (b) Receiver

LOCATION	Average RMS Delay measured (ns)				HORN (NLOS)
	OMNI		HORN (LOS)		
	Empty room	People moving	Empty room	People moving	
A	28	29	17	21	56
C	14	18	8	10	18
D	20	36	8	9	19
E	12	23	8	9	18

Table 1 - Average value of RMS Delay Spread measured for each location

Location	F	G	H	I
Average RMS Delay (ns)	40	12	13	15

Table 2 - Average value of RMS Delay spread measured for different room transmission using an omni antenna at the receiver