



Kaleshi, D., & Barton, M. H. (1999). Ensuring interoperability in a home networking system: a case study. *IEEE Transactions on Consumer Electronics*, 45(4), 1134 - 1143. 10.1109/30.809193

Link to published version (if available):
[10.1109/30.809193](https://doi.org/10.1109/30.809193)

[Link to publication record in Explore Bristol Research](#)
PDF-document

University of Bristol - Explore Bristol Research

General rights

This document is made available in accordance with publisher policies. Please cite only the published version using the reference above. Full terms of use are available:
<http://www.bristol.ac.uk/pure/about/ebr-terms.html>

Take down policy

Explore Bristol Research is a digital archive and the intention is that deposited content should not be removed. However, if you believe that this version of the work breaches copyright law please contact open-access@bristol.ac.uk and include the following information in your message:

- Your contact details
- Bibliographic details for the item, including a URL
- An outline of the nature of the complaint

On receipt of your message the Open Access Team will immediately investigate your claim, make an initial judgement of the validity of the claim and, where appropriate, withdraw the item in question from public view.

ENSURING INTEROPERABILITY IN A HOME NETWORKING SYSTEM: A CASE STUDY

Dritan Kaleshi, Michael H. Barton
 Centre for Communications Research, University of Bristol
 Merchant Venturers Building, Woodland Road
 Bristol BS8 1UB, UK
 {Dritan.Kaleshi, M. H. Barton}@bristol.ac.uk

Abstract

One of the main problems in Home Networked Systems is the wide diversity of technologies, application requirements and cost allowance for devices and systems in general. This is translated to a division into different islands of technology that goes down to single manufacturer systems, thus blocking the way to the system integration as the main reason for the existence of the network. It is widely accepted that achieving the interworking is the most important aspect of a system specification.

Object-oriented modelling associated with proper application management mechanisms for trading and binding provides the best approach to standardisation work on home systems interworking. We take here as an example the work toward an interoperability specification for an energy management system. The system described spans several communication media and brings together several consumer and producer entities. The system aims to provide increased comfort while either minimising the usage of resources or their cost for the same level of usage. Results from installed and running systems show the success of the approach.

1. Introduction

Home networked systems (HNSs) is a concept that applies to the networking and application technologies that allow the connection of computers, audio and video equipment and home automation subsystems (energy management, security, safety, heating and ventilation, etc.) in an integrated co-operating environment to increase the comfort and ensure sharing and management of home resources as well as the provision of new, enhanced services.

Interest in home networking has increased significantly in the last two years. This can be attributed to many technological factors and market forces. The continuous increase in the computational power of microprocessor-based systems, associated with the continuous decrease in their cost, has ensured their widespread use. The staggering development of the Internet, and the new concepts and possibilities that its development has opened and is bringing into every facet of technology, offer realistic ways for the integration of the information, processing and control for every individual user and device. Nevertheless this is still rather far from being the reality in the user community.

The home is under attack from different industries: telecommunications, broadcast, information technology and consumer electronics. We are witnessing increasingly that the industries are overlapping and competing with each other in the approaches that they follow to solve the problem of accessing residential users and providing services to them. These services are spanning several application and information domains, and are becoming more and more packaged and integrated. One of the features necessary for the success of these approaches is the existence at the service level of a networked system capable to support the delivery and usage of these services – a Home Network System. A successful HNS needs:

1. to develop, assess and adapt to network transport technologies for both the in-home and residential access networks, with a clear view to their integration.
2. to identify, define and harmonise the services to be provided, and find the right driving forces behind

them. Here the work varies between the different areas, with the entertainment industry most likely to take the lead with new applications and services already proven to appeal to the residential user.

3. to build a system and application architecture with proper management facilities capable of blending a multitude of products of widely varied capabilities. Ensuring a transparent and seamless integration of the different technologies and concepts required at this level is one of the main obstacles to the successful uptake of such systems.

On the home side several specifications exist already, mainly for home automation (CEBus[1][2], HHS[3], HIB[4], BatiBUS[5], LonWorks[6], HBS, X10, etc.), all of different technology characteristics and of different market penetration, while new initiatives are producing alternative approaches, such as the VESA Home Networking Group for a home network proposal based on the IEEE P1394 (High Speed Serial Bus) standard and IP[7]. On the other hand the network technologies for the "last mile access" with CATV, ISDN, xDSL, and Digital Power Line are in different stages of standardisation and implementation. Some authors [8][9] report on research on ATM-based home networks, looking at ways to facilitate the integration with the access networks. Also the Internet community is considering extensions of the IP protocol to cater for IP-based home networks[10].

It has been shown in the literature that major problems exist in points 1, 2, and 3, and a successful integrated HNS solution seems still elusive. Two problems are generally underlined, namely the cost of the devices and technology aimed at a consumer market; and the requirement for the system to provide reliable self-configurable application integration through interworking/interoperability standardisation work. While the first is a genuine concern, nonetheless we believe that it is sometimes overstated; the second issue is the one that requires the main attention.

It is obvious that a diverse range of solutions will exist for some time to come. Efforts will be made to put the different islands of technology existing in an HNS together through dedicated pieces of hardware and software. So, while competition will continue in the foreseeable future on the networking technologies to be used, the issues there should be addressed in parallel with the issue of ensuring interworking between the applications in and around the home. This follows the idea that the ultimate target in the home will be the seamless integration of services and applications spanning the whole technological world that surrounds the residential users. Several solutions exist in the IT world, but the acceptance of these solutions by the home networking com-

munity until recently has been quite conservative, mainly owing to their perceived expense and complexity.

2. The interworking problem in the home

The division above between the network and the application interworking worlds could be seen as natural, although the choices made in either of the areas are by no means completely free; they are mutually dependent. Nevertheless, no matter what road the networking technology takes and what prevails in the end, the need for concerted and standardised work toward the integration of HNS applications is obvious. The more open this process is, the greater will be the benefits to system and service providers, manufacturers and users.

It is our belief that this work will initially follow the current experience: specific areas are covered separately, as they exist today. But with the ultimate aim being to integrate all these subsystems together this process could be facilitated and made future-proof if a common model were adopted in the work. Extensive research has been done in the computing world to solve similar problems; in [11], [12] the relevance of one of them, the Open Distributed Processing model (ODP), has been investigated and proposed as a solution applicable to the home automation (sub-)systems to achieve the above integration.

The HNSs, covering mainly home automation, were concerned initially with the specification of the communication system for control; generally little consideration was given to provide the necessary support for the distributed nature of the applications. There is a noticeable shift now, understanding that while specifying the communication system ensures that every device can "hear" what the other devices are "saying", this is by no means enough - it is as important to ensure the "understanding" of what the other devices are saying. Furthermore, mechanisms should be provided to establish this "understanding" while systems evolve in time. The interoperability work must address these in a future-proof way.

As most of the HNS devices will differ generally in minute details which, nonetheless, are considered by the manufacturer and the user the distinguishing feature for the product, the object-oriented approach to the definition of the interworking standards is accepted as the only feasible way to model the HNS applications. This approach is followed widely in different documents such as [13] and [14].

The problem facing these Home Automation System (HAS) interoperability working groups is the same as that of every object management community: how to provide for soundest interworking in the face of both the evolution of devices in time and the existence of numer-

ous devices with very often minute functional differences.

Two approaches may be identified in the existing definitions of an object model in the HNS domain:

1. one that follows a relatively rigid abstract structure, based on multicast communication and with explicit non-evolving definition of data types, very often at the last stage of system installation. As a rule the corresponding systems require specialist installation and configuration (application binding); and
2. one that follows a (primitive) hierarchical model with automatic discovery and trading mechanisms leading to component binding (*ad hoc* discovery at run-time), which allows automatic application configuration.

Both of the above object-oriented models reflect to a great extent the communication model of the adopted systems. This is usually justified if one takes into consideration size and cost issues for the majority of the devices in the HNS. The issue becomes more influential if the choice of the communication model was made to support an object-oriented language at the application or user level in the first place. Several of the existing specifications for home automation have embedded object support for the approach at user or application level (like EHS and CEBus); others have recognised the need and have started to support this approach in upper layers (structured EIB Application Objects).

In this paper we try to present how the second approach above can be followed to realise an interoperability specification of an energy management system using object-oriented modelling associated with system management mechanisms to support object/device discovery and binding existing in the European Home Systems (EHS) specification [3].

The interoperability standardisation work was based on the EHS specification, and so a very brief introduction to EHS may be necessary.

3. European Home Systems

EHS is a European specification for home networking systems. The scope of the EHS specification is the domestic environment, extending to multiple-apartment systems for energy management, safety and security. The specification is maintained by the European Home Systems Association in an open way, in the sense that all members have free access to the specification and related technologies.

The basic feature that makes it very appealing for consumer home automation electronics products is that the EHS exhibits full plug and play characteristic by allowing the installation/connection of the devices into

the system and the discovery of the services/devices in the network without any (or with very minimal) user intervention.

3.1 Application Architecture

EHS uses a client/server architecture. Any process in any device may take the role of a server and advertise services to the networked installation where it is connected. Any process in any device may take the role of a client, finding and using services of the servers around the system. The servers in EHS are comparatively simple, less powerful devices, while the intelligence of the system is localised in the clients.

The discovery of the services, or *trading*, is completely distributed within a single system. This relies on the multicast communication service of the protocol, through which either :

- each server offers its services to the system; interested parties (clients) establish the application links; or
- each client broadcasts (multicasts) requests for particular services; eligible servers respond by identifying themselves to the requesting party, thus allowing the establishment of the application links.

The specification distinguishes between logical processes and physical units. Each process is called a *device*; a server device is called a Complex Device, while a client is called a Feature Controller. More than one process can reside in the same physical unit, run concurrently and either provide or use services locally or over the whole system to other processes.

4. Communication

EHS claims adherence to the OSI 7-layer Reference Model, although only four of the layers are actually specified, namely the Physical Layer, the Data Link Layer, the Network Layer, and the Application Layer.

EHS devices can use power line, twisted pair, coaxial cable, or wireless (RF and IR) – although only power line and twisted pair media are used in practice.

The Network Layer is relatively simple, and provides for packet routing in the network. EHS devices use source routing, making the address of a device dependent on its position in the network.

The Transport, Session and Presentation layers of the OSI model are empty – some functionality normally modelled to reside in these layers has been moved to the application layer, which is divided into two service modules: the Message Transfer Service Element and the Command Language Service Element (CLSE). CLSE is the interface between the underlying commu-

nication system and the user application, which is specified using the EHS Command Language (CL).

4.1 Command Language

EHS CL is an object-oriented common application language which is used to model and build distributed applications using EHS. It is provided to hide the intricacies of the communication system from the application developers.

EHS is a message-driven system. The application in a client activates via a message some service(s) in an object residing in the servers, requiring the execution of a routine or the value of some data. The format of a CL message is:

Object	Service	[Data]
--------	---------	----------

Objects are atomic entities, with one or more services (methods) applicable to them. Objects are uniquely identified in a system by an object identifier. The objects are classified into *groups* corresponding to major household activities or applications, such as heating, energy management, security etc. Within the group the hierarchy is flat, with no guidelines to further refine existing objects in a structured way.

Services are basically remote operation procedures like *read* (RD), *write* (WRT) etc. They return *data* from the atomic object using the syntax defined in the interoperability documents.

A comprehensive list of objects for EHS home automation applications is built through co-operation of industry partners in EISA Interoperability Working Groups (IWGs) and it is maintained and checked to ensure consistency by EISA.

4.2 System and Application Management

The EHS defines mechanisms for automatic network installation of devices as well as for the discovery of the services/applications. They give to the specification its strong plug and play characteristic. These mechanisms are tied closely with the naming and object hierarchy, and this is where the experience described here is considered relevant.

The process of discovering and establishing application links between devices is called *enrolment*. The main object used in the discovery process is the "name" of a device, which is called *device descriptor*. The device descriptor represents an identifier of a collection of objects from the EHS Object Tables residing in a device (process) and being accessed through standard predefined services (methods), or offering services like event notification.

The device discovery process is enriched further by providing extended trading mechanisms that allow detailed queries to be built during the enrolment process. A particular device (process) may enquire in the system for devices supporting particular objects, or even particular methods on these objects, and choose from the possible response(s).

This in turn requires detailed definition of the groups of objects corresponding to device descriptors: as always in this case the design choice is between defining a detailed and large class hierarchy allowing for very fine details to be present and to direct the trading mechanism in a system, or a flat class hierarchy with refinements provided by manufacturer and possibly not of complete interest or usage by everybody else beyond an agreed minimum set of services.

4.3 EHS devices : two viewpoints

As mentioned above, an EHS device is defined as an addressable logical process composed of atomic objects. From this definition a device could be seen as a class, which implies specifying the attributes, the methods applicable to these attributes, and implementation considerations.

On the other hand, the formal definition of a device as a composition of objects also serves as the basis from which different *contracts* could be built and used by other devices through the trading mechanism to realise the application binding. At this level one is not interested any more with the implementation issues, but simply with (some) specific criteria modelling the external behaviour of the device, expressed in the form of the composing objects. From this viewpoint a device could be viewed as *an interface*.

There are several reasons for considering these viewpoints. The first is that the devices are, by definition, collections of objects (atomic objects in the case of EHS). As such the first attempt of an application specification group would be the identification of all the objects participating in different (ideally all of the) scenarios of the application under consideration. This is the approach followed in existing home automation interoperability specifications. But the more encompassing the interests of the Interoperability Group (IOG), and the more scenarios it considers, the larger will be the number of objects identified as participants in the application. It is accepted that not all of the identified and standardised objects will be implemented in a particular device/system – especially when the work is done at a generic level. Thus, from the pool of objects a subset of objects is identified and used to compose a device. The question arises: how will other devices in the HNS get knowledge of the capabilities of a device? How will the contention be-

tween two apparently similar devices be solved? The answer lies in the interface viewpoint of the devices. It is to be noted that this requires not only the object-oriented modelling atomic entities participating in HNS application to achieve interoperability, but the envisioning of trading mechanisms based on an identifiable interface hierarchy. Although this division may seem quite abstract, especially considering the fact that an interface concept is a special derivative of the class concept, it is our experience that it is easier to model and work toward the consensus required for an interoperability specification following this division. In practice this addresses the accepted orthogonality of the issues of the semantics and syntax one faces in the specification of a distributed processing application; trying to specify the system in these steps overcomes the unnecessary blurring of the two. In the end, the work based on the combination of the class and interface viewpoints should produce a type hierarchy for the devices.

Hence we can consider a device *as a collection of at least one interface*; this naturally leads to the concept of *one device exposing several interfaces*, each identified by a separate identifier. This context has not been investigated in full in home automation systems, and from similar work in the IT world maintaining and updating such a hierarchy of interfaces is as difficult work as it is necessary.

5. Energy Management System

5.1 Interest in Energy Management

The electricity industry is identified as one of the parties most interested in home networking systems, until now mostly in home automation applications, although the case is certainly expressed for other narrowband or broadband applications. This industry is becoming more sensitive to home networking in deregulated markets. For example, currently the residential users in the UK have the possibility of buying electricity from any supplier from the UK or abroad on half-hourly contracts, although this is not yet deployed for residential customers as the necessary set-up greatly outweighs the benefits to such users. Nevertheless the industry is faced with increased competition, making the value-added services a distinguishing and desired characteristic. The possibility of value-added services becomes more viable if one considers that the electricity utilities have almost global access to every home (apart from some very remote independently supplied locations), and an extensive parallel information and control network down to the secondary substations. As such it is possible to gain easy access to homes to provide a wide range of services, among which energy management is the most appealing and natural to the

industry itself. Nevertheless we must note that the uptake of this opportunity from the industry has been rather slow because of the immature and largely non-standardised home automation market as well as the somewhat conservative mentality of the industry in regard to taking the leading role in these new untried areas.

5.2 The application

Two strategies are followed by the electricity utilities to realise energy management:

- Direct Load Control (DLC), where the utility controls directly, according to its own policy, the use of the resources by the major household consumer appliances/systems on behalf of the residential user.
- Demand Side Management (DSM), mainly through real-time pricing. The utility exercises its policy by providing different pricing for the supply at different times, and making this information available to residential users; the ultimate control of the household energy consumption resides with the users themselves.

In Europe it is mainly the second method and its variations that are used. Typical examples are systems in (partial) use in:

1. Denmark – *Real-Time Price*. In this case the utilities distribute the actual price of electricity, in local currency, and the time of applicability to the end system (meter / utility gateway).
2. France and UK - *Real-Time Price indication*. In these systems the utility distributes information *indicative* of the price of the electricity; the time of applicability is fixed.
3. UK - *Real-Time Cost indication* (UK). In this case the utility distributes the electricity cost-to-the-utility to the system to be used for the energy management. No direct relationship to the actual price to the end user exists; the driving force behind this is the utility pledge that the reduced cost achieved as result of the use of this management strategy will be passed on eventually to the users through lower prices.

In all the three systems the characteristic common component is the resource management information provided by the utility to the home system. This information is usually in the form of arrays of tuples $\{price, time\}$, indicating the actual price or indicative price or indicative cost per unit of the resource (electricity) and the applicable time for this price. This information is distributed to the customer premises by

radio broadcast (UK), ripple control (France), public paging system (Denmark), or PSTN (UK, Denmark).

This information is to be used by the home system in any of the following ways:

1. Centrally controlled operation. In this scenario an energy manager entity is part of the system. This is an *intelligent* controller process capable of building and exercising a complex management strategy of all the manageable home system components based on the user requirements, utility management information as well as other information, like weather forecasts, usage patterns, etc. (Fig.1a.)

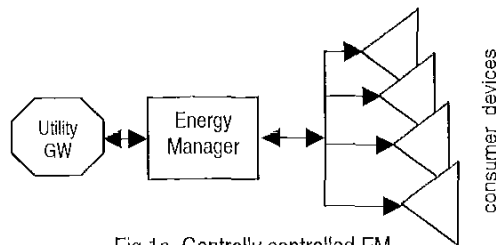

Fig.1a. Centrally controlled EM

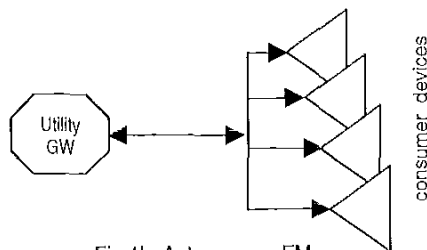

Fig.1b. Autonomous EM

2. Autonomous active operation. In this case home automation devices will perform *individual* energy management functionality based on the user requirements and utility management information; there is no concerted effort system-wide. (Fig.1b)

It is obvious that the mode depicted in Fig.1b can be used only in cases when there is no limit to the resource supply to the home automation system as a whole, otherwise the only choice is a system like Fig.1a. Also it is to be noted that cluster-based energy management will actually fall under Fig.1b above in regard to the overall energy management application in a home system.

5.3 Interoperability

The aim of this work is to define a type hierarchy for devices participating in a *generic* energy management application. We start by describing the application environment, the system configuration, and the detailed definition of the devices. The type hierarchy could then be used as a template to be applied in the

respective country contexts and still ensure the interworking of the devices.

The objective of the interoperability specification work in ETHOS was to specify the system so that the manufacturers of the components of the home system interested in including energy management functionality could be shielded from the differences in the communication method used to convey the management information to the residential users, or the format used for it in Fig.1a or Fig.1b. Beyond this the specification aims to ensure that:

- products from different manufacturers should work together in the same application;
- the products should not interfere with products for a different application;
- the manufacturers should be free to compete at the level of functionality or features provided in their devices.

5.3.1 Application Environment

The energy management is based on tariff- / cost-related information sent from the utilities to the customer's premises using different media and methods of transmission. The information sent from the suppliers to the home system is represented in different ways. Thus the main function of the specification is the provision of a common "resource advice" to the home system (heating system and domestic appliances) to use the given resources. The "common" refers to its being the same device, with the same interface, independent of the country of deployment, utility policy, utility information, or utility communication methods. This reference acts as a common interface between the home system and the (possibly several) supplier(s) the home system may connect to.

The generic application is based on the assumption that the utility/supplier transmits at regular intervals a tariff profile to the customer's premises. The tariff profile is composed of applicable tariff rates and their respective times of applicability. The utility / supplier may as well provide resource management advice, again in a form of advice profile.

No further assumptions are made about this information or the way it is transmitted. For this reason the interpretation of this information onto a common understandable form will be utility dependent.

5.3.2 Configuration

The architecture of a system developed in the ETHOS project is given in Fig.2. The entities participating in this application are:

Supplier(s): They provide the resources to be used, as well as furnishing information on how to manage the resource usage. In this case their role is passive, as it does not *directly* control any aspect of the application.

User(s): They use the system to achieve their aims such as to increase comfort or to economise the usage of the resources; they should have absolute priority on the usage of resources within the boundaries of the contract they have agreed on with their supplier(s).

Home System Component(s): They could be individual devices or clusters of devices. They employ user preferences and the information provided by the *supplier(s)* to perform their functionality. Examples are a heater controller(s), a washing machine / dryer, an energy management / load management controller.

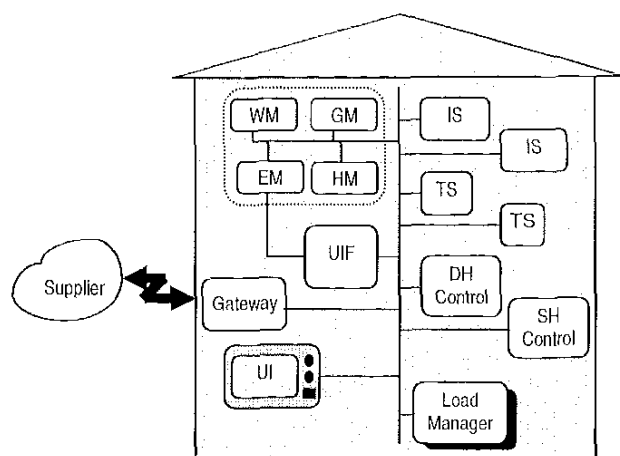

Fig.2. ETHOS System Architecture

xM	meter module (Water, Electricity, Gas, Heat)
UIF	Utility Interface
UI	User Interface (generic module)
DH/SH	Direct / Storage Heating controller
IS	Intelligent Socket (networked intelligent power relay)

The information exchanged between these entities is:

- *consumption* in the meter;
- *time-related tariff / cost* from the supplier;
- *user preferences*.

The energy management application covers the management of energy resources used by the heating system, hot water system, and main electrical domestic appliances (washer, tumble dryer, dishwasher etc.), which represent the largest consumers of energy resources in a home.

The specification is inherently location-transparent; there is no assumption as to the physical location of the different components of the system. They could be located inside the customer premises or not, depending on other factors, namely the utility policy on types of contracts, their approach to equipment ownership, installation and maintenance, etc., or from the fact that these services could be offered by a third party, a service provider that may stand between the house system and the utilities, here known as "supplier".

The principle behind the management scheme is the transmission from the utilities (or suppliers) of tariff- and, possibly, cost-related profiles. These consist of a list of tariff rates and their respective time of applicability. There are no constraints as to what period of time is covered by the given tariff profile, which could be downloaded on daily, weekly, monthly, or seasonal bases. The same is valid for cost-related profiles.

In the context of this application, the main aim of the interoperability specification is to provide a common representation of utility DSM-like information into the home system, providing in this way the basis for the installed home system to offer the same level of service independently of which supplier is providing its information.

Based on this and also on the fact that end-applications will be designed under country-specific requirements, the configuration here should provide a framework for a generic approach to such a system. Parts of the system may not exist in applications, but the framework defined in the interoperability specification should accommodate for their feature interworking where and when they are implemented.

The configuration consists of:

1. **Meter(s)**
Meters provide the system with information about consumption, its rate, and possible warnings to the system that it is overusing the resources. The devices may provide their services to both the in-house system and the supplier side, when appropriate functionality from the supplier side is specified and implemented. Meters for different utilities (electricity, gas, water, heat) are considered under the same generic hierarchy, allowing for the same approach to meter device definitions for different utilities.
2. **Utility Interface**
This provides the interpretation of the tariff and cost-related information sent by the utility / supplier to commonly understood values for the in-house system. These values may be further processed by a load manager unit. The device could

operate under two scenarios. The Utility Interface (UIF) could be simply a gateway between the supplier(s) and the HAS, or it could provide the HAS with processed management advice information built using the utility price-related information and the utility / manufacturer policy. This dual functionality of the UIF provides for coexistence of both user and supplier defined policy to the usage of resources, allowing the migration, if necessary, or the overlapping, if desired, of the two policies in a user-transparent way.

3. Other Components

These include a heating system, load actuators (connected to non-intelligent electrical loads), intelligent domestic appliances, etc. They could operate either cluster-based or autonomously, using the information provided by the meter and the UIF devices.

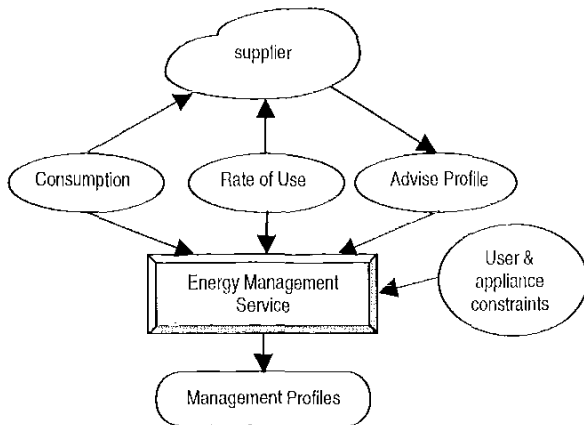

Fig.3. Information Model

The application information model is given in Fig.3. The entities represented here are logical; no assumption is made on their location or the syntax associated with the information.

In particular, the energy management service could be distributed or central, or any combination of both (see Fig.1a, 1b).

The main information is the Advise Profile build by the utility interface based on the price/indicative cost/indicative price information provided by the supplier(s). The Advise Profile presents the utility policy to the home automation system in a transparent way. It has the form of an array of tuples {float: *value*, time: *time*}, denoting respectively a threshold “economy” value and the time of its applicability. If the current price/indicative cost reference read from the utility meter is above this threshold value, it is not economical to use the resources. For a 4-tier contract, where

price1 < ... < price4, the mapping table would be of the form:

Price	Price1	Price2	Price3	Price4
Advise Level	64	127	192	254

and a daily profile might be:

price	P3	P1	P2	P1	P4	P2	P1
time	06:30	08:30	12:30	14:30	18:00	22:00	24:00
advise	192	64	127	64	254	127	64

The energy management service needs only to optimise the {advise;time} sequence according to the user and appliance / system constraints in order to realise the required functionality.

If the user changes the contract and / or the supplier, the relative nature of the advise profile ensures that the energy management application does not need to change; it will simply operate based on a different set of relative values.

As the mapping function is controlled by the utility, more complex mapping can obviously be used to exert the utility DSM policy.

5.3.3 Device Type Hierarchy

The requirement is to allow home appliances from different manufacturers that implement energy management services to be able to operate across different countries, and to be transparent to the possible change of the electricity supplier or the contract. The first step is the adoption of the Advise Profile. But still the differences between the countries and / or suppliers operating in these countries are such that the utility gateway interface will be different. The solution adopted in this case is the definition of a type hierarchy of devices that implement the defined functionality. The type hierarchy adopted in the ETHIOS project for the meter devices and their objects are given in Fig.4 and Fig.5 respectively.

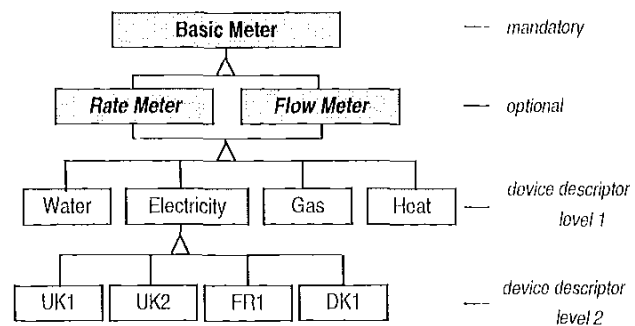

Fig.4. Meter type hierarchy

These abstract types provide the pool for the different types of meters. To actually define the different utility meters the objects are *syntactically instantiated*, i.e. a definite data structure is associated with each of the services supported. This definition gives the actual *Electricity Meter*, *Water Meter*, etc. A separate device descriptor identifies each one. At this level it is ensured that a device advertising the respective device descriptor will support the above objects and their defined services.

The problem of having several objects identified as optional could be solved in two ways:

- An application management mechanism is defined that allows for testing the presence or not of a particular object from the general pool of objects identified in the *Basic*, *Rate* and *Flow Meter* types.
- A different device descriptor is assigned to different device subtypes. For example, the device *UK1*, which is an *Electricity Meter* type, supports additional objects, and is identified by a level 2 device descriptor.

Basic Meter
Serial Number
Installation Number
Manufacturer Code
User Name
Cumulative Units Consumed
Tariff Rate

Rate Meter
Maximum Allowed Rate
Overrate Warning
Max Measured Rate
Time of Max Measured Rate
Interval for Rate Meas.

Flow Meter
Measured Flow
Maximum Allowed Flow
Overflow Warning
Maximum Measured Flow
Time of Max Measured Flow

The first approach is not very economical in terms of traffic, especially if the subtype differs from the parent type by a significant number of objects. Also the degree of freedom that this approach allows to the implementers makes it even more difficult to manage, counteracting the reason for having the interoperability specification.

The trading process is very rapid using the second approach. Also, because the management of the device descriptors is generally centrally regulated by an association (in this case by the EHSA), it removes the element of uncertainty introduced by the first approach. In addition, this allows the graceful upgrade or exten-

sion of the HNS, as a newer unit could project two device descriptors (interfaces), allowing coexistence with older parts of the system. This is particularly important for retrofitting residential systems.

Of course, as with any object model, the depth of the typing should be kept small to simplify the management of the hierarchy, as well as to offer the required flexibility at a low implementation price.

6. Installed systems

A generic interoperability specification for energy management application extended with the subsystems (like heating) or individual intelligent actuators (load controllers, heater devices) was produced in the EU-funded ETHOS project (ESPRIT 20304). The specification was used as the basis to produce system specification in France, Italy, Denmark, and the UK. The systems have been installed in 700 residential homes and flats.

Domestic appliances implementing energy management services, either individually or in clusters, were manufactured based on the generic interoperability specification, using the interface as defined by level 1 device descriptor for electricity meter and utility interface. The appliances did not require adaptation while being deployed in all the four countries, independently of the different utility DSM policies, providing the first instance when a cross-country multi-utility field trial of this scale has been successful.

7. Conclusions

While the number of electronic communication-capable devices is increasing every day, connecting them together to provide extended functionality requires more than the design and specification of a network technology; it requires interworking devices able to create and destroy application relationships (ideally) without, or with very minimal, user interference. This is realised through interoperability specifications. Experience both in the computing world and home systems has shown that this task involves substantial difficulties; in the HNS it is made more difficult owing to the existence in and around the home of a large number of entities with very different capabilities as well as with the same functionality but differing in minute features. One approach to solve this problem and somehow help to focus the interoperability group's work to more important issues (like the application functionality definition) instead of communication intricacies is the use of object-oriented modelling to build a device type hierarchy. We have tried to show here that for the interoperability to be ensured a type hierarchy of devices must be defined, and the underlying distributed system must provide proper trading

and binding mechanisms to allow the specification of future-proof interoperable systems. The case of the interoperability specification for a pan-European energy management system based on the EHS specification was presented in brief. The results of the field trials with systems using the EHS specification, allowing for the same domestic appliances to be installed and operate unmodified in four different countries in systems connected to seven different electric utilities, prove the necessity and feasibility of the approach described here.

Acknowledgements

This work has been supported by the Commission of the European Union (CEU) under the ESPRIT project 20304 "ETHOS – Energy and Communication User Services (Multimedia) Field Trials of Developed Home Systems to European HS (EHS) Protocols and Specifications" and by the Department of Electrical and Electronic Engineering, University of Bristol, UK. The set of ETHOS interoperability specifications were developed in close co-operation with the project's industrial partners: EA Technology Ltd (UK), Eastern Electricity (UK), Electricité de France (France), ENEL (Italy), DEFU (Denmark), Midland Electricity (UK), Schneider Electric SA (France), ST Microelectronics (France), and SWALEC (UK).

References

- [1] Evans, G. The CEBus Standard: User's Guide, May 1996.
- [2] <http://www.cebus.org/tech.htm>
- [3] European Home Systems Specification, Release 1.3, EISA Zaventem, Belgium, March 1997.
- [4] EIBA Handbook Series, Release 3.0, EIBA, Brussels, Belgium, February 1998.
- [5] <http://www.batibus.com>
- [6] <http://www.echelon.com/Core/abf/onWorks.htm>
- [7] DiGirolamo, J, Humpleman, R., The VESA Home Network Initiative (white paper), VESA Home Network Committee, ver2, 1999.
- [8] Greaves, D.J., Bradbury, R.J. Warren: A Low-Cost ATM Home Area Network, *IEEE Network*, January 1998, pp.44-56.
- [9] Cucos, A., Corcoran, P.M. Real-time ATM for Remote Access to Home Automation and Digital home A/V Networks, *IEEE Transactions on Consumer Electronics*, vol.44 n.3, August 1998, pp.482-488.

- [10] Miller, B. *et al*: Home Networking Device and Service Discovery Requirements, *Internet Draft*, February 1999.
- [11] Munro, A. Home Automation Systems: ODP in the Kitchen?, *Proceedings of IFIP TC6/WG6.1 International Conference on Open distributed Processing, II*, Berlin, 13-16 Sept 1993, pp.277-288.
- [12] Munro, A., Kaleshi, D., Barton, M.H. Demand Side Management: ODP in your Electricity Meter? *International Conference on Open Distributed Processing*, Toronto, May 1997.
- [13] HomePnP Specification, *CEBus*, 1997.
- [14] EISA, Guidelines for a Home Systems Interoperability Specification, *EISA Zaventem, Belgium*, August 1994.
- [15] Rumbaugh, J et.al., Object-oriented Modeling and Design, *Prentice Hall*, 1991.

Biographies



Dritan Kaleshi graduated with an Excellent Diploma in Electronic Engineering from the Polytechnic University of Albania in 1991. Until 1996 he was a lecturer with the Department of Electronic Engineering at the Polytechnic University of Tirana. At present he works as a Research Assistant with the Networks and Protocols Group at the Centre for Communications Research, University of Bristol, UK. His main interests include access network and home area network technologies, object-oriented programming and distributed computing.



Michael H. Barton gained his BSc in 1972, before working as a design engineer for ICL in the UK. He subsequently undertook doctoral studies, gaining a PhD in 1981. Since 1982 he has been a Lecturer, and then Senior Lecturer, in the Department of Electrical and Electronic Engineering at the University of Bristol. His research is in the field of Networks and Protocols, with interests in distributed and re-configurable systems.