



Hetzel, S. A., Bateman, A., & McGeehan, J. P. (1991). A LINC transmitter. *Electronics Letters*, 27/10, 133 - 137. 10.1109/VETEC.1991.140461

Link to published version (if available):  
[10.1109/VETEC.1991.140461](https://doi.org/10.1109/VETEC.1991.140461)

[Link to publication record in Explore Bristol Research](#)  
PDF-document

## University of Bristol - Explore Bristol Research

### General rights

This document is made available in accordance with publisher policies. Please cite only the published version using the reference above. Full terms of use are available:  
<http://www.bristol.ac.uk/pure/about/ebr-terms.html>

### Take down policy

Explore Bristol Research is a digital archive and the intention is that deposited content should not be removed. However, if you believe that this version of the work breaches copyright law please contact [open-access@bristol.ac.uk](mailto:open-access@bristol.ac.uk) and include the following information in your message:

- Your contact details
- Bibliographic details for the item, including a URL
- An outline of the nature of the complaint

On receipt of your message the Open Access Team will immediately investigate your claim, make an initial judgement of the validity of the claim and, where appropriate, withdraw the item in question from public view.

# A LINC Transmitter

S.A. Hetzel, A. Bateman and J.P. McGeehan

University of Bristol  
Centre for Communications Research  
Queens Building, University Walk  
Bristol BS8 1TR, United Kingdom  
Tel: +44 272 303259, Fax: +44 272 255265

## Abstract

The LINC (*L*inear amplification using *N*on-linear *C*omponents) transmitter shows considerable potential for use in future mobile radio systems employing spectrally efficient linear modulation formats. Its theoretical 100% average power efficiency and linearity making it extremely attractive for use in handportables where battery size and life are at a premium.

An experimental LINC transmitter is described that utilises modern digital signal processing (DSP) techniques to perform accurately the necessary signal component separation within the transmitter. A technique for significantly reducing the bandwidth required for this digital signal processing is outlined, and practical results are presented which demonstrate that the linearity of the transmitter compares favourably with established linearising techniques such as cartesian feedback.

## 1 Introduction

The recent massive growth in the number and density of mobile radio users has put increasing strain on scarce spectral resources, often resulting in overcrowded radio channels. This situation has precipitated the effort to develop systems which are more spectrally efficient than the traditional FM based schemes currently in use. Both analogue (e.g. AC-SSB) and digital (QPSK, M-QAM etc.) formats are being considered but in each case the message information is conveyed in both the amplitude and phase of the transmitted signal. The result is an RF channel bandwidth that is considerably less than that required using any of the FM type systems and hence increased spectral utilisation. These "spectrally-green" linear modulation schemes must use a more sophisticated transmitter however as their non-

constant envelope signals require linear amplification. This means that the relatively power efficient but non-linear Class C based transmitters of present systems cannot easily be utilised. Unfortunately, conventional linear amplifier classes are inefficient making them unsuitable for most handportable systems.

Many linearising and/or efficiency boosting techniques utilising conventional amplifier classes have been proposed as a solution [1, 2], but all suffer a fundamental limit to theoretical efficiency performance. Generally speaking this limit is set by the theoretical efficiency characteristic of the particular amplifier class utilised. This could typically be 75–100% at PEP but usually falls to far less at lower envelope levels, tending to 0% efficiency at zero output level. LINC (*L*inear amplification using *N*on-linear *C*omponents) is one of the most promising of a group of more radical "alternative techniques" that achieve linearity without any such limit (*i.e.* 100% theoretical efficiency at all envelope levels).

The LINC transmitter relies upon the fact that a general bandpass signal,  $S(t)$ :

$$S(t) = E(t) \cos[\omega_c t + \phi(t)] \quad (1)$$

can be split into two constant envelope phase modulated components,  $S_1(t)$  &  $S_2(t)$ , as follows:

$$\begin{aligned} S_1(t) &= E_{max} \cos[\omega_c t + \phi(t) + \alpha(t)] \\ \text{and } S_2(t) &= E_{max} \cos[\omega_c t + \phi(t) - \alpha(t)] \end{aligned} \quad (2)$$

where  $2S(t) = S_1(t) + S_2(t)$   
and  $\alpha(t) = \cos^{-1}[E(t)/E_{max}]$

These components are separately amplified, and then summed together at a high level to produce an amplified version of the original bandpass signal. The constant envelope nature of the phase modulated signals means that highly non-linear but very efficient amplifiers can be used.

Whilst the LINC concept (sometimes called out-phasing or dephasing) has been in existence since the 1930's, the generation of the two component signals  $S_1(t)$  and  $S_2(t)$  has always been inaccurate as the  $\cos^{-1}$  phase term is difficult to implement using analogue techniques [3]. Modern Digital Signal Processing (DSP) technology has made a significantly more accurate component separator possible [4], and the linearity performance of the transmitter is now dominated by the RF gain and phase match between the two amplified components. Recent literature has addressed the theoretical degradation in performance for a given mismatch [5, 6], and this paper complements this work by providing practical results for a LINC transmitter utilising these techniques together with a method for significantly reducing the bandwidth of the digital signal processing required.

## 2 An Experimental LINC Transmitter

The phase modulated components are generated using quadrature DSP techniques performed at baseband. Rather than operating on the RF signals  $S(t)$ ,  $S_1(t)$  &  $S_2(t)$  their baseband equivalents,  $s(t)$ ,  $s_1(t)$  &  $s_2(t)$  are used. The baseband input signal,  $s(t)$ , (in complex polar form) is:

$$s(t) = r(t)e^{j\phi(t)} \quad \text{where } r(t) = E(t)/E_{max} \quad (3)$$

and  $0 < r(t) \leq 1$

The two phase modulated components,  $s_1(t)$  &  $s_2(t)$ , are:

$$s_1(t) = e^{j[\phi(t)+\alpha(t)]} \quad (4)$$

and  $s_2(t) = e^{j[\phi(t)-\alpha(t)]}$

where  $2s(t) = s_1(t) + s_2(t)$  and  $\alpha(t) = \cos^{-1} r(t)$

In the experimental digital signal processing these are generated by adding and subtracting the perpendicular projection,  $e(t)$ , of the input phasor  $s(t)$  onto the unit circle (Figure 1). Hence

$$s_1(t) = s(t) + e(t) \quad (5)$$

and  $s_2(t) = s(t) - e(t)$

Now

$$e(t) = \sqrt{1-r^2(t)} e^{j[\phi(t)+\frac{\pi}{2}]} \quad (6)$$

$$= j\sqrt{\frac{1}{r^2(t)}-1} r(t)e^{j\phi(t)}$$

$$= j\sqrt{\frac{1}{r^2(t)}-1} s(t) \quad \text{where } (0 < r(t) \leq 1)$$

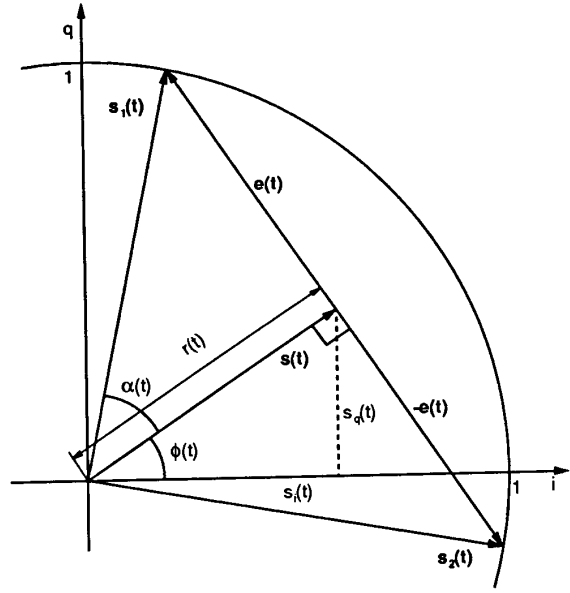

Figure 1: Baseband Component Separation Phasors

Rewriting in cartesian complex form,

$$s(t) = s_i(t) + js_q(t) \quad (7)$$

And thus

$$e(t) = -s_q(t)\sqrt{\frac{1}{s_i^2(t)+s_q^2(t)}-1} \quad (8)$$

$$+js_i(t)\sqrt{\frac{1}{s_i^2(t)+s_q^2(t)}-1}$$

A Motorola 56000 based DSP system is used to realise these functions (Figure 2). The baseband message is input in cartesian form as IQ input channels  $s_i(t)$  and  $s_q(t)$ . In order to achieve maximum throughput, the function to generate  $e(t)$  is implemented as a two dimensional lookup table. The phase modulated components are produced by simply adding and subtracting  $e(t)$  to/from the input signal  $s(t)$ , to form the two sets of IQ output channels  $s_{1i}(t)$ ,  $s_{1q}(t)$  and  $s_{2i}(t)$ ,  $s_{2q}(t)$ . The RF phase modulated signals  $S_1(t)$  &  $S_2(t)$  are generated from these signals using conventional IQ upconversion mixing techniques.

The RF component signals  $S_1(t)$  and  $S_2(t)$  drive two identical amplifier chains (Figure 3). Initially 7 Watt Class C modules have been utilised and a combination of high power attenuators and a low power hybrid used for summation. This test configuration,

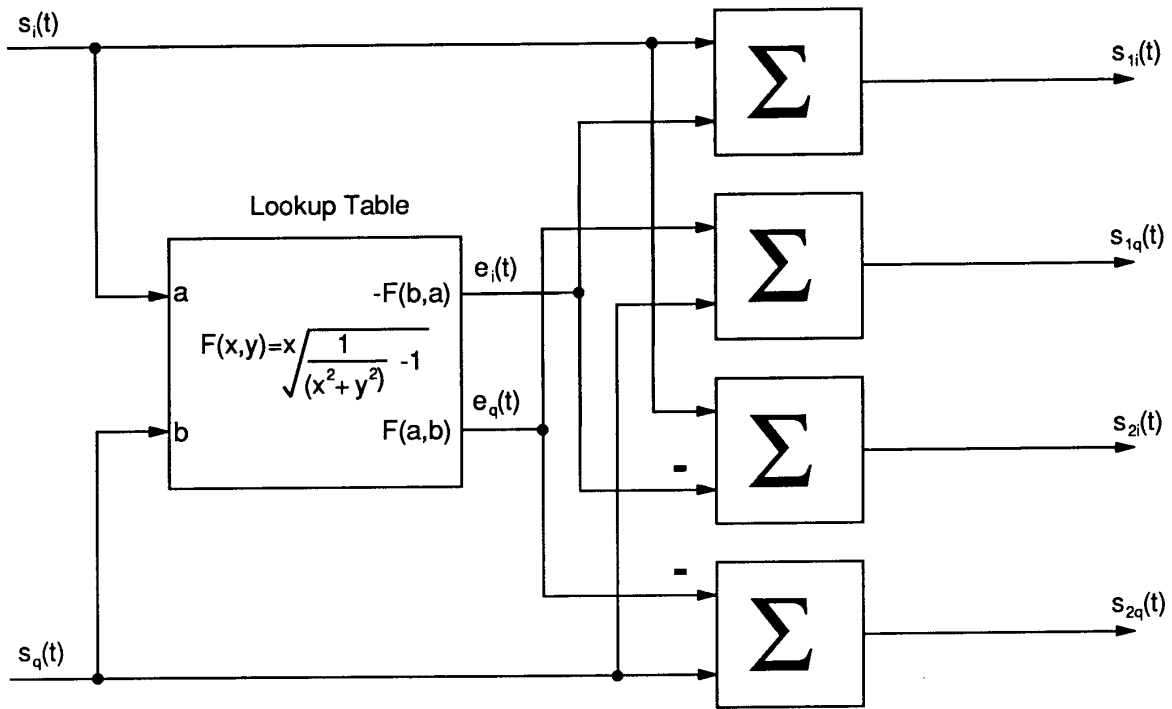

Figure 2: Baseband Signal Processing

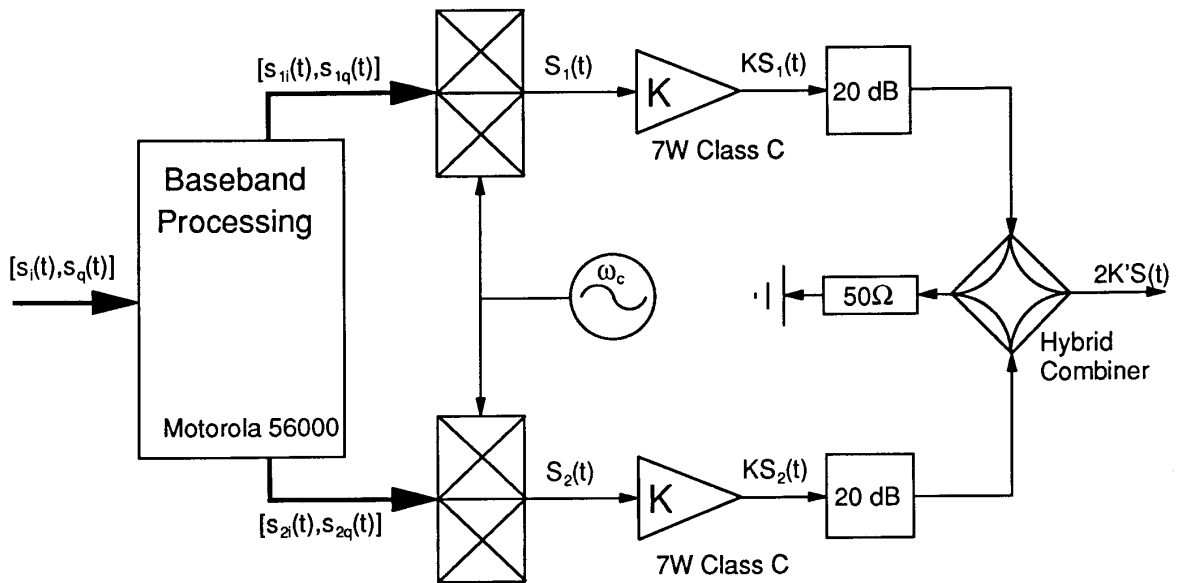

Figure 3: Experimental LINC Transmitter

although far from efficient, accurately enables the linearity of the system to be evaluated, and the realisation of acceptable RF gain/phase match tested. The present configuration operates in the VHF band at a centre frequency of 170 MHz.

### 3 Component Signal Bandwidths

Figure 4 shows the spectrum of one of the constant envelope component signals  $S_1(t)$  for a two tone input signal. The signal is extremely wideband and in fact alias components are present within the reconstruction filter bandwidth because of limited DSP sampling rate. The wideband nature of the signal components are due to instantaneous phase discontinuities that occur when the envelope of a two tone signal passes through zero. This is a direct consequence of the fact that the baseband processing described so far assumes the domains of the variables  $r(t)$  and  $\phi(t)$  to be:

$$0 < r(t) \leq 1 \quad \text{and} \quad -\pi < \phi(t) \leq \pi \quad (9)$$

Alternative domain definitions can be used with equal validity and result in much narrower band signal components for the specific case of a two tone input signal. Unfortunately wideband signals are produced for other simple inputs such as a single tone.

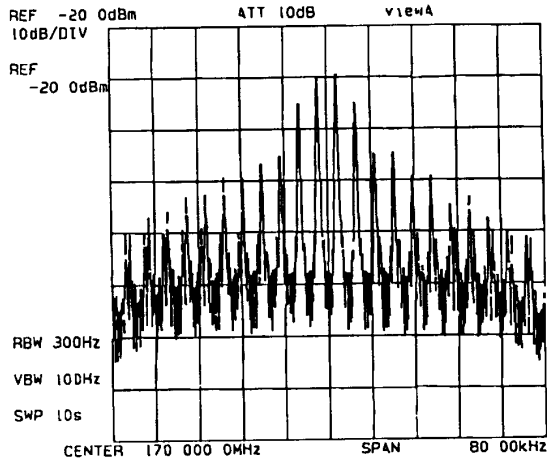

Figure 4: Broadband RF LINC Signal Component,  $S_1(t)$

By realising that the two signal component phasors effectively swap over (i.e.  $s_1(t)$  becomes  $s_2(t)$  and vice

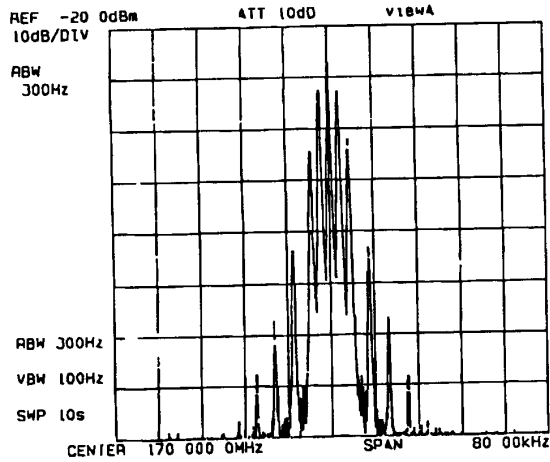

Figure 5: Narrowband RF LINC Signal Component,  $S_1(t)$

versa) when the envelope of the two tone input signal crosses through zero it is possible to take account of these changes and swap the phasors back again. The current system exploits this technique resulting in the much narrower band component signal of Figure 5, and significantly reduces the DSP sampling rate required for the baseband processing.

### 4 Results

Figure 6 shows the output spectrum of the LINC transmitter for a classical two tone test. The tones are at 2.2 kHz above and 1.4 kHz below the carrier and at a level sufficient to just reach PEP. Sufficiently accurate component separation and RF gain/phase matching has been realised for residual frequency component levels to exceed 60 dB below the wanted tones. The asymmetry of the distribution of these components about the two tones suggests that they are caused by more complex second order effects rather than a simple RF gain/phase mismatch. Possibilities include slight deficiencies in the baseband processing and intermodulation between second and third order harmonics of the fundamental components occurring in the various amplifier stages. These effects are currently being investigated at Bristol.

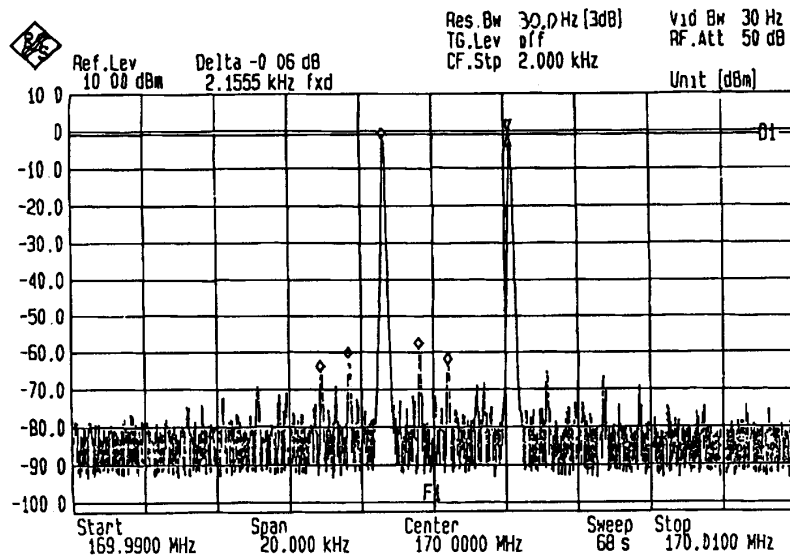

Figure 6: LINC Transmitter RF Output,  $K'S(t)$

## 5 Conclusions

A practical prototype LINC transmitter has been constructed exploiting modern DSP techniques to generate the necessary baseband phase modulated signal components. A method to reduce the DSP sampling rate required for this processing by decreasing the bandwidth of these phase modulated signals has been outlined. Sufficiently accurate signal separation and recombination has been realised in the prototype system and excellent cancellation of unwanted components achieved.

The linearity of the transmitter has been shown to be comparable with that of linearising techniques such as cartesian feedback which have already been investigated for use in future systems. More accurate DSP based signal component separation and automatic RF gain/phase matching techniques under development at Bristol should improve the linearity still further. At the same time more efficient amplifier and signal combining techniques are being explored to exploit more fully the inherent power efficiency of the LINC system.

## 6 Acknowledgements

The authors would like to thank SERC and Motorola Ltd for their joint support of the CASE award in connection with this work.

## References

- [1] WILKINSON R.J., MACLEOD J., BEACH M.A., BATEMAN A.: "Linear Transmitter Design for MSAT Terminals", Second International Mobile Satellite Conference, June 17-20 1990, Ottawa, Ontario, Canada, pp. 297-301.
- [2] KOCH M.J. and FISHER R.E.: "A High Efficiency Linear Power Amplifier for Digital Cellular Telephony", 39th IEEE Vehicular Technology Conference, May 1-3 1989, San Francisco, CA, USA, pp. 17-18.
- [3] COX D.C.: "Linear Amplification Using Non-linear Components", IEEE COM-22, December 1974, pp. 1942-1945.
- [4] BATEMAN A., WILKINSON R.J., and MARVILL J.D.: "The Application of Signal Processing to Transmitter Linearisation", IEEE 8th European Conference on Electrotechnics, 1988, pp. 64-67.
- [5] CASADEVALL F.J., and OLMOS J.J.: "On the Behaviour of the LINC Transmitter", 40th IEEE Vehicular Technology Conference, May 6-9 1990, Orlando, Florida, pp. 29-34.
- [6] CASADEVALL F.J.: "The LINC Transmitter". RF Design, Feb 1990, pp. 41-48.