

AN EVALUATION OF THE HYGROTHERMAL PERFORMANCE OF 'STANDARD' AND 'AS BUILT' CONSTRUCTION DETAILS USING STEADY- STATE AND TRANSIENT MODELLING

D. Mumovic¹, M. Davies¹, I. Ridley¹,
T. Oreszczyn¹, M. Bell², M. Smith² and D. Miles-Shenton²

¹The Bartlett School of Graduate Studies, University College London, WC1E 6BT, UK

²School of the Built Environment, Leeds Metropolitan University, LS2 8BU, UK

ABSTRACT

Accurate assessment of both surface and interstitial condensation risk at the design stage of buildings is of great importance - not just to minimise the damaging effects moisture can cause to building envelopes, but also to contribute to the provision of adequate indoor air quality. Guidance certainly does exist with regards to limiting thermal bridging in order to prevent condensation occurring on new constructions. However, a recent study has provided clear evidence that the reality, both in translating the available guidance into a specific design and in construction on site is often rather different from the 'ideal'. This paper reports on that study and compares and evaluates the hygrothermal performance of construction details for different phases during the building life cycle. The results of both the surface and interstitial condensation risk simulations under both steady-state and transient conditions are presented and discussed. Significant differences in the hygrothermal performance of 'standard' and 'as built' construction details are observed.

INTRODUCTION

Accurate assessment of both surface and interstitial condensation risk at the design stage of buildings is of great importance - not just to minimise the damaging effects moisture can cause to building envelopes, but also to contribute to the provision of adequate indoor air quality. Relevant Guidance has been published in the UK (DTLR, 2001) in the form of a set of 'Robust Construction Details' (RCD), published in support of the 2002 revision to Part L¹ of the Building Regulations for England and Wales. This document aims to help the construction industry to deliver the relevant performance standards and provides a formal route to regulatory compliance.

However, the reality, both in translating the available guidance into a specific design and in construction on site are often rather different from the 'ideal' as set out in the RCD document. In a survey, conducted as

¹ Part L sets out energy performance standards for buildings.

a part of this study, fifteen different construction sites were identified (Bell et al., 2004). As a result of the survey, a set of nineteen different RCD cases were selected for both surface and interstitial condensation risk assessment. The modelling phase of the project, the methodology of which is presented in this paper, sought to identify the extent to which the 'as built' details give rise to a significantly increased condensation risk as compared to the relevant 'standard' robust construction details, as defined in the guidance.

In addition to assessing 'as built' performance, the study sought to investigate the suitability of the relevant calculation methods used to assess the risk of surface and interstitial condensation and mould growth. The calculation methods currently used in the UK are specified in the following standard – BS EN ISO 13788: 2002: "Hygrothermal performance of building components and building elements – Internal surface temperature to avoid critical surface humidity and interstitial condensation methods" (BSI, 2002a). Although recently revised, it is recognised that the new Standard contains limitations (Sanders, 2003). These limitations have arisen from the assumption of non-transient heat and moisture transport. In order to address this issue, a comparison was made between the results obtained for surface and interstitial relative humidity using both 'simple' steady state and 'complex' transient models. The results of this comparison provide a quantitative indication of the types of 'errors' which simple steady state modelling may introduce.

The work described here then involves two main elements. Firstly, the inter-model comparisons of the 'simple' and 'complex' simulation packages are described as applied to two example RCDs. Secondly, the work then goes on to compare the predicted performance of the two RCDs in their 'standard' and 'as built' forms.

RCD SELECTION

Although nineteen RCD cases were modelled in the overall study, for the purposes of this paper two cases have been chosen to exemplify the issues concerned.

One RCD exemplifies the surface condensation risk analysis and the other the interstitial condensation risk analysis. Details of the two RCDs are provided below.

RCD 6.18

RCD 6.18 has been selected for the surface condensation risk analysis in this paper as it was identified as being one of details particularly prone to difficulties in construction on site. This detail represents a timber intermediate floor constructed using cassettes manufactured off site. Observations at construction sites indicated that typically it appeared that no insulation (MI) was introduced at the manufacturing stage. After the cassettes have been installed the introduction of insulation is even less probable. The result would be that there is no insulation in the void between the two outermost joists running parallel with the external wall. Figure 1 shows both the ‘standard’ construction detail, as defined in the Robust Detail document, and also the ‘as built’ detail as observed at the surveyed construction sites.

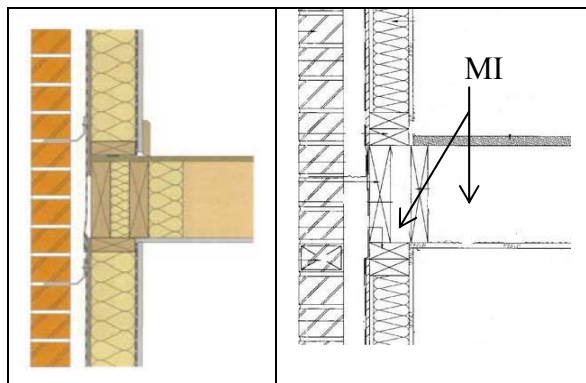

Figure 1. Robust Detail 6.18: (a) ‘standard’ detail, (b) ‘as built’; MI-missing insulation

RCD 6.12

RCD 6.12 has been selected for interstitial condensation risk analysis. This detail represents a timber frame construction with insulation below the slab. Despite the quality benefit that off site manufacture is able to achieve, problems can arise at the interface between site construction and pre-manufactured components. This is primarily a problem of ensuring acceptable tolerances, particularly in site based construction. For example, the timber frame wall panels were observed to be typically placed on floor slabs which were not level. In some cases the observed gaps under the timber frame were up to 30 mm. The significance of such gaps lies in the potential created for reduced airtightness and thermal performance, both of which will tend to result in local cooling of the floor slab and the space behind the skirting board with increased risk of surface and interstitial condensation.

Figure 2 shows both the ‘standard’ construction detail as defined the RCD document, and also the ‘as built’ detail as observed at the surveyed construction sites.

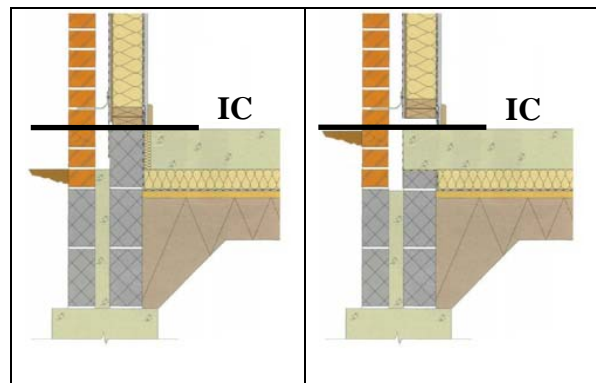

Figure 2. Robust Detail 6.12: (a) ‘standard’ detail, (b) ‘as built’ (IC marks the one dimensional cross-section modelled)

SIMULATION MODELS

Surface Condensation Models

Two thermal analysis software packages were used for surface condensation prediction – one ‘simple’ and the other more ‘complex’. The first, TRISCO (PHYSIBEL, 2004a), is based on the simple *steady-state* method of calculation defined in BS EN ISO 13788: 2002. For the *transient* analyses VOLTRA was used (PHYSIBEL, 2004b). VOLTRA is simply a transient version of TRISCO; the two models are otherwise identical.

For both models a non-uniform Cartesian coordinate system was set up using 34,200 nodes. The modelling procedures satisfied the validation criteria given in Annex A of BS EN ISO 10211-1:1996 including the grid independence criteria. The details were modelled in 2D for clarity.

An internal surface thermal resistance of 0.25 m²K/W, and external of 0.04 m²K/W were used for each surface as recommended in the Standard. The critical surface humidity was calculated for two different regimes of boundary conditions: (a) the internal, T_i , and external, T_e , temperatures were kept constant (in this study they were set at 20 °C and 0 °C) and the internal RH was kept constant at 50% and (b) the monthly mean external temperature, T_e , and relative humidity, ϕ_e , were defined in addition to the internal vapour pressure excess, Δp_{sat} , for the selected humidity class of the building. The humidity classes, which define the internal humidity load, were derived from BSI (2002a). Both the ‘standard’ version and the ‘as built’ version of the details were modelled.

For the transient modelling using VOLTRA a transient temperature profile was assumed, which

represented a family coming home to a cold property and turning on the heating, resulting in a rapid air temperature change from 10 to 20 °C over one hour. During this temperature rise, for clarity, it is assumed that the RH remains constant at 50 %, i.e. there is an increase in the moisture content of the air as would be the case if the family started cooking when they come home. The results were obtained using a time-step of 10 minutes over a 4 day period.

Interstitial Condensation Models

Again, two packages were used for the interstitial condensation analysis - one 'simple' and the other more 'complex'. These models were GLASTA and WUFI respectively.

GLASTA (PHYSIBEL, 2004c) is based on the simple *steady-state* method of calculation defined in the BS EN ISO 13788: 2002 and calculates the temperature, saturation vapour pressure and the vapour pressure in each interface for each period of time as prescribed by the standard. The Glaser method simplifies the physics of moisture and heat transport through the building envelope by assuming the following:

- a) condensation only occurs at the interface between material layers and remains at that interface
- b) thermal conductivity is independent of the moisture content of the material
- c) capillary suction and liquid moisture transfer does not occur in the building fabric
- d) there is no moisture transfer by convection within the structure of the detail
- e) monthly averaged boundary conditions are only used, i.e. the real boundary conditions are not constant over month
- f) only one dimensional heat and moisture transfer
- g) no solar radiation or driving rain.

WUFI (IBP, 2004) is a *transient* method and addresses all of the above limitations of the Glaser method. However, its increased complexity requires transient boundary conditions and more thermo-physical material data such as: (a) moisture dependent diffusion resistance factor, μ [-], which defines by how much the diffusion resistance of the material is higher than that of stagnant air, (b) liquid transport coefficient for suction, D_{ws} [m^2/s], and redistribution, D_{ww} [m^2/s], which is normally strongly dependent on the moisture content, (c) moisture dependent heat conductivity, λ [W/mK], (d) and moisture storage function, w [kg/m^3], defined for a porous hygroscopic materials, represents accumulation of water molecules in pores until a specific equilibrium moisture content corresponding to the humidity of ambient air is reached. All values

used in this study were taken from the WUFI material database (IBP, 2004).

Transient (hourly) boundary conditions were defined using the following parameters: (a) outdoor and indoor temperature, θ [$^{\circ}C$], (b) outdoor and indoor relative humidity, RH [%], (c) vertical incidence of rain load on the exterior surface, often referred to as "driving rain" [l/m^2h], and (d) incident solar radiation on a vertical exterior surface [W/m^2]. Since barometric pressure has only a minor effect on the calculation, the specification of a mean barometric pressure was taken to be sufficient (BSI, 2002b).

External boundary conditions for the transient complex analysis were determined from a meteorological Test Reference Year for Kew (west of London, UK) because no 'Moisture Design Reference Year' is available for the UK. Hourly internal boundary conditions were generated using the building simulation software 'Energy Plus' (USDOE, 2004) with the monthly average values being equal to those in the standard BS 5250: Code of practice for control of condensation in buildings (IBP, 2004), and used in the steady state, GLASTA simulation.

Both the GLASTA and WUFI models were one-dimensional and the relevant one-dimensional 'slice' is shown in Figure 2, marked as 'IC'.

SUMMARY OF METHODOLOGY

To summarise, the surface and interstitial condensation risks have been assessed using both 'simple' and 'complex' modelling techniques. Whilst the simple calculation methods are based on the assumption of steady state processes, the complex calculation methods assume transient processes. In the case of the interstitial condensation risk solar radiation and driving rain are also considered. The methodology applied in this paper is summarised in Table 1.

Table 1.
Summary of methodology

CONDENSATION	SIMPLE	COMPLEX
Surface	TRISCO	VOLTRA
Interstitial	GLASTA	WUFI

RESULTS AND DISCUSSION

Inter-model comparisons

Note that, for clarity, the inter-model comparisons only consider the 'standard' construction details

Surface Condensation Risk (RCD 6.18)

Using the 'simple' steady state TRISCO model and assuming constant internal conditions ($T_{ext} = 0$ °C,

$T_{int}= 20\text{ }^{\circ}\text{C}$, $RH_{int}=50\%$); the surface temperature at the floor/wall corner is predicted to be $15.6\text{ }^{\circ}\text{C}$ - the surface RH at the same position is predicted to be 65%. Therefore, for these boundary conditions, the simple method predicts ‘no risk of mould growth’, i.e. the RH at no time exceeds 80% (BSI, 2002b).

Now using the same ‘simple’ model but this time using monthly averaged environmental conditions (as defined in BS EN ISO 13788: 2002), results in the predicted surface conditions as given in Table 2. Again, no predictions over 80% are reported.

Thus the ‘simple’ model again predicts ‘no risk of mould growth’.

Table 2.
RCD 6.18 - Temperature and RH

Month	Outdoor Air		Indoor Air		Surface conditions	
	T [°C]	RH [%]	T [°C]	RH [%]	T [°C]	RH [%]
Jan	2.8	92	20	62	16.5	77
Feb	2.8	88	20	61	16.5	75
Mar	4.5	85	20	60	16.8	73
Apr	6.7	80	20	59	17.3	69
May	9.8	78	20	60	17.9	68
Jun	12.6	80	20	64	18.5	70
July	14.0	82	20	68	18.8	73
Aug	13.7	84	20	68	18.7	74
Sep	11.5	87	20	67	18.3	74
Oct	9.0	89	20	65	17.8	74
Nov	5.0	91	20	63	16.9	76
Dec	3.5	92	20	62	16.6	76

If one now turns to the more ‘complex’ transient model, Figure 3 shows the predicted internal surface temperatures during the ramped change in internal temperature. The predicted surface relative humidity is shown in Figure 4. Note that different time scales have been used in Figures 3 and 4. The calculated relative humidity at the corner of the ‘standard’ detail starts at 54% and rises rapidly to over 90%. It remains above the threshold value of 80% for several hours. This is a significant issue as the impact of having surface RHs above 80% for several hours is potentially important for mould growth.

So, we now have a case where, even though the internal and external conditions are the same as those used for the first steady state simulation, we have very different *transient* surface conditions for the period until which equilibrium is attained.

Thus, it is clear that potentially significant differences in the predictions of the ‘simple’ and ‘complex’ models are possible.

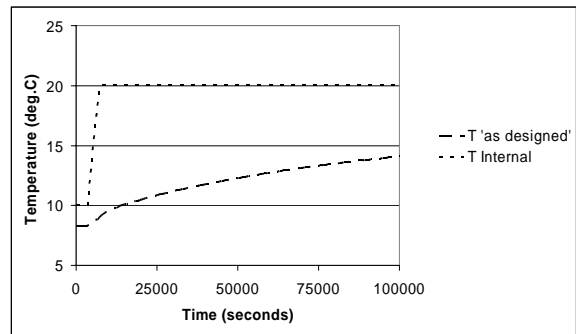

Figure 3. Predicted internal surface temperatures for the ‘standard’ RCD.

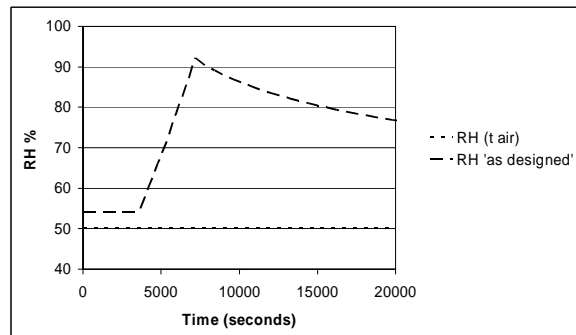

Figure 4. Predicted surface RH for the ‘standard’ RCD.

Interstitial Condensation Risk (RCD 6.12)

In the case of the ‘standard’ detail, the ‘simple’ GLASTA tool predicts no formation of condensate throughout the tested year for Robust Detail 6.12.

A ‘complex’, WUFI simulation was also carried out on the same element, using a transient external weather file and internal conditions. Figure 5 shows the moisture content at the plaster board of the ‘standard’ construction.

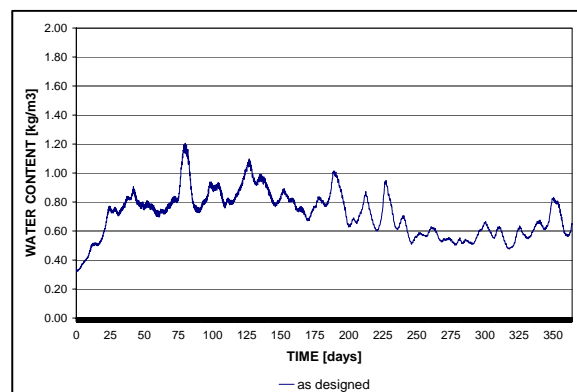

Figure 5. Moisture content predicted at the plaster board for ‘standard’ robust detail

It must be stressed that the complex methods allow for the effect of moisture absorption of the hygroscopic materials, moisture redistribution due to liquid transfer, solar radiation and driving rain to be taken into account, therefore different results in the prediction of risk of interstitial condensation, were expected.

The ‘simple’ method then predicted no formation of condensate throughout the year, whilst the ‘complex’ method predicted a peak amount of condensate of 1.2 kg/m³. The potential for discrepancies between the two methods is thus demonstrated. The significance of any such difference would depend on the specific RCD concerned and the path that any condensate might take.

Comparisons of ‘standard’ and ‘as built’ performance

Surface Condensation Risk (RCD 6.18)

Figure 6 shows the steady-state temperature profiles of the ‘as built’ version of the Robust Detail as predicted by the TRISCO model. As expected, the lowest temperature was predicted at the corner of the detail. The surface temperatures at the corner were 15.6 °C for the ‘standard’ version, and 14.1 °C for the ‘as built’ version of the detail. The ‘simple’ steady state calculated RHs were below 80% in both cases (65% and 72% respectively), assuming constant internal conditions ($T_{ext}=0\text{ °C}$, $T_{int}=20\text{ °C}$, $RH_{int}=50\%$); therefore for these boundary conditions, the simple method predicts no risk of mould growth in both cases. However, surface RH calculated assuming an average occupancy and using monthly averaged environmental conditions, as defined in the BS EN ISO 13788: 2002, exceeds 80% in both January and February for the ‘as built’ construction. The results summary for this case is given in Table 3.

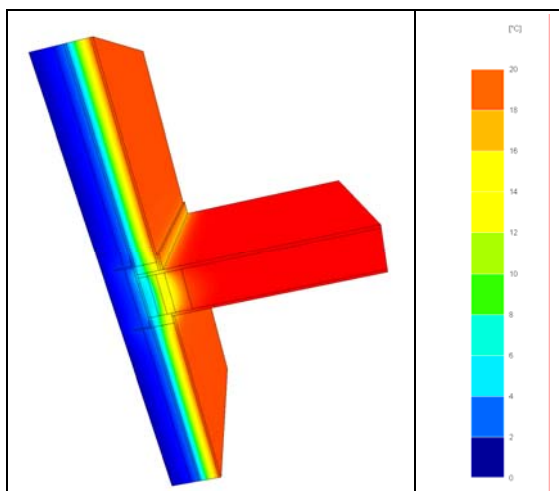

Figure 6. Steady-state temperature profile of the ‘as built’ robust detail

Table 3. RCD 6.18 - Temperature and RH

Month	Outdoor Air		Indoor Air		‘Standard’ surface conditions		‘As built’ surface conditions	
	T [°C]	RH [%]	T [°C]	RH [%]	T [°C]	RH [%]	T [°C]	RH [%]
Jan	2.8	92	20	62	16.5	77	15.0	84
Feb	2.8	88	20	61	16.5	75	15.0	83
Mar	4.5	85	20	60	16.8	73	15.5	79
Apr	6.7	80	20	59	17.3	69	16.1	75
May	9.8	78	20	60	17.9	68	17.0	72
Jun	12.6	80	20	64	18.5	70	17.8	73
July	14.0	82	20	68	18.8	73	18.2	76
Aug	13.7	84	20	68	18.7	74	18.2	76
Sep	11.5	87	20	67	18.3	74	17.5	78
Oct	9.0	89	20	65	17.8	74	16.8	74
Nov	5.0	91	20	63	16.9	76	15.6	76
Dec	3.5	92	20	62	16.6	76	15.2	76

Turning to the transient analyses now, Figure 7 compares the calculated internal surface temperatures during a ramped change in internal temperature. As expected, the internal surfaces of the ‘standard’ RCD respond more slowly to change in internal temperature than in the ‘as built’ case. The calculated relative humidity for both the versions of the RCD is shown in Figure 8. The calculated relative humidity at the corner of the ‘standard’ detail starts at 54% and rises rapidly to over 90% compared to the ‘as built’ of 58% and 95%. It remains above the threshold value of 80% for several hours in both cases. Large differences between the performances of the two details are not apparent although there the surface RH of the ‘as built’ detail is always higher than that of the ‘standard’ detail.

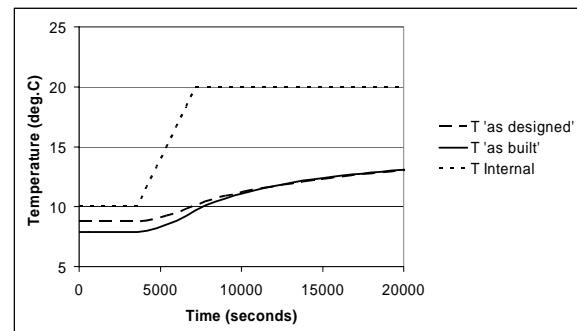

Figure 7. Comparison of internal surface temperature

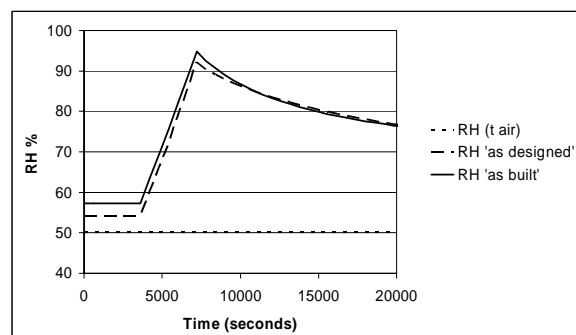

Figure 8. Comparison of predicted surface RH

Interstitial Condensation Risk (RCD 6.12)

As noted earlier, in the case of the 'standard' detail, the Glaser method predicts no interstitial condensation for RCD 6.12. In the case of the 'as built' construction, interstitial condensation, is predicted by Glaser method, between the vapour control layer and plaster board.

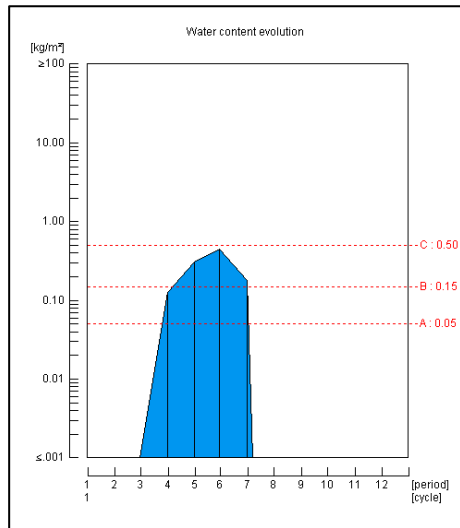

Figure 9. Cumulative diagram of interstitial condensation for 'as built' robust detail (NB: Month 1 is October)

Condensation formation starts in December (see Figure 9, period 3) reaches a peak in March (period 6), but then has all evaporated by the end of April (period 7). The calculated quantity of condensation, 0.45 kg/m^2 , exceeds the allowed water content for vegetable fibre construction material (A: 0.05 kg/m^2) with no waterproof glues (PHYSIBEL, 2004c). Although all condensate dries out in the period from March to April, and as such this 'as built' detail is in compliance with BS 13788: 2001, the risk of degradation of building materials and deterioration of thermal performance as a consequence of the calculated maximum amount of moisture should be considered. Note that in this case the vapour control layer was assumed to be in place and not damaged.

A complex, WUFI, simulation was also carried out on the same RCD, using a transient external weather file and internal conditions. Figure 10 compares the moisture content in the sheathing board of both the 'standard' and 'as built' constructions. Note that the highest differences in values of predicted moisture content were observed in the period from late October until late March (see Figure 10, day 25-180).

The difference in results between the 'standard' and 'as built' robust details leads to conclusion that the effect of workmanship on interstitial condensation

may be a significant issue. Note that a deterioration in the hygrothermal performance of the 'as built' RCD has been predicted by both the 'simple' and 'complex' models. However, both constructions would satisfy the current BS 13788: 2002 standard regarding interstitial condensation.

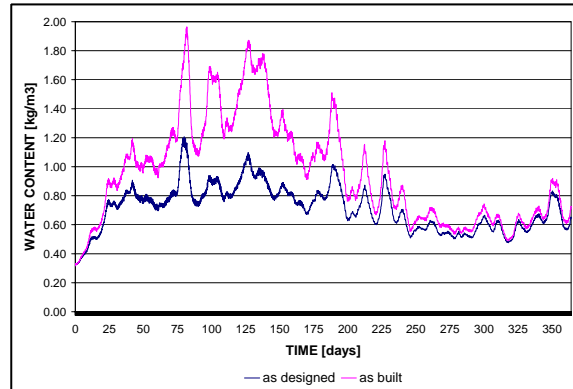

Figure 10. Comparison of moisture content predicted in sheathing board for 'standard' and 'as built' RCD (NB: Day 1 is October 1st)

In the case of transient interstitial condensation risk modelling it must be stressed that the purpose of this study was to compare the hygrothermal performance of 'standard' and 'as built' RCD and not to develop a test reference year for complex moisture calculations which currently does not exist for the UK. However, as the complex methods allow the effect of solar radiation and driving rain to be taken into account, the 'test reference year', based on Kew meteorological data, has been developed as described above. The hygrothermal performance of the 'standard' and 'as built' RCD strongly depend on the amount of rainfall and the solar radiation, therefore the predicted water content in the plaster board should be used to assess the influence of workmanship on the hygrothermal performance of the 'as built' RCD rather than to use the results as an accurate prediction of moisture conditions within the structure under service conditions at the specific location within the UK.

CONCLUSIONS

Let us first address the 'inter-model' issues. The current Standard used for the assessment of condensation risk and mould growth in the UK is based on the assumption of steady-state conditions inside and outside of buildings, neglecting the fluctuation of environmental conditions on a daily basis. In order to address the limitations of the current Standard this paper has modelled the surface and interstitial relative humidity of selected RCDs using both 'simple' steady state and 'complex' transient models. A quantitative indication of the types of uncertainties which simple steady state modelling may introduce was thus possible.

Significant differences in the predictions of the two approaches were found.

In the case of surface condensation, considering only the 'standard' RCD for clarity, significant differences are apparent between the predictions of the 'simple' and 'complex' methods for the boundary conditions considered. The complex method predicts several hours above 80% RH (the point at which surface mould growth may become problematic) on the internal surface of the robust details. The simple method however, predicts surface RH values below 80% for both the case when the internal RH was kept constant at 50% and also for when the external and internal environmental condition were defined on a monthly basis.

In the case of interstitial condensation it was shown that the two calculation methods can provide different results in the prediction of risk of interstitial condensation when driving rain is considered in the complex method. As the test reference year has not been defined yet for the UK, the results obtained should be used to provide an indication of performance rather than as an accurate prediction tool for a specific location. However, it is suitable for comparing different constructions and assessing the general impact of workmanship on the hygrothermal performance of RCDs.

Let us now move to the comparison of the predicted performance of the 'standard' and the 'as built' constructions. In the case of surface condensation, significant differences in the predictions of surface temperatures were observed using the *steady-state* model although the predicted surface RH values were all significantly below 80%.

Using the *transient* model, large differences in the thermal response of the 'standard' and 'as built' RCD were not observed although the surface RH of the 'as built' detail was always predicted to be higher than that of the 'standard' detail.

In the case of interstitial condensation, it was shown that the influence of workmanship on the moisture performance of both the 'standard' and 'as built' constructions is apparent – this was confirmed by both the 'simple' steady-state and more 'complex' transient methods.

The work reported here has focussed on two RCDs to exemplify the issues concerned. However, the work is part of a larger study which has examined the surface and interstitial condensation risk of *nineteen* RCDs in both their 'standard' and 'as built' forms. This substantial body of work will be further analysed and reported at a later date.

ACKNOWLEDGEMENTS

This work was funded by the UK Government's Building Regulations Research Programme.

REFERENCES

- Bell, M., Smith, M., Miles-Shenton, D. (2004) Condensation Risk – Impact of Improvements to Part L and Robust Details on Part C. Interim Report Number 6 – Draft fieldwork report. A Report to the ODPM Building Regulations Division Under the Building Operational Performance Framework. Project Reference Number CI 71/6/16 (BD2414), Leeds Metropolitan University.
- BSI (2002a) BS EN ISO 13788:2002 Hygrothermal performance of building components and building elements - Internal surface temperature to avoid critical surface humidity and interstitial condensation - Calculation methods, BSI, London
- BSI (2002b) BS 5250: 2002 Code of practice for control of condensation in buildings, BSI, London
- DTLR (2002) Limiting thermal bridging and air leakage: Robust construction details for dwellings and similar buildings, Norwich, TSO
- IBP (2004) WUFI Version 2.2 , http://www.hoki.ibp.fhg.de/wufi/intro_e.html Wufi Fraunhofer Institute of Building Physics, Germany, [Accessed 26 February 2004].
- PHYSIBEL (2004a) TRISCO Version 10.0w, <http://www.physibel.be/v0n2tr.htm> Physibel Software, Belgium, [Accessed 26 February 2004].
- PHYSIBEL (2004b) VOLTRA Version 4.0w, <http://www.physibel.be/v0n2vo.htm> Physibel Software, Belgium, [Accessed 26 February 2004].
- PHYSIBEL (2004c) GLASTA Version 5.0w <http://www.physibel.be/v0n2gl.htm> Physibel Software, Heirweg 21, B-9990 Maldegem, Belgium, [Accessed 26 February 2004].
- Sanders, C. (2003) Advanced calculations of moisture in structures cc2073 Building Research Establishment, East Kilbride, Scotland.
- US DoE (2004) Energy Plus <http://www.eere.energy.gov/buildings/energyplus> U.S. Department of Energy, [Accessed 26 February 2004].