

Jones, A. & Forster, B. (2013). Independent effects of endogenous and exogenous attention in touch. *Somatosensory and Motor Research*, 30(4), pp. 161-166. doi: 10.3109/08990220.2013.779243



**CITY UNIVERSITY
LONDON**

[City Research Online](#)

Original citation: Jones, A. & Forster, B. (2013). Independent effects of endogenous and exogenous attention in touch. *Somatosensory and Motor Research*, 30(4), pp. 161-166. doi: 10.3109/08990220.2013.779243

Permanent City Research Online URL: <http://openaccess.city.ac.uk/4561/>

Copyright & reuse

City University London has developed City Research Online so that its users may access the research outputs of City University London's staff. Copyright © and Moral Rights for this paper are retained by the individual author(s) and/ or other copyright holders. All material in City Research Online is checked for eligibility for copyright before being made available in the live archive. URLs from City Research Online may be freely distributed and linked to from other web pages.

Versions of research

The version in City Research Online may differ from the final published version. Users are advised to check the Permanent City Research Online URL above for the status of the paper.

Enquiries

If you have any enquiries about any aspect of City Research Online, or if you wish to make contact with the author(s) of this paper, please email the team at publications@city.ac.uk.

Cite as: Jones, A. & Forster, B (in press). Independent effects of endogenous and exogenous attention in touch. *Somatosensory and Motor Research*, doi:10.3109/08990220.2013.779243

Title: Independent effects of endogenous and exogenous attention in touch

Alexander Jones¹²³ & Bettina Forster³

¹Université Paris Descartes, Sorbonne Paris Cité, Paris, France

²CNRS (Laboratoire Psychologie de la Perception, UMR 8158), Paris, France

³City University London, UK

First and corresponding author address:

Alexander Jones
Laboratoire Psychologie de la Perception
Université Paris Descartes
45 rue des Sts Pères
75270 Paris Cedex 06, France

Tel : +33(0)142862198

Fax : +33(0)142863322

Email: alexander.jones.1@city.ac.uk

Number of pages: 12

Number of figures: 2

Keywords: Tactile, Attention, Endogenous, Exogenous, Independent mechanisms.

Introduction

Mechanisms of selective attention help us to focus on information of behavioural relevance from the stream of incoming information from our senses. Attention research distinguishes between reflexive (exogenous) and voluntary (endogenous) orienting of attention and a commonly used paradigm to investigate these types of attention was developed by Posner (1980). Typically in such a cue-target paradigm endogenous attention would be induced by an informative central cue indicating the most likely location for an upcoming peripheral target. Endogenous orienting generally leads to enhanced processing for targets at attended locations with facilitation of response times (RTs) (e.g., Müller & Rabbitt, 1989; Cohen, Bolanowski, & Verrillo, 2005). Exogenous orienting in a Posner paradigm would be induced by presenting non-informative peripheral cues. That is, a cue to the left or right will not give any indication of where the target is likely to appear. Although the cue in an exogenous paradigm is instructed to be ignored, it may have an effect on target processing, both by facilitation as well as inhibition (Miles, Poliakoff, & Brown, 2008). That is, when the target appears at the same side as the cue it can facilitate response times (e.g., Spence & McGlone, 2001) but also inhibit response times, known as inhibition of return (IOR; Klein, 2000; Posner & Cohen, 1984). IOR, a phenomenon which is slowed responses to previously cued locations compared to novel locations, is demonstrated when there is a longer stimulus onset asynchrony (SOA) between cue and target (approximately 300 ms in vision). The most popular conceptualization of the IOR effect is the reorienting hypothesis (e.g., Posner et al., 1985). This suggests attention is first drawn towards a stimulus. Once attention is disengaged IOR acts as a mechanism inhibiting attention to return to previously explored location, and thereby saving attentional resources (although see Berlucchi, 2006, and Lupianez, 2010 for a review of alternative views on what mechanisms underlie IOR).

Everyday situations often require activating and combining both endogenous and exogenous attention. For example, when driving, our endogenous attention is focused upon the road ahead, whilst we still need to be able to process unexpected events such as an approaching car from another direction, in other words, also be receptive to exogenous stimuli. Although the majority of studies have considered endogenous and exogenous attention in isolation, some studies have investigated how these two mechanisms are related. (Berger et al., 2005; van der Lubbe & Postma, 2005; Müller & Rabbitt, 1989; Theeuwes, 1991; Yantis & Jonides, 1990). Much of this research has explored the effects of how exogenous stimuli can capture our attention when endogenous attention is focused elsewhere. There has been empirical support for both the view that exogenous stimuli has an impact when our attention is otherwise engaged (e.g. van der Lubbe & Postma, 2005) and the contrary suggesting stimuli outside the focus of attention does not attract attention (Yantis & Jonides, 1990; Theeuwes, 1991).

In a series of experiments, using a range of SOAs, Berger et al, (2005) aimed to further establish whether endogenous and exogenous attention mechanisms are separate or if they interact. Berger and colleagues employed a ‘double-cueing paradigm’ where endogenous and exogenous attention are manipulated (cued) in the same trial. In three experiments they also found faster RTs for endogenous attended compared to unattended trials. Moreover, they demonstrated effects of exogenous cueing. There was facilitation for exogenously cued compared to uncued targets at short SOAs (0 ms, 100 ms). At longer SOA (750 ms) the pattern was reversed and exogenously cued targets resulted in IOR. Importantly, they found no interaction between endogenous and exogenous attention, even though at long SOA the two mechanisms accounted for opposite effects. In other words, the effect of exogenous attention (e.g., IOR at long SOA) was the same regardless of whether the target appeared at an endogenously attended or unattended location. This indicated that exogenous and endogenous attention mechanisms can independently have effects upon behaviour without interacting. To investigate whether endogenous and exogenous attention interact during more demanding conditions, Berger and colleagues increased the task difficulty and participants performed target discrimination rather than simple target detection. In this fourth experiment they found an interaction between endogenous and exogenous attention but only at intermediate SOA (300 ms), there was still main effects of exogenous and endogenous facilitation at earlier SOAs (100 ms and 200 ms). The interaction consisted of an effect of exogenous facilitation when targets were endogenously attended compared to no exogenous effect for endogenously unattended stimuli. Based on their series of experiments Berger et al. (2005) proposed that “... endogenous and exogenous orienting are separate mechanisms that, under low task demand, can lead to independent orienting effects, even under conditions when they contradict each other. Increasing task demands leads to an interaction between the mechanisms as they compete for shared resources” (p. 219).

Evidence that endogenous and exogenous attention are mechanisms operating separately also comes from neuroimaging studies. For example, in a double-cueing paradigm study with endogenous and exogenous cues in the same trial, Natale, Marzi, Girelli, Pavone, and Pollmann (2006) demonstrated faster RTs for exogenous cued compared to uncued targets. They concurrently measured fMRI activation and found the ventral fronto-parietal (vFP) areas to be activated in relation to unattended endogenous targets whilst the exogenous cues did not modulate this activity. Although the neural correlates of exogenous and endogenous attention and how they interact are not fully established, the activation of different brain areas suggest some segregation between the orienting systems in vision (see Corbetta & Shulman, 2002; and Macaluso, 2010, for reviews of the neural correlates of endogenous and exogenous attention).

While the majority of experimental studies on spatial attention have been conducted in the visual modality, comparably few studies have investigated tactile attentional selection (see Johansen-Berg &

Lloyd, 2000; and Spence & Gallace, 2007, for reviews of tactile attention studies). Furthermore, most studies investigating tactile attention have not controlled for visual orienting effects on tactile processing. A number of tactile attention studies have used visual cues to direct attention to tactile targets (Chica et al., 2007; Forster & Eimer, 2005; Posner, 1978; Spence, Pavani, & Driver, 2000) inducing crossmodal orienting effects (Chica et al., 2007; Mondor & Amirault, 1998; Turatto, Benso, Galfano, & Umiltà, 2002), while in other studies (e.g., Cohen et al., 2005; Lloyd et al., 1999) participants moved their eyes to the tactile target location inducing visual overt orienting effects (Rorden, Greene, Sasine, & Baylis, 2002). Other cross-modal paradigms have investigated the automaticity of exogenous tactile stimuli by varying visual perceptual load. For example, Santangelo and Spence (2007) showed that increasing the visual perceptual load in a central task led to reduced influence of peripheral tactile stimuli. Thus, suggesting a higher focused state in a visual task leads to filtering out irrelevant tactile stimuli. Similar findings have also recently been demonstrated using EEG whereby the neural correlates of exogenous tactile stimuli were attenuated during visual engagement (Jones & Forster, in press). To understand the operations of tactile attentional mechanisms and to clarify whether attentional mechanisms are modality specific or operate in the same fashion across modalities, tactile attention studies employing modality specific paradigms (e.g., employing tactile cues and targets) and excluding engagement of other modalities (e.g., vision) are required. Endogenous and exogenous attention has been researched with purely tactile cues and targets and IOR has been demonstrated in touch (Cohen, et al., 2005; Lloyd et al., 1999; Poliakoff et al., 2002; Röder, Spence, & Rösler, 2002; Röder, Spence, & Rösler, 2000, Jones & Forster, 2012). However, different to vision, no early facilitation period has, to the authors' knowledge, been demonstrated using simple target detection. Lloyd et al (1999) demonstrated IOR at a SOA as short as 100 ms. Tactile discrimination tasks however, show a similar behavioural pattern to what is demonstrated in vision. In vision, a biphasic early facilitation and late IOR is present also when discriminating between targets but IOR occurs later compared to in a detection task, around 500-600 ms SOA (Lupianez et al., 1997). Investigating the tactile modality, Miles and colleagues used a task where participants ignored exogenous tactile cues and discriminated between high and low frequency vibration targets (Miles et al., 2008; Brown et al., 2010). They found, similarly to the behavioural pattern in vision, facilitation at early SOAs (150 and 350 ms), no effect at intermediate (550 ms), and IOR at longer cue-target interval (1000 ms). Exogenous cueing in vision and touch have thus shown both similar (discrimination task) as well as different (detection task) behavioural patterns.

Several studies using visual stimuli have suggested that exogenous and endogenous mechanisms operate independently. However, it is not clear whether the same is true for the tactile sense. Touch is qualitatively different from other modalities in that it is a proximal sense, making it more difficult to "shut out" exogenous stimuli. If however, endogenous and exogenous attention behave similarly in the tactile modality then this would argue in favour of a more supramodal account of attention (Farah,

Wong, Monheit, & Morrow, 1989). To our knowledge, the interaction of endogenous and exogenous attention has not been investigated using a double cueing paradigm where both types of orienting are manipulated in the same trial. Moreover, we aimed to explore whether endogenous attention influenced exogenous facilitation and IOR differently. It has recently been suggested that IOR is not synonymous with exogenous attention (Fuchs & Ansorge, 2012). That is, increasing amount of research suggests IOR cannot be explained using an attention account, and thus, not an exogenous attention phenomenon (see Lupianez, 2010, for a review on this issue). By manipulating endogenous and exogenous attention in the same trial we aimed to test whether endogenous attention influenced exogenous facilitation and/or IOR, and whether IOR and exogenous attention should be viewed as two sides of the same coin or as separate mechanisms. To induce endogenous attention we used bilateral tactile cues directing attention to the left or right. Prior to the target, an exogenous tap appeared either to the same or opposite side as the target. Based upon Miles and colleagues (Brown et al., 2010; Miles et al., 2008), who demonstrated that tactile discrimination tasks show facilitation at short SOAs (see also Spence & McGlone, 2001) and IOR at longer SOAs, we used a range of SOA with the aim to elicit both effects and potentially an interaction (see Berger et al., 2005). Taken together, the study objectives were firstly, to establish whether exogenous and endogenous attention interacts or independent mechanisms in touch. Secondly we were interested in investigating whether endogenous attention affected exogenous facilitation and IOR similarly which would shed light upon whether IOR is an attentional phenomenon. Specifically we predicted endogenous facilitation of response times. The pattern of exogenous results expected was facilitation for short SOA and IOR for the long SOA, and an interaction at intermediate SOA (550 ms and 850 ms). Moreover, if IOR is independent from exogenous orienting then we would expect IOR to be unaffected by the focus of endogenous attention whilst exogenous facilitation may still be influenced.

Methods

Participants

Data were collected from fourteen paid participants in Experiment 1 (7 male and 7 female), and fourteen paid participants in Experiment 2 (6 male and 8 female), all of whom were right-handed and naïve to the purpose of this study. Participants' age ranged from 20 to 42 years old, with a mean age of 25.3 years old. The experiment lasted approximately 60 minutes and all participants provided written informed consent.

Stimuli and materials

The apparatus and materials were identical in Experiment 1 and 2. Participants were seated in a sound attenuated room which was controlled for light, sound, and temperature. Tactile stimuli were presented using 12-V solenoids (5 mm in diameter), to the finger pad of the middle fingers and thumbs. The solenoids were set into two wooden cubes (63mm x 50mm), each with two tactile

stimulators (2.2 cm between solenoid's tips) for the middle finger and thumb of the left and right hand. The two cubes were fixated 640 mm apart on a foam mat (approximately 2 cm thick), used for participants' comfort and for reducing noise caused by the tactile stimulators if in direct contact with the table. The endogenous cue consisted of two different vibrations directing attention to the left or right. The two vibrations (cycles of switching solenoids ON/OFF) evoked a sensation of 'flutter' (5 cycles of 6 ms ON and 54 ms OFF followed by 2 ms ON) or 'continuous' (15 cycles of 2 ms ON and 18 ms OFF followed by 2 ms ON) vibrations each of a duration of 302 ms. The exogenous cue was a 50 ms tap presented simultaneously to both the thumb and middle finger of either the left or right hand. Target stimuli consisted of a rapid 25 ms buzz (5 cycles of ON 3 ms and OFF 2 ms) presented to one of the four possible locations, either up (fingers) or down (thumbs) to the left or right hand. Verbal responses were made into a centrally located microphone which recorded responses and RTs were logged using E-Prime. White noise (58 dB SPL) was continuously present through two speakers, each located in a direct line behind each cube, to mask any sounds made by the tactile stimulators. A black cloth was used to cover the participant's hands to deprive all visual information of the stimulated body location. Stimuli were presented and recorded using E-Prime. Participants were monitored via a video camera throughout the experiments for any head movements. As the microphone and recording system did not discriminate between different sounds, an intercom system was used so the experimenter could hear the participants responses, and in turn code up or down on a keyboard in the adjacent room.

Design and procedure

The design and procedure were identical in Experiment 1 and 2 with the exception that in Experiment 1, the SOA between exogenous cue and target was 250 ms and 850 ms, and in Experiment 2, 550 ms and 1350 ms¹. Each experiment consisted of three factors; SOA (Experiment 1; 250, 850 ms, Experiment 2; 550 ms, 1350 ms), Endogenous orienting (attended, unattended), and Exogenous orienting (cued, uncued). Each experiment consisted of two practice blocks of 40 trials each with 32 trials indicating the correct target location (attended trials) and on 8 trials cues were misleading (unattended trials). The practice blocks were followed by six experimental blocks of 80 trials each with 64 (p=.80) attended and 16 (p=.20) unattended trials. The exogenous cue was weighted 50/50 for cued and uncued. In half of the endogenous attended trials (32 trials) the exogenous cue was presented at the same side as the target, thus an endogenous attended and exogenous cued trial. In the other half of the endogenously attended trials the exogenous cue was presented to the opposite side to the target, thus endogenous attended and exogenous uncued trial. The exogenous cues were also equally

¹ The 250 ms SOA was largely based upon Spence and McGlone (2001) who demonstrated facilitation up to 400 ms using a similar discrimination task. Experiment 2 was added to establish whether the lack of IOR in the 850 ms condition in Experiment 1 was because the SOA was not long enough, or whether no IOR was present in this double-cueing paradigm. Thus, in Experiment 2 we included a SOA of 1350 ms which is well within the time range of when IOR would be expected in an exogenous tactile discrimination task (e.g., Miles et al., 2008)

weighted for unattended trials, and all stimuli were equally balanced between left and right. Further, on half of all trials the targets were presented to either the left or right middle finger (up), and the other half the targets to the thumbs (down). The endogenous cues were counterbalanced between participants' so continuous vibration indicated left and flutter vibration indicated right and vice versa for the other half of participants'. All trials were randomly presented in each block.

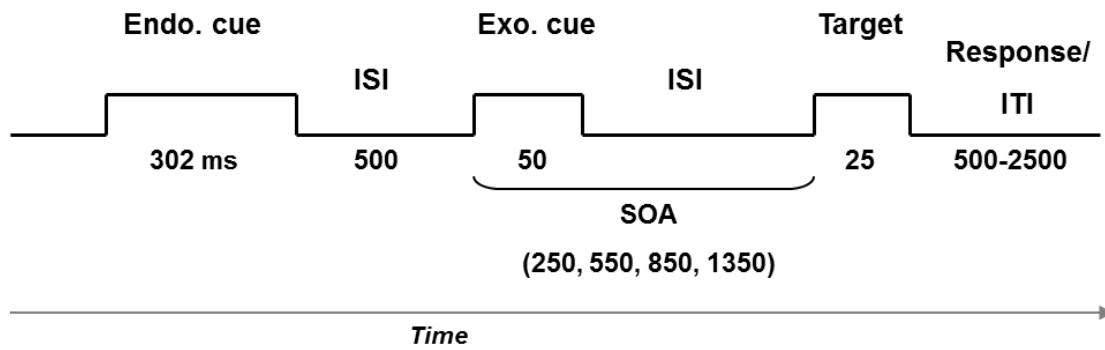

Figure 1 Stimuli presentation. Timeline in milliseconds of stimuli presentation during a typical trial: The endogenous cue (Endo. cue) was either a flutter or continuous vibration presented bilaterally. The exogenous cue (Exo. cue) was a single tap presented to both the thumb and middle finger of either the left or right hand. The target was a short buzz presented to the thumb or middle finger of the left or right hand. ISI = inter stimulus interval; SOA= stimulus onset asynchrony; ITI = inter trial interval.

Each trial started with one of two vibrations to all four stimulators indicating to which side the participant was to focus their endogenous attention. The endogenous cue was presented bilaterally. Participants' were instructed to focus their covert attention to the side indicated by the bilateral cue whilst fixating their gaze upon a centrally located cross. Following the off-set of the endogenous cue there was an inter-stimulus interval of 500 ms before the presentation of the unilateral exogenous cue (see Figure 1). The participant was informed that this exogenous cue (or distractor) was to be ignored and appeared at random, equally often to the right and left. Following the off-set of the exogenous cue there was a varied inter-stimulus interval of 200, 500, 800, or 1300 ms prior to the presentation of the target. The participant made a vocal discrimination, saying up if the target stimulus appeared to either middle finger, and down if the target was presented to either thumb. Via an intercom system, the experimenter then coded their response on a keyboard in the adjacent room. Following the experimenters key-press, there was a random inter-trial interval between a minimum of 500 ms and maximum of 2500 ms before the next trial started.

Results

The data from Experiment 1 and 2 were analysed using separate repeated-measures ANOVAs (a separate ANOVA was performed for each experiment as different participants completed Experiment

1 and 2). The factors included in the statistical analysis were Endogenous attention (attended, unattended), Exogenous attention (cued, uncued) and SOA (250 ms and 850 ms in Experiment 1; 550 ms and 1350 ms in Experiment 2). The SOA factor only refers to the time interval between exogenous cue and target. The time interval between endogenous and exogenous cue onset was always constant (802 ms, see Figure 1). Prior to analysis of main effects an error analysis was performed. Errors where participants did not respond were excluded. These errors were likely due to the microphone not recording a response. In Experiment 1 (SOA of 250 ms and 850 ms) less than 1% of trials were due to no responses and 2% of trials across all participants in Experiment 2 (SOA of 550 ms and 1350 ms). Further, discrimination errors, (e.g., participants responded up to a target presented to their thumb) accounted for less than 4% of trials across all participants in Experiment 1, and less than 6% in Experiment 2. RTs which were too slow or too fast were also filtered out. This was calculated individually for each participant where RTs greater than 1.96 standard deviations above or below the mean were excluded. This filter led to approximately 6% of trials excluded across all participants in Experiment 1, and approximately 14% of trials were excluded from subsequent analysis in Experiment 2.

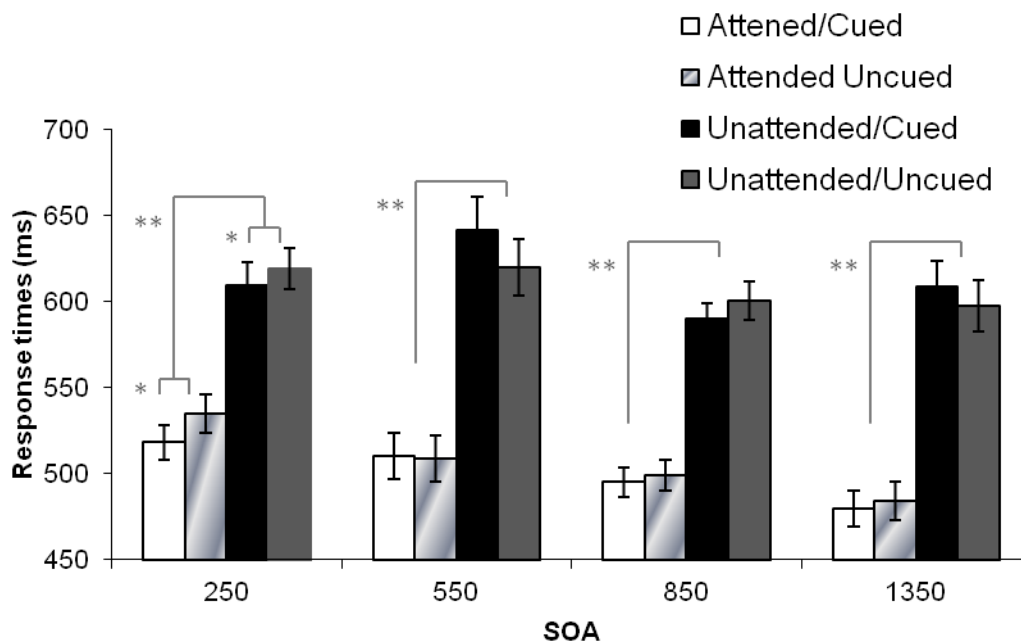

Figure 2 Response times (in milliseconds) to trials where targets were endogenously attended or unattended, and exogenously cued or uncued. Experiment 1 included stimulus onset asynchronies (SOAs) between exogenous cue and target of 250 ms and 850 ms, and Experiment 2 included SOAs of 550 ms and 1350 ms. The SOA only refers to the time interval between exogenous cue onset and target. The time interval between endogenous and exogenous cues was always constant (see Figure 1). Endogenous orienting to attended targets was significantly faster compared to unattended targets (** $p < .001$). There was a significant difference ($*p < .05$) between Exogenous cued and uncued trials, but only for SOA of 250 ms.

Table 1 Summary of response times (ms) for endogenous and exogenous attention conditions at each SOA.

SOA (ms)	<u>Endo. Attended</u>		<u>Endo. Unattended</u>	
	<u>Exo. cued</u>	<u>Exo. uncued</u>	<u>Exo. cued</u>	<u>Exo. uncued</u>
250	518.3	535.1	609.6	619.1
550	510.3	508.6	641.9	620.0
850	495.0	499.1	589.9	600.6
1350	479.7	484.5	608.7	597.3

Note: The SOA (stimulus onset asynchrony) refers to interval between endogenous and exogenous cue onset. Endo. = Endogenous, Exo. = Exogenous.

There were significant main effects of SOA and Endogenous orienting in both Experiment 1 and 2. In Experiment 1, responses to targets preceded by an 850 ms SOA (mean= 547.74 ms) were significantly faster compared to targets with a 250 ms SOA (mean = 571.53 ms) ($F(1,13)=8.09$, $p=.014$, $\eta^2_p=.38$). This effect was also present in Experiment 2 where responses to targets preceded by a 1350 ms SOA (mean = 542.53 ms) were significantly faster ($F(1,13)=10.01$, $p=.007$, $\eta^2_p=.44$) than responses to targets preceded by a 550 ms SOA (mean = 570.20 ms). Thus, the longer SOA in each experiment induced significantly faster RTs in relation to the shorter SOA (see Figure 2). A main effect of Endogenous orienting was significant in Experiment 1 ($F(1,13)=67.75$, $p<.001$, $\eta^2_p=.84$) as attended targets (mean = 512.69 ms) were significantly faster as compared to endogenously unattended targets (mean = 606.29 ms). Similarly, a significant main effect of Endogenous orienting was present in Experiment 2 ($F(1,13)=49.14$, $p<.001$, $\eta^2_p=.79$) as attended targets (mean = 495.78 ms) were on average 121 ms faster compared to unattended targets (mean = 616.95 ms).

Experiment 1 demonstrated a significant effect of Exogenous cueing ($F(1,13)=4.72$, $p=.049$, $\eta^2_p=.27$) with faster RTs for exogenously cued (553.16 ms) compared to uncued trials (565.82 ms). There was no overall significant effect of Exogenous cueing in Experiment 2 ($p=.68$, $\eta^2_p=.09$). Comparisons were also made for Endogenous and Exogenous effects at each SOA separately, as the a priori predictions suggested that facilitation and IOR may vary at short and long SOA. Analysis of the 250 ms SOA trials showed a significant effect of Exogenous attention ($F(1,13)=6.55$, $p=.024$, $\eta^2_p=.34$) suggesting facilitation of exogenous cued (563.30 ms) compared to uncued trials (579.78 ms). However, there was no Endogenous*Exogenous interaction ($p=.60$, $\eta^2_p=.02$) suggesting the facilitation effect was the same regardless if the target appeared at the attended or unattended side (see Figure 2). There were no effects of Exogenous cueing in the 550 ms ($p=.31$, $\eta^2_p=.08$), 850 ms ($p=.41$, $\eta^2_p=.05$), or 1350 ms ($p=.69$, $\eta^2_p=.01$), nor Exogenous*Endogenous interactions at any of the three

other SOAs (550 ms, $p=.34$, $\eta^2_p=.07$; 850 ms, $p=.54$, $\eta^2_p=.03$; or 1350 ms, $p=.14$, $\eta^2_p=.16$). Similar endogenous attention effects were present at all 4 SOAs ($p<.001$).

Discussion

The aims of the study were to firstly investigate the effects of endogenous and exogenous orienting in touch and if they interact or are separate mechanisms. Secondly we aimed to test whether endogenous attention affects exogenous facilitation and IOR similarly. The results demonstrated that bilateral cues induce endogenous orienting and facilitate RTs at the attended location. The endogenous facilitation effect was present at all SOAs between exogenous cue and target (250, 550, 850, & 1350 ms; see Figure 2 and Table 1) demonstrating a robust endogenous cueing effect over 2 seconds. However, the exogenous cue only influenced RTs when the SOA was short (250 ms). Moreover, there was no interaction between endogenous and exogenous attention effects suggesting these are separate mechanisms. In other words, the effect of exogenous attention seen at the 250 ms SOA condition was the same regardless if the target appeared at the endogenously attended or unattended location. At longer SOAs there was no effect of exogenous orienting, in particular no IOR. This suggests that endogenous attention does not have the same influence on exogenous facilitation and IOR, which supports recent claims that IOR and exogenous attention are separate mechanisms (e.g. Lupianez, 2010). Our results favour a supramodal account of attention, however, this supramodal account applies only to attentional effects of facilitation, and not IOR.

The lack of interaction between endogenous and exogenous attention is partly in line with a similar double cueing study using visual stimuli (see also van der Lubbe & Postma, 2005). Similar to the present results, Berger et al. (2005) found that endogenous orienting facilitated RTs at attended locations. Moreover, when there was a short SOA (100 ms) between the exogenous cue and target there was facilitation of exogenously cued targets. At longer SOA the participants' demonstrated IOR, with longer RTs for cued compared to uncued trials. Our results are only partly in line with Berger et al.'s (2005) findings as we did not demonstrate IOR effects at longer SOAs (this was surprising as previous tactile discrimination studies, investigating only exogenous attention, have found the biphasic pattern with early facilitation and late IOR effects, e.g., Miles et al, 2008). Moreover, Berger and colleagues proposed that a discrimination task increases task demands such that endogenous and exogenous attention interacts. However, it is possible that the discrimination task in the present study was not difficult enough to require endogenous and exogenous attention to interact. This simplicity may be indicated by the fact that the error rates were rather low, amounting to on average 5% of all trials. This is in line with the suggestion made by Berger et al. that when the task is simple (detection task in their study) the attentional resources are not exhausted and the two modes of orienting occur in separation, and they interfere only when task demands are higher. In other words, it is possible that

the present tactile discrimination task was too simple to elicit any interaction between endogenous and exogenous attention.

Conversely, there was no indication that the longer SOAs elicited IOR. In contrast to the hypothesis that the lack of interaction between endogenous and exogenous attention effects was a result of the task being too easy, it has been suggested that easier discrimination tasks allows for more IOR (Cheal & Chastain, 1999). Moreover, the absence of IOR influences at the longer SOA contrasts recent tactile discrimination studies of exogenous attention. Brown and colleagues (Brown et al., 2010; Miles et al., 2008) demonstrated facilitation at early SOAs (150 ms and 350 ms), no difference at 540 ms, and IOR at 1000 ms. The 1350 ms SOA between exogenous cue and target was well within the time range previously demonstrated to elicit IOR in an exogenous discrimination task. Several possible hypotheses could account for the lack of IOR effect. It could be that endogenously orienting towards a tactile location eliminates and masks any IOR. This would contrast Berger et al.'s (2005) conclusion that IOR is inexorable and not affected by endogenous attention. It may also be possible that endogenously attending delays the development of IOR beyond the longest SOA measured in the present study. In other words, in previous tactile exogenous discrimination tasks the IOR develops at around 1000 ms post cue onset (Brown et al., 2010; Miles et al., 2008). By including endogenous orienting in the task the additional attention resources required may delay the onset of IOR even further, however, this seems unlikely. A third possibility may be that endogenous attention is completely re-oriented during the time window between exogenous cue and target. Thus, the attention is initially drawn towards the exogenous cue. When the SOA is short (250 ms) there is not sufficient time for the endogenous attention to fully re-orient back to the attended location. This in turn leads to an effect of exogenous attention. At longer SOAs, the irrelevant cue may initially attract attention away from the endogenously attended location. However, there is sufficient time to fully re-orient covert endogenous attention back to the endogenously attended location, and eliminating any effects of exogenous attention. The pattern of exogenous results also sheds light on the relationship between IOR and exogenous attention. IOR has often been taken as a measure of exogenous attention. However, recent studies have suggested that IOR is not synonymous with exogenous attention (Fuchs & Ansorge, 2012). The fact that we find only effects of exogenous facilitation and not IOR further supports this notion that IOR may be a separate mechanism to exogenous attention.

In summary, our results suggest that endogenous and exogenous tactile attention are independent mechanisms, similar to what has been demonstrated in vision (e.g., Lupianez et al 2004, Berger et al, 2005). However, unlike previous studies of exogenous tactile attention we did not demonstrate effects of IOR at longer SOAs (e.g., Brown et al., 2010; Miles et al., 2008). This suggests that exogenous attention and IOR are not two sides of the same coin. All in all, the results are in line with a supramodal account of attention, however, this account does not extend to IOR.

Declaration of interest

The authors report no conflicts of interest. The authors alone are responsible for the content and writing of the paper.

References

- Berger, Andrea, Henik, Avishai, & Rafal, R. (2005). Competition between endogenous and exogenous orienting of visual attention. *Journal of experimental psychology. General*, 134(2), 207-21.
- Brown, R. J., Danquah, A. N., Miles, E., Holmes, E., & Poliakoff, E. (2010). Attention to the body in nonclinical somatoform dissociation depends on emotional state. *Journal of psychosomatic research*, 69(3), 249-57.
- Chica, A. B., Sanabria, D., Lupiáñez, J., & Spence, C. (2007). Comparing intramodal and crossmodal cuing in the endogenous orienting of spatial attention. *Experimental brain research*, 179(3), 353-64.
- Cohen, J. C., Bolanowski, S. J., & Verrillo, R. T. (2005). A direct comparison of exogenous and endogenous inhibition of return and selective attention mechanisms in the somatosensory system. *Somatosensory & motor research*, 22(4), 269-79.
- Corbetta, M., & Shulman, G. L. (2002). Control of goal-directed and stimulus-driven attention in the brain. *Nature review Neuroscience*, 3(3), 201-15.
- Farah, M. J., Wong, A. B., Monheit, M. A. & Morrow, L. A. (1989). Parietal lobe mechanisms of spatial attention: Modality-specific or supramodal? *Neuropsychologia*, 23(4), 461-470
- Forster, B., & Eimer, M. (2005). Covert attention in touch: behavioral and ERP evidence for costs and benefits. *Psychophysiology*, 42(2), 171-9.
- Fuchs, I., & Ansorge, U. (2012) Inhibition of return is no hallmark of exogenous capture by unconscious cues. *Frontiers in human neuroscience*, 6(30), 1-8
- Johansen-Berg H, Lloyd DM (2000). The physiology and psychology of selective attention to touch. *Frontiers in Bioscience*, 5, d894-904.
- Jones, A., & Forster, B. (2012) Reflexive attention in touch: An investigation of event related potentials and behavioural responses. *Biological Psychology*, 89, 313-322.

Cite as: Jones, A. & Forster, B (in press). Independent effects of endogenous and exogenous attention in touch. *Somatosensory and Motor Research*, doi:10.3109/08990220.2013.779243

Jones, A., & Forster, B. (in press). Lost in vision: ERP correlates of exogenous tactile attention when engaging in a visual task, *Neuropsychologia*. DOI:10.1016/j.neuropsychologia.2013.01.010

Lloyd, D. M., Bolanowski Jr, S. J., Howard, L., & McGlone, F. (1999). Mechanisms of attention in touch. *Somatosensory & Motor Research*, 16(1), 3-10.

van der Lubbe, R. H. J., & Postma, A. (2005). Interruption from irrelevant auditory and visual onsets even when attention is in a focused state. *Experimental brain research*, 164(4), 464-71.

Lupianez, J., 2010, Inhibition of return. In A. C. Nobre & J. T. Coull (Eds.), *Attention and time* (pp. 17-34). Oxford: Oxford University Press

Lupiáñez, J., Decaix, C., Siéoff, E., Chokron, S., Milliken, B. & Bartolomeo., P (2004). Independent effects of endogenous and exogenous spatial cueing: inhibition of return at endogenously attended target locations. *Experimental Brain Research*, 159: 447–457.

Lupiáñez, J, Milán, E. G., Tornay, F. J., Madrid, E., & Tudela, P. (1997). Does IOR occur in discrimination tasks? Yes, it does, but later. *Perception and Psychophysics*, 59(8), 1241-1254.

Macaluso, E. (2010). Orienting of spatial attention and the interplay between the senses. *Cortex*, 46(3), 282-97.

Miles, E., Poliakoff, E., & Brown, R. J. (2008). Investigating the time course of tactile reflexive attention using a non-spatial discrimination task. *Acta psychologica*, 128(2), 210-5.

Mondor, T. A., & Amirault, K. J. (1998). Effect of same- and different-modality spatial cues on auditory and visual target identification. *Journal of Experimental Psychology: Human Perception and Performance*, 24(3), 745-755.

Müller, H. J., & Rabbitt, P. M. (1989). Reflexive and voluntary orienting of visual attention: time course of activation and resistance to interruption. *Journal of experimental psychology. Human perception and performance*, 15(2), 315-30.

Natale, E., Marzi, C. A., Girelli, M., Pavone, E. F., & Pollmann, S. (2006). ERP and fMRI correlates of endogenous and exogenous focusing of visual-spatial attention. *The European journal of neuroscience*, 23(9), 2511-21.

Poliakoff, E., Spence, C., McGlone, F. P., & Cody, F.W.J. (2002). Tactile inhibition of return: non-ocular response inhibition and mode of response. *Experimental Brain Research*, 146(1), 54–59.

Cite as: Jones, A. & Forster, B (in press). Independent effects of endogenous and exogenous attention in touch. *Somatosensory and Motor Research*, doi:10.3109/08990220.2013.779243

Posner, M. I. (1978). *Chronometric explorations of mind*. Hillsdale: Erlbaum.

Posner, M. I. (1980). Orienting of Attention. *Quarterly Journal of Experimental Psychology*, 32, 3-25.

Posner, M. I., & Cohen, Y. (1984). Components of visual orienting. In H. Bouma & D. G. Bouwhuis (Eds.), *Attention and performance X* (pp. 531-556). Hillsdale: Lawrence Erlbaum Assoc.

Posner, M. I., Rafal, R. D., Choate, L. S., & Vaughan, J. (1985). Inhibition of return: Neural basis and function. *Cognitive Neuropsychology*, 2(3), 211-228.

Rorden, C., Greene, K., Sasine, G., & Baylis, G. (2002). Enhanced tactile performance at the destination of an upcoming saccade. *Current Biology*, 12(16), 1429-1434.

Röder, B., Spence, C., & Rösler, F. (2000). Inhibition of return and oculomotor control in the blind. *Neuroreport*, 11(13), 3043-5.

Röder, B., Spence, C., & Rösler, F. (2002). Assessing the effect of posture change on tactile inhibition-of-return. *Experimental Brain Research*, 143(4), 453-62.

Santangelo, V., & Spence, C. (2007). Assessing the automaticity of the exogenous orienting of tactile attention. *Perception*, 36(10), 1497-1505.

Spence, C., & Gallace, A. (2007). Recent developments in the study of tactile attention. *Canadian Journal of Experimental Psychology*, 61(3), 196-207.

Spence, C., & McGlone, F. P. (2001). Reflexive spatial orienting of tactile attention. *Experimental brain research*, 141(3), 324-30.

Spence, C., Pavani, F., & Driver, J. (2000). Crossmodal links between vision and touch in covert endogenous spatial attention. *Journal of experimental psychology. Human perception and performance*, 26(4), 1298-319.

Theeuwes, J. (1991). Exogenous and endogenous control of attention: the effect of visual onsets and offsets. *Perception & psychophysics*, 49(1), 83-90.

Turatto, M., Benso, F., Galfano, G., & Umiltà, C. (2002). Nonspatial attentional shifts between audition and vision. *Journal of Experimental Psychology Human Perception and Performance*, 28(3), 628-639.

Yantis, S., & Jonides, J. (1990). Abrupt visual onsets and selective attention: voluntary versus automatic allocation. *Journal of experimental psychology. Human perception and performance*, 16(1), 121-34.

Cite as: Jones, A. & Forster, B (in press). Independent effects of endogenous and exogenous attention in touch. *Somatosensory and Motor Research*, doi:10.3109/08990220.2013.779243