

Chen, B., Riley, P. H., Abakr, Y. A., Pullen, K. R., Hann, D. B. & Johnson, C. (2013). Design and development of a low-cost, electricity-generating cooking Score-Stove™. Proceedings of the Institution of Mechanical Engineers, Part A: Journal of Power and Energy, 227(7), pp. 803-813. doi: 10.1177/0957650913498733



**CITY UNIVERSITY  
LONDON**

[City Research Online](#)

**Original citation:** Chen, B., Riley, P. H., Abakr, Y. A., Pullen, K. R., Hann, D. B. & Johnson, C. (2013). Design and development of a low-cost, electricity-generating cooking Score-Stove™. Proceedings of the Institution of Mechanical Engineers, Part A: Journal of Power and Energy, 227(7), pp. 803-813. doi: 10.1177/0957650913498733

**Permanent City Research Online URL:** <http://openaccess.city.ac.uk/8424/>

### Copyright & reuse

City University London has developed City Research Online so that its users may access the research outputs of City University London's staff. Copyright © and Moral Rights for this paper are retained by the individual author(s) and/ or other copyright holders. All material in City Research Online is checked for eligibility for copyright before being made available in the live archive. URLs from City Research Online may be freely distributed and linked to from other web pages.

### Versions of research

The version in City Research Online may differ from the final published version. Users are advised to check the Permanent City Research Online URL above for the status of the paper.

### Enquiries

If you have any enquiries about any aspect of City Research Online, or if you wish to make contact with the author(s) of this paper, please email the team at [publications@city.ac.uk](mailto:publications@city.ac.uk).

# Design and Development of a Low-Cost, Electricity-Generating Cooking Score-Stove™

B.M.Chen<sup>a\*</sup>, P.H.Riley<sup>b</sup>, Y.A.Abakr<sup>a</sup>, K.Pullen<sup>c</sup>, D.B.Hann<sup>d</sup>, C.M.Johnson<sup>b</sup>

<sup>a</sup>Energy, Fuel and Power Technology Division, the University of Nottingham Malaysia Campus, Malaysia

<sup>b</sup>Faculty of Electrical Engineering, the University of Nottingham, Nottingham, NG7 2RD UK;

<sup>c</sup>Faculty of Mechanical Engineering, City University London, London EC1V 0HB UK;

<sup>d</sup>Faculty of Mechanical Engineering, the University of Nottingham, Nottingham, NG7 2RD UK

\*Corresponding author. Email:

## Abstract

SCORE ([www.score.uk.com](http://www.score.uk.com)) a US\$4M, 5 year international collaboration research project aims to improve the life quality of the 1.5 billion people worldwide who cook on an open fire and do not have access to electricity. SCORE market evaluations<sup>1</sup> indicate that at the upper-cost target of \$120 with 20 Watts of electricity 60 million people would afford the stove. At the lower-cost target of \$40 and 100 Watts it would be affordable to over 1 billion people. In November 2010, a wood burning Score-Stove™ prototype successfully developed 23 watts of electricity based on a planar Thermo-Acoustic Engine (TAE) [2],[3],[4],[5],[6] design, indicating that the new Score-Stove™ is now ready to be engaged with manufacturers to gear up for volume production, and therefore to meet the social and cooking requirements of the rural poor people. The development to a large-volume, easy to manufacture, low-cost TAE cooking stove using elements of the formal design methodologies of BS 7000 and TRIZ are discussed. By breaking down the system requirements into cost targets for each module, performing rig testing, and design refinements it is believed that the upper-cost target is achievable with the right level of investment.

**Keywords:** BS 7000, Electricity, Score-Stove™, Thermo-Acoustic Engine, TRIZ

## 1.0 Introduction

There are about 1.5 billion people worldwide [7] who use biomass as their primary form of energy in household cooking. They do not have access to electricity, and are too remote to benefit from grid electrical supply. In many rural communities, the stoves are the traditional 3 stone type made without technical advancements. These open fires cooking stoves have extremely low efficiency; about 93% of the energy generated is lost during cooking. Often, the cooking is done inside a dwelling and creates significant health hazard to the family members due to smoke inhalation and pollution to environment. SCORE is an international collaboration research project to design and build a low-cost, high efficiency woodstove that uses about half amount of the wood of an open wood fire, creates little smoke and uses the waste heat of the stove to power a thermo-acoustic generator to produce electricity for such uses as LED lighting, charging mobile phones or to charge a 12V battery. In an early part of this work, a propane driven prototype Score-Stove™ was successfully constructed and demonstrated to produce a maximum of 15 Watts of electricity ( $W_e$ ) indicating that Thermo-Acoustic Engine (TAE) technology has the potential to provide a cooking stove that also generates electricity for use in developing countries at an affordable price. During the last few years, Score has worked with Aster Thermoakoestische Systemen in the Netherlands [8] to develop a wood burning twin regenerator Score-Stove™ based on the planar TAE design. A simplified rig was built and tested that produced 22.7 Watts of electricity in November 2010.

The final TAE design Score-Stove™ evolved through five stages of development with considerable technical challenges both in the thermo-acoustic and manufacturing methods. An adaptation of an aerospace best practice process based on the formal design process of BS 7000 and elements of the TRIZ methodology was employed. The main design strategy has been geared towards ensuring the fulfilment of the required functionality of each module and cost target. Therefore, the selection of manufacturing techniques and use of standard parts or modular construction was consideration during the design phases. Finally the unit modelled in Pro-Engineer and its detail drawing of each module is prepared for manufacturing.

## 2.0 Functional Requirements

The Score functional requirements are based on end user surveys to distil the common stove requirements to meet a wide range of rural community needs. However, many variations of the Score-Stove™ may be needed to meet the different local requirements and attract more people of rural communities to the benefits of Score. A web-based knowledge community of practice has been created to store the variations and for idea sharing.

The design intent is to develop a unit that will operate at least five years without requiring repair of the stove body and without any significant drop in performances or increased emissions. Other Product Design Specifications (PDS) such as size, weight, product cost and reliability are outlined below. Based on the survey results where available otherwise engineering judgement was used, as shown on table 1 and 2.

Table 1: General design specification

Overall size of the whole system	600 mm x 600 mm x 700 mm
Overall weight of the whole system	Less than 20 kg
Cost of per unit	Less than \$40
Lifespan of the main components	Greater than 5 years
Maintenance	No maintenance other than general cleaning needed

Table 2: General system specification

Type	Travelling wave
Feedback loop	One fourth and three fourth wavelength
Electricity power generation	150 W <sub>e</sub>
Operating frequency	100 Hz
Working regenerator temperature	400°C
Cold heat exchanger	Up to 100°C
Working fluid	Air
Pressure	Unpressurised if possible. Otherwise < 200kPag.
Power supply from wood	4.4 kW <sub>th</sub>
Linear alternator type	Double Halbach array

### 3.0 Design and Development

The current design effort is targeted at optimizing the functionality of the system to approach the requirements of large volume production. Although simple in concept (a wood or dung burning stove that also produces electricity) the Score-Stove™ design is complex because of the severe cost constraint imposed on the application. Therefore an adaptation of an aerospace best practice design process based on BS 7000 design process and a powerful technical problem solving methodology, TRIZ was employed.

The BS 7000 series of standards relate to design management and provide a comprehensive framework and guideline to construct the design process. Early in the process, user requirements are captured, followed by functional requirements, module definition and eventually manufacturing definition. Guidance also covers iterations between each design stage. Whilst the early stages of the design might incur only modest non-recurring (design) cost, it is here that key decisions are made and up to 80% of the manufacturing costs committed. During the design stages, a balance needs to be achieved between the materials selection, and manufacturing technologies utilised.

TRIZ is a methodology invented in Russia by evaluating many thousands of published Patents and extracting a method of invention from them. By describing parts by their function and in an abstracted way, they produced a library of ways to solve new problems based on previous innovations. Additionally each part is analysed to maximise the number of functions it performs and remove parts that do not contribute to functionally. Some say the method is irreplaceable for solutions to extremely difficult problems.

Using these design processes, Score has simplified the design whilst reducing the number of

components and maintaining the functional requirements listed in the various design documents. These requirements were then formulated in the form of contradictions, such as the functional requirements and the cost targets. Aspects of the TRIZ method helped to improve system performance and increase the ideality of each design stage by lowering costs and reducing weight.

The design method used in Score is presented on Fig 1. It is highly iterative and aims to provide better optimisation of the design early in the process, so as to reduce the cost both by better optimisation of the system and reducing the number of proof of concept prototype units that need to be manufactured. The main design strategy has been geared towards ensuring the fulfilment of the cost target (as cost is the main driver in the Score application). The selection of manufacturing techniques and use of standard parts or modular construction were also taken into consideration during the design phases.

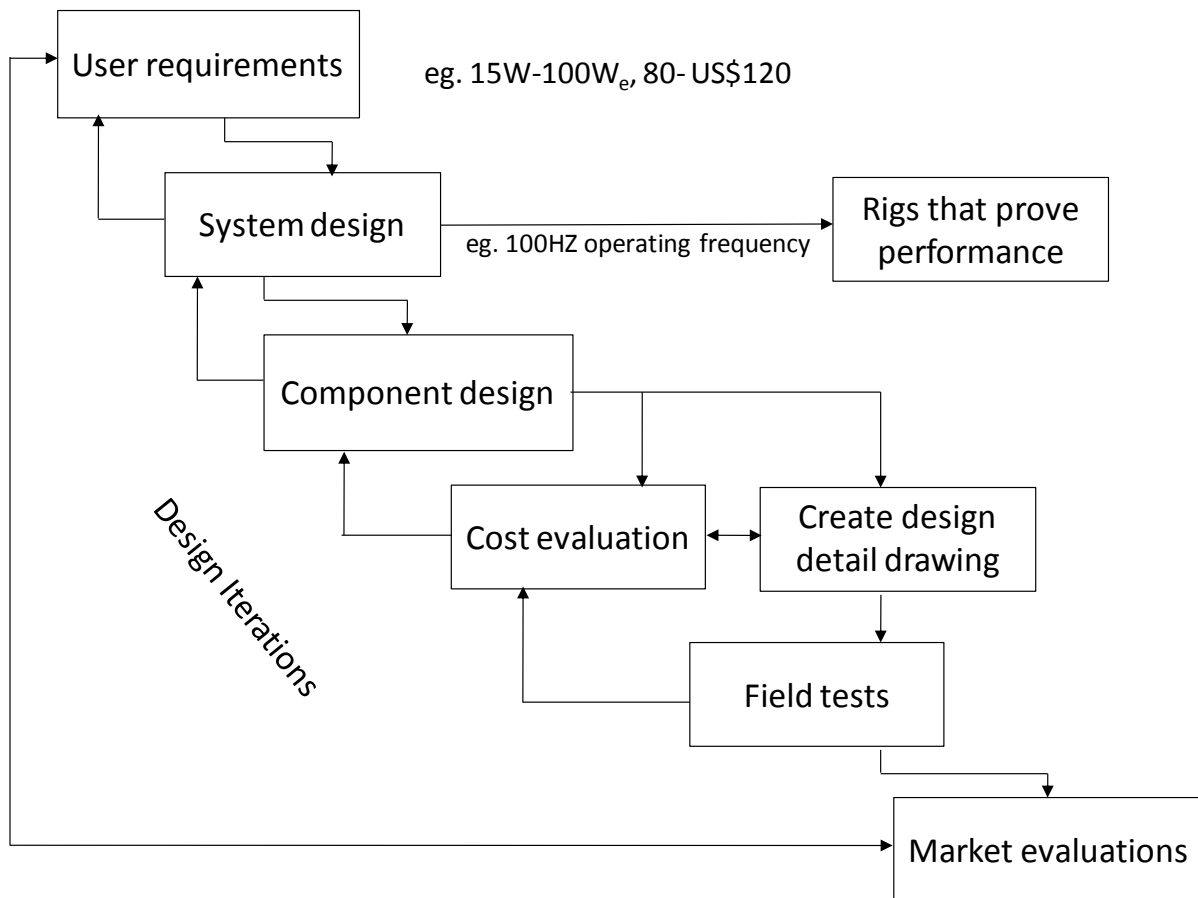

**Fig 1 Iterative design method used by the Score project**

The functional diagram of a single regenerator TAE is shown on Fig 2(a). Heat is supplied from the burning fuel to the working TAE gas (air in the Score case) via a Hot Heat Exchanger (HHX), heat is extracted via the Ambient Heat Exchanger (AHX) and secondary heat exchanger. The wave travels through the Thermal Buffer Tube (TBT) where it is cooled and around the feedback pipe to the linear alternator where the acoustic power is absorbed and converted to electrical energy. The tuning stub is to improve the impedance matching between that linear alternator and the engine. Due to the low calorific value of wood, and hence a lower combustion flame temperature the Score-Stove™ Demo 2 uses a dual regenerator design (Fig 2(b)) which has the effect of reducing the onset-temperature ( $T_{hot}-T_{cold}$ )<sup>9</sup>.

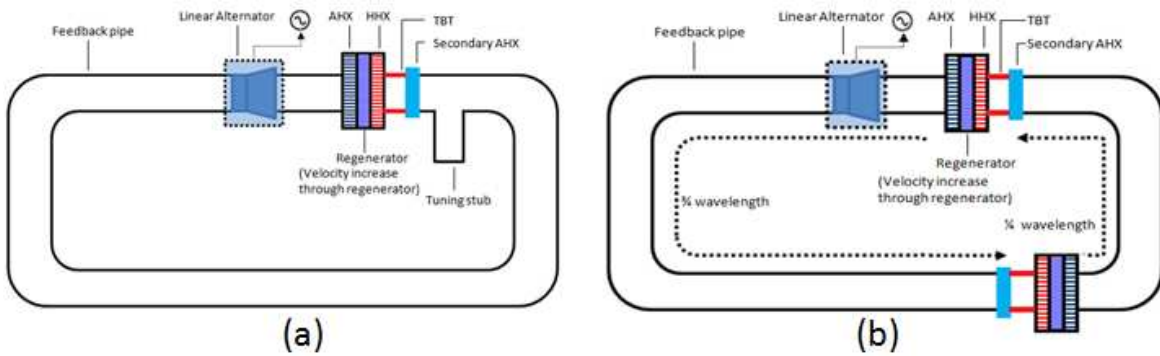

**Fig 2 Functional diagram of the TAE**  
**(a) Left, a single regenerator TAE;**

**(b) Right, a dual regenerators TAE**

The general physical outline of the wood burning Score-Stove™ design is illustrated on Fig 3. It consists of six main modules: stove carcass (including combustion chamber and insulation), stove hob, TAE system, feedback piping, linear alternator and water reservoir (not shown in the figure). The TAE system combines two identical engine stages positioned close to each other in what we call a dual regenerator configuration. The TAE system is the core module that determines overall performance and is the most costly part of the entire system. The final design of the TAE has been evolved to fulfil the project targets through five stages. The evolution of a single TAE is described in Table 3 and the cross section view of a single TAE design, is illustrated as Fig 4. This paper only covers the planar TAE design. Linear Alternator optimisation is published elsewhere [10], [11].

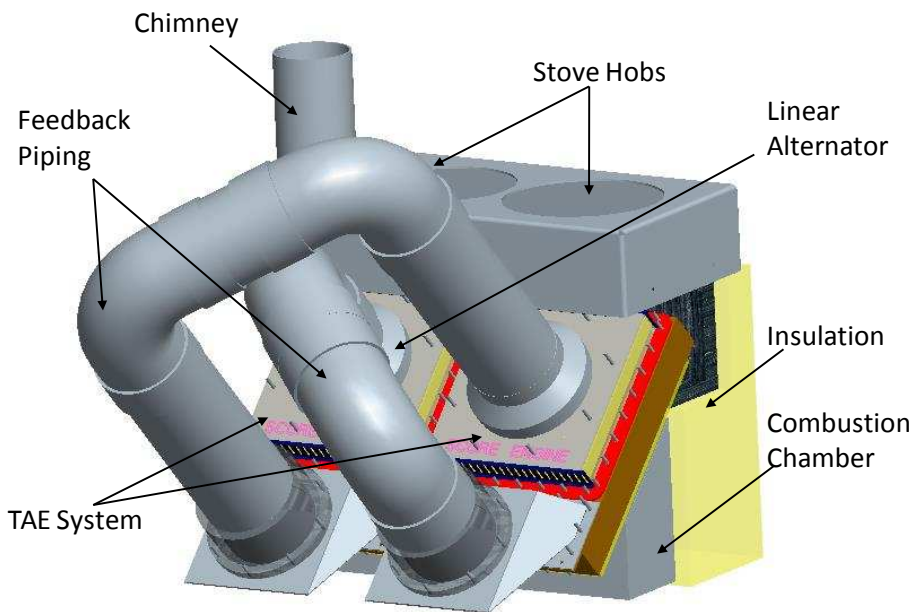

**Fig 3 General arrangement of the Score-Stove™**

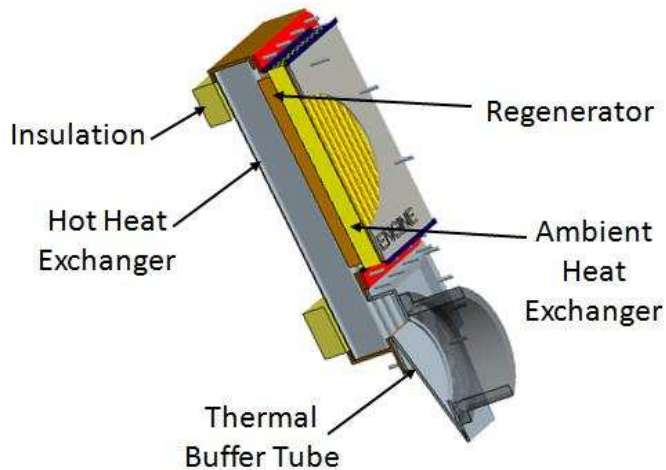

**Fig 4 The cross section view of a single TAE design**

### 3.1 Working principle

Heat is supplied to the system by burning of fuel (not shown on figure) inside the combustion chamber, heat then transfers to the HHX from the fire by a combination of convection and radiation. The lengths of each loop of the feedback pipe are configured to be 1 meter and 3 meters so as to form a  $\frac{1}{4}$  wave and  $\frac{3}{4}$  wave. Quarter wave devices are able to reduce reflections (in the same way that  $\frac{1}{4}$  wave coatings are put in spectacles to reduce unwanted reflections at optical frequencies) and  $\frac{3}{4}$  waves have the same property. By using these lengths of pipe, the effects of impedance mismatches are reduced that produces a near travelling wave around the loop, hence reducing losses. To achieve adequate electrical output, early tests have shown that a higher acoustic intensity is required and so the working pressure is now 100k - 200kPag. Rejected hot gas of TAE flows up through the heat-guide to the stove hob for cooking by conduction and convection. Rejected heat of TAE is also absorbed by the AHXs and can be used for cooking and/or water purification for drinking. Finally, system emission is taken through the chimney.

### 3.2 Design process

Demo0#3 [12] (Fig 6a) was an early propane driven Score TAE that produced 15  $W_e$  power using a compact HHX that transferred heat mainly by radiation. Fig 6b shows the Demo1 [13] configuration. Demo 2 contains the best elements of each design. Experiments have shown that thermal losses are higher than expected due to parasitic heat flows, which resulted in lower electrical output. Initially, a radiant HHX design was utilised to reduce cost, however, we have not been able to obtain as high a flame temperature with wood combustion compared with propane. This had a large effect on heat transfer due to the  $T^4$  term and so a new convoluted plate design was used with increased area (but at a slightly higher cost) that is more tolerant of lower temperatures because heat is now transferred mainly by conduction. Assuming the same projection of the heating input area as shown on Fig 5, the surface area of a convolution design is about 3.5 times bigger than the radiant design and is used in the new design in order to enable more heat to be transferred via conduction. This convolution design is therefore applied from stage 1 onwards, the main function being a wood burning TAE which can be integrated with the stove.

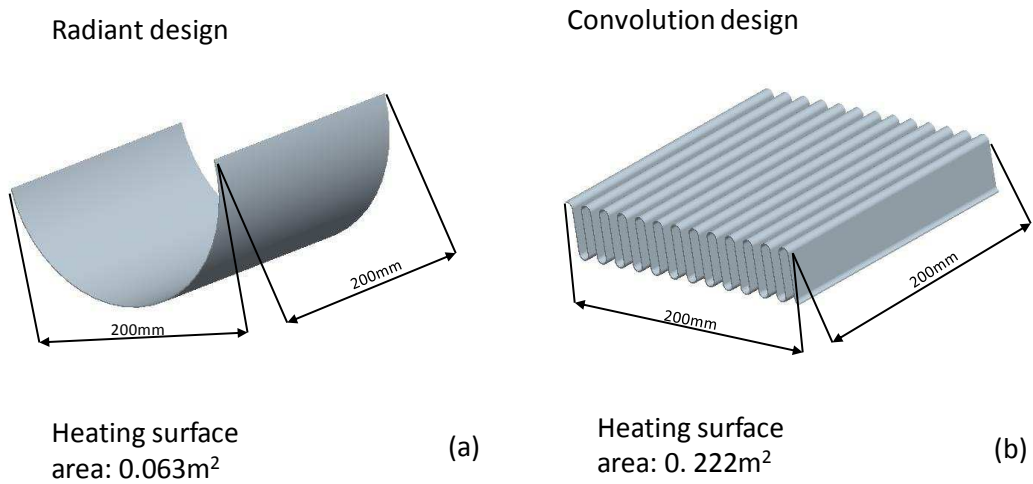

**Fig 5 Radiant design and convoluted design for HHX with same projection area of 200 mm by 200 mm. (a) Radiant design heating surface area is 0.063 m<sup>2</sup>; (b) Convoluted design heating surface area is 0.222 m<sup>2</sup>**

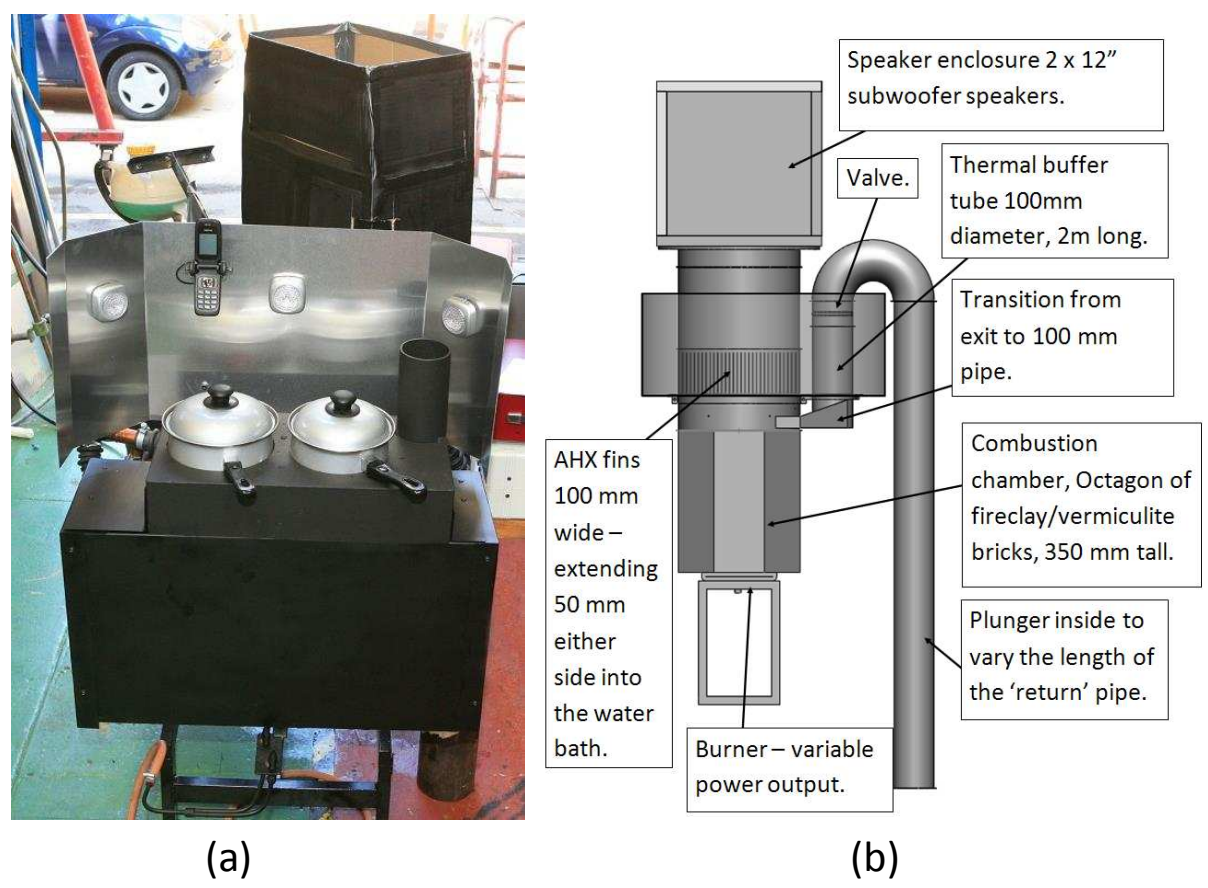





**Fig 6 (a) The early propane driven Score-Stove™ (Demo0#3); (b) Queen Mary University Design (Demo1)**



Table 3 documents the design changes made from Demo0#3 and Demo1 to the new design (Demo2). Demo2 has the TBT outlet at the bottom to prevent the parasitic convection in the feedback tubes observed in both demos.

**Table 3: The 5 stages evolution of the Thermo-Acoustic engine**

	<p><b>Stage 1.</b> A dog leg shape design with corrugated HHX and 45 degree-folded TBT replaces the radiant HHX of Demo0#3. The convoluted HHX design increases the heating surface area therefore being more tolerant of lower combustion temperatures due to wood burning. An adaptation of a radiator is used as an engine AHX to minimize fabrication cost.</p>
<p>The 45 degree angle was chosen so that AHX radiator cooling can be via thermo-siphon (no pump required) whilst maintaining a good path for combustion gasses along the HHX convolution.</p>	
	<p><b>Stage 2.</b> A planar design with combination of corrugated HHX and TBT in a single unit. This specialist convoluted HHX is then welded to the engine frontal flange without the need of frame. The size of the TAE is significantly reduced by removing the dog leg shape and frame hence the cost is cut down due to easy manufacturing/assembly as well as using standard plastic parts for the stub-flange.</p>
	<p><b>Stage 3.</b> The specialist convoluted HHX was outside the existing manufacturing process capability due to the long depth of the convolution, so this version separates it into two pieces. The corrugated HHX can be made either using a bending machine or hydraulic presses with appropriate tooling, and then welded to the HHX flange. However, the welding process is expensive.</p>
	<p><b>Stage 4.</b> Analysis of stage 3 showed that there was inadequate volume through the bottom of the engines so the bottom end of the corrugated HHX needs to be chamfered to allow the air to flow without blocking it. This causes a problem of difficult sealing and extra machining. A solution to this is to plump up a drum on the engine frontal flange to allow adequate flow of air.</p>

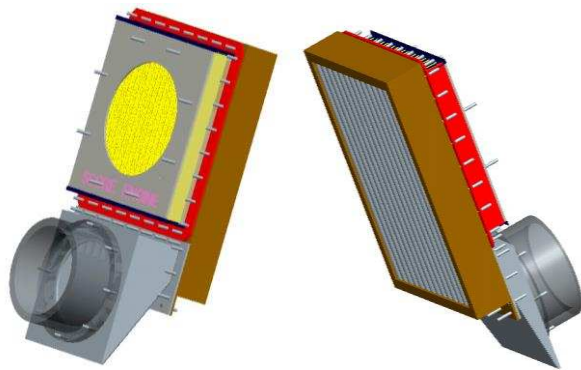

**Stage 5.** The previous design requires full welding on all flanges therefore manufacturing cost is too high. A soft solder or even a polymer joint between the convolution and frame eliminates the need of welding. The TBT is formed from 5 pieces of mild steel welded together. The frame is made from low cost standard segmented rectangular-hollow-section mild steel bar. The corrugated HHX here is increased in size slightly and its thin section and relatively low thermal conductivity means that parasitic heat transfer is reduced, and the frame kept at a low temperature using appropriately placed insulation both inside and outside the frame.

The initial concept was a dog leg shape with a corrugated HHX and a 45 degree-folded TBT. (This is based on the orientation of the engine when it is integrated with the stove hob). Stage 2, is an improved version that reduces engine weight and hence cost. The 45 degree-folded TBT design is replaced by a more planar design combined with the HHX in one unit. The engine frame is eliminated by welding the HHX unit to the engine frontal flange. A standard part (the stub-flange) is used to minimize unnecessary fabrication cost. These changes result in a significant weight reduction and therefore less cost for materials. This planar concept design was validated by building a prototype and will be discussed shortly. A problem was encountered when this design was in the first phase of manufacturing. The specialist convolution is not thought manufacturable with available manufacturing process capability. In stage 3, this specialist convolution is simplified into a corrugated HHX and a separate HHX flange. The corrugated HHX could be made either using a bending press then welded it to the HHX flange or by means of a stamping process. In this design, the bottom end of the corrugated HHX needs to be chamfered to allow the air to flow without blocking by the lower HHX region. Unfortunately, the chamfered angle on the corrugated HHX not only requires an extra manufacturing process also very difficult to be sealed. In stage 4, the chamfered section on the corrugated HHX is removed due to the critical sealing problem. The TBT is redesigned to plump up a drum on the engine frontal plate to allow air to flow. In order to maximise the functionality of the design, the shape of the drum is made to allow the second heat exchanger (aluminium foam) to be easily fixed. This design ultimately was not adopted because manufacturer quote showed the welding cost too high; it may be of use at a later date if a fully welded unit is required, for example to contain helium as the working gas. In stage 5, the main design effort is targeted to minimize unnecessary welding. An engine frame is introduced to obviate the need for welding. This frame may be made out of standard square or rectangular section and split or bent from flat plate. The engine frame is changed to a low temperature design, and uses a combination of the low thermal conductivity of stainless steel in the corrugations and insulation to enable low temperature sealing of corrugated HHX. Sealing can be done with soft solder in a method called flooding. This also allows the system to be pressurized hence improve the engine performance. In this design, the TBT is made out of 6 pieces of mild steel plate, requiring a small amount of welding to be done.

Through these five stages of evolution, the soft solder/polymer planer design (stage 5) has obvious advantages on low cost manufacturing techniques and assembly compared to the early Demo0#3 design and other previous stages. The use of standard parts (stub-flange, square-hollow-section bar) and low cost manufacturing techniques (solder/polymer instead of welding) are key tactics to achieve the cost targets. The cost analysis of each stage based on material cost in mass production is described later. The next section shows the verification of the innovative prototype.

#### 4.0 Verification

In November 2010, a planer design of TAE system prototype was made by Aster Thermoakoestische Systemen and has been demonstrated at City University London by integrating with the wood burning stove, developed by City University London to understand the interaction between the TAE and wood combustion. Fig 7 shows that the TAE prototype consists of two identical TAE engine stages close to each other and was positioned on low-cost fire-brick housing at an angle of about 45° which allows the burning gases of the wood to flow along and between the fins. This TAE system was based on the concept of a planer design with smaller diameter 75 mm PVC pipe in the feedback loop and using back to back aluminium heat sinks (as an easier way to prove the planar concept before full convolution tooling was made) as the hot heat exchanger. Use of a larger diameter pipe will give higher acoustic intensity but take up extra space, so pressurisation was also investigated. A B&C™ 172 mm diameter loud speaker was used as a linear alternator and it is coupled to one of the AHX of TAE to extract the electricity from acoustic power.



**Fig 7 (left) The planar design TAE system integrated with the Wood Burning Stove**

**Table 4 Measured electrical load power from the wood burning Score-Stove™**

Pressure (kPag)	Load ( $\Omega$ )	Load power (W)
50	12	23
Ambient	24	12.6

#### 4.1 Result and discussion

In this experiment, a total of 1.5 kg wood of about 20% moisture content was burnt over about 55 minutes, which is equivalent to 7 kW thermal heat input. The wood burning stove produced an average flame temperature of around 750°C and a maximum of about 1000°C. The acoustic oscillation at a frequency of about 80 Hz was produced at 15 minutes after ignition. Table 4 shows that the maximum measured electrical power was obtained to be around 23 W<sub>e</sub> on 12  $\Omega$  load resistances when the TAE was pressurized to 50kPa gauge. A power of 12.6 W<sub>e</sub> on 24  $\Omega$  load resistance was generated when the TAE was running at atmospheric pressure.

## 4.2 Limitations:

- (1) The corrugated back plate is simulated by two aluminium finned heat sinks mounted back to back acting as the HHX transferring heat from the stove to the regenerator. This however unnecessarily increases the weight of the engine and introduces an unwanted additional 30-50 K temperature drop between outer fins and regenerator.
- (2) Due to mechanical stress and distortion of the flat back plate construction mean pressure is limited to 50kPag.
- (3) Due to the sealing material limitation, required for the two profiles, regenerator temperature is limited to about 300°C.
- (4) A B&C™ 6PS38 speaker was used having a measured acoustic to electric efficiency of 35%. (We expect the new alternator to have efficiency nearer to 60%)

The combined assessment of the results and the limitations of the prototype, indicates that the planer TAE design concept is overall applicable, although the results are below the project target of 100 W<sub>e</sub>. Simulations show that performance could be improved if the TAE is pressurized to 200kPa absolute. According to the theory and experience, thermo-acoustic engine performance rapidly improves at increasing mean pressure. This has been well proven from the testing while a significant power increment of 45% was achieved when the TAE was pressurized to 50kPag. Further heat loss of the HHX should be minimized using the corrugated HHX design. An efficient, low-cost linear alternator is being tested to give better electricity output. In conclusion, assuming a reduction of heat loss and a slight improvement of the alternator performance the project target of 100 W<sub>e</sub> seems very well feasible within the size of the prototype.

## 5.0 Cost Analysis

By integrating the requirements and market penetration evaluation, Score stated that the research is setting a target price of \$40 with about 50% of market penetration, for a 100 Watts electricity-generating cooking stove as delivered to the capital city of the country to allow for local profit, transport and development cost overruns. In the community of Nepal, the average household income is about \$1500 per year. So setting a maximum price for one unit at \$40 delivered to the main city or \$60 delivered to the village is considered reasonable. A porter in Nepal can carry up to 30 kg, so low transported weight is important. Cost to hand carry goods to the remote regions, where there are no roads is about \$0.8 to \$1 per kg, so transportation costs charge for a 30 kg load is \$30. The transportation cost of a heavy unit will effectively double the price, restricting the construction budget substantially and possibly impact on the quality of the product. A maximum transported weight limit of 15 kg per unit should ensure delivery to major cities, where the device can then be sold with or without delivery to the consumers dwelling.

Fulfilment of the desired targets requires very large manufacturing volumes in excess of one million units per annum. We expect the high technology parts to be produced in a low cost manufacturing centre and imported to the desired country where local skills in towns can be used to weld the units together. Installation will be in the rural community country itself using local materials to reduce the transported weight. The cost analysis of each stage is based on material costs from the London Metals Market at the end of 2007. It should be noted that these costs being the lowest possible achievable, even in low labour markets. Since the targets were set, some commodity prices have increased significantly (as have disposable incomes) and exchange rates have changed. We use the rates at 2007 to maintain an accurate comparison between the various designs. When the project enters production, the costs will

be re-based to current values. During the later marketing activity required for mass production, the costs will be re-based at that time and we predict that rural living standards will also improve, so the additional costs will not affect affordability. Table 5 shows the basic summary of each design stage. The early propane driven Score-Stove™ is used as the baseline design through the design process.

**Table 5 Basic summary of the design stages**

Design stage	Change	Reason of change	Total mass estimate (kg)	Transported mass estimate (kg)	Material cost estimate (\$)	Indirect cost estimate (\$)	See notes	Total cost estimate (\$)	Power estimate (W)
0	Baseline design (Demo0#3)	N/A	61.72	41.72	166.40	400.00	1	566.40	15
1	Increased HHX area	Increased heat flow needed	58.24	39.04	164.15	114.00	2	278.15	23
2	Planar design, combine HHX and TBT in one unit	To reduce mass and assembly cost	50.81	31.61	150.18	N/A	3, 4, 5	N/A	30
3	Striped down HHX and TBT	Ease of manufacture	51.32	32.12	152.05	114.00	3, 4	266.05	30
4	Plump up TBT on top flange	Improve sealing and reduce HHX cost	52.05	32.85	153.10	94.00	3, 4	247.10	30
5	Surround changed to low temp and using insulation to enable low temperature sealing of convolutions	Reduce welding cost. (Manufacture quote obtained for stage4 showed welding cost too high)	53.40	34.20	154.81	54.00	2, 4	208.81	50
<b>Predicted</b>	Lightweight design use of concrete and low cost regenerator mesh	Predictions to get closer to target. Research needed to obtain result	33.12	13.92	33.74	34.00	2, 4	67.74	100

**Notes:**

- 1 Assumes low volume build methods with low cost labour, and high volume material costs.
- 2 Assumes high volume (> 100k pa) manufacture with tooling paid for elsewhere. i.e. no amortisation
- 3 As note 2 but with extra cost due to estimated increase in manufacturing costs due to long welding runs.
- 4 Power estimation is based on engineering judgements.
- 5 No cost available as one piece convolution not manufacturable.
- 6 Indirect cost including manufacturing, profit, assembly and delivery cost. Excluding installation.
- 7 Mass is the total weight of the Score-Stove except insulation material and water reservoir.
- 8 Exchange rates are based on 2007 rates.
- 9 Materials costs are calculated for each module based on the London Metals market at the end of 2007.

Each computed Score cost prediction is presented in the table above. Through the stages above, the baseline design has the highest total cost and weight and lowest power produced. In stage 1, the new design concept (corrugated HHX) not only enhances the engine performance in higher electricity power generation but also reduces the weight and total cost compared to the baseline design. Originally stage 2 was intended to reduce engine weight and its cost on this design iteration. It should be the cheapest among the 5 stages in total cost and low weight if a manufacturing process were available. However, it appears to be outside current manufacturing process capability. In stage 3, both the material cost and weight are slightly higher than stage 2 due to the longer HHX design. However, this result was

satisfactory if compared to stage 1 in both material cost and weight, especially weight reduction of about 7 kg in this stage. In stage 4, although material cost increases about \$1 due to the use of more material of 0.73 kg but reduces almost 7.7% of its total cost by eliminating unnecessary machining. However, the welding cost at the end of the convolutions is very high. In stage 5, we have traded off reduced welding costs (the unit can be bonded using polymer or soft soldered in one process) for weight which increased by 1.35kg due to the mild steel surround and longer HHX requirement. This stage significantly reduces manufacturing cost due to absence of the costly welding works. These result in about 18.3% total cost reduction compared to the previous stage or about 170% total cost reduction compared to the baseline design. Overall, the stage 5 design has achieved a good cost reduction with reasonable weight and also be the highest power production thought all those five stages. These are significant improvements, although still above the target and are the best that can be achieved with current understanding. The next section outlines future work needed to meet the target cost.

### **5.1 Plan for future cost reduction**

To fulfill the Score cost target price, the following would be required:

- Change the mesh material from stainless steel to a lower cost material; we are looking at fibre glass or rock wool. Unfortunately we have been unable to find any that meets the requirement off the shelf.
- Form the feedback pipes by casting them in (low cost) concrete (preferably aerated) with a thin liner. This would replace the thick plastic pipes of stage 5.
- Remove the bolted joints and one flange face, and bond in one process step.
- Use a material similar to aerated concrete that can withstand  $>1000^{\circ}\text{C}$  temperature to form the main carcass and hob unit in one casting.
- Reduce material thicknesses by better stressing of complex shapes.
- Reduce labour by diffusion bonding thin sections in one operation. (Score has a patent to cover this)
- Reduce radiator cost by using aluminium rather than brass. To do this we need to solve a galvanic corrosion issue. At the moment any thin section Al corrodes quickly if we use plain water as the coolant.
- Better match the linear alternator to the TAE and have a more optimized TAE feedback pipe topology to increase power.
- Reduce the thickness of the Stainless steel convolution, or use cheaper material suitably coated. The main issue here is thought to be corrosion. At  $600-700^{\circ}\text{C}$  particularly acacia wood has a high salt content and produces HCl that can corrode even Stainless Steel.

### **6.0 Conclusion**

The unit was modelled in Pro-Engineer and a detail drawing of each module created to form the basis of assessing the design options. During the design stages, an adaptation of an aerospace best practice process based on the formal design process of BS 7000 and a powerful technical problem solving methodology, TRIZ, was used. These tools enabled a highly iterative process that maximised the functionality of each component whilst minimising cost.

The latest TAE design has developed the wood burning Score-Stove™ through five design stages. By breaking down the system requirements into functional requirements then

undertaking a cost analysis for each module and performing rig testing and design refinements, the following improvements are predicted compared with the baseline design:

- Transported weight reduction of about 66%
- material cost reduction of about 86% and total cost reduction of 171%
- estimated power increment of 70%

The cost reduction methods have been provided to get to the predicted figure and to fulfil the Score cost target price.

Based on all these, the final TAE design has a big potential to engage with manufacturers to gear up for mass production, and therefore to meet the social and cooking requirements of the rural poor people.

## Acknowledgments

The support of EPSRC for this work under the SCORE project is gratefully acknowledged, as are the contributions of the other partners.

## References

- 1 Riley, P.H., Saha, C., and Johnson, C.J., “Designing a Low-Cost, Electricity Generating Cooking Stove”, *Technology and Society Magazine IEEE*, summer 2010. Digital Object Identifier 10.1109/MTS.2010.937029, 1932-4529/10/\$26.00©2010IEEE.
- 2 G. Swift, Thermoacoustic engines, *J.Acoust. Soc. Am.* 84(4),1145-1180, 1988.
- 3 Catherine Gardner and Chris Lawn “Design Of A Standing-Wave Thermo-acoustic Engine”, The sixteenth International Congress on Sound and Vibration, Krakow 5-9 July 2009
- 4 Riley PH, Saha C, Johnson CJ, “Application of Thermo-Acoustic, electrical generating engines in rural areas”, IIT Delhi 7-9 September 2010
- 5 Zhibin Yu, Scott Backhaus, Artur J Jaworski “Design and Testing of a Travelling-wave Looped-tube Engine for low-cost electricity generators in remote and rural areas” 7th International Energy Conversion Engineering Conference 2 - 5 August 2009, Denver, Colorado
- 6 Yu Z, Jaworski A J. 2010. "Impact of acoustic impedance and channel dimensions on the power output capacity of the regenerators in travelling-wave thermoacoustic engines". *Energy Conversion and Management*. Vol. 51. Issue 2. pp 350-359.
- 7 The World Bank 2005 Rural energy and development for two billion people: Meeting the challenge for rural energy and development (September) [[http://siteresources.worldbank.org/INTENERGY/Resources/Rural\\_Energy\\_Development\\_Paper\\_Improving\\_Energy\\_Supplies.pdf](http://siteresources.worldbank.org/INTENERGY/Resources/Rural_Energy_Development_Paper_Improving_Energy_Supplies.pdf)]
- 8 <http://www.aster-thermoacoustics.com/>
- 9 B. M. Chen, P. H.Riley, et al., “Design and Testing of a Wood Burning Electricity Generator by using Dual-Core Thermoacoustic Engine”. 2011 World Congress on Engineering and Technology (CET), Shanghai, China, 2011. “accepted paper and Unpublished”
- 10 Saha C.R., Riley P.H., Johnson C.J., Paul J., Yu Z., Jaworski A. “Halbach array linear alternator for thermo-acoustic engine” *Energy conversion and management Journal*, (submitted paper).
- 11 P. H. Riley. and C. M. Johnson, Generating electricity in developing countries using thermo-acoustics powered by burning wood, *Acoustics 08*, Paris, June 2008.
- 12 B. M. Chen, P. H. Riley, and Y. A. Abakr, Construction and Assessment of a Propane driven, Electricity-Generating Cooking Score-Stove™ in International congress on Green process Engineering 2011: Kuala Lumpur Malaysia. “accepted paper and Unpublished”
- 13 Catherine Gardner and Chris Lawn “Design Of A Standing-Wave Thermo-acoustic Engine”, The sixteenth International Congress on Sound and Vibration, Krakow 5-9 July 2009. Link