



Waste Tire Application in Concrete Structures

Agus Maryoto^{1*}, Sugeng Waluyo¹, Yanuar Haryanto¹, Nor Intang S.H¹, Nur Alvi Anisa¹

¹Department of Civil Engineering, Faculty of Engineering, Jenderal Soedirman University
Jl. Mayjen. Sungkono Km. 4, Purbalingga, Jawa Tengah, Indonesia, 53371.

*Corresponding author, email: agus_maryoto1971@yahoo.co.id

Received : October 18, 2016

Accepted : April 17, 2017

Online : April 25, 2017

Abstract – The waste tire is produced more than 10 million tons every year in the world. This problem needs serious treatment to eliminate the waste tires. This work is aimed to recycle the waste tire in concrete as a reinforcement. The contribution of the waste tires in flexural strength capacity of concrete is investigated by using experimental work and numerical simulation. Since material is quite non-homogenous compared to the pure concrete, we use six concrete beam specimens with dimension 150 mm x 150 mm x 1000 mm to get better fitting results. One specimen is non reinforced concrete beam and five specimens are waste tires reinforced concrete beam. For each of the five specimen, the waste tire reinforcement is tensioned with 0%, 17%, 25%, 40% and 60% strain before casting the concrete. The flexural strength tests are conducted after 28 days concrete ages under three point loadings. After the test, we observe that the waste tire reinforcement together with pre-stress contribute significantly on the flexural strength of the concrete beam as predicted. Especially, maximum load on the specimen WTR-40 increases 28.8% compared to the specimen NR. Finally, to support the test, finite element analysis is performed as well in this work and compared with the experimental results. We found that numerical simulation has a little difference to the experimental result.

Keyword: Waste tire; recycle; reinforced concrete; flexural strength.

Introduction

Production of waste tires in the world has increased significantly in the 20 years recently. Taiwan generated approximately 1 million tons of waste tires each year (Yang, *et al.*, 2002). Japan, The USA and Uni-Europe produced about 1 million, 3 million and 4 million tons of waste tires every year respectively (Edeskar, 2006). Indonesia as developed country also contributes on the growing of waste tires in the world. Its contribution is about 20 million pieces of waste tires per year (Maryoto, et al., 2015).

The waste tires is not able to be demolished by environment, both biological and chemical processes (malek and Stevenson, 1986), and chemical or acid attack (Reddy and Saichek, 1998). It requires a temperature around 322 degree Celsius to burn the waste tire (Edeskar, 2006). Unfortunately, improper combustion process has a negative impact on the environment. The combustion process in the open space produces carbon dioxide that pollutes the air and endanger human life. Due to the stable shape the waste tires cannot be compressed to reduce its volume. It huge amount and stable properties, waste tires need special treatments to solve those problems. One of the treatments is utilized as material in concrete or civil construction.

Recently, some researchers tried to recycle waste tire in concrete structures by some methods. According to the good properties of waste tire such as durability and elasticity, tire rubber ash (TRA) as filler in the mortar was already explored in order to investigate the effect flexural strength (Al-akhras and Smadi, 2005). Tire chips were burned in an oven at heat of 850 degree Celsius for three days. Sand in the mortar was partially replaced by TRA at 2.5%, 5%, 7.5% and 10% by weight. The results show that flexural strength of TRA was higher than that of control mortar. Coarser chip of waste tires with particle

size of 0.29 mm and 0.59 mm was also used as a partial substitution of sand in concrete (Albano *et al.*, 2005). The results showed that the proportion of waste tires in concrete increases, the splitting tensile strength decreased when associated to the untreated rubber-concrete composite.

Furthermore, the longer and greater size of waste tires was investigated as reinforcement in concrete beam (Hankare, *et al.*, 2014). They applied waste tire dimension of 10 x 15 x 920 mm in reinforced concrete specimen. The dimension of the beam was 150 x 150 x 1000 mm. The result showed that flexural strength of waste tire reinforced beam is lower about 45% than the flexural strength of the steel reinforced beam. It is well understood because based on recent investigation (Maryoto, 2014a) indicated that the tensile strength of waste tires was only about 8 MPa and the strain was about 80%.

The capacity of flexural strength was also investigated to replace the steel bar reinforcement diameter 8 mm with the waste tire reinforcement without prestressed. Six specimens are utilized to observe the contribution of the waste tire in the concrete. The dimension of the specimen is 150 x 150 x 1000 mm. The variables of reinforcements are 2 steel bars, 2 waste tires and 1 steel bar, 4 waste tires and 1 steel bar, 6 waste tires, 9 waste tires and 10 waste tires. The result showed that the capacity of specimens with 10 waste tire reinforcement without prestressed force or compression force action is still lower than the specimen with the steel bar reinforcement (Maryoto, 2014b).

The effect of pre-stressed force on corrosion crack width in concrete was investigated (Maryoto, 2017). It shows that pre-stressed force contribute on crack width, even though the subvention is small. Furthermore, specific research in concrete with waste tire reinforcement and under pre-stressed loading which were located in the tension layers was carried out as well (Maryoto, *et al.*, 2015). They pulled the waste tire reinforcement up to 17% of its capacity. The result shows that the pre-stressed force assist significantly on the flexural strength. The method has linearity to Han *et al.* investigation (Aylie, *et al.*, 2015). They applied functionally graded concrete because layers of concrete in tension require low concrete strength to support external load.

In this work we extend the Maryoto *et al.* results (2015) for larger pre-stressed forces, i.e. 25%, 40% and 60%. Since rubber is well known for its capability to undergo large deformation, it is interesting to find the influence of such deformation to the behavior of concrete. Similar procedures are also conducted here. An additional finite element analysis (FEA) to (Maryoto, *et al.*, 2015) is done to find correlation among three parameters, i.e. mid-span displacement, pre-stresses load and bending load. This results are then compared to the actual measurements from the test.

High strain of waste tire has not been harnessed to escalate flexural strength of waste tire reinforced concrete beam. This work tries to investigate the effect of pre-stressed force due to extending of waste tire. After the waste tires are tensioned and then they are clamped and jacked using anchors on the end of concrete beam. Experimental work is conducted using six specimens which continue previous research. Finite element analysis is studied as well with same specimen in order to know the universal influence of waste tire as reinforced in concrete.

Experimental Work

Concrete is composed of cement type 1 as Ordinary Portland Cement, crushed stone with maximum diameter 10 mm from quarry stone in Banyumas region, natural sand from Merapi Mountain, Central Java and water from deep well around Laboratory of Civil Engineering, Jenderal Soedirman University. Analysis of physical properties of aggregates which are crushed stone and sand are conducted before arrange the mix proportion of concrete. Those preliminary tests involve sieve analysis, density of materials, specific gravity, clay content, and resistance to degradation of coarse aggregate. Moreover, mix design of concrete can be composed according to Indonesia National Standard SK-SNI.T 15-1990-03 (DPU, 1990) which refers to The British Mix Design Method. Compressive strength of concrete in this study is set around 15 MPa. Finally, by following the steps of Indonesia standard, the mix proportion of concrete is obtained as shown in Table 1.

Table 1. Mix proportion of concrete.

No	Material	Weight (kg/m ³)
1	Cement	360
2	Sand	775
3	Crushed stone	1070
4	Water	205

Specimens

Compressive strength of concrete is verified by using cylinder specimen with 150 mm of the diameter and 300 mm of the height. Quantity of the specimens is 3 pieces. Flexural strength of concrete is verified by using concrete beam with the dimension 150 x 150 x 1000 mm. Each type of specimens is represented by one concrete beam.

There are six specimens of concrete beam namely one concrete beams without waste tire reinforcement and five concrete beams with waste tire reinforcement. The five waste tire reinforced concrete beams are one specimen without pre-stressed force and four specimens with pre-stressed force which are applied using stretching the waste tire reinforcement with 17%, 25%, 40% and 60% elongation. The specimen is obtained by casting fresh concrete into the molding as shown in Figure 1.

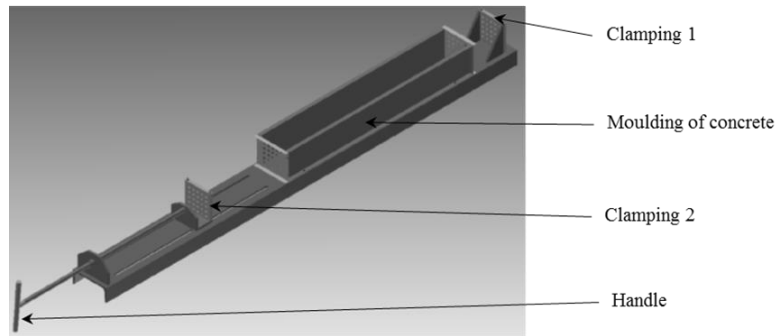

Figure 1. Moulding of concrete beam [3]

Steps of concrete casting in the molding are shown in Figure 2. The first step is inserting waste tire reinforcement 10 mm x 10 mm x 2000 mm in the first clamp at the end of molding and then tightening the clamping (Fig. 2a). Through the hole in the casting, end of the waste tire reinforcement is inserted and hold by another clamp (Fig. 2b). Rotate the handle in order to stretch the waste tire reinforcement until the strain target is reached (Fig. 2b). After installation of the casting of the concrete is ready, then fresh concrete is cast into the form (Fig. 2c). Release harden concrete beam from the form at the 3 days age. At the same time, jacking the waste tire reinforcement at the end of the concrete beams using anchorages. They are covered by using a wet mattress for 25 days (Fig. 2d). Finally, the flexural strength test is verified based on ASTM C 78 – 94 (Fig. 2e) (ASTM, 1996).



a. Tightening the waste tire on the first clamp (Maryoto, et al., 2015)



b. Installation of the waste tire on the second clamp



c. Finishing of specimens after casting of concrete



d. Curing of harden concrete specimens



e. Setting up of concrete beam before conducting the flexural strength test

Figure 2. Processes of concrete casting, curing and testing

Flexural Strength Test

The concrete beam specimen is set up based on ASTM C 78 – 94 (ASTM, 1996) as shown in Figure 3. Bring the load applying blocks in contact with the surface of the specimen at the third point and apply a

load between 3 and 6% of the estimated ultimate load. Applied the Load on the specimen continuously and without shock. The load applied is at a constant rate to the breaking point. When the fracture initiated in the tension surface within the middle third or the span length, calculated the modulus of rupture as Equation 1.

$$R = \frac{PL}{bd^2} \quad (1)$$

The modulus of rupture was calculated by Equation 2 if the fracture occurred in the tension surface outside of the middle third of the span length by not more than 5% of the span length.

$$R = \frac{3Pa}{bd^2} \quad (2)$$

where, R is modulus of rupture in Mega Pascal, P is maximum applied load indicated by the testing machine in Newton, L is the span length in mm, b is the average width of specimen of the fracture in mm, d is average of the depth of the fracture in millimeter and a is average of the distance between lines of fracture and the nearest support measured on the surface tension of the beam.

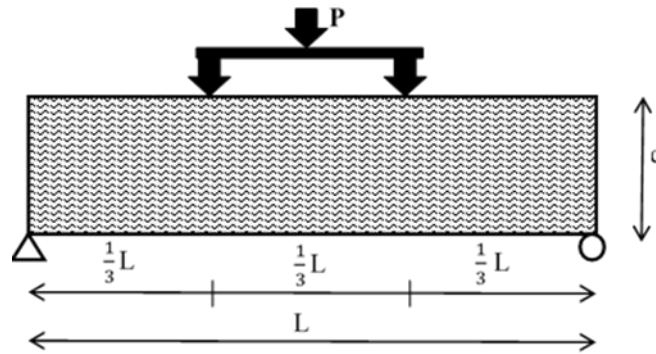

Figure 3. Set up of flexural testing specimen

Numerical Simulation

Based on previous research, finite element analysis (FEA) is also applied here using a limited version of the commercial FEA namely LISA which has the capability to model until 1300 nodes (Sonnenhof, 2013). Since the model in hand is linear and having non-complex boundary condition, this works is merely to support the further design of the respective specimens before their production stages instead of one-to-one validation on the experimental results. The latest will be the next research objective.

Mechanical properties of concrete that are the compressive strength f_c , the Poisson's ratio ν , tensile strength f_t and modulus of elasticity E are applied as input in LISA. The value of 0.2 is adopted to represent of the Poisson's ratio of concrete. The two last of mechanical properties is estimated according to Comite Euro-International du Beton – Federation Internationale de la Precontrainte CEB-FIP Model Code (Telford, 1990). The modulus of elasticity, E is considered based on Equation 3 below.

$$E_{ci} = E_{c0} \alpha_E \left(\frac{f_{ck} + \Delta f}{10} \right)^{1/3} \quad (3)$$

where : E_{ci} is the modulus of elasticity in Mega Pascal (MPa) at concrete age of 28 days, f_{ck} is the characteristic strength in MPa, Δf is equal to 8 MPa, E_{c0} is 21,5.10³ MPa and α_E is 1,0 for quartzite aggregates.

Meanwhile, the tensile strength of concrete in MPa is estimated for normal weight concrete from the characteristic compressive strength. When the concrete grade is less than and equal to C50, the following equation is used.

$$f_{ctm} = 0,3 \cdot (f_{ck})^{2/3} \quad (4)$$

where : f_{ck} is the characteristic compressive strength in MPa.

In this work, a special modeling and simulation procedure relied on FEA is used to overcome the node limitation above. By relying on a volume fraction homogenization method, the influenced of the tire reinforcement is smeared into solid brick elements. Three different meshes, as shown in Figure 4, to capture different material properties are built. First mesh is dedicated to model pure concrete not directly influenced by the waste tire reinforcement. Meanwhile, second mesh is constructed merely as the transition domain from the reinforcement and the pure concrete. In this mesh, trial-error processes to find a better approximation with respect to experimental results are performed. Finally, third mesh is dealt with requirement to represent behavior mostly of the tire reinforcement. Since this work considers only small strain and displacement, no hyper elastic model or finite strain kinematics are used throughout the simulation as commonly found in tire based material modeling and simulation. Consequently, the behavior of the tire materials herein will be assumed linear.

The procedure used to simulate the experimental results is described as:

1. Using the experimental results from the pure concrete tests without tire and pre-stress aforementioned, the concrete modulus of elasticity E_c for the simulation is calibrated.
2. The modulus E_c is then used to simulate the test results from concrete with tire reinforcement to find the best fit of transition modulus elasticity E_T . Furthermore, orthotropic material model of region in Fig.1(c) with tire-concrete modulus elasticity E_{rc} is also determined. There is no pre-stressed implemented here.
3. With E_c , E_T and E_{rc} in hand, the simulations of concrete with tire reinforcement are then executed for pre-stress forces related to the tire deformation of 17%, 25%, 40% and 60%.

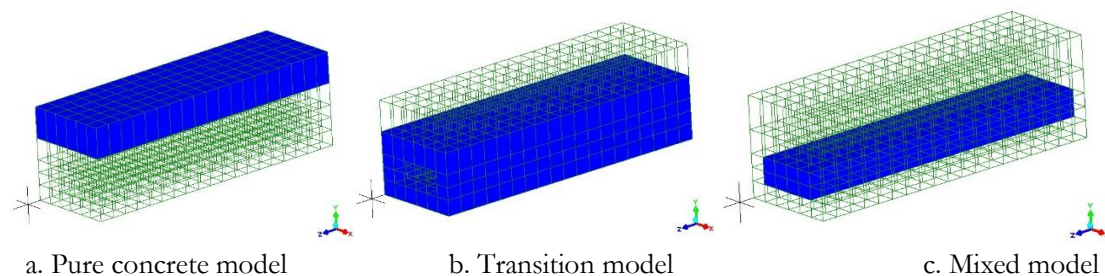

Figure 4. Three different material models represented in three different mesh domain for pure concrete (a), transition between concrete and the tire reinforcement (b) and mixed tire reinforcement in concrete (c) (Maryoto, et al., 2015)

Results and Discussions

Experimental Results

Preliminary tests of aggregate, which are crushed stone as coarse aggregate and mountain sand as fine aggregate were conducted according to Indonesia Standard (SNI) (BSN, 2000). The results of coarse aggregate tests are 3.54 grams/cm³ for density, 2.65 for specific gravity in saturated surface dry condition (SSD), 0.23% for clay content, 34% for resistance to degradation, and 6.3 for fineness modulus. Meanwhile, fine aggregate test obtained are 1.60 grams/cm³ for density, 2.71 for specific gravity in SSD condition, 2.96% for clay content and 2.63 fineness modulus to qualify the grade of sand. Those entire results meet with the Indonesia Standard (SNI) without any further treatments to increase the quality of aggregate. Based on those results, mix proportion of concrete, then are designed. The mix design is shown in Table 1. To ensure that the mix design is met with the compressive strength planning, three cylinders of concrete specimens are tested in the 28 days age. The results are 16.2 MPa, 16.4 MPa and 16.7 MPa. The average of compressive strength is 16.4 MPa and satisfy to the mix design.

Main experiments in this study is to verify the flexural strength capacity of the concrete specimen. After the specimen of concrete beams were completely cured, which were covered with wet mattress in the 28 days age, the flexural strength test is then conducted by using Universal Testing Machine. Table 2 shows the result of the flexural strength test.

Table 2 shows that the maximum load of NR is greater than WTR-0. This is because some of concrete area replaced by waste tire reinforcement. As the physical properties, waste tire has smaller compressive strength than concrete. On the other hand, waste tire reinforcement does not have pre-stressed force treatment. The effect of tensile strength capacity in concrete beam with waste tire reinforcement decrease

significantly. Furthermore, contrary effect appears in the specimens WTR-17, WTR-25, WTR-40, WTR-60 and specimen NR. This is due to contribution of pre-stressed force influence. Pre-stressed force increases maximum load around 5 kN of the concrete beam. The bonding force between waste tire reinforcements and concrete also contribute expressively on the enhancement of flexural strength capacity. It leads them to work in unity as a composite material. An additional advantage of the concrete beam using waste tire reinforcement is the presence of remaining load. It can be confirmed in the Table 2 column 4. Where, NR is non reinforcement concrete beam specimen, WTR is a concrete beam specimen with waste tire reinforcement, 0, 17, 25, 40 and 60 are waste tire reinforcement with 0%, 17%, 25%, 40% and 60% elongation.

Table 2. Result of flexural strength test

No	Code of Specimens	Maximum load (kN)	Remain load (kN)
1	NR	11.8	0
2	WTR-0	9.9	5
3	WTR-17	15.0	2
4	WTR-25	17.1	5
5	WTR-40	15.1	10
6	WTR-60	14.9	8

Figure 5 shows the processes of flexural test of the concrete beam. Crack occurs on the third middle spans of specimens. The type of destruction is a pure bending collapse and most certainly not contributed by the shear force. It can be clarified as well based on the figure that concrete beam without reinforcement (specimen NR) is downfall quickly after the maximum load is achieved. On the contrarily, concrete beam with waste tire reinforcement has a little capacity to confine specimen from total failure. It also can be observed that even though the occurrence of cracks more than 5 mm and continuously from bottom side connect to top side the concrete beam is constantly stable at the supports. This is because the strain of waste tire consumed in the concrete beam is only around 1% of remaining strain capacity. Based on the previous research (Maryoto, 2014a), the waste tire has strain capacity around 80%. It still has reserve strain approximately 19% because the maximum stretching in this study is 60%. With the safety reason in the laboratory, then the loading of flexural strength test is stopped due to the deflection of the concrete beam more than 20 mm.

Further observation on the specimen WTR-17, WTR-25, WTR-40 and WTR-60 show that the reducing of crack opening occurs when the external gravitation load is released. Those existences are led by pre-stressed force of waste tire reinforcements. It can be commonly understood as the processes of making specimens. The waste tire reinforcements are stretched, and after they reach the certain strain, they are jacked using clamp on the two ends of the beam. The jacking of them automatically transforms the tensile strength to the pre-stressed force on the concrete beam. The pre-stressed force always work on the concrete beam even though the concrete have been cracks totally.

According to Reinhardt in the recent investigation (Maryoto and Shimomura, 2015) stated that fracture energy (G_f) is calculated by using entirely area under curve after the concrete beam reach the maximum load in Newton per millimeter (N/mm). Figure 3 shows all graphs of the flexural test using Universal Testing Machine. The graphs correlate between displacement in millimeter as horizontal axes and vertical axes is a representation of load in kilo Newton. Corresponding to the Figure 6, the fracture energy of the specimen NR is 0. Conversely, the fracture energy of the specimen WTR-0 is more than 45 kN/mm. The similar result is indicated in specimen WTR-17, WTR-25, WTR-40 and WTR-60. They show that waste tire reinforced concrete has higher fracture energy than non-reinforced concrete. It also supports higher external load in the real structure. Even, when the cracks occur on concrete beam and the tensile strength drop suddenly until the lowest tensile strength, specimen WTR-17, WTR-25, WTR-40 and WTR-60 can build up the tensile strength. It grows step by step up to approximately 50% of the maximum tensile strength previously. The rising of tensile strength is generated by waste tire reinforcement. The property that is considered to lead this tendency is it elasticity. Waste tire is a pure elastic material. Unlike steel bar reinforcement, a maximum load never causes it to be plastic. As a consequence, the tensile strength of the specimen with waste tire reinforcement escalate again after a minimum tensile strength takes place on the concrete beam.



NR (Non reinforced concrete)
 (Maryoto, *et. al.*, 2015)



WTR-0 (Waste tire reinforced concrete with 0% tension)
 (Maryoto, *et. al.*, 2015)

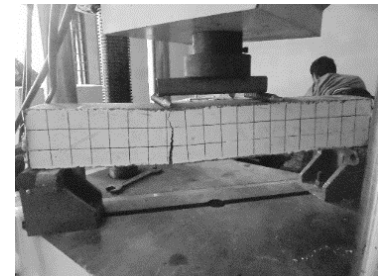

WTR-17 (Waste tire reinforced concrete with 17% tension) (Maryoto, *et. al.*, 2015)

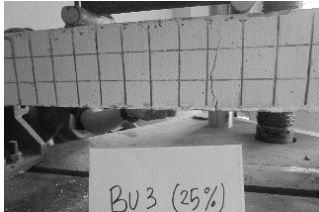

WTR-25 (Waste tire reinforced concrete with 25% tension)



WTR-40 (Waste tire reinforced concrete with 40% tension)

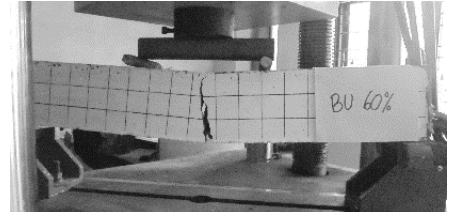

WTR-60 (Waste tire reinforced concrete with 60% tension)

Figure 5. Testing of flexural strength

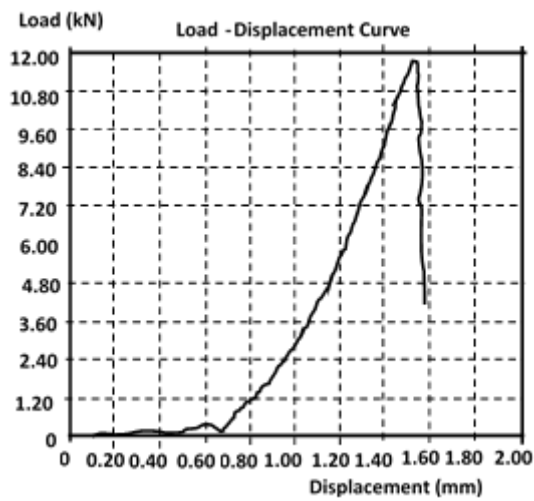

NR [3]

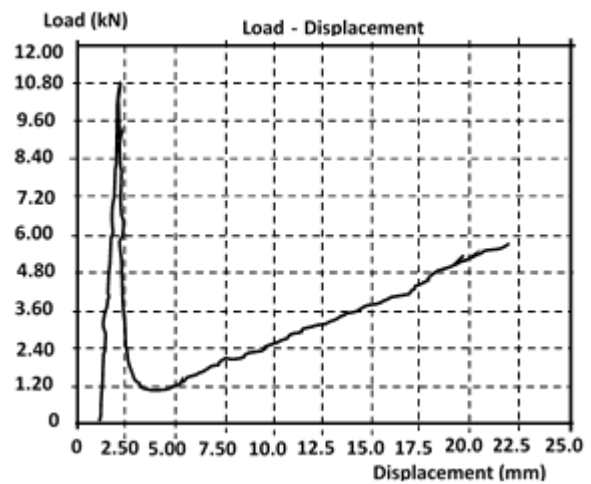

WTR-0 [3]

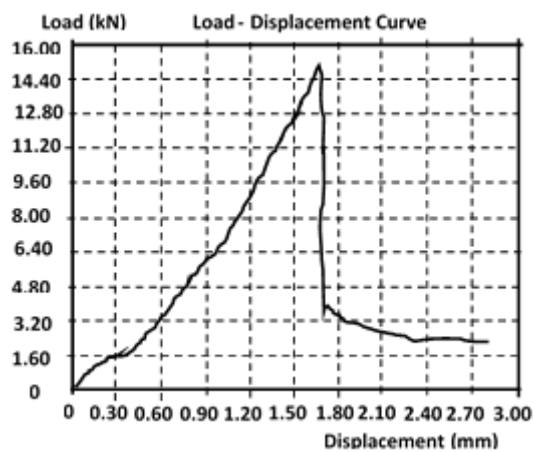

WTR-17 [3]

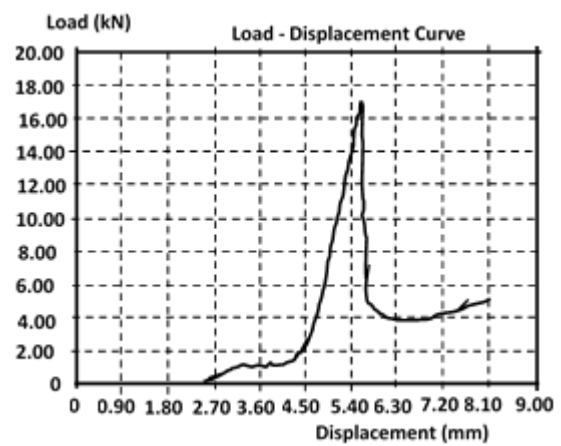

WTR-25

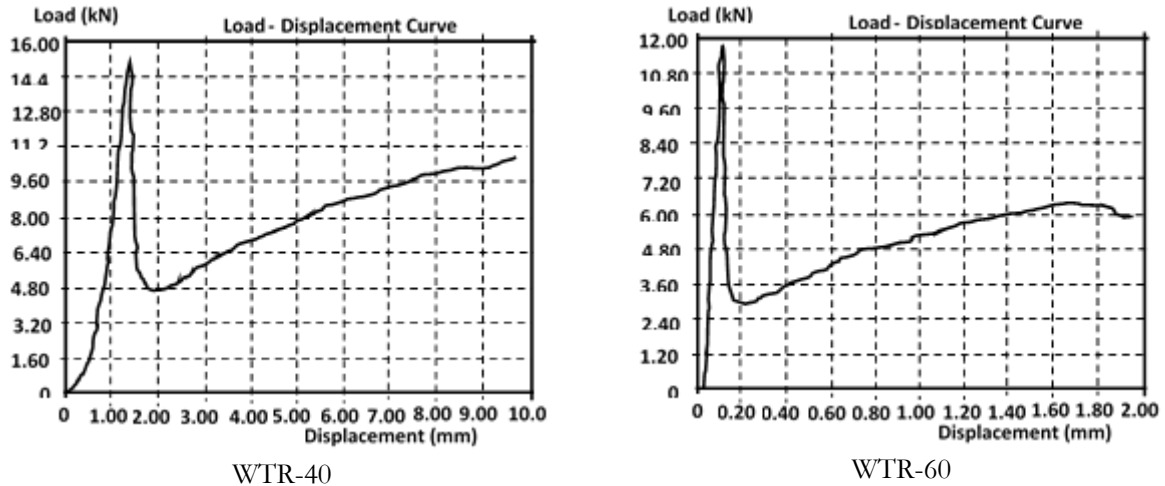

Figure 6. Relationship between displacement and load of the concrete beam specimen

Numerical Results

Figure 7 shows the result from the 3rd procedure associated with their respective experimental results. Here, by defining displacement d_L (mm) at the bending load point F_B (kN) as the ratio of them

$$K = \frac{d_L}{F_B} \tag{5}$$

is used for sensitivity analysis with respect to the experimental results as a function of the pre-stressed forces F_p .

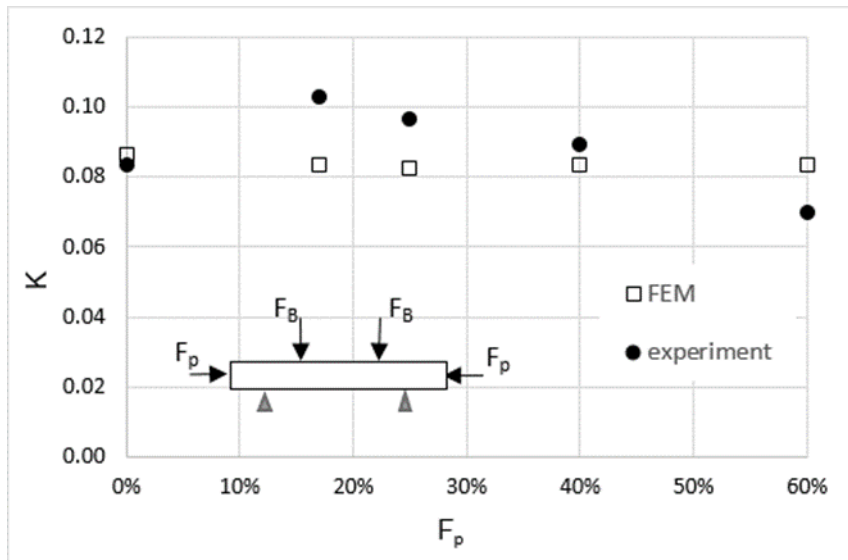

Figure 7. Sensitivity analysis of the FEM with respect to the experimental results

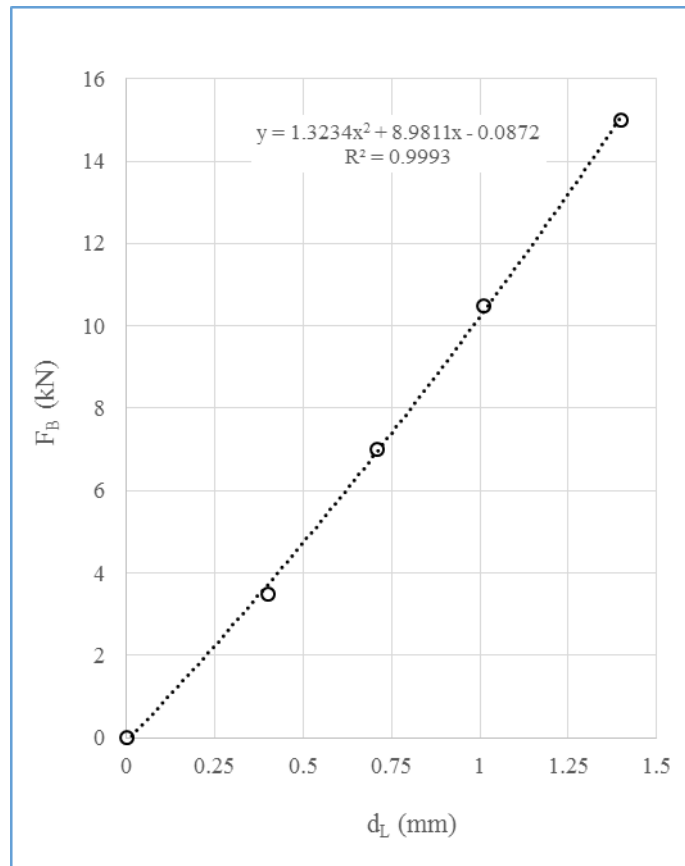

Figure 8. FEM simulation under pure bending load [3]

To obtain behavior of the FEM model in pure bending simulation, Figure 8 shows the relationship between bending load and displacement. Here, the lateral displacement behaves almost nonlinear with respect to loading according to the equation shown on it, which clearly indicates typical response of structure under bending load. On the other hand, the effect of pre-stresses on the specimen in Figure 9 shows an insignificant reduction of displacement due to low level pre-stress forces used. It is obvious from Figure 7 that the pre-stress forces do not influence bending behavior of the concrete with rubber reinforcement. As observed earlier also in (Eldin and Senouci, 1993), the stiffness of waste rubber is too low compared to pure concrete in wide spectrum of deformation. Hence, large deformation effect in rubber does not enough to influence the result above. However, dynamic properties of such composite material have been found better than pure concrete (Hernandes and Barluenga, 2003).

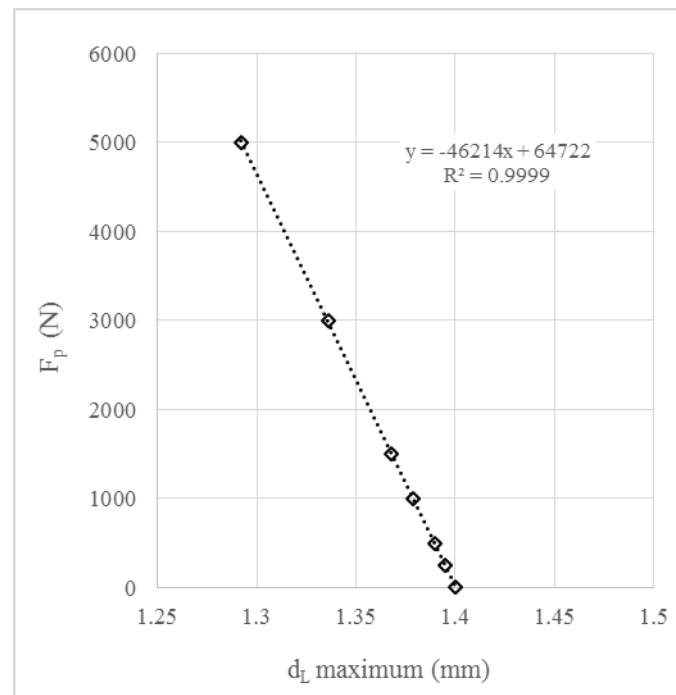

Figure 9. The effect of pre-stressed force to the displacement based on the simulation in Fig. 8 (Maryoto, *et al.*, 2015)

Conclusions

According to the above discussions some summaries can be concluded as follows:

1. Increasing of flexural strength can be achieved by using waste tire reinforcement in concrete beam with pre-stressed force. In this case, compression force as the effect of stretching the waste tire work on the two ends of concrete beam.
2. The waste tire reinforcement in concrete delay the entire collapse of concrete beam. This is commonly understood because it exists in concrete to support the external load. The loading only generates a little strain, which is still under strain of the waste tire capacity.
3. Numerical simulation has a little difference to the experimental result. This is because in the simulation, all elements can be modelled in same properties, but in the reality, it is very hard to be conducted.
4. Because rubber has much little stiffness compared to the concrete, large deformation on it can be omitted for designing composite waste tire-concrete material.

Acknowledgements

We acknowledge the financial support for this work from LPPM, Jenderal Soedirman University, Purwokerto, Central Java, Indonesia and funded through Hibah Penelitian Unggulan Perguruan Tinggi.

References

- Yang, S., Lohnes, R. A., and Kjartanson, H. Mechanical properties of granulated tires. 2002. *Geotech. Test. J.*, 25 (1): 44–52.
- Edeskar, T. Use of tyre shreds in civil engineering applications: technical and environmental properties. 2006. Lulea University of Technology, Sweden.
- Maryoto, A., Hermanto, N. I. S., Haryanto, Y., Waluyo, S. and Anisa, N. A. 2015. Influence of Prestressed Force in the Waste Tire Reinforced Concrete. *Procedia Engineering* 125: 638–643.
- Malek, K and Stevenson, A. 1986. The effects of 42 years immersion in sea water on natural rubber. *Journal of Materials Science* 21: 147–154.
- Reddy, K. and Saichek, R. 1998. Characterization and performance assessment of shredded scrap tires as leachate drainage material in landfills. The fourteenth international conference on solid waste technology and management.

- Al-Akhras, N. M. and. Smadi, M. M. 2004. Properties of tire rubber ash mortar. *Cement Concrete Composite* 26(7): 821–826,
- Albano, C., Camacho, N., Reyes, J., Feliu, J. L., and Hernandez, M. 2005. Influence of scrap rubber addition to portland I concrete composites : destructive and non-destructive testing. *ICSST/5*: 439–446.
- Hankare, A. V., Patil, A. N., Deshmukh, A. R., Engineering, C., and Warananagar, T. 2014. Flexural Strength of Normal Beam by Replacing Tension Reinforcement as Waste Tyre Preparation of specimen : Introduction : Specimen details : Material properties : Flexural testing. *Int. J. Eng. Research* 5013(3): 330–332.
- Maryoto, A. 2014. Studi kelayakan penggunaan limbah ban bekas sebagai tulangan beton. in *Konferensi Teknik Sipil ke-8: Mat.* 104–109.
- Maryoto, A. 2014b. Kapasitas lentur balok beton bertulangan limbah ban. in *Percepatan Desa berdikari melalui pemberdayaan masyarakat dan inovasi teknologi*: 1–8.
- Maryoto, A. and Shimomura, T. 2017. Effect of pre-stressed force and size of reinforcement on corrosion crack width in concrete member. *Journal Engineering Science and Technology, Taylor University Malaysia*, 12(7): 1–14 (in Press).
- Aylie, H., Gan, B. S., As'ad, S. and Pratama M. M. A. 2015. Parametric Study of the Load Carrying Capacity of Functionally Graded Concrete of Flexural Members. *Int. J. Eng. Technol. Innov.* 5(4): 233–241.
- DPU, Standar Tata Cara Pembuatan Rencana Campuran Beton Normal.1990. SK-SNI T-15-1990-03. Jakarta, Indonesia: Departement Pekerjaan Umum.
- ASTM. ASTM Standard Section 4 for Construction, Vol for concrete and aggregate 04.02. in *ASTM*, 1996: 31–33.
- Sonnenhof, H. 2013. *Lisa - Finite Element Technologies, Ver. 8.0.0.* Sonnenhof Holding.
- Telford, T. 1990. *Comite Euro Internationale du Beton - Federation Internationale de la Precontrainte.* CEB-FIP Model Code.
- BSN, Standar Nasional Indonesia, SNI 03-2834-2000, Tata cara pembuatan rencana campuran beton normal. Indonesia, 2000.
- Maryoto A. and Shimomura, T., 2015. Prediction of Crack Width Due to Corrosion of PC Tendon in Prestressed Concrete Structures. *Civil Engineering Dimension* 17(2): 67–75.
- Eldin, N. N. and Senouci, A. B. 1993. Rubber-tire particles as concrete aggregate. *Journal Material Civil Engineering. ASCE* 5(4): 478–496.
- Hernández-Olivares, F. and Barluenga, G. 2003. Fire performance of recycled rubber-filled high-strength concrete. *Cement Concrete Res.* 34(1): 109–117.