

## Design and performance analysis of a twin T-bridge RC harmonic oscillation generator with an operational amplifier

Boyan Karapenev

Department of the Communication Equipment and Technologies, Technical University of Gabrovo, Bulgaria

---

### Article Info

#### Article history:

Received Nov 9, 2018

Revised Apr 25, 2019

Accepted May 20, 2019

---

#### Keywords:

Analysis

Design

RC harmonic oscillation

generator

Studies

Twin T-bridge

---

### ABSTRACT

This paper presents the special features of harmonic generators and their widespread use and in particular the design, simulation and experimental studies of a twin T-bridge RC generator with an operational amplifier. The results obtained are analyzed and compared. For the particular implementation, the frequency error varies from 4 % in experimental studies to 6.7 % in the simulation, and in this case an average value of 5.35 % can be assumed.

Copyright © 2019 Institute of Advanced Engineering and Science.  
All rights reserved.

---

### Corresponding Author:

Boyan Karapenev,  
Department of the Communication Equipment and Technologies,  
Technical University of Gabrovo,  
Ul. "Hadji Dimitar" 4, 5300 Gabrovo Center, Gabrovo, Bulgaria.  
Email: bkarapenev@tugab.bg

---

## 1. INTRODUCTION

The development of technology over the last decades has led to the need to employ electronics in an increasing proportion of human activities. This necessity induces a constant improvement of the existing and the creation of new electronic equipment, where electronic generators find a wide application as a primary source of electrical signals.

Electronic generators are also very useful in communications [1-3]. They are the basis for creating the modern resources for radio broadcasting and radio reception based on the super heterodyne principle - radio, television, telecommunications, etc. They are also used in electronic circuits associated with electromagnetic wave propagation, induction heating and many more. They are also disseminated in electronic circuits of automated instruments for control of production and other processes, in medical, measuring, musical equipment, etc.

This determines the wide variety of schemes and constructive solutions. The common thing among them is that they are designed to convert DC power from the power source into non-stop electric oscillations with certain parameters.

The main topologies of the harmonic oscillation generator are based on the type of the elective circuit - LC and in particular quartz and RC generators.

A transistor, which is most frequently a field transistor, is included in one of the bridge arms in the structure of recent RC generators with twin T-bridge. The voltage to control the transistor and automatically maintain the amplitude and oscillation frequency is obtained by an amplitude detector with a diode. Thereby Voltage-Controlled Oscillators (VCO) are realized [4].

In scientific publications of recent years, e.g. [5-18], no in-depth studies and analyses of the RC harmonic oscillation generators as well as their selective circuits are available.

## 2. REPRESENTATION

The widespread use of generators leads to the need of greater accuracy and stability, and for this purpose, the schematic solutions and building elements are continually being improved. Twin T-bridge RC harmonic oscillation generators are classified as those with selective frequency-determining circuit and minimum transmission coefficient and zero-offset feedback for the generated frequency  $f_0$ . The twin T-bridge as a passive unit according to its amplitude-frequency response (AFR), is a band-stop filter.

### 2.1. Design of a twin T-bridge harmonic oscillation generator with an operational amplifier

Output data for design of the twin T-bridge harmonic oscillation generator:

- generated frequency  $f_0 = 1$  kHz;
- output voltage  $U_0 = 10$  V;
- load resistor  $R_L = 1$  k $\Omega$ .

A schematic circuit of a twin T-bridge RC oscillation generator with an operational amplifier (OA), with the calculated and chosen values of the composed components is shown in Figure 1. The resistor  $R_5$  is connected to the non-inverting input of the OA to reduce its output error caused by the existing input bias current IIB.

This twin T-bridge oscillator circuit gives the reduced distortion output and the desired tuned frequency output. As it is a combination of low-pass  $R_1$ - $C_3$ - $R_2$  and high-pass  $C_1$ - $R_3$ - $C_2$  filters, the circuit is able to select a wide frequency range as notch filter and it attenuates a very narrow band of frequency. The resistors  $R_1$  and  $R_2$  introduce a positive feedback. The twin-T network introduces 0 phase shift and its output voltage is minimum at  $f=f_0$ . The twin T-bridge oscillator can drive resistive, inductive and capacitive loads. The oscillator frequency cannot be varied. It is a single frequency oscillator.

The widespread and universally applied  $\mu$ A741 will be chosen as an OA of the twin T-bridge RC oscillation generator. Its main catalog parameters are presented in Table 1 [19].

Table 1. A main catalog parameter of OA  $\mu$ A741

| OA          | Parameters         |            |                       |                 |                    |             |
|-------------|--------------------|------------|-----------------------|-----------------|--------------------|-------------|
|             | $R_i$ , M $\Omega$ | $C_i$ , pF | $R_{sf}$ , M $\Omega$ | $A_0$           | $R_o$ , M $\Omega$ | $f_t$ , MHz |
| $\mu$ A741  | 2                  | 1.4        | 20                    | $2 \times 10^5$ | 75                 | 6           |
| $\mu$ A741A | 6                  | 1.4        | 60                    | $5 \times 10^4$ | 75                 | 4           |

The values of the twin T-bridge elements connected to the OA in the RC generator circuitry,  $R_1$ - $R_2$ - $C_1$ - $C_2$ - $R_3$ - $C_3$  are determined on the basis of the following dependencies: the values of  $R_1=R_2$  and  $C_1=C_2$  are chosen [20], and  $R_3=R_1/2$  and  $C_3=2 \cdot C_1$ :

-  $R_1=R_2=15$  k $\Omega$  and  $C_1=C_2=10$  nF are chosen, and  $R_3=R_1/2=7.5$  k $\Omega$ . For  $R_3$  a standard value of 6.8 k $\Omega$  is selected, and  $C_3=2 \cdot C_1=20$  nF the adopted standard value 22 nF;

- The values of  $R_4$  and  $R_5$  are calculated by

$$R_4 = \frac{R_1 + R_2}{2} = \frac{15 \cdot 10^3 + 15 \cdot 10^3}{2} = 15 \text{ k}\Omega, \quad (1)$$

$$R_5 = \frac{(R_1 + R_2) \cdot R_4}{R_1 + R_2 + R_4} = \frac{(15 \cdot 10^3 + 15 \cdot 10^3) \cdot 15 \cdot 10^3}{15 \cdot 10^3 + 15 \cdot 10^3 + 15 \cdot 10^3} = 10 \text{ k}\Omega. \quad (2)$$

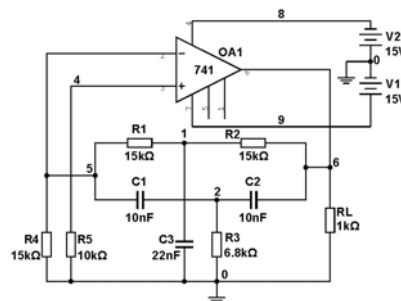

Figure 1. A circuit of twin T-bridge RC oscillation generator with an OA

## 2.2. Simulation studies of the designed twin T-bridge RC oscillation generator with an OA

The circuit of the designed twin T-bridge RC oscillation generator with an OA of Figure 1 was introduced into the MultiSIM working environment of Circuit Design Suite package and simulation studies have been done on it.

The measured values of the parameters of the generated output signal with the instruments Frequency counter and Multimeter are 1.067 kHz and 10.44 V, respectively.

The oscillogram with the generated oscillations at the output of the RC generator is shown in Figure 2. It clearly shows the outgoing transition process and sets the parameters of the output signal: frequency  $f_0 = 1.056$  kHz and voltage  $u_0 \approx 14.1$  V.

The obtained results of the carried-out DC operating point analysis of the twin T-bridge RC generator are presented in Table 2. From the voltage values in the indicated nodes which have dimensions mV and  $\mu$ V, it is established that the OA has no DC operating point mode.

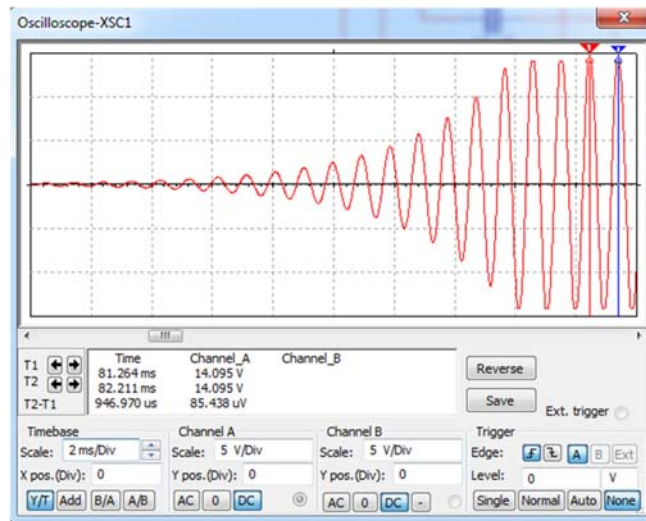

Figure 2. Oscillogram of the output signal of the designed twin T-bridge RC harmonic oscillation generator

Table 2. DC operating point of the OA at twin T-bridge RC harmonic oscillation generator

| Variable | Operation point value |
|----------|-----------------------|
| 1 V(1)   | 2.02088 m             |
| 2 V(2)   | 0.00000               |
| 3 V(4)   | -538.18893 u          |
| 4 V(5)   | 491.18255 u           |
| 5 V(6)   | 3.55058 m             |
| 6 V(8)   | -15.00000             |
| 7 V(9)   | 15.00000              |

The amplitude-frequency (AFR) and phase-frequency (PFR) responses of the twin T-bridge as a passive unit of the structure of the RC harmonic oscillation generator are shown in Figure 3. From the first response it is established that the voltage transmission coefficient is the smallest precisely for the generator operating frequency of 1 kHz and that the coefficients are different at low- and high- frequencies. From the PFR is determined the phase shift between the input and output signals of the twin T-bridge is  $(-107.3^\circ)$  for  $f_0 = 1$  kHz.

From the simulation studies performed, the relative error between the realized and the set operating frequency can be determined with a value  $\mathcal{E}_f = 6.7\%$ , which in this case coincides with the relative instability parameter of the generated frequency  $\Delta f/f_0 = 0.067$ .

The relative instability of the generated frequency  $\Delta f/f_0$  is one of the most important parameters of the harmonic oscillation generators. It is defined by ratio  $(f-f_0)/f_0$  where  $f$  is the real (Measured) and  $f_0$  - the nominal frequency (1 kHz). The lower the  $\Delta f/f_0$  value, the more accurate the obtained generator. Various direct and

indirect destabilizing factors affect the accuracy of the generated frequency. Temperature coefficients of resistance variation of resistors  $\alpha_R$ , of capacitance of the capacitors  $\alpha_C$  as well as those of the temperature dependent parameters of OA -  $\alpha_{U_{io}}$  (input offset voltage),  $\alpha_{I_{io}}$  (input offset current) and  $\alpha_{I_{ib}}$  (input bias current) can be referred to as direct and changes in complex load impedance, pulsations of supply voltage, influence of external fields as indirect.

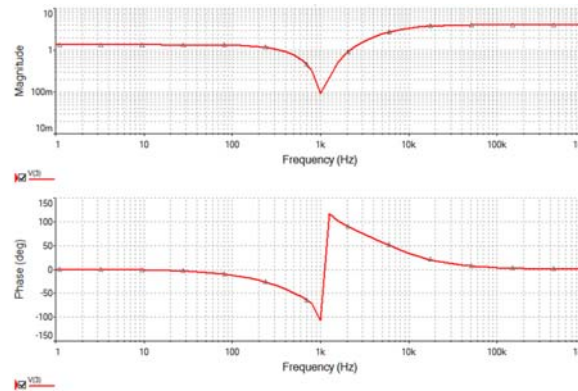
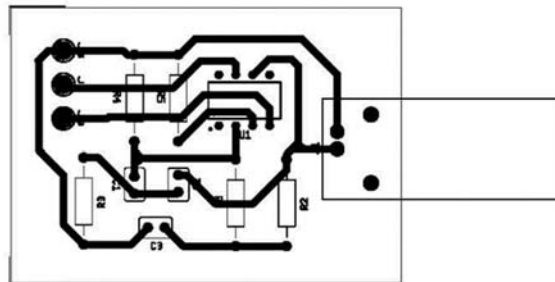

Figure 3. AFR and PFR of the twin T-bridge as a passive unit of the structure of the RC harmonic oscillation generator

### 2.3. Experimental studies of the designed twin T-bridge RC oscillation generator with an OA

Technical documentation of the designed twin T-bridge RC generator with an OA has been developed using the UltiBOARD module of the Circuit Design Suite package by which a laboratory model has been implemented.

The assembly drawing of the developed RC generator is presented in Figure 4 and in Figure 5 is presented its 3D-image.



The transfer characteristics of the twin T-bridge as a passive unit for 1.4 kHz and 0.8 kHz operating frequencies are presented in Figure 6. It is established, that they are relatively linear with a minimum deviation in the initial stretch. The characteristic at the 0.8 kHz operating frequency has greater linearity. The transmission coefficient is in the order of 0.12.

The amplitude-frequency responses (AFR) of the twin T-bridge as a passive unit for 1.14 V and 1.8 V operating voltages are presented in Figure 7. It has been found from the AFR that the twin T-bridge performs the function of a band-stop filter. The minimum transmission coefficient for input voltage 1.8 V is exactly at the frequency of 1 kHz as the attenuation is greater -33.4 dB, and for  $u_i=1.14$  V - at the frequency of 0.9 kHz and attenuation -23.1 dB.

The obtained oscillograms at the output of the twin T-bridge RC oscillation generator with an OA are presented in Figures 8 and 9, respectively. Amplitude value is 13.7 V, the effective value measured with a multimeter is 10.22 V, frequency 1.04 kHz and sinusoidal form of the output signal.

The measured DC voltages (DC operating point) at the indicated nodes of the twin T-bridge RC generator with an OA are presented in Table 3.

Table 3. A DC operating point in the indicated nodes of the twin T-bridge RC oscillation generator with an OA

| Node No  | 1     | 2                    | 4                      | 5            | 6    |
|----------|-------|----------------------|------------------------|--------------|------|
| $U_n, V$ | 0.116 | $0.8 \times 10^{-3}$ | $-10.3 \times 10^{-3}$ | $46.10^{-3}$ | 0.19 |

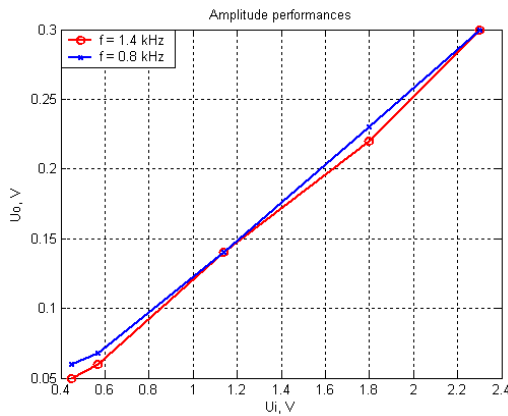

Figure 6. Transfer characteristics of the twin T-bridge for operating frequencies 1.4 kHz and 1.1 kHz

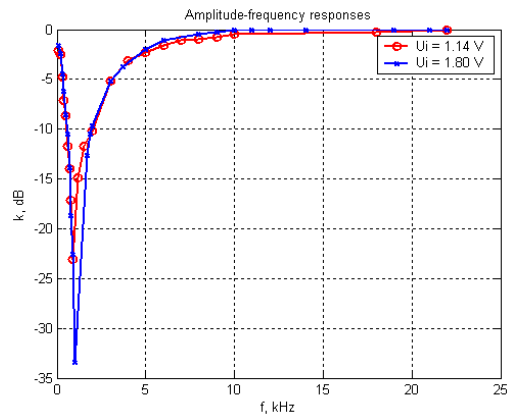

Figure 7. AFR of the twin T-bridge in a normalized form

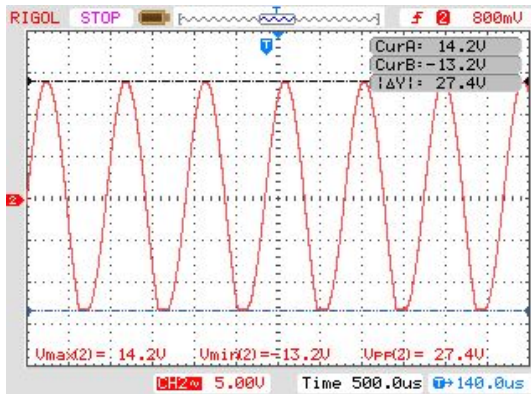

Figure 8. Oscillogram of the generated signal by a twin T-bridge RC oscillation generator - amplitude

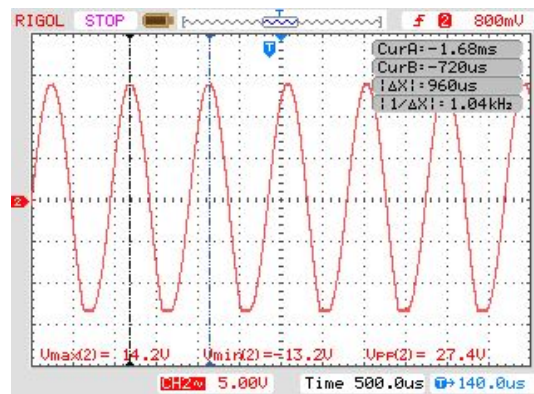

Figure 9. Oscillogram of the generated signal by a twin T-bridge RC oscillation generator - frequency

From the minimum voltage values in nodes 2, 4 and 5, it is established that the OA has not been provided with DC operation point mode.

In the practical implementation and the performed experimental studies of the designed twin T-bridge RC harmonic oscillation generator with an OA, the relative error between the realized and the set operating frequency can be determined with a value  $\mathcal{E}_f = 4\%$  and the relative instability parameter of the generated frequency  $\Delta f/f_0 = 0.04$ .

The ratio  $\Delta f/f_0$  has a relatively high value in the concrete practical implementation since the deviation of +40 Hz regarding the operating frequency  $f_0=1$  kHz in the low-frequency range is high. This is mainly due to the manufacturing tolerances of the passive elements used. The  $\Delta f/f_0$  value can be reduced by selecting the resistors and capacitors with their exact value and the requirement that they have a low tolerance. Because in the particular circuit of a generator with twin T-bridge a RC circuit with low selectivity is used for the relative frequency instability value  $\Delta f/f_0$  can be assumed to be the average of the 4% obtained in the experimental studies and 6.7% in the simulation and it is of the order of 5.35%.

### 3. CONCLUSION

The harmonic oscillation generators are used to generate signals in the frequency range from several Hz to MHz. Operational amplifiers as active elements are used for low frequencies and the realization of a higher amplitude of the output signal which can reach up to  $U_0=U_{CC}-(2-3) V$ .

Although the selectivity of RC generators is considerably smaller, they have some advantages: smaller sizes, suitable for integral implementation, they are not affected by dissipated magnetic fields, low cost, they are easily embedded in hybrid integrated circuits. However, by frequency stability, they are considerably inferior to other types of generators - LC and in particular the quartz generators.

The simulated and experimental results are presented for the design circuit of the twin T-bridge RC harmonic oscillation generator with an OA - main parameters of generated oscillations and oscillograms. A comparative assessment was made both between them and the set output frequency. It is established that the obtained relative difference between the realized and set operating frequencies in the experimental studies is lower than in the simulation.

For the designed and implemented circuit of the twin T-bridge RC harmonic oscillation generator with an OA, the error in the realized frequency changes from 4% in the experimental studies to 6.7% in the simulation and in this case it can be assumed as an average value of 5.35%.

Earlier, a comparative assessment has been made between the simulation and experimental studies obtained from the implementations of other circuits of RC generators with transistors and OA. It is found that in each case the generated frequency does not match the set frequency. In practice, it can be assumed that the average error in the implementation of the RC harmonic oscillation generators is in the range of 5-10%. The most accurate are RC generators with twin T-bridge, and the largest deviation from the set frequency have RC generators with phase-shifting group.

The harmonic oscillation generators are used in radio transmitters to implement an amplitude or frequency modulation of low-frequency (information) signals, radio receivers and measurement techniques, to form test signals for other electronic circuits and devices, electronic-computing equipment, electronic amplifier testers, etc.

### REFERENCES

- [1] Karapenev, B., "A comparative assessment between the obtained parameters from the studies of RC harmonic generators," Proceedings II, International Scientific Conference UNITECH'15, ISSN 1313-230X, pp. 76-80. 20-21, Gabrovo, Nov, 2015.
- [2] Koutsarov, St., *55 practical circuits of electronic filters*. Sofia, Technika Publishing house, 1984.
- [3] Koutsarov, St., *Non-inductive electronic filters*. Sofia, Technika Publishing house, 1977.
- [4] Filanovsky I. M and Fortier, G.J., "Fast amplitude control in twin-T bridge RC oscillators," *Electronics Letters*, vol 21, pp. 791-792, 1985.
- [5] E. M. Drozdova and T. I. Boldyreva., "Harmonic RC-oscillators with automatic amplitude control system," *2017 Systems of Signal Synchronization, Generating and Processing in Telecommunications (SINKHROINFO)*, pp. 1-5, Kazan, 2017.
- [6] E. M. Drozdova., "Circuits and methods for RC-oscillator's mode and noise phase calculation," *19th International Conference of Undergraduate and Postgraduate Students Radioelectronics Electrical and power engineering*, pp. 20, 2013.
- [7] V. N. Kuleshov, T. I. Boldyreva, A. A. Perfilov and E.M. Drozdova., "Noise characteristics of harmonic RC-oscillators with a band-stop filter," *Radiotekhnika*, (10), pp. 51-55, Moscow, 2013.

- [8] D. Jurisic, N. Mijat & G. S. Moschytz., "Low-sensitivity active-RC filters using impedance tapering of symmetrical bridged-T and twin-T networks," *2005 IEEE International Symposium on Circuits and Systems*, vol. 1, pp. 808-811, Kobe, 2005.
- [9] M. Lapinoja and T. Rahkonen, "A new low-noise active RC oscillator," *Proceedings of 40<sup>th</sup> Midwest Symposium on Circuits and Systems. Dedicated to the Memory of Professor Mac Van Valkenburg*, Sacramento, vol. 1, pp. 350-353, CA, USA, 1997.
- [10] Mancini Ron and Palmer Richard, *Application Report SLOA060: Sine-Wave Oscillator*. Texas Instruments Inc. Retrieved Aug 12, 2015.
- [11] Aiman Zakwan Jidin, Irna Nadira Mahzan, A. Shamsul Rahimi A. Subki, Wan Haszerila & Wan Hassan, "Improve performance of the digital sinusoidal generator in FPGA by memory usage optimization," *International Journal of Electrical and Computer Engineering (IJECE)*, vol. 9(3), pp. 1742-1749, Jun, 2019.
- [12] Jim Lepkowski and Christopher Young., *Designing RC Oscillator Circuits with Low Voltage Operational Amplifiers and Comparators for Precision Sensor Applications*. Application note AND8054/D, <https://www.onsemi.com/pub/Collateral/AND8054-D.PDF>
- [13] Jianxing Dai., *Analysis and design of a high-frequency RC oscillator suitable for mass production*, Linköping University, 2017, <https://liu.diva-portal.org/smash/get/diva2:1110326/FULLTEXT01.pdf>
- [14] H. Wang and P. P. Mercier., "A Reference-Free Capacitive-Discharging Oscillator Architecture Consuming 44.4 pW/75.6 nW at 2.8 Hz/6.4 kHz," *IEEE Journal of Solid-State Circuits*, vol. 51(6), pp. 1423-1435, Jun, 2016.
- [15] Filanovsky, I. M and A. STROMSMOE, K., "Amplitude control in a twin-T bridge RC-oscillator using a window comparator," *International Journal of Electronics - INT J ELECTRON*, vol. 61(2), pp. 197-206, 1986.
- [16] Kaewpoonsuk Anuchak and Katman Ratchanoo, "Amplitude Control of Twin-T and Phase-Shift Oscillators Based on Direct Feedback Control Technique," *NU Science Journal*, vol. 10, pp. 10-17, 2013.
- [17] Maneechukate Thongchai, Koseeyaporn Jeerasuda, Wardkein Paramote, & Koseeyaporn Poolsak, "Wide-band amplitude control of the second-order oscillator circuit," *Aeu-international Journal of Electronics and Communications - AEU-INT J ELECTRON COMMUN*, vol. 62, pp. 666-673, 10.1016/j.aeue.2007.08.010, 2008.
- [18] Sang Hou, An., "Oscillation amplitude control for the bandpass-type sinusoidal oscillator over a wide frequency range," *International Journal of Electronics - INT J ELECTRON*, vol. 92(2), pp. 99-108, 2005.
- [19] Online Available, <https://www.alldatasheet.com/datasheet-pdf/pdf/25555/stmicroelectronics/ua741.html>
- [20] Manolov, St and Ch. Tihchev., *Generators. Sofia*, Technika Publishing house, 1982.