

# Comparison Analysis of Model Predictive Controller with Classical PID Controller for pH Control Process

V.Balaji<sup>1</sup>, Dr. L.Rajaji<sup>2</sup>, Shanthini K.<sup>3</sup>

<sup>1</sup>Department of Electrical Engineering, Singhania University, Pachheri Bari, Rajasthan, India

<sup>2,3</sup> ARM College of Engineering and Technology, MaraiMalai Nagar, Chennai, India

e-mail: balajiee79@gmail.com

## Abstract

*pH control plays a important role in any chemical plant and process industries. For the past four decades the classical PID controller has been occupied by the industries. Due to the faster computing technology in the industry demands a tighter advanced control strategy. To fulfill the needs and requirements Model Predictive Control (MPC) is the best among all the advanced control algorithms available in the present scenario. The study and analysis has been done for First Order plus Delay Time (FOPDT) model controlled by Proportional Integral Derivative (PID) and MPC using the Matlab software. This paper explores the capability of the MPC strategy, analyze and compare the control effects with conventional control strategy in pH control. A comparison results between the PID and MPC is plotted using the software. The results clearly show that MPC provide better performance than the classical controller.*

**Keywords:** pH control, PID, MPC, FOPDT, matlab

## 1. Introduction

The Process control theory is evolving and new types of controller methods are being introduced. PID controllers are commonly used due to its simplicity and effectiveness. In most of the industries PID controllers are used. Still there is no generally accepted design method for this controller. In 1970's MPC controller has been introduced as a way of controlling a wide range of processes. Now a day's control systems engineers in the industry are adopting computer aided control systems design for modeling, system identification and estimation. These made a path to study MATLAB software. By adopting simulations the students may easily visualize the effect of adjusting different parameters of a system and the overall performance of the system can be viewed. In this paper it is demonstrated how to create a model predictive control for a first order system with time delay in a MATLAB Simulink and also explains the difference between MPC and conventional controller. pH control plays a vital role in the process industry. The traditional method is to use classical PID method and the advanced control strategy includes Model Predictive Controller. In this paper the tuning has been done using Z-N Method and results have been compared between, PID and Model Predictive method.

## 2. Model Predictive Control

Model predictive control (MPC) has become a standard technology in the high level control of chemical processes. MPC or receding horizon control is a form of control in which the control action is obtained by solving on-line, at each sampling instant, a finite open-loop optimal control problem, using the current state of the plant as the initial state; the optimization yields an optimal control sequence in which the first control move is applied to the plant.

Here the controller tries to minimize the error between predicted and the actual value over a control horizon and the first control action is being implemented. Model predictive controllers rely on dynamic models of the process, most often linear empirical models obtained by system identification. MPC is also referred to as receding horizon control or moving horizon control (Qin and Badgwell, 2003).[3]

Figure 1 shows the behavior of an MPC system can be quite complicated, because the control action is determined as the result of the online Optimization problem. The problem is constructed on the basis of a process model and process measurements. Process

measurements provide the feedback (and, optionally, feed-forward) element in the MPC structure. Figure 1 shows the structure of a typical MPC system feed-forward) element in the MPC structure.

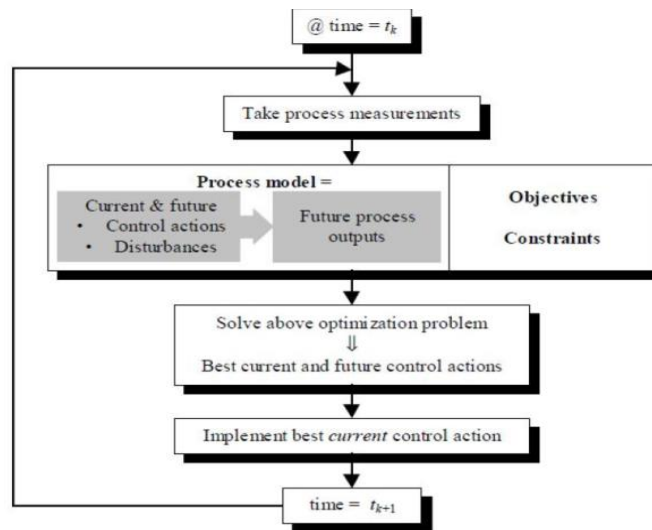

Figure 1. Model Predictive control Scheme

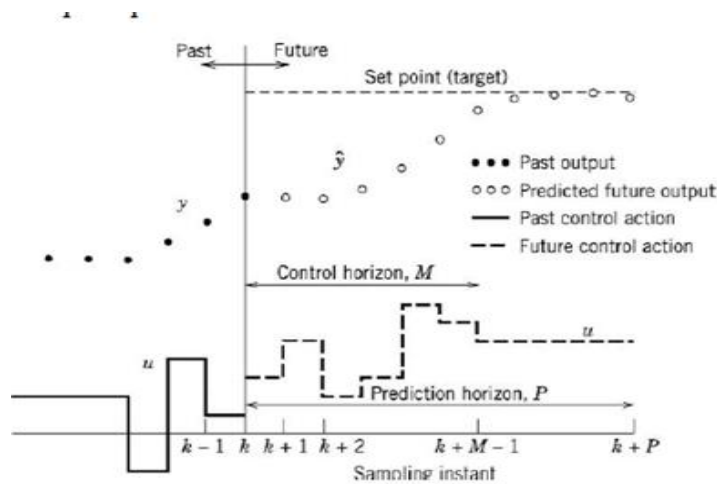

Figure 2. Basic concept of MPC [1]

**2.1. The Receding Horizon**

The control calculations are based on future predictions as well as current measurements. Future values of output variables are predicted using a dynamic model of the process and current measurements. Fig. 2 shows the concept of prediction horizon and control horizon.

**2.2. Prediction and Control Horizons**

Prediction horizon has a length equal to the number of samples in future for which the MPC controller predicts the plant output [1]. Prediction (P) is typically as far ahead as two to three times the dominant time constant of the system. Suppose the process is sampled at say one twentieth of that time constant: the output prediction horizon could then be up to some 60

steps ahead [2]. The length of control horizon is equal to the number of samples within the prediction horizon where the MPC controller can affect the control action [1].

### 2.3. Receding Horizon Approach

(i) At the  $k$ th sampling instant, the values of the manipulated variables,  $u$ , at the next  $M$  sampling instants,  $\{u(k), u(k+1), \dots, u(k+M-1)\}$  are calculated. (ii) This set of  $M$  —control moves is calculated so as to minimize the predicted deviations from the reference trajectory over the next  $P$  sampling instants while satisfying the constraints. (iii) Typically, an LP or QP problem is solved at each sampling instant. Then the first —control move,  $u(k)$ , is implemented. (iv) At the next sampling instant,  $k+1$ , the  $M$ -step control policy is re-calculated for the next  $M$  sampling instants,  $k+1$  to  $k+M$ , and implement the first control move,  $u(k+1)$ . (v) Then Steps 1 and 2 are repeated for subsequent sampling instants.

### 3. Experimental Setup

The pH process is adjusted by controlling the flow rate of ammonia. This action adjusts the flow rate of the Ammonia, thus the input to the controller is the pH reading of the mixing vessel which is compared against the required set point. At the same time the output voltage obtained from the controller is used to adjust the solenoid valve or motorized valve to control the Ammonia flow rate. This output tends to maintain the mixing vessel pH to a desired value. The Figure 3 shows the pH controlling process.

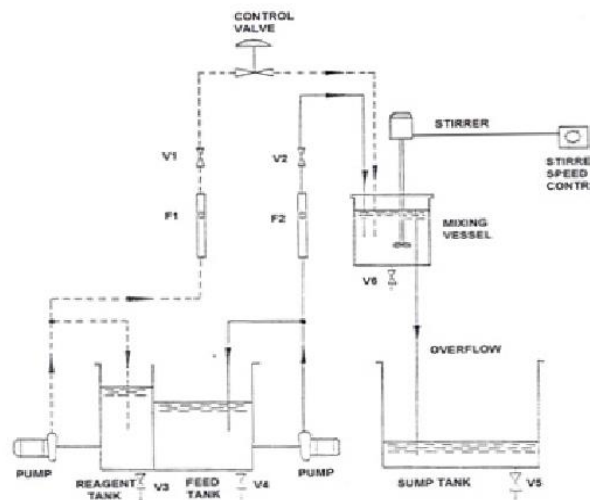

Figure 3. Process diagram of pH control

#### 3.1. Approximating pH process to FOPDT

For the step input of (0 to 30% opening of Ammonia flow rate valve), we note the following characteristics of its step response: to approximate into First Order Plus Delay Time (FOPTD) model,

- (i) The response attains 63.2% of its final response at time,  $t = \tau + \theta$ . (ii) The line drawn tangent to the response at maximum slope ( $t = \theta$ ) intersects the  $y/KM=1$  line at ( $t = \tau + \theta$ ). (iii) The step response is essentially complete at  $t=5\tau$ . In other words, the settling time is  $t_s=5\tau$ . The graphical the analysis to determine the FOPDT model is shown in the fig 4. Therefore the FOPDT model transfer function becomes

$$TF = \frac{4.67e^{-0.96s}}{0.4s + 1}$$

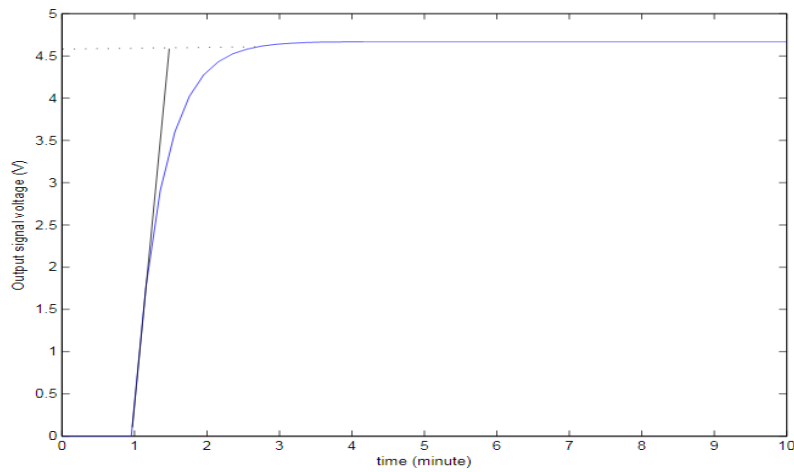

Figure 4. Graphical Analysis to Obtain the Model

**4. Methodology**

The Design of conventional PID controller and advanced controller are done using the Matlab tools. Figure 5 and 6 shows the diagram of PID and MPC tuning in the Matlab environment. The setpoints needed to be adjusted are 1.8, 1.9, 2.8 and 4.8. The PID controller gives good setpoint tracking when  $k_p = 0.10$ ,  $\tau_I = 0.17$  and  $\tau_D = 0.033$ . The MPC is tuned prediction horizon of 3, control horizon of 1 and control interval of 1.

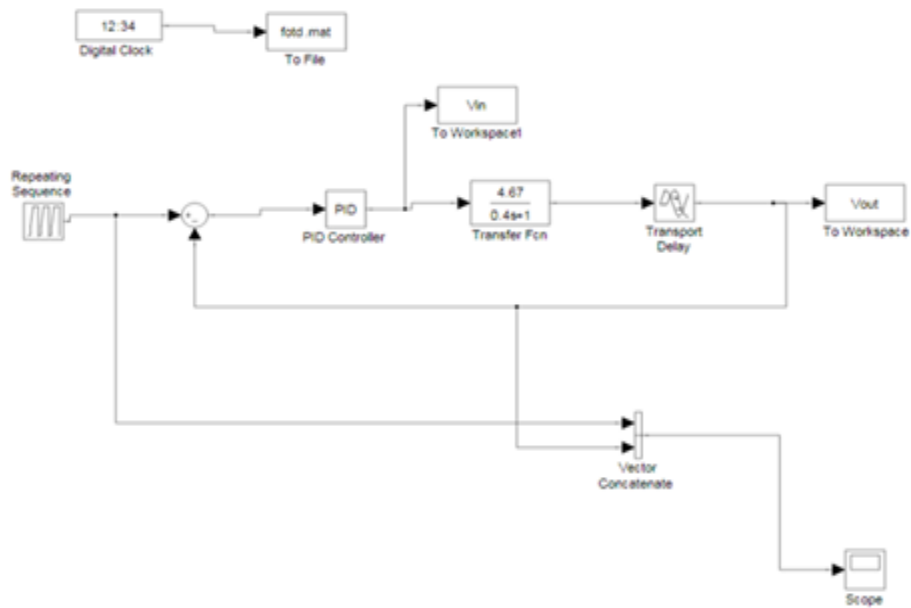

Figure 5. Simulink Diagram for PID Design

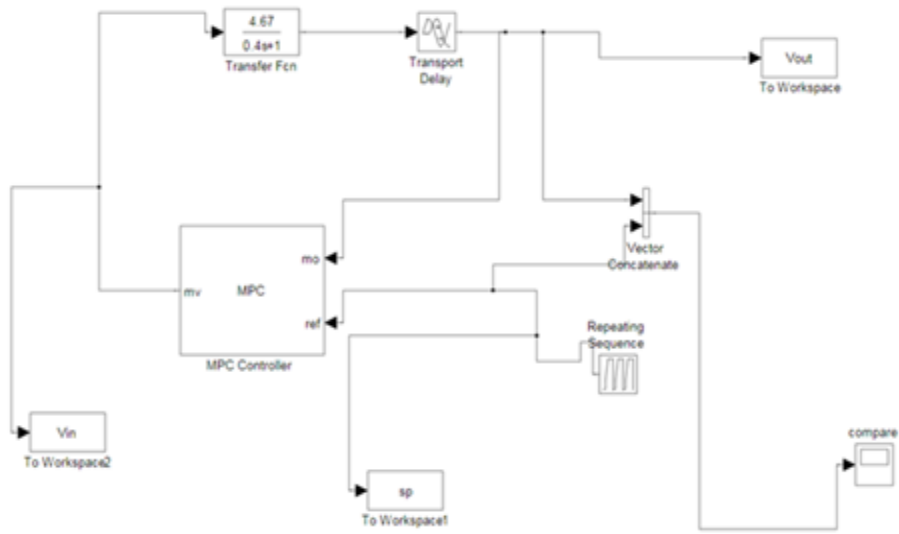

Figure 6. Simulink Diagram for MPC Design

**5. Results and Analysis**

The graph between time and the output signal has been obtained for PID, and MPC controller as shown in Figure 7. The comparison between these controllers has been done and the best controller has been obtained.

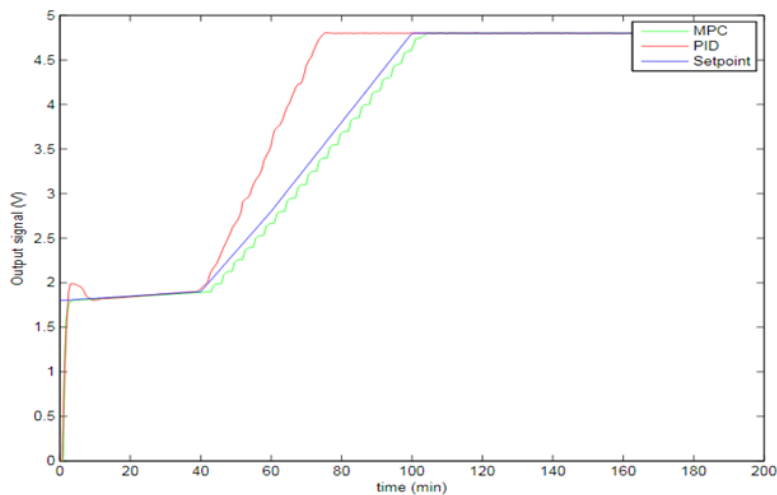

Figure 7. Output Response of PID and MPC Controller

We can observe from Figure 7 that how fast the MPC can reach the set-point. In the response of the PID we can easily the fulucations from the beginging itself and it is time consuming to reach the set point. Figure 8 shows the graph of input adjustment for both the controllers.

The output response of the MPC is faster than the response of the PID controller.

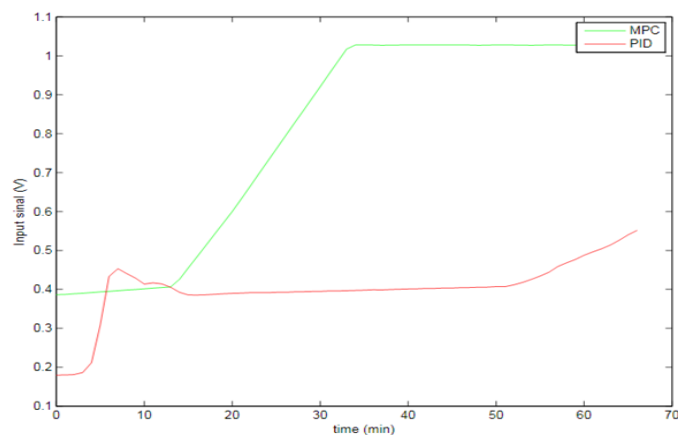

Figure 8. Input Adjustments by MPC and PID

## 6. Conclusion

The obtained transfer function is processed using classical and advanced controllers such as PID, and MPC. The values which are obtained from the tuning methods are simulated using MATLAB. It is seen from the response curve that MPC controller provides a better response with minimum time when compared with PID and IMC. So it is concluded that MPC controller is efficient for a pH process.

## References

- [1] Hans-Petter, Halvorsen. Model Predictive Control in labVIEW. *Dept. of Electrical Engineering Information Technology and Cybernetics*, Telemark University College. 2011.
- [2] Jonathan L. Process Automation Handbook - A guide to Theory and Practice.
- [3] Bemporad, A. Model Predictive Control: Basic concepts, *Controllo di Processo e Sistemi di Produzione*. 2009.
- [4] Camacho and Bordons. Model Predictive Control. Springer. 2004.
- [5] Rossiter J. Model based Predictive Control - A practical approach. CRC Press. 2003.
- [6] Mathworks.com. Model Predictive Control Toolbox. 2012.
- [7] J.Prakash, K.Srinivasan. Design of Non Linear PID Controller and Non Linear Model Predictive Controller for a Continuous stirred tank Reactor. *ISA Transactions*. 2009; 48: 273-282.
- [8] S.Abirami, H.Kala, P.B.Nevetha, B.Pradeepa, R.Kiruthiga, P.Sujithra. Performance Comparison Of Different Controllers For Flow Process. *International Journal of Computer Applications*. 2014; 90(19): 17-21.
- [9] E.F. Camacho, C. Bordons. Model Predictive Control in the Process. Springer-verlay. 1995.
- [10] Ljung. System Identification: Theory for the User. Printice-Hall: Engwood cliffs. 1987