

Assessment of the Potential to Increase Electricity Generation from Sugarcane Straw in Brazilian Sugarcane Cogeneration Plants

Marcelo Modesto^{a*}, Adriana C. Aoki^a, Andressa Lodi^a, Eduardo A. Pina^b

^aCentre of Engineering, Modelling and Social Sciences, Universidade Federal do ABC (CECS/UFABC), Santo André, Brazil

^bAragon Institute of Engineering Research (GITSE-I3A), Department of Mechanical Engineering, Universidad de Zaragoza, Zaragoza, Spain.

marcelo.modesto@ufabc.edu.br

The present work aims to evaluate the potential to increase electricity generation through the usage of sugarcane straw in sugarcane cogeneration plants. Currently the cogeneration plants use sugarcane bagasse as fuel in their systems based on Rankine Cycle presenting backpressure and condensing steam turbines. The utilisation of straw has become feasible after a change in the handling of sugarcane harvesting due to the ban on sugarcane burning, thus opening possibilities for its energetic usage. Three configurations of cogeneration plants were analysed: two traditional Rankine cycles, one with backpressure steam turbines and the other with condensing steam turbines, and a proposal of a cogeneration plant based on a BIGCC. Each configuration was assessed through exergetic cost analysis, aiming to evaluate the potential of electricity generation with the combined use of sugarcane bagasse and straw.

1. Introduction

Bioenergy has progressively been in the limelight over the last decades as a result of a growing concern about global warming, the depletion of fossil fuels and the increase in the world's energy demand. The world electricity generation from biomass and waste has doubled from 2003 to 2012, representing 8.15% of the total renewable electricity produced in 2012 (EIA, 2015). Regarding the alternative fuels for vehicle transportation, bioethanol is the most abundant (IEA, 2014). It can be produced from a variety of feedstock, such as sugarcane, corn, wheat, sugar beet, among others, but sugarcane is the one which presents the highest energy output/input ratio.

Sugarcane mills produce sugar and bioethanol from sugarcane. Bagasse is also produced as a by-product and is used as fuel in the cogeneration system, producing heat and electricity to supply the plant's energy demands.

Traditionally, the sugarcane industry in Brazil has been characterised by its low efficiency in producing energy from bagasse burning. However, since the early 2000's, the possibility of selling surplus electricity to the grid has stimulated improvements in the cogeneration system, so that recently, electricity has become the third main product alongside bioethanol and sugar (Walter & Ensinas, 2010).

The conventional sugarcane mills' cogeneration systems are steam-based cycles producing live steam from bagasse burning in boilers. The steam is expanded in backpressure steam turbines (BPST) or condensing steam turbines (CST), producing low pressure steam and electricity. The main advantages of CST over BPST are that all bagasse available can be consumed, thus generating more electricity, and that the cogeneration system is no longer dependent on the production process, which operates only during harvest season, thus being able to operate throughout the year.

Advanced cogeneration systems like the Biomass Integration Gasification Combined Cycle (BIGCC) can help sugarcane industry's cogeneration systems to boost their electricity generation. As demonstrated by Dias et al. (2011), BIGCC systems can produce over twice as much surplus electricity as the CST, provided a minimal production process steam demand is met.

Further possibilities for electricity generation improvement were opened after a federal law established the phasing out of sugarcane burning for 2018 in areas where mechanical harvesting is possible with the current technology. All the same, this is already a reality in the States of São Paulo and Minas Gerais, which account for the majority of Brazil's sugarcane production. Such change in the handling of cane harvesting has allowed the recovery of sugarcane's leaves and tops, also known as straw, thus increasing the amount of fuel for the cogeneration systems. However, as stated by Leal et al (2013), not all cane litter should be recovered from the ground, as it impacts positively the cultivation process. So still more knowledge is required in order to know how much should be left on the field in order to not compromise the soil and further harvests.

The aim of the present work is to evaluate the potential to increase electricity generation through the combined usage of sugarcane bagasse and straw in sugarcane cogeneration plants. Three configurations of cogeneration plants were analysed: two traditional Rankine Cycles, one presenting BPST and the other CST, and a proposal of a cogeneration plant based on a BIGCC cycle. Exergetic cost analyses for each configuration plant were carried out using the EES[®] (Engineering Equation Solver) software.

2. Methodology

Exergetic cost analyses were performed in order to assess each of the proposed cogeneration systems. This analysis is based on the application of mass, energy, exergy and exergy cost balances to all components of the plant. Thus, it is possible to determine energetic consumptions, irreversibility generation and the exergetic costs of the plant products.

Eqs.(1)-(3) respectively show mass, energy and exergy balances for a generic control volume assuming steady-state operation.

$$\sum \dot{m}_{in} - \sum \dot{m}_{out} = 0 \quad (1)$$

$$\dot{Q} - \dot{W} + \sum \dot{m}_{in}h_{in} - \sum \dot{m}_{out}h_{out} = 0 \quad (2)$$

$$\dot{Q}\left(1 - \frac{T}{T_0}\right) - \dot{W} + \sum \dot{m}_{in}e_{in} - \sum \dot{m}_{out}e_{out} = I \quad (3)$$

Eq.(4) was used to determine the specific exergies of water, steam, air, syngas and stack gases.

$$e = h_i - h_0 - T_0(s_i - s_0) + e_{ch}^0 \quad (4)$$

where h_i is the enthalpy of the flow at point "i", h_0 is the enthalpy of reference, s_i is the entropy at point "i", s_0 is the entropy of reference, and e_{ch}^0 is the chemical exergy, which was obtained from Szargut et al (1988). The pressure and temperature values of the reference state were considered to be 1 bar and 25 °C, respectively.

The exergy values of the sugarcane bagasse and the ethanol-water mixture were calculated following the methodology described by Sosa-Arnao and Nebra (1995) and Modesto, Nebra and Zemp (2005), respectively. The following items present the three configurations of cogeneration systems proposed and the methodology used to perform the exergetic cost analysis. All analyses were carried out using the EES[®] software.

2.1 Description of the cogeneration systems assessed

Rankine Cycle Cogeneration System (STCOND)

Since the beginning of the Proalcool Program in 1975, the main configuration of cogeneration system in sugarcane plants in Brazil is based on Rankine Cycle (Macedo, 2008). Using backpressure steam turbine, the cogeneration system supplies thermal, mechanical and electrical energy to the sugar and ethanol production process, the generation of electricity is limited by the process' thermal demand and, consequently, a bagasse surplus is available. In the past, selling electricity was not feasibly possible and the boilers of these cogeneration systems had low efficiency and high consumption of bagasse. After the Brazilian electrical crisis in 2001, the selling of electricity to the grid became a reality and systems based on condensing steam turbines began to be used, so that all bagasse available was used to generate electricity.

Figure 1 shows the basic configuration of Rankine Cycle used in cogeneration systems with condensing steam turbines employed in Brazil. The configuration presents a boiler, a condensing steam turbine, a deaerator, a condenser and pumps. The cogeneration system provides steam (2.5 and 6 bar of pressure) and electricity to supply the anhydrous ethanol production process. The process receives cane (flow 25) and produces ethanol (flow 27), vinasse (flow 28) and bagasse (flow 26). Besides bagasse, sugarcane straw is also used as fuel in the boiler (flow 29).

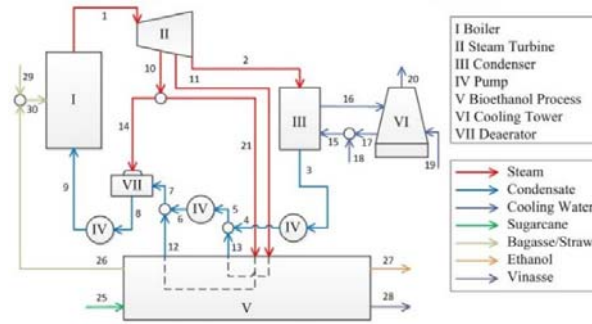

Figure 1: Sketch of the cogeneration system based on Rankine Cycle

Biomass Integrated Gasification Combined Cycle -BIGCC Cogeneration

The alternative of employing synthesis gas, or syngas, in gas turbines have been studied by several works: Palmer et al (1993), Walter and Llagostera (1995; 2003), Kapat et al (1997), Korobitsyn et al (1999), Nascimento et al (2001), Ferreira (2003), and Dias et al (2011). Some works consider the exclusive use of syngas, others the combined use of syngas and natural gas. In this work, the gas turbine consumes only syngas produced from the gasification of a mixture of sugarcane bagasse and straw.

Comparing a traditional gas turbine designed to operate with natural gas, the main difference occurs in relation to the fuel. The syngas has a Lower Heating Value (LHV) lower than the natural gas's, approximately 5,178 kJ/kg (value obtained through a gasification model available in Pellegrini and Oliveira Jr. (2005)), while the natural gas's reaches 47,500 kJ/kg.

In our proposal, a gas turbine using only syngas is simulated using the Gate Cycle® Software, developed by GePower. Some suggestions to this gas turbine operating with syngas is presented by Palmer et al (1993). The main parameters analysed were the pressure ratio and the exit temperature of the combustion chamber. The syngas from the gasifier is compressed in a compressor and enters a combustion chamber along with an air flow, both at the same pressure, where they react. The produced gases expand in a power turbine producing mechanical energy and electricity in an electrical generator. A performance comparison of a gas turbine burning syngas and natural gas was carried out in a previous work by Modesto et al (2007).

It is important to mention that the exclusive use of biomass gas in the gas turbine requires a catalytic combustion chamber designed specifically to operate with low LHV fuels. Proposals of catalytic combustion chambers can be found in Witton et. al (2003) and Forzatti (2003).

Figure 2 shows a proposal to use a BIGCC system to maximise electricity generation. The BIGCC system is composed of an atmospheric gasifier, a dryer, a gas turbine set, a Heat Recovery Steam Generator (HRSG) and Backpressure-Condensing Steam Turbine that provides steam to the process. The bagasse produced by the process (flow 26) is dried in the dryer, using the stack gases from the HRSG, and then mixed with the sugarcane straw (flow 30). The mixture is sent to an atmospheric gasifier where the syngas production takes place. The syngas produced (flow 33) is compressed in a syngas compressor and then enters the combustion chamber (flow 34), reacting with the compressed air (flow 2) and producing stack gases (flow 3). The stack gases enter the HRSG, where steam at 480 °C and 80 bar is produced to supply the bioethanol production process steam demand, and then sent to the bagasse dryer. The gasification process was modelled by Brito et al (2015). The elementary analysis of bagasse showed 44.6% of Carbon, 5.8% of Hydrogen, 44.5% of Oxygen, 0.6% of Nitrogen, 0.1% of Sulfur, 0.02.% of Chlorine and 4.38% of Ash. The elementary composition of straw showed 46.2% of Carbon, 6.2% of Hydrogen, 43% of Oxygen, 0.5% of Nitrogen, 0.1% of Sulfur, 0.1% of Chlorine, 3.9% of Ash (Basu, 2010).

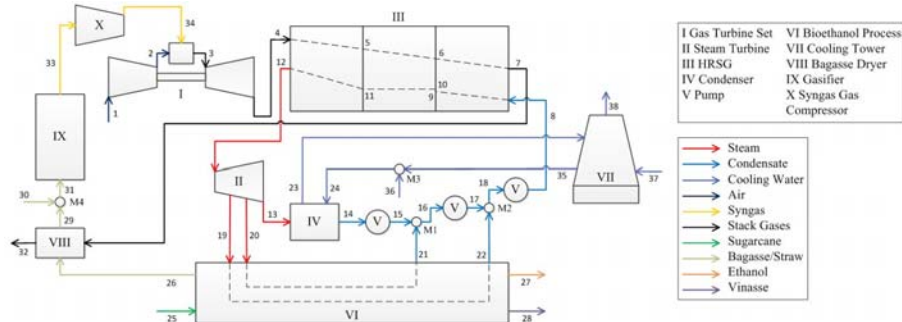

Figure 2 Sketch to cogeneration system based in BIGCC Cycle.

Table 1 presents the main parameters considered in the simulations, where tc means ton of sugarcane.

Table 1: Main parameters used in the simulations

Parameter	STCOND	BIGCC
Bagasse Fibre (%)		13
Direct Drive Power (kWh/tc)		20
Electrical Energy Consumption (kWh/tc)		15
Ethanol Production (l/tc)		85
Crushing Cane (t/h)		493
Isentropic Efficiency – Steam Turbine		0.88
Electrical Generator Efficiency		0.98
Process Steam Consumption – 2.5 bar (kg/s)		22.94
Process Steam Consumption – 6 bar (kg/s)		8.29
Isentropic Efficiency – Pumps	0.85	0.85
Isentropic Efficiency – Gas Turbine	-	0.90
Isentropic Efficiency – Compressors	-	0.88

2.2 Exergetic cost analysis

The exergetic cost analysis was carried out through the Theory of Exergetic Cost methodology, proposed by Lozano and Valero (1993), which allows the unit exergetic cost of each flow to be determined. This methodology has been applied by Sanchez and Nebra (2002) to assess the influence of sugarcane bagasse prices on the costs of steam and electricity production; in turn, Fernandez Parra (2003) employed it to determine the exergetic cost of sugar in the production process; Dias et al (2011) evaluated the steam and electricity unit exergetic costs of two traditional Rankine Cycles and a BIGCC.

Eq.(5) shows the exergy cost balance for a generic control volume.

$$\sum k_{in}E_{in} - \sum k_{out}E_{out} = 0 \quad (5)$$

where k is the non-dimensional parameter unit exergetic cost and E is the total exergy flow.

Applying Eq.(5) to all plant's components forms a linear equation set where the number of variables is greater than the number of equations. Therefore, it is necessary to add some additional equations following the considerations proposed by Lozano and Valero (1993), which have been reported in a simple way by Cerqueira and Nebra (1999). Table 2 presents these additional equations for both the STCOND and the BIGCC configurations.

To the unit exergetic costs of the flows entering the plant (sugarcane, sugarcane straw, water and air) a unitary value was assigned (Eqs.(6) and (13)). To the loss of water in the cooling tower and the stack gasses that leave the dryer in the BIGCC configuration, a zero value was attributed (Eqs.(7) and (14)).

All the irreversibility generated by the steam and gas turbines must be carried out by its main product, the mechanical work (Eqs.(8), (15) and (16)). Similarly, all the ethanol production process's irreversibility must be carried out by its main product, the ethanol. Therefore, two considerations were made: (i) the exergy-based costs of the steam entering and leaving the process are the same (Eqs.(9) and (17)), and (ii) the exergy-based costs of both bagasse and vinasse are equal to that of the sugarcane (Eqs.(11) and (19)).

In the splitters, where no generation of irreversibility takes place, the unit exergetic cost of the flows entering and leaving the equipment are equal (Eq.(10)). For the BIGCC system, the unit exergetic cost of the stack gasses was considered the same throughout the HRSG (Eq.(18)). Therefore, all the irreversibility generated in that equipment will be carried out by the steam produced. Finally, it has been attributed the same value to the unit exergetic costs of the cooling water that enters and leaves the condenser (Eqs. (12) and (20)).

Table 2: Cost allocation for Rankine and BIGCC configurations

Rankine	BIGCC
$k_{18} = k_{19} = k_{25} = k_{29} = 1$	$k_1 = k_{24} = k_{25} = k_{30} = 1$
$k_{20} = 0$	$k_{32} = k_{38} = 0$
$k_1 = k_2 = k_{10} = k_{11}$	$k_4 = k_3$
$k_{12} = k_{21}$ and $k_{13} = k_{11}$	$k_{12} = k_{13} = k_{19} = k_{20}$
$k_{10} = k_{14} = k_{21}$	$k_{21} = k_{20}$ and $k_{22} = k_{19}$
$k_{26} = k_{28} = k_{25}$	$k_4 = k_5 = k_6 = k_7$
$k_{15} = k_{16}$	$k_{26} = k_{28} = k_{25}$
	$k_{23} = k_{24}$

3. Results

The traditional cogeneration system in Brazil is based on Rankine Cycle with backpressure-condensing steam turbines. Thus, it is possible to maximise the generation of electricity from all available biomass. In this study, two configurations of Rankine Cycle cogeneration systems were assessed: (i) boiler operating only on sugarcane bagasse, and (ii) boiler operating on a mixture of sugarcane bagasse and straw. Table 3 shows the main results obtained from the simulations for each configuration: electricity surplus and exergetic based-cost of steam, electricity and ethanol. In the first case, the electricity surplus available for sale is 91.67 kWh/tc, the electricity and ethanol exergetic based-costs are 4.094 and 1.512, respectively, values similar to the ones reported by Dias et al (2011). The availability of sugarcane straw is of 15% per ton of sugarcane. The combined use of sugarcane bagasse and straw allows an increase in the availability of primary energy to support the thermal and electrical demands of the ethanol production process. With sugarcane straw combined with sugarcane bagasse, the electricity surplus reaches 129.3 kWh/tc (+41%), the unit exergetic costs of electricity 3.945 (-3.7%) and ethanol 1.512 (0.8%). That is, the use of sugarcane straw combined with sugarcane bagasse allows a significant increase in the electricity surplus without an increase in the exergetic based-cost of the main products of the plant. The efficiency of the use of the energetic resource remains the same, however, with a significant increase of electricity generation.

The BIGCC cogeneration system uses a biomass gasifier (in this case, a mixture of 85% of bagasse and 15% of straw) to produce syngas that is consumed in a combined cycle to supply the thermal and electrical demand of ethanol production process. The adoption of BIGCC leads to an electricity surplus of 149.2 kWh/tc (+62.7% than traditional case) and exergy cost-based of electricity of 3.116 (-23%) and ethanol of 1.449 (-4.2%). The BIGCC configuration achieved a better performance than the Rankine cogeneration system. The electricity surplus and the unit exergetic costs of electricity and ethanol are better than the Rankine cycle's, indicating that it is a very attractive option to improve the potential to generate electricity from sugarcane.

Table 3: Main simulation results

Cogeneration System	Electricity Surplus (kWh/tc)	Unit exergetic cost		
		Steam	Electricity	Ethanol
Rankine without straw	91.67	3.578	4.094	1.512
Rankine with straw	129.30	3.440	3.945	1.500
BIGCC	149.20	3.594	3.116	1.449

4. Conclusions

This study presented the main results of the simulations of three configurations of cogeneration systems of ethanol production plants that use sugarcane bagasse and straw as fuel to supply thermal and electrical demand to the process. The configurations based on the Rankine Cycle using sugarcane straw and bagasse as a fuel represented an interesting possibility, as assessed by the exergy-based cost, to increase electricity surplus without decreasing the efficiency of the use of energy in the production of electricity and ethanol. However, the BIGCC cogeneration system presented a higher possibility to increase the electricity surplus and efficiency in the use of energy, as shown by the unit exergetic costs of electricity and ethanol. Moreover, it is important to highlight that the investment cost of a BIGCC system is greater than a Rankine's, especially in light of lower attractiveness of gasification technology in biomass use, as well as of the operation of specific gas turbines with syngas. Nevertheless, considering the uncertainty in the Brazilian electricity supply in next years, such potential should not be despised. According to UNICA (2015) the estimate of sugarcane crop in 2014/2015 is 650 million tons of sugarcane, leading to a potential of electricity generation of 37 GWh.

Reference

- Basu, P. (2010). Biomass gasification and pyrolysis. Burlington, MA: Academic Press.
- Brito, A. L. ; Gallego, A. G. ; Modesto, M., Assessment Of Gasification Models For A Bigcc Cycle Using Sugarcane Bagasse And Straw, In: 28nd International Conference on Efficiency, Cost, Optimization - ECOS 2015, 2015, Pau - França. Proceedings of 28nd International Conference on Efficiency, Cost, Optimization - ECOS 2015, 2015. v. 1. p. 1-10
- Carqueira, S. and Nebra, S. (1999). Cost attribution methodologies in cogeneration systems. Energy Conversion and Management, 40(15-16), pp.1587-1597.
- Dias, M., Modesto, M., Ensinas, A., Nebra, S., Filho, R. and Rossell, C. (2011). Improving bioethanol production from sugarcane: evaluation of distillation, thermal integration and cogeneration systems. Energy, 36(6), pp.3691-3703.

- EIA (Independent Statistics & Analysis), (2015). U.S. Energy Information Administration (EIA). [online] International Energy Statistics. Available at: <http://www.eia.gov/> [Accessed 13 Nov. 2015].
- Fernandez Parra, M. (2003). Exergoeconomic methodology in sugar process. Ph.D Thesis. School of Mechanical Engineering, State University of Campinas [in Portuguese].
- Ferreira, S., Nascimento, M. and Pilidis, P. (2003). The Use of Biomass Fuels in Gas Turbine Combined Cycles: Gasification vs Externally Fired Cycle. In: III World Climate & Energy Event. Rio de Janeiro, Brazil: vol. 1, pp.1-8.
- Forzatti, P. (2003). Status and perspectives of catalytic combustion for gas turbines. *Catalysis Today*, 83(1-4), pp.3-18.
- IEA (International Energy Agency), (2014). Key World Energy Statistics. [online] Available at: <http://www.iea.org/publications/freepublications/publication/keyworld2014.pdf> [Accessed 13 Nov. 2015].
- Kapat, J., Agrawal, A. and Yang, T. (1997). Air Extraction in a Gas Turbine for Integrated Gasification Combined Cycle (IGCC): Experiments and Analysis. *J. Eng. Gas Turbines Power*, 119(1), p.20.
- Korobitsyn, M., Jellema, P. and Hirs, G. (1999). Possibilities for gas turbine and waste incinerator integration. *Energy*, 24(9), pp.783-793.
- Leal, M., Galdos, M., Scarpore, F., Seabra, J., Walter, A. and Oliveira, C. (2013). Sugarcane straw availability, quality, recovery and energy use: A literature review. *Biomass and Bioenergy*, 53, pp.11-19.
- Lozano, M. and Valero, A. (1993). Theory of the exergetic cost. *Energy*, 18(9), pp.939-960.
- Macedo, I., Seabra, J. and Silva, J. (2008). Greenhouse gases emissions in the production and use of ethanol from sugarcane in Brazil: The 2005/2006 averages and a prediction for 2020. *Biomass and Bioenergy*, 32(7), pp.582-595.
- Modesto, M., Nascimento, M. and Nebra, S. (2007). Proposals for BIGCC Cycle Utilization in an Ethanol Production Plant from Sugarcane. In: ECOS 2007 – The 20th International Conference on Efficiency, Costs, Optimization, Simulation and Environmental Impact of Energy Systems. Padova, Italy, pp.761-768.
- Modesto, M., Nebra, S. and Zemp, R. (2005). A proposal to calculate the exergy of non-ideal mixtures ethanol-water using properties of excess. In: Proceedings of the 14th European Biomass Conference & Exhibition, Biomass for Energy, Industry and Climate Protection. Paris, France.
- Nascimento, M., Ferreira, S. and Pilidis, P. (2001). A Comparison of Different Gas Turbine Concepts Using Biomass Fuel. The American Society of Mechanical Engineers, New Orleans.
- Palmer, C., Erbes, M. and Pechtl, P. (1993). Gate Cycle performance analysis of the LM2500 gas turbine utilizing low heating values. In: Proceedings of IGTI ASME Cogen-Turbo.
- Pellegrini, L. and Oliveira Jr., S. (2005). Exergy Analysis of Sugarcane Bagasse Gasification. In: Proceedings of ECOS 2005 - The 18th International Conference on Efficiency, Costs, Optimization, Simulation and Environmental Impact of Energy Systems. Trondheim, Norway, pp.393-400.
- Sanchez, M. and Nebra, S. (2002). Thermo-economic analysis of a cogeneration system of a sugar mill plant. In: Proceedings of ECOS 2002 – The 15th international conference on efficiency, costs, optimization, simulation and environmental impact of energy systems. Berlin, Germany.
- Sosa-Arnan, J. and Nebra, S. (1995). Exergy of sugar cane bagasse. In: Proceedings of the 14th European Biomass Conference & Exhibition, Biomass for Energy, Industry and Climate Protection. Paris, France.
- Szargut, J., Morris, D. and Steward, F. (1988). Exergy analysis of thermal, chemical, and metallurgical processes. New York: Hemisphere.
- UNICA, (2015). Relatório Final Safra 2014/2015 - Região Centro-Sul do Brasil. [online] Unica.com.br. Available at: <http://www.unica.com.br/historico-de-producao-e-moagem.php> [Accessed 11 Dec. 2015].
- Walter, A. and Ensinas, A. (2010). Combined production of second-generation biofuels and electricity from sugarcane residues. *Energy*, 35(2), pp.874-879.
- Walter, A. and Llagostera, J. (1995). Exergetic and Thermo-economic Analysis of Biomass Integrated Gasifier/Gas Turbine Power Cycles. In: Proceeding of the ASME COGEN-Turbo Power Conference. Vienna, Austria.
- Walter, A. and Llagostera, J. (2003). Off-Design Operation of Cofired Combined Cycles. In: Proceedings ECOS 2003 – The 16th International Conference on Efficiency, Costs, Optimization, Simulation and Environmental Impact of Energy Systems. Copenhagen, Denmark, pp.1443-1450.
- Witton, J., Noordally, E. and Przybylski, J. (2003). Clean catalytic combustion of low heat value fuels from gasification processes. *Chemical Engineering Journal*, 91(2-3), pp.115-121.