



# THE UNIVERSITY *of* EDINBURGH

## Edinburgh Research Explorer

### **Mobile organic compounds in biochar - a potential source of contamination - phytotoxic effects on cress seed (*Lepidium sativum*) germination**

**Citation for published version:**

Buss, W & Masek, O 2014, 'Mobile organic compounds in biochar - a potential source of contamination - phytotoxic effects on cress seed (*Lepidium sativum*) germination' *Journal of Environmental Management*, vol. 137, pp. 111-119. DOI: 10.1016/j.jenvman.2014.01.045

**Digital Object Identifier (DOI):**

[10.1016/j.jenvman.2014.01.045](https://doi.org/10.1016/j.jenvman.2014.01.045)

**Link:**

[Link to publication record in Edinburgh Research Explorer](#)

**Document Version:**

Early version, also known as pre-print

**Published In:**

*Journal of Environmental Management*

**General rights**

Copyright for the publications made accessible via the Edinburgh Research Explorer is retained by the author(s) and / or other copyright owners and it is a condition of accessing these publications that users recognise and abide by the legal requirements associated with these rights.

**Take down policy**

The University of Edinburgh has made every reasonable effort to ensure that Edinburgh Research Explorer content complies with UK legislation. If you believe that the public display of this file breaches copyright please contact [openaccess@ed.ac.uk](mailto:openaccess@ed.ac.uk) providing details, and we will remove access to the work immediately and investigate your claim.



1 Mobile organic compounds in biochar – a potential source of  
2 contamination – phytotoxic effects on cress seed (*Lepidium*  
3 *sativum*) germination

4 Wolfram Buss<sup>a</sup>, Ondřej Mašek<sup>a</sup>

5 <sup>a</sup>UK Biochar Research Centre, School of GeoSciences, University of Edinburgh, Crew Building, King's Buildings,  
6 Edinburgh, EH9 3JN, UK

7 Correspondence: Ondřej Mašek, tel. 0131 6505095, fax +44 131 662 0478, e-mail: [ondrej.masek@ed.ac.uk](mailto:ondrej.masek@ed.ac.uk)

8 **Abstract**

9 Biochar can be contaminated during pyrolysis by re-condensation of pyrolysis  
10 vapours. In this study two biochar samples contaminated by a high degree of re-  
11 condensation which resulted in high volatile organic compound (high-VOC) content,  
12 were investigated and compared to a biochar with low volatile organic compound  
13 (low-VOC) content. All biochar samples were produced from the same feedstock  
14 (softwood pellets) under the same conditions (550°C, 20 min mean residence time).  
15 In experiments where only gaseous compounds could access germinating cress  
16 seeds, application amounts ranging from 1-30 g of high-VOC biochar led to total  
17 inhibition of cress seed (*Lepidium sativum*) germination, while exposure to less than  
18 1 g resulted in only partial reduction. Furthermore, leachates from biochar/sand  
19 mixtures (1, 2, 5 wt.% of biochar) induced heavy toxicity to cress seed germination  
20 and showed that percolating water dissolved toxic compounds easily. Low-VOC  
21 biochar didn't exhibit any toxic effects in either germination test. Toxicity mitigation  
22 via blending of a high-VOC biochar with a low-VOC biochar increased germination  
23 rate significantly. These results indicate re-condensation during pyrolysis can result  
24 in biochar containing highly mobile, phytotoxic compounds. However, it remains  
25 unclear, which specific compounds are responsible for this toxicity and how  
26 significant re-condensation in different pyrolysis units might be.

27 **Keywords**

28 contaminant; germination; volatile organic compound; re-condensation; pyrolysis;  
29 biochar

30 **Abbreviations**

31 GC biochar = gas contaminated biochar  
32 LC biochar = liquid contaminated biochar  
33 NC biochar = non-contaminated biochar  
34 VM = volatile matter  
35 VOC = volatile organic compound

## 1 Introduction

2 Biochar is defined as charred organic matter which is incorporated into soil for the  
3 purpose to ameliorate soils (Schimmelpfennig and Glaser, 2012). It can be used as  
4 an amendment to improve soil properties and at the same time leads to long-term  
5 carbon sequestration in the ground (Lehmann and Joseph, 2009).  
6 For future large-scale application of biochar, it is important to ensure that biochar will  
7 neither show toxic effects nor otherwise pose a short or long-term threat to soil and  
8 the environment, e.g. in form of bound contaminants. Most research on  
9 contaminants in biochar focus on the latter, on bound and rather non-bioavailable  
10 heavy metals and polycyclic aromatic hydrocarbons (PAHs) (Fabbri et al., 2012;  
11 Freddo et al., 2012; Hale et al., 2012; Hilber et al., 2012; Oleszczuk et al., 2013;  
12 Rogovska et al., 2012; Singh et al., 2010). Nevertheless, volatile and/or easily  
13 leachable organic compounds exist within biochar and can cause positive (Elad et  
14 al., 2011) as well as negative effects (Smith et al., 2013).  
15 Few studies have been published in which the composition and impact of residual  
16 tars and other organic compounds from pyrolysis on direct and acute toxicity has  
17 been assessed (Smith et al., 2013; Spokas et al., 2011; Yang et al., 2013). Pyrolysis  
18 liquids primarily consist of low-molecular weight degradation products of cellulose,  
19 hemicellulose and lignin (Cordella et al., 2012). The compound classes that are  
20 covered are mainly organic acids, aldehydes, furans, ketones, alcohols and phenols,  
21 however, PAHs can be found as well (Cordella et al., 2012; Sánchez et al., 2009;  
22 Sfetsas et al., 2011). During pyrolysis, re-condensation of pyrolysis liquids and gases  
23 occurs depending on production conditions and pyrolysis technology (Spokas et al.,  
24 2011). As contamination of char with volatile organic compounds is not an issue in  
25 systems focused on electricity/biofuel production, this aspect has not been a focus of  
26 extensive research. It is, yet, a critical consideration in designing units for production  
27 of biochar. Furthermore, due to the high variability of the re-condensation process  
28 and the influence of post-handling on concentrations and composition of volatile  
29 organic compounds, it is difficult to draw conclusions about their impact on plant  
30 growth and the ecosystem. Thus, to be able to determine the potential impact of  
31 biochar-derived mobile organic compounds on seed germination, this study  
32 investigated biochar samples containing high concentrations of VOCs as a result of  
33 irregularities during production.  
34

35 Several studies have looked at different methods for reducing the toxicity of  
36 biochar/hydrochar (char from hydrothermal carbonization) vapours (Bargmann et al.,  
37 2013; Busch et al., 2012). Busch et al. (2012) demonstrated significant improvement  
38 of germination performance when exposed to hydrochar vapours after the hydrochar  
39 had been kept in closed storage and were dried. Furthermore, washing of hydrochar  
40 and biochar with water or an organic solvent has been successfully tested to reduce  
41 phytotoxicity of solids or extracts (Bargmann et al., 2013; Bernardo et al., 2010;  
42 Rogovska et al., 2012).

1 Another potential method for VOC toxicity mitigation is to use low-VOC biochar to  
2 sorb contaminants from high-VOC biochar. Biochar has proven to sorb organic and  
3 inorganic compounds from soil (Buss et al., 2012; Gomez-Eyles et al., 2011; Huang  
4 and Chen, 2010; Ogbonnaya and Semple, 2013). Furthermore, Rogovska et al.  
5 (2012) showed that biochar can sorb allelochemicals from corn residues in solution  
6 and reduces their toxicity on seedling growth. As shown for activated carbon, which  
7 is used in practice for effluent gas cleaning (Rodríguez-Mirasol et al., 2005), biochar  
8 might be able to sorb volatile organic compounds, thus, reduce toxicity of VOCs.

9 Therefore, in this study, biochar contaminated by pyrolysis liquids and pyrolysis  
10 vapours during production were investigated for toxicity. The study focussed on the  
11 effect these biochars have on germination of cress seeds, where germination results  
12 were compared with germination rates of seeds treated with a low-VOC biochar  
13 produced under the same conditions. Furthermore, storage and blending of high-  
14 VOC and low-VOC biochar were tested as methods to reduce the toxicity of the  
15 biochars contaminated with VOCs, because these methods are easy to perform,  
16 cheap and reasonable to be used in practical applications. The aim of the study is to  
17 assess the extent of phytotoxicity of VOCs, to determine whether high-VOC biochar  
18 can be safely used in practice and whether toxicity can be reduced/mitigated.

19

## 20 **2 Materials and Methods**

### 21 **2.1 Biochars**

22 All biochar samples were produced from the same feedstock (softwood pellets)  
23 pyrolysed at the same nominal highest treatment temperature (550°C), with the  
24 same mean residence time (20 min) and in the same pyrolysis unit (rotary kiln;  
25 Figure 1) (Table 1). However, due to production difficulties during the set-up of the  
26 unit two biochar batches were contaminated, in different ways, resulting in biochars  
27 with high-VOC content. The high VOC content could be readily detected due to the  
28 strong odour of the batches. To investigate the properties of these contaminated  
29 biochars, the two high-VOC biochars, herein described as liquid contaminated (LC)  
30 biochar and gas contaminated (GC) biochar were assessed against a low VOC, non-  
31 contaminated (NC) biochar.

32 LC biochar was contaminated by liquids which condensed on the wall of the  
33 discharge chamber, where biochar is separated from pyrolysis gas, as the  
34 temperature of the wall was lower than usual (Figure 1).

35 During a separate pyrolysis run, under the same experimental conditions, fouling had  
36 blocked a pipe that leads gases from the discharge chamber to the afterburner. As a  
37 result, pyrolysis gases and vapours filled the discharge chamber and cooling screw

1 (Figure 1), and were therefore absorbed by the biochar, resulting in contamination of  
2 the GC biochar.

3 NC biochar was obtained following a successful pyrolysis run with no observed  
4 blockages or re-condensation of volatiles, resulting in odourless, comparably  
5 uncontaminated biochar.

6 For this pyrolysis facility, the degree of re-condensation on these biochars can be  
7 considered as high and unusual; however, it is important to investigate these  
8 materials to become aware of potential effects of re-condensed products, even if at  
9 lower concentrations, as highly diverse biochars from numerous and varied  
10 pyrolysis units are used for plant studies.

11

## 12 **2.2 Characterisation of biochars**

13 Several analyses were performed on LC, GC and NC biochar to identify their  
14 chemical characteristics. For proximate analysis, biochar samples were crushed  
15 before thermo-gravimetric analysis using a Mettler-Toledo TGA/DSC1. The method  
16 used was as follows: moisture was evaporated by heating the sample up to 110°C  
17 using a heating rate of 25°C/min and held at 110°C for 10 min. Volatiles were driven  
18 off using a heating rate of 25°C/min up to 900°C and held at this temperature for 10  
19 min. Both steps were performed at a nitrogen gas rate of 50 mL/min. The final step  
20 involved introduction of air at 900°C for 20 min to oxidize fixed carbon and determine  
21 ash content. A blank sample was run prior to the experiment to account for weight  
22 changes in the crucible.

23 The pH of the biochar samples was measured according to Rajkovich et al. (2012),  
24 the standard test method outlined in the IBI guidelines 2012 (International Biochar  
25 Initiative, 2013). 20 mL of distilled water was added to 1 g of ground biochar and  
26 shaken for 1.5 h. A pH meter (Mettler Toledo FE 30) was used for pH determination  
27 of the extracts.

28

## 29 **2.3 Germination tests**

30 Both germination tests, i.e., 'volatiles only' and 'all exposure routes' were based on  
31 the same principle: a seven day germination test with 30 cress seeds (*Lepidium*  
32 *sativum*) on filter paper in plastic jars at 20-25°C and 24 h light in the lab. The  
33 continuous light regime was chosen according to Müller et al. (2006). Cling foil was  
34 wrapped around the top of the jars and punctured several times to allow limited gas  
35 exchange. In this way, the system was neither sealed, nor was free gas exchange  
36 allowed; rather slow diffusion of gases was permitted. All tests were performed in  
37 three replicates unless stated otherwise. The containers with seeds were placed on  
38 a shelf in a randomized design to provide equal growth conditions. Germination rate,

1 root and shoot length were determined. The pH of the filter paper on which the seeds  
2 were placed was also measured using universal indicator paper.

### 3 **2.3.1 'Volatiles only' germination test**

4 The test design was adapted from Busch et al. (2012) with the aim of assessing the  
5 phytotoxicity of organic compounds that vaporize readily at room temperature  
6 (volatile organic compounds, VOCs). As outlined in Figure 2, different amounts (30,  
7 10, 5, 2, 1, 0.5, 0.25 g) of crushed biochar were placed in an aluminium container  
8 (55 mm height, 80 mm diameter) with a stainless metal mesh on top. The mesh  
9 supported a filter paper (Whatman No. 1, 70 mm) on which 30 cress seeds  
10 (*Lepidium sativum*) were spread and to which two folded filter papers (Whatman No.  
11 1, 110 mm) supplied distilled water. This set up was situated within a 1 L plastic  
12 storage jar, so that only volatiles released from biochar could access and affect the  
13 seeds.

### 14 **2.3.2 'All exposure routes' germination test**

15 The 'all exposure routes' test is based on the setup used by Bargmann et al. (2013)  
16 to study the effect of VOCs and direct contact of seeds with biochar, but adds a  
17 biochar leachate fraction (Figure 3). This way, the test is designed to assess the  
18 effect of contaminants in three different forms (gaseous, dissolved and attached to  
19 biochar). Three different seed contact systems were investigated:

- 20 1) Volatiles only
- 21 2) Volatiles and leached (dissolved) compounds (in water) and
- 22 3) Volatiles, leached (dissolved) compounds and direct contact with biochar

23 Crushed biochar was mixed with sand (50-70  $\mu\text{m}$ ) in ratios of 1, 2 and 5 % (w/w) and  
24 50 g of this mixture was placed in aluminium container (25 mm height, 70 mm  
25 diameter) with holes in the bottom. 35 mL of distilled water was poured over the  
26 mixture and percolated through the sample to dissolve mobile compounds. The  
27 design allowed the leachate to flow back towards the biochar/sand mixture through a  
28 folded filter paper. Two small lids and two pieces of filter paper supplied clean water  
29 to a filter paper on an elevated area on top of the biochar/sand mixture. 30 seeds  
30 were spread on the top filter paper, on the biochar/sand mixture and on a filter paper  
31 at the bottom on the metal mesh (all Whatman No. 1, 70 mm).

32

## 33 **2.4 Biochar post-treatments**

34 Different biochar post treatments were performed to assess their suitability for  
35 reducing the release of volatiles from contaminated biochars and these treatments  
36 subsequent assessed in 'volatile only' germination tests.

37 NC, GC and LC biochar samples were stored at ambient temperature in aluminium  
38 trays for 4 weeks, covered by a paper tissue to avoid contamination from particles  
39 from the air. To prevent an initial peak release of volatiles, stored biochar samples  
40 were crushed after storage to release any desorbed, gaseous VOCs trapped within

1 the biochar structure. The biochars were assessed in different amounts (0.25, 0.5, 1,  
2 2, 5, 10, 30 g) in a 'volatile only' germination test in three replicates as described  
3 above.

4 In addition to storage post treatment, blending of biochar samples was also  
5 investigated. Low-VOC biochar was blended with high-VOC biochar (NC biochar  
6 with LC biochar) to test if low-VOC biochar was able to mitigate the release of VOC  
7 associated with the high-VOC biochar via sorption. 10 g samples of biochar  
8 containing 10 and 20% (w/w) high-VOC biochar content were tested using a 'volatile  
9 only' germination test in five replicates.

## 10 **2.5 Data analysis**

11 Results were evaluated statistically using Analysis of Variance (ANOVA) performed  
12 with SigmaPlot 12 (Systat Software Inc., Chicago, IL) followed by Student-Newman-  
13 Keuls post hoc tests. Occasionally, t-tests were used to determine differences  
14 between the treatments. Different letters in the figures indicate significant differences  
15 between the treatments ( $p < 0.05$ ). P-values in the legends indicate error probability  
16 of an effect of the treatments on a respective parameter.

## 3 Results and discussion

### 3.1 Characterisation of biochars

Results for proximate analysis of LC, GC and NC biochar can be found in Table 1. Proximate analysis showed NC biochar had a volatile content of 14.7% and a fixed carbon content of 83.6%. The NC biochar contained low volatile matter (VM) levels compared to values found in literature for VM content of pine biochar (pyrolysis temperature 450 - 600°C; VM 17 - 37%) (Crombie et al., 2013; Mukome et al., 2013; Ronsse et al., 2013).

The thermo-gravimetric analysis (TGA) revealed weight loss in the liquid contaminated and gas contaminated biochar at 110°C of 5% and 4.5% respectively, but only 1.7% in the NC biochar. In proximate analyses, this weight loss is attributed to moisture but in this case a component of this figure could be attributed to condensed organic compounds that have been vaporized at low temperatures.

Table 1 indicates in the case of all biochar samples, nearly the same relative amount of volatiles release above the pyrolysis process temperature of the biochars (550°C). This is also depicted in Figure 4, where the slopes of low-VOC biochar and high-VOC biochar weight loss curves above pyrolysis temperature are the same (in Figure 4 only LC is depicted but GC biochar showed exactly the same pattern). However, during heating of the samples to pyrolysis temperature (i.e. between 110-550°C), the contaminated biochars lost a much higher fraction of weight compared to the low-VOC biochar. Obviously, as already described (see section 2.1) the contamination of the two biochars occurred due to compounds that vaporized during the pyrolysis process to 550°C initially but re-condensed in the solid product because of low temperature in certain areas of the unit. LC and GC biochar contained a 10% higher proportion of volatile matter than NC biochar and potentially organic compounds disguised within the 'moisture fraction'.

As shown in Table 1, NC biochar had a pH of 7.12 whereas the contaminated biochars had a pH of 3.64. Typically, the pH of wood biochar at produced at mid-pyrolysis temperatures is between 6.7-7.9 (Calvelo Pereira et al., 2011; Mukome et al., 2013; Ronsse et al., 2013), but in one instance, a pine biochar (<450°C, fast pyrolysis) was stated to have a pH of only 3.9 (Smith et al., 2013). The acidic nature of the re-condensed pyrolysis liquids are the reason for the low pH of contaminated biochars (Fagernas et al., 2012), which originated from the degradation of cellulose, hemicellulose and lignin and the formation of acetic acid and other organic acids during pyrolysis (Fagernas et al., 2012; Spokas et al., 2011).



## 3.2 Assessment of phytotoxicity of VOCs and mitigation methods

### 3.2.1 Effect of volatiles

Germination rate for 'volatile only' tests can be seen in Table 2. The vapours released from NC biochar showed no toxic effect on cress seeds and germination rates were close to 100% in all NC biochar treatments and in the controls (controls not shown in Table 2). Yet, the vapours emitted from LC and GC biochars were highly inhibitive to germination. The use of biochar amounts > 0.5 g fully suppressed the germination of cress seeds (Table 2). Even 0.5 g of high-VOC biochars led to significant reductions in the rate of germination compared to the control (GC:  $p < 0.001$ ; LC:  $p < 0.001$ ) while 0.25 g resulted in a non-significant reduction in rate (GC:  $p = 0.164$ ; LC:  $p = 0.150$ ) (Figure 5). There were no toxic effects identified in the volatile fraction of the 'all exposure routes' germination test, except for a slight but significant decrease of germination for the highest LC treatment (LC 5% compared to control:  $p = 0.014$ ) (Figure 6). This can be explained by the fact that biochar was incorporated into sand and leached with water, which reduced potential of VOC to be vaporized.

The impact of volatiles on seed germination from high temperature biochars (800-860°C) produced from different feedstocks has been tested before. Barley seed germination showed no inhibition (Bargmann et al., 2013). Nevertheless, proximate analyses have shown that high temperature biochars possess a lower volatile matter concentration compared to biochar produced at lower temperatures and so less/no toxic effects would be expected for high temperature biochars (Ronsse et al., 2013). In a similar pyrolysis experiment carried out by Busch et al. (2012), peanut hull biochar produced at 500°C did show inhibition of germination and on hypocotyl (shoot) growth, however, this was attributed to an adverse effect caused by a moisture shortage and not due to toxicity (Busch et al., 2012). Furthermore, in the study one year old biochar was used and therefore a large amount of volatile compounds might have dispersed over this time (Busch et al., 2012).

### Simple storage

It has been stated that processing, handling and storage of biochar led to reduction of volatile organic compounds, and these seem to be the most relevant factors which determine the profile of VOC sorbed to biochar (Spokas et al., 2011). Thus, biochar storage was chosen as a suitable parameter to investigate effects on mitigation of toxicity. The 0.5 g GC biochar treatment showed a significant improvement from close to 0% germination for unstored samples to nearly 100% for stored biochar ( $p < 0.001$ ) (Figure 5). In the LC treatment this effect was less pronounced. Storage did not mitigate toxicity or improve germination rates in treatments with more than 0.5 g biochar, all showed total inhibition of germination (apart from 1 g stored GC biochar which improved germination rate to 4%) (Table 2). Tests with 0.5 g of stored GC biochar showed similar toxicity as 0.25 g non stored GC biochar treatment and an

1 increase in amounts of biochar in both treatments decreased germination strongly,  
2 thus, a twofold reduction of toxicity was achieved while the storage of LC biochar  
3 showed a smaller improvement.

4 It is clear that this type of storage of contaminated biochars was a poor measure to  
5 reduce toxicity and it is unlikely that the contaminated biochars would release  
6 vapours continuously in high amounts even after 4 weeks. This indicates that; even  
7 small amounts of vapours released after 4 weeks of storage are highly toxic or, the  
8 introduction of stored biochar into the germination test jars led to an additional peak  
9 of vapour release. A reason for desorption of VOCs after storage could be the  
10 increased moisture content due to the water reservoir in the closed jars used during  
11 the germination tests. It has been shown for soil that a water saturated  
12 nitrogen/helium stream desorbs a higher fraction of compounds than a dry stream,  
13 due to displacement of VOC by water (Thibaud et al., 1993; Yeo et al., 1997).  
14 However, in the case of activated carbon sorption/desorption behaviour showed both  
15 no influence (Delage et al., 1999) and decreased sorption (thus increased  
16 desorption) (Li et al., 2008) due to increased relative humidity. Only when water has  
17 a higher affinity to the solid material than the respective VOC is it able to displace  
18 VOC and facilitate desorption (hydrophobicity of the solid and the kind of VOC  
19 determine these affinities). Soil has a higher affinity to water than to VOCs (Thibaud  
20 et al., 1993) and for activated carbon it is reported to be the opposite due to  
21 hydrophobic surfaces (Delage et al., 1999). It remains unclear if biochar rather has a  
22 higher affinity to water or to VOCs, thus if relative humidity increases VOC  
23 desorption.

24 The use of short term storage (4 weeks) was deemed to be unsuitable to reduce  
25 toxicity of biochars with very high VOC content. Potentially, storage parameters  
26 could be improved to result in higher performance, e.g. by increasing temperature.

27

### 28 **Blending of low and high VOC biochar**

29 The potential for low-VOC biochar to sorb organic vapours from contaminated  
30 biochar and thus reduce their inhibition of germination was tested through the  
31 blending of low and high VOC biochar. The 'volatiles only' germination tests showed  
32 a reduction in toxicity due to blending (Table 2 and Figure 7). Treatments of 1 and 2  
33 g LC and GC biochar without blending led to total inhibition of germination (Table 2)  
34 while blending of 1 g of GC biochar with 9 g of NC biochar (10%) resulted in a similar  
35 germination rate as the control, but 2 g GC blended with 8 g NC (20%) resulted in no  
36 improvement (Figure 7). However, 1 g LC biochar, when blended, greatly improved  
37 the germination rate to around 50% (Table 2 and Figure 7).

38 The 0.25 g non-blended GC biochar (Figure 5) treatment was slightly more toxic than  
39 1 g blended treatment (Figure 7), thus the toxicity was reduced by at least a factor of  
40 4 due to blending. For LC biochar the toxicity was reduced to a smaller degree.

1 Di Lonardo et al. (2013) observed that biochar (poplar, 550°C, pyrolytic stove)  
2 decreased concentrations of gaseous ethylene in closed glass vials and decreased  
3 negative influences on plant growth. The same effect could explain the reduced  
4 toxicity when LC and GC samples were blended with NC biochar, due to the ability of  
5 low VOC biochar to adsorb more toxic VOCs.

6 Blending of contaminated biochars and low-VOC biochars appears to reduce the  
7 toxicity of VOC from contaminated biochars. Nonetheless, as the large standard  
8 deviation of germination rate in the 20% LC treatment shows (Figure 7) the effect  
9 can be highly variable. An explanation for this variability could be that only one or a  
10 few compounds are responsible for germination inhibition and could already effect  
11 germination in low concentrations. As soon as biochar cannot adsorb any more  
12 compounds, germination inhibition occurs. The adsorption capacity in the 80% NC  
13 biochar treatment could have reached this limit, and in some replicates, when highly  
14 toxic VOCs could not be trapped anymore, they were released and caused near total  
15 inhibition of germination. Yet, poor blending of the two biochars could also have  
16 caused non-consistent release of VOCs during the replicate runs.

17

### 18 **Volatiles effect in practice**

19 Major negative effects on seed germination by VOC were noted, however, it is  
20 difficult to assess what impact volatile organic compounds from biochar will have on  
21 plant germination and growth in practice. Biochar handling does have a major impact  
22 on amounts and composition of volatiles in biochar (Spokas et al., 2011). It has been  
23 reported that vapours released from hydrochar caused toxicity in closed containers  
24 but not when free gas exchange was ensured (Bargmann et al., 2013). The 'all  
25 exposure routes' experiment confirmed that vapours from fresh contaminated  
26 biochars in a wetted sand (soil) mixture causes little toxicity, which indicates this  
27 could also be the case if applied in agricultural soil. Still, it has been reported for  
28 hydrochar, most vapours causing toxicity are water soluble (Bargmann et al., 2013).  
29 This seems to be the case also for contaminated biochars, as leaching reduced  
30 toxicity of the volatile fraction dramatically. The toxicity of the resulting leachate and  
31 biochar is discussed in the following section.

32

### 33 **3.2.2 Effects of water soluble compounds and direct biochar contact**

34 The liquid fraction in the 'all exposure routes' germination test (affected by volatiles  
35 as well as by the leachate from the biochar/sand mixture) showed very strong  
36 negative effects on germination (Figure 6). In the highest treatment (5%) both  
37 contaminated biochars inhibited germination almost completely (6% GC; 0% LC). In  
38 the 1 and 2% LC biochar treatments in which no significant effect on germination  
39 could be detected, a shift of root length fraction to a greater proportion of smaller  
40 roots was visible. Obviously, water soluble compounds from biochar can cause high  
41 toxicity on seed germination. NC biochar was also tested and seeds showed 100%

1 germination rate in all biochar concentrations (Supplementary Table 1). Furthermore,  
2 positive effects on plant growth (roots) was observed, agreeing with reports for most  
3 biochars (Jeffery et al., 2011; Lehmann and Joseph, 2009) (Supplementary Figure  
4 1).

5 In the 'solid fraction', seeds were in direct contact with biochar and were additionally  
6 exposed to dissolved compounds and released gases. As expected due to exposure  
7 to all toxic routes, this treatment demonstrated the highest level of germination  
8 inhibition with 1% of contaminated biochar in soil leading to detrimental effects on  
9 germination (45% GC; 25% LC) and growth (entire roots smaller 15 mm).

10 It can be clearly seen (Figure 6) that direct contact with seeds increased biochar  
11 toxicity compared to seed contact only with leachates. But it needs to be noted that  
12 the seed contact systems were different, thus, water supply might have been  
13 different and might have influenced germination. Yet, the controls on filter paper and  
14 on biochar/sand mixture all showed 100% seed germination indicating that the  
15 contact system didn't have any (negative) influence. Gell et al (2011) demonstrated  
16 that pig manure digestate biochar produced at 300°C caused major toxicity on  
17 germination due to salt stress and/or dissolvable phytotoxic organic compounds (Gell  
18 et al., 2011). It was suggested that biochar containing high ash content can cause  
19 negative effects due to salt stress (Busch et al., 2012). However, LC, GC and NC  
20 biochars had ash contents of less than 2% which makes it unlikely that the ash  
21 content caused salt stress toxicity. Thus, the higher toxicity due to direct contact  
22 compared to leachate only was potentially caused by a higher concentration of  
23 dissolved organics in close contact to biochar.

24 The toxic effects of water extracts from biochar have been investigated before with  
25 extracts from high volatile matter charcoal (macadamia nut shell, 430°C)  
26 demonstrating reduced germination of radish and corn seeds (Deenik et al., 2010). It  
27 has been reported that three out of six biochar extracts from different feedstocks and  
28 highest treatment temperatures decreased seedling growth but did not have an  
29 influence on germination (Rogovska et al., 2012). In another study pine biochar  
30 extracts (450°C) exhibited toxic effects on blue-green and green algae (Smith et al.,  
31 2013). Furthermore, biochar extracts from different feedstocks showed variable  
32 negative impacts on aquatic species of several organism groups (bacteria, algae,  
33 crustacea, protozoa) (Oleszczuk et al., 2013). These studies confirm that biochar  
34 can possess readily water soluble compounds that can have negative impact on  
35 different organisms. In all four above mentioned studies, biochar was extracted by  
36 shaking with water. Yet, in this study, biochar was simply leached by water that  
37 percolated through a biochar/sand mixture and still this resulted in highly toxic  
38 leachate. These results show that acute toxic compounds in biochar can be  
39 dissolved easily into water and could potentially be readily transported into soil,  
40 leached into groundwater and also taken up by organisms. It is difficult, however, to  
41 assess the degree of which re-condensation affects biochar produced in other  
42 pyrolysis units and if mobile organic compounds might have been responsible for

1 some of the variable results of plant response in field and greenhouse trials  
2 (Biederman and Harpole, 2013; Spokas et al., 2011) as no studies on these factors  
3 could be found.

4

### 5 **3.3 Nature of toxicity**

6 It has been shown that high phytotoxic effects are associated with mobile  
7 compounds from biochar, but how does this affect plant growth and which factors are  
8 responsible?

9 In the 'volatiles only' germination test, four treatments showed a significant reduction  
10 of shoot length compared to the control (GC SS 0.25:  $p = 0.024$ ; GC OS 0.5:  $p =$   
11  $0.013$ ; LC SS 0.25:  $p = 0.028$ ; LC OS 0.5:  $p = 0.023$ ) and LC OS 0.5 showed a  
12 significant reduction on root length ( $p = 0.009$ ) (Figure 5). This could be attributed to  
13 direct negative effects on growth after germination but it was observed that the listed  
14 treatments showed delayed germination; no visible germination after 48 h except  
15 from the control (Supplementary Figure 2). Delayed germination could have resulted  
16 in reduced time for growth and so resulting in reduced shoot and root length.  
17 Delayed germination was also seen for barley seeds exposed to volatiles from  
18 hydrochar (unsealed conditions) (Bargmann et al., 2013). This shows that the most  
19 sensitive parameter for toxicity of mobile compounds from biochar is germination  
20 rate and changes in shoot and root length only seem to be a result of inhibition of  
21 germination.

22 One potential underlying cause for reduced germination could be low pH of  $<5$ ,  
23 leading to total or close to total inhibition of seed germination on filter paper for  
24 various plant species (Shoemaker et al., 1990). By measuring the pH of filter paper it  
25 was identified that in the 'volatile only germination test' the filter paper of the high  
26 biochar treatments (10 g) had a pH of around 4.5 (Table 3). Nevertheless, in the  
27 lower treatments (1, 2, 5 g), the pH increased and reached neutral values (5.3-7.0),  
28 but still no germination was observed. In a study of eight plant species, it was  
29 reported that a pH of 5.5 to 7.5 is the optimum pH for germination (Shoemaker et al.,  
30 1990). This clearly shows that the reduced pH in the experiments outline here might  
31 have contributed to the inhibition of seed germination, but is not the sole cause. A  
32 pine wood biochar extract with a pH of 3.9 showed toxic effects on algae; yet, even  
33 when the pH was neutralized the toxic effects still occurred. This confirms that  
34 soluble compounds from biochar can cause direct toxicity (Smith et al., 2013).

35 PAHs were the main compounds identified as potential causes for toxicity of water  
36 extracts so far (Oleszczuk et al., 2013; Rogovska et al., 2012). However, PAH  
37 bioavailability/water solubility in biochar is reported to be very low (Hale et al., 2012),  
38 furthermore, PAHs are rather semi-volatile or non-volatile (Ferreira, 2001). Thus,  
39 PAHs in biochar can't be considered mobile which makes it unlikely that PAHs are  
40 the cause for toxicity in the germination tests. A more detailed study proposed that

1 the toxicity of biochar extracts could be a result of phenolic species (Smith et al.,  
2 2013).

### 3 **4 Conclusions**

4 Re-condensation of liquids and gases during pyrolysis resulted in biochar with a high  
5 content of organic compounds that are released below pyrolysis temperature. These  
6 volatiles are highly mobile and showed strong toxic effects on cress seed  
7 germination, both in vapour form and dissolved in water, indicating potential  
8 problems in the use of this type of biochar for soil amendment.

9 Two methods, storage and blending, for reducing toxicity of high-VOC biochar were  
10 tested. The results showed that despite the high potential of VOC to vaporize/to be  
11 released, simple open-air storage proved insufficient for toxicity reduction, at least  
12 within the range investigated. On the other hand, blending of high-VOC biochar with  
13 low-VOC biochar showed positive synergy and effective reduction of toxicity was  
14 demonstrated.

15  
16 The phytotoxic effects of the biochar samples might be attributed partly to a  
17 reduction in pH caused by volatiles and dissolved compounds. However, it doesn't  
18 explain the toxic effects in all cases. Since salt and water stress were excluded as  
19 causes for the inhibition, it was deduced that mobile organic compounds were most  
20 likely responsible for the undescribed adverse effects on germination. It is yet  
21 unclear which compounds are being accountable (with phenolic compounds being  
22 only one suspect category), and detailed studies to identify them are necessary, and  
23 a natural next step. There is a need to investigate the re-condensation of pyrolysis  
24 vapours for different pyrolysis facilities as the degree of re-condensation is unique to  
25 the individual unit. Variable plant responses observed in previous studies might be  
26 explained by this phenomenon of mobile organic compounds and therefore it is very  
27 important to continue research in this area. Findings in this work open up a new area  
28 of research of high importance to biochar development and application.

29  
30  
31  
32  
33  
34  
35  
36

## 1 5 References

- 2 Bargmann, I., Rillig, M.C., Buss, W., Kruse, A., Kuecke, M., 2013. Hydrochar and  
3 biochar effects on germination of spring barley. *J. Agron. Crop Sci.* 199, 360–  
4 373.
- 5 Bernardo, M., Lapa, N., Gonçalves, M., Barbosa, R., Mendes, B., Pinto, F.,  
6 Gulyurtlu, I., 2010. Toxicity of char residues produced in the co-pyrolysis of  
7 different wastes. *Waste Manage.* 30, 628–35.
- 8 Biederman, L.A., Harpole, W.S., 2013. Biochar and its effects on plant productivity  
9 and nutrient cycling: a meta-analysis. *GCB Bioenergy* 5, 202–214.
- 10 Busch, D., Kammann, C., Grünhage, L., Müller, C., 2012. Simple biotoxicity tests for  
11 evaluation of carbonaceous soil additives: establishment and reproducibility of  
12 four test procedures. *J. Environ. Qual.* 41, 1023–1032.
- 13 Buss, W., Kammann, C., Koyro, H.-W., 2012. Biochar reduces copper toxicity in  
14 *Chenopodium quinoa* Willd. in a sandy soil. *J. Environ. Qual.* 41, 1157–1165.
- 15 Calvelo Pereira, R., Kaal, J., Camps Arbestain, M., Pardo Lorenzo, R., Aitkenhead,  
16 W., Hedley, M., Macías, F., Hindmarsh, J., Maciá-Agulló, J. a., 2011.  
17 Contribution to characterisation of biochar to estimate the labile fraction of  
18 carbon. *Org. Geochem.* 42, 1331–1342.
- 19 Cordella, M., Torri, C., Adamiano, A., Fabbri, D., Barontini, F., Cozzani, V., 2012.  
20 Bio-oils from biomass slow pyrolysis: a chemical and toxicological screening. *J.*  
21 *Hazard. Mater.* 231-232, 26–35.
- 22 Crombie, K., Mašek, O., Sohi, S.P., Brownsort, P., Cross, A., 2013. The effect of  
23 pyrolysis conditions on biochar stability as determined by three methods. *GCB*  
24 *Bioenergy* 5, 122–131.
- 25 Deenik, J.L., McClellan, T., Uehara, G., Antal, M.J., Campbell, S., 2010. Charcoal  
26 volatile matter content influences plant growth and soil nitrogen transformations.  
27 *Soil Sci. Soc. Am. J.* 74, 1259–1270.
- 28 Delage, F., Pascaline, P., Le Cloirec, P., 1999. Effect of moisture on warming of  
29 activated carbon bed during VOC adsorption. *J. Environ. Sci.* 1160–1167.
- 30 Di Lonardo, S., Vaccari, F.P., Baronti, S., Capuana, M., Bacci, L., Sabatini, F.,  
31 Lambardi, M., Miglietta, F., 2013. Biochar successfully replaces activated  
32 charcoal for in vitro culture of two white poplar clones reducing ethylene  
33 concentration. *Plant Growth Regul.* 69, 43–50.
- 34 Elad, Y., Cytryn, E., Harel, Y.M., Lew, B., Graber, E.R., 2011. The Biochar Effect:  
35 plant resistance to biotic stresses. *Phytopathol. Mediterr.* 50, 335–349.

- 1 Fabbri, D., Rombolà, A.G., Torri, C., Spokas, K.A., 2012. Determination of polycyclic  
2 aromatic hydrocarbons in biochar and biochar amended soil. *J. Anal. Appl.*  
3 *Pyrolysis* 103, 60–67.
- 4 Fagernas, L., Kuoppala, E., Simell, P., 2012. Polycyclic aromatic hydrocarbons in  
5 birch wood slow pyrolysis products. *Energy Fuels* 26, 6960–6970.
- 6 Ferreira, M.M., 2001. Polycyclic aromatic hydrocarbons: a QSPR study.  
7 *Chemosphere* 44, 125–146.
- 8 Freddo, A., Cai, C., Reid, B.J., 2012. Environmental contextualisation of potential  
9 toxic elements and polycyclic aromatic hydrocarbons in biochar. *Environ. Pollut.*  
10 (Oxford, U. K.) 171, 18–24.
- 11 Gell, K., van Groenigen, J., Cayuela, M.L., 2011. Residues of bioenergy production  
12 chains as soil amendments: immediate and temporal phytotoxicity. *J. Hazard.*  
13 *Mater.* 186, 2017–2025.
- 14 Gomez-Eyles, J.L., Sizmur, T., Collins, C.D., Hodson, M.E., 2011. Effects of biochar  
15 and the earthworm *Eisenia fetida* on the bioavailability of polycyclic aromatic  
16 hydrocarbons and potentially toxic elements. *Environ. Pollut.* (Oxford, U. K.)  
17 159, 616–622.
- 18 Hale, S.E., Lehmann, J., Rutherford, D., Zimmerman, A.R., Bachmann, R.T.,  
19 Shitumbanuma, V., O'Toole, A., Sundqvist, K.L., Arp, H.P.H., Cornelissen, G.,  
20 2012. Quantifying the total and bioavailable polycyclic aromatic hydrocarbons  
21 and dioxins in biochars. *Environ. Sci. Technol.* 46, 2830–2838.
- 22 Hilber, I., Blum, F., Leifeld, J., Schmidt, H.-P., Bucheli, T.D., 2012. Quantitative  
23 determination of PAHs in biochar: a prerequisite to ensure its quality and safe  
24 application. *J. Agric. Food Chem.* 60, 3042–3050.
- 25 Huang, W., Chen, B., 2010. Interaction mechanisms of organic contaminants with  
26 burned straw ash charcoal. *J. Environ. Sci.* (Beijing, China) 22, 1586–1594.
- 27 International Biochar Initiative, 2013. Standardized product definition and product  
28 testing guidelines for biochar that is used in soil, v. 1.1.
- 29 Jeffery, S., Verheijen, F.G.A., van der Velde, M., Bastos, A.C., 2011. A quantitative  
30 review of the effects of biochar application to soils on crop productivity using  
31 meta-analysis. *Agric., Ecosyst. Environ.* 144, 175–187.
- 32 Lehmann, J., Joseph, S., 2009. *Biochar for Environmental Management: Science  
33 and Technology, Biochar for Environmental Management: Science and  
34 Technology.* Earthscan Ltd., London.
- 35 Li, J., Li, Z., Liu, B., Xia, Q., Xi, H., 2008. Effect of relative humidity on adsorption of  
36 formaldehyde on modified activated carbons. *Chin. J. Chem. Eng.* 16, 871–875.



- 1 Mukome, F.N.D., Zhang, X., Silva, L.C.R., Six, J., Parikh, S.J., 2013. Use of  
2 chemical and physical characteristics to investigate trends in biochar  
3 feedstocks. *J. Agric. Food Chem.* 61, 2196–2204.
- 4 Müller, K., Tintelnot, S., Leubner-Metzger, G., 2006. Endosperm-limited  
5 Brassicaceae seed germination: abscisic acid inhibits embryo-induced  
6 endosperm weakening of *Lepidium sativum* (cress) and endosperm rupture of  
7 cress and *Arabidopsis thaliana*. *Plant Cell Physiol.* 47, 864–877.
- 8 Ogbonnaya, U., Semple, K., 2013. Impact of biochar on organic contaminants in soil:  
9 a tool for mitigating risk? *Agronomy (Basel, Switz.)* 3, 349–375.
- 10 Oleszczuk, P., Joško, I., Kuśmierz, M., 2013. Biochar properties regarding to  
11 contaminants content and ecotoxicological assessment. *J. Hazard. Mater.* 260,  
12 375–382.
- 13 Rajkovich, S., Enders, A., Hanley, K., Hyland, C., Zimmerman, A.R., Lehmann, J.,  
14 2012. Corn growth and nitrogen nutrition after additions of biochars with varying  
15 properties to a temperate soil. *Biol. Fertil. Soils* 48, 271–284.
- 16 Rodríguez-Mirasol, J., Bedia, J., Cordero, T., Rodríguez, J.J., 2005. Influence of  
17 water vapor on the adsorption of VOCs on lignin-based activated carbons. *Sep.*  
18 *Sci. Technol. (Philadelphia, PA, U. S.)* 40, 3113–3135.
- 19 Rogovska, N., Laird, D., Cruse, R.M., Trabue, S., Heaton, E., 2012. Germination  
20 tests for assessing biochar quality. *J. Environ. Qual.* 41, 1014–1022.
- 21 Ronsse, F., van Hecke, S., Dickinson, D., Prins, W., 2013. Production and  
22 characterization of slow pyrolysis biochar: influence of feedstock type and  
23 pyrolysis conditions. *GCB Bioenergy* 5, 104–115.
- 24 Sánchez, M.E., Menéndez, J. a., Domínguez, a., Pis, J.J., Martínez, O., Calvo, L.F.,  
25 Bernad, P.L., 2009. Effect of pyrolysis temperature on the composition of the  
26 oils obtained from sewage sludge. *Biomass and Bioenergy* 33, 933–940.
- 27 Schimmelpfennig, S., Glaser, B., 2012. One step forward toward characterization:  
28 some important material properties to distinguish biochars. *J. Environ. Qual.* 41,  
29 1001–1013.
- 30 Sfetsas, T., Michailof, C., Lappas, A., Li, Q., Kneale, B., 2011. Qualitative and  
31 quantitative analysis of pyrolysis oil by gas chromatography with flame ionization  
32 detection and comprehensive two-dimensional gas chromatography with time-  
33 of-flight mass spectrometry. *J. Chromatogr. A* 1218, 3317–3325.
- 34 Shoemaker, C.A., Carlson, W.H., Hort, B., Hook, I., 1990. pH affects seed  
35 germination of eight bedding plant species. *HortScience* 25, 762–764.
- 36 Singh, B., Singh, B.P., Cowie, A.L., 2010. Characterisation and evaluation of  
37 biochars for their application as a soil amendment. *Aust. J. Soil Res.* 48, 516–  
38 525.

- 1 Smith, C.R., Buzan, E.M., Lee, J.W., 2013. Potential impact of biochar water-  
 2 extractable substances on environmental sustainability. *ACS Sustain. Chem.*  
 3 *Eng.* 1, 118–126.
- 4 Spokas, K.A., Novak, J.M., Stewart, C.E., Cantrell, K.B., Uchimiya, M., Dusaire,  
 5 M.G., Ro, K.S., 2011. Qualitative analysis of volatile organic compounds on  
 6 biochar. *Chemosphere* 85, 869–882.
- 7 Thibaud, C., Erkey, C., Akgerman, A., 1993. Investigation of the effect of moisture on  
 8 the sorption and desorption of chlorobenzene and toluene from soil. *Environ.*  
 9 *Sci. Technol.* 27, 2373–2380.
- 10 Yang, H., Kudo, S., Hazeyama, S., Norinaga, K., Mašek, O., Hayashi, J., 2013.  
 11 Detailed analysis of residual volatiles in chars from the pyrolysis of biomass and  
 12 lignite. *Energy Fuels* 27, 3209–3223.
- 13 Yeo, S.-D., Tuncer, E., Akgerman, A., 1997. Adsorption of volatile organic  
 14 compounds on soil and prediction of desorption breakthroughs. *Sep. Sci.*  
 15 *Technol.* (Philadelphia, PA, U. S.) 32, 2497–512.
- 16

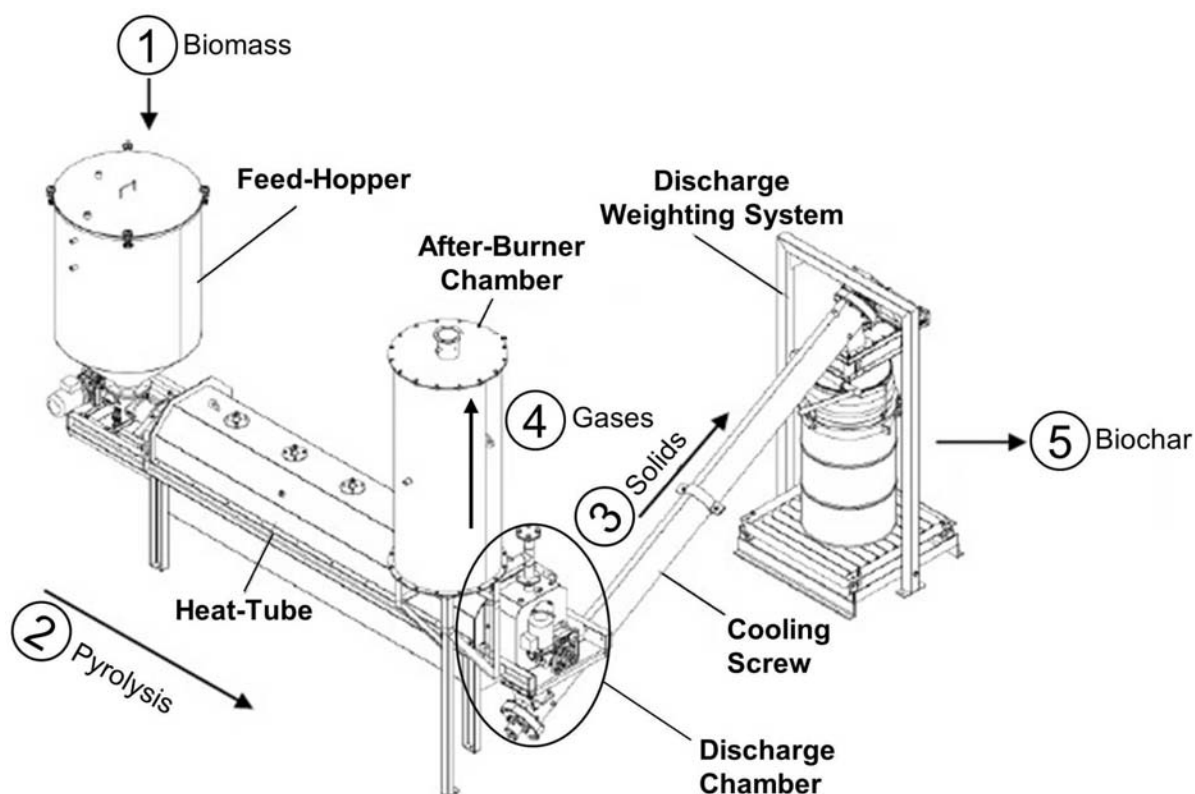

17

18 Figure 1: Schematic of pilot-scale rotary kiln pyrolysis unit UK Biochar Research  
 19 Centre

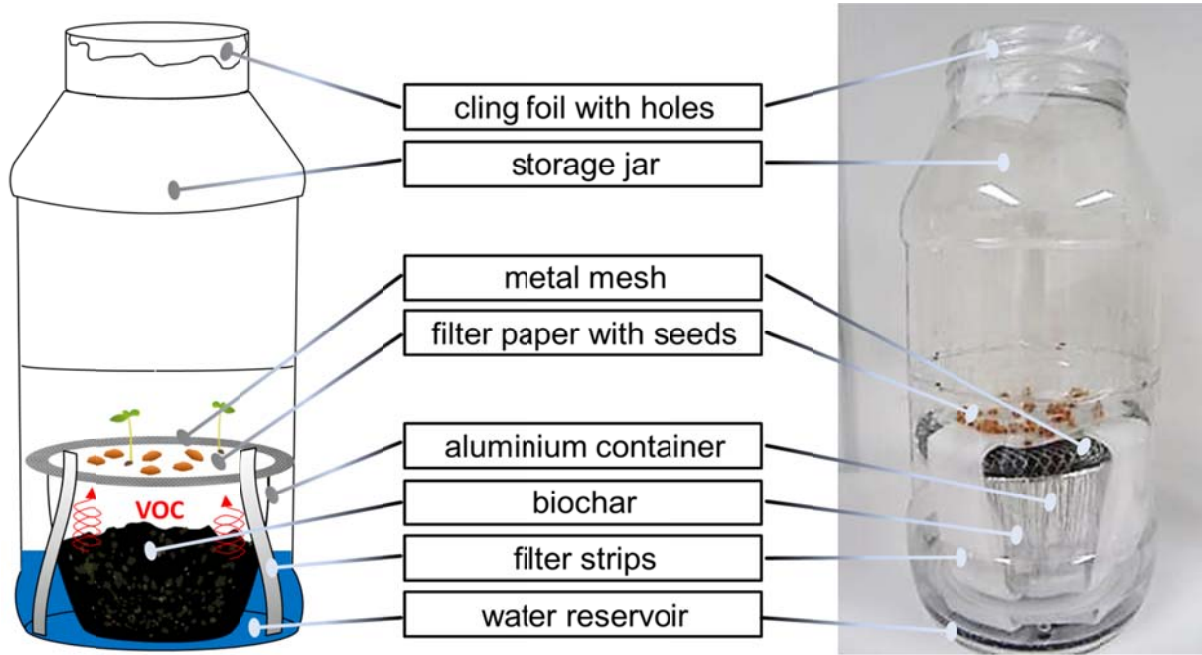

1

2 Figure 2: Schematic of the experimental setup for the 'volatiles only' germination test  
 3 for assessing effect of volatiles released from biochar on seed germination.

4

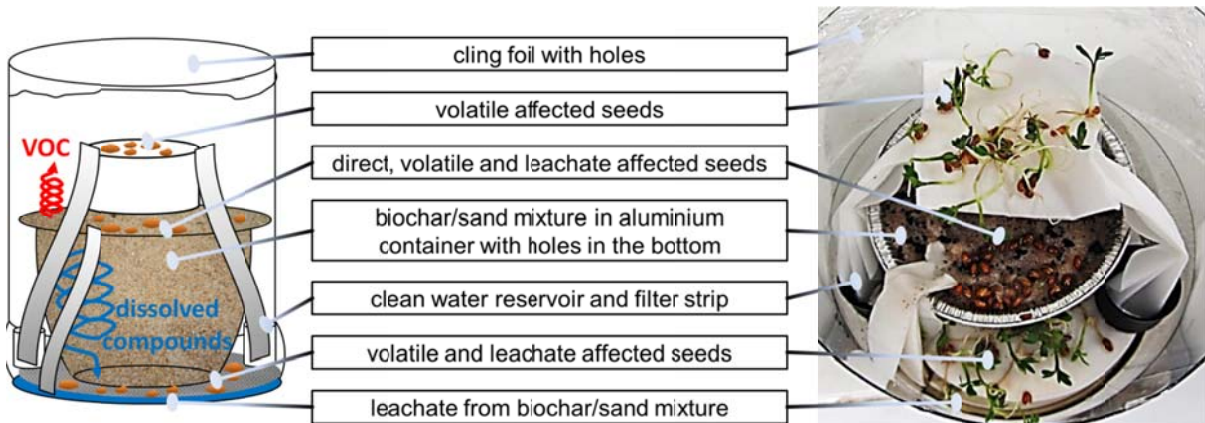

5

6 Figure 3: Schematic of the experimental setup for the 'all exposure routes'  
 7 germination test for assessing effect of volatiles released, compounds dissolved by  
 8 water and direct contact of biochar and seeds.

9

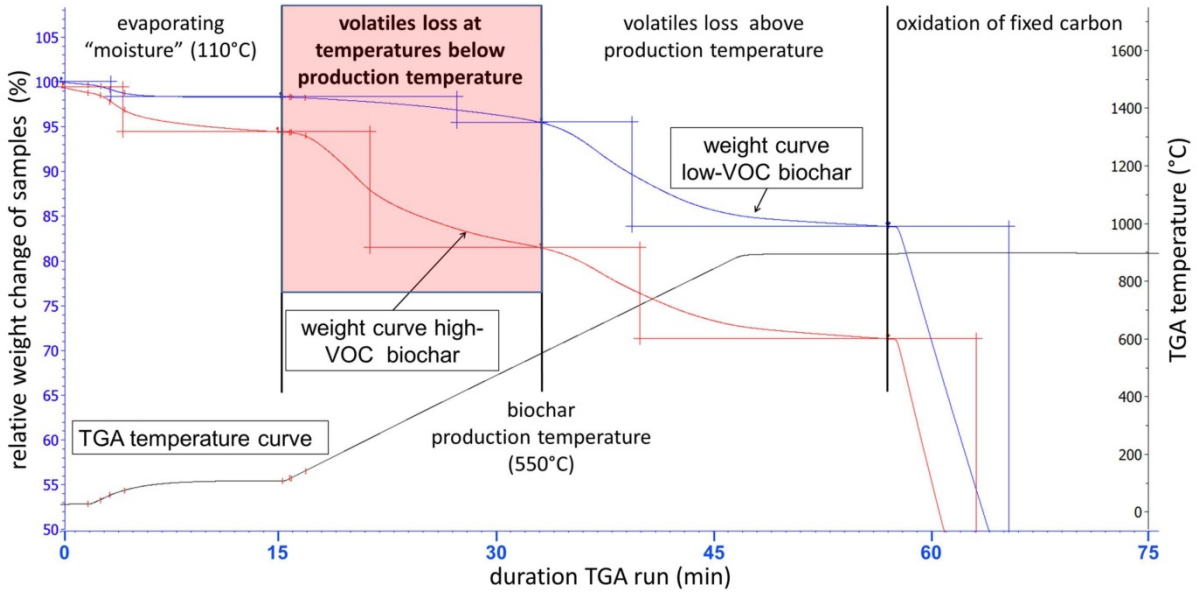

1

2 Figure 4: Temperature and weight loss curves of low-VOC and high-VOC (LC)  
 3 biochar during thermogravimetric analysis (TGA).

4

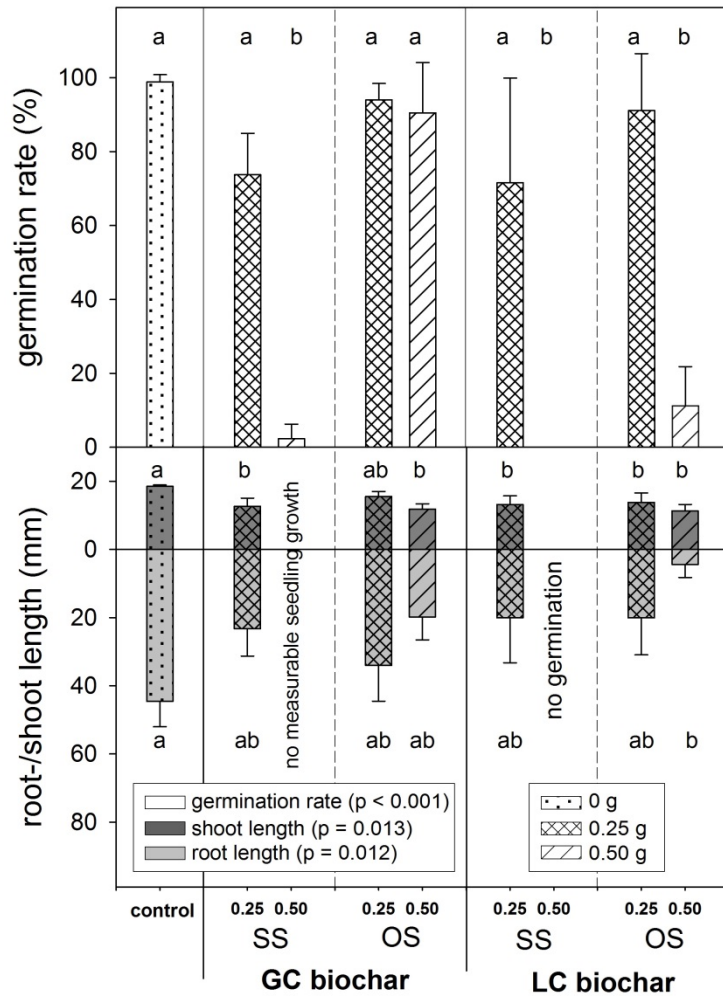

5

1 Figure 5: Germination rate (%) and shoot-/root length (mm) of cress tested in a  
 2 'volatiles only germination' test using different amounts of biochar. LC and GC  
 3 biochar were tested using sealed storage (SS) and open storage (OS) for 4 weeks.  
 4 Different letters indicate significant differences between the treatments.

5

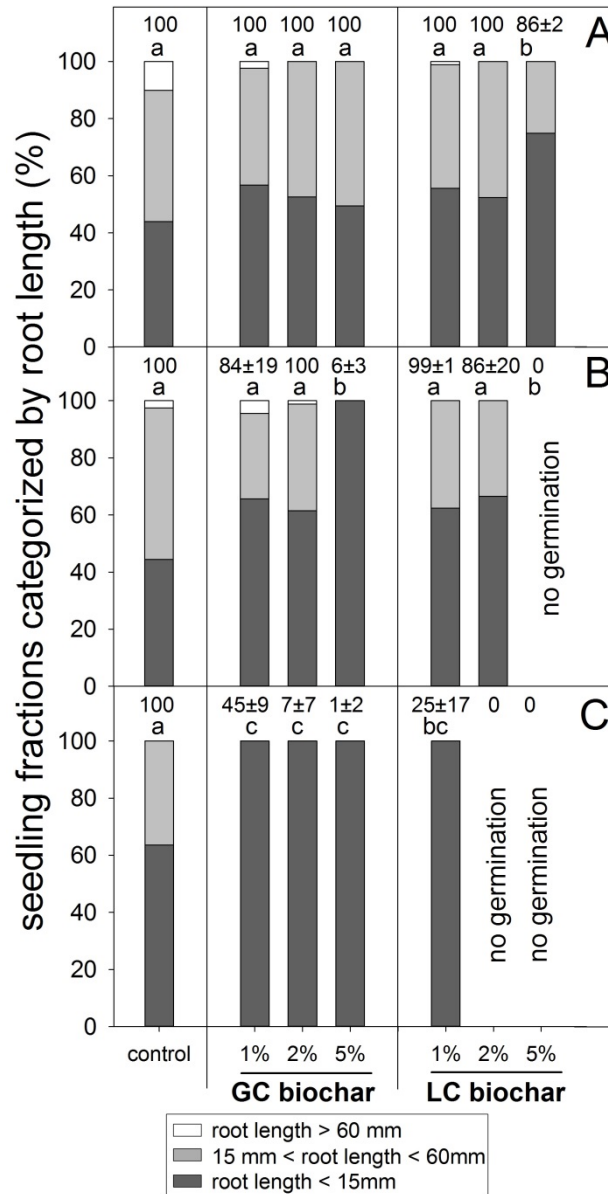

6

7 Figure 6: Germination rate (%) as values and seedling fractions (%) with root growth  
 8 < 15 mm, between 15 and 60 mm and above 60 mm as bars are depicted. 'All  
 9 exposure routes' germination test was performed assessing toxicity of gaseous  
 10 compounds released (A), leachable compounds (B) and direct contact of seeds and  
 11 biochar (C). Two high-VOC biochars (GC and LC) were tested in sand (w/w).  
 12 Germination rate is given as averages with standard deviation and letters indicate  
 13 significant differences of germination rate between the treatments.

14

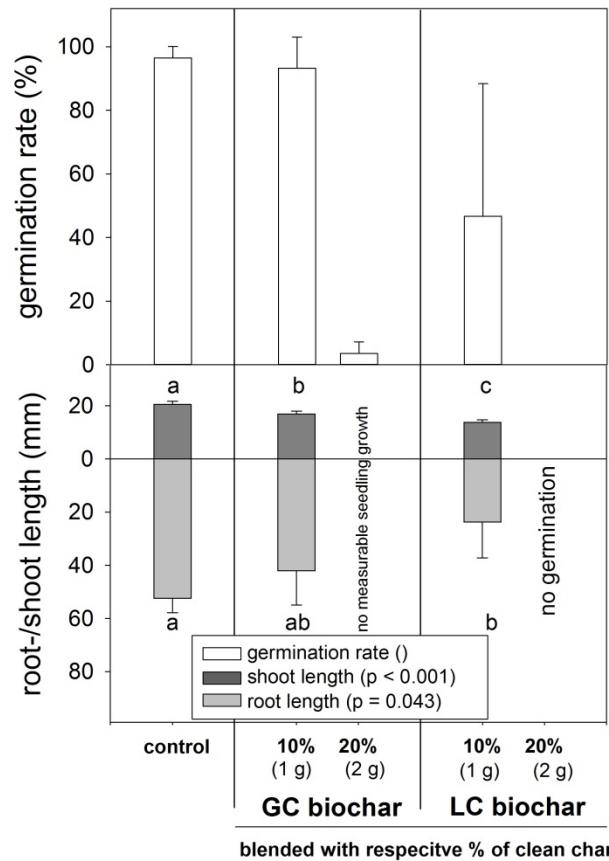

1

2 Figure 7: Germination rate (%) and shoot-/root length (mm) of cress tested in a  
 3 'volatiles only germination'. High-VOC biochars (LC and GC) were blended with low-  
 4 VOC biochar as measure to reduce phytotoxicity. In total 10 g of blended sample  
 5 was used. Different letters indicate significant differences between the treatments.  
 6 No statistical analysis was performed for parameter germination rate (data were not  
 7 normally distributed and transformations to gain normal distribution were  
 8 unsuccessful).

9

10

11

12

13

14

15

16

17

18

19

20

21

22

23

24

1 Table 1: Characteristics of low-VOC and two high-VOC biochars. Proximate analysis performed by TGA. pH-determination in  
 2 solution. RT = residence time, % daf = % dry, ash free basis

biochar	VOC	feedstock	temperature (°C)	RT (min)	pH ( )	moisture (%)	ash (%)	fixed C (% daf)	volatile matter		
									total VM (% daf)	<550°C <sup>a</sup> (% daf)	>550°C <sup>b</sup> (% daf)
non-contaminated (NC)	low	softwood pellets	550°C	20 min	7.12	1.71	1.67	85.05	14.95	2.95	12.37
gas contaminated (GC)	high	softwood pellets	550°C	20 min	3.64	4.47	1.93	73.67	26.33	15.48	12.85
liquid contaminated (LC)	high	softwood pellets	550°C	20 min	3.64	4.96	1.21	75.43	24.57	13.90	12.39

<sup>a</sup>volatile matter content released <550°C calculated based on dry, ash free basis

<sup>b</sup>volatile matter content released >550°C calculated based on total mass at TGA temperature of 550°C (excluding moisture, ash and volatiles lost < 550°C)

1 Table 2: Effect of GC and LC biochar amounts on the germination rate (%) during  
 2 'volatile only' germination tests with cress. Samples were either stored in sealed  
 3 containers (SS) or openly (OS) for 4 weeks.

biochar	storage	amount used (g)				
		30	10	5	2	1
		germination rate (%)				
non contaminated (NC)	sealed	98	97	98	99	97
	open	99	100	100	98	100
gas contaminated (GC)	sealed	0	0	0	0	0
	open	0	0	0	0	4
liquid contaminated (LC)	sealed	0	0	0	0	0
	open	0	0	0	0	0

4

5

6 Table 3: Determination of pH of filter paper from 'volatiles only' germination tests  
 7 using openly stored (OS) and seal (SS) LC and GC biochar in different amounts. nt =  
 8 not tested.

amount (g)	low-VOC biochar		GC biochar		LC biochar	
	SS	OS	SS	OS	SS	OS
0.25	nt	nt	7.0	6.5	7.3	6.8
0.5	nt	nt	6.5	6.5	6.7	6.8
1	6.8	6.7	6.2	6.3	5.5	6.0
2	7.0	7.0	6.2	6.3	5.3	5.5
5	6.7	6.0	6.0	6.3	5.3	5.5
10	6.8	6.2	5.0	5.2	4.5	4.5

9