



THE UNIVERSITY *of* EDINBURGH

Edinburgh Research Explorer

Laser system and method for operating laser system

Citation for published version:

Hands, PJW, Wilkinson, TD, Morris, SM & Coles, HJ 2013, Laser system and method for operating laser system, Patent No. WO2013017881, IPC No. H01S 3/102.

Link:

[Link to publication record in Edinburgh Research Explorer](#)

Document Version:

Publisher's PDF, also known as Version of record

General rights

Copyright for the publications made accessible via the Edinburgh Research Explorer is retained by the author(s) and / or other copyright owners and it is a condition of accessing these publications that users recognise and abide by the legal requirements associated with these rights.

Take down policy

The University of Edinburgh has made every reasonable effort to ensure that Edinburgh Research Explorer content complies with UK legislation. If you believe that the public display of this file breaches copyright please contact openaccess@ed.ac.uk providing details, and we will remove access to the work immediately and investigate your claim.





- (51) International Patent Classification:
H01S 3/102 (2006.01) *H01S 3/23* (2006.01)
 - (21) International Application Number:
PCT/GB2012/051869
 - (22) International Filing Date:
2 August 2012 (02.08.2012)
 - (25) Filing Language: English
 - (26) Publication Language: English
 - (30) Priority Data:
1113324.6 2 August 2011 (02.08.2011) GB
 - (71) Applicant (for all designated States except US): **CAMBRIDGE ENTERPRISE LIMITED** [GB/GB]; The Old Schools, Trinity Lane, Cambridge, Cambridgeshire CB2 1TN (GB).
 - (72) Inventors; and
 - (75) Inventors/Applicants (for US only): **COLES, Harry James** [GB/GB]; The Old Meeting House, 33 High Street, Sutton, Ely, Cambridgeshire CB6 2RB (GB). **HANDS, Philip J. W.** [GB/GB]; 91 Lancaster Gate, Upper Cambourne, Cambridge, Cambridgeshire CB23 6AU (GB). **MORRIS, Stephen Matthew** [GB/GB]; 45 Weavers Field, Girton, Cambridge, Cambridgeshire CB3 0XB (GB). **WILKINSON, Timothy David** [GB/GB]; Jesus College, Jesus Lane, Cambridge, Cambridgeshire CB5 8BL (GB).
 - (74) Agents: **NAYLOR, Matthew** et al.; Mewburn Ellis LLP, 33 Gutter Lane, London, Greater London EC2V 8AS (GB).
 - (81) Designated States (unless otherwise indicated, for every kind of national protection available): AE, AG, AL, AM, AO, AT, AU, AZ, BA, BB, BG, BH, BN, BR, BW, BY, BZ, CA, CH, CL, CN, CO, CR, CU, CZ, DE, DK, DM, DO, DZ, EC, EE, EG, ES, FI, GB, GD, GE, GH, GM, GT, HN, HR, HU, ID, IL, IN, IS, JP, KE, KG, KM, KN, KP, KR, KZ, LA, LC, LK, LR, LS, LT, LU, LY, MA, MD, ME, MG, MK, MN, MW, MX, MY, MZ, NA, NG, NI, NO, NZ, OM, PE, PG, PH, PL, PT, QA, RO, RS, RU, RW, SC, SD, SE, SG, SK, SL, SM, ST, SV, SY, TH, TJ, TM, TN, TR, TT, TZ, UA, UG, US, UZ, VC, VN, ZA, ZM, ZW.
 - (84) Designated States (unless otherwise indicated, for every kind of regional protection available): ARIPO (BW, GH, GM, KE, LR, LS, MW, MZ, NA, RW, SD, SL, SZ, TZ, UG, ZM, ZW), Eurasian (AM, AZ, BY, KG, KZ, RU, TJ, TM), European (AL, AT, BE, BG, CH, CY, CZ, DE, DK, EE, ES, FI, FR, GB, GR, HR, HU, IE, IS, IT, LT, LU, LV, MC, MK, MT, NL, NO, PL, PT, RO, RS, SE, SI, SK, SM, TR), OAPI (BF, BJ, CF, CG, CI, CM, GA, GN, GQ, GW, ML, MR, NE, SN, TD, TG).
- Declarations under Rule 4.17:**
— of inventorship (Rule 4.17(iv))

[Continued on next page]

(54) Title: LASER SYSTEM AND METHOD FOR OPERATING LASER SYSTEM

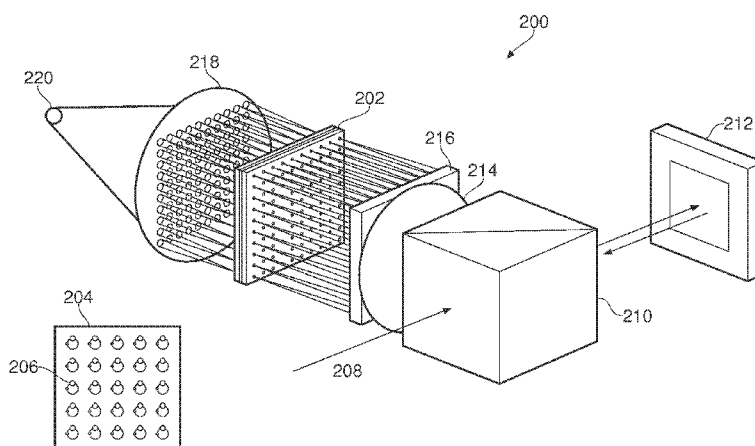

FIG. 4

(57) Abstract: A laser system comprises a pump source, a lasing medium and a spatial intensity control means. The pump source is operable to generate pumping radiation directed to the lasing medium via the spatial intensity control means. The position of the lasing medium is fixed with respect to the position of the pump source. The lasing medium has a spatial extent to allow the pumping radiation to excite lasing at different locations in the lasing medium over time. The spatial intensity profile of the pumping radiation incident at the lasing medium is varied over time using the spatial intensity control means. The spatial intensity is controlled by time-varying reflection, refraction and/or interference of the pumping radiation.

