



# THE UNIVERSITY *of* EDINBURGH

## Edinburgh Research Explorer

### Tales of the 1001 Nists. The Phonological Implications of Litteral Substitution Sets in 13th-century South-West-Midland texts

**Citation for published version:**

Laing, M & Lass, R 2003, 'Tales of the 1001 Nists. The Phonological Implications of Litteral Substitution Sets in 13th-century South-West-Midland texts' *English Language and Linguistics*, vol 7, no. 2, pp. 1-22., <http://dx.doi.org/10.1017/S1360674303001102>

**Digital Object Identifier (DOI):**

<http://dx.doi.org/10.1017/S1360674303001102>

**Link:**

[Link to publication record in Edinburgh Research Explorer](#)

**Document Version:**

Publisher final version (usually the publisher pdf)

**Published In:**

English Language and Linguistics

**General rights**

Copyright for the publications made accessible via the Edinburgh Research Explorer is retained by the author(s) and / or other copyright owners and it is a condition of accessing these publications that users recognise and abide by the legal requirements associated with these rights.

**Take down policy**

The University of Edinburgh has made every reasonable effort to ensure that Edinburgh Research Explorer content complies with UK legislation. If you believe that the public display of this file breaches copyright please contact [openaccess@ed.ac.uk](mailto:openaccess@ed.ac.uk) providing details, and we will remove access to the work immediately and investigate your claim.



# English Language and Linguistics

<http://journals.cambridge.org/ELL>

Additional services for *English Language and Linguistics*:

Email alerts: [Click here](#)

Subscriptions: [Click here](#)

Commercial reprints: [Click here](#)

Terms of use : [Click here](#)



---

## Tales of the 1001 nists: the phonological implications of litteral substitution sets in some thirteenth-century South-West Midland texts

MARGARET LAING and ROGER LASS

English Language and Linguistics / Volume 7 / Issue 02 / November 2003, pp 257 - 278  
DOI: 10.1017/S1360674303001102, Published online: 29 October 2003

**Link to this article:** [http://journals.cambridge.org/abstract\\_S1360674303001102](http://journals.cambridge.org/abstract_S1360674303001102)

### How to cite this article:

MARGARET LAING and ROGER LASS (2003). Tales of the 1001 nists: the phonological implications of litteral substitution sets in some thirteenth-century South-West Midland texts. *English Language and Linguistics*, 7, pp 257-278 doi:10.1017/S1360674303001102

**Request Permissions :** [Click here](#)

## **Tales of the 1001 nists: the phonological implications of litteral substitution sets in some thirteenth-century South-West Midland texts<sup>1</sup>**

MARGARET LAING, *University of Edinburgh*

ROGER LASS, *University of Cape Town*

(Received 17 September 2002; revised 29 May 2003)

There are two main strands to this paper. The first is that in Middle English – and early Middle English especially – there are many writing systems that are so complex as to seem disorderly. But a sympathetic and careful interpretation of these systems shows sophisticated underlying order. The second strand is related to the first: early Middle English writing systems are local and may be represented on maps. When complex systems are assigned geographical positions close to each other – and indeed close to where simpler, more economical systems are localized – a picture emerges that can appear haphazard and unlike the dialect continuum we would expect. We refer to this phenomenon as surface nubbliness. This masks the underlying regional dialect continuum we believe to have been present in the spoken language. But knowledge of how these written systems mapped symbol to sound may enable us to uncover a continuum at the level of sound substance.

### 1 Prodigality in early Middle English writing systems

It is a familiar but misleading view that many early Middle English spelling traditions are ‘irregular’ or ‘chaotic’. This ‘irregularity’ is at its most striking in some South-West Midland writing systems, which contrast maximally with the economy and regularity of the neighbouring AB language. The continued misunderstanding of such complex systems is a relic of the view – so elegantly and finally interred by the late Cecily Clark (1992: 117–29) – that writers of early Middle English were ‘confused Anglo-Norman scribes’.

However, we can now assume that the ‘Anglo-Norman scribes’ must in fact have been native speakers of English who had been trained in the writing of Latin and French, and were now turning their skills to the problem of writing their native language (Benskin, in prep.). Their orthographic toolkit comprised the sets of conventions used for Anglo-French and Latin, and a greater or lesser individual knowledge of monuments from the time when English was an actively written vernacular with a living tradition.

<sup>1</sup> A version of this paper was first delivered at the 12th International Conference on English Historical Linguistics, Glasgow 2002. Michael Benskin, Bob Stockwell, and Peter Kitson made particularly helpful comments. We are also grateful to Keith Williamson for further suggestions and for producing the maps and to Michael Benskin for comments on the written version. We thank the Arts and Humanities Research Board for supporting the work at the Institute of Historical Dialectology, University of Edinburgh, which provided the basis for this paper. We also thank the Faculty of Humanities of the University of Cape Town for generous leave provision and financial support.

We begin with some assumptions, which will allow us to avoid consigning the bulk of early Middle English – other than the more economical AB language and Ormish – to the categories ‘careless’ or ‘confused’. Some of the best-known ‘confused’ systems are those of Laḡamon A scribes A and B, Laḡamon B (Otho text) or Cambridge, Trinity College B.14.39 (323),<sup>2</sup> scribes A and D. In this article we will be concentrating on Trinity, Scribe A.

### 1.1 Assumptions

- (a) Our texts are the products of native English-speaking professionals who knew what they were doing.
- (b) These native speakers were writing for audiences of other native speakers.
- (c) The audience and producers of the texts shared a corpus of linguistic knowledge.

The term ‘native-speaking audience’ includes both ordinary readers or hearers and copying scribes using the texts as exemplars.<sup>3</sup>

- (d) The apparent disorder of many of these systems is an artefact of our *own* present lack of understanding. The mutual expectations of medieval scribes and their readers were very different from the present-day equivalent. Writing systems could be prodigal yet still systematic.<sup>4</sup>
- (e) The scribes were capable of sophisticated and subtle linguistic analysis. This can be demonstrated without anachronistically attributing to them any uniquely modern theoretical concepts. Nothing we claim here is incompatible with the medieval doctrine of *littera*, or what intelligent scribes may be presumed to have understood by it.

### 1.2 The medieval doctrine of *littera*

*Littera* is a postclassical taxonomic notion which ties together coherently both the written and the spoken representations of language. The canonical definition for medieval writers is probably that in book 1 of Donatus’s *Ars Maior*:

Littera est pars minima vocis articulatae...littera est vox, quae scribi potest individua... accidit uni cuique litterae tria, nomen figura potestas. quaeritur enim, quid vocetur littera, qua figura sit, quid possit.<sup>5</sup>

<sup>2</sup> For an excellent edition of the Trinity texts with parallel texts of those that survive also in other manuscripts, see Reichl (1973).

<sup>3</sup> The term exemplar could include a composing scribe’s own rough copy.

<sup>4</sup> For a detailed explication of scribal encoding, decoding, and re-encoding and the contrast between disciplined, economical systems and complex prodigal ones in our period see Laing (1999).

<sup>5</sup> ‘Littera is the smallest unit of articulated sound...littera is (a) sound which is capable of being written alone...littera has three aspects: name, shape, [sound] value. For one must ask what a letter is called, what shape it has and what sound it has’ [our translation]. This is somewhere between a translation and a gloss; it is easier to do this than to give detailed discussion of Donatus’s metalanguage. For an enlightening discussion in the context of medieval orthographic theory and reform see Benediktsson (1972: §3.2). The quotations from Donatus are taken from Benediktsson (1972: §3.2.2.1). Here, as elsewhere, we adopt, for the most part, the conventions established by Michael Benskin (1997: 91 fn. 1 and 2001: 194 fn. 4). *Litterae*, independently of any manuscript rendering, are enclosed in single inverted commas. The *figurae* of particular manuscripts are

## 2 Litteral substitution sets

We now briefly unpack our assumptions, by means of a worked example. On fol. 83v of Trinity 323, Scribe A writes a version of the lyric *Respice in faciem* (Brown, 1924: 61–2).<sup>6</sup> Consider the following four-line extract:

is hewid him al abutim<sup>7</sup>  
 wid þornis iprikic  
 is faire hondin ant is waire wed  
 wid naylis ystickic.<sup>8</sup>

Let us consider the form *wed* in line 3. How is this to be interpreted? On the basis of this excerpt alone, we can assume that the language belongs to an area with initial voicing of [f] to [v]. Note <f> ~ <w> in the word FAIR from OE *faeger* (cf. also <w> in *hewid*, HEAD from OE *hēafod*). Throughout this scribe's output, presumed OE /f/, whether intervocally or word-initially, is often written <w> (occasionally <p>) beside spellings in <f> and <v>/<u>: see examples (a)–(g) below.<sup>9</sup>

- (a) foure ~ voure FOUR
- (b) viwe ~ wype FIVE
- (c) feir ~ veir ~ weir FAIR
- (d) for- ~ vor- ~ wor- FOR-
- (e) vuele ~ huuele ~ huvel EVIL
- (f) fel ~ vel ~ wel FALL pret sg.
- (g) ful ~ uul ~ vul ~ wl FULL

Using the concept of *littera* introduced in the previous section, we can now define {‘f’, ‘u’, ‘v’, ‘w’, ‘p’} as a litteral substitution set (LSS) in Scribe A's usage (cf. Laing,

enclosed in angle brackets. Citations from manuscript are in italics, or Roman for longer citations and displays. Abbreviations are expanded into the *litterae* to which they correspond, and printed in Roman (or in italic in longer citations that are otherwise in Roman). Italics are also used for citation of Old English ‘dictionary forms’ and for starred etymologies. *Potestates* are represented by IPA symbols in square brackets. Glosses and word-identities are in small capitals.

<sup>6</sup> In the manuscript the lyric is written in seven long lines with internal as well as end rhyme. We have relineated our extract for ease of reading, as Brown does.

<sup>7</sup> Brown reads this as *abutun*, presumably taking the word simply as ABOUT. However, the scribe did not actually write *-un*. Scribe A does not tend to join his minim strokes for ‘n’, ‘m’, ‘u’ either at top or foot, but here the first minim stroke of the four is clearly marked with a superior oblique stroke, the scribe's usual disambiguation for ‘i’ in minim clusters. *Him* earlier in the line is interlined above the rest of the text, apparently also by Scribe A. It is possible that this was a hypercorrection, as it leaves us with two realizations of the pronoun HIM, the second cliticized to the postposition. Other versions of *Respice in faciem* have different wording here so textual comparison gives no help. There is a case to be made for *abutun* being a ‘better’ reading syntactically, as it would avoid the apparently awkward double dative. But there is no doubt that scribe A intended *-im*; however, by this time the *m/n* contrast in final unstressed syllables was marginal. For a discussion of a number of historical issues involving the *n/m* interchange in this position see Britton (1994).

<sup>8</sup> Brown prints both examples of final <c> as <t>. The shape in the manuscript is clearly <c>. The two *figurae*, although distinct in shape, seem to be used interchangeably, a practice not uncommon in hands of this date. We retain the figural representation here rather than printing <t>, because we wish to emphasize the visual complexity of the orthography. <c> presumably implies the *potestas* [t] – the weak past participle ending in Scribe A's system is most often spelled <-it> beside less frequent <-ed(e)>, <-eit>, <-et>, <-id>, <-iet>.

<sup>9</sup> All examples are taken from the corpus in preparation for *A Linguistic Atlas of Early Middle English*.

1999).<sup>10</sup> As long as a word can be identified, it appears to be optional which member of an LSS is used for a particular segment.<sup>11</sup>

We also find numerous forms suggesting morpheme-final devoicing of voiced stops, or at least neutralization of the voice contrast:

- (a) hond ~ hont HAND; god ~ got GOD;
- (b) bringen ~ brinken BRING inf.;
- (c) ewensonc EVENSONG; breit BREAD.

To complete the picture, we have inverse spellings:

- (a) þat ~ þad 'that'; wat ~ vad WHAT
- (b) þeng THINK imper.; wrid WRIT sb.

The interpretation of *wed* is then straightforward:

- (1) <w> is a member of the LSS {'f', 'u', 'uu', 'p'}, all of which can represent etymological [f], or more likely [v].
- (2) <e> is unproblematic except for ambiguous length.
- (3) <d> belongs (via devoicing) to the LSS {'t', 'd'}.
- (4) Therefore *wed* ≡ 'vet'/'fet' = [ve:t] = FEET

The scribe was clearly not 'confused', and if *we* could figure this out a contemporary reader of Scribe A's language is likely also to have been able to do so. What is particularly interesting is the relative ease of interpretation using nothing but systematic litteral substitution evidence; in fact there are many more immediate and powerful clues, such as the collocation, which is clearly 'hands and feet'.

### 2.1 Decoding a prodigal writing system

Figure 1 is a possible model of the process that a reader of an early Middle English text, written in a system different from his own, might have undertaken to understand the text. Note that in the diagram <x> is a purely notional *figura* and [i] a purely notional *potestas*. The reader<sup>12</sup> reads some *figura* <x>, and assesses which *potestas*

<sup>10</sup> We use the terms *littera* and *litteral* to refer to the abstract idea of 'the letter', which can be realized by a number of different shapes or *figurae*. Of course in medieval terms <u/v> are in fact *figurae* of a single *littera*, which *littera* has both vocalic and consonantal uses, hence as *littera* 'u'. Moreover, <w> is ligatured <vv> so as *littera* should more properly be realized as 'uu'; see Benskin (2001: 211–12). Our LSS above may therefore more correctly be rendered {'f', 'u', 'uu', 'p'}. It is sometimes also necessary to invoke a *Figural Substitution Set* (FSS) where, for instance, a single <p>-shaped *figura* can be used to represent any or all of the *potestates* implied by <p>, <p> or <y> while a distinct *figura* <ɣ> may sometimes also share some or all of the same *potestates* (Laing, 1999: 255–9); cf. also the discussion in fn. 8 above implying the FSS {<c>, <t>}. This extra degree of complexity is, however, not needed for the present discussion (though note *syikel*, which appears once in Scribe A's usage, for OE *swicol* where the use of the *figura* <y> to imply the *potestas* [w] was probably influenced by an exemplar whose usage allowed for the FSS noted above: {<p>, <p>, <y>}).

<sup>11</sup> In practice the choices are not unconstrained. Certain lexemes appear to be preferentially written with particular members of the substitution set: see appendix 1 for examples.

<sup>12</sup> Who may be a copying scribe having to decode the writing system of the exemplar before being able accurately to re-encode the text into his own system. This is not to imply that our model is isomorphic to any mental reality.

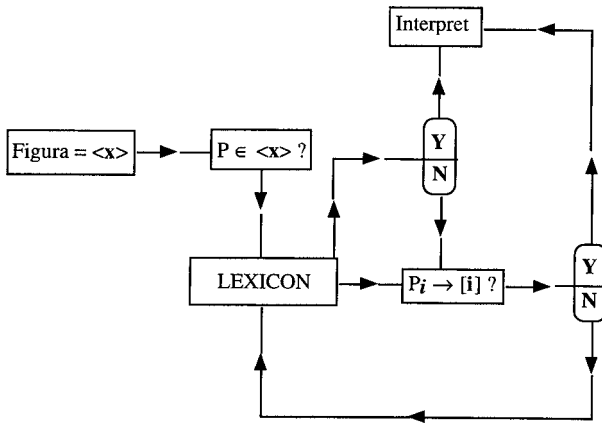

Figure 1. Inferential unpacking in Litteral Substitution Sets

(P) could map to the LSS of which *figura* <x> is a member. The set may not map one on one, *figura* to *potestas*. He therefore needs to consult his lexicon; if he finds only one possible candidate he can infer which LSS member the <x> here represents. There may, however, be more than one possible candidate (e.g. *wed* could also ‘spell’ the following words in early Middle English: *WED* vb. imper.; *WEDD* = ‘pledge’ n.; the reflexes of OE *wēdan* GO MAD pres. 3rd sg. and ppl.; *WEED* (< OE *wēod*); *WEED*(s) = ‘garments’ (< OE *wāed*); and, by virtue of the kind of LSSs illustrated above, also just feasibly, *WET* vb. imper. and pres. 3rd sg.; *WET* adj.; *WHAT* pron. or adj.; *VAT* n.; *FEED* vb. imper., pres. 3rd sg., pret sg. or ppl.; *FETCH* ppl., *FAT* adj. In cases where more than one P may map onto the figura <x>, the reader must ask himself ‘does P<sub>i</sub> have the sound [i]?’ and return to the lexicon to examine the potential candidates. Each visit to the mental lexicon must also take into account the context of the word: the word class required by syntax, semantics, and morphology. Further considerations such as metre and rhyme may also apply. Sophisticated users of early Middle English writing systems were not surprisingly able to interpret even the most complex and profligate of LSSs. Despite our formalism, interpretation requires hardly more than analogical reasoning.

### 3 The mapping of spelling variants to spoken variants

Now consider this stanza from a poem on the Passion found in Trinity 323, fol. 33rb, also copied by Scribe A. We can tell that this is a stanza from the initial paraph and prominent capital and the fact that the poem (of 120 lines) has a consistent rhyme-scheme *a b a b c c d c c d*.

§ **L** auedi flur of parradis  
 Nas neuir non so ssene  
 Ber hure herrinde if þi vilhis  
 Asse þu ard heuene quene  
 To þine sone þat is so **brit**  
 þat he us þeue strenþe 7 **mist**

Lady flower of paradise,  
 was never none so beautiful.  
 Bear our errand if it is thy will,  
 as thou art queen of heaven,  
 to thy son who is so bright,  
 that he may give us strength and might,

To <i>seruen</i> him wid <i>wu<sup>m</sup>e</i>	to serve him with joy
7 to scenden þene <b>vichit</b>	and to confound the devil (wight),
þat his humbe day 7 <b>nicst</b>	who is around day and night
To gabben us wid <i>su<sup>m</sup>e</i>	to deceive us with sin.

Given the metrical structure, it is incumbent on the reader to interpret *brit*, *mist*<sup>13</sup>; *vichit*, *nicst* as rhyming. Lexical identity is unproblematic, especially given such collocations as *strenþe 7 mist* (which is unlikely to be read as ‘strength and mist’), and even more obviously *day 7 nicst*.

So these are to be read as rhyming – but *on what?* This question raises some important issues:

1. This particular quartet of rhymes shares a proximate etymology in OE *-iht*.
2. If Scribe A (as the structure suggests) intends only one possible phonetic rhyme, why does he use four different spellings? Does the presence of four distinct spellings permit the existence of more than one pronunciation for any or all of these words? In practice things may be simpler: we may be looking at only two possible spoken variant types, one with a short vowel and some fricative before the <t>, the other with a long vowel and no fricative. There could in principle have been more than one fricative realization. In this text, given its date, NIGHT could have had any combination of the realizations [nixt], [niçt] (depending on whether or not there was palatalization),<sup>14</sup> [niht], or [ni:t] with compensatory lengthening after fricative loss.
3. Is Scribe A drawing attention (playfully or not) to such potential ambiguities? Is he aware of more than one possible pronunciation in his own and/or other idiolects? Is he implicitly permitting the reader to adopt his/her ‘favourite’ rhyming realization for a quartet such as this?<sup>15</sup>

### 3.1 *Potestatic substitution sets*

The graphic set {<-it>, <-ist>, <-ichit>, <-icst>} constitutes (part of) an LSS. The existence of an LSS implies an associated set which we will call a potestatic<sup>16</sup> substitution set (PSS).<sup>17</sup> We have in fact specified the content of our putative PSS under

<sup>13</sup> To minimize possible confusion in the light of our later argument, we should say that the *s* here does not imply [s], but is apparently an inverse spelling based on the Old French sound change [st] > [xt~çt~ht] which persisted in Anglo-Norman into the late thirteenth or fourteenth century (Pope, 1934 [1952]: §§1178(ii) and 1216 and refs. there cited).

<sup>14</sup> Even though the usual assumption is that /x/ was palatalized after front vowels, this may be a ‘Germanophone’ prejudice. Velar or uvular realizations of Germanic \*x after front vowels are the norm in Northern Dutch, Afrikaans, Yiddish, and Swiss German.

<sup>15</sup> Even a standardized spelling can grant implicit permission for variant pronunciations – e.g. Byron, *On the Castle of Chillon*: ‘Brightest in dungeons Liberty thou art/For there thy habitation is the heart’. In Byron’s time both rhotic and nonrhotic pronunciations would have been available and known in the Southern standard. (Cf. Lass, 1997: ch 6; 1999: 114–16.)

<sup>16</sup> This is our nonce formulation: there is no available Latinate adjective based on *potestas*. We use this term to avoid the standard implications of ‘phonological’ and ‘phonemic’. For further discussion see appendix 3.

<sup>17</sup> It is perfectly possible for a one-member LSS to be associated with a one-member PSS given normal set-theoretic definitions.



point 2 above: {[nixt], [niçt], [niht], [ni:t]}. Since the LSS and the PSS are intended to be well-formed sets in the mathematical sense, it is possible for mappings between them to be taken as one to one, one to many or many to one. What kind of mapping we have in any given case is not a theoretical but an empirical question. The Corpus version of *Ancrene Wisse*, in the contrastingly regular AB system, has only <-ht> in the four lexemes that appear in our stanza. All LSS to PSS mappings for this etymological segment in the AB system appear to be unique.<sup>18</sup> The LSS to PSS mappings in Trinity Scribe A's system appear to be many to (probably) two.<sup>19</sup>

### 3.2 *A contemporary spelling reformer*

It may seem that we are attributing excessive cleverness to scribes and/or readers, expecting such indirect and inference-driven strategies of representation and interpretation. Surely this could be an example of the very anachronism we claim to avoid? But it clearly is not: the strategy is described (as something to be stigmatized) by a contemporary commentator on writing and its interpretation, the Icelandic First Grammarian (fl. c. 1200). The FG is a spelling reformer, a convinced one-sound-one-graph advocate, who devises a new orthography for Icelandic which does away entirely with literal ambiguity. In a straw-man dialogue designed to support his new system, he describes alternative possibilities for interpreting more prodigal systems. He sets up as opposed figures the 'guesser' and the 'seeker' or profiter by exactitude. After a short argument to the effect that every language must be written with all and only the letters proper to its own sound system, he remarks:<sup>20</sup>

Now it could happen that someone will speak up this way: I can read the Danish [= Norse] language perfectly well, even if it's written with the normal Latin letters. I can make out what it says, even if all the letters I read are not correctly pronounceable [réttræðir].<sup>21</sup> [...] My reply: it is not the virtue of the symbols<sup>22</sup> that enables you to read and interpret where the letters are ambiguous. That is rather *your* virtue; and it is not to be expected

<sup>18</sup> Unless we grant the possibility of variant or changing pronunciations for some or all of these words in the spoken system underlying the AB script. In such a case the PSS to LSS mappings would be many to one, but the surviving evidence gives no indication of this.

<sup>19</sup> Cf. the LSS for OE *-ht* in Trinity Scribe D's system: {<-ct>, <-st>, <-t>, <-th>, <-ch>, <-cht>, <-dt>, <-tht>, <-tt>, <-ʒt>, <-d>} (see Laing, 1999: 258; 2001: 33 fn. 73).

<sup>20</sup> Our translation, partly after Benediktsson (1972: 212–15) and Haugen (1950: 14–15). Like the translation of Donatus, this one is to some extent pedagogical and expository, not merely literal. See Benediktsson for the Icelandic text itself and a closer but more complex translation, Haugen for a looser and more colloquial one.

<sup>21</sup> The word *réttræðir* literally means 'correctly pronounceable'. The FG's orthographical theory is based on a kind of 'universal phonetics': each *littera* represents one of the set of possible sound types that occur in natural languages, so that there is one and only one 'correct' reading (in fact stipulated, but in theory quasi-platonically representative of a 'form' or 'essence'). A more elaborate version with commentary can be found in the treatise *De Loquela* which prefaces Wallis (1653).

<sup>22</sup> It is not entirely clear whether the FG wants to make a distinction between the various words that Haugen and Benediktsson indifferently translate 'letter'. The usual equivalent of *littera* is *staf* (cf. OE *stæf*, G *Stab*; here however the FG uses *rinar* (normally 'runes', but also 'secret lore, wisdom': Zoëga (1910) s.v. *runar*). This may be slightly sardonic; the FG is obsessed with clarity, and he could be implying that a letter is not much better than a 'rune' for the kind of reader who is willing to guess.

that I or anyone like me (if such a person could be found) would be able to read properly, and make out which paths to travel where several are possible because the text is written one way – but ambiguously. And then you have to guess, as you say you do so well. But even though everybody can make something or other of it, it is practically certain that they will not all get the same result when [a different reading] changes the meaning. So I tell you that you haven't answered well when you say we do not need these nine new vowels [that the FG has invented], especially if I can make thirty-six distinctions, each of which produces a different sound when it is properly distinguished.

#### 4 Excursus 'AB'

It is possible to put a text like Trinity Scribe A's stanza into an economical spelling system of the type that the FG would have approved. Since neighbouring speakers of the same language could undoubtedly understand one another, we can assume that neighbouring professional writers of the same language could read each other's systems, and translate them if desired into their own system. To illustrate the interconvertibility of prodigal and economical system types,<sup>23</sup> we present a version of our stanza in the very best AB language.<sup>24</sup> The version in the left column is that which the scribe of Corpus Christi College Cambridge 402 might have made for his own use if he had the version in the right column as his exemplar. It is assumed that he is a translating scribe rather than a literatim copyist.

##### *Constructed AB version*

Leafdi flur of parais  
 Nes neauer nan spa schene  
 Ber ure ernde ʒef ʔi pil is  
 As ʔu art heuene cpen  
 To ʔi sune ʔe is spa briht  
 ʔ he us ʒeoue strengðe 7 miht  
 To serui him pið punne  
 7 to schenden ʔe piht  
 ʔe is umbe dei 7 niht  
 To gabben us pið sunne

##### *Trinity A version for comparison*

§ 1. auedi flur of parradis  
 Nas neuir non so ssene  
 Ber hure herrinde if ʔi vilhis  
 ASSE ʔu ard heuene quene  
 To ʔine sone ʔat is so brit  
 ʔat he us ʔeue strenʔe 7 mist  
 To seruen him wid wunne  
 7 to scenden ʔene vichit  
 ʔat his humbe day 7 nicst  
 To gabben us wid sunne

Given the close geographical proximity of the writing systems of Trinity Scribe A and of the designer of AB language,<sup>25</sup> it is likely that a local reader, even of two such

<sup>23</sup> For a similar illustration in which an extract from the *Ormulum* is 'de-Ormified' and a contemporary early Middle English text subjected to Orm's phonemic systematization, see Laing (2000: 116–17).

<sup>24</sup> Note that every word in this text conversion may be found in the Cambridge, Corpus Christi College 402 version of *Ancrene Wisse* (A) (see Potts, Stevenson & Wogan-Browne, 1993), and/or in Oxford, Bodleian Library, Bodley 34 (B). However, the following words do not appear in AB language in the relevant morphological form and have been reconstructed from the forms that do appear: 'flower' appears in AB only in the plural, *flur(e)s*, and the word *ārend* only in forms of the related verb; the 'AB' infinitive *gabben* is created from *gabbeð*, 3rd sg. pres. For editions see Tolkien (1962), d'Ardenne & Dobson (1981), Mack (1934), d'Ardenne (1961), Millett (1982), and Wilson (1938).

<sup>25</sup> See the key to texts and key map below. The localizations are provisional. They have been arrived at by the fit technique, using both the early Middle English configuration and that for the later Middle English presented

superficially different texts, would have been able to read both. He would have been able to assign to both versions not only ‘some correct interpretation’ but perhaps even ‘the same one’; or perhaps the same choice of possible interpretations if more than one were available in his idiolect.

## 5 Implications for dialect maps

Our analysis of these scribal writing systems has an ulterior motive in relation to dialects, dialect map-making and the production of a Linguistic Atlas of Early Middle English (LAEME). The maps of later Middle English in *A Linguistic Atlas of Late Mediaeval English (LALME)* illustrate a continuum of written usage where the nonstandard forms of language vary in an orderly way across space. The early Middle English material *appears* much less coherent. The problem is two-fold:

1. Paucity of data points and unevenness of coverage make for genuine gaps in the evidence for the dialectal continuum that must have existed (Laing, 2000).
2. The unequal mapping of PSSs onto LSSs in different scribal systems blurs the confidently posited continuum, even in areas comparatively densely supplied with data points.

There are possible solutions to the difficulty in point 1, involving the manipulation of data in more abstract ‘computational space’.<sup>26</sup> Despite the surface nubbliness resulting from point 2, it does not follow that the dialectal continuum for this period is irrecoverable.

While a spelling reformer like the AB designer is clearly concerned with the technical issue of maximizing one-to-one mapping in his written system, his underlying spoken language need not have displayed the same relative conservatism and regularity. He *may* have had only the realization short vowel plus some particular fricative (indicated by <h>) before <t>. But it is also possible that any combination of the realizations [ixt], [içt], [iht] could be covered by the one spelling <-iht>,<sup>27</sup> whether or not equally across all words of the class ‘having OE *-iht*’.<sup>28</sup> It could be that the designer of AB language was willing to acknowledge the possibility (as in modern English) that variant pronunciations may nevertheless be realized in a single way in the interests of orthographic economy. Conversely, the comparative prodigality of the Trinity Scribe’s writing system suggests either that he was writing more phonetically, or that he was less interested in economical representation. His system, however, allows for the assumption

in *LALME*. While we make no claim to exactitude for the placings, we can assume that the two usages were current in places not much more than a day’s ride apart.

<sup>26</sup> For discussion see Williamson (2000). As far as LAEME is concerned, these problems will have to remain in abeyance until we have completed the tagging and initial map-making.

<sup>27</sup> This observation is based on the assumption that in AB language, <ht> spellings for OE *-ht* are a mark of conservatism. The use of <ht> in less conservative systems, however, could be an indication of weakening of the fricative.

<sup>28</sup> The evidence of consistent <-iht> spellings in these words in AB makes it impossible to know whether the pronunciation [i:t] with compensatory lengthening after fricative loss could also have been an option.

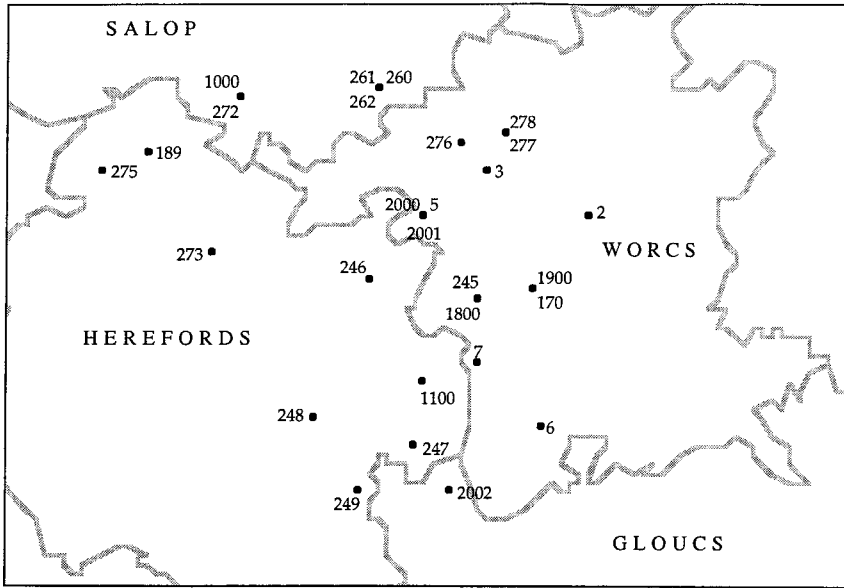

Map 1. Key map

of at least a two-tier pronunciation of OE *-iht* – [Vxt ~ VVt], where [x] may have any one of a number of fricative realizations.<sup>29</sup> The Trinity Scribe's system requires the recognition of distinct LSSs and PSSs, but the difference between his spoken system and that of the designer of AB in the present example may lie only in the (apparent) presence or absence of nonfricative realizations for words with OE *-iht*.<sup>30</sup>

To illustrate this point, we present the raw and partly processed material on which our discussion is based in the form of 'item lists' and maps. Appendix 1 shows spellings in some other SWML writing systems for the four rhyme words in our main example text by Scribe A of Trinity 323. Appendix 2 lists the early Middle English syllable rhyme spellings for OE *-iht* from 28 manuscript sources so far processed for LAEME and assigned to 20 different SWML locations (see map 1) in Herefords, Worcs, S. Salop and N. Gloucs. It gives LSS frequencies in individual texts without specification of particular lexical items. These are however retrievable from item lists similar to those presented in appendix 1. Appendix 3 simplifies further by providing for each source an LSS inventory without frequency marking. It conflates morphologically simple and

<sup>29</sup> The possibility that such spellings as <tht>, <tth>, <thth> (cf. La $\zeta$ mon B (Otho text) <pt>) may indicate some kind of dental fricative must also be considered.

<sup>30</sup> This endorses the view (Black, 1999: 155–74; Laing, 2000:120 fn. 8; Smith, 2000:131) that too much emphasis has been placed in the past on the 'standard' nature of AB language and other contemporary economical writing systems. These may profitably be compared with prodigal systems such as those of Trinity 323 scribes A and D whose usage may be the result of at least as careful analysis – if of a rather different kind. See Lass & Laing (forthcoming) for some illustration of the unexpected profligacy in certain aspects of AB language.



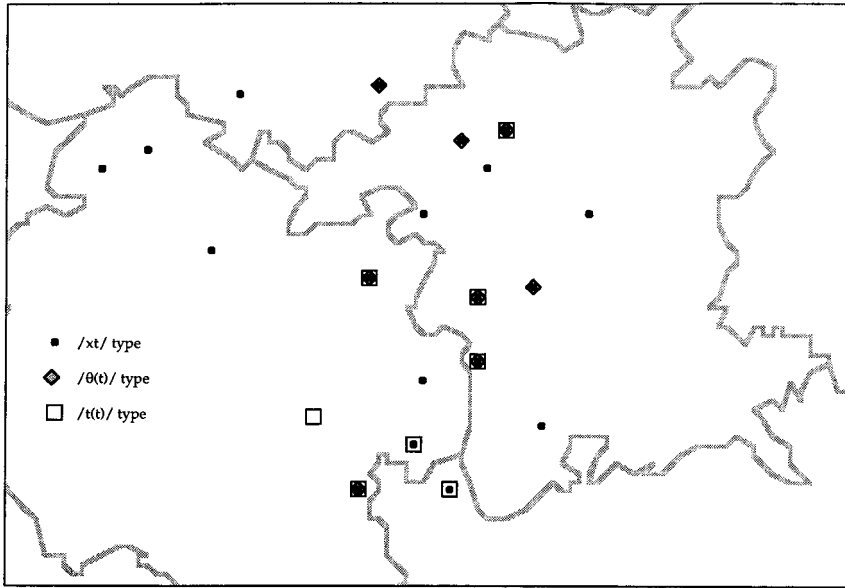

Map 4. Feature map of PSSs

## 6 Conclusions

The complexity displayed by some early Middle English writing systems arises from the availability, to a text community of multilingual writers, of large numbers of orthographic variants to realize certain sounds. The availability of these literal substitution sets may lead to writing systems of rich prodigality in the mapping of *littera* to *potestas*. But prodigal systems are still systematic and may be sensibly compared with economical ones. When orthographically contrasting systems are placed close to one another on the map, the recognition of potestatic substitution sets derived from the literal ones can reduce the appearance of complexity to a simpler orderliness. PSSs are based perforce on poorly resolved, broad phonetic realizations, but they still provide sufficient evidence for an underlying sound substance. For LAEME we suggest that the kind of orthographic maps familiar from *LALME* may be presented alongside potestatic maps derived from them to reveal in some part the continuum we believe to have existed for early Middle English dialects.

*Authors' addresses:*  
 Institute for Historical Dialectology  
 School of Philosophy, Psychology and Language Sciences  
 University of Edinburgh  
 24 Buccleuch Place  
 Edinburgh EH8 9LN  
 M.Laing@ed.ac.uk

Graduate School in Humanities  
 University of Cape Town  
 Rondebosch 7700  
 South Africa  
 Lass@iafrica.com

## References

- Benediktsson, H. (ed.) (1972). *The first grammatical treatise*. University of Iceland Publications in Linguistics 1. Reykjavík: Institute of Nordic Linguistics.
- Benskin, M. (1997). Texts from an English township in late mediaeval Ireland. *Collegium Mediaevale* 10: 91–173.
- Benskin, M. (2001). The language of the English texts. In Hunt, T. & M. Benskin (eds.), *Three Receptaria from medieval England*. Medium Ævum Monographs, NS 21. Oxford: Society for the Study of Medieval Languages and Literature. Chapter 4, 193–230.
- Benskin, M. (in preparation). On the ignorance of Anglo-Norman scribes.
- Black, M. (1999). AB or simply A? Reconsidering the case for a standard. *Neuphilologische Mitteilungen* 100: 155–74.
- Britton, D. (1994). The etymology of modern dialect 'en, 'him'. *Notes and Queries* 239: 16–18.
- Brown, C. (1924). *English lyrics of the XIIIth century*. Oxford: Clarendon Press.
- Clark, C. (1992). The myth of 'the Anglo-Norman scribe'. In Rissanen, M., O. Ihalainen, T. Nevalainen & I. Taavitsainen (eds.), *History of Englishes: new methods and interpretations in historical linguistics*. Topics in English Linguistics 10. Berlin and New York: Mouton de Gruyter. 117–29.
- d'Ardenne, S. R. T. O. (ed.) (1961). *Je liflade ant te passiuin of Seint Iulienne*. EETS os 248. London, New York, Toronto: Oxford University Press.
- d'Ardenne, S. R. T. O. & E. J. Dobson (eds.) (1981). *Seinte Katerine*. EETS ss 7. London, Glasgow, New York, Toronto: Oxford University Press.
- Haugen, E. (1950). First grammatical treatise: the earliest Germanic phonology. An edition, translation and commentary. Language Monograph no. 25 (supplement to *Language* 26: 4).
- Laing, M. (1999). Confusion *wrs* confounded: litteral substitution sets in early Middle English writing systems. *Neuphilologische Mitteilungen* 100: 251–70.
- Laing, M. (2000). 'Never the twain shall meet'. Early Middle English – the east-west divide. In Taavitsainen, I., T. Nevalainen, P. Pahta & M. Rissanen (eds.), *Placing Middle English in context*. Topics in English Linguistics 35. Berlin and New York: Mouton de Gruyter. 97–124.
- LALME* = McIntosh et al. (1986).
- Lass, R. (1997). *Historical linguistics and language change*. Cambridge: Cambridge University Press.
- Lass, R. (1999). Phonology and Morphology. In Lass, R. (ed.), *Cambridge history of the English language, vol. III 1476–1776*. Cambridge: Cambridge University Press. 56–186.
- Lass, R. & M. Laing (forthcoming). Are front rounded vowels retained in West Midland Middle English? Paper delivered at the 4th International Conference on Middle English, Vienna 2002.
- McIntosh, A., M. L. Samuels & M. Benskin (1986). *A linguistic atlas of late Mediaeval English*, 4 vols. Aberdeen: Aberdeen University Press.
- Mack, F. M. (ed.) (1934). *Seinte Marherete*. EETS os 193. London: Oxford University Press.
- Millett, B. (ed.) (1982). *Hali Meiðhad*. EETS os 284. London, Glasgow, New York, Toronto, etc.: Oxford University Press.
- Pope, M. K. (1934). *From Latin to Modern French with especial consideration of Anglo-Norman*. Manchester: Manchester University Press (2nd edition 1952).

- Potts, J., L. Stevenson & J. Wogan-Browne (eds.) (1993). *Concordance to Ancrêne Wisse*. Cambridge: D. S. Brewer.
- Reichl, K. (ed.) (1973). *Religiöse Dichtung im englischen Hochmittelalter*. Münchener Universitäts-Schriften, vol. 1. Munich: Wilhelm Fink Verlag.
- Smith, J. (2000). Standard language in early Middle English. In Rissanen, M., O. Ihalainen, T. Nevalainen & I. Taavitsainen (eds.), *History of Englishes: new methods and interpretations in historical linguistics*. Topics in English Linguistics 10. Berlin and New York: Mouton de Gruyter. 125–39.
- Tolkien, J. R. R. (ed.) (1962). *Ancrêne Wisse*. EETS os 249. London, New York, Toronto: Oxford University Press.
- Wallis, J. (1653). *Ioannis Wallisii Grammatica Lingvae Anglicanae. Cui praefigitur, de loqvela; sive de sonorum omnium loquelarium formatione: tractatus grammatico-physicus*. London: William Bower. Also in Kemp, J. A. (1972). *John Wallis's grammar of the English language*. London: Longman.
- Williamson, K. (2000). Changing spaces: linguistic relationships and the dialect continuum. In Taavitsainen, I., T. Nevalainen, P. Pahta & M. Rissanen (eds.), *Placing Middle English in context*. Topics in English Linguistics 35. Berlin and New York: Mouton de Gruyter. 141–80.
- Wilson, R. M. (ed.) (1938). *Sawles warde*. Leeds School of English Texts and Monographs 3.
- Zoëga, G. T. (1910). *A concise dictionary of Old Icelandic*. Oxford: Clarendon Press.

#### Appendix 1

*Lexical Corpus*. Spellings for BRIGHT, MIGHT sb. and vb. pret., NIGHT and WIGHT in the writing systems of scribes originating from areas neighbouring that of Cambridge, Trinity College 323, Scribe A, including a full inventory of his own spellings for these words. Note that the material is in LAEME internal format: \$ indicates the beginning of a lemma, / separates lexical from grammatical information. {rh} indicates the form appears in rhyming position. Manuscript forms are in upper case. Lower-case letters indicate abbreviations or ‘special’ letters: ae = ‘æsc’, y = ‘thorn’, w = ‘wynn’, z = ‘yogh’, d = ‘edh’. ^I indicates that in the manuscript the <i> is superscript.

*London, British Library, Cotton Caligula A.ix: Laȝamon A, Scribe A*

BRIGHT – not represented in sample

\$might/n<pr MIHTEN 1

\$might/npl<pr MIHTEn 1

\$mighty/aj MaeHTI 1

\$may/vpt13 MIHTE 16 MAHTE 2

\$may/vpt23{rh} MIHTEN 1 MIHTEn 1

\$may/vsjpt11 MIHTE 1

\$may/vsjpt13 MAHTE 2 MIHTE 1

\$night/n NIHT 1

\$night/n-av-k +NIHT 1 NIHTE 1

\$night/n<pr NIHTE 2



\$night/n<pr-k -NIHT 1  
 \$night/n<pr{rh} NIHTE 2 NITH 1  
 \$night/npl-av NIHT 2  
 \$night/npl-av{rh} NIHT 1

WIGHT – not represented in sample

*London, British Library, Cotton Caligula A ix: Lazamon A, Scribe B*

BRIGHT – not represented in sample

\$might/n<pr MIHTEN 1  
 \$might/npl MaeHTE 1  
 \$mighty/aj MIHTI 1  
 \$may/vpt11 MIHTE 1  
 \$may/vpt13 MIHTE 7 MIHTEN 1 MIHTEn 1  
 \$may/vpt13{rh} MIHTE 1 MaeHTE 1  
 \$may/vpt23 MIHTEN 5  
 \$may/vsjpt13 MIHTE 3 MOHTE 1

\$night/n-av-k +NIHT 1  
 \$night/n-av-k{rh} -NIHTE 3  
 \$night/n-av{rh} NIHT 1  
 \$night/n-k{rh} -NIHT 1  
 \$night/n<pr NIHT 1 NIHTE 1  
 \$night/n<pr-k{rh} -NIHT 1  
 \$night/n<pr{rh} NIHT 1  
 \$night/nG-av NIHTES 3  
 \$night/npl-av{rh} NIHTES 1 NIzT 1  
 \$night/npl<pr{rh} NIHTTES 1  
 \$night/nplG NIHTE 1

WIGHT – not represented in sample

*Cambridge, Trinity College 323, Scribe A*

\$bright/aj BRIT 1  
 \$bright/aj<pr BRISTE 1 B^IT 1  
 \$bright/aj<pr{rh} BRISTE 1 BRIT 1  
 \$bright/ajpl{rh} BRISTE 1  
 \$bright/aj{rh} BRISTE 3 BRIT 3 BRIST 2  
 \$bright/av BRISTE 1 BRITHE 1

\$might/n<pr{rh} MISTE 2 +MIST 1  
 \$might/nOd{rh} MIST 1  
 \$might/npl<pr MISTEN 1

\$might/npl<pr{rh} MISTEN 1  
 \$might/n{rh} MISTE 2 MITHTHE 1

\$may/vpt13 MISTE 1  
 \$may/vpt13{rh} MISTE 1  
 \$may/vpt21 MISTEN 1  
 \$may/vpt23 MISTEN 1  
 \$may/vsjpt13 MISTE 1

\$night/n-av{rh} NICST 1 NICT 1  
 \$night/n<pr-k{rh} +NIST 1 -NIST 1  
 \$night/n<pr{rh} +NISTE 2 NICSTE 1 NIST 1

\$wight/n VIIT 1  
 \$wight/n<pr{rh} VISTE 1  
 \$wight/nOd{rh} VICHIT 1  
 \$wight/n{rh} WIST 2

*Cambridge, Trinity College 323, Scribe D*

\$bright/aj BRIT 2  
 \$bright/aj{rh} BRIT 1  
 \$might/nOd MISTE 1  
 \$might/npl<pr{rh} MISTEN 1  
 \$may/vps12 MIST 5 MAIST 3  
 \$may/vps12{rh} MIT 1  
 \$may/vpt12 MESTES 1 MITHT 1  
 \$may/vpt13 MIST 1  
 \$may/vsjpt13 MICHTE 1  
 \$may/vsjpt22 MISTIN 1  
 \$night/nOd{rh} NITF 1  
 \$wight/nOd wIDT 1  
 \$wight/nOi wID 1

*Worcester Cathedral, Dean and Chapter Library F 174: Worcester Tremulous Hand*

\$bright/aj BRIHT 1  
 \$bright/av BRIHTE 1  
 \$brightly/av BRIHTLICHE 1  
 \$brightness/n BRIHTNESSE 1  
 \$might/n MIHT 7  
 \$might/nG \*MIHTE 1  
 \$might/nOd MIHTE 3

\$mighty/aj VNMIHTI 2 MIHTI 1

\$may/vpt11 MIHTE 2

\$may/vpt12 MIHTES[T] 1

\$may/vpt13 MIHTE 1

\$may/vpt21 MUHTEN 1

\$may/vpt23 MIHTEN 3

\$night/n NIHT 1

\$night/n<pr NIHT 1

\$night/nplG NIHTA 2

\$wight/nplOd wIHTE 1

*Oxford, Bodleian Library, Digby 86*

\$bright/aj BRIZT 2

\$bright/aj-cpv \*BRIZTTERE 1

\$bright/aj<pr BRIZTTE 1

\$bright/ajOd{rh} BRIZTTE 2

\$bright/ajpl BRIZT 2

\$bright/ajpl-cpv BRIZTTORE 1

\$bright/ajpl<pr{rh} BRIZT 1

\$bright/ajpl{rh} BRIZT 1 BRIZTE 1 BRIZTTE 1

\$bright/aj{rh} BRIZT 8 BRIZTT 1

\$bright/av{rh} BRIZTTE 1

\$might/n MIZTE 1 MIZTTE 1

\$might/n<pr MIZTE 2 MIZTTE 1

\$might/n<pr{rh} MIZTTE 6 MIZT 2

\$might/nOd MIZT 1 MIZTTE 1

\$might/nOd{rh} MIZTTE 1

\$might/n{rh} MIZTTE 2 MIZT 1 MIZT 1

\$may/vpt11 MIZT 1

\$may/vpt12 MIZTEST 1

\$may/vpt13 MIZTTE 5 MIZTE 3

\$may/vpt13{rh} MIZTTE 2 MIZTE 1

\$may/vpt21{rh} MIZTTE 1

\$may/vpt22 MIZTTEN 1

\$may/vpt23 MIZTE 1 MIZTEN 1 MIZTTE 1 MIZTTEN 1 MIZTTEn 1

\$may/vsjpt11 MIZTE 1 MIZTTE 1

\$may/vsjpt13 \*MIZTTE 1 MIZTE 1

\$may/vsjpt13{rh} MIZTTE 1

\$may/vsjpt21{rh} MIZTTE 1

\$may/vsjpt22{rh} MIZTTE 1

\$may/vsjpt23{rh} MIzTE 1

\$night/n-av NIzT 5

\$night/n-av-k{rh} +NIzTTE 1

\$night/n-av{rh} NIzT 2

\$night/n<pr NIzTE 1

\$night/n<pr-k{rh} -NIzTTE 1

\$night/n<pr{rh} NIzTTE 6 NIzTT 2 NIzT 1 NIzTE 1

\$night/nOd{rh} NIzTTE 1

\$night/n{rh} NIzT 2

\$nightingale/n \*NIzTTINGALE 3 NIzTINGALE 2 \*NIzTINGALE 1

\$nightingale/n<pr{rh} NIzTTEGALE 1

\$nightingale/n{rh} NIzTTINGALE 1

\$wight/n<pr{rh} ONWizTTE 1 WizTTE 1

\$wight/nOd{rh} WizTT 1

\$wight/n{rh} WizT 1

*London, British Library, Cotton Otho C xiii: Lazamon B*

BRIGHT – not represented in sample

\$might/n MIHTE 1

\$might/n<pr MIHTE 2 MIyTE 1

\$might/n<pr{rh} MIHT 1

\$might/nOd MIHTE 3

\$might/npl MIHTES 1

\$mighty/aj MIHTI 1 MIyTI 1

\$may/vpt11 MIyTE 1

\$may/vpt12 MIyT 1

\$may/vpt13 MIHTE 13 MIyTE 2 MIyT 1

\$may/vpt23 MIHTE 2

\$may/vpt23{rh} MIyTE 1

\$may/vsjpt13 MIHTE 1

\$night/n-av-k +NIyT 1 +NIyTE 1

\$night/n<pr NIyTE 1

\$night/n<pr-k +NIyT 1

\$night/n<pr{rh} NIyT 1

\$night/npl-av NIyT 2

\$night/npl-av{rh} NIyTES 3 NIyT 2

\$night/n{rh} NIyTE 1

WIGHT – not represented in sample

## Appendix 2

'Itemlist' showing EME syllable rhyme spellings by MS source, conflated for RIGHT, BRIGHT, DRYHT(EN), KNIGHT, LIGHT (< *lēoht*), LIGHT (< *liht(-)*), MIGHT n., NIGHT, WIGHT, WIHT (= 'strong'), DIHTAN, LIGHTS (= 'lungs'), PLIGHT, STIHTAN, WEIGHT (< *(ge)wiht*). Leading hyphens indicate any syllable onset from the above list. + indicates following inflections or derivational markers. Numbers on the left-hand side indicate index numbers for the texts for which the key is provided below.

Brackets indicate proportions of citations:

unbracketed = > .5;

single brackets = ≤ .5, > .2;

double brackets = > 0, ≤ .2.

- 2 -IzT+ (-IzT) ((-IzTT+))  
 3 (-IHT+ -IHT -IzT+) ((-IzT -EHT+))  
 5 -IHT+ ((-ICHT+ -IHT))  
 6 -IHT+ ((-IHT))  
 7 -IHT+ ((-IHT -ITHT+ -ITT+ -IT+))  
 170 (-ICT+) ((-ICCH -ICCHT+ -ICH+ -ICHT+ -ICTH -ITH+ -<sup>^</sup>ICCH))  
 189 -IHT+ (-IHT)  
 245 -IHT+ (-IHT)  
 246 (-IST+ -IST) ((-IT -IS+ -ICST -ICHIT -ICST+ -ICT -IIT -IT+ -ITH+ -ITHTH+  
 -<sup>^</sup>IT))  
 247 (-IST -IST+) ((-ITT+ -YTT+))  
 248 -IT -ITT-  
 249 (-IST+) ((-IT -ICH+ -ID -ICHT -ICT -ICT+ -IDT -IIT -IT+ -ITF -ITH -ITHT-  
 ITT+ -IzT+))  
 260 -IHT+ (-IHT) ((-IH))  
 261 -IHT+ (-IHT)  
 262 -IHT+ (-IHT) ((-IHdT-))  
 272 -IHT+ (-IHT)  
 273 (-ICHT+ -ICHT) ((-<sup>^</sup>ICHT -IHT+ -<sup>^</sup>ICHT+ -ICH+ -IHCT+ -<sup>^</sup>ICH))  
 275 -IHT+ (-IHT)  
 276 (-ICHT+ -ICHT) ((-IHT+ -ICH+ -IHT -INCHT -ICH -ICHIT -IyT+))  
 277 -IHT+ (-IHT) ((-IT+ -IH+ -IT -ITH))  
 278 (-IHT+ -IHT) ((-INH+ -IH+ -IHHT+ -ICT+ -INHDT+ -IRH+ -ITH -InCT  
 + -IzT))  
 1000 -IHT+ (-IHT)  
 1100 (-IHT+ -YHT+ -IHT) ((-YHT -YH+))  
 1800 -IHT+ (-IHT) ((-ITH+ -IHHT+ -IT+ -ITH -ITHT))  
 1900 -IHT+ (-IHT) ((-IHHT+))  
 2000 -IHT+ ((-IHT -EHT+ -IH+))

2001 -IHT+ ((-IHT -ICHT -ICHT+ -ICT+ -INCHT+))

2002 (-IzT -IzTT+) ((-IzT+ -IzTT -IzT -IST+ -IT))

### Appendix 3

Provisional schematization of the material from appendix 2 for mapping (see map 2). <i>-superscript has been conflated with <i>. The forms in column 2 represent our informed guesses as to the import of the various spellings (see map 3). The forms in the right-hand column represent poorly resolved broad phonetic transcriptions. They are *not* intended to represent ‘-emic’ entities of any kind. This is not a matter of theoretical queasiness, but a function of the fact that the texts do not supply sufficient information to make judgments about distinctiveness. None of the systems we deal with allows complete sets of ‘grapheme-to-phoneme’ mappings.

Orthographical realizations	Phonological possibilities
2 IzT IzTT	2 ixt
3 IHT IzT EHT	3 ixt, ext
5 ICHT IHT	5 ixt
6 IHT	6 ixt
7 IHT ITHT ITT IT	7 ixt, iθt, it:, i:t
170 ICT ICCH ICCHT ICH ICHT ICTH ITH	170 ix(t), i(x)θ
189 IHT	189 ixt
245 IHT	245 ixt
246 IST IT IS ICST ICHIT ICT IIT ITH ITHTH	246 ix(t), i:t, iθ
247 IST ITT YTT	247 ixt, it:
248 IT ITT	248 i:t, it:
249 IST IT ICH ID ICHT ICT IDT IIT ITF ITH ITHT ITT IzT	249 ix(t), i:t, it:, iθ(t)
260 IHT IH	260 ix(t)
261 IHT	261 ixt
262 IHT IHdT	262 ixt, ixθ?
272 IHT	272 ixt
273 ICHT IHT ICH IHCT	273 ix(t)
275 IHT	275 ixt
276 ICHT IHT ICH INCHT ICHIT IyT	276 ix(t), iθt
277 IHT IT IH ITH	277 ix(t), i:t, iθ
278 IHT INHT IH IHTT ICT INHDT IRH ITH InCT IzT	278 ix(t), iθ
1000 IHT	1000 ixt
1100 IHT YHT IHT YH	1100 ix(t)
1800 IHT ITH IHTT IT ITHT	1800 ixt, iθ(t), i:t

1900 IHT IHTT	1900	ixt
2000 IHT EHT IH	2000	ix(t), ext
2001 IHT ICHT ICT INCHT	2001	ixt
2002 IzT IzTT IlzT IST IT	2002	ixt, i:t, i:xt?

## Key to appendices 2 and 3

- 2 BL Cotton Caligula A ix, fols. 233r–239v l 13; 240r l 6–241v l 15: *The Owl and the Nightingale*, language 1.
- 3 BL Cotton Caligula A ix, fols. 239v l 14–240r l 5; 241v l 16–246r: *The Owl and the Nightingale*, language 2.
- 5 London, Lambeth Palace Library 487, fols. 59v–65r: *Poema Morale*.
- 6 London, British Library, Egerton 613, fols. 64r–70v (e): *Poema Morale*.
- 7 London, British Library, Egerton 613, fols. 7r–12v (E): *Poema Morale*.
- 170 Worcester Cathedral, Dean and Chapter Library Q 29, fols. 130v–131r.
- 189 Lambeth Palace Library 487, fols. 65v–67r hand B: *On Ureison of Ure Loverde*.
- 245 London, British Library, Cotton Nero A xiv, sample of parts 1–2, fols. 1r–29r, hand A: *Ancrene Riwe*.
- 246 Cambridge, Trinity College B.14.39 (323), fols. 19r, 25v, 27r col 2, 28r–29v, 32r–33v, 36r–46r, 47r–v, 83v–84r, hand A: verses.
- 247 Cambridge, Trinity College B.14.39 (323), fols. 20r–25r, 26r–27r col 1, 27v, 34r, 35r–v, hand B: verses.
- 248 Cambridge, Trinity College B.14.39 (323), fols. 30r–31v, 81v, hand C: verses.
- 249 Cambridge Trinity College B.14.39 (323), fols. 81v–82r, 85r–87v, hand D: verses.
- 260 London, British Library, Royal 17.A.xxvii, fols. 1r–8v, 11r–37r (end of *St K*), hand A: *Sawles Warde*, *St Katherine* and part of *St Margaret*.
- 261 London, British Library, Royal 17.A.xxvii, fols. 9r–10v, 58v–70v, hand B: end of *Sawles Warde*, most of *St Juliana*, *Oreisun of Seinte Marie*.
- 262 London, British Library, Royal 17.A.xxvii, fols. 45v–58r, hand C: part of *St Margaret*, beg. of *St Juliana*.
- 272 Cambridge, Corpus Christi College 402, sample of parts 1–2, fols. 1r–32r: *Ancrene Wisse*.
- 273 London, British Library, Cotton Cleopatra C.vi, sample of parts 1–2, fols. 4r–48r, hand A: *Ancrene Riwe*.
- 275 London, British Library, Cotton Cleopatra C vi, corrections to text of *Ancrene Riwe* in hand B.
- 276 Cambridge, Gonville and Caius College 234/120, sample of pp. 1–59: extracts from *Ancrene Riwe*.
- 277 London, British Library, Cotton Caligula A.ix, fols. 3r–17rb (foot); 17va line 5–18vb line 6; 27ra lines 1–6 (bliþe); 88ra–89rb line 3, hand A: Laḡamon A.
- 278 London, British Library, Cotton Caligula A.ix, fols. 17va lines 1–4; 18vb line 7–26vb (foot); 27ra line 6 (þat)–87vb (foot), 89rb line 4–194v (end), hand B: Laḡamon A – tagged to fol. 35va, line 3000.

- 1000 Bodleian Library, Bodley 34, fols. 52r–80v: *Hali Meiðhad*, *Sawles Warde*.
- 1100 Oxford, Jesus College 29, fols. 156r–174v, 179v–185v, 187r–188v: verses incl. *Owl and the Nightingale*, *Poema Morale*, Thomas Hale's *A Luue Ron*.
- 1800 Hand B of Cotton Nero A xiv, fols. 120v–131v: The Wooing Group.
- 1900 Worcester Tremulous Hand: i.e. Oxford, Bodleian Library, Junius 121, fol. vi: Nicene Creed and Worcester Cathedral, Dean and Chapter Library F 174, fols. 1r–66v: Worcester fragments, Ælfric's Grammar and Glossary.
- 2000 Lambeth Homilies, fols. 1r–21v, 30v–51v, hand A lang 1.
- 2001 Lambeth Homilies, fols. 21v–30v, 51v–64r, hand A lang 2.
- 2002 Bodleian Library, Digby 86, fols. 119r–206r (excluding *XI Pains of Hell*, *Proverbs of Hending*, *Dame Sirith*, *Debate between the Body and the Soul* (in mixed language)).