



THE UNIVERSITY *of* EDINBURGH

Edinburgh Research Explorer

Fibre Reinforced Cementitious Matrix Systems for Fire-Safe Flexural Strengthening of Concrete: Pilot Testing at Ambient Temperatures

Citation for published version:

Bisby, LA, Stratford, TJ, Roy, EC & Ward, M 2009, 'Fibre Reinforced Cementitious Matrix Systems for Fire-Safe Flexural Strengthening of Concrete: Pilot Testing at Ambient Temperatures'. in *Advanced Composites in Construction (ACIC) 2009 Conference Proceedings*. NetComposites Ltd., pp. 449-460.

Link:

[Link to publication record in Edinburgh Research Explorer](#)

Document Version:

Author final version (often known as postprint)

Published In:

Advanced Composites in Construction (ACIC) 2009 Conference Proceedings

General rights

Copyright for the publications made accessible via the Edinburgh Research Explorer is retained by the author(s) and / or other copyright owners and it is a condition of accessing these publications that users recognise and abide by the legal requirements associated with these rights.

Take down policy

The University of Edinburgh has made every reasonable effort to ensure that Edinburgh Research Explorer content complies with UK legislation. If you believe that the public display of this file breaches copyright please contact openaccess@ed.ac.uk providing details, and we will remove access to the work immediately and investigate your claim.



Fibre Reinforced Cementitious Matrix Systems for Fire-Safe Flexural Strengthening of Concrete: Pilot Testing at Ambient Temperature

Dr LA Bisby, EC Roy, M Ward & Dr TJ Stratford
Institute for Infrastructure and Environment, University of Edinburgh
King's Buildings, Mayfield Road, Edinburgh, Scotland, UK EH9 3JL

ABSTRACT

Textile reinforced mortar (TRM) systems have emerged in the last five years as novel means of strengthening damaged or deficient masonry or concrete structural members. These systems typically consist of open-weave carbon fibre fabrics which are applied to the surfaces of structural elements, walls, domes, or shells using specialized inorganic mortars. More recently, fibre reinforced cementitious matrix (FRCM) systems based on non-woven polybenzoxazole (PBO) fibre rovings have also been introduced. TRM and FRCM systems have a number of advantages over alternative strengthening systems such as externally-bonded (EB) fibre reinforced polymers (FRPs), most notably their breathability and purported superior performance in fire. However, while TRM and FRCM systems have seen limited application in Europe, additional research is needed before they can be widely applied with confidence, both with respect to their performance under ambient conditions and regarding their ability to resist the effects of exposure to high temperature. This paper reports the initial results of a pilot experimental study into the performance at ambient temperature of a unique FRCM system for strengthening reinforced concrete flexural elements. Tests on small-scale reinforced concrete beams (designed to simulate one-way spanning concrete slabs) are presented. A comparison of the FRCM system against an EB carbon/epoxy FRP strengthening system is provided.

INTRODUCTION

In recent years, textile reinforced mortar (TRM) systems have emerged as novel means of strengthening damaged or deficient masonry or reinforced concrete (RC) structures [1]. These systems consist of open-weave fibre fabrics which are applied to the surfaces of structural elements using specialized inorganic mortars. Until recently the open-weave fabrics for these systems normally consisted of carbon fibres, which led to comparatively poor utilization of the fibres due to fibre pullout at relatively low load levels. Fibre reinforced cementitious matrix (FRCM) systems based on non-woven polybenzoxazole (PBO) fibre rovings have also been introduced [2]. The unique chemical structure of the PBO fibres allows them to bond directly to cementitious mortar matrices, thus eliminating the need for an epoxy resin to bond the fibres to an inorganic substrate [2]. These PBO-based FRCM systems have several advantages over alternative systems such as externally-bonded (EB) fibre reinforced polymer (FRP) systems, most notably their breathability and superior performance in fire (in particular their non-combustibility). However, while these systems have been applied in several projects in Europe, research on both their ambient and high temperature performance in flexural strengthening applications is needed before they can be applied widely with confidence.

Strengthening RC or masonry structures with EB FRPs is now widely recognized for its effectiveness and ease of application [3]. FRP sheets or plates can be bonded to the exterior faces of RC members or masonry walls using ambient-cure epoxy adhesives. In these applications (and also in TRM and FRCM strengthening applications) the goal is to provide well-anchored supplementary tensile reinforcement to a concrete or masonry substrate. Either EB FRP, TRM, or FRCM techniques can be used to provide shear or flexural strengthening for RC or masonry members [1,2], or for confinement of RC columns [4].

A key issue in the design of any structural strengthening system for use in buildings is its mechanical and thermal performance during fire. Fire-rated, insulated EB FRP strengthening systems have been tested and are now available for use [5], although current design guidelines rightly suggest that the structural effectiveness of FRP strengthening systems should be ignored during fire [6], unless it can be shown that they would remain effective at the temperatures expected during fire. Hence, applications of FRPs for strengthening concrete buildings, parking garages, and certain industrial structures are often hindered by a lack of knowledge regarding the ability of FRP systems to maintain structural effectiveness under service loads at high temperature.

It has been suggested [2] that TRM and FRCM systems may outperform FRP systems during fire due to their inherent non-combustibility, and possibly to superior strength retention at elevated temperatures. Preliminary studies on the performance of specific FRCM systems under sustained loads and exposure to temperatures up to 120°C have shown that TRM systems outperform FRP strengthening systems under these conditions [7]. However, no research has yet been reported on the comparative performance of FRCM and FRP systems under short-term exposure to higher temperatures, as might reasonably be experienced during a fire. This paper presents the results of initial pilot testing conducted at ambient temperatures to verify the performance of a specific FRCM system in flexural strengthening applications for RC. On the basis of the positive results presented herein, additional testing is currently underway to study the performance of this system at elevated temperatures of more than 200°C.

It is important to note that a key advantage of both TRM and FRCM systems in fire is their inherent non-combustibility [8]. Previous research on FRP strengthening systems in fire has shown that loss of the strengthening systems' mechanical performance during fire may not be critical provided that reasonable strengthening limits are imposed during design of the strengthening system [6]. However, structural performance in fire is only one of a host of concerns that must be addressed when considering application of any structural material in a building. Fire severity, flame spread, and smoke generation and toxicity cannot be ignored since they are critical to preserving tenable conditions in the early stages of a fire and to allow safe evacuation of a building's occupants. Unprotected EB FRP strengthening systems, which incorporate polymer adhesives/matrices, will burn vigorously if directly exposed to fire, will contribute fuel, increase flame spread, and generate toxic smoke. FRP strengthening systems therefore require protection by fire-rated flame spread coatings in all interior applications in buildings to meet life-safety objectives. TRM and FRCM systems bonded with inorganic mortars are inherently non-combustible and can therefore be used unprotected; reducing their material and installation costs and improving their aesthetics.

OBJECTIVE

The objective of the current study was to experimentally investigate the relative performance of EB FRP and FRCM flexural strengthening systems for RC structures (in bond-critical applications without supplemental anchorage); and to provide baseline data for future testing at elevated temperatures to investigate the concept that PBO-based FRCM systems may provide superior retention of mechanical properties at high temperature as compared with EB FRP systems.

EXPERIMENTAL PROGRAM

Research on the high temperature performance of both EB and near surface mounted (NSM) FRP strengthening systems has been presented previously [3]. Prior research has shown that both EB and NSM FRP strengthening systems, which typically rely on a polymer adhesive/matrix (in bond-critical situations) are sensitive to exposure to temperatures below 100°C in flexural strengthening applications when stressed to between 30% and 60% of their ultimate strength during heating [3]. Heating to 200°C under sustained load resulted in rapid failure of both EB and NSM carbon FRP strengthening systems (either using epoxy or cementitious adhesives).

The tests performed for the current study were designed to be as similar as possible to those used in previous testing [3] so that the results on the FRCM system could be compared against results for both EB and NSM FRP systems.

Details of the experimental program for the current study are given in Table 1. Twelve RC beam specimens intended to represent thin strips of a one-way RC slab were cast. Four of these were strengthened in bending with a single layer of a commercially available EB carbon/epoxy unidirectional FRP fabric strengthening system, six beams were strengthened using a commercially available PBO fibre fabric FRCM strengthening system, and two beams were left unstrengthened and used as control specimens to define the level of strengthening that was achieved for each of the respective strengthening systems. This paper reports results only from the initial tests on six beams at ambient temperature. All ambient temperature tests were performed under monotonic load to failure. High temperature tests, which are currently underway, are being performed under sustained load with increasing temperature to failure. Tables 1 and 2 provide an overview of the specific specimens, materials and systems, loading regimes, and parameters that are being varied during the experimental program.

Beam specimens

The dimensions and reinforcement details of the RC beam specimens are provided in Figure 1. They were designed to simulate strips of scaled-down one-way RC slabs with deficient internal steel reinforcement such as might require strengthening in bending. The beams' internal reinforcement was chosen such that crushing of the concrete and shear failure of the EB FRP strengthened specimens was expected to be avoided prior to the FRP

strengthening system reaching strain levels close to or exceeding those sufficient to cause bond failure (according to ACI 440.2R-08 [6], but ignoring the currently imposed strengthening limits). The resulting beams were very lightly reinforced internally, with a steel reinforcement ratio of only 0.30%. The compressive strength of the concrete at the time of testing was 29.8 MPa with a standard deviation of ± 0.5 MPa at 20°C, as determined from three uniaxial compression tests on standard 150 mm diameter by 300 mm tall concrete cylinders. The internal steel reinforcement in the beams consisted of two 7 mm diameter deformed steel bars with a nominal yield strength of 500 MPa (based on information provided by the reinforcement supplier). All beams had a small (25.4 mm wide \times 25.4 mm deep) notch at midspan to act as a crack initiator within the beams' constant moment region during testing (see below).

Table 1. Details of experimental program

Specimen ID	Strengthening system	Target test temperature (°C) ¹	Loading regime	Number of specimens
RC 20	--	20	2kN/min to failure	2
FRP 20	FRP	20	2kN/min to failure	2
FRCM 20	TRM	20	2kN/min to failure	2
FRP 100	FRP	100	20kN sustained load ²	1
FRCM 100	TRM	100	20kN sustained load ²	2
FRP 200	FRP	200	20kN sustained load ²	1
FRCM 200	TRM	200	20kN sustained load ²	2

¹ Refer to Figure 5

² If no failure is observed after 240 minutes of heating, the load will be increased at 2 kN/min until failure

Note: Tests appearing in shaded cells are currently underway and not presented herein

Strengthening systems

Two beams were left unstrengthened as control specimens and the remaining beams were strengthened with either an EB FRP or FRCM strengthening system. Surface preparation consisted of light grinding by hand followed by high pressure water blasting. Table 2 provides details of the two specific strengthening systems used, both of which are proprietary, commercially available systems.

Externally-Bonded Carbon FRP System

As shown in Table 1 and Figure 1, four beams were strengthened with a single layer of an EB carbon/epoxy FRP fabric strengthening system using an epoxy adhesive. The width of the EB sheet (235 mm) was chosen based on previous studies comparing EB and NSM FRP systems at high temperature [3]. The system was applied using a wet lay-up procedure at ambient conditions (i.e. no post cure) according to the supplier's recommended procedures.

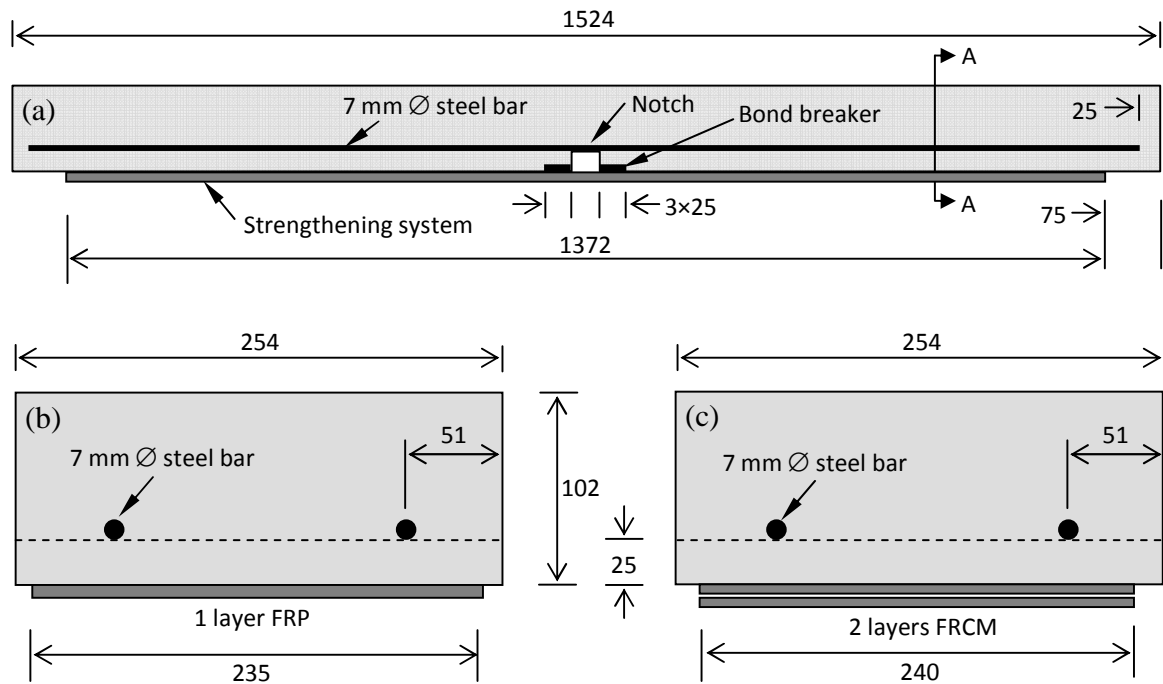

Figure 1. Schematics showing (a) elevation view of details of flexural test specimens and Section A-A views for (b) FRP strengthened and (c) FRCM strengthened specimens (all dimensions are in mm)

Table 2. Strengthening systems used

Name	Method	Reinforcement	Adhesive	Strength ⁵ (N/mm)	Stiffness ⁵ (kN/mm)	Failure strain (%) ⁵
FRP	Externally bonded	Unidirectional carbon fabric ¹	Epoxy ³	331	24.9	1.33
FRCM	Externally bonded	Bi-directional open grid PBO ²	Cement mortar ⁴	264	12.3	2.15

¹ Sika Corp., Sikawrap Hex 230C carbon fabric (www.sikaconstruction.com)

² Ruredil, X Mesh Gold fabric (www.ruredil.it)

³ Sikadur 330 epoxy (www.sikaconstruction.com)

⁴ Rurecem X Mesh M750 mortar (www.ruredil.it)

⁵ Manufacturer-specified average properties are given per unit width of a single layer in the warp direction

Fibre Reinforced Cementitious Matrix System

As shown in Table 1 and Figures 1 and 2, six beams were strengthened with a commercially available PBO/inorganic mortar FRCM strengthening system. The amount of FRCM fabric used to strengthen the beams (a width of 240 mm with two layers on each

beam) was chosen to provide the equivalent axial stiffness of the FRP strengthening system, so as to achieve similar flexural stiffness as the FRP strengthened beams. It should be noted that the equivalent tensile strength of the FRCM strengthening was therefore about 60% higher than the FRP system. The FRCM was installed using the following procedure (refer to Figures 2a and 2b):

1. Once surface preparation was completed as described previously, the beam's surface was moistened with water to achieve a saturated-surface-dry (SSD) condition.
2. A thin layer of inorganic mortar, approximately 4 mm thick, was applied to the beam's soffit (note that the beams were strengthened upside-down for ease of application).
3. One layer of open-weave PBO fabric (shown in Figure 2a) was placed on the beam's soffit and gently pressed into the inorganic mortar.
4. A second 4 mm layer of mortar was applied to the surface of the beam.
5. A second layer of PBO mesh was gently pressed into the mortar.
6. A final topcoat of mortar, again approximately 4 mm thick, was applied to the surface of the beam.
7. The strengthened beams were allowed to cure under plastic sheets at approximately 20°C for 48 hours before being stored in the laboratory under ambient conditions until testing (approximately 28 to 42 days later).



Figure 2. (a) Open-weave PBO fibre fabric and (b) installation of the first layer of the FRCM system on one of the beams

Test Setup, Instrumentation, and Procedures

All beams were tested upside-down in four-point bending as shown in Figure 3. This approach was taken to facilitate heating of the strengthening systems during future testing (as described on the basis of previous research in Reference [3]). Conventional instrumentation was used to collect load (load cell), vertical displacement (linear potentiometers), and temperature (thermocouples) data at various locations during testing (refer to Figure 3). In addition, a sophisticated digital imaging analysis technique (geoPIV), based on pixel-tracking in high-resolution digital images, is being used to monitor the

cross-sectional flexural strain distributions at midspan [9]. Details of the geoPIV analysis technique are provided below.

A total of six beams were tested at ambient temperature to determine the level of strengthening achieved, the strengthening system strain at failure, the failure mode (s), and to verify the ability of the members to withstand the sustained load to be used for high temperature testing.

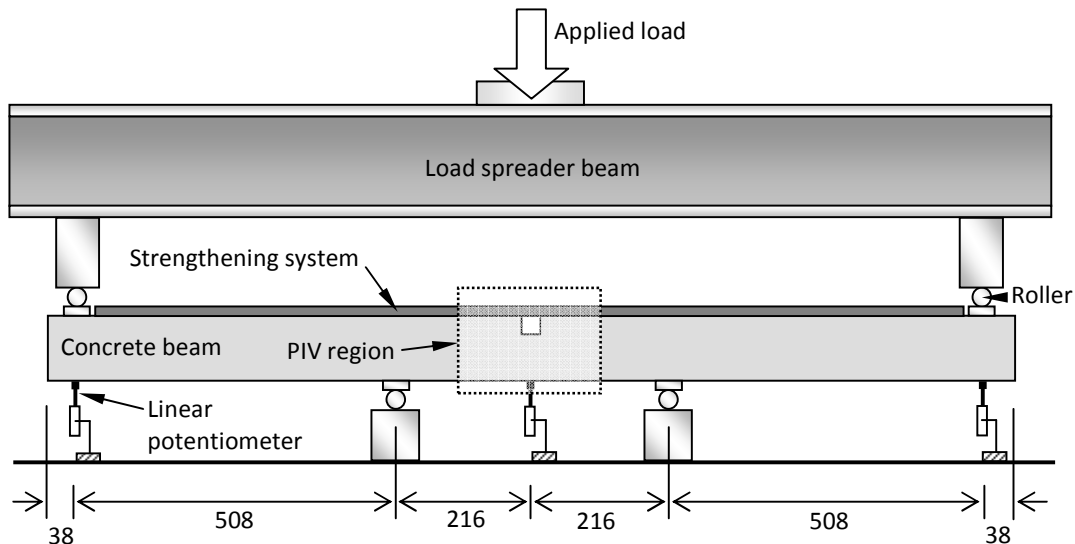

Figure 3. Test setup and instrumentation (all dimensions are in mm)

EXPERIMENTAL RESULTS

Load versus Deflection

Figure 4 shows the total applied load versus midspan vertical deflection behaviour of all six beams tested at ambient temperature; Table 3 provides selected data from these tests. The unstrengthened control beams (RC 20-1 and RC 20-2) displayed typical under-reinforced flexural behaviour. Both unstrengthened beams behaved similarly, and the unstrengthened behaviour thus appears to be repeatable. The average peak load for the unstrengthened beams was 13.4 kN.

The FRP strengthened beams (FRP 20-1 and FRP 20-2) and FRCM strengthened beams (FRCM 20-1 and FRCM 20-2) achieved almost identical ultimate strengths, with average values of 36.6 kN and 36.9 kN, respectively. All strengthened beams had similar cracking moments, although these were difficult to pinpoint exactly due to the load-controlled testing procedure that was used. The FRP strengthened beams showed a considerably stiffer post-cracking response, this despite the fact that the FRCM strengthening system was designed on the basis of equivalent axial stiffness and had a slightly larger flexural lever arm (because of its additional installed thickness as compared to the FRP system). While

the reasons for the less stiff response of the FRCM strengthened beams are not known with certainty, it seems likely that micro-cracking of the FRCM's cementitious mortar resulted in partial redistribution of tensile strains in the FRCM as the load increased, with a subsequent reduction in the system's effective stiffness. Additional testing on beams of various depths/sizes with different levels of FRCM strengthening is required to verify this hypothesis.

Table 3. Summary of experimental results for ambient temperature tests

Specimen ID	Cracking load ¹ (kN)	Ultimate load (kN)	Strength increase ² (%)	Midspan defl. at failure (mm)	Failure Mode ³
RC 20-1	5.9	12.8	--	27.8	CC
RC 20-2	6.4	14.0	--	28.8	CC
FRP 20-1	≈11	35.9	168	24.0	SCD/CS
FRP 20-2	≈10	37.3	178	24.1	SCD/CS
FRCM 20-1	≈11	35.1	162	33.6	SCD/MC
FRCM 20-2	≈10	38.6	188	39.8	SCD/MC

¹ Based on visual examination of load-deflection plots (Figure 4)

² Determined based on the average strength of RC 20-1 and RC 20-2

³ CC = concrete crushing, SCD = shear crack-induced debonding, CS = in the concrete substrate, MC = at the mortar/concrete interface

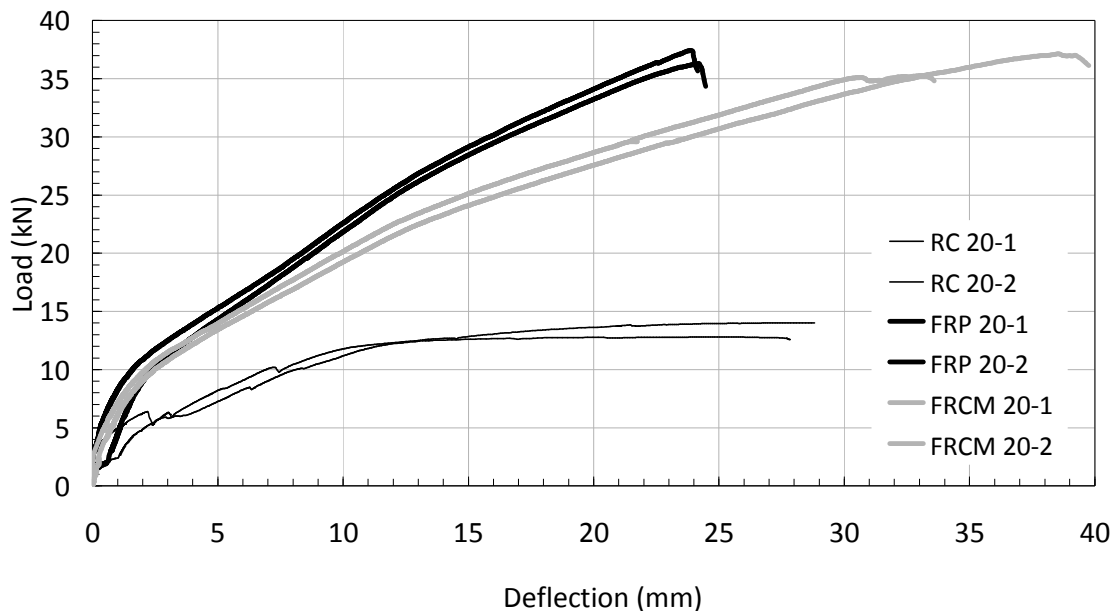

Figure 4. Load versus vertical deflection at midspan for specimens tested at ambient temperature

The strengthened beams exhibited strength increases of more than 160% as compared with the unstrengthened control beams. Clearly, this amount of strengthening falls well outside levels that are currently permitted for design of FRP strengthening systems in real applications [6]. Maximum allowable strength increases are normally in the range of 40 to 60%, depending on the ratio of live loads to dead loads. While it is highly unlikely that such a high level of strengthening would be attempted in practice, the high level used in the current study was intentional since it allows studying the use of FRP and FRCM strengthening systems as primary reinforcement (i.e. it represents an unusually severe loading condition for the strengthening systems).

Failure Modes

Figure 5 provides photos of one unstrengthened beam, one FRP strengthened beam, and one FRCM strengthened beam, all tested at ambient temperature. In all cases the companion beams in each pairing displayed virtually identical behaviour. The unstrengthened beams failed by concrete crushing in the compression zone near midspan, followed by the development of very large curvatures and eventually tensile rupture of the internal reinforcing steel at one of the loading points (Figure 5a).

The FRP strengthened beams failed suddenly and without warning by shear crack induced debonding (SCD) with the critical shear crack initiating at one of the loading points (Figure 5b). As is typically observed for FRP plated beams, the debonding failure occurred within the substrate concrete rather than the adhesive. The debonding was coincident with global shear failure of the cross-section near one of the loading points. It remains unclear whether the shear failure induced the bond failure or vice versa in these tests, but it was noted that a large flexural-shear crack had formed prior to failure (at very large curvatures), and this likely initiated member failure. Shear capacity calculations performed for the test specimens on the basis of simplified empirical rules [10] predicted shear capacities in the range of 55 kN total applied load for these specimens. However, given the relatively small amount of primary flexural steel reinforcement present in the beams, the lower axial stiffness of the external reinforcement (either FRP or FRCM) as compared with steel reinforcement appears to have resulted in lower than expected shear capacity. Because of the unusually high levels of flexural strengthening applied to the beams, very large shear cracks and unusually large curvatures were encountered during testing. These cracks and curvatures limit the applicability of typical simplified empirical shear design equations. This problem has been recognized in available codes for design of concrete elements internally reinforced with lower modulus FRP reinforcing bars [11], but it appears not to have received any significant research attention for FRP or FRCM strengthened beams. The phenomena of premature shear failures in externally strengthened RC elements merits further research.

FRCM strengthened beams also failed in a shear crack induced debonding (SCD) mode, although in this case the failure was more gradual and occurred over a period of about 10 seconds. The FRCM debonding occurred within the TRM system itself, and was characterized by a mixed failure of mortar debonding at the mortar/concrete interface, cohesive failure within the mortar, and PBO fibre pullout. It is likely that this beneficial

mixed failure mode, in particular the fibre pullout, contributed to the more gradual nature of failure for the FRCM strengthened beams.

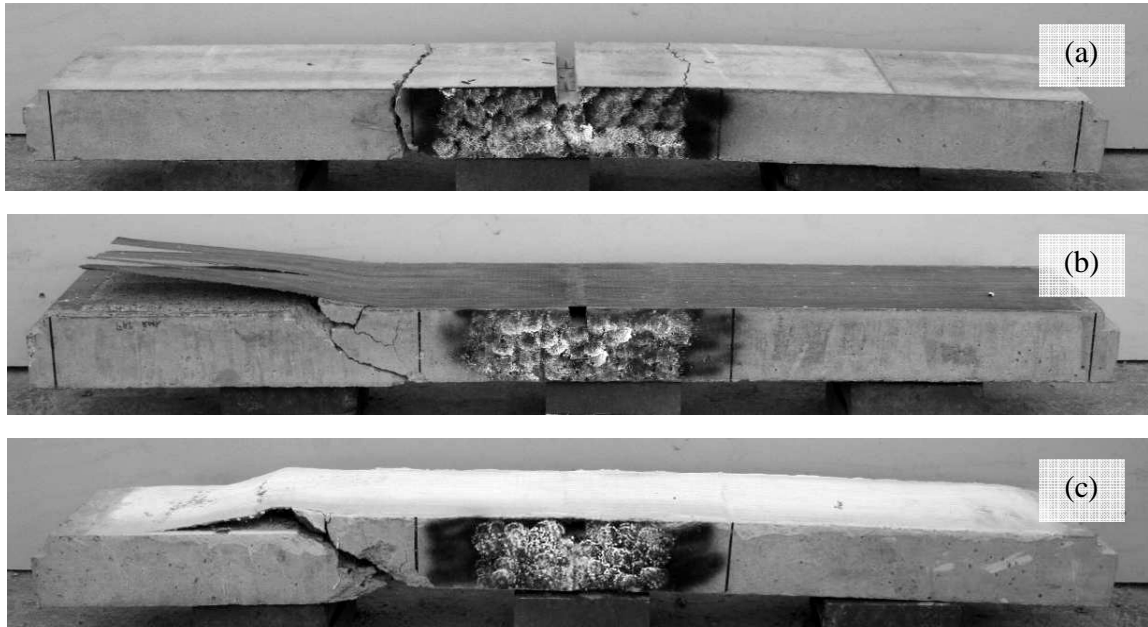

Figure 5. Typical failure modes for (a) unstrengthened beams, (b) FRP strengthened beams, and (c) FRCM strengthened beams tested at ambient temperature

Strains in the Strengthening Systems

It is difficult to accurately measure strains on the surface of cementitious materials (such as the FRCM system studied in the current paper) using conventional foil strain gauges, a novel optical technique [9] is therefore being attempted to indirectly measure the strains in the strengthening systems under increasing loads. Digital images of the beams (with the field of view shown in Figures 3 and 6) were taken every five seconds during testing using a 10.1 Megapixel digital camera as each beam was loaded until failure. Normalised cross-correlation as coded in the geoPIV software [9] can subsequently be used to define particular regions of interest in the first image and then track each of these regions in each subsequent image (with the applied load known at the instant that each image was captured). As shown schematically in Figure 6, the regions of interest are being chosen as square patches of 64×64 pixels in two vertical lines. In order for these patches to be accurately tracked they are required to contain sufficient variation in the intensity and distribution of pixel colours to be unmistakable in subsequent images; a white paint texturizing effect was therefore applied to the surface of each of the beams to impart a random, high-contrast, image texture. The precision of this measurement technique is typically better than one tenth of one pixel [9]. By tracking patches horizontally, as shown in Figure 5a, it should be possible to calculate flexural strains over any desired gauge length within the field of view [9]. For the current tests this gauge length is being taken as 75 mm

(equivalent to the unbonded length of the strengthening system over the notch at midspan). Once a vertical strain profile is obtained over the depth of the beam, this strain profile will be linearly projected to the tensile face of the beam and taken to indicate the strain in the EB strengthening system (assuming perfect bond and a linear strain profile in the concrete). The results will be presented at the conference.

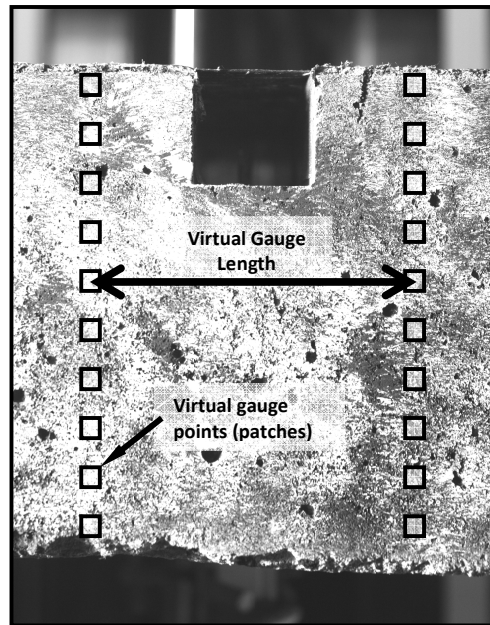

Figure 5. Schematics showing optical technique used to measure strains in the strengthening systems during testing

CONCLUSIONS

The following conclusions can be drawn on the basis of the pilot testing at ambient temperature presented in this paper:

- The FRCM strengthening system studied herein can be effectively used, without supplemental anchorage, to strengthen RC beams in bending.
- Unlike currently available TRM systems based on carbon FRP textiles, the PBO-based FRCM system tested herein was able to provide similar strength enhancement as compared with an EB carbon/epoxy FRP strengthening system, although with a slightly lower flexural stiffness.
- The FRCM system tested herein appears to be a strong candidate for use in strengthening applications where fire exposure is a realistic concern. Its inherent non-combustibility and superior performance at temperatures up to 120°C make it an attractive system for structural strengthening in buildings, and future research is aimed at specifically investigating its mechanical performance under fire exposure.

REFERENCES

1. Triantafillou, T. C. and Papanicolaou, C. G., Shear strengthening of reinforced concrete members with textile reinforced mortar (TRM) jackets. *Materials and Structures*, **39(1)**, 93-103 (2006).
2. Fallis, G. J., Innovation for renovation: Cementitious matrix is used to bond high-strength polymeric mesh to concrete and masonry. *Concrete International*, **31(4)**, 62-64 (2009).
3. Bisby, L. A., Burke, P. J. and Green, M. F., Comparative performance of externally-bonded and near surface mounted FRP strengthening systems at high temperatures. *5th International Conference on Advanced Composite Materials in Bridges and Structures (ACMBS-V)*, Winnipeg, Canada, September 22-24, 2008.
4. Bournas, D. A., Lontou, P. V., Papanicolaou, C. G. and Triantafillou, T., Textile-reinforced mortar versus fiber-reinforced polymer confinement in reinforced concrete columns. *ACI Structural Journal*, **104(6)**, 740-748 (2007).
5. Kodur, V. K. R., Bisby, L. A. and Green, M. F., FRP retrofitted concrete under fire conditions. *Concrete International*, **28(12)**, 37-44 (2006).
6. ACI, *Guide for the Design and Construction of Externally Bonded FRP Systems for Strengthening Concrete Structures, 440.2R-08*. American Concrete Institute, USA, (2008).
7. Ruredil, *X Mesh Gold Data Sheet*. Ruredil SPA, Milan, Italy, 2009.
8. Instituto Giordano, *Classification Report No. 237540: Classification of reaction to fire of construction products in accordance with UNI EN 13501-1:2007* (2008).
9. White, D. J., Take, W. A. and Bolton, M. D., Soil Deformation measurement using particle image velocimetry (PIV) and photogrammetry. *Géotechnique*, **53(7)**, 619-631 (2003).
10. CSA, *Design of Concrete Structures, CAN/CSA A23.3-04*. Canadian Standards Association, Canada, (2004).
11. ACI, *Guide for the Design and Construction of Structural Concrete Reinforced with FRP Bars, 440.1R-06*. American Concrete Institute, USA, (2006).