



# THE UNIVERSITY *of* EDINBURGH

## Edinburgh Research Explorer

### Gas loading apparatus for the Paris-Edinburgh press

**Citation for published version:**

Bocian, A, Bull, CL, Hamidov, H, Loveday, JS, Nelmes, RJ & Kamenev, KV 2010, 'Gas loading apparatus for the Paris-Edinburgh press' *Review of Scientific Instruments*, vol. 81, no. 9, 093904 . DOI: 10.1063/1.3480555

**Digital Object Identifier (DOI):**

[10.1063/1.3480555](https://doi.org/10.1063/1.3480555)

**Link:**

[Link to publication record in Edinburgh Research Explorer](#)

**Document Version:**

Publisher's PDF, also known as Version of record

**Published In:**

*Review of Scientific Instruments*

**Publisher Rights Statement:**

Publisher's Version/PDF: author can archive publisher's version/PDF

**General rights**

Copyright for the publications made accessible via the Edinburgh Research Explorer is retained by the author(s) and / or other copyright owners and it is a condition of accessing these publications that users recognise and abide by the legal requirements associated with these rights.

**Take down policy**

The University of Edinburgh has made every reasonable effort to ensure that Edinburgh Research Explorer content complies with UK legislation. If you believe that the public display of this file breaches copyright please contact [openaccess@ed.ac.uk](mailto:openaccess@ed.ac.uk) providing details, and we will remove access to the work immediately and investigate your claim.



## Gas loading apparatus for the Paris-Edinburgh press

A. Bocian, C. L. Bull, H. Hamidov, J. S. Loveday, R. J. Nemes et al.

Citation: *Rev. Sci. Instrum.* **81**, 093904 (2010); doi: 10.1063/1.3480555

View online: <http://dx.doi.org/10.1063/1.3480555>

View Table of Contents: <http://rsi.aip.org/resource/1/RSINAK/v81/i9>

Published by the [American Institute of Physics](#).

---

### Related Articles

Nonlinear dynamics of inhomogeneous mismatched charged particle beams

*Appl. Phys. Lett.* **101**, 074106 (2012)

Active spectroscopic measurements of the bulk deuterium properties in the DIII-D tokamak (invited)

*Rev. Sci. Instrum.* **83**, 10D529 (2012)

Versatile cold atom target apparatus

*Rev. Sci. Instrum.* **83**, 073112 (2012)

Absolute beam brightness detector

*Rev. Sci. Instrum.* **83**, 02A714 (2012)

Beam injection improvement for electron cyclotron resonance charge breeders

*Rev. Sci. Instrum.* **83**, 02A909 (2012)

---

### Additional information on *Rev. Sci. Instrum.*

Journal Homepage: <http://rsi.aip.org>

Journal Information: [http://rsi.aip.org/about/about\\_the\\_journal](http://rsi.aip.org/about/about_the_journal)

Top downloads: [http://rsi.aip.org/features/most\\_downloaded](http://rsi.aip.org/features/most_downloaded)

Information for Authors: <http://rsi.aip.org/authors>

## ADVERTISEMENT

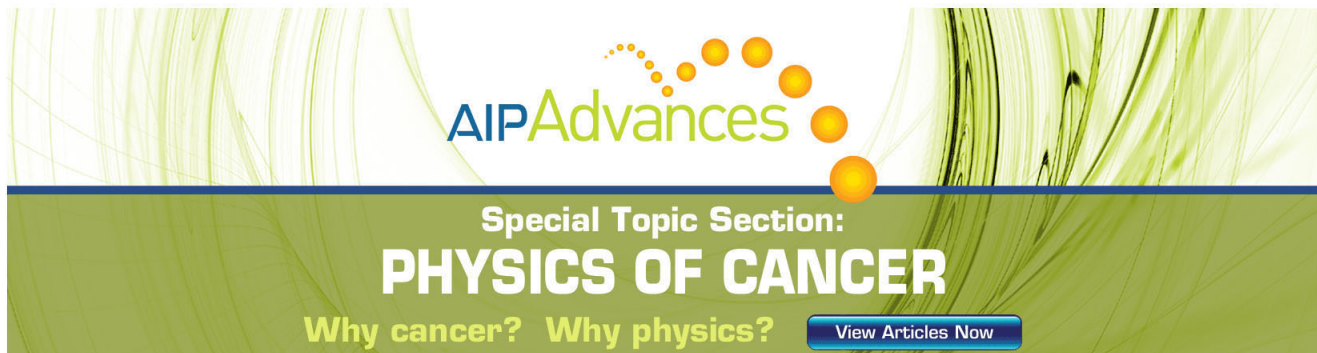

**AIP Advances**

Special Topic Section:  
**PHYSICS OF CANCER**

Why cancer? Why physics? [View Articles Now](#)

## Gas loading apparatus for the Paris-Edinburgh press

A. Bocian,<sup>1</sup> C. L. Bull,<sup>2</sup> H. Hamidov,<sup>2</sup> J. S. Loveday,<sup>2</sup> R. J. Nelmes,<sup>2</sup> and K. V. Kamenev<sup>1,a)</sup>

<sup>1</sup>*School of Engineering and Centre for Science at Extreme Conditions, University of Edinburgh, Edinburgh EH9 3JZ, United Kingdom*

<sup>2</sup>*SUPA, School of Physics and Astronomy and Centre for Science at Extreme Conditions, University of Edinburgh, Edinburgh EH9 3JZ, United Kingdom*

(Received 10 June 2010; accepted 28 July 2010; published online 13 September 2010)

We describe the design and operation of an apparatus for loading gases into the sample volume of the Paris-Edinburgh press at room temperature and high pressure. The system can be used for studies of samples loaded as pure or mixed gases as well as for loading gases as pressure-transmitting media in neutron-scattering experiments. The apparatus consists of a high-pressure vessel and an anvil holder with a clamp mechanism. The vessel, designed to operate at gas pressures of up to 150 MPa, is used for applying the load onto the anvils located inside the clamp. This initial load is sufficient for sealing the pressurized gas inside the sample containing gasket. The clamp containing the anvils and the sample is then transferred into the Paris-Edinburgh press by which further load can be applied to the sample. The clamp has apertures for scattered neutron beams and remains in the press for the duration of the experiment. The performance of the gas loading system is illustrated with the results of neutron-diffraction experiments on compressed nitrogen. © 2010 American Institute of Physics. [doi:10.1063/1.3480555]

### I. INTRODUCTION

The Paris-Edinburgh (PE) press<sup>1</sup> is an opposed-anvil device widely used for neutron scattering at high pressure. For a relatively small and light frame, it provides a high load capacity of up to 250 tonnes combined with a large sample volume of tens of cubic millimeters. Until now it has been successfully used with a number of solid and liquid samples, and pressure media, which are relatively easy to load into the sample volume. However, loading samples that are gaseous under ambient conditions presents a challenge because of the need to load at sufficient density to allow high sample pressures to be achieved by subsequent compression of the gasket.

There are two possible solutions to this problem. One is to cool down the gas below its liquefaction temperature and load it as liquid. The other approach is to load the gas at high pressure at room temperature, and this method is well established for diamond-anvil cells (see Sec. III for details). However, it is a challenge for a device like the PE press because of the large sample volume and the size of the press, which is much larger than a diamond-anvil cell. There have been several cryogenic techniques developed to load liquefied gases into PE press. Klotz *et al.*<sup>2</sup> developed a technique in which an aluminum ring with two capillary feedthroughs is placed around the gasket. This creates a chamber into which the gas delivered through a capillary is condensed following the cool down of the majority of the cell below the liquefaction point of the gas. The initial gap between the gasket and the anvil is closed after the chamber is filled with the liquid and a load of

15 tonnes is applied to break the aluminum ring and to seal the gasket. The ring is then removed prior to high-pressure experiments.

A different approach was reported by Loveday *et al.*<sup>3</sup> In this method, the anvils of the Paris-Edinburgh press are separated from the cell and cooled down in a liquid nitrogen bath that is considerably faster than the process involving cooling the whole press. The sample is precooled to its stability region, poured into the gasket, which is placed on top of one of the anvils, and thus frozen into the sample volume. Next, the second anvil is placed on the top of the gasket and the centering rings holding the anvils are connected by bolts and firmly tightened. The whole assembly is then promptly transferred into the PE press and a load of 5 tonnes is applied to seal the gasket.

Another system for gas loading the PE press was presented by Lipp *et al.*<sup>4</sup> In this design, the anvils are thermally insulated from the rest of the press by special inserts for the cryoloading to be performed *in situ*. Gas is then condensed into the sample volume through a capillary prior to sealing.

Cryogenic loading techniques have several disadvantages. They are only suitable for gases with liquefaction temperatures above or equal to that of nitrogen. Equally, they cannot readily be used to load gas mixtures in which different gases have different liquefaction temperatures. Moreover, in the case where a gas is loaded as a pressure medium, boiling of the liquefied gas can cause “washing out” of all or part of the sample from the sample space.

The ability to load gases at room temperature in large volume devices such as the PE press would overcome these problems bringing about several benefits. It would allow us more readily to study samples loaded as gases or gas mixtures under high pressure. It would also make it possible to replace relatively incompressible liquid or solid pressure-

<sup>a)</sup>Electronic mail: k.kamenev@ed.ac.uk.

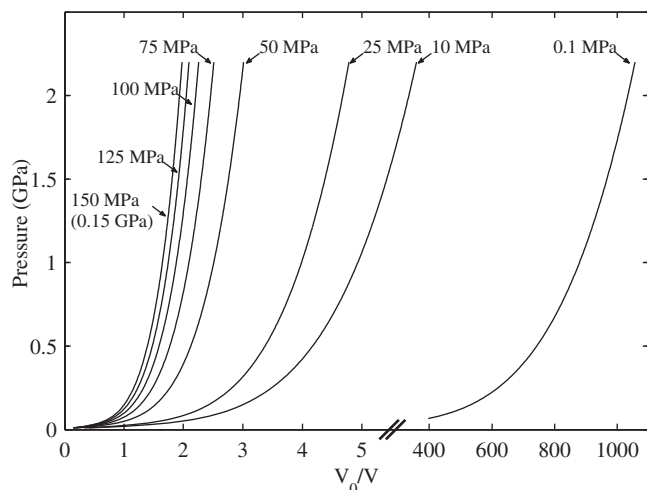

FIG. 1. Pressure as a function of compression ratio for nitrogen loaded at various initial pressures. The pressure at  $V=V_0$ , where  $V_0$  is the initial volume, is shown above the corresponding curve.

transmitting media with ones loaded as gases in order to achieve more quasihydrostatic-compression conditions.

## II. LOADING PRESSURE

It is necessary to load gaseous samples with sufficient density in the sample volume so that upon compression a reasonable pressure load performance is achieved. The required loading density can be estimated from the equation of state of the gas and we illustrate it here using the example of nitrogen.<sup>5,6</sup> Figure 1 shows the calculated variation of pressure with compression ratio ( $V_0/V$ ) for a range of initial gas loading pressures between 0.1 MPa (atmospheric pressure) and 150 MPa. To solidify nitrogen at room temperature it must be compressed to a molar volume of less than  $21.4 \text{ cm}^3/\text{mole}$  that is equivalent to a pressure of  $\sim 2 \text{ GPa}$ ,<sup>6</sup> and the compression ratio required to achieve this depends on the initial pressure at which the gas was loaded, as shown in Fig. 1. Nitrogen compressed at room temperature to 125 MPa has a molar volume of  $44.86 \text{ cm}^3/\text{mole}$  meaning that a compression ratio of about two would be needed to reach the transition into the solid phase for nitrogen. This level of compression ratio can be readily achieved with standard single-toroidal anvils<sup>7,8</sup> and gaskets<sup>9</sup> used in the Paris-Edinburgh press. Indeed, gases precompressed to about 100 MPa have densities similar to those of the liquefied gas at ambient or low pressure. From this state, they can be taken to higher pressures inside the pressure cell.

## III. EXISTING AMBIENT TEMPERATURE GAS LOADING DEVICES AND DESIGN CHALLENGES

In order to load compressed gases into the sample gasket, a special gas loading device needs to be constructed. Several gas loading vessels have been developed for diamond anvil cells (DACs).<sup>10-13</sup> In these systems, a DAC is placed inside the pressure vessel that is filled with compressed gas. Load is then transmitted to drive the anvils together by means of a mechanical drive that is operated through a sealed gearbox from outside the vessel.

DACs are small and can be easily accommodated inside the gas loader. Additionally, because of the much smaller surface area of the diamond anvils used in a DAC, the force required to compress the gasket in these cells is much smaller than for large volume pressure cells such as the Paris-Edinburgh press. Making a gas loader capable of accommodating the whole PE press is not possible because of its overall size. The stresses in such a device would be considerable even for a low gas pressure created inside the vessel.

A different approach is to inject the compressed gas via a capillary directly into the sample volume through a hole drilled in the gasket, and we are aware of past attempts to implement this method.<sup>14</sup> Although technically feasible, this type of loading is difficult to perform, taking account of the gas pressures involved and to date, does not produce consistent results.<sup>14</sup>

We have therefore focused our design effort on a “midrange” solution of building a clamp or holder for the anvils, which is small enough to fit inside a gas loader of reasonable size. Combined with a custom built pressure vessel, this holder is used for clamping the compressed gas once loaded inside the gasket. It can then be transferred into the Paris-Edinburgh press.

## IV. APPARATUS

The experimental setup for loading high-pressure gases consists of a locking clamp and a pressure vessel located on the table of a hydraulic press and connected to a gas compressor. Below, we describe the design of each of the components and the operational procedure.

### A. Locking clamp

The key function of the clamp is to hold the anvils under load and enable their transfer between the pressure vessel and the Paris-Edinburgh press after the gas has been sealed inside the gasket. Since it is to remain in the PE press for the duration of the experiment, the clamp must have apertures, which do not obstruct the scattered neutron beams.

A detailed schematic and photograph of the clamp are shown in Fig. 2. The top seat supporting the top anvil is screwed into the body of the clamp, thus stopping it from moving with respect to the clamp during the operation of the gas loader. The key feature of the clamp is the use of eight spring-loaded latches that support the bottom seat and the anvil. When the compressive force is applied (in the way explained in Sec. IV D), the bottom seat and anvil move toward the top seat and anvil. As this happens the latches move inwards to provide support. The mating faces of the latches and the bottom seat have  $7^\circ$  taper to ensure that the smallest movement of the anvil will result in further engagement of the latches. The latches engage continuously as the anvils are pushed toward each other and the gasket is being compressed. Upon release of the compressive force, the latches lock the anvils in place.

The clamp presented in this report has been designed for use with the Paris-Edinburgh V4 press that has four tie-rods and is used with anvils bevelled to  $7^\circ$ .<sup>15</sup> The tie-rods obstruct

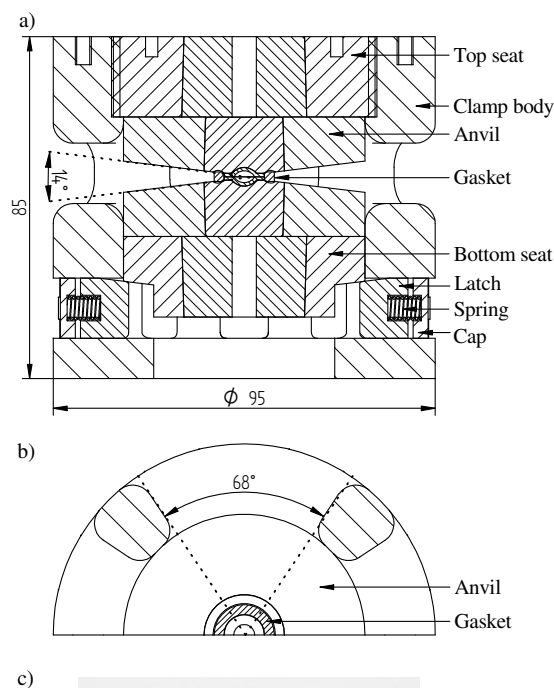

FIG. 2. (a) Vertical and (b) horizontal cross-sectional views of the clamp with key dimensions and scattering angles indicated. Latches are shown in the initial position, i.e., before the loading commences. (c) Photograph of the clamp assembled with anvils and seats.

the scattered beams from the sample in four segments. Therefore, four apertures were made in the clamp body to match the opening angles of the press in the horizontal plane [Fig. 2(b)]. In the vertical plane, the clamp provides ample opening for the 14° scattering segment defined by the anvils [Fig. 2(a)]. The scattered beams are thus unaffected by the presence of the clamp. For the VX two-tie-rod variant of the PE press,<sup>16</sup> a two-aperture design of the clamp can be implemented.

In order to optimize the dimensions of the collar and to ensure that the backlash in the latches is kept to a minimum, we have performed finite element analysis of the stress distribution and deformation using the ANSYS<sup>®</sup> software package.<sup>17</sup> Based on this analysis, it was decided to manufacture the clamp and the latches using 819AW maraging steel from Aubert & Duval with an ultimate tensile strength (UTS) of 1900 N/mm<sup>2</sup>.<sup>18</sup>

The maximum load supported by the latches and the clamp is 25 tonnes that transfers into a sample pressure of above 900 MPa. However, because of the large amount of energy stored in the compressed gas, a safety factor of 3.5 is

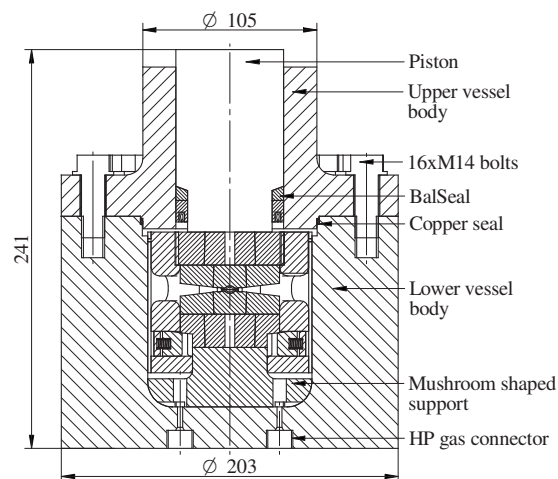

FIG. 3. A cross-sectional view of the pressure vessel assembled with the clamp inside. The piston is shown in the initial position.

applied. This reduces the operational maximum load for the latches to 7 tonnes. For this load, the estimated backlash in the latches is 0.04 mm.

## B. Pressure vessel

The purpose of the pressure vessel is twofold. It is used as a container for pressurizing the gas to the pressure at which it is to be loaded into the sample volume. It also provides the means for applying load to compress the anvils and the pressurized gas inside the gasket until the latches engage.

A schematic of the pressure vessel with the clamp inside is shown in Fig. 3. The major components of the pressure vessel are the lower vessel body, upper vessel body, piston and mushroom shaped support. The upper vessel body is secured to the lower body by 16 M14 high-tensile bolts and sealed by a static copper seal, which is deformed when the bolts are tightened. The piston is sealed with a dynamic high-pressure seal manufactured by BalSeal<sup>19</sup> and can slide inside the bore of the upper vessel body. The mushroom shaped support at the bottom of the pressure vessel is used to apply load to the bottom anvil and seats of the clamp. Two high-pressure ports at the bottom of the vessel are used as an inlet for the gas from the compressor and as an outlet to the pressure gauge, respectively. The vessel is mounted on the table of a 50 tonne hydraulic press that is used for pushing the piston in order to apply the load onto the anvils via the mushroom support.

All parts of the vessel apart from the seals and the M14 bolts are made of fully hardened BERYLCO-25 alloy with the UTS of 1440 N/mm<sup>2</sup>.<sup>20</sup> The vessel has been designed using ANSYS<sup>®</sup> software<sup>17</sup> to operate up to 150 MPa with safety factor of 3.5 (the maximum pressure the vessel can withstand equals 530 MPa). For safety proofing, the vessel has been tested using pentane as a pressure-transmitting medium to 225 MPa.

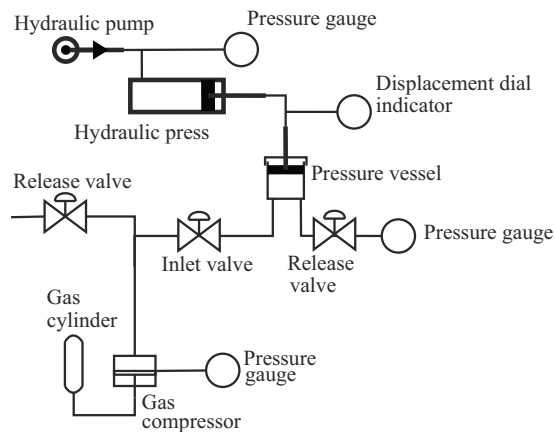

FIG. 4. Schematic diagram of the gas and hydraulic installation of the gas loading system.

### C. Gas and hydraulic installation

A schematic diagram of the hydraulic and pneumatic system is shown in Fig. 4. The installation consists of the pressure vessel, hydraulic press with hand pump, gas compressor and associated tubing and connectors. Low pressure gas from a standard cylinder is supplied to the compressor. The gas from the compressor is delivered into the pressure vessel. The hydraulic pump is connected to the ram of the press by a flexible hose.

For improved operational safety, both the oil pump and the gas compressor are placed outside the room in which the gas loader is set up and the gas loading is performed remotely. A video camera is used for monitoring the displacement gauge installed on the piston of the hydraulic press. The gauge measures the change in the distance between the piston and the top of the upper vessel body, and provides information about the gasket compression. A photograph of the gas loader setup is shown in Fig. 5.



FIG. 5. Gas loader assembled in the hydraulic press. Visible are the pressure vessel, the dial gauge monitoring the piston position, and the pressure gauge showing pressure inside the vessel.

### D. Experimental procedure

Before the loading commences, the clamp is assembled with an empty gasket placed between the anvils, as shown in Fig. 2. The voids between the anvils and in the windows of the clamp are then filled with spacers manufactured from aluminum and molded plastic in order to reduce the gas volume inside the pressure vessel during the loading. A 2-mm-thick aluminum safety sleeve is placed around the clamp, in order to protect the operator during the removal of the collar after gas loading in the unlikely event that the gasket fails. The assembly is then placed into the pressure vessel with the bottom seat resting on the mushroom support. The upper pressure vessel body, with the piston engaged into it, is then placed on the vessel and the bolts are tightened. The total unfilled volume inside the assembled gas loader is estimated to be less than 30 cm<sup>3</sup>.

After the completion of the assembly, the sample gas from the compressor is supplied into the vessel. As the gas pressure builds up in the vessel, it pushes on the piston. In order to stop the piston from moving upwards, an equalizing force is applied to the piston using the hydraulic press in such a way that the piston remains in its original position. On achieving the desired gas pressure inside the pressure vessel, a load is applied to the piston through the hydraulic ram of the press in order to engage the anvils. As the piston moves down, it also compresses the gas inside the vessel. We have found that for the gas inside the vessel at 125 MPa this generates the extra pressure of an order of 10 MPa.

The piston pushes on the top seat and the mushroom support forces the anvils toward each other, thus closing and compressing the gasket. The increase in the hydraulic load versus the displacement of the piston is used to monitor the gasket compression. It is found that a load of 5 tonnes compresses the gasket by 0.5 mm that is sufficient for sealing the gas inside the gasket. It is worth mentioning here that, although the load required to seal the gasket is only of an order of 5 tonnes, a much higher capacity of the hydraulic ram is required to overcome the upward force on the piston originating from the compressed gas inside the vessel as mentioned above. As a result of the large diameter of the piston, the force can be as high as 43 tonnes for 130 MPa of gas pressure in the vessel.

After the procedure of gasket loading and sealing is completed, the hydraulic load on the piston is released and the surplus gas is vented out of the vessel. Finally, the upper vessel body is removed and the clamp with the anvils, gasket, and sample loaded is transferred into the Paris-Edinburgh press.

### V. THE LOADING OF NITROGEN GAS

For testing the performance of the gas loader, we chose nitrogen as a sample. Several experiments have been performed on the HiPr diffractometer (ISIS Neutron Spallation Source, Rutherford Appleton Laboratory, U.K.) during which nitrogen has been loaded into the gasket at a pressure of approximately 125 MPa. A small sample of lead (80 mg) was also placed inside the gasket in order to act as a pressure

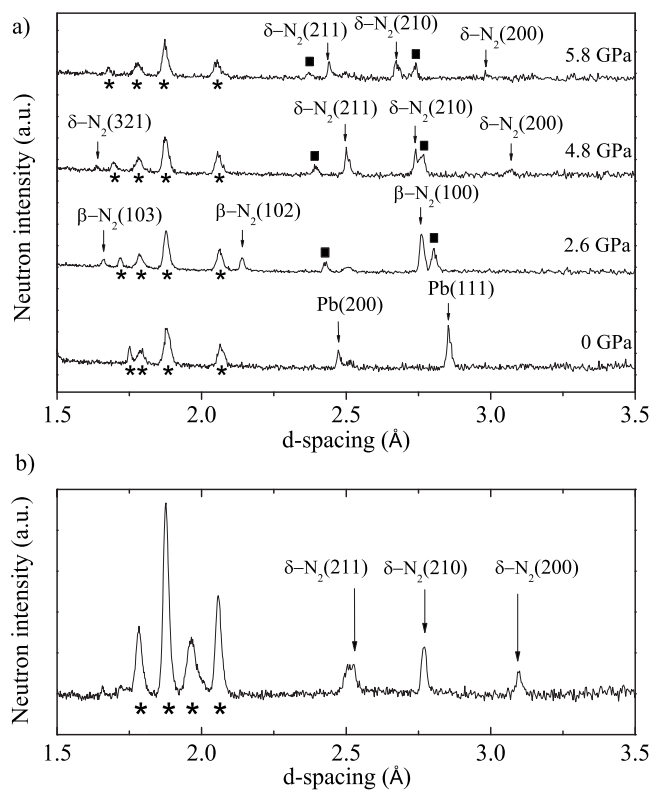

FIG. 6. (a) Diffraction patterns of nitrogen initially loaded at 125 MPa and compressed in the Paris-Edinburgh press; lead was used as a pressure reference. The reflections from  $\beta$  and  $\delta$  phases of nitrogen, as well as from lead, are marked (Refs. 23–25). Asterisks denote reflections from the tungsten-carbide anvils. The lead reflections are indexed in the 0 GPa pattern with recurring reflections denoted by squares at elevated pressures. (b) Diffraction pattern of  $\delta$ -nitrogen at 4.8 GPa loaded without lead [pressure was calculated using the equation of state of nitrogen (Ref. 22)].

reference during the neutron diffraction measurement. The pressure is determined from the derived unit cell volume of the lead sample and its equation of state.<sup>21</sup>

It is known that nitrogen solidifies into the hexagonal ( $P6_3mmc$ )  $\beta$  phase at above 2 GPa at room temperature.<sup>6</sup> After further compression, it undergoes another phase transition into a cubic ( $Pm3n$ )  $\delta$  phase at a pressure of around 4.8 GPa.<sup>22</sup> In our experiments, we have observed both solid phases as can be seen in the diffraction patterns presented in Fig. 6(a).

A diffraction pattern obtained from a loading performed without lead is shown in Fig. 6(b). For this loading, half of the gasket volume was filled with the TiZr in order to improve the pressure performance.

The pressure versus load curves determined during several loadings is summarized in Fig. 7. It shows that, by applying the load of about 90 tonnes, a pressure of 6 GPa can be generated in the sample volume.

## VI. CONCLUSIONS

We have designed a system for loading gases into the gasket of the Paris-Edinburgh press at high pressure and room temperature. The performance of the system has been tested in neutron-diffraction experiments with nitrogen as a sample. Loading the gas at a pressure of 125 MPa allowed us

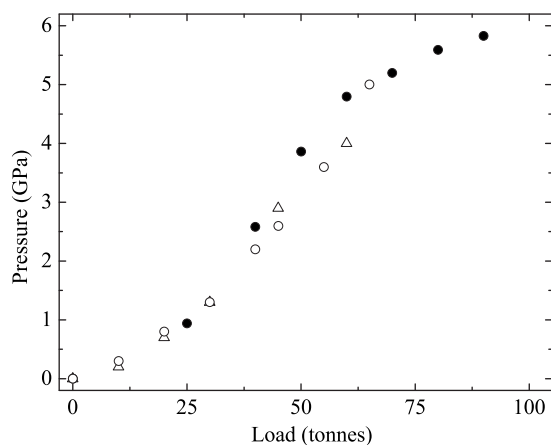

FIG. 7. Pressure-load performance for nitrogen samples loaded at 125 MPa and compressed in the Paris-Edinburgh press as determined using the lead equation of state (Ref. 21). Different symbols present results from several individual loadings.

to reach a pressure of 6 GPa during compression in the PE press with single-toroidal anvils at 90 tonnes.

For gases which have lower densities at ambient conditions, such as hydrogen or helium, or in the instances where higher pressure is required, there are several ways in which the compression of the sample can be enhanced. One of them is to use double-toroidal anvils, which have been proven to work to loads of up to 250 tonnes.<sup>26</sup> Improvement in the loading performance can also be made by increasing the initial gas pressure. The current version of the gas loader is rated to 150 MPa but this can be increased by designing a stronger pressure vessel and using a hydraulic press with higher capacity. Finally, for loading hydrogen, some components of the system need to be redesigned to avoid use of materials such as maraging steel, which are prone to hydrogen embrittlement.

## ACKNOWLEDGMENTS

The authors gratefully acknowledge the technical support provided by P. Aitken (CSEC) as well as by ISIS staff in particular C. Barry, C. Goodway, M. Kibble, and E. Quinn. The authors thank Dr. S. Klotz for helpful discussions. They also thank Professor T. Yagi for allowing them to use the sliding seal designed for his gas loading system (Ref. 10). This work was carried out with the support of EPSRC Grant No. EP/E031099/1, and other support from STFC and the ISIS Facility.

<sup>1</sup> J. M. Besson, R. J. Nelmes, G. Hamel, J. S. Loveday, G. Weill, and S. Hull, *Physica B* **180–181**, 907 (1992).

<sup>2</sup> S. Klotz, M. Gauthier, J. M. Besson, G. Hamel, R. J. Nelmes, J. S. Loveday, R. M. Wilson, and W. G. Marshall, *Appl. Phys. Lett.* **67**, 1188 (1995).

<sup>3</sup> J. S. Loveday, G. Hamel, R. J. Nelmes, S. Klotz, M. Guthrie, and J. M. Besson, *High Press. Res.* **17**, 149 (2000).

<sup>4</sup> M. J. Lipp, W. J. Evans, and C. S. Yoo, *Rev. Sci. Instrum.* **76**, 053903 (2005).

<sup>5</sup> *Thermophysical Properties of Fluids*, CRC Handbook of Chemistry and Physics, 90th ed., edited by D. R. Lide (CRC/Boca Raton, FL, Taylor & Francis/London, 2010).

<sup>6</sup> R. L. Mills, D. H. Liebenberg, and J. C. Bronson, *J. Chem. Phys.* **63**, 4026 (1975).

<sup>7</sup> L. G. Khvostantsev, V. A. Sidorov, and A. P. Novikov, *High Temp. - High Press.* **9**, 637 (1977).

- <sup>8</sup>L. G. Khvostantsev, *High Temp. - High Press.* **16**, 165 (1983).
- <sup>9</sup>W. G. Marshall and D. J. Francis, *J. Appl. Crystallogr.* **35**, 122 (2002).
- <sup>10</sup>T. Yagi, H. Yusa, and M. Yamakata, *Rev. Sci. Instrum.* **67**, 2981 (1996).
- <sup>11</sup>S.-i. Machida, H. Hirai, H. Gotou, T. Sakakibara, and T. Yagi, *Rev. Sci. Instrum.* **81**, 033901 (2010).
- <sup>12</sup>M. Rivers, V. B. Prakapenka, A. Kubo, C. Pullins, C. M. Holl, and S. D. Jacobsen, *High Press. Res.* **28**, 273 (2008).
- <sup>13</sup>R. L. Mills, D. H. Liebenberg, J. C. Bronson, and L. C. Schmidt, *Rev. Sci. Instrum.* **51**, 891 (1980).
- <sup>14</sup>S. Klotz, private communication (2007).
- <sup>15</sup>J. M. Besson, Ph. Pruzan, S. Klotz, G. Hamel, B. Silvi, R. J. Nelmes, J. L. Loveday, R. M. Wilson, and S. Hull, *Phys. Rev. B* **49**, 12540 (1994).
- <sup>16</sup>S. Klotz, G. Hamel, and J. Frelat, *High Press. Res.* **24**, 219 (2004).
- <sup>17</sup>ANSYS, Inc., <http://www.ansys.com/>.
- <sup>18</sup>Aubert & Duval, <http://www.aubertduval.com/>.
- <sup>19</sup>Bal Seal Engineering, Inc., <http://www.balseal.com/>.
- <sup>20</sup>NGK Berylco U.K. Ltd., <http://www.ngkberylco.co.uk/>.
- <sup>21</sup>J. M. Besson, S. Klotz, G. Hamel, W. G. Marshall, R. J. Nelmes, and J. S. Loveday, *Phys. Rev. Lett.* **78**, 3141 (1997).
- <sup>22</sup>B. Olinger, *J. Chem. Phys.* **80**, 1309 (1984).
- <sup>23</sup>D. Schiferl, D. T. Cromer, R. R. Ryan, A. C. Larson, R. LeSar, and R. L. Mills, *Acta Crystallogr. C* **39**, 1151 (1983).
- <sup>24</sup>D. T. Cromer, R. L. Mills, D. Schiferl, and L. A. Schwalbe, *Acta Crystallogr. B* **37**, 8 (1981).
- <sup>25</sup>H. P. Klug, *J. Am. Chem. Soc.* **68**, 1493 (1946).
- <sup>26</sup>S. Klotz, J. M. Besson, G. Hamel, R. J. Nelmes, J. S. Loveday, W. G. Marshall, and R. M. Wilson, *Appl. Phys. Lett.* **66**, 1735 (1995).