



THE UNIVERSITY *of* EDINBURGH

Edinburgh Research Explorer

Current and Future Developments of the C-GEN Lightweight Direct Drive Generator for Wave & Tidal Energy

Citation for published version:

Hodgins, N, McDonald, A, Shek, J, Keysan, O & Mueller, M 2009, Current and Future Developments of the C-GEN Lightweight Direct Drive Generator for Wave & Tidal Energy. in Proceedings of the 8th European Wave and Tidal Energy Conference, Uppsala, Sweden, 2009. pp. 352-359.

Link:

[Link to publication record in Edinburgh Research Explorer](#)

Document Version:

Peer reviewed version

Published In:

Proceedings of the 8th European Wave and Tidal Energy Conference, Uppsala, Sweden, 2009

Publisher Rights Statement:

© Proceedings of the 8th European Wave and Tidal Energy Conference, Uppsala, Sweden, 2009

General rights

Copyright for the publications made accessible via the Edinburgh Research Explorer is retained by the author(s) and / or other copyright owners and it is a condition of accessing these publications that users recognise and abide by the legal requirements associated with these rights.

Take down policy

The University of Edinburgh has made every reasonable effort to ensure that Edinburgh Research Explorer content complies with UK legislation. If you believe that the public display of this file breaches copyright please contact openaccess@ed.ac.uk providing details, and we will remove access to the work immediately and investigate your claim.



Current and Future Developments of the C-GEN Lightweight Direct Drive Generator for Wave & Tidal Energy

N. Hodgins, A. McDonald, J. Shek, O. Keysan & M. Mueller

Institute for Energy Systems
Joint Research Institute for Energy
The School of Engineering
The University of Edinburgh,
The Kings Buildings, Edinburgh, Scotland, EH9 3JL
E-mail: N.Hodgins@ed.ac.uk

Abstract

The C-GEN is a novel permanent magnet generator aimed at reducing overall system mass in direct drive power takeoff applications. The design of a C-GEN generator requires the combination of electromagnetic, structural and thermal models. Two rotary prototypes of 15 & 20kW have been constructed and tested and the 15kW prototype has been fitted to a wind turbine. A 1kW linear generator has been tested and is being modified for flooded operation meanwhile a larger 50kW prototype is being designed. A feasibility study of C-GEN technology in four different wave and tidal projects is being undertaken.

Keywords: Direct Drive, Linear Generator, Power Takeoff

1 Nomenclature

B_{rem} = Remnant flux density of magnet used
 H_m = Field intensity of magnet
 S_{airgap} = reluctance of airgap, including magnets
 $S_{back\ steel}$ = reluctance of flux path through module back
 S_{module} = reluctance of flux path from module to module
 μ_0 = permeability of free space
 μ_r = relative permeability of permanent magnet material

2 Introduction

The nature of wave and tidal renewable energy resources places new demands on power takeoff technology. A variable power input requires a generator that is at least as efficient at part load as it is at full load. Meanwhile the power is typically delivered to the wave energy converter or rotor of a tidal device in a large force moving at a low speed, unsuitable for conventional high speed and low force generators. The use of such generators requires a gearbox, bringing additional risks of failure and requirements of maintenance. The extreme cost penalties of work on an

installed device due to the operating environment and unpredictable access suggest that a device with fewest stages in its power takeoff will result in a lower overall cost of energy. The direct drive concept, where electrical power takeoff is coupled as closely as possible to the energy extraction mechanism has been shown to be possible at commercial scale in both Wave [1] and Tidal [2] energy. However its adoption has been limited due to the size, weight and cost of a suitable generator.

The Institute for Energy Systems at the University of Edinburgh aims to produce a lightweight, low cost, easy to assemble generator solution for a variety of renewable energy applications. This paper presents the background to this work and details the projects that have taken place to date and ongoing work.

3 C-GEN Generator Technology

The C-GEN is a modular air cored permanent magnet generator with a flux path that allows flux carrying material also react the attractive magnetic forces within the generator. This leads to overall mass and cost savings when compared to a conventional layout.

Permanent magnet Generators (PMG) have less fixed loss mechanisms than other generator types and thus are more efficient at part load. A Garrad Hassan market review [3] suggests that an increase in energy conversion of between 3 and 4% could be expected when a PMG is used compared to a conventional machine in a wind energy application. The advantage in other renewable energy environments would depend strongly on the device and variation of the resource at the location.

An air cored machine has no iron in its windings which greatly reduces difficulty in assembly (as there is no attractive force between stator and rotor) and the loads experienced by the bearings. The lack of iron in the windings increases the airgap size and therefore reduces the airgap flux for a given magnet. However in many applications the increase in cost of magnets and

frame size for a given power output will be outweighed by the reduction in construction cost and structural mass.

The advantages of a new generator must be clearly demonstrated if tidal and wave energy developers are to have the confidence to adopt new generating technologies. This paper is an outline of the work accomplished so far in the development of C-GEN and the work planned and in progress.

3.1 Layout of a C-GEN generator

The main features of a C-GEN machine are covered in this section. A more detailed introduction to the C-GEN concept was presented in the previous EWTEC conference [4], detailed electromagnetic and structural modelling can be found in a paper presented to the Power Electronics Machines and Drives conference in 2008[5].

The C-GEN machine takes its name from the core layout of a rotary generator. The core material is C shaped with the magnets on the limbs of the C. In this arrangement the main load on the structure is the attractive force between the magnets which is reacted by the shape of the C. In a linear generator the C can be closed increasing the rigidity of the structure and providing an additional flux path.

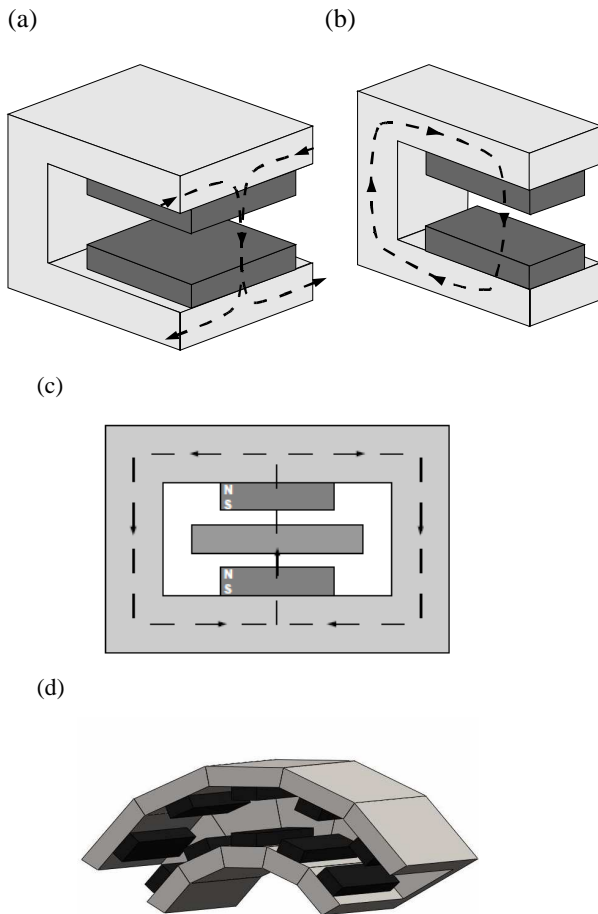

Figure 1: C-GEN magnetic flux paths, (a) module to module flux path, (b) module back flux path and (c) linear generator back flux path (d) assembled rotary c-gen modules

The flux path of a C-GEN machine is shown in fig. 1. The magnetic flux passes across the airgap and flows both from core module to core module or around the C shaped back iron. This gives a 3 dimensional flux path, modelled by the reluctance network in fig. 2.

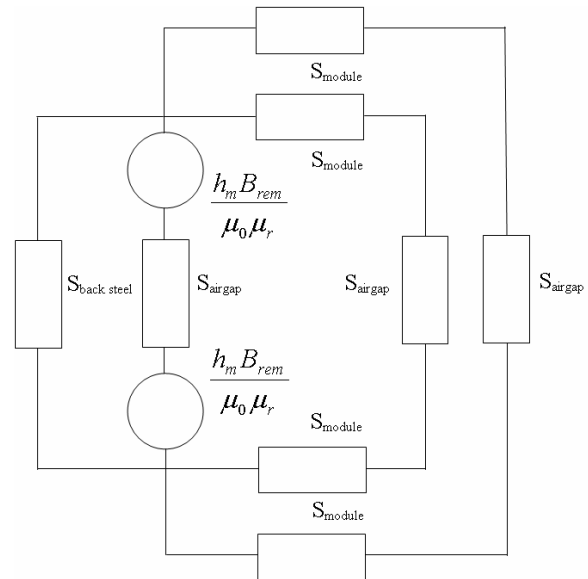

Figure 2: Reluctance network for a C-Core

The reluctances are calculated from the chosen geometry of the machine and materials data. The flux crossing the airgap is initially found from the above reluctance network and then checked using finite element modelling.

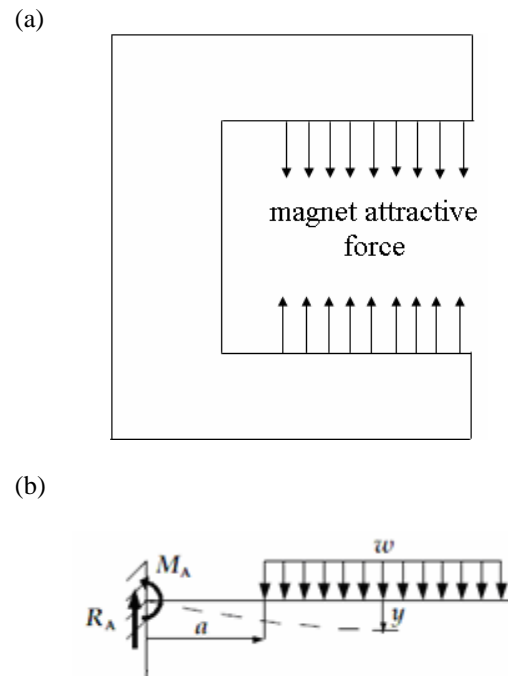

Figure 3: (a) Magnet attractive force acting on core of a C-GEN module

(b) Structural model of a single limb of the C-GEN module

Fig. 3 shows the primary load on the C-GEN structure, due to the attractive forces of the magnets. This is modelled as a distributed load. With a sufficiently stiff web section the equations for a fixed end beam will model the resulting deflection. Otherwise a more complex model must be used. The greatest area required by either electromagnetic or structural modelling is used to size the back iron.

Thermal modelling is carried out by using appropriate correlations, geometry and measured data from existing prototypes to create a thermal resistance network. The rotary and linear machines described in this paper require very different thermal networks and measurement work is ongoing for both types of generator.

3.2 Practical design

The prototypes detailed in section 4 were developed using integrated electromagnetic, structural and thermal design. The main elements of the generator can be mapped out using analytical techniques. These analytical techniques are highly amenable to automated optimisation routines and a genetic algorithm based tool is under development within the group.

CAD is used to convert the analytical model into a dimensioned 3D model for finite element modelling or fabrication. Once a rough layout of generator elements is agreed upon the link between the analytical model and CAD can be automated. This accelerates the design process in the later stages as an element of feedback naturally exists between fabrication requirements, modelling results and the analytical model. Once a design is found that satisfies the specification while being easy to assemble and cheap, it can be constructed.

The increasing integration of modelling and design allows generators to be tailored to the varying requirements of different renewable energy resources. The modular nature of C-GEN combined with the simplicity of components and assembly lends itself to the production of application specific generators even in relatively low numbers.

4 Prototype Development

3.1 20kW Prototype

A rotary generator prototype capable of producing 20kW at 100rpm was designed by Edinburgh University and constructed by Fountain Design Ltd with funding from Scottish Enterprise.

The magnets are mounted on C-Core elements making up the rotor of the generator. The back iron is made up of trapezoidal sections of mild steel in three sections and bolted together.



Figure 4: Assembly of stator and rotor with an engine hoist

The windings are concentrated coils wound around a former and encased in resin for structural strength. They make up the stator of the machine and are cantilevered into the C-Cores as there is no force between winding and magnet. Hence the assembly of the stator and rotor could be carried out with the engine hoist shown in fig 4.

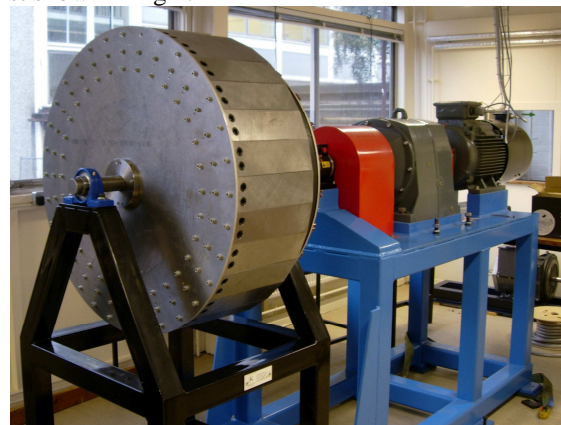

Figure 5: 20kW C-GEN prototype on test rig

The generator was mounted on a specially designed test rig (fig 5) in the University's machines lab. An induction generator with a reduction gearbox drives the prototype through a torque transducer. This allowed accurate measurements of the generator performance to be made. The efficiency of the generator at half to rated speed is shown in fig 6.

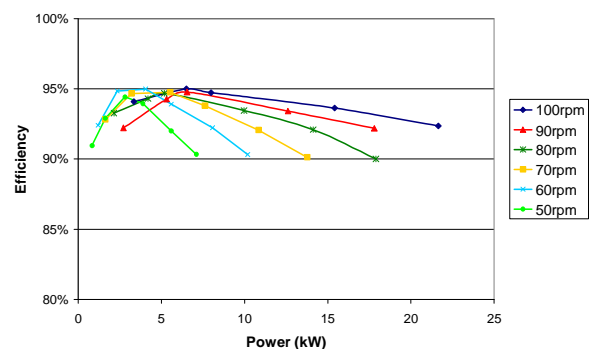

Figure 6: Measured efficiency of 20kW C-GEN prototype

The peak efficiency of the generator is found between low load and half load, which can be advantageous for renewable resources.

4.2 15kW Prototype

The second generation of rotary C-GEN machine is designed to fit a Proven 15kW wind turbine. This required a larger radius of generator and a shorter axial length than the previous machine. The project incorporated many improvements from the previous version. One of the major improvements was using hot forging to achieve the necessary core shape from a single piece of steel. The difference in the produced core segment can be seen by comparing figs 5 & 7. The design changes allowed the mass of the generator to reduce from 950kg for the 20kW generator to around 400kg for the 15kW generator.



Figure 7: 15kW C-GEN prototype on test at Edinburgh University



Figure 8: Installation of 15kW C-GEN prototype at Myres Hill wind farm

The 15kW prototype was integrated into a small-scale wind turbine (fig 8) in order to demonstrate the C-GEN technology operating in a real-life environment. Field trials are being carried out at the Myres Hill wind turbine test facility in order to assess the long-term performance of the generator, both electrically and mechanically. Commissioning of the wind turbine

system, which includes a power converter and control system to generate power into electricity network, is currently in progress. Initial results from the 15 kW C-GEN generating into a resistive load as shown in fig 9.

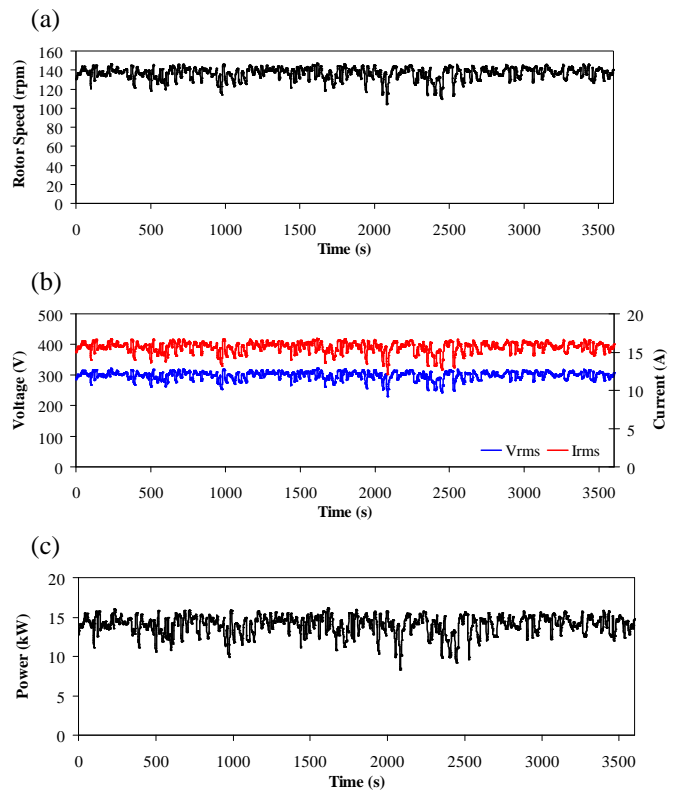

Figure 9: Data from initial Myres Hill tests (a) Rotor speed, (b) generator RMS voltage and current, and (c) 3-phase power

While the C-Gen generator can operate on a small scale wind turbine, it is in larger applications where the primary benefits of reduced structural mass and simplified construction are fully realized. Further prototype development of increased scale must be made before a direct comparison of measured performance can be drawn for a suitable turbine.

4.3 Application to tidal energy

The rotary generator prototypes were aimed at small scale wind energy as a site and device was readily available. The results and experience from the previous prototypes give confidence in the technology and the design tools. This experience is crucial for the design of C-GEN machines for the marine environment where access is limited and reliability is all-important. The application of the C-GEN technology to tidal generation would require the identification of a device and flow regime.

The SeaGen fact sheet [6] was used to identify one possible application of a scaled up C-GEN rotary generator. The generator would be capable of converting 600kW at 14.3rpm and would have limits placed on its outer diameter so it does not extend much beyond the rotor hub of the turbine.

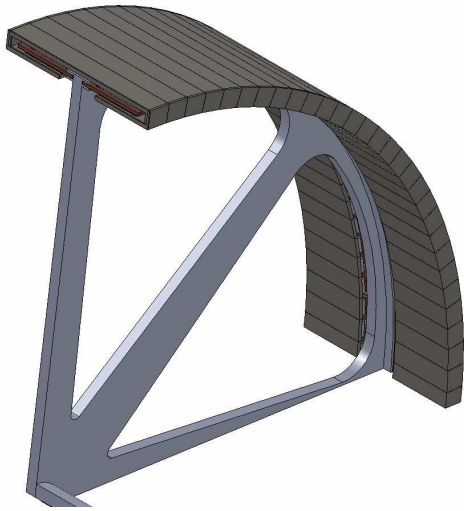

Figure 10: Quarter section of a double sided C-GEN machine

Diameter	3	m
Length	1.1	m
Weight	8184	kg

Table 1: Major dimensions of double sided 600kW generator

An outline design for this application was created using an optimisation algorithm and analytical design techniques. The dimensions of the resulting generator are given in table 1. This generator would be a double-sided rotary C-Core machine (fig. 10) with each side producing 300kW. This is one possible adaption to the relatively small rotor-size for a given power output found in tidal energy. Any increase in hub diameter due to the power takeoff will decrease the energy capture. This arrangement allows direct power takeoff to take place at a low airgap diameter of 3 meters for this power level. An alternative C-GEN design would use a gearbox with a much lower ratio than the current 70:1 speed increase and provide low speed, not direct drive power takeoff.

4.4 Linear Generator Prototype

Power takeoff from wave power often requires power conversion from a linear motion. Hence, direct drive power takeoff requires a linear generator. A small prototype was assembled to demonstrate C-GEN in this form. The original prototype used an overlapping winding (fig 11) as a stator, supported at both ends. The core sections were driven past the windings on a linear guide by a crank and arm mechanism. The resulting voltage waveform is shown in fig 12. This demonstrator is currently being converted into a linear bearing test bed.

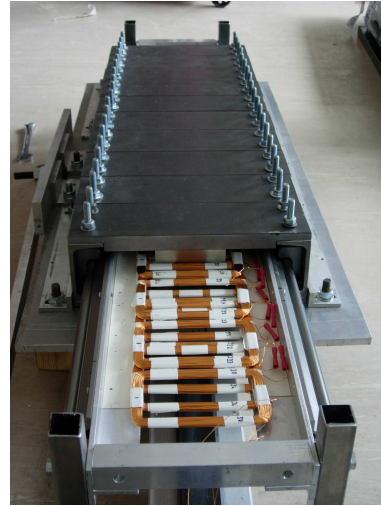

Figure 11: C-GEN Linear Generator with overlapping coils

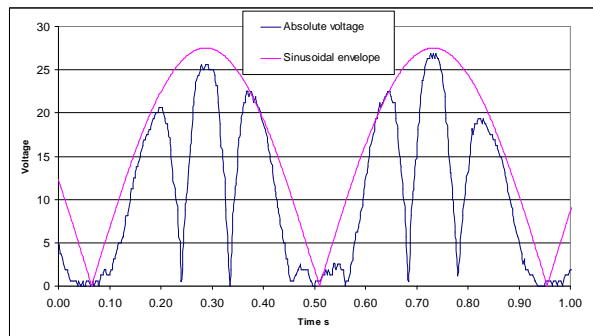

Figure 12: Single phase voltage waveform from linear generator with translator peak velocity 0.84m/s

Linear bearings capable of a long life in a harsh environment with long maintenance intervals remain a significant issue for a marine linear generator. Studies are being undertaken at the University of Edinburgh and a possible solution for an air-cored machine was found to be a composite bearing. The need to measure the performance of such a bearing in this application created a requirement for a bearing test rig capable of operating dry and flooded with vertical translator motion.

A new stator using concentrated coils was designed for the flooded test rig. A comparative study of air-cored windings for linear permanent magnet machines was carried out by Kamper [7]. It was concluded that if the endwindings were taken into account a concentrated coil could produce more thrust per watt of copper loss and would therefore make a more efficient machine. There could also be a reduction of copper mass in a concentrated coil winding along with simplified construction.

The new coil block was constructed by Fountain Design Ltd and delivered as a single watertight component. It is shown ready for natural convection tests in fig 13.

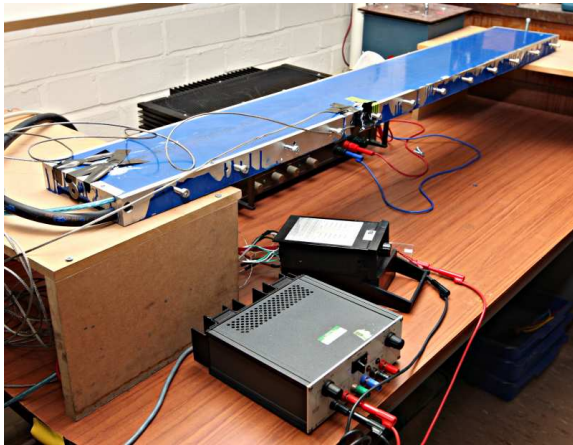

Figure 13: Submersible coil block on thermal test

Thermal tests were carried out on the coil block to calibrate future thermal models. Thermocouples in the windings allowed measurements of steady state temperature to be made for different alignments of the coil block. Results showed that if the active length of the coils was orientated vertically there is a 14% increase in natural convection heat transfer coefficient from the surface.

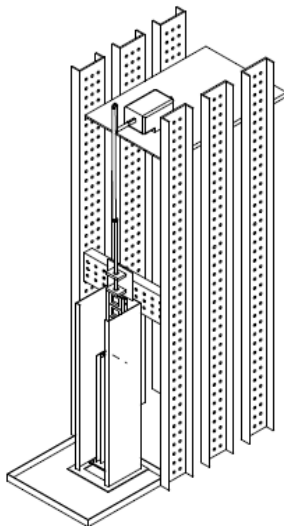

Figure 14: Layout of vertical test rig

The vertical axis test rig (fig 14) is being constructed at the time of writing. The linear generator will be entirely enclosed within a bath that can be filled with water. This work will provide operational experience with a flooded linear generator, at least partially applicable to a flooded rotary generator. It will also allow an assessment of bearing wear in this alignment with and without water being present.

5 Future Development

5.1 50kW Linear Generator

Work leading to the production and testing of a linear generator prototype is underway at the University of Edinburgh in partnership with Fountain Design and TUV NEL. The project is funded by the

Carbon Trust as part of the Marine Accelerator Programme, Strand B.

The project specification calls for a peak power of 50kW at 2m/s with a 2m stroke. The generator will be mounted on a hydraulic test rig at TUV NEL for testing with sinusoidal and non-sinusoidal power input. The size of this generator design is illustrated in fig 15 with the translator at its limit of extension.

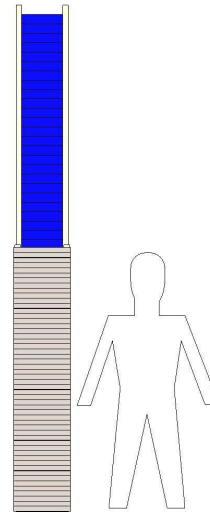

Figure 15: 50kW linear generator with outline of man for scale, translator is blue, stator is grey

There are production challenges associated with creating a 4m length of the translator in a relatively lightweight generator. The construction of a suitable translator requires a modular design with solid electrical connections, a task being undertaken by Fountain Design Ltd.

A basic layout was created and dimensioned to meet the specifications; this has since been enhanced by considering a wide range of solutions and picking the most suitable with consideration of efficiency, cost & mass. The layout was then been passed to Fountain Design for input on of construction of the generator. As a design moves closer to the production stage it is important that the effect of design changes can be quickly assessed as in the C-GEN layout the performance of the generator is linked to the structure. Hence the integrated design practice mentioned in 3.2 is valuable.

The linear generator will be ready for testing at TUV NEL in early 2010 where the performance of the generator will be measured at full, part and overload for sinusoidal and random displacements.

5.2 npower juice project

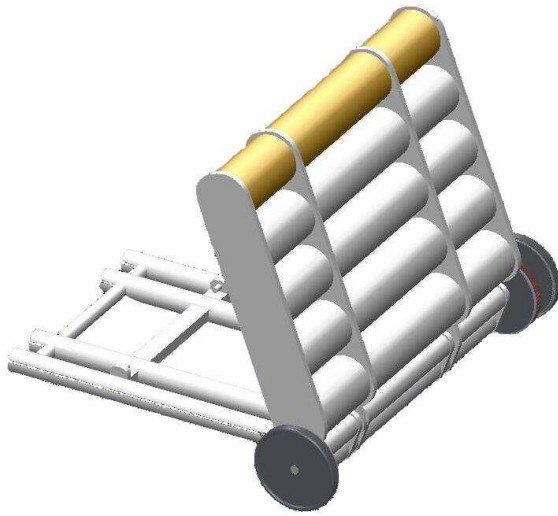

Figure 16: Possible application of rotary generators to Aquamarine Power Oyster device

npower juice has funded a 12 month feasibility study of the C-GEN concept on four different renewable energy converters. A suitable C-GEN design will be found for each and the advantages of using a direct drive system in each application assessed. The project partners are Aquamarine Power, whose Oyster device is shown with a possible C-GEN solution in fig 16, Scot Renewables, Marine Current Turbines and AWS Ocean Energy.

4.3 Larger generators

A full scale generator for a renewable energy application will be the outcome of this work. The ultimate size and layout of this generator will depend on the resource and power capture device. As part of the work on a wind power demonstrator, predictions were made for generators up to 2MW and compared to two commercially available generators. A comparison of mass for a given power from this study is shown in fig 17.

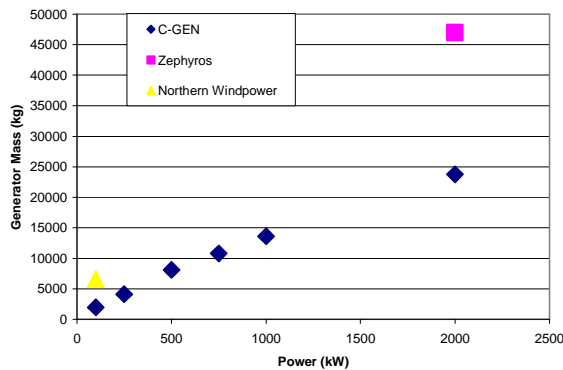

Figure 17: Scaling of C-GEN compared to conventional generators

The scaling of direct drive generators for wind power was investigated by McDonald in [8]. It was

shown that the active mass of a rotary C-GEN generator follows the scaling laws of a conventional machine. The power per structural mass of C-GEN scales as equation 1:

$$\frac{P}{m_{\text{str}}} \propto P^{0.56} \quad (1)$$

This compares favourably to the scaling predicted for conventional permanent magnet generators.

$$\frac{P}{m_{\text{str}}} \propto P^{-0.5} \quad (2)$$

Hence when the total mass of a generator is taken into account, the C-GEN will be considerably lighter. Results in fig. 16 show a 50% reduction.

For some marine applications, weight is not the primary deciding factor. C-GEN's advantage in this case is the reduction in construction cost of the generator due to the reduction in attractive forces and simple modular design. As no generators directly applicable to bulk power tidal or wave energy converters have been constructed this saving has not yet been quantified.

A large linear generator will be designed as part of the Carbon Trust project for use in a full scale wave device and the scaling of C-GEN in that application examined.

6 Conclusion

The C-GEN direct drive generator is particularly suitable for marine renewables as it removes steps from the power conversion process without the cost or mass of a conventional direct drive generator. The prototypes are in their second generation with the main emphasis of development so far being wind energy. This is a more accessible environment suitable for development work. A small linear demonstrator has been created and is being adapted to study one of the most important problems in direct drive wave power takeoff. A larger linear prototype is being designed and a feasibility study directly applicable for marine renewables is underway.

Acknowledgements

The work included in this paper was funded by Scottish Enterprise, The Carbon Trust, the Engineering and Physical Sciences Research Council and NPower Juice. It has been conducted in partnership with Fountain Designs Ltd, Proven Energy and TUV NEL. We also acknowledge the support from the Scottish Funding Council for the Joint Research Institute with the Heriot-Watt University which is a part of the Edinburgh Research Partnership in Engineering and Mathematics (ERPem).

References

- [1] Polinder H, Damen M, Gardner F, Linear PM Generator System for Wave Energy Conversion in the AWS, *Proceedings of the International Conference on Electrical machines*, August 2000
- [2] Open Hydro, *Technology: Open Centre Turbine*, <http://www.openhydro.com/techOCT.html> , accessed April 2009
- [3] Garrad Hassan, *Phase 2 Market Review, Lightweight Direct Drive Generator* October 2006
- [4] Mueller M, McDonald A, Ochije K, Jeffrey J, A Novel Lightweight Permanent Magnet Generator for Direct Drive Power Take Off in Marine Renewable Energy Converters, *7th European Wave and Tidal Energy Conference*, September 2007
- [5] McDonald A, Mueller M, Jeffrey J, Development of a Novel Permanent Magnet Linear Generator Topology for Direct-Drive Wave Energy Converters, *Proceedings of the IET Conference on Power Electronics, Machines and Drives*, April 2008
- [6] Montague R, Marine Current Turbines Ltd, *The Seagen Turbine* <http://www.seageneration.co.uk/downloads/recent/General%20Documents/Seagen%20Facts%20EXTERNAL%202.pdf>, November 2008, accessed April 2009
- [7] Kamper M, Comparison of Linear Permanent Magnet Machine with Overlapping and Non-Overlapping Air-Cored Stator Windings, *Proceedings of the IET Conference on Power Electronics, Machines and Drives*, April 2008
- [8] A.S. McDonald, *Structural analysis of low speed, high torque electrical generators for direct drive renewable energy converters*, Ph.D. dissertation, School of Engineering & Electronics, University of Edinburgh, February 2008