



DIGITAL ACCESS TO SCHOLARSHIP AT HARVARD

Negation and Functional Projections in Early Grammar

The Harvard community has made this article openly available.
[Please share](#) how this access benefits you. Your story matters.

Citation	Deprez, Viviane and Amy Pierce. 1993. Negation and Functional Projections in Early Grammar. <i>Linguistic Inquiry</i> 24, no. 1: 25-67.
Published Version	http://www.jstor.org/stable/4178801
Accessed	February 17, 2015 5:19:20 PM EST
Citable Link	http://nrs.harvard.edu/urn-3:HUL.InstRepos:2886297
Terms of Use	This article was downloaded from Harvard University's DASH repository, and is made available under the terms and conditions applicable to Other Posted Material, as set forth at http://nrs.harvard.edu/urn-3:HUL.InstRepos:dash.current.terms-of-use#LAA

(Article begins on next page)

Negation and Functional Projections in Early Grammar

1 Background and Predictions

This article has two main concerns. On the one hand, we show that functional projections play a role in the very early stages of syntactic development. On the other, we argue that child language data provide strong support for a particular model of the grammar, one adopted on independent grounds in the principles-and-parameters framework (Chomsky 1981, 1986). This theoretical model includes the VP-internal subject hypothesis, as well as the hypothesis that inflectional morphology is part of the syntax and determines the parametric options of verb movement. Looking at English, French, German, and Swedish acquisition data, we find systematic error in the placement of subjects alongside systematic absence of error in the placement of negation. Errors in subject placement are expected if subjects are indeed generated VP-internally and if the option to leave them in this position is characteristic of the early grammar. Correct placement of negation with respect to the verb is expected if the V-to-I/I-to-V parameter is set soon after the onset of grammatical development. In addition to providing support for the relevant theoretical hypotheses, our analysis challenges the view that the so-called telegraphic nature of early speech reflects a phase during which the child's grammar lacks functional projections. The early positioning of subjects, negatives, and verbs reveals knowledge of inflectional structure and, therefore, access to functional projections.

1.1 Empirical Background

In a ground-breaking study, Bellugi and her colleagues observed that the early negative sentences of English child language take the form of a negative element followed by the

Authors are listed in alphabetical order. This research was partially supported by an HRRF grant from Rutgers University to Déprez and by an NRSA postdoctoral fellowship (HD07380-02) to Pierce while at the University of Pennsylvania. Earlier versions of this article were presented at the Fifteenth Annual Boston University Conference on Language Development (October, 1990), the New Jersey Syntax Circle (March, 1991), and the 1991 GLOW Workshop on syntax acquisition, Leiden University. We thank the audiences at those events, Ken Wexler, and two anonymous reviewers for their comments. All remaining errors are ours.

sentence nucleus (Brown and Bellugi 1964, Klima and Bellugi 1966, Bellugi 1967). Some noted examples from the three children she studied are shown in (1).¹

(1) *Examples from Bellugi's (1967) data*

- | | |
|-------------------------|-------------------------------------|
| a. Not have coffee. | e. No the sun shining. |
| b. No singing song. | f. No I see truck. |
| c. Not write this book. | g. Not Fraser read it. |
| d. No eating that one. | h. No Mommy giving baby Sarah milk. |

Absent from this early stage, according to Klima and Bellugi (1966), are utterances in which the negative element occurs sentence-medially. Whereas subject NPs are often dropped in early language, overt subjects—when they do occur—are positioned to the right of the negative, as the sentences in (1e–h) show.

By providing the context in which the utterance occurs, Brown and Bellugi (1964) illustrated that the sentence in (1f), for instance, was intended to mean *I don't see the truck*. That, at least, was how the child's mother interpreted the utterance during conversation, as shown in (2).

(2) *Context of utterance of (1f)*

- Mother: Did you see the truck?
 Child: **No I see truck.**
 Mother: No, you didn't see it? There goes one.

In other words, the child's negative is understood as an instance of sentential negation, and not as an instance of *anaphoric* negation, in which the negative element negates a prior utterance. As an anaphoric negative, the sentence (1f) would, with the exception of the missing determiner, be considered grammatical and would be interpreted to mean *No, in fact I did see the truck*. As the *nonanaphoric* negatives they appear to be, however, utterances such as those in (1e–h) are not grammatical in adult English.

Klima and Bellugi (1966) argued that these errors in negative placement reflected the young child's inability to carry out a transformation that moves the negative element rightward, from a sentence-peripheral position to a sentence-internal one. It was assumed that the position of the negative marker in the child's grammar reflected the D-Structure of adult grammar. When, at a later point, the child produced sentences with subjects to the left of the negative, it was inferred that he or she could employ the negation-lowering transformation due to a developmental increase in ability to handle transformational complexity.²

In contrast to this approach, we maintain here that the sentence-initial negative is situated in a sentence-internal, rather than sentence-external, position. Based on our

¹ These data are also available on-line through the CHILDES data base (Brown 1973, MacWhinney and Snow 1985).

² Note that Neg-lowering, which is no longer postulated, would constitute a violation of the Empty Category Principle in current syntactic theory.

analysis of the cross-linguistic data, we affirm that negation is situated in the same position in both child and adult grammars. But, following Pollock (1989) and others, we assume that negation forms part of the sentence's inflectional projections. On this view, it is generated below IP and above VP. Accordingly, children who produce sentences like those in (1e-h) are not failing to lower the negative. Rather, they are sometimes failing to raise the subject from VP-internal position to a higher Specifier position.

In section 1.2 we outline our theoretical assumptions, and in section 1.3 we describe the resulting predictions for the acquisition of negation in English, French, and German. In section 2 we survey the cross-linguistic developmental data. Not only are certain predictions concerning the acquisition of negation confirmed, but other phenomena in the cross-linguistic data are found to accord with our expectations. These include, but are not limited to, the well-known null subject property of early grammar, the largely unexplored finding of postverbal subjects in French child language, and the as yet unexplained facts about the acquisition of subject-Aux inversion in English. The acquisition facts, we maintain, constitute evidence for the VP-internal subject hypothesis, parametric variation in the movement of the verb to Infl, and a Case assignment parameter. They also show that functional projections, verb movement, and the Case Filter play a role in the very early grammar. We are thereby arguing against the view that the Case Filter and functional projections undergo maturation, or are otherwise absent during an initial stage (cf. Guilfoyle and Noonan 1988, Aldridge 1988, Kazman 1988, 1990, Bloom 1988, Lebeaux 1988, Platzack 1990, Radford 1990). As spelled out by Radford (1990), this school of thought maintains that all constituents in pre-2-year-old language have a "purely lexical category status" (p. 47). In other words, children under 24 months of age are characterized as lacking Det, Comp, Infl, and Case systems. Although items having Det, Comp, Infl, or Case-marked status in the mature language often occur in immature speech, they are argued not to be grammatically represented until the point at which they are used productively. On this view, the ability to form functional or nonthematic structures is assumed to mature. According to Radford (1990), one testable prediction resulting from this approach is "that we should expect to find broadly *parallel growth* in the various functional and nonthematic structures which the child acquires" (p. 290). The findings described below challenge this position on two fronts. First, there is evidence that the Infl system is available from the start of syntactic development, prior to 24 months of age. Second, as discussed in section 3, the acquisition of the Comp system appears to be delayed relative to that of the Infl system, contrary to the expectation of parallel growth in all functional systems.

1.2 Theoretical Background

We make four assumptions concerning the grammar, consistent with recent theoretical proposals. These hypotheses are listed in (3).

(3) *Grammatical assumptions*

- a. Subjects are internal to the verb phrase at D-Structure (Kitagawa 1986, Contreras 1987, Koopman and Sportiche 1988).
- b. Nominative Case may be assigned under government by Infl (Koopman and Sportiche 1988, Sportiche 1988, Huang 1989).
- c. Negation heads its own projection under IP (Pollock 1989, Laka 1989, Zanuttini 1989).
- d. Inflectional affixes are attached to the verb via movement of the verb (French, German) or of the affix (English) in syntax (Emonds 1978, Pollock 1989).

Turning to the first assumption, it has been proposed that the sentential subject is generated within the maximal projection of the verb, as the sister of an intermediate verbal projection (Kuroda 1988, Kitagawa 1986, Contreras 1987, Fukui and Speas 1986, Sportiche 1988, Koopman and Sportiche 1988, among others). According to this theory, the D-Structure representation of the basic English or French sentence is as in (4a), and that of the basic German sentence is as in (4b).³

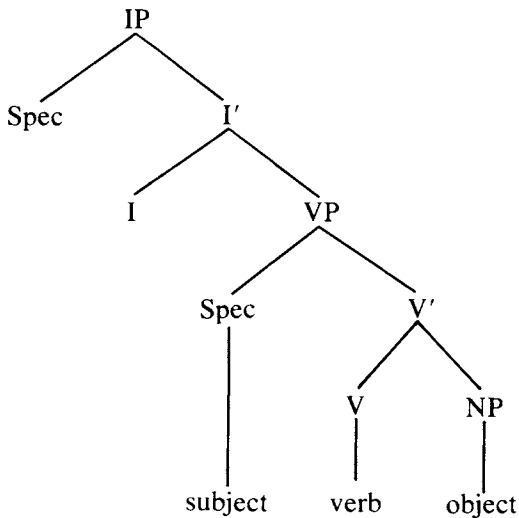
(4) a. *English/French D-Structure*

³ Koopman and Sportiche (1988) assume a somewhat different structure, in which Infl is the sister of V', the small clause projection of V.

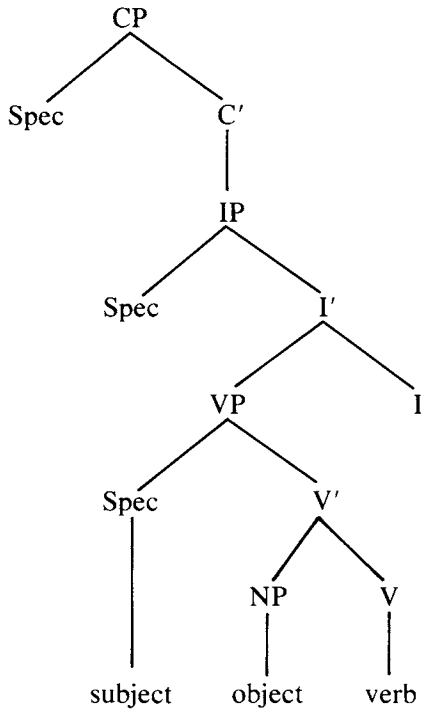
b. *German D-Structure*

With respect to German, observe in (4b) that, in parallel with the headedness of verbal projections, we are assuming that Infl is final and therefore situated on the right (Vikner and Schwartz 1988, Déprez 1989a, Vikner 1990).

It is argued that subjects in languages like French and English normally fail to be assigned nominative Case in the VP-internal position (Koopman and Sportiche 1988). Consequently, they must raise to another position, [Spec,IP], where nominative Case is assigned via the Spec-head relation.

The second assumption concerns the parametric option to assign nominative Case under government. According to Koopman and Sportiche (1988), the underlying VP-internal subject structure conforms to the configuration for nominative Case assignment in languages without obligatory subject raising. In Koopman and Sportiche's framework and elsewhere, Infl can head-govern the maximal projection of the verb and its Specifier and thereby assign Case to the VP-internal subject. When nominative Case is assigned under government, the subject is not forced to raise. Subject NPs in some Romance languages (for instance, Spanish) may be assigned Case directly, within the VP, and are thus licensed to remain in situ (Contreras 1987, Bonet 1990, Déprez 1989b). Within this framework, the phenomenon of so-called free inversion in languages like Spanish may

be analyzed as involving VP-internal subjects that do not raise, along with either verb raising or a lack of fixed ordering of constituents under VP. As we show below, the preponderance of postverbal subjects found in French child language are readily explained in this fashion. In addition, canonical government by Infl serves to license *pro* in VP-internal subject position (see also Adams 1987). We maintain here that nominative Case assignment under government by Infl is an initial option in the child's grammar, leading to both overt and empty VP-internal subjects.⁴

Our third assumption is that there exists a NegP. Accordingly, we assume the basic negative structures shown in (5a) for English and French, and in (5b) for German.

(5) a. *English/French negation*

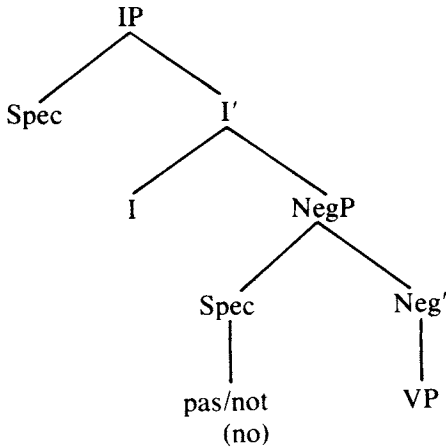

b. *German negation*

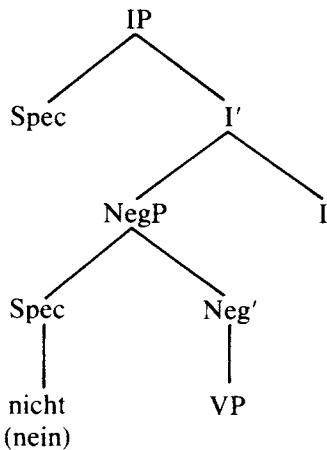

⁴ In fact, we claim below that nominative Case assignment under government and the licensing of *pro* appear, upon closer examination, to be dissociated in the English developmental data. Both, however, reduce to Infl-government.

With Pollock (1989), Zanuttini (1989), and others, we maintain that *pas* is the French counterpart of English *not* and German *nicht*. As in English and German, the French marker of negation occurs below the projection of Infl and above the VP. We assume that the overt negative element occurs to the left of the VP. This presupposes that we are not taking the negative element *nicht* (or *nein* in the language of some children) to be a head in German.⁵ The issue of whether certain overt markers of negation are or are not heads is at present controversial. Pollock (1989) has proposed that the negation projection in French is comprised of a head *ne*, realized even when empty, and a Specifier *pas*, which must be overtly represented. Zanuttini (1989) has also proposed that *ne* is the head of NegP but argues that *pas* is a VP adjunct, as are *nicht* and *not*.⁶ While remaining uncommitted with respect to the precise formulation of NegP, we assume that the relevant negatives occur in a nonhead position to the left of the VP, and that their position is fixed at S-Structure.

The fourth background assumption concerns the distinction between English and French in terms of syntactic mechanisms for inflectional affixation. We assume, following Emonds (1978) and others, that all French verbs raise to Infl in tensed clauses to bind tense and agreement morphology at S-Structure. German verbs also undergo raising, first to Infl, which we assume to be final in German, and then on to Comp (Den Besten 1977, Vikner and Schwartz 1988, among others). In English, however, inflectional affixes lower onto the verb, the only exception being the auxiliary; modals are generated in Infl, and *be* and auxiliary *have* raise to Infl along the lines of tensed verbs in French.

A major source of evidence for this French-English distinction is the differing placement of negation and VP-adverbs in the two languages. In French the negative marker and certain adverbs surface in postverbal position as a result of verb raising, whereas in English their equivalents surface in preverbal position. The by now familiar examples of the type in (6) and (7) illustrate this contrast.

(6) *Comparative French-English order of verbs and VP-adverbs*

- a. Ce chat chasse *souvent* les oiseaux.
- b. This cat *often* chases birds.

(7) *Comparative French-English order of verbs and negatives*

- a. Ce chat (ne) chasse *pas* les chiens.
- b. This cat does *not* chase dogs.

1.3 Predictions for Acquisition

We turn now to the resulting expectations for child language. Note that if functional categories including Infl are present in the early grammar of the child, as we claim, and if the option to assign nominative Case under government to the VP-internal subject is

⁵ See footnote 18 for discussion of the child's choice of negative marker.

⁶ See Zanuttini 1989 for arguments based on the behavior of negative concord and the licensing of negative polarity items.

available, then we have the following prediction: There may be a stage in syntactic development when the underlying VP-internal position of the subject is transparent, a stage prior to obligatory or appropriate subject raising in the languages at hand.

Consider the variety of constituent orderings made possible by the theoretical hypotheses summarized above. Table 1 displays expected word order in negative constructions, contingent upon certain conditions. These conditions, which are intended to describe possible characteristics of child grammar paralleling parametric options made available by Universal Grammar (UG), are as follows: whether or not the subject raises, whether or not the verb moves to Infl, whether or not the order of constituents under VP is fixed as subject-initial, and whether or not verb movement to Comp is instantiated.

Note that table 1 is not intended to define developmental stages in acquisition, according to which only one construction type might be found at a time. Rather, the consistent use of a given construction type is taken to signal the availability or non-availability of requisite grammatical mechanisms. Moreover, a child's use of two or more construction types is taken to indicate that, in some cases, specific movement rules are available but only optionally accessed, an issue to which we return below.

Observe in table 1 that subjects should be positioned to the right of Neg if the VP-internal subject hypothesis holds and if children fail to raise the subject NP consistently. As we will show, such evidence clearly exists in the development of all three languages. An early setting of the verb movement parameter leads one to expect French-speaking children to display postverbal negation and postverbal subjects, as a consequence of verb raising. In contrast, English-speaking children are predicted not to display postverbal negation and subjects, because of the absence of main verb raising. Subjects and

Table 1

Predictions with respect to word order in negative sentences. (SR = subject raising; SV = subject-verb order at D-Structure; VS = possible verb-subject order at D-Structure)

<i>SR</i>	<i>V-to-I</i>		<i>V-to-C</i>	<i>English</i>	<i>French</i>	<i>German</i>
–	–	SV	–	Neg (S) V	Neg (S) V _{inf}	Neg (S) V _{inf}
–	–	VS	–	Neg V (S)	Neg V _{inf} (S)	Neg V _{inf} (S)
+	–		–	S Neg V	S Neg V _{inf}	S Neg V _{inf}
–	+	SV	–	Aux Neg (S) V	V _{fin} Neg (S)	Neg (S) V _{fin}
–	+	VS	–	Aux Neg V (S)	V _{fin} Neg (S)	Neg (S) V _{fin}
+	+		–	S Aux Neg V	S V _{fin} Neg	S Neg V _{fin}
+	+		+	Aux S Neg V	V SubjCl Neg	S V _{fin} Neg

negation should nevertheless be able to follow overt auxiliaries and modals, which occur in Infl, even in languages where main verb movement is precluded. Here again, we will show that this expectation is fulfilled, further demonstrating the early presence of the functional category Infl.

In German, where Infl is a right-branching head, movement of the verb to Infl is string-vacuous. In the absence of further movement of the verb to Comp, the main indication of V-to-I movement's existence is the sentence-final placement of finite verbs in utterances of three words or more. If, on the contrary, verb movement to Comp were mastered early on, we would expect to find postverbal subjects and negation in 2-year-old German. Although they are sometimes instantiated, these constructions are found to be used inconsistently at best. The lack of obligatory verb movement to Comp in German leads us to examine this type of movement from a cross-linguistic perspective. We will show that verb movement to Comp appears to "stabilize" later than verb movement to Infl in the acquisition of the three languages, as well as in that of Swedish. Similarly, the known facts about the acquisition of negation in German are consistent with the conclusions reached on the basis of our study of English and French development. We turn first to the English data.

2 Cross-Linguistic Evidence

2.1 *The English Evidence*

To clarify our predictions for English, there are two types of sentential negatives we expect young children to produce if they are failing to raise the subject NP consistently: (1) negatives in which the subject is positioned to the right of the negative marker, and (2) negatives in which the subject is omitted. Recall that null subjects are analyzed as VP-internal subjects in the adopted framework.

In our discussion of English here, we consider the output of three children represented in the CHILDES computerized data base (MacWhinney and Snow 1985). These include one of the children originally studied by Bellugi (1967), one of the children studied by Bloom (1970), and a third child whose negative utterances have not been analyzed previously.⁷ The child pseudonyms, ages examined, and original data sources are shown in (8).⁸

(8) *Sources of English data*

Eve	(Bellugi 1967, Brown 1973)	1-6-0 to 2-0-0
Nina	(Suppes, Smith, and Léveillé 1973)	1-11-2 to 2-3-0
Peter	(Bloom 1970)	1-11-2 to 2-3-3

⁷ We chose children who were first recorded at or before the age of 2 years. We considered data from the first recording to a point roughly two months after first use of the Neg-medial construction (where relevant first use was determined to be use of more than one such construction in a given transcript).

⁸ Ages are given in the form year-month-week.

For each child, we observed an early period in which subject-initial negatives were quite rare. During this period, children produced mainly null subject and subject-medial negatives, as illustrated in table 2. This was followed by a period in which subject-medial negation disappeared and subject-initial (i.e., Neg-medial) negatives were readily produced.

Table 2 depicts an early period in which Neg-initial negatives are common, and seemingly preferred. During this period, children generally produce null subject negatives and negatives with subjects to the right of the negative element. This is in line with Bellugi's (1967) characterization of the early period, although the evidence does not indicate that Neg-medial negatives are completely absent. If the hypothesis that negation forms part of the inflectional complex is correct, these data indicate that the young child's early grammar, in contrast to the adult grammar, manifests the option to leave the subject in a VP-internal position at S-Structure. Although we are not claiming that the child's grammar systematically excludes subject raising during this early period, we maintain that the subject NP can be Case-marked VP-internally and is therefore licensed to remain in VP-internal position.

(9) contains compelling subject-internal data from one child, Nina.

(9) *Nina: Some nonanaphoric negatives*

- a. No my play my puppet. Play my toys. (2-0-2)
- b. No Mommy doing. David turn. (2-0-2)
- c. No lamb have it. No lamb have it. (2-0-3)
- d. No lamb have a chair either. (2-0-3)
- e. No dog stay in the room. Don't dog stay in the room. (2-1-2)
- f. Don't Nina get up. (2-1-2)
- g. Never Mommy touch it. (2-1-2)
- h. No Leila have a turn. (2-1-3)
- i. Not man up here on him head. (2-2-1)

An examination of the conversational context in which these utterances occur suggests that each is an instance of nonanaphoric negation. That (9c) is not intended to mean "No, the lamb does have it" is illustrated by the mother-child dialogue in (10).

(10) *Context of utterances (9c-d)*

- Mother: Can you put it on the floor?
 Nina: **No have it, Mommy.**
 Mother: You don't want me to have it?
 Nina: **No. No. No lamb have it. No lamb have it.**
 Mother: You don't want the lamb to have it either.
 Nina: **No lamb have a chair either.**

Table 2
Early distribution of negatives in three English-speaking children

		<i>Neg-initial</i>	<i>Neg-medial</i>
Eve	18–21 months	12	2 (14%)
	22–24 months	17	41 (71%)
Peter	23–25 months	23	1 (4%)
	26–28 months	61	19 (24%)
Nina	23–25 months	36	0 (0%)
	26–28 months	50	49 (50%)

Similarly, (9b) most probably means that ‘‘Mommy’s not doing’’ (i.e., that it is not the mother’s turn), based on the dialogue in (11).

(11) *Context of utterance (9b)*

Mother: Let me try it. (*as mother takes the whistle*)

Nina: Yeah.

Mother: What’s mommy doing?

Nina: **No mommy doing. David turn.** (*as Nina brings whistle to David*)

Considering yet another example, the sequence in (9a) (*No my play my puppet. Play my toys.*) is uttered right after Nina has thrown her puppet on the floor. She then proceeds to take her toys off the shelf.

The option to leave the overt subject VP-internal is clearly an early phenomenon. In Nina’s case, 100% (17) of the negative utterances that occur in her speech sample at 25:2 are Neg-initial (meaning, either with null subjects or with subjects to the right of the negative marker). In the sample recorded weeks later, however, 50% of her negative utterances are Neg-initial: 15 out of 30 negative sentences contain a subject to the left of Neg.

During a relatively early stage, then, the child is expressing sentential negation with a construction that is never attested, with the intended meaning of denial or rejection, in the adult speech that serves as input. Nina is in fact producing many more instances of nonanaphoric than of anaphoric negation at this stage, by a factor of over two to one. We therefore have evidence for early use of Neg–S–V word order (see table 1). In accordance with the theoretical assumptions outlined above, we propose that the structure of child negatives like those in (1) and (9) is as shown in (12).

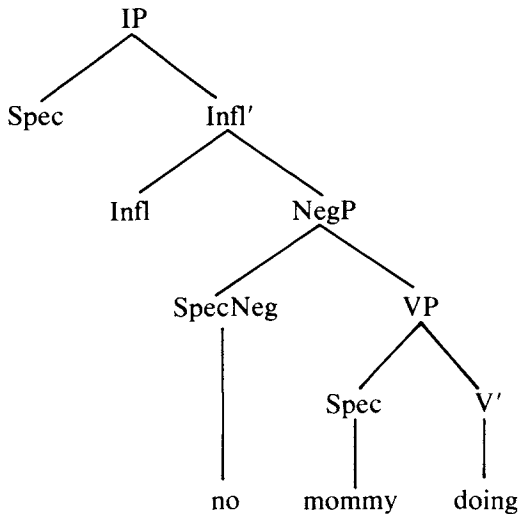
(12) *Syntactic structure of child utterance (9b)*

This analysis contrasts with the more common description of Neg-initial constructions in the child language literature, according to which the child's negative marker resides in Comp (e.g., Bloom 1970, Wode 1977). Although the Comp analysis appears to fit with Neg-initial data like those in (1) and (9), it fails to account for other known facts about the development of English negation. One indication that the child negator *no* is not in Comp is that *no*, like *not*, sometimes occupies noninitial position in young children's negative sentences. In (13) the negative *no* occurs in sentence-medial position.

(13) *Evidence that no is not in Comp*

- a. He no bite you.
- b. I no want envelope.
- c. I no taste them.

The fact that young children tend to use *no* in place of *not* has often been taken to show that they have a syntactically distinct form of negation and has been a key consideration in the Comp analysis. But examples like those in (13) show that the *no* form itself surfaces in non-Comp position.

Further evidence that *no* is not in Comp derives from the characteristic absence of certain predictable errors. (14) shows Neg to the left of the auxiliary verb, a structure that is generally not observed but would be predicted to occur if the child's negative were situated in Comp.

(14) *Unobserved errors: Further evidence that Neg is not in Comp*

- a. *No(t) can John leave./*No(t) John can leave.
 - b. *No(t) is Kitty sleeping./*No(t) Kitty is sleeping.
- i.e., *no(t) [_{IP} (subject) Infl [_{VP} (subject) V]]

At the same time that child utterances like those in (14) are not regularly found, negatives with auxiliaries in sentence-initial position are observed. At the early stage we are examining, these tend to involve contracted negative forms like that in (9f). Constructions with full auxiliaries occur somewhat later, as in the utterance *Why do not you want?*, produced by Eve at 2-3-0. Such evidence leaves no option but to assume that the position of negation in the child's grammar is identical to its position in the adult grammar (i.e., between Infl and the VP, not in Comp). Children's errors in subject placement therefore provide powerful support for the VP-internal subject hypothesis. They also show that Infl is represented in the very early grammar.

Another type of unobserved negation error suggests that the child has knowledge of the correct parameter setting for verb movement. If the English-speaking child knows that auxiliary verbs alone raise in the target language, we expect to find Aux-negation structures such as (9f). At the same time we do not expect errors of the type in (15), where negation follows a main verb.

- (15) a. *I fall not.
 b. *I bite not you.

In fact, such negatives are not observed. Furthermore, as shown by Stromswold (1990), children never confuse main verb *do* with the homophonous modal, with the result that sentences such as *I do not it* never arise. Nor, according to Stromswold, is there confusion between main verb and auxiliary verb usage of *have* and *be*.

Summarizing, this survey of English child language suggests that there is a shift over the course of development with respect to the preferred ordering of subjects and inflectional elements. This shift arguably reflects the transition from a pre-obligatory subject raising grammar to a more adult-like grammar of English, one that generally requires subject raising. With respect to negation, the data presented here provide evidence for a developmental stage in which Neg occurs sentence-initially as a result of the VP-internal position of the subject and the lack of main verb raising. Neg, then, is arguably situated in an IP-internal, rather than IP-external, position. We turn in the next section to the case of French, where main verb raising is observed in very early speech.

Important in terms of substantiating our analysis of early negatives is the co-occurrence of initial Neg constructions and other phenomena predicted by the model. That is, in order to demonstrate that initial negation in child language reflects the acquisition of a grammar conforming to (3), it is necessary to show that other constructions predicted by the model are prevalent at the same early stage. Related word order errors involving unraised subjects in sentences containing unaccusative verbs and auxiliaries are discussed below, in the context of the comparative cross-linguistic data. Another phenomenon corroborating this general picture is subject omission. However, omission of the subject in English child language appears to endure beyond the period of optional nonraising of the overt subject. Neg-initial utterances of the null subject variety are produced after overt VP-internal subjects stop being produced. Assuming, as we do, that null subjects are VP-internal subjects, how might this fact be reconciled with the

developmental change in placement of overt subjects? This finding in fact suggests a dissociation between nominative Case assignment under Infl government and the licensing of empty subjects. Before turning to the French data, we briefly consider the analysis of null subjects in English child language.

It is well known that children acquiring English pass through a prolonged stage in which they frequently drop the subject NP (Hyams 1986). Although an account of null subjects in child language is not our main concern here, we point out some of the consequences of our central assumptions. Note first that the null subject facts are readily explained in the adopted framework as resulting from the VP-internal position of subjects. According to Koopman and Sportiche (1988) and Adams (1987), a pro subject is licensed in VP-internal position when it is canonically governed by Infl. That Infl is indeed a governor in child language is suggested by the fact that it can assign Case to a VP-internal subject. However, as noted above, the observation that null subjects persist until about 2½ years of age (Hyams 1986) suggests a dissociation between nominative Case assignment via Infl government and the distribution of referential pro subjects in child language. Although Case assignment by Infl government may be excluded fairly early in the course of English acquisition (as indicated by the disappearance of Neg-subject sentences), Infl may still govern and license pro subjects, which arguably do not require Case (cf. the original formulation of the Case Filter (Chomsky 1981)), in VP-internal position. In effect, along the lines of actual raising verbs such as *seems*, Infl can be a governor without being a Case assigner.

Null subjects surface when two syntactic conditions, licensing and identification, are met (Rizzi 1986). We assume here that pro licensing is accomplished by canonical Infl head government. According to Jaeggli and Safir (1989), this condition is all that is required to permit nonreferential pro drop. Referential pro drop, on the other hand, requires that the identification condition be met. There are three distinct proposals concerning identification in the literature: agreement-based identification (Rizzi 1986, among others), control/anaphoric identification (Borer 1989, Huang 1989), and discourse-operator identification (Huang 1989). Although in somewhat differing ways, the first two proposals make crucial reference to the presence of Agr in Infl. There are essentially three cases to consider: (a) If the agreement morphology of a language is rich, then identification obtains automatically. (b) If agreement is absent, matrix null subjects and embedded null subjects are identified by distinct mechanisms, the embedded pro by a matrix argument (Huang 1989) (or by an abstract matrix agreement (Borer 1989)) and the matrix pro by a discourse operator or by pragmatic control. (c) Finally, if agreement is weak but nonetheless present, no identification is possible.

We suggest that referential null subjects in English child language are identified by what Huang refers to as pragmatic control.⁹ English lacks morphologically rich Agr.

⁹ The main distinction between discourse operator identification and pragmatic control is their differing predictions with respect to null objects. Discourse operator identification entails that subject drop and object drop are licensed and identified by exactly the same mechanisms. They should thus occur at the same time and show identical frequency. As shown by Bloom (1990), this does not appear to be correct for child language.

Furthermore, the full content of Agr does not appear to be acquired until roughly 2½ to 3 years of age (Brown 1973). It is therefore implausible to assume that Agr serves to identify the empty subject in English child language. As Infl gains ϕ -features in the course of English development, case (c) will apply, and identification of referential pro will be precluded. At the same time it is plausible that the onset of affix lowering in English and other languages that lack verb movement disrupts the licensing environment for pro subjects (Pierce 1989).¹⁰ This leads to the exclusion of even nonreferential null subjects in languages such as English. The ensuing prediction is that the acquisition of inflectional agreement morphology in English should coincide with the disappearance of null subjects. This correlation is substantiated in the literature on child pro drop (Hyams 1986, Guilfoyle 1986, Hyams and Jaeggli 1988). French, on the other hand, manifests both V-to-I movement and rich agreement, in the form of subject clitics. The conditions permitting null referential subjects are thus arguably met in both child and adult French.¹¹

2.2 *The French Evidence*

In our study of French negation, we examined transcribed, naturalistic data from four monolingual children. The data sources, child pseudonyms, and age ranges are given in (16).¹²

(16) *Sources of French data*

Daniel	(Lightbown 1977)	1-8-1 to 1-11-1
Grégoire	(Champaud)	1-9-2 to 2-1-3
Nathalie	(Lightbown 1977)	1-9-3 to 2-2-2
Philippe	(Suppes, Smith, and Léveillé 1973)	2-1-3 to 2-2-2

The English acquisition data surveyed in section 2.1 suggest that early grammar is characterized by the option to leave subjects in their VP-internal position and by an early setting of the verb movement parameter. If both of these findings are sustained, our predictions for early French are as follows. First, proper setting of the verb movement parameter in French entails that negation should occur in initial position (i.e., before the verb and the subject) only in untensed sentences, that is, only in contexts where V-to-I movement does not take place in the adult grammar. With tensed verbs, on the other hand, negation should occur postverbally. Second, the option to leave the subject in VP-internal position suggests that subjects will surface in postverbal positions as a

The frequency of object drop is significantly lower than that of subject drop (9% versus 50%). Although possibly due to general processing and pragmatic principles, as assumed by Bloom, this asymmetry suggests that subject and object drop may come under distinct licensing and identification conditions.

¹⁰ The lowered Infl no longer canonically governs the [Spec, VP] position. As pointed out by a reviewer, we further assume, as seems quite natural, that subsequent raising at LF, if it occurs, will not salvage the lack of S-Structure licensing.

¹¹ Note that adult French only licenses and identifies null subjects in the context of subject clitics in Agr, which serve to identify pro.

¹² The data for Daniel and Nathalie were made available to us directly by Patsy Lightbown. The data for Grégoire and Philippe are available through the CHILDES data base (MacWhinney and Snow 1985).

result of verb raising. As we show, both of these expectations are fulfilled. As our model predicts, negative *pas* appears in sentence-initial position solely in the context of non-finite verbs. Some examples are given on the left-hand side in (17).

(17) *French data showing that [\pm finite] determines location of Neg ($p < .001$)*

[–finite]

[+finite]

Nathalie

- | | |
|--|---|
| a. Pas la poupée dormir. (1-9-3)
not the doll sleep | g. Elle a pas la bouche. (1-10-2)
she doesn't have the mouth |
| b. Pas manger la poupée. (1-9-3)
not eat the doll | h. Veux pas lolo. (2-0-1)
want not milk |

Daniel

- | | |
|--|--|
| c. Pas casser. (1-8-1)
not break | i. Marche pas. (1-8-3)
works not |
| d. Pas attraper papillon. (1-8-3)
not catch butterfly | j. Me plaît pas monsieur là. (1-8-3)
to me please not man there |

Philippe

- | | |
|--|---|
| e. Pas chercher les voitures. (2-1-3)
not look for the cars | k. Est pas mort. (2-2-0)
is not dead |
| f. Pas rouler en vélo. (2-2-1)
not roll on bike | l. Ça tourne pas. (2-1-3)
this turns not |

Grégoire

- | | |
|--|--|
| (Grégoire produced no nonfinite negatives) | m. Elle roule pas. (1-11-3)
it doesn't roll |
| | n. Veux pas. (1-10-0)
want not |

However, as V-to-I movement is in evidence in the earliest available transcripts, the negative is often not sentence-initial in early French. Children acquiring French were therefore found to produce relatively few equivalents of the Neg-initial construction found in English. From the beginning, as Weissenborn and Verrips (1989) have also shown, French-speaking children produce negatives in which the verb is tensed and Neg occurs to its right, as seen in the examples on the right-hand side in (17). This suggests that Infl is present and that the tensed verb raises to Infl in the early grammar. What is important here is that the placement of Neg to the left or the right of the verb is strictly a function of the [\pm finite] nature of the verb. This was found to be highly significant for all four children (measured individually at different ages in chi-square tests of contingency between [\pm finite] and \pm initial Neg). Results revealed a highly significant effect of tense on word order for each child ($p < .001$). Less than 3% of all negative utterances

produced by the French-speaking children failed to conform to this Neg-V_{-fin}/V_{+fin}-Neg pattern.¹³

The facts represented in (17) indicate an adult-like underlying grammar. First, they show that verbs do not remain in their D-Structure position in tensed sentences, thereby demonstrating that the child's grammar comprises a distinction between tensed and untensed verbal forms. In parallel with the adult grammar, this distinction is expressed in terms of verb raising. Second, they serve as further proof that the negative resides under IP: negatives in tensed clauses are consistently located to the right of the verb because tensed verbs raise to Infl. If, as suggested by Klima and Bellugi (1966) and others, early sentence-initial negation reflected the position of negative scope, then its postverbal position in early French would clearly not be expected. Also note that children never substitute the anaphoric negative *non* for nonanaphoric *pas*. This shows that utterances like those on the left-hand side of (17) do not simply result from the child's generalizing anaphoric structures to nonanaphoric contexts. Finally, as Weissenborn (1988a,b) has also argued, the French data constitute evidence for functional projections in early child language since Infl must be available as a landing site for the raised verb. Arguing against the view that functional categories mature at roughly 24 months of age, many of the finite negatives observed are produced well before the second birthday.

We assume the S-Structure analysis given in (12) for the nonfinite cases in (17), with subjects possibly generated either to the left or to the right of V'.¹⁴ But the finite cases, which involve verb raising to Infl, are analyzed as in (18).

(18) *Syntactic structure of child utterance (17h)*

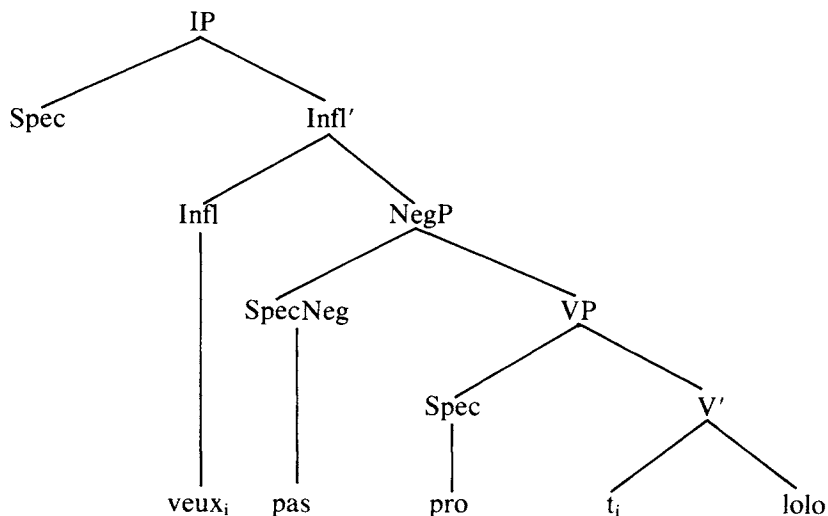

¹³ See Pierce 1989, 1992, for further specific numbers and statistics.

¹⁴ We do not exclude the possibility that some of the nonfinite examples with postverbal subjects have undergone "short" movement of the verb—whether the verb is an infinitive or a past participle—to a functional projection below Infl (Pollock 1989, Déprez 1989b, 1990). In this case, the linear order Neg-V is maintained, and subject may be assumed to be generated strictly to the left of V.

In our model, Infl in child grammar may assign Case to a VP-internal subject. What, then, are the facts with respect to subject placement in French child language? In conformity with our prediction that verb raising in the absence of subject raising should result in postverbal subjects in French child language, there are an impressive number of postverbal subject constructions in the speech of the four children studied (Pierce 1989, 1992). (19) gives the percentages of lexical subjects that occur postverbally during a specified early period.

(19) *Proportion of lexical subjects that occur postverbally (excluding right or left dislocations with overt clitics)*

Nathalie	(1-11-3 to 2-0-1)	85%
Philippe	(2-1-3 to 2-3-0)	74%
Daniel	(1-8-1 to 1-11-3)	65%
Grégoire	(1-9-3 to 2-3-0)	76%

In this instance, then, the prediction of the model is strongly confirmed. Examples of postverbal subjects from the four children are shown in (20).

(20) *Some postverbal subjects in French child language*

[intransitive]		[transitive]	
[+finite]			
a.	Lit maman. (N2-0-1) reads mommy	VOS	g. A bobo fesse Nathalie. (N2-0-1) has a booboos buttocks Nathalie
b.	Pleure clown. (D1-8-3) cries clown	VSO	h. Pousses toi sandales. (D1-8-3) push you sandals
c.	Travaille papa. (P2-2-1) works daddy	VOS	i. Fait du bruit la voiture. (P2-2-1) makes noise the car
d.	Tombe Victor. (G2-0-1) falls Victor	VSO	j. Veut encore Adrien du pain. (G2-1-3) wants more Adrien _{subj} bread
[-finite]			
e.	Assis la poupée. (N2-2-1) sit the doll	VOS	k. Manger salade Adrien. (G1-9-2) eat salad Adrien
f.	Dormir là Michel. (P2-2-1) sleep there Michel	VOS	l. Plus jouer tracteur bébé. (D1-8-1) no more play tractor baby

We take these data to demonstrate that subjects are licensed to remain in VP-internal position. Note, however, that (20) includes instances of both VSO and VOS order in transitive constructions. This suggests that there are potentially two sources for postverbal subjects in French child language, one being verb raising and the other being either underlying VOS order or right dislocation with an empty pronoun. We will not investigate these alternatives further here (though see Pierce 1989, 1992, for discussion).

Suffice it to say that at least some postverbal subjects must be attributed to verb raising, providing additional evidence for the availability of verb raising in early French.

This contrasts tellingly with English development, where postverbal subjects occur very infrequently. We take this to suggest that VP-internal subjects are generated only to the left of V' in English, contrary to the approach taken by Kitagawa (1986).¹⁵ In fact, the vast majority of declarative postverbal subjects occur with unaccusatives and *be*. Some examples with unaccusatives are given in (21) and, with *be*, in (40).

(21) *Unaccusatives with postverbal subjects in English child language*

- a. Going it. (Naomi, 1-10-1)
- b. Going (re)corder. (Naomi, 1-10-1)
- c. Come car. (Eve, 1-6-0)
- d. Came a man. (Eve, 1-8-0)
- e. Fall pants. (Nina, 1-11-2)
- f. Fall down lady. (Nina, 1-11-2)
- g. Come Lois. (Peter, 2-1-3)
- h. Broken the light. (Peter, 2-2-0)

Unaccusatives with postverbal subjects account for 90% of declarative VS order in English child language (Pierce 1992). This is exactly as expected if the young child sometimes fails to raise the D-Structure object to the [Spec,IP] position. At the same time it provides a new type of evidence for the unaccusative nature of these particular verbs.

The absence of postverbal subjects in unergative contexts, along with the unobserved negatives in (15), leads us to conclude that children acquiring English never incorrectly raise main verbs to Infl. French-speaking 2-year-olds, on the other hand, widely employ the V-to-I rule. This is consistent with Emonds's (1978) and Pollock's (1989) characterization of the relevant parameter distinguishing English from French and shows that this parameter is set not long after the onset of syntactic development. Indeed, although we do not explore the nature of the relevant input here, it would appear that the input necessary to set this parameter correctly—evidence of the type in (6) and (7)—is readily available in unambiguous form in the two languages.

Early setting of the V-to-I parameter in French suggests that X⁰-movement is readily available. Another phenomenon in French child language conforming to this analysis is clitic placement. Object clitic constructions are produced quite early in French development (Clark 1985, Weissenborn 1988a). If, as argued by Kayne (1989), clitic placement is an instance of head movement to Infl, the early use of object clitics provides additional evidence for both functional projections and X⁰-movement in early child grammar. The data with respect to subject clitics are even more striking in this regard. There are various

¹⁵ Since underlying VS order is clearly not instantiated in English, it is doubtful that it exists in French, the directionality of θ -assignment being parallel in the two languages. This in turn suggests that the VOS structures of French may be better analyzed as instances of dislocation and the untensed VS structures in (17) as instances of "short" movement in the sense of Pollock (1989).

motivations for analyzing subject pronouns as syntactic clitics in adult spoken French (Kayne 1975, Jaeggli 1982, Déprez 1990). Pierce (1989) extends this analysis to child French. The strongest piece of pertinent evidence is that subject pronouns are found to distribute exclusively with finite verbs in the output of the four children studied. That is, children produced the sentences in (22) but did not produce sentences like those in (23).

(22) *Pronominal subjects*

- | | |
|---|---|
| <p>a. Il est pas là. (N2-2-2)
it is not there</p> <p>b. Et je veux. (N2-2-2)
and I want</p> <p>c. Elle dort. (D1-8-1)
she sleeps</p> <p>d. Il veut un bruit. (D1-11-1)
he wants a noise</p> | <p>e. On marche à l'école. (P2-1-3)
we walk to school</p> <p>f. Elle tombe. (P2-2-0)
she falls</p> <p>g. Il mange. (G1-10-0)
he eats</p> <p>h. Je suis là. (G2-3-0)
I am here</p> |
|---|---|

(23) *Pronominal structures not occurring in child language*

- | | |
|---|--|
| <p>*SubjCl-V_{-fin}</p> <p>a. Il être pas là.</p> <p>b. Elle dormir.</p> <p>c. On marcher à l'école.</p> <p>d. Il manger.</p> | <p>*V-SubjCl</p> <p>e. Et veux je.</p> <p>f. Veut il un bruit./Veut un bruit il.</p> <p>g. Tombe elle.</p> <p>h. Suis je là./Suis là je.</p> |
|---|--|

The true contingency between tense and subject clitics, a striking effect akin to the positioning of the negative contingent upon tense, has many important implications. That there are virtually no cases of pronominal subjects in untensed clauses clearly demonstrates the child's ability to distinguish between tensed and untensed forms. It further suggests that subject clitics are affixes, generated in Infl and lexically realized only when bound to a raised verb. As with the word-order tense contingency in negatives, this effect was determined to be highly significant for all children measured individually ($p < .001$) (Pierce 1989, 1992). Note that the analysis of subject clitics as affixes provides a simple account for their preverbal position, in contrast to the frequent postverbal positioning of full NP subjects. If French subject clitics were analyzed as syntactic pronouns, categorically equivalent to full NPs, one would expect them to parallel the distribution of NPs, as they do in the English acquisition data. That the child's choice of verbal form with respect to finiteness is far from arbitrary is further demonstrated by the finding that the child at a given age uses the same verb in both finite and nonfinite form. Consider the utterance pairs in (24).

(24) *Children's use of both [+finite] and [-finite] forms of individual verbs*

[-finite]	[+finite]
<i>Philippe</i>	
a. Pas rouler en vélo. (2-2-2) not roll on the bike	Elle roule. it rolls
b. Pour rentrer là la voiture. (2-2-2) for reentering there the car	Il rentre. it reenters
<i>Nathalie</i>	
c. Train va tomber. (2-2-2) train is going to fall	Tombe. falls
d. Voir l'auto papa. (2-2-2) to see car papa's	Elle la voit l'auto. she it sees the car
<i>Daniel</i>	
e. Veut dormir bébé. (1-11-1) wants to sleep baby	Dort bébé. sleeps baby
f. Je vais faire café moi. (1-11-1) I'm going to make coffee me	Fait la vaisselle. does the dishes
<i>Grégoire</i>	
g. Mangé le chien. (1-10-0) ate the dog	Il mange. he eats
h. Est passé dans la rue. (1-11-3) passed in the street	Elle passe. it passes

The subject clitic–tense contingency and the finding that children use both finite and nonfinite forms of individual verbs constitute further evidence that very young children have “knowledge of Infl” and indeed have functional categories.

Before extending this discussion to German child language, let us summarize and interpret the comparative English-French results. The comparative data on the acquisition of negation show that Neg is situated under IP in early grammar. The evidence for this comes from the observation that the English-speaking child's negative never surfaces to the left of an auxiliary and that the French-speaking child's negative generally occurs to the right of the raised verb. Although we observed no raising of main verbs in early English, there is firm evidence for V-to-I movement in early French based on contingency between Neg-placement and the finite/nonfinite distinction. Concerning the position of the subject, we have observed evidence in both languages that the child, in contrast to the adult, can maintain subjects in VP-internal position at S-Structure. Moreover, whereas postverbal subjects in English child declaratives are limited to unaccusative contexts, postverbal subjects in child French arguably result from V-to-I movement in conjunction with unraised VP-internal subjects. The absence of obligatory

subject raising, therefore, cannot simply be attributed to the absence of the Infl projection: as demonstrated by the existence of verb movement, the Infl node is indeed projected from the start of grammatical development. In the model we have adopted, VP-internal subjects result from the option for Infl to assign Case under government. On this view, unraised subjects in child language do not provide evidence for the absence of a Case system or the inoperability of the Case Filter. Rather, we suggest that the Case Filter is present in early grammar and that an early option for assignment under government is available for all categories (i.e., V as well as Infl). In the course of development, this option may be suppressed for Infl, in conformity with the adult setting of the parameter in English. Note that this view does not entail the resetting of a parameter. Rather, both options, Case assignment in [Spec,IP] and Case assignment under government, appear to be available to the child until the proper setting is attained.

2.3 *The German Evidence*

In previous sections we have shown how data on word order in English and French acquisition may be construed as support for two recent theoretical developments, namely, the hypothesis that the subject occurs in a VP-internal position at D-Structure and the hypothesis that the relation between Infl and the verb involves X^0 -movement. We have also shown that a verb movement parameter distinguishing French from English appears to be set early. If correct, this demonstrates that the child's D-Structure contains functional projections and that head movement plays a role in early grammar. In this section we turn to German and show that what is known about the acquisition of negation in this language is consistent with the conclusions reached on the basis of the French and English findings.¹⁶

Our predictions for German are as follows. As in English and French, the option not to raise the subject is expected to result in subject NPs surfacing to the right of the negative at some early stage. With respect to verb movement, the picture is slightly more complex than in French. Verb movement in adult German is manifested by the verb-second rule, standardly analyzed as involving the movement of a verbal head to Comp. Following Vikner and Schwartz (1988), among others, we assume that the movement of the verb to Comp in German involves an initial string-vacuous movement to a head-final Infl. There are thus two cases to consider. If V-to-I movement is acquired early in German, as in French, it should be evidenced by the presence of tensed verbs in sentence-final position. If V-to-C movement is acquired early, then the German child grammar should manifest the verb-second phenomenon.

Although the German data reveal more variability in word order than the English and French data, our predictions concerning the position of the subject and the movement of the verb to Infl are verified. The movement of the verb to Comp, on the other hand, appears to be acquired somewhat later. As we will show, the data reveal a timing dis-

¹⁶ Since our analysis of German is based upon descriptions of the data as found in the literature, and often not on firsthand examination of these data, the discussion here should be recognized as speculative.

crepancy in the acquisition of these distinct instances of X^0 -movement. V-to-I movement shows consistency with our French findings and appears to be acquired early. V-to-C movement, which we consider for the first time in this section, appears to be comparatively delayed. We return to a more detailed discussion of V-to-C movement in section 3, where we will show that the delay in the mastery of this rule is not limited to German, but is observed in another verb-second language (namely, Swedish), as well as in French and English. We first look at the data pertaining to the placement of subjects and then turn to the discussion of verb movement.

If, as we maintain, negation is sentence-internal and subjects have the option to remain in VP-internal position in early child sentences, we expect instances of post-Neg subjects in German, just as in English and French. As shown by the examples in (25), this expectation is fulfilled.

(25) *Some early negatives with overt subjects*

- a. Nein ich putt mache. (Simone, 26 months; Miller 1979)
no I break
'I won't break it.'
- b. Nein Auto kaput. (Kathrin, 25–26 months; Park 1981)
no car broken
'The car isn't broken.'
- c. Nein diese Messer auau. (Kathrin, 25–26 months; Park 1981)
no this knife hurting
'This knife is not hurting.'
- d. Nein Batsch Hunger. (Kathrin, 25–26 months; Park 1981)
no uncle hunger
'The uncle is not hungry.'
- e. Nein dick Baby. (Kathrin, 25–26 months; Park 1981)
no fat baby
'The baby will not get fat.'
- f. Nicht da Mama. (Kathrin, 25–26 months; Park 1981)
not here Mommy
'Mommy is not here.'

Park (1981:74) reports that "in utterances consisting of intrinsic [i.e., nonanaphoric] negation *nein* and the sentence subject, the Neg was always placed before the subject." Clearly, then, for some children overt subjects are consistently placed after the negation at the 2-year-old stage. It should be noted, however, that other researchers (i.e., Miller 1979) have not observed such a strong tendency.¹⁷ As shown in (26), subjects can also occur prenegatively at this early period.

¹⁷ Whereas Park (1981) puts a special emphasis on negative utterances, Miller (1979) specifically excludes negative utterances from the scope of his study.

(26) *Prenegative subjects*

- a. Baby nich Nuckel habe. (Simone, 24 months; Miller 1979)
baby not pacifier have
'Baby doesn't (?) have pacifier.'
- b. Mone nich das Eis habe. (Simone, 26 months; Miller 1979)
(Si)mone not the ice has
'Simone doesn't have the ice.'
- c. Ich nein schlafen. (Felix 1987)
I not sleep
'I don't sleep.'

Although we will not explore the child's choice of negative element here, note that both *nein* and *nicht* surface in initial and in medial position. In parallel to the English data discussed above, the Neg-medial occurrences in (26) provide some support for the hypothesis that the German negation is generated in sentence-internal position in child as in adult grammar.¹⁸

If utterances such as those in (25) are not spurious or unsystematic instances of word order error, and they appear not to be, then they require explanation. The framework adopted here readily accounts for them as instances of the failure to raise the subject out of the VP. The occurrence of overt subjects after the negative in early German suggests that assignment of nominative Case under government is available to the child acquiring this language, as in English and French.

The variability in subject placement found in German child language also conforms to our model. Recall our claim that VP-internal positioning of the subject is one option made available to the child by principles of UG. The pre-Neg position of subjects, on the other hand, may be taken to reflect a concurrent option to assign Case under the

¹⁸ The fact that children tend to use the terms *no* in English and *nein* in German in early negative utterances has often been taken to be significant, and to reflect the generalization of anaphoric negative structures to nonanaphoric contexts (Wode 1977). Note first that the notion of structural generalization seems quite difficult to spell out in any meaningful way. An anaphoric negative is in essence a nonstructured utterance that negates a prior proposition. There is thus no structure, apart from linear order, to generalize. Furthermore, if the choice of negative form were significant, we would expect it to have cross-linguistic generality. As mentioned above, however, the anaphoric form *non* is never used in early negative utterances in French. Why, then, this lexical overgeneralization of the anaphoric negator? Plausibly, the relatively idiosyncratic choice of the negative element—children appear to vary with respect to their choice of negative elements and are not necessarily consistent—may be related to phonetic complexity. The word *nicht* in German features a final consonant cluster that combines a palatal fricative and a stop. Studies of phonological acquisition cited by Owens (1984) reveal that "sounds classed by manner of articulation are acquired roughly in the following order: nasals, glides, stops, liquids, fricatives, and finally affricates. Sounds classed by point of articulation are acquired in the order: labials, velars, alveolars, dentals, palatals" (Akmajian et al. 1990:421). According to this classification, the palatal fricative that is part of the final cluster of *nicht* is one of the latest sounds to be acquired. Moreover, a number of studies of phonological development have shown that children usually start out with a CV syllable structure (see Smith 1973, among others). Consequently, they reduce clusters in every position (and especially in final position) and often delete final consonants. Avoidance of more complex phonological forms might provide a plausible alternative explanation for the choice of negative forms by children. Support for such a suggestion could be provided by language acquisition data from a language in which the nonanaphoric negative particle is clearly more phonetically complex than the anaphoric negator.

Spec-head relation, a possibility that is expected if Infl in the child's grammar is an optional raising category, in the sense of Koopman and Sportiche (1988). Alternatively, pre-Neg subjects may result from \bar{A} -movement of the subject out of the VP-internal Case-marked position to an adjoined or \bar{A} -Specifier position, as in adult topicalization.¹⁹

In early German, as in seemingly all 2-year-old language, overt expression of the subject is optional. (27) provides examples of subjectless sentences with initial negation.

(27) *German subjectless sentences with initial (nonanaphoric) negation*

- a. Nein Kata helfen. (Kathrin, 24–26 months; Park 1981)
no Kata help (don't help Kata)
- b. Nein sitzen. (Meike, 22 months; Miller 1979)
no/don't sit
- c. Nein sauber machen. (Lars, 23 months; Wode 1977)
no clean make (don't want to be cleaned)
- d. Nich Hause gehn. (Meike, 22 months; Miller 1979)
no home go
- e. Nich aua mache. (Simone, 23 months; Miller 1979)
don't/doesn't hurt
- f. Nich putt mache. (Simone, 22 months; Miller 1979)
not broken make
- g. Nein auch Hause gehn. (Meike, 22 months; Miller 1979)
no also house go
- h. Nein kanns. (Bo, 26 months; Weissenborn and Verrrips 1989)
no can (do) it
- i. Neine sach. (Lukas, 27 months; Weissenborn and Verrrips 1989)
not said
- j. Net schreibe. (Grimm 1973)
not write
- k. Nein fahren lasse. (Bo, 26 months; Weissenborn and Verrrips 1989)
not drive let-1sg

These data are also expected within the assumed model, since empty subjects are licensed in a VP-internal position by a governing Infl.

The existence of nonanaphoric preverbal negation is well attested throughout the German literature (Wode 1977, Park 1979, 1981, Clahsen 1983, Felix 1987). Clahsen (1983), for one, describes an early stage with negation in initial position 70%–100% of the time. There is also contextual support that these Neg-initial utterances have non-anaphoric interpretation. The example (27g), for instance, was spontaneously produced

¹⁹ Although the variability of subject placement is consistent with our model, it appears to be problematic for a model in which the child's negation is assumed to be generated in a sentence-peripheral position.

by the child Meike as she was playing at the house of another child and was asked by her mother to follow her home. By uttering (27g), Meike clearly expressed her refusal to comply with her mother's request. In sum, the German data corroborate and reinforce our previous finding with respect to the child's option to maintain subjects in their VP-internal position at S-Structure.

We now turn to the discussion of verb movement. Recall the structures expected under the adopted model. If the child raises the verb to *Comp*, negation should surface in postverbal position. If the verb raises to *Infl* but not to *Comp*, negation should occur preverbally and finite verb forms should appear in sentence-final position. The examples given in (27) show that preverbal negation occurs. This demonstrates that the movement of the verb to *Comp* is decidedly not obligatory in the child's early grammar. There are nevertheless a number of cases where the negation surfaces postverbally. Examples of this type are given in (28).

(28) *Postverbal negation*

- a. De-de-des geht nicht. (Ivar, 28 months; Meisel and Müller 1990)
this works not
- b. Ivar darf nich Tee. (Ivar, 29 months; Meisel and Müller 1990)
Ivar can not tea (Ivar cannot have tea)
- c. Geht nicht. (Meike, 21 months; Miller 1979)
works not
- d. Paßt nicht. (Meike, 22 months; Miller 1979)
fits not
- e. Mag nicht. (Simone, 21 months; Miller 1979)
like not
- f. Pass nein. (Kathrin, 24 months; Park 1989)
fit no
- g. Macht nicht aua. (Simone, 23 months; Miller 1979)
make not hurt

The data in (28) suggest that verb raising to *Comp*, although not obligatory, is nonetheless possible. Among acquisition theorists, however, there is a clear consensus regarding a strong preference for verb-final position during an extended period of development (Miller 1979, Mills 1985, Clahsen and Smolka 1986). Miller (1979) calculates that 90% of the three-word utterances spoken by one 22-month-old child (Meike) and 78% of those spoken by another (Simone) are verb-final. As noted by Clahsen and Smolka (1986), the preference for verb-final position reflects the head-final structure of German. At the same time it indicates a delay in the acquisition of the verb-second rule. Early German, then, is clearly more often verb-final than verb-second. At first glance, this finding seems to be at odds with the conclusion, strongly supported by the French data, that verb movement is an early acquisition. But the observed delay concerns the movement of the verb to *Comp*. The final position of the verb here is compatible with our

interpretation of the French data if, as we assume, verb movement in German involves a first step to Infl in sentence-final position.

Many verbs in the early verb-final constructions occur with infinitival morphology. (26c), (27b), and (27c) are a few examples.²⁰ While still in the verb-final-preferred stage, however, German children are said to make basic finite/nonfinite distinctions by using root, third person singular, and infinitival affixes (Mills 1985, Clahsen and Smolka 1986). In Clahsen and Smolka's (1986) second stage in the development of verb placement, explicitly finite verbs often occur in final position. Note that it is important to consider sentences with three or more words in assessing the position of the verb in the child's grammar. This is because the final position of the verb in two-word nonnegative utterances is structurally ambiguous among its D-Structure position, its position once raised to head-final Infl, and its position following verb raising to Comp—provided that the preverbal constituent has itself undergone movement to [Spec,CP]. Consequently, only utterances of three words or more with finite verbs in final position evidence the movement of the verb to an Infl-final position. Examples of the relevant construction are shown in (29).

(29) *Some noninfinitival verbs in final position of three-word utterances*

- a. Das Julia mach. (Mathias, 28 months; Clahsen and Smolka 1986)
this Julia make-root
- b. Nul Pier Julia neid. (Mathias, 33 months; Clahsen and Smolka 1986)
only paper Julia cut-root
- c. Mone auch schläft. (Simone, 22 months; Miller 1979)
Simone also sleeps-3sg
- d. Ander auch geht. (Meike, 22 months; Miller 1979)
other also goes-3sg
- e. Das auch paßt. (Meike, 22 months; Miller 1979)
this also fits-3sg
- f. Mama auch kam. (Meike, 22 months; Miller 1979)
mother also came (past tense)
- g. Da Bela Küche-backe macht. (Kathrin, 26 months; Park 1981)
here Bela cake-baking does-3sg
- h. Decke putt macht. (23 months; Scupin and Scupin, quoted in Mills 1985)
ceiling broken make-3sg
- i. Ivar Buch Buch liest. (Ivar, 28 months; Meisel and Müller 1990)
Ivar book book reads-3sg
- j. Var ein (S)iff macht. (Ivar, 29 months; Meisel and Müller 1990)
Ivar a boat builds-3sg

²⁰ It should be noted that verbs with *-en* morphology sometimes occur in verb-second position.

Table 3
Present tense endings in German

<i>Person</i>	<i>Singular</i>	<i>Plural</i>
1	-e	-en
2	-st	-t (ihr)/-en (Sie)
3	-t	-en

Since utterances of this type are predicted to occur only if early German manifests verb movement to a head-final Infl, they provide strong evidence for our hypothesis.

Taking a closer look at the finite/nonfinite distinction in German child language, there is reason to believe that the extent of finite verb forms used at early stages has been underestimated. The frequent occurrence of the *-en* ending has often been interpreted in the literature as a nonfinite ending (see Clahsen 1983, among others). Since the *-en* ending cuts across tensed and untensed forms of the German verbal morphology, however, this interpretation may be questioned. Note first that the *-en* ending is the most ambiguous ending of the German verbal morphology, since it corresponds to all plural present tense forms, as well as to the imperative.²¹ Table 3 depicts the correspondence between verbal morphological endings and person/number in the present tense.

Consider next table 4, which summarizes the verbal endings used with overt third person singular subjects by one child, Kathrin, between 24 and 26 months of age (Park 1981:20). Although it is quite clear from this table that the child has not acquired proper agreement paradigms (i.e., only the *-t* ending is correct for third person singular), the *-en* ending does not appear to dominate at early stages in this child's verbal productions. The same observation is made by Mills (1985) on the basis of two children between the ages of 16 and 22 months. Mills also notes that when the Agent was overtly present in the sentence, the *-t* ending clearly dominated, even in structures where the verb occurred in sentence-final position.

Table 5 displays the distribution of tensed forms produced by another child as a function of verb-second frequency. Note that this child uses the *-t* ending 100% correctly at a stage when the rate of verb-second utterances is quite low (30%). This suggests that the child distinguishes finite and nonfinite verbal forms well before the V-to-C pattern is fully acquired.

Finally, one of the children studied by Miller (1979), Simone, produced the overwhelming majority of her verbs with the *-e* ending. This ending is also subject to various interpretations. Although it is morphologically equivalent to the adult's first person sin-

²¹ See Mills 1985 for speculations that the frequent use of verb-final imperatives by parents may reinforce the use of the *-en* form by children.

Table 4
Kathrin's third person singular verb forms

<i>Phase</i>	<i>I</i>	<i>II</i>	<i>III</i>
<i>Age</i>	24:0–24:1	25:3–26:0	26:1–26:3
Base form	6	19 (20%)	16 (17%)
-e ending	6	11 (11%)	4 (4%)
-t ending	2	26 (27%)	48 (51%)
-en ending	1	41 (42%)	27 (28%)

gular present tense ending, the evidence suggests that this is not the only interpretation given to it by the child. As shown in (30), she is also using it with third person subjects.

(30) *-e ending with third person singular subjects*

- a. Maxe auch male. (Simone, 22 months)
Maxe also draws
- b. Maxe auch Mauer hoppe mache.
Maxe also the wall jump makes
'Maxe also jumps over the wall.'

Contextual information further suggests that the child is not always using the *-e* ending strictly as a phonetic variant for the infinitival form. She indeed seemed to be able to distinguish the infinitival ending *-en* from the *-e* ending or the base form. Consider, for instance, the dialogue in (31).

Table 5
Verb placement and percentage of correctly used verb inflections (Mathias; Clahsen and Smolka 1986)

	<i>Stage I</i>	<i>Stage II</i>	35.6	36.3	37.3	39.3
V2	32%	30%	54%	64%	97%	97%
Base	45%	60%	66%	82%	95%	94%
-n	48%	77%	80%	80%	87%	100%
-t	80%	100%	100%	95%	86%	100%
-e	(100%)	(80%)	60%	67%		100%
-st	X	X	X	(.50)	100%	100%

- (31) Simone: Hände waschen.
 hands wash(inf)
 (Simone takes a chair and drags it through the kitchen to the hand-washing sink)
- Mother: “Hände waschen” sagt sie. Ne?
 hands wash(inf) says she hey
- Simone: Hände wasche. (with falling stress on last syllable)
 (Impatiently)
- Mother: So, dann wasch du mal deine Hände.
 OK then wash your hands now
- Simone: Hände wasche.
 (Impatiently, Simone climbs on the chair to be able to reach the hand-washing sink)

Despite the mother’s repetition of the child’s *-en* ending, Simone corrects her own utterance by replacing the *-en* ending with *-e* (Miller 1979:333). Other contexts in which such a differentiation appears to be made are shown in the dialogues in (32) and (33).

- (32) Context: Simone and Meike are playing together. An adult gives Meike a handkerchief, which Meike uses as a pacifier.
- Simone: Taschentuch . . . Nase putzen.
 handkerchief nose wipe(+en)
- Adult: Nase putzen, ja.
 nose wipe(+en) yes
- Simone: Meike putz. (lacht)
 Meike wipe (laughs)
- (33) Context: Simone sees her mother standing near the window.
- Simone: Fenster gucken.
 (Springs up)
 Fenster gucki.
 Fenster . . . gucki.
 window look(+en, +i, +i)
- Mother: Komm mal, Mone! Fenster gucken, ne?
 come on Simone window look(+en) hey

In (32) we again see an adult using the infinitival form in repeating a child’s utterance, at the same time that the child avoids using that form with a third person subject. In (33) the child corrects her own ending before adult repetition. If, as suggested by these examples, the child can discriminate between the *-e* ending and the infinitival ending, then the existence of tensed verb-final structures in early child language is strongly

supported. As Miller's data reveal, 100% of Simone's utterances of three words or more with verb-final order are produced with the *-e* ending.

In sum, it appears that verbs with finite morphology can occur in sentence-final position in the grammar of early German. This finding is compatible with the hypothesis that V-to-I movement in German involves string-vacuous movement of the verb to a head-final Infl position. Observe that we have a basis upon which to argue that contrary to first impression, the prevalence of verbs in final position in early German and the related delay in mastery of the verb-second rule (as reported in Clahsen and Smolka 1986 and elsewhere) are not at odds with the French findings regarding the earliness of verb movement. We suggest that knowledge of tense distinctions is reflected in German exactly as it is in French, namely, by the movement of the verb to Infl. At the same time, this intermediate movement of the verb to Infl in sentence-final position serves as evidence for a two-stage movement of the verb to Comp in adult German.

To summarize thus far, the known facts of German acquisition support both the hypothesis that the subject is generated within VP and the observation that V-to-I movement is acquired early in those languages in which it plays a role. The head-final nature of the Infl projection in German allows us to reconcile the clear French evidence for verb movement with the apparently more mixed data found in German.

3 Verb Movement to Comp

The combination of frequent verb-final positioning and frequent Neg-initial positioning points to a delay in the development of V-to-C movement in early German. That is, V-to-C movement does not appear to be acquired at the same time as V-to-I movement. As it turns out, cross-linguistic evidence from other verb-second languages manifests a comparable delay in V-to-C movement. Furthermore, non-verb-second languages such as French and English appear to manifest a similar delay in V-to-C movement in interrogative contexts. We first consider acquisition data in another verb-second language, Swedish, before turning to French and English interrogative structures.

3.1 A Glance at Swedish

A brief look at Swedish provides independent confirmation of the delay in the acquisition of the verb-second rule. Swedish is an SVO language. Therefore, V-to-C movement is instantiated in (XP) V S order, as well as in the ordering of the verb with respect to negation and sentential adverbs. Table 6, reproduced from Platzack 1990, shows that V-to-C movement is at best inconsistently applied in the early stages of Swedish acquisition. These facts parallel the German facts noted above. Table 6 shows that Swedish-speaking children have a high number of finite forms well before the verb-second constraint is fully acquired. This suggests that the distinction between finite and nonfinite forms is acquired earlier than the verb-second rule, as in German.

Table 6

Swedish: Percentage of finite forms (FIN) prior to stable acquisition of verb-second movement (V/2) (Platzack 1990)

Age in months	<i>Embla</i>		<i>Freja</i>		<i>Tor</i>	
	FIN	V/2 stable	FIN	V/2 stable	FIN	V/2 stable
22	53%	no				
24	56%	no				
26	85%	no	61%	no	39%	no
28	90%	yes	68%	no	78%	no
30	99%	yes	45%	no	79%	no
32			83%	no	93%	yes
34			95%	yes		

Also relevant here is the distribution of the verb with respect to the subject. Table 7 summarizes the possible positions of overt subjects in early Swedish, prior to the acquisition of the full verb-second rule. Note that when the verb is in infinitive form, postverbal subject structures are limited to ergative verbs, mirroring our findings for English. In both languages, when the verb does not move, subjects can be postverbal only with ergative verbs. These constructions suggest that subjects can remain in VP-internal position in early Swedish, as in early English.²² As shown in the bottom half of table 7, nonergative VS structures do arise in Swedish, but only with tensed verbs. The fact that nonergative VS structures are restricted to tensed verbs, never occurring with infinitives, strongly suggests that Swedish-speaking children distinguish between finite and nonfinite forms prior to mastering the verb-second rule. They never incorrectly move an infinitive verb.²³ In short, Swedish, like German, manifests a delayed or stepwise acquisition of verb raising to Comp. Both the German and Swedish data indicate that knowledge of the difference between finite and nonfinite clauses is in place well before V-to-C movement stabilizes. We now return briefly to French and English acquisition data to assess the status of V-to-C movement in non-verb-second languages.

²² Platzack does not discuss the ordering of subjects with respect to negation. He provides one example of initial negation with an overt subject in a footnote, *Inte Mamma hjälpa Embla* 'Not Mommy help Embla'. As indicated by the gloss, *inte* is the nonanaphoric negator in Swedish. This structure is expected if early Swedish, like the other languages considered in this article, has the option of not raising subjects. Further data are of course needed to establish the frequency of this construction.

²³ In contrast to the approach taken here, Platzack assumes that the child has no knowledge of the [\pm finite] distinction and that verbal endings are unanalyzed forms in early Swedish. As he himself notes, this assumption leaves unexplained the limitation of verb movement to finite forms.

Table 7

Sentence structures with overt subjects (Platzack 1990)

	NONFINITE SENTENCES					
	<i>Embla</i>		<i>Freja</i>			<i>Tor</i>
	Age	20/22	23/25	20/22	23/24	25/27
S V (XP)	20	36	1	19	16	27
XP S V (YP)	0	4	0	0	1	1
S Adv V (XP)	0	4	0	1	0	0
(XP) V(ergative) S	0	6	0	7	1	3
(XP) V(nonerg) S	0	0	0	0	0	0
Q+inversion	0	0	0	0	0	0
	FINITE SENTENCES					
	<i>Embla</i>		<i>Freja</i>			<i>Tor</i>
	Age	20/22	23/25	20/22	23/24	25/27
S V (XP)	6	58	4	27	46	13
XP S V (YP)	0	2	0	0	1	0
S Adv V (XP)	0	1	0	0	0	0
(XP) V(ergative) S	0	2	0	4	4	1
(XP) V S	4	20	1	5	1	0
Q+inversion	1	15	2	5	2	6

3.2 Verb Movement to Comp in the Acquisition of French and English

In adult French, V-to-C movement is instantiated only in interrogative subject clitic inversion. Not surprisingly, children do not include this construction among their early questions, as (34) illustrates.

(34) *No clitic inversion*

- a. Où il est? (Philippe, 26 months)
where he is
- b. Où ils sont? (Philippe, 26 months)
where they are

- c. Comment on fait pour casser les maisons? (Philippe, 26 months)
how one does to break houses
- d. Où elle est? (Grégoire, 24 months)
where she is

These observations are only suggestive of the absence of V-to-C raising in early French, since subject clitic inversion is admittedly rare in the spoken version of the adult language. A fact that provides a somewhat stronger indication of the lack of V-to-C movement is illustrated in (35). Inversion of the clitic *ce* is obligatory in adult French, even in informal registers. It is therefore noteworthy that young speakers sometimes produce ungrammatical utterances of the type in (35).

(35) *Failure to invert with ce*

- a. Que c'est ça dedans? (Philippe, 26 months)
what this is this in
- b. Et ça que c'est? (Philippe, 26 months)
and that what this is
- c. Que c'est ça fait du bruit? (Philippe, 27 months)
what this is that makes noise
- d. Maintenant qu'on fait? On construit une maison? (Philippe, 27 months)
now what we do we build a house

Such errors plausibly result from the lack of V-to-C movement.

Turning to English, many studies have established that subject-Aux inversion in questions is an early acquisition. This general finding was recently replicated in an extensive study by Stromswold (1990). Stromswold reports that 93% of young children's *wh*-questions are correctly inverted, as are 94% of their yes/no questions. Some early examples of inverted *wh*-questions from the three children studied are provided in (36).

(36) *Subject-Aux inversion in main clause interrogatives*

- a. Where are you? (Eve, 22 months)
- b. What is Fraser doing? (Eve, 22 months)
- c. What did I make? (Nina, 25 months)
- d. What is Daddy holding? (Nina, 27 months)
- e. Can I (have) one? (Peter, 26 months)
- f. What is that? (Peter, 26 months)

Given the standard analysis of Aux inversion as an instance of V-to-C movement, this finding might at first appear to contradict the delay in V-to-C movement observed in the acquisition of other languages. But the contradiction is only apparent. Within the model we have adopted, Aux-subject order in English is ambiguous between two underlying structures. It reflects either the movement of Aux to Comp over a raised subject

in [Spec,IP], as in (37a), or the occurrence of Aux in Infl with the subject in VP-internal position, as in (37b).

- (37) a. [_{CP} Aux [_{IP} S . . .]]
 b. [_{IP} Aux [_{VP} S . . .]]

A number of considerations provide support for the second alternative. According to Stromswold, children never erroneously invert main verbs in questions, with the noteworthy exception of the unaccusative or modal *go*. Recall that, as mentioned above, the absence of postverbal negation in child English shows that V-to-I movement does not occur. Inverted interrogatives with unaccusative verbs are thus better analyzed as involving VP-internal subjects with unmoved verbs. Children furthermore sometimes overgeneralize Aux-subject order to a number of contexts in which the adult grammar does not permit it. First, young children are reported to produce subject-Aux inversion in 14% of their *how come* questions. Some examples from children 2 to 4 years of age are shown in (38).

(38) *Inversion in how come questions (Stromswold 1990)*

- a. How come is that?
 b. Why how come is that?
 c. How comes he (. . .) 'cause he threw it and and . . .
 d. How comes he taking a big bite?

The tendency toward inversion in *how come* questions persists in experimental contexts. Stromswold reports that young children judge incorrectly inverted *how come* questions to be grammatical 50% of the time.

Second, and perhaps more interestingly, children also overgeneralize inverted structures to embedded contexts. As calculated by Stromswold (1990), inversion occurs in children's embedded questions about 10% of the time.²⁴ A few examples from children aged 2 to 4 are shown in (39).

(39) *Inversion in embedded interrogatives (Stromswold 1990)*

- a. I don't know who is dat.
 b. I don't know what is his name.
 c. I don't know what do you think it was.
 d. I don't know what is that bunny called.
 e. I don't know what ingredient do you use to make gumdrops.
 f. I don't know what's that.

In an experimental study, Stromswold also found that children between 2 and 4 years of age judge embedded sentences with inverted auxiliary to be grammatical about 50% of the time.

²⁴ The calculated percentage includes only questions that were undoubtedly inverted (see Stromswold 1990 for a discussion of her criteria). In particular, it excludes questions containing a contracted auxiliary.

Finally, children also appear to overgeneralize inversion to declarative contexts. (40) contains a few examples of Aux-subject word order in noninterrogatives.

(40) *Aux-subject order in declarative contexts (Pierce 1989, 1992)*

- a. Father: Naomi, do you want an egg?
 Child: **No, is it broke.**
 Father: What? The ice is broken? What is broken Naomi?
 Child: **Is it fixed.**
 Father: Is it fixed?
 Child: Is fixed, is broken.
 Father: The ice isn't broken Naomi.
- b. Mother: Look at the shoes.
 Child: **Is shoes off.** Shoes shoes shoes.
 Mother: What about it? Yes, those are shoes.
- c. Mother: Hey, Naomi, what's this?
 Child: **Is it, flowers.**
- d. Adult: It's Goldilocks. Is it?
 Child: **Yep, is it, Goldilocks.**
- e. Situation: *(Peter sees adult look at the tape recorder)*
 Child: **Is that tape, right Patsy?**
- f. Adult: But what I like best were the monkeys.
 Child: . . . **Was monkeys climb on that balloon.**
- g. Child: **Do you drink it.**
 Comment: *(seems to be a statement)*
- h. Child: **Here are they.**

Errors such as those in (38) to (40) are expected if the subject generated in VP-internal position can fail to raise, at the same time that I-to-C movement has not been mastered so that the Aux occurs in Infl. In light of the German evidence, the probable analysis of early Aux-subject order in both questions and declaratives is that the auxiliary elements have not raised to Comp. On this view, the errors in (38) through (40) provide additional support for the VP-internal hypothesis, and the high frequency of inversion in interrogatives is compatible with a delay in V-to-C movement.

Yet another observation argues for hypothesis (37b). As graphed by Stromswold (1990), the development of inversion in interrogatives conforms to a U-shaped curve. This is illustrated in figure 1.

Observe that an initial period of relatively consistent Aux-subject order is followed by a drop in inversion during the 3- to 4-year-old period. At around 3 years, the percentage of inversion in *wh*-questions drops substantially. It appears that children pass through a phase of confusion in which the rate of correct inversion descends before climbing again to stability. This drop in the inversion rate, although noted by Stromswold as well

Inversion for Matrix Argument and Adjunct *Wh*-Questions

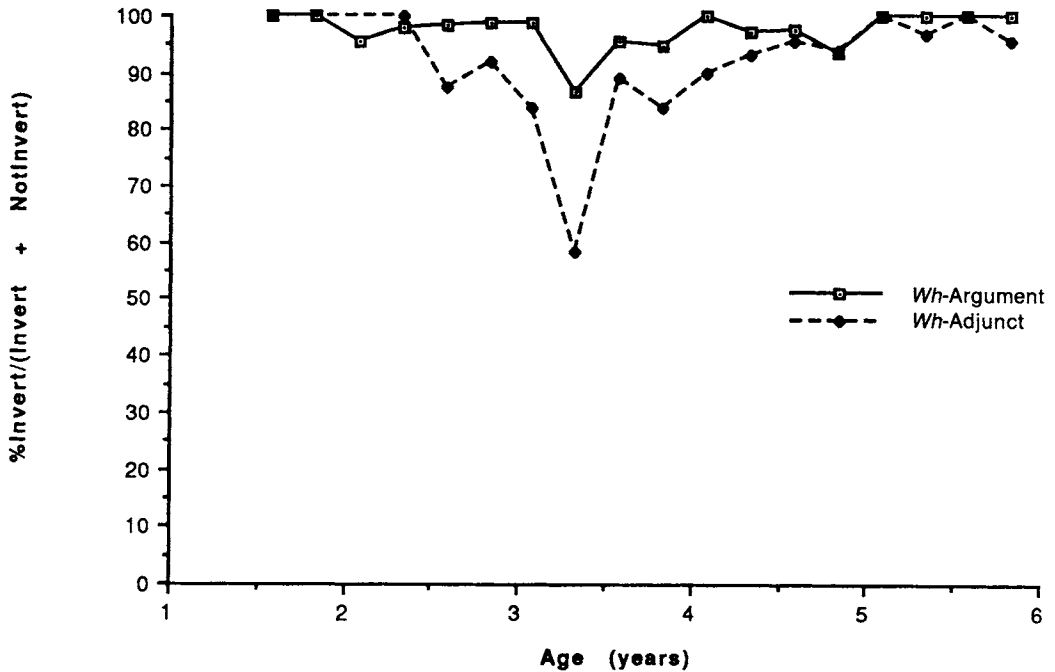

Figure 1

Developmental trend: argument and adjunct *wh*-questions. (From Stromswold 1990:fig. 5.55. Used by permission of the author.)

as by Labov and Labov (1978), has yet to be explained. If, as we suggest, early success in inversion reflects nonraising of the subject, the drop in inversion may be accounted for if the onset of obligatory subject raising is prior to the onset of obligatory V-to-C movement in interrogatives.²⁵ Observe, furthermore, that the age at which the drop in inversion ends in English (about 3½ years) corresponds by and large to the age at which the verb-second pattern stabilizes in German and Swedish. If not coincidental, this correspondence in timing provides strong cross-linguistic support for our hypothesis. Our hypothesis thereby accounts for a cluster of observations that have so far eluded explanation.

²⁵ Note that under the proposed interpretation, the age at which the drop of inversion begins suggests that the VP-internal option remains available until about 3 years. Findings reported in section 2.1 on Neg-initial utterances suggest, on the other hand, that the VP-internal option may end earlier. It is possible that this timing discrepancy results from the differing properties of null versus lexically filled Infl. As suggested above, null Infl ceases to assign Case under government at an early stage. This Case-assigning property, however, may persist longer for lexically filled Infs.

Summarizing this section, there is cross-linguistic evidence for a delay in the acquisition of the V-to-C rule. Verb movement to Comp is possible in the child's grammar, but its obligatory character in verb-second languages and in interrogative structures is not in evidence during the early stage we have examined. The question arises, then, why the child's grammar fails to manifest consistency with respect to V-to-C movement. It has been suggested in the literature that this lack of stability indicates a failure to distinguish finite from nonfinite forms (Platzack 1990). This hypothesis, however, is not consistent with the cross-linguistic findings we have reviewed. There is little doubt that this distinction is present at an early stage in French, and there are strong indications that it is also present in other child languages.

It has been suggested elsewhere that the delay in V-to-C movement acquisition stems from the lack of functional projections in the child's grammar (Guilfoyle and Noonan 1988, Radford 1990, among others). As we have mentioned, very early use of V-to-I movement suggests that Infl is present from the start. The possibility of V-to-C movement implies that the lag in consistency does not result from the overall absence of the Comp projection. If Comp were simply absent, we would expect V-to-C movement to be impossible, since there would be no appropriate landing site for the verbal head. Note, moreover, that the view that the Comp projection is not present in the immature grammar leaves the well-known early acquisition of *wh*-movement unexplained.²⁶

What, then, might explain the lag in the mastery of V-to-C movement? We suggest that this delay results from the distinctive character of verb movement to Comp. In contrast with V-to-I movement, V-to-C movement arguably involves substitution rather than adjunction (Rizzi and Roberts 1989) and is, in any event, never directly motivated by morphological considerations. If V-to-C movement does not occur, no affix, whether abstract or phonologically realized, remains stranded. Recent syntactic work further distinguishes V-to-I movement and V-to-C movement with respect to the principles that motivate them. Pollock (1989) proposes that the relation between the verb and Infl is motivated by quantification theory. He suggests that Infl (really Tense) is an operator that, like other operators, must bind a variable. Overt movement of the verb to Infl is one way to satisfy this requirement. Since it appeals to general principles of quantification, this proposal establishes a relation between V-to-I movement and *wh*-movement. Both are obligatory (at S-Structure or at LF), and this obligatory character stems from the general ban on vacuous quantification (Chomsky 1981). Early acquisition of *wh*-movement suggests independently that the ban on vacuous quantification is at work in early child grammar. On this view, it comes as no surprise that V-to-I movement is, as we have shown, also acquired early. These considerations, however, do not apply to the movement of the verb to Comp. Whatever the ultimate motivation for V-to-C movement, it arguably involves neither morphological unification nor the ban on vacuous

²⁶ If, as proposed by Chomsky (1986), *wh*-movement is to the [Spec,CP], in the absence of this landing site we would expect children to produce *wh*-in-situ questions for a time—something that, to the best of our knowledge, they do not do.

quantification, both commonly assumed to be inviolable principles of UG. Assuming that the lack of verb movement to Comp violates no other deep UG principles, we expect V-to-C movement to be optional until sufficient or relevant evidence allows the correct fixation of the appropriate parameter. In contrast to previous proposals, this hypothesis suggests an account for the optional status of V-to-C movement in early grammar that is consistent with verb movement being functional in the early grammar.

4 Conclusion

In this article we have used data from child language to evaluate theoretical claims in linguistics. We presented acquisition data from a number of languages showing that subjects surface internal to the VP in early grammar. We suggested that the parametric option to assign nominative Case under government is what licenses these structures in the child's language. Once this option is excluded, subjects in a VP-internal position are ruled out. We are not claiming, however, that the early grammar is a direct reflection of D-Structure, or of a lack of transformations. Verb movement is operational in those languages in which it plays a role. Furthermore, the errors described here as the result of failure to raise the subject out of the verb phrase are attributed to a valid grammatical option to assign nominative Case to that position—and not to the unavailability of the Case Filter or of NP-movement in general. Evidence for a stage during which the subject may remain VP-internal supports the view that the surface position of the subject in the adult language is derived via movement. In this way, the acquisition data argue for a model of grammar that includes NP-movement over a model in which the relation between a subject and its θ -marking verb requires a mechanism of indexing (Williams, to appear). In short, the placement of subjects in early child language argues for the existence of a subject position that is closer to the predicate than the position seen in adult grammar.

Regarding the acquisition of inflectional affixation and the status of functional projections, we have shown that the distinction between English and French in terms of verb raising is supported. Postverbal subjects in French and the differing placement of Neg in the two languages were two types of evidence discussed. On this basis, we argued against the view that the Infl is dispensable in the analysis of early child grammars. The lack of parallelism between Infl acquisition and Comp acquisition, wherein young children display more inconsistency in movement to Comp than in movement to Infl, presents a further challenge to acquisition models that assume that the class of functional projections matures at about 2 years of age. Contrary to our findings, such models predict parallel growth in functional structure (Radford 1990). Yet it is hard to imagine a mechanism other than maturation that could enforce the appearance of functional structure at a given stage of development. Given the abstract interpretation of functional elements, it is unlikely, say, that a semantic bootstrapping procedure could account for their acquisition. And if, as many have claimed (Borer 1983, Chomsky 1991), it is indeed the acquisition of lexical properties of functional elements that drives the parameter-setting

process, then the question arises how syntactic development could proceed at all in the absence of functional categories; if functional categories cannot be represented at the early stages, then a parameter-setting process that is driven by functional elements cannot proceed until some later point. Yet the evidence we have discussed here demonstrates that the verb movement parameter distinguishing English from French is set extremely early, apparently before 2 years of age.

Finally, with respect to the development of negative structures, the cross-linguistic child language data, when viewed as a whole, indicate that negation is situated under IP. The initial stage in the development of negation described by Klima and Bellugi (1966) appears to be substantiated, and is readily explained by the underlying position of the subject.

Another general theme we have touched on in this article is optionality. Our research suggests that optionality of movement pervades the early grammar. We find optionality in subject raising and in verb movement. Under established conceptions of grammar building, according to which the child must first hypothesize grammars that generate small languages in order to avoid a violation of the Subset Principle (Berwick 1985), these results may come as somewhat of a surprise. Indeed, they challenge the outlook that syntax acquisition is constrained by the Subset Principle. They suggest instead, as expected in a selectional model of acquisition such as the parameter-setting model, that earlier stages may be stages in which the grammar has yet to “stabilize” on unique settings of various parameters.

References

- Adams, Marianne. 1987. From Old French to the theory of pro-drop. *Natural Language and Linguistic Theory* 5:1–32.
- Akmajian, Adrian, Richard Demers, Ann Farmer, and Robert Harnish. 1990. *Linguistics*. 3rd ed. Cambridge, Mass.: MIT Press.
- Aldridge, Michelle. 1988. The acquisition of Infl. Doctoral dissertation, University College of North Wales, Bangor.
- Bellugi, Ursula. 1967. The acquisition of negation. Doctoral dissertation, Harvard University, Cambridge, Mass.
- Berwick, Robert. 1985. *The acquisition of syntactic knowledge*. Cambridge, Mass.: MIT Press.
- Besten, Hans den. 1977. On the interaction of root transformations and lexical deletive rules. Ms., University of Amsterdam.
- Bloom, Lois. 1970. *Language development: Form and function in emerging grammars*. Cambridge, Mass.: MIT Press.
- Bloom, Paul. 1988. Subject position and child language. Ms., MIT, Cambridge, Mass.
- Bloom, Paul. 1990. Subjectless sentences in child language. *Linguistic Inquiry* 21:491–504.
- Bonet, Eulàlia. 1990. Subjects in Catalan. In *MIT working papers in linguistics* 13, 1–26. Department of Linguistics and Philosophy, MIT, Cambridge, Mass.
- Borer, Hagit. 1983. *Parametric syntax*. Dordrecht: Foris.
- Borer, Hagit. 1989. Anaphoric AGR. In Jaeggli and Safir 1989.
- Brown, Roger. 1973. *A first language: The early stages*. Cambridge, Mass.: Harvard University Press.

- Brown, Roger, and Ursula Bellugi. 1964. Three processes in the child's acquisition of syntax. *Harvard Educational Review* 34:133–151.
- Chomsky, Noam. 1981. *Lectures on government and binding*. Dordrecht: Foris.
- Chomsky, Noam. 1986. *Barriers*. Cambridge, Mass.: MIT Press.
- Chomsky, Noam. 1991. Some notes on economy of derivation and representation. In *Principles and parameters in comparative grammar*, ed. Robert Freidin, 417–454. Cambridge, Mass.: MIT Press.
- Clahsen, Harald. 1983. Some remarks on the acquisition of German negation. *Journal of Child Language* 10:465–469.
- Clahsen, Harald, and Smolka. 1986. Psycholinguistic evidence and the description of V-second phenomena in German. In *V-2 phenomena in Germanic languages*, ed. Hubert Haider and M. Prinzhorn, 137–166. Dordrecht: Foris.
- Clark, Eve. 1985. The acquisition of Romance with special reference to French. In Slobin 1985.
- Contreras, Heles. 1987. Small clauses in English and Spanish. *Natural Language and Linguistic Theory* 5:225–243.
- Déprez, Viviane. 1989a. On the typology of syntactic positions and the nature of chains. Doctoral dissertation, MIT, Cambridge, Mass.
- Déprez, Viviane. 1989b. Stylistic inversion and verb movement. In *Proceedings of the Eastern States Conference on Linguistics* 88. Ohio State University, Columbus.
- Déprez, Viviane. 1990. On two ways of moving the verb in French. In *MIT working papers in linguistics* 12, 47–85. Department of Linguistics and Philosophy, MIT, Cambridge, Mass.
- Emonds, Joseph. 1978. The verbal complex V'-V in French. *Linguistic Inquiry* 9:151–175.
- Felix, Sasha. 1987. *Cognition and language growth*. Dordrecht: Foris.
- Fukui, Naoki, and Margaret Speas. 1986. Specifiers and projections. In *MIT working papers in linguistics* 6. Department of Linguistics and Philosophy, MIT, Cambridge, Mass.
- Guilfoyle, Eithne. 1986. The acquisition of tense and the emergence of lexical subjects in child grammars of English. In *McGill working papers in linguistics*. McGill University, Montreal, Quebec.
- Guilfoyle, Eithne, and Máire Noonan. 1988. Functional categories and language acquisition. Paper presented at the Thirteenth Annual Boston University Conference on Language Development.
- Huang, C.-T. James. 1989. Pro-drop in Chinese: A generalized control theory. In Jaeggli and Safir 1989, 185–214.
- Hyams, Nina. 1986. *Language acquisition and the theory of parameters*. Dordrecht: Reidel.
- Hyams, Nina, and Osvaldo Jaeggli. 1988. Null subjects and morphological development in child language. Ms., UCLA, Los Angeles, Calif., and University of Southern California, Los Angeles.
- Jaeggli, Osvaldo. 1982. *Topics in Romance syntax*. Dordrecht: Foris.
- Jaeggli, Osvaldo, and Ken Safir, eds. 1989. *The null subject parameter*. Dordrecht: Kluwer.
- Kayne, Richard. 1975. *French syntax: The transformational cycle*. Cambridge, Mass.: MIT Press.
- Kayne, Richard. 1989. Null subjects and clitic climbing. In Jaeggli and Safir 1989, 239–261.
- Kazman, Richard. 1988. Null arguments and the acquisition of Case and Infl. Paper presented at the Thirteenth Annual Boston University Conference on Language Development.
- Kazman, Richard. 1990. The genesis of functional categories. Paper presented at the Fifteenth Annual Boston University Conference on Language Development.
- Kitagawa, Yoshihisa. 1986. Subjects in Japanese and English. Doctoral dissertation, University of Massachusetts, Amherst.
- Klima, Edward, and Ursula Bellugi. 1966. Syntactic regularities in the speech of children. In *Psycholinguistic papers*, ed. J. Lyons and R. Wales, 183–208. Edinburgh: Edinburgh University Press.

- Koopman, Hilda, and Dominique Sportiche. 1988. Subjects. Ms., UCLA, Los Angeles, Calif.
- Kuroda, S.-Y. 1988. Whether we agree or not: A comparative syntax of English and Japanese. *Linguisticae Investigationes* 12:1–47.
- Labov, William, and Teresa Labov. 1978. Learning the syntax of questions. In *Recent advances in the psychology of language: Formal and experimental approaches*, ed. R. Campbell and P. Smith. New York: Plenum.
- Laka, Itziar. 1989. Constraints on sentence negation. In *MIT working papers in linguistics* 10, 199–216. Department of Linguistics and Philosophy, MIT, Cambridge, Mass.
- Lebeaux, David. 1988. Language acquisition and the form of the grammar. Doctoral dissertation, University of Massachusetts, Amherst.
- Lightbown, Patsy. 1977. Consistency and variation in the acquisition of French. Doctoral dissertation, Columbia University, New York.
- MacWhinney, B., and C. Snow. 1985. The child language data exchange system. *Journal of Child Language* 12:271–296.
- Meisel, Jürgen, and Natasha Müller. 1990. On the position of finiteness in early child grammar. Evidence from simultaneous acquisition of two first languages: French and German. Paper presented at the Fifteenth Annual Boston University Conference on Language Development.
- Miller, M. 1979. *The logic of language development in early childhood*. Berlin: Springer-Verlag.
- Mills, Ann. 1985. The acquisition of German. In Slobin 1985, 141–263.
- Owens, R. E. 1984. *Language development: An introduction*. Columbus, Ohio: Charles E. Merrill Publishing Co.
- Park, T. 1979. Some facts on negation: Wode's four-stage developmental theory of negation revisited. *Journal of Child Language* 6:147–151.
- Park, T. 1981. *The development of syntax in the child with special reference to German*. Innsbruck.
- Pierce, Amy. 1989. On the emergence of syntax: A crosslinguistic study. Doctoral dissertation, MIT, Cambridge, Mass.
- Pierce, Amy. 1992. *Language acquisition and syntactic theory: A comparative analysis of French and English child grammars*. Dordrecht: Kluwer.
- Platzack, Christer. 1990. A grammar without functional categories: A syntactic study of early Swedish child language. In *Working papers in Scandinavian syntax* 45. Linguistics Department, University of Trondheim.
- Pollock, Jean-Yves. 1989. Verb movement, Universal Grammar, and the structure of IP. *Linguistic Inquiry* 20:365–424.
- Radford, Andrew. 1990. *Syntactic theory and the acquisition of English syntax*. Oxford: Basil Blackwell.
- Rizzi, Luigi. 1986. Null objects in Italian and the theory of *pro*. *Linguistic Inquiry* 17:501–557.
- Rizzi, Luigi, and Ian Roberts. 1989. French complex inversion. Ms., University of Geneva.
- Roeper, Thomas, and Edwin Williams, eds. 1987. *Parameter setting*. Dordrecht: Reidel.
- Slobin, Daniel, ed. 1985. *The crosslinguistic study of language acquisition*. Vol. 1. Hillsdale, N.J.: Lawrence Erlbaum Assoc.
- Smith, N. 1973. *The acquisition of phonology*. Cambridge: Cambridge University Press.
- Sportiche, Dominique. 1988. A theory of floating quantifiers and its corollaries for constituent structure. *Linguistic Inquiry* 19:425–449.
- Stromswold, Karin. 1990. Learnability and the acquisition of auxiliaries. Doctoral dissertation, MIT, Cambridge, Mass.
- Suppes, Patrick, R. Smith, and Madeleine Léveillé. 1973. The French syntax of a child's noun phrases. *Archives de Psychologie* 42:207–269.
- Vikner, Sten. 1990. Verb movement and the licensing of NP-positions in the Germanic languages. Doctoral dissertation, University of Geneva.

- Vikner, Sten, and Bonnie Schwartz. 1988. All verb second clauses are CPs. In *Working papers in Scandinavian syntax* 43, 27–50. Linguistics Department, University of Trondheim.
- Weissenborn, Jürgen. 1988a. The acquisition of clitic object pronouns and word order in French: Syntax or morphology? Ms., Max Planck Institut für Psycholinguistik, Nijmegen.
- Weissenborn, Jürgen. 1988b. Null subjects in early grammars: Implications for parameter-setting theories. Paper presented at the Thirteenth Annual Boston University Conference on Language Development.
- Weissenborn, Jürgen, and Monica Verrips. 1989. Negation as a window to the structure of early child language. Ms., Max Planck Institut für Psycholinguistik, Nijmegen.
- Williams, Edwin. To appear. *Thematic structure in syntax*. Cambridge, Mass.: MIT Press.
- Wode, H. 1977. Four early stages in the development of L1 negation. *Journal of Child Language* 4:87–102.
- Zanuttini, Raffaella. 1989. Two types of negative markers. In *Proceedings of NELS 20*. GLSA, University of Massachusetts, Amherst.

(Déprez)

Department of Linguistics
Rutgers University
18 Seminary Place
New Brunswick, New Jersey 08903
vdeprez@clarity.princeton.edu

(Pierce)

77 Randall Road
Princeton, New Jersey 08540
pierce@clarity.princeton.edu