

Weierstraß-Institut für Angewandte Analysis und Stochastik

im Forschungsverbund Berlin e.V.

Preprint

ISSN 0946 – 8633

Homogeneous nucleation for Glauber and Kawasaki dynamics in large volumes at low temperatures

A. Bovier¹, F. den Hollander², C. Spitoni²

submitted: June 10, 2008

¹ Weierstraß-Institut
für Angewandte Analysis
und Stochastik
Mohrenstr. 39
10117 Berlin
and
Technische Universität Berlin
Institut für Mathematik
Str. des 17. Juni 136
10623 Berlin
Germany
E-Mail: bovier@wias-berlin.de

² Mathematical Institute
Leiden University
P.O. Box 9512
2300 RA Leiden
and
EURANDOM
P.O. Box 513
5600 MB Eindhoven
The Netherlands
E-Mail: denholla@math.leidenuniv.nl
E-Mail: spitoni@eurandom.tue.nl

No. 1331
Berlin 2008



2000 *Mathematics Subject Classification.* 60K35, 82C26.

Key words and phrases. Glauber dynamics, Kawasaki dynamics, critical droplet, metastable transition time, last-exit biased distribution, Dirichlet principle, Berman-Konsowa principle, capacity, flow, cluster expansion .

Research supported in part by the DFG and NWO in the Dutch-German Bilateral Research Group “Mathematics of Random Spatial Models from Physics and Biology”, and by NWO grant 613.000.556.

Edited by
Weierstraß-Institut für Angewandte Analysis und Stochastik (WIAS)
Mohrenstraße 39
10117 Berlin
Germany

Fax: + 49 30 2044975
E-Mail: preprint@wias-berlin.de
World Wide Web: <http://www.wias-berlin.de/>

ABSTRACT. In this paper we study metastability in large volumes at low temperatures. We consider both Ising spins subject to Glauber spin-flip dynamics and lattice gas particles subject to Kawasaki hopping dynamics. Let β denote the inverse temperature and let $\Lambda_\beta \subset \mathbb{Z}^2$ be a square box with periodic boundary conditions such that $\lim_{\beta \rightarrow \infty} |\Lambda_\beta| = \infty$. We run the dynamics on Λ_β starting from a random initial configuration where all the droplets (= clusters of plus-spins, respectively, clusters of particles) are small. For large β , and for interaction parameters that correspond to the metastable regime, we investigate how the transition from the metastable state (with only small droplets) to the stable state (with one or more large droplets) takes place under the dynamics. This transition is triggered by the appearance of a single *critical droplet* somewhere in Λ_β . Using potential-theoretic methods, we compute the *average nucleation time* (= the first time a critical droplet appears and starts growing) up to a multiplicative factor that tends to one as $\beta \rightarrow \infty$. It turns out that this time grows as $Ke^{\Gamma\beta}/|\Lambda_\beta|$ for Glauber dynamics and $K\beta e^{\Gamma\beta}/|\Lambda_\beta|$ for Kawasaki dynamics, where Γ is the local canonical, respectively, grand-canonical energy to create a critical droplet and K is a constant reflecting the geometry of the critical droplet, provided these times tend to infinity (which puts a growth restriction on $|\Lambda_\beta|$). The fact that the average nucleation time is inversely proportional to $|\Lambda_\beta|$ is referred to as *homogeneous nucleation*, because it says that the critical droplet for the transition appears essentially independently in small boxes that partition Λ_β .

1. INTRODUCTION AND MAIN RESULTS

1.1. Background. In a recent series of papers, Gaudillière, den Hollander, Nardi, Olivieri, and Scoppola [12, 13, 14] study a system of lattice gas particles subject to Kawasaki hopping dynamics in a *large* box at low temperature and low density. Using the so-called *path-wise approach* to metastability (see Olivieri and Vares [23]), they show that the transition time between the metastable state (= the gas phase with only small droplets) and the stable state (= the liquid phase with one or more large droplets) is inversely proportional to the volume of the large box, provided the latter does not grow too fast with the inverse temperature. This type of behavior is called *homogeneous nucleation*, because it corresponds to the situation where the critical droplet triggering the nucleation appears essentially independently in small boxes that partition the large box. The *nucleation time* (= the first time a critical droplet appears and starts growing) is computed up to a multiplicative error that is small on the scale of the *exponential* of the inverse temperature. The techniques developed in [12, 13, 14] center around the idea of *approximating* the low temperature and low density Kawasaki lattice gas by an *ideal gas* without interaction and showing that this ideal gas stays *close to equilibrium* while exchanging particles with droplets that are growing and shrinking. In this way, the large system is shown to behave essentially like the union of many small independent systems, leading to homogeneous nucleation. The proofs are long and complicated, but they provide considerable detail about the *typical trajectory* of the system prior to and shortly after the onset of nucleation.

In the present paper we consider the same problem, both for Ising spins subject to Glauber spin-flip dynamics and for lattice gas particles subject to Kawasaki hopping dynamics. Using the *potential-theoretic approach* to metastability (see Bovier [5]), we improve *part* of the results in [12, 13, 14], namely, we compute the *average* nucleation time up to a multiplicative error that *tends to one* as the temperature tends to zero, thereby providing a very sharp estimate of the time at which the gas starts to condensate.

We have no results about the typical time it takes for the system to grow a large droplet after the onset of nucleation. This is a hard problem that will be addressed in future work. All that we can prove is that the dynamics has a negligible probability to shrink down a supercritical droplet once it has managed to create one. At least this shows that the appearance of a single critical droplet indeed represents the threshold for nucleation, as was shown in [12, 13, 14]. A further restriction is that we need to draw the initial configuration according to a *class* of initial distributions on the set of subcritical configurations, called the

last-exit biased distributions, since these are particularly suitable for the use of potential theory. It remains a challenge to investigate to what extent this restriction can be relaxed. This problem is addressed with some success in [12, 13, 14], and will also be tackled in future work.

Our results are an extension to large volumes of the results for small volumes obtained in Bovier and Manzo [8], respectively, Bovier, den Hollander, and Nardi [7]. In large volumes, even at low temperatures *entropy* is competing with energy, because the metastable state and the states that evolve from it under the dynamics have a highly non-trivial structure. Our main goal in the present paper is to extend the potential-theoretic approach to metastability in order to be able to deal with large volumes. This is part of a broader programme where the objective is to adapt the potential-theoretic approach to situations where entropy cannot be neglected. In the same direction, Bianchi, Bovier, and Ioffe [3] study the dynamics of the random field Curie-Weiss model on a finite box at a fixed *positive* temperature.

As we will see, the basic difficulty in estimating the nucleation time is to obtain sharp upper and lower bounds on *capacities*. Upper bounds follow from the Dirichlet variational principle, which represents a capacity as an infimum over a class of test functions. In [3] a new technique is developed, based on a variational principle due to Berman and Konsowa [2], which represent a capacity as a supremum over a class of unit flows. This technique allows for getting lower bounds and it will be exploited here too.

1.2. Ising spins subject to Glauber dynamics. We will study models in finite boxes, Λ_β , in the limit as both the inverse temperature, β , and the volume of the box, $|\Lambda_\beta|$, tend to infinity. Specifically, we let $\Lambda_\beta \subset \mathbb{Z}^2$ be a square box with odd side length, centered at the origin with periodic boundary conditions. A spin configuration is denoted by $\sigma = \{\sigma(x) : x \in \Lambda_\beta\}$, with $\sigma(x)$ representing the spin at site x , and is an element of $\mathcal{X}_\beta = \{-1, +1\}^{\Lambda_\beta}$. It will frequently be convenient to identify a configuration σ with its *support*, defined as $\text{supp}[\sigma] = \{x \in \Lambda_\beta : \sigma(x) = +1\}$.

The interaction is defined by the the usual Ising Hamiltonian

$$H_\beta(\sigma) = -\frac{J}{2} \sum_{\substack{(x,y) \in \Lambda_\beta \\ x \sim y}} \sigma(x)\sigma(y) - \frac{h}{2} \sum_{x \in \Lambda_\beta} \sigma(x), \quad \sigma \in \mathcal{X}_\beta, \quad (1.1)$$

where $J > 0$ is the pair potential, $h > 0$ is the magnetic field, and $x \sim y$ means that x and y are nearest neighbors. The *Gibbs measure* associated with H_β is

$$\mu_\beta(\sigma) = \frac{1}{Z_\beta} e^{-\beta H_\beta(\sigma)}, \quad \sigma \in \mathcal{X}_\beta, \quad (1.2)$$

where Z_β is the normalizing partition function.

The dynamics of the model will be a continuous-time Markov chain, $(\sigma(t))_{t \geq 0}$, with state space \mathcal{X}_β whose transition rates are given by

$$c_\beta(\sigma, \sigma') = \begin{cases} e^{-\beta[H_\beta(\sigma') - H_\beta(\sigma)]_+}, & \text{for } \sigma' = \sigma^x \text{ for some } x \in \Lambda_\beta, \\ 0, & \text{otherwise,} \end{cases} \quad (1.3)$$

where σ^x is the configuration obtained from σ by flipping the spin at site x . We refer to this Markov process as *Glauber dynamics*. It is ergodic and reversible with respect to its unique invariant measure, μ_β , i.e.,

$$\mu_\beta(\sigma) c_\beta(\sigma, \sigma') = \mu_\beta(\sigma') c_\beta(\sigma', \sigma), \quad \forall \sigma, \sigma' \in \mathcal{X}_\beta. \quad (1.4)$$

Glauber dynamics exhibits metastable behavior in the regime

$$0 < h < 2J, \quad \beta \rightarrow \infty. \quad (1.5)$$

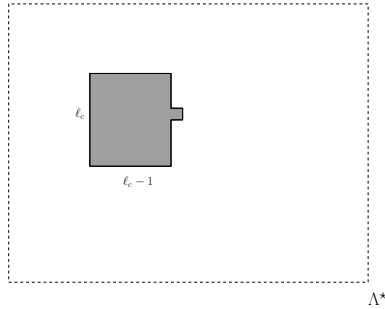

FIGURE 1. A critical droplet for Glauber dynamics on Λ . The shaded area represents the $(+1)$ -spins, the non-shaded area the (-1) -spins (see (1.6)).

To understand this, let us briefly recall what happens in a finite β -independent box $\Lambda \subset \mathbb{Z}^2$. Let \boxplus_Λ and \boxminus_Λ denote the configurations where all spins in Λ are -1 , respectively, $+1$. As was shown by Neves and Schonmann [22], for Glauber dynamics *restricted* to Λ with periodic boundary conditions and subject to (1.5), the *critical droplets* for the crossover from \boxplus_Λ to \boxminus_Λ are the set of all those configurations where the $(+1)$ -spins form an $\ell_c \times (\ell_c - 1)$ quasi-square (in either of both orientations) with a protuberance attached to one of its longest sides, where

$$\ell_c = \left\lceil \frac{2J}{h} \right\rceil \quad (1.6)$$

(see Figs. 1 and 2; for non-degeneracy reasons it is assumed that $2J/h \notin \mathbb{N}$). The quasi-squares without the protuberance are called *proto-critical droplets*.

Let us now return to our setting with finite β -dependent volumes $\Lambda_\beta \subset \mathbb{Z}^2$. We will start our dynamics on Λ_β from initial configurations in which all droplets are “sufficiently small”. To make this notion precise, let $C_B(\sigma)$, $\sigma \in \mathcal{X}_\beta$, be the configuration that is obtained from σ by a “bootstrap percolation map”, i.e., by circumscribing all the droplets in σ with rectangles, and continuing to doing so in an iterative manner until a union of disjoint rectangles is obtained (see Kotecký and Olivieri [19]). We call $C_B(\sigma)$ *subcritical* if all its rectangles fit inside a proto-critical droplet and are at distance ≥ 2 from each other (i.e., are non-interacting).

- Definition 1.1.** (a) $\mathcal{S} = \{\sigma \in \mathcal{X}_\beta: C_B(\sigma) \text{ is subcritical}\}$.
(b) $\mathcal{P} = \{\sigma \in \mathcal{S}: c_\beta(\sigma, \sigma') > 0 \text{ for some } \sigma' \in \mathcal{S}^c\}$.
(c) $\mathcal{C} = \{\sigma' \in \mathcal{S}^c: c_\beta(\sigma, \sigma') > 0 \text{ for some } \sigma \in \mathcal{S}\}$.

We refer to \mathcal{S} , \mathcal{P} and \mathcal{C} as the set of *subcritical*, *proto-critical*, respectively, *critical* configurations. Note that, for ever $\sigma \in \mathcal{X}_\beta$, each step in the bootstrap percolation map $\sigma \rightarrow C_B(\sigma)$ decreases the energy, and therefore the Glauber dynamics moves from σ to $C_B(\sigma)$ in a time of order one. This is why $C_B(\sigma)$ rather than σ appears in the definition of \mathcal{S} .

For $\ell_1, \ell_2 \in \mathbb{N}$, let $R_{\ell_1, \ell_2}(x) \subset \Lambda_\beta$ be the $\ell_1 \times \ell_2$ rectangle whose lower-left corner is x . We always take $\ell_1 \leq \ell_2$ and allow for both orientations of the rectangle. For $L = 1, \dots, 2\ell_c - 3$, let $Q_L(x)$ denote the L -th element in the *canonical* sequence of growing squares and quasi-squares

$$R_{1,2}(x), R_{2,2}(x), R_{2,3}(x), R_{3,3}(x), \dots, R_{\ell_c-1, \ell_c-1}(x), R_{\ell_c-1, \ell_c}(x). \quad (1.7)$$

In what follows we will choose to start the dynamics in a way that is suitable for the use of potential theory, as follows. First, we take the initial law to be concentrated on sets $S_L \subset \mathcal{S}$ defined by

$$S_L = \{\sigma \in \mathcal{S}: \text{each rectangle in } C_B(\sigma) \text{ fits inside } Q_L(x) \text{ for some } x \in \Lambda_\beta\}, \quad (1.8)$$

where L is any integer satisfying

$$L^* \leq L \leq 2\ell_c - 3 \quad \text{with} \quad L^* = \min \left\{ 1 \leq L \leq 2\ell_c - 3 : \lim_{\beta \rightarrow \infty} \frac{\mu_\beta(\mathcal{S}_L)}{\mu_\beta(\mathcal{S})} = 1 \right\}. \quad (1.9)$$

In words, \mathcal{S}_L is the subset of those subcritical configurations whose droplets fit inside a square or quasi-square labeled L , with L chosen large enough so that \mathcal{S}_L is typical within \mathcal{S} under the Gibbs measure μ_β as $\beta \rightarrow \infty$ (our results will not depend on the choice of L subject to these restrictions). Second, we take the initial law to be biased according to the last exit of \mathcal{S}_L for the transition from \mathcal{S}_L to a target set in \mathcal{S}^c . (Different choices will be made for the target set, and the precise definition of the biased law will be given in Section 2.2.) This is a *highly specific* choice, but clearly one of physical interest.

Remarks: (1) Note that $\mathcal{S}_{2\ell_c-3} = \mathcal{S}$, which implies that the range of L -values in (1.9) is non-empty. The value of L^* depends on how fast Λ_β grows with β . In Appendix C.1 we will show that, for every $1 \leq L \leq 2\ell_c - 4$, $\lim_{\beta \rightarrow \infty} \mu_\beta(\mathcal{S}_L)/\mu_\beta(\mathcal{S}) = 1$ if and only if $\lim_{\beta \rightarrow \infty} |\Lambda_\beta| e^{-\beta\Gamma_{L+1}} = 0$ with Γ_{L+1} the energy needed to create a droplet $Q_{L+1}(0)$ at the origin. Thus, if $|\Lambda_\beta| = e^{\theta\beta}$, then $L^* = L^*(\theta) = (2\ell_c - 3) \wedge \min\{L \in \mathbb{N} : \Gamma_{L+1} > \theta\}$, which increases stepwise from 1 to $2\ell_c - 3$ as θ increases from 0 to Γ defined in (1.10).

(2) If we draw the initial configuration σ_0 from some subset of \mathcal{S} that has a strong recurrence property under the dynamics, then the choice of initial distribution on this subset should not matter. This issue will be addressed in future work.

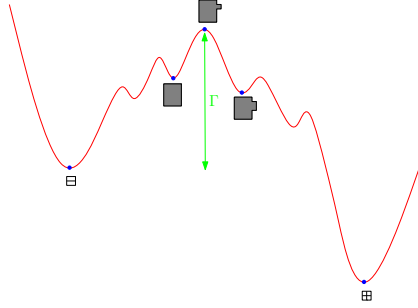

FIGURE 2. A nucleation path from Ξ_{Λ} to Ξ_{Λ} for Glauber dynamics. Γ in (1.10) is the minimal energy barrier the path has to overcome under the local variant of the Hamiltonian in (1.1).

To state our main theorem for Glauber dynamics, we need some further notation. The key quantity for the nucleation process is

$$\Gamma = J[4\ell_c] - h[\ell_c(\ell_c - 1) + 1], \quad (1.10)$$

which is the energy needed to create a critical droplet of (+1)-spins at a given location in a sea of (-1)-spins (see Figs. 1 and 2). For $\sigma \in \mathcal{X}_\beta$, let \mathbb{P}_σ denote the law of the dynamics starting from σ and, for ν a probability distribution on \mathcal{X} , put

$$\mathbb{P}_\nu(\cdot) = \sum_{\sigma \in \mathcal{X}_\beta} \mathbb{P}_\sigma(\cdot) \nu(\sigma). \quad (1.11)$$

For a non-empty set $\mathcal{A} \subset \mathcal{X}_\beta$, let

$$\tau_{\mathcal{A}} = \inf\{t > 0 : \sigma_t \in \mathcal{A}, \sigma_{t-} \notin \mathcal{A}\} \quad (1.12)$$

denote the first time the dynamics enters \mathcal{A} . For non-empty and disjoint sets $\mathcal{A}, \mathcal{B} \subset \mathcal{X}_\beta$, let $\nu_{\mathcal{A}}^{\mathcal{B}}$ denote the *last-exit biased distribution on \mathcal{A} for the crossover to \mathcal{B}* defined in (2.9) in Section 2.2. Put

$$N_1 = 4\ell_c, \quad N_2 = \frac{4}{3}(2\ell_c - 1). \quad (1.13)$$

For $M \in \mathbb{N}$ with $M \geq \ell_c$, define

$$\mathcal{D}_M = \{\sigma \in \mathcal{X}_\beta: \exists x \in \Lambda_\beta \text{ such that } \text{supp}[C_B(\sigma)] \supset R_{M,M}(x)\}, \quad (1.14)$$

i.e., the set of configurations containing a supercritical droplet of size M . For our results below to be valid we need to assume that

$$\lim_{\beta \rightarrow \infty} |\Lambda_\beta| = \infty, \quad \lim_{\beta \rightarrow \infty} |\Lambda_\beta| e^{-\beta\Gamma} = 0. \quad (1.15)$$

Theorem 1.2. *In the regime (1.5), subject to (1.9) and (1.15), the following hold:*

(a)

$$\lim_{\beta \rightarrow \infty} |\Lambda_\beta| e^{-\beta\Gamma} \mathbb{E}_{\nu_{\mathcal{S}_L}^{\mathcal{S}^c}} (\tau_{\mathcal{S}^c}) = \frac{1}{N_1}. \quad (1.16)$$

(b)

$$\lim_{\beta \rightarrow \infty} |\Lambda_\beta| e^{-\beta\Gamma} \mathbb{E}_{\nu_{\mathcal{S}_L}^{\mathcal{S}^c \setminus \mathcal{C}}} (\tau_{\mathcal{S}^c \setminus \mathcal{C}}) = \frac{1}{N_2}. \quad (1.17)$$

(c)

$$\lim_{\beta \rightarrow \infty} |\Lambda_\beta| e^{-\beta\Gamma} \mathbb{E}_{\nu_{\mathcal{S}_L}^{\mathcal{D}_M}} (\tau_{\mathcal{D}_M}) = \frac{1}{N_2}, \quad \forall \ell_c \leq M \leq 2\ell_c - 1. \quad (1.18)$$

The proof of Theorem 1.2 will be given in Section 3. Part (a) says that the average time to create a critical droplet is $[1 + o(1)]e^{\beta\Gamma}/N_1|\Lambda_\beta|$. Parts (b) and (c) say that the average time to go beyond this critical droplet and to grow a droplet that is twice as large is $[1 + o(1)]e^{\beta\Gamma}/N_2|\Lambda_\beta|$. The factor N_1 counts the number of *shapes* of the critical droplet, while $|\Lambda_\beta|$ counts the number of *locations*. The average times to create a critical, respectively, a supercritical droplet differ by a factor $N_2/N_1 < 1$. This is because once the dynamics is “on top of the hill” \mathcal{C} it has a positive probability to “fall back” to \mathcal{S} . On average the dynamics makes $N_1/N_2 > 1$ attempts to reach the top \mathcal{C} before it finally “falls over” to $\mathcal{S}^c \setminus \mathcal{C}$. After that, it rapidly grows a large droplet (see Fig. 2).

Remarks: (1) The second condition in (1.15) will not actually be used in the proof of Theorem 1.2(a). If this condition fails, then there is a positive probability to see a proto-critical droplet in Λ_β under the starting measure $\nu_{\mathcal{S}_L}^{\mathcal{S}^c}$, and nucleation sets in immediately. Theorem 1.2(a) continues to be true, but it no longer describes metastable behavior.

(2) In Appendix D we will show that the *average* probability under the Gibbs measure μ_β of destroying a supercritical droplet and returning to a configuration in \mathcal{S}_L is exponentially small in β . Hence, the crossover from \mathcal{S}_L to $\mathcal{S}^c \setminus \mathcal{C}$ represents the true threshold for nucleation, and Theorem 1.2(b) represents the true nucleation time.

(3) We expect Theorem 1.2(c) to hold for values of M that grow with β as $M = e^{o(\beta)}$. As we will see in Section 3.3, the necessary capacity estimates carry over, but the necessary equilibrium potential estimates are not yet available. This problem will be addressed in future work.

(4) Theorem 1.2 should be compared with the results in Bovier and Manzo [8] for the case of a finite β -independent box Λ (large enough to accommodate a critical droplet). In that case, if the dynamics starts from Ξ_Λ , then the average time it needs to hit \mathcal{C}_Λ (= the set of configurations in Λ with a critical droplet), respectively, Ξ_Λ equals

$$K e^{\beta\Gamma} [1 + o(1)], \quad \text{with } K = K(\Lambda, \ell_c) = \frac{1}{N} \frac{1}{|\Lambda|} \text{ for } N = N_1, N_2. \quad (1.19)$$

(4) Note that in Theorem 1.2 we compute the first time when a critical droplet appears anywhere (!) in the box Λ_β . It is a different issue to compute the first time when the plus-phase appears near the origin. This time, which depends on how a supercritical droplet grows and eventually invades the origin, was studied by Dehghanpour and Schonmann [10, 11], Shlosman and Schonmann [24] and, more recently, by Cerf and Manzo [9].

1.3. Lattice gas subject to Kawasaki dynamics. We next consider the lattice gas subject to Kawasaki dynamics and state a similar result for homogeneous nucleation. Some aspects are similar as for Glauber dynamics, but there are notable differences.

A lattice gas configuration is denoted by $\sigma = \{\sigma(x) : x \in \Lambda_\beta\}$, with $\sigma(x)$ representing the number of particles at site x , and is an element of $\mathcal{X}_\beta = \{0, 1\}^{\Lambda_\beta}$. The Hamiltonian is given by

$$H_\beta(\sigma) = -U \sum_{\substack{(x,y) \in \Lambda_\beta \\ x \sim y}} \sigma(x)\sigma(y), \quad \sigma \in \mathcal{X}_\beta, \quad (1.20)$$

where $-U < 0$ is the binding energy and $x \sim y$ means that x and y are neighboring sites. Thus, we are working in the *canonical ensemble*, i.e., there is no term analogous to the second term in (1.1). The number of particles in Λ_β is

$$n_\beta = \lceil \rho_\beta |\Lambda_\beta| \rceil, \quad (1.21)$$

where ρ_β is the particle density, which is chosen to be

$$\rho_\beta = e^{-\beta\Delta}, \quad \Delta > 0. \quad (1.22)$$

Put

$$\mathcal{X}_\beta^{(n_\beta)} = \{\sigma \in \mathcal{X}_\beta : |\text{supp}[\sigma]| = n_\beta\}, \quad (1.23)$$

where $\text{supp}[\sigma] = \{x \in \Lambda_\beta : \sigma(x) = 1\}$.

Remark: If we were to work in the *grand-canonical ensemble*, then we would have to consider the Hamiltonian

$$H^{gc}(\sigma) = -U \sum_{\substack{(x,y) \in \Lambda_\beta \\ x \sim y}} \sigma(x)\sigma(y) + \Delta \sum_{x \in \Lambda_\beta} \sigma(x), \quad \sigma \in \mathcal{X}_\beta, \quad (1.24)$$

with $\Delta > 0$ an activity parameter taking over the role of h in (1.1). The second term would mimic the presence of an infinite gas reservoir with density ρ_β outside Λ_β . Such a Hamiltonian was used in earlier work on Kawasaki dynamics, when a finite β -independent box with *open boundaries* was considered (see e.g. den Hollander, Olivieri, and Scoppola [18], den Hollander, Nardi, Olivieri, and Scoppola [17], and Bovier, den Hollander, and Nardi [7]).

The dynamics of the model will be the continuous-time Markov chain, $(\sigma_t)_{t \geq 0}$, with state space $\mathcal{X}_\beta^{(n_\beta)}$ whose transition rates are

$$c_\beta(\sigma, \sigma') = \begin{cases} e^{-\beta[H_\beta(\sigma') - H_\beta(\sigma)]_+}, & \text{for } \sigma' = \sigma^{x,y} \text{ for some } x, y \in \Lambda_\beta \text{ with } x \sim y, \\ 0, & \text{otherwise,} \end{cases} \quad (1.25)$$

where $\sigma^{x,y}$ is the configuration obtained from σ by interchanging the values at sites x and y . We refer to this Markov process as *Kawasaki dynamics*. It is ergodic and reversible with respect to the *canonical* Gibbs measure

$$\mu_\beta(\sigma) = \frac{1}{Z_\beta^{(n_\beta)}} e^{-\beta H_\beta(\sigma)}, \quad \sigma \in \mathcal{X}_\beta^{(n_\beta)}, \quad (1.26)$$

where $Z_\beta^{(n_\beta)}$ is the normalizing partition function. Note that the dynamics preserves particles, i.e., it is *conservative*.

Kawasaki dynamics exhibits metastable behavior in the regime

$$U < \Delta < 2U, \quad \beta \rightarrow \infty. \quad (1.27)$$

This is again inferred from the behavior of the model in a finite β -independent box $\Lambda \subset \mathbb{Z}^2$. Let \square_Λ and \blacksquare_Λ denote the configurations where all the sites in Λ are vacant, respectively, occupied. For Kawasaki dynamics on Λ with an *open boundary*, where particles are annihilated at rate 1 and created at rate $e^{-\Delta\beta}$, it was shown in den Hollander, Olivieri, and Scoppola [18] and in Bovier, den Hollander, and Nardi [7] that, subject to (1.27) and for

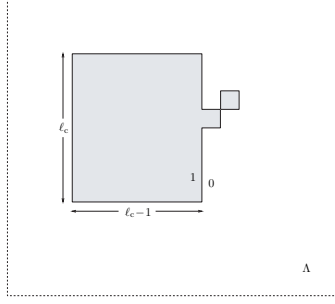

FIGURE 3. A critical droplet for Kawasaki dynamics on Λ (= a proto-critical droplet plus a free particle). The shaded area represents the particles, the non-shaded area the vacancies (see (1.28)). Note that the shape of the proto-critical droplet for Kawasaki dynamics is the same as that of the critical droplet for Glauber dynamics. The proto-critical droplet for Kawasaki dynamics becomes critical when a free particle is added.

the Hamiltonian in (1.24), the critical droplets for the crossover from \square_Λ to \blacksquare_Λ are the set of all those configurations where the particles form

- (1) either an $(\ell_c - 2) \times (\ell_c - 2)$ square with four bars attached to the four sides with total length $3\ell_c - 3$,
- (2) or an $(\ell_c - 1) \times (\ell_c - 3)$ rectangle with four bars attached to the four sides with total length $3\ell_c - 2$,

plus a *free particle* anywhere in the box, where

$$\ell_c = \left\lceil \frac{U}{2U - \Delta} \right\rceil \quad (1.28)$$

(see Figs. 3 and 4; for non-degeneracy reasons it is assumed that $U/(2U - \Delta) \notin \mathbb{N}$).

Let us now return to our setting with finite β -dependent volumes. We define a reference distance, L_β , as

$$L_\beta^2 = e^{(\Delta - \delta_\beta)\beta} = \frac{1}{\rho_\beta} e^{-\delta_\beta\beta} \quad (1.29)$$

with

$$\lim_{\beta \rightarrow \infty} \delta_\beta = 0, \quad \lim_{\beta \rightarrow \infty} \beta\delta_\beta = \infty, \quad (1.30)$$

i.e., L_β is marginally below the typical interparticle distance. We assume L_β to be odd, and write $B_{L_\beta, L_\beta}(x)$, $x \in \Lambda_\beta$, for the square box with side length L_β whose center is x .

- Definition 1.3.** (a) $\mathcal{S} = \{\sigma \in \mathcal{X}_\beta^{(n_\beta)} : |\text{supp}[\sigma] \cap B_{L_\beta, L_\beta}(x)| \leq \ell_c(\ell_c - 1) + 1 \forall x \in \Lambda_\beta\}$.
(b) $\mathcal{P} = \{\sigma \in \mathcal{S} : c_\beta(\sigma, \sigma') > 0 \text{ for some } \sigma' \in \mathcal{S}^c\}$.
(c) $\mathcal{C} = \{\sigma' \in \mathcal{S}^c : c_\beta(\sigma, \sigma') > 0 \text{ for some } \sigma \in \mathcal{S}\}$.
(d) $\mathcal{C}^- = \{\sigma \in \mathcal{C} : \exists x \in \Lambda_\beta \text{ such that } B_{L_\beta, L_\beta}(x) \text{ contains a proto-critical droplet plus a free particle at distance } L_\beta\}$.
(e) $\mathcal{C}^+ =$ the set of configurations obtained from \mathcal{C}^- by moving the free particle to a site at distance 2 from the proto-critical droplet.

As before, we refer to \mathcal{S} , \mathcal{P} and \mathcal{C} as the set of *subcritical*, *proto-critical*, respectively, *critical* configurations. Note that, for every $\sigma \in \mathcal{S}$, the number of particles in a box of size L_β does not exceed the number of particles in a proto-critical droplet. These particles do not have to form a cluster or to be near to each other, because the Kawasaki dynamics brings them together in a time of order $L_\beta^2 = o(1/\rho_\beta)$.

The initial law will again be concentrated on sets $\mathcal{S}_L \subset \mathcal{S}$, this time defined by

$$\mathcal{S}_L = \{\sigma \in \mathcal{X}_\beta^{(n_\beta)} : |\text{supp}[\sigma] \cap B_{L_\beta, L_\beta}(x)| \leq L \ \forall x \in \Lambda_\beta\}, \quad (1.31)$$

and L any integer satisfying

$$L^* \leq L \leq \ell_c(\ell_c - 1) + 1 \quad \text{with} \quad L^* = \min \left\{ 1 \leq L \leq \ell_c(\ell_c - 1) + 1 : \lim_{\beta \rightarrow \infty} \frac{\mu_\beta(\mathcal{S}_L)}{\mu_\beta(\mathcal{S})} = 1 \right\}. \quad (1.32)$$

In words, \mathcal{S}_L is the subset of those subcritical configurations for which no box of size L_β carries more than L particles, with L again chosen such that \mathcal{S}_L is typical within \mathcal{S} under the Gibbs measure μ_β as $\beta \rightarrow \infty$.

Remark: Note that $\mathcal{S}_{\ell_c(\ell_c-1)+1} = \mathcal{S}$. As for Glauber, the value of L^* depends on how fast Λ_β grows with β . In Appendix C.2 we will show that, for every $1 \leq L \leq \ell_c(\ell_c - 1)$, $\lim_{\beta \rightarrow \infty} \mu_\beta(\mathcal{S}_L)/\mu_\beta(\mathcal{S}) = 1$ if and only if $\lim_{\beta \rightarrow \infty} |\Lambda_\beta| e^{-\beta(\Gamma_{L+1} - \Delta)} = 0$ with Γ_{L+1} the energy needed to create a droplet of $L + 1$ particles, closest in shape to a square or quasi-square, in $B_{L_\beta, L_\beta}(0)$ under the grand-canonical Hamiltonian on this box. Thus, if $|\Lambda_\beta| = e^{\theta\beta}$, then $L^* = L^*(\theta) = [\ell_c(\ell_c - 1) + 1] \wedge \min\{L \in \mathbb{N} : \Gamma_{L+1} - \Delta > \theta\}$, which increases stepwise from 1 to $\ell_c(\ell_c - 1) + 1$ as θ increases from Δ to Γ defined in (1.33).

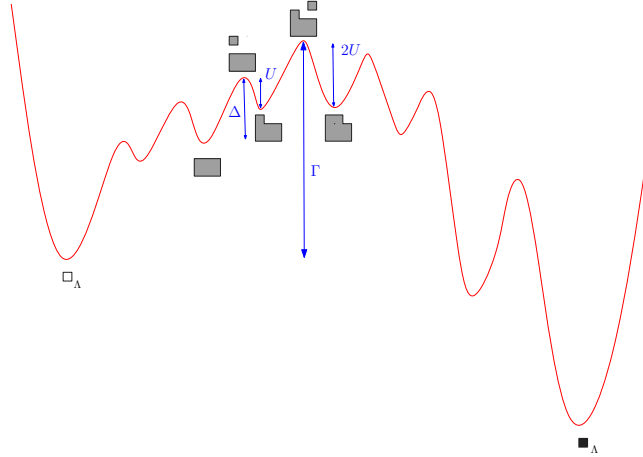

FIGURE 4. A nucleation path from \square_Λ to \blacksquare_Λ for Kawasaki dynamics on Λ with open boundary. Γ in (1.33) is the minimal energy barrier the path has to overcome under the local variant of the grand-canonical Hamiltonian in (1.24).

Set

$$\Gamma = -U[(\ell_c - 1)^2 + \ell_c(\ell_c - 1) + 1] + \Delta[\ell_c(\ell_c - 1) + 2], \quad (1.33)$$

which is the energy of a critical droplet at a given location with respect to the *grand-canonical* Hamiltonian given by (1.24) (see Figs. 3 and 4). Put $N = \frac{1}{3}\ell_c^2(\ell_c^2 - 1)$. For $M \in \mathbb{N}$ with $M \geq \ell_c$, define

$$\mathcal{D}_M = \{\sigma \in \mathcal{X}_\beta : \exists x \in \Lambda_\beta \text{ such that } \text{supp}[(\sigma)] \supset R_{M,M}(x)\}, \quad (1.34)$$

i.e., the set of configurations containing a supercritical droplet of size M . For our results below to be valid we need to assume that

$$\lim_{\beta \rightarrow \infty} |\Lambda_\beta| \rho_\beta = \infty, \quad \lim_{\beta \rightarrow \infty} |\Lambda_\beta| e^{-\beta\Gamma} = 0. \quad (1.35)$$

This first condition says that the number of particles tends to infinity, and ensures that the formation of a critical droplet somewhere does not globally deplete the surrounding gas.

Theorem 1.4. *In the regime (1.27), subject to (1.32) and (1.35), the following hold:*

(a)

$$\lim_{\beta \rightarrow \infty} |\Lambda_\beta| \frac{4\pi}{\beta\Delta} e^{-\beta\Gamma} \mathbb{E}_{\nu_{\mathcal{S}_L}^{(\mathcal{S}^c \setminus \tilde{\mathcal{C}}) \cup \mathcal{C}^+}} (\tau_{(\mathcal{S}^c \setminus \tilde{\mathcal{C}}) \cup \mathcal{C}^+}) = \frac{1}{N}. \quad (1.36)$$

(b)

$$\lim_{\beta \rightarrow \infty} |\Lambda_\beta| \frac{4\pi}{\beta\Delta} e^{-\beta\Gamma} \mathbb{E}_{\nu_{\mathcal{S}_L}^{\mathcal{D}_M}} (\tau_{\mathcal{D}_M}) = \frac{1}{N}, \quad \forall \ell_c \leq M \leq 2\ell_c - 1. \quad (1.37)$$

The proof of Theorem 1.4, which is the analog of Theorem 1.2, will be given in Section 4. Part (a) says that the average time to create a critical droplet is $[1+o(1)](\beta\Delta/4\pi)e^{\beta\Gamma}N|\Lambda_\beta|$. The factor $\beta\Delta/4\pi$ comes from the simple random walk that is performed by the free particle “from the gas to the proto-critical droplet” (i.e., the dynamics goes from \mathcal{C}^- to \mathcal{C}^+), which slows down the nucleation. The factor N counts the number of shapes of the proto-critical droplet (see Bovier, den Hollander, and Nardi [7]). Part (b) says that, once the critical droplet is created, it rapidly grows to a droplet that has twice the size.

Remarks: (1) As for Theorem 1.2(c), we expect Theorem 1.4(b) to hold for values of M that grow with β as $M = e^{o(\beta)}$. See Section 4.2 for more details.

(2) In Appendix D we will show that the *average* probability under the Gibbs measure μ_β of destroying a supercritical droplet and returning to a configuration in \mathcal{S}_L is exponentially small in β . Hence, the crossover from \mathcal{S}_L to $\mathcal{S}^c \setminus \tilde{\mathcal{C}} \cup \mathcal{C}^+$ represents the true threshold for nucleation, and Theorem 1.4(a) represents the true nucleation time.

(3) It was shown in Bovier, den Hollander, and Nardi [7] that the average crossover time in a finite box Λ equals

$$Ke^{\beta\Gamma}[1+o(1)], \quad \text{with } K = K(\Lambda, \ell_c) \sim \frac{\log |\Lambda|}{4\pi} \frac{1}{N|\Lambda|}, \quad \Lambda \rightarrow \mathbb{Z}^2. \quad (1.38)$$

This matches the $|\Lambda_\beta|$ -dependence in Theorem 1.4, with the logarithmic factor in (1.38) accounting for the extra factor $\beta\Delta$ in Theorem 1.4 compared to Theorem 1.2. Note that this factor is particularly interesting, since it says that the *effective box size* responsible for the formation of a critical droplet is L_β .

1.4. Outline. The remainder of this paper is organized as follows. In Section 2 we present a brief sketch of the basic ingredients of the potential-theoretic approach to metastability. In particular, we exhibit a *relation* between average crossover times and capacities, and we state *two variational representations* for capacities, the first of which is suitable for deriving upper bounds and the second for deriving lower bounds. Section 3 contains the proof of our results for the case of Glauber dynamics. This will be technically relatively easy, and will give a first flavor of how our method works. In Section 4 we deal with Kawasaki dynamics. Here we will encounter several rather more difficult issues, all coming from the fact that Kawasaki dynamics is *conservative*. The first is to understand why the constant Γ , representing the local energetic cost to create a critical droplet, involves the grand-canonical Hamiltonian, even though we are working in the canonical ensemble. This mystery will, of course, be resolved by the observation that the formation of a critical droplet reduces the entropy of the system: the precise computation of this entropy loss yields Γ via *equivalence of ensembles*. The second problem is to control the probability of a particle moving from the gas to the proto-critical droplet at the last stage of the nucleation. This non-locality issue will be dealt with via upper and lower estimates. Appendices A–D collect some technical lemmas that are needed in Sections 3–4.

The extension of our results to higher dimensions is limited only by the combinatorial problems involved in the computation of the number of critical droplets (which is hard in the case of Kawasaki dynamics) and of the probability for simple random walk to hit a critical droplet of a given shape when coming from far. We will not pursue this

generalization here. The relevant results on a β -independent box in \mathbb{Z}^3 can be found in Ben Arous and Cerf [1] (Glauber) and den Hollander, Nardi, Olivieri, and Scoppola [17] (Kawasaki). For recent overviews on droplet growth in metastability, we refer the reader to den Hollander [15, 16] and Bovier [4, 5]. A general overview on metastability is given in the monograph by Olivieri and Vares [23].

2. BASIC INGREDIENTS OF THE POTENTIAL-THEORETIC APPROACH

The proof of Theorems 1.2 and 1.4 uses the *potential-theoretic approach* to metastability developed in Bovier, Eckhoff, Gaynard and Klein [6]. This approach is based on the following three observations. First, most quantities of physical interest can be represented in term of Dirichlet problems associated with the generator of the dynamics. Second, the Green function of the dynamics can be expressed in terms of capacities and equilibrium potentials. Third, capacities satisfy variational principles that allow for obtaining upper and lower bounds in a flexible way. We will see that in the current setting the implementation of these observations provides very sharp results.

2.1. Equilibrium potential and capacity. The fundamental quantity in the theory is the *equilibrium potential*, $h_{\mathcal{A},\mathcal{B}}$, associated with two non-empty disjoint sets of configurations, $\mathcal{A}, \mathcal{B} \subset \mathcal{X}$ ($= \mathcal{X}_\beta$ or $\mathcal{X}_\beta^{(n_\beta)}$), which probabilistically is given by

$$h_{\mathcal{A},\mathcal{B}}(\sigma) = \begin{cases} \mathbb{P}_\sigma(\tau_{\mathcal{A}} < \tau_{\mathcal{B}}), & \text{for } \sigma \in (\mathcal{A} \cup \mathcal{B})^c, \\ 1, & \text{for } \sigma \in \mathcal{A}, \\ 0, & \text{for } \sigma \in \mathcal{B}, \end{cases} \quad (2.1)$$

where

$$\tau_{\mathcal{A}} = \inf\{t > 0: \sigma_t \in \mathcal{A}, \sigma_{t-} \notin \mathcal{A}\}, \quad (2.2)$$

$(\sigma_t)_{t \geq 0}$ is the continuous-time Markov chain with state space \mathcal{X} , and \mathbb{P}_σ is its law starting from σ . This function is *harmonic* and is the unique solution of the *Dirichlet problem*

$$\begin{aligned} (Lh_{\mathcal{A},\mathcal{B}})(\sigma) &= 0, & \sigma \in (\mathcal{A} \cup \mathcal{B})^c, \\ h_{\mathcal{A},\mathcal{B}}(\sigma) &= 1, & \sigma \in \mathcal{A}, \\ h_{\mathcal{A},\mathcal{B}}(\sigma) &= 0, & \sigma \in \mathcal{B}, \end{aligned} \quad (2.3)$$

where the generator is the matrix with entries

$$L(\sigma, \sigma') = c_\beta(\sigma, \sigma') - \delta_{\sigma, \sigma'} c_\beta(\sigma), \quad \sigma, \sigma' \in \mathcal{X}, \quad (2.4)$$

with $c_\beta(\sigma)$ the total rate at which the dynamics leaves σ ,

$$c_\beta(\sigma) = \sum_{\sigma' \in \mathcal{X} \setminus \{\sigma\}} c_\beta(\sigma, \sigma'), \quad \sigma \in \mathcal{X}. \quad (2.5)$$

A related quantity is the *equilibrium measure* on \mathcal{A} , which is defined as

$$e_{\mathcal{A},\mathcal{B}}(\sigma) = -(Lh_{\mathcal{A},\mathcal{B}})(\sigma), \quad \sigma \in \mathcal{A}. \quad (2.6)$$

The equilibrium measure also has a probabilistic meaning, namely,

$$\mathbb{P}_\sigma(\tau_{\mathcal{B}} < \tau_{\mathcal{A}}) = \frac{e_{\mathcal{A},\mathcal{B}}(\sigma)}{c_\beta(\sigma)}, \quad \sigma \in \mathcal{A}. \quad (2.7)$$

The key object we will work with is the *capacity*, which is defined as

$$\text{CAP}(\mathcal{A}, \mathcal{B}) = \sum_{\sigma \in \mathcal{A}} \mu_\beta(\sigma) e_{\mathcal{A},\mathcal{B}}(\sigma). \quad (2.8)$$

2.2. Relation between crossover time and capacity. The first important ingredient of the potential-theoretic approach to metastability is a formula for the average crossover time from \mathcal{A} to \mathcal{B} . To state this formula, we define the probability measure $\nu_{\mathcal{A}}^{\mathcal{B}}$ on \mathcal{A} we already referred to in Section 1, namely,

$$\nu_{\mathcal{A}}^{\mathcal{B}}(\sigma) = \begin{cases} \frac{\mu_{\beta}(\sigma)c_{\mathcal{A},\mathcal{B}}(\sigma)}{\text{CAP}(\mathcal{A},\mathcal{B})}, & \text{for } \sigma \in \mathcal{A}, \\ 0, & \text{for } \sigma \in \mathcal{A}^c. \end{cases} \quad (2.9)$$

The following proposition is proved e.g. in Bovier [5].

Proposition 2.1. *For any two non-empty disjoint sets $\mathcal{A}, \mathcal{B} \subset \mathcal{X}$,*

$$\sum_{\sigma \in \mathcal{A}} \nu_{\mathcal{A}}^{\mathcal{B}}(\sigma) \mathbb{E}_{\sigma}(\tau_{\mathcal{B}}) = \frac{1}{\text{CAP}(\mathcal{A}, \mathcal{B})} \sum_{\sigma \in \mathcal{B}^c} \mu_{\beta}(\sigma) h_{\mathcal{A},\mathcal{B}}(\sigma). \quad (2.10)$$

Remarks: (1) Due to (2.7–2.8), the probability measure $\nu_{\mathcal{A}}^{\mathcal{B}}(\sigma)$ can be written as

$$\nu_{\mathcal{A}}^{\mathcal{B}}(\sigma) = \frac{\mu_{\beta}(\sigma) c_{\beta}(\sigma)}{\text{CAP}(\mathcal{A}, \mathcal{B})} \mathbb{P}_{\sigma}(\tau_{\mathcal{B}} < \tau_{\mathcal{A}}), \quad \sigma \in \mathcal{A}, \quad (2.11)$$

and thus has the flavor of a *last-exit biased distribution*. Proposition 2.1 explains why our main results on average crossover times stated in Theorem 1.2 and 1.4 are formulated for this initial distribution. Note that

$$\mu_{\beta}(\mathcal{A}) \leq \sum_{\sigma \in \mathcal{B}^c} \mu_{\beta}(\sigma) h_{\mathcal{A},\mathcal{B}}(\sigma) \leq \mu_{\beta}(\mathcal{B}^c). \quad (2.12)$$

We will see that in our setting $\mu_{\beta}(\mathcal{B}^c \setminus \mathcal{A}) = o(\mu_{\beta}(\mathcal{A}))$ as $\beta \rightarrow \infty$, so that the sum in the right-hand side of (2.10) is $\sim \mu_{\beta}(\mathcal{A})$ and the computation of the crossover time reduces to the estimation of $\text{CAP}(\mathcal{A}, \mathcal{B})$.

(2) For a fixed target set \mathcal{B} , the choice of the starting set \mathcal{A} is free. It is tempting to choose $\mathcal{A} = \{\sigma\}$ for some $\sigma \in \mathcal{X}$. This was done for the case of a finite β -independent box Λ . However, in our case (and more generally in cases where the state space is large) such a choice would give intractable numerators and denominators in the right-hand side of (2.10). As a rule, to make use of the identity in (2.10), \mathcal{A} must be so large that the harmonic function $h_{\mathcal{A},\mathcal{B}}$ “does not change abruptly near the boundary of \mathcal{A} ” for the target set \mathcal{B} under consideration.

As noted above, average crossover times are essentially governed by capacities. The usefulness of this observation comes from the computability of capacities, as will be explained next.

2.3. The Dirichlet principle: A variational principle for upper bounds. The capacity is a boundary quantity, because $e_{\mathcal{A},\mathcal{B}} > 0$ only on the boundary of \mathcal{A} . The analog of Green’s identity relates it to a bulk quantity. Indeed, in terms of the *Dirichlet form* defined by

$$\mathcal{E}(h) = \frac{1}{2} \sum_{\sigma, \sigma' \in \mathcal{X}} \mu_{\beta}(\sigma) c_{\beta}(\sigma, \sigma') [h(\sigma) - h(\sigma')]^2, \quad h: \mathcal{X} \rightarrow [0, 1], \quad (2.13)$$

it follows, via (2.1) and (2.7–2.8), that

$$\text{CAP}(\mathcal{A}, \mathcal{B}) = \mathcal{E}(h_{\mathcal{A},\mathcal{B}}). \quad (2.14)$$

Elementary variational calculus shows that the capacity satisfies the *Dirichlet principle*:

Proposition 2.2. *For any two non-empty disjoint sets $\mathcal{A}, \mathcal{B} \subset \mathcal{X}$,*

$$\text{CAP}(\mathcal{A}, \mathcal{B}) = \min_{\substack{h: \mathcal{X} \rightarrow [0,1] \\ h|_{\mathcal{A}} \equiv 1, h|_{\mathcal{B}} \equiv 0}} \mathcal{E}(h). \quad (2.15)$$

The importance of the Dirichlet principle is that it yields *computable upper bounds* for capacities by suitable choices of the test function h . In metastable systems, with the proper physical insight it is often possible to guess a reasonable test function. In our setting this will be seen to be relatively easy.

2.4. The Berman-Konsowa principle: A variational principle for lower

bounds. We will describe a little-known variational principle for capacities that is originally due to Berman and Konsowa [2]. Our presentation will follow the argument given in Bianchi, Bovier, and Ioffe [3].

In the following it will be convenient to think of \mathcal{X} as the vertex-set of a graph $(\mathcal{X}, \mathcal{E})$ whose edge-set \mathcal{E} consists of all pairs (σ, σ') , $\sigma, \sigma' \in \mathcal{X}$, for which $c_\beta(\sigma, \sigma') > 0$.

Definition 2.3. *Given two non-empty disjoint sets $\mathcal{A}, \mathcal{B} \subset \mathcal{X}$, a loop-free non-negative unit flow, f , from \mathcal{A} to \mathcal{B} is a function $f: \mathcal{E} \rightarrow [0, \infty)$ such that:*

(a) $(f(e) > 0 \implies f(-e) = 0) \forall e \in \mathcal{E}$.

(b) f satisfies Kirchoff's law:

$$\sum_{\sigma' \in \mathcal{X}} f(\sigma, \sigma') = \sum_{\sigma'' \in \mathcal{X}} f(\sigma'', \sigma), \quad \forall \sigma \in \mathcal{X} \setminus (\mathcal{A} \cup \mathcal{B}). \quad (2.16)$$

(c) f is normalized:

$$\sum_{\sigma \in \mathcal{A}} \sum_{\sigma' \in \mathcal{X}} f(\sigma, \sigma') = 1 = \sum_{\sigma'' \in \mathcal{X}} \sum_{\sigma \in \mathcal{B}} f(\sigma'', \sigma). \quad (2.17)$$

(d) Any path from \mathcal{A} to \mathcal{B} along edges e such that $f(e) > 0$ is self-avoiding.

The space of all loop-free non-negative unit flows from \mathcal{A} to \mathcal{B} is denoted by $\mathbb{U}_{\mathcal{A}, \mathcal{B}}$.

A natural flow is the *harmonic flow*, which is constructed from the equilibrium potential $h_{\mathcal{A}, \mathcal{B}}$ as

$$f_{\mathcal{A}, \mathcal{B}}(\sigma, \sigma') = \frac{1}{\text{CAP}(\mathcal{A}, \mathcal{B})} \mu_\beta(\sigma) c_\beta(\sigma, \sigma') [h_{\mathcal{A}, \mathcal{B}}(\sigma) - h_{\mathcal{A}, \mathcal{B}}(\sigma')]_+, \quad \sigma, \sigma' \in \mathcal{X}. \quad (2.18)$$

It is easy to verify that $f_{\mathcal{A}, \mathcal{B}}$ satisfies (a–d). Indeed, (a) is obvious, (b) uses the harmonicity of $h_{\mathcal{A}, \mathcal{B}}$, (c) follows from (2.6) and (2.8), while (d) comes from the fact that the harmonic flow only moves in directions where $h_{\mathcal{A}, \mathcal{B}}$ decreases.

A loop-free non-negative unit flow f is naturally associated with a probability measure \mathbb{P}^f on self-avoiding paths, γ . To see this, define $F(\sigma) = \sum_{\sigma' \in \mathcal{X}} f(\sigma, \sigma')$, $\sigma \in \mathcal{X} \setminus \mathcal{B}$. Then \mathbb{P}^f is the Markov chain $(\sigma_n)_{n \in \mathbb{N}_0}$ with initial distribution $\mathbb{P}^f(\sigma_0) = F(\sigma_0) 1_{\mathcal{A}}(\sigma_0)$, transition probabilities

$$q^f(\sigma, \sigma') = \frac{f(\sigma, \sigma')}{F(\sigma)}, \quad \sigma \in \mathcal{X} \setminus \mathcal{B}, \quad (2.19)$$

such that the chain is stopped upon arrival in \mathcal{B} . In terms of this probability measure, we have the following proposition (see [3] for a proof).

Proposition 2.4. *Let $\mathcal{A}, \mathcal{B} \subset \mathcal{X}$ be two non-empty disjoint sets. Then, with the notation introduced above,*

$$\text{CAP}(\mathcal{A}, \mathcal{B}) = \sup_{f \in \mathbb{U}_{\mathcal{A}, \mathcal{B}}} \mathbb{E}^f \left(\left[\sum_{e \in \gamma} \frac{f(e_l, e_r)}{\mu_\beta(e_l) c_\beta(e_l, e_r)} \right]^{-1} \right), \quad (2.20)$$

where $e = (e_l, e_r)$ and the expectation is with respect to γ . Moreover, the supremum is realized for the harmonic flow $f_{\mathcal{A}, \mathcal{B}}$.

The nice feature of this variational principle is that any flow gives a *computable lower bound*. In this sense (2.15) and (2.20) complement each other. Moreover, since the harmonic flow is optimal, a good approximation of the harmonic function $h_{\mathcal{A},\mathcal{B}}$ by a test function h leads to a good approximation of the harmonic flow $f_{\mathcal{A},\mathcal{B}}$ by a test flow f after putting h instead of $h_{\mathcal{A},\mathcal{B}}$ in (2.18). Again, in metastable systems, with the proper physical insight it is often possible to guess a reasonable flow. We will see in Sections 3–4 how this is put to work in our setting.

3. PROOF OF THEOREM 1.2

3.1. Proof of Theorem 1.2(a). To estimate the average crossover time from $\mathcal{S}_L \subset \mathcal{S}$ to \mathcal{S}^c , we will use Proposition 2.1. With $\mathcal{A} = \mathcal{S}_L$ and $\mathcal{B} = \mathcal{S}^c$, (2.10) reads

$$\sum_{\sigma \in \mathcal{S}_L} \nu_{\mathcal{S}_L}^{\mathcal{S}^c}(\sigma) \mathbb{E}_\sigma(\tau_{\mathcal{S}^c}) = \frac{1}{\text{CAP}(\mathcal{S}_L, \mathcal{S}^c)} \sum_{\sigma \in \mathcal{S}} \mu_\beta(\sigma) h_{\mathcal{S}_L, \mathcal{S}^c}(\sigma). \quad (3.1)$$

The left-hand side is the quantity of interest in (1.16). In Sections 3.1.1–3.1.2 we estimate $\sum_{\sigma \in \mathcal{S}} \mu_\beta(\sigma) h_{\mathcal{S}_L, \mathcal{S}^c}(\sigma)$ and $\text{CAP}(\mathcal{S}_L, \mathcal{S}^c)$. The estimates will show that

$$\text{r.h.s. (3.1)} = \frac{1}{N_1 |\Lambda_\beta|} e^{\beta\Gamma} [1 + o(1)], \quad \beta \rightarrow \infty. \quad (3.2)$$

3.1.1. Estimate of $\sum_{\sigma \in \mathcal{S}} \mu_\beta(\sigma) h_{\mathcal{S}_L, \mathcal{S}^c}(\sigma)$.

Lemma 3.1. $\sum_{\sigma \in \mathcal{S}} \mu_\beta(\sigma) h_{\mathcal{S}_L, \mathcal{S}^c}(\sigma) = \mu_\beta(\mathcal{S}) [1 + o(1)]$ as $\beta \rightarrow \infty$.

Proof. Write, using (2.1),

$$\begin{aligned} \sum_{\sigma \in \mathcal{S}} \mu_\beta(\sigma) h_{\mathcal{S}_L, \mathcal{S}^c}(\sigma) &= \sum_{\sigma \in \mathcal{S}_L} \mu_\beta(\sigma) h_{\mathcal{S}_L, \mathcal{S}^c}(\sigma) + \sum_{\sigma \in \mathcal{S} \setminus \mathcal{S}_L} \mu_\beta(\sigma) h_{\mathcal{S}_L, \mathcal{S}^c}(\sigma) \\ &= \mu_\beta(\mathcal{S}_L) + \sum_{\sigma \in \mathcal{S} \setminus \mathcal{S}_L} \mu_\beta(\sigma) \mathbb{P}_\sigma(\tau_{\mathcal{S}_L} < \tau_{\mathcal{S}^c}). \end{aligned} \quad (3.3)$$

The last sum is bounded above by $\mu_\beta(\mathcal{S} \setminus \mathcal{S}_L)$. But $\mu_\beta(\mathcal{S} \setminus \mathcal{S}_L) = o(\mu_\beta(\mathcal{S}))$ as $\beta \rightarrow \infty$ by our choice of L in (1.9). \blacksquare

3.1.2. Estimate of $\text{CAP}(\mathcal{S}_L, \mathcal{S}^c)$.

Lemma 3.2. $\text{CAP}(\mathcal{S}_L, \mathcal{S}^c) = N_1 |\Lambda_\beta| e^{-\beta\Gamma} \mu_\beta(\mathcal{S}) [1 + o(1)]$ as $\beta \rightarrow \infty$ with $N_1 = 4\ell_c$.

Proof. The proof proceeds via upper and lower bounds.

Upper bound: We use the Dirichlet principle and a test function that is equal to 1 on \mathcal{S} to get the upper bound

$$\text{CAP}(\mathcal{S}_L, \mathcal{S}^c) \leq \text{CAP}(\mathcal{S}, \mathcal{S}^c) = \sum_{\substack{\sigma \in \mathcal{S}, \sigma' \in \mathcal{S}^c \\ c_\beta(\sigma, \sigma') > 0}} \mu_\beta(\sigma) c_\beta(\sigma, \sigma') = \sum_{\substack{\sigma \in \mathcal{S}, \sigma' \in \mathcal{S}^c \\ c_\beta(\sigma, \sigma') > 0}} [\mu_\beta(\sigma) \wedge \mu_\beta(\sigma')] \leq \mu_\beta(\mathcal{C}), \quad (3.4)$$

where the second equality uses (1.4) in combination with the fact that $c_\beta(\sigma, \sigma') \vee c_\beta(\sigma', \sigma) = 1$ by (1.3). Thus, it suffices to show that

$$\mu_\beta(\mathcal{C}) \leq N_1 |\Lambda_\beta| e^{-\beta\Gamma} [1 + o(1)] \quad \text{as } \beta \rightarrow \infty. \quad (3.5)$$

For every $\sigma \in \mathcal{P}$ there are one or more rectangles $R_{\ell_c-1, \ell_c}(x)$, $x = x(\sigma) \in \mathcal{X}_\beta$, that are filled by (+1)-spins in $C_B(\sigma)$. If $\sigma' \in \mathcal{C}$ is such that $\sigma' = \sigma^y$ for some $y \in \Lambda_\beta$, then σ' has a (+1)-spin at y situated on the boundary of one of these rectangles. Let

$$\begin{aligned} \hat{\mathcal{S}}(x) &= \{\sigma \in \mathcal{S} : \text{supp}[\sigma] \subseteq R_{\ell_c-1, \ell_c}(x)\}, \\ \check{\mathcal{S}}(x) &= \{\sigma \in \mathcal{S} : \text{supp}[\sigma] \subseteq [R_{\ell_c+1, \ell_c+2}(x - (1, 1))]^c\}. \end{aligned} \quad (3.6)$$

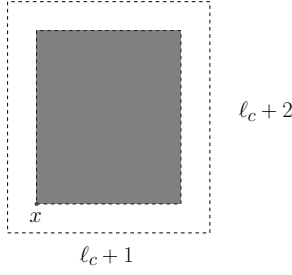

FIGURE 5. $R_{\ell_c-1, \ell_c}(x)$ (shaded box) and $[R_{\ell_c+1, \ell_c+2}(x - (1, 1))]^c$ (complement of dotted box).

For every $\sigma \in \mathcal{P}$, we have $\sigma = \hat{\sigma} \vee \check{\sigma}$ for some $\hat{\sigma} \in \hat{\mathcal{S}}(x)$ and $\check{\sigma} \in \check{\mathcal{S}}(x)$, uniquely decomposing the configuration into two non-interacting parts inside $R_{\ell_c-1, \ell_c}(x)$ and $[R_{\ell_c+1, \ell_c+2}(x - (1, 1))]^c$ (see Fig. 5). We have

$$H_\beta(\sigma) - H_\beta(\Xi) = [H_\beta(\hat{\sigma}) - H_\beta(\Xi)] + [H_\beta(\check{\sigma}) - H_\beta(\Xi)]. \quad (3.7)$$

Moreover, for any $y \notin \text{supp}[C_B(\sigma)]$, we have

$$H_\beta(\sigma^y) \geq H_\beta(\sigma) + 2J - h. \quad (3.8)$$

Hence

$$\begin{aligned} \mu_\beta(\mathcal{C}) &= \frac{1}{Z_\beta} \sum_{\sigma \in \mathcal{P}} \sum_{\substack{x \in \Lambda_\beta \\ \sigma^x \in \mathcal{C}}} e^{-\beta H_\beta(\sigma^x)} \\ &\leq \frac{1}{Z_\beta} N_1 e^{-\beta[2J-h-H_\beta(\Xi)]} \sum_{x \in \Lambda_\beta} \sum_{\check{\sigma} \in \check{\mathcal{S}}(x)} e^{-\beta H_\beta(\check{\sigma})} \sum_{\substack{\hat{\sigma} \in \hat{\mathcal{S}}(x) \\ \hat{\sigma} \vee \check{\sigma} \in \mathcal{P}}} e^{-\beta H_\beta(\hat{\sigma})} \\ &\leq [1 + o(1)] \frac{1}{Z_\beta} N_1 |\Lambda_\beta| e^{-\beta\Gamma} \sum_{\check{\sigma} \in \check{\mathcal{S}}(0)} e^{-\beta H_\beta(\check{\sigma})} \\ &= [1 + o(1)] N_1 |\Lambda_\beta| e^{-\beta\Gamma} \mu_\beta(\check{\mathcal{S}}(0)), \end{aligned} \quad (3.9)$$

where the first inequality uses (3.7–3.8), with $N_1 = 2 \times 2\ell_c = 4\ell_c$ counting the number of critical droplets that can arise from a proto-critical droplet via a spin flip (see Fig. 1), and the second inequality uses that

$$\hat{\sigma} \in \hat{\mathcal{S}}(0), \hat{\sigma} \vee \check{\sigma} \in \mathcal{P} \implies H_\beta(\hat{\sigma}) \geq H_\beta(R_{\ell_c-1, \ell_c}(0)) = \Gamma - (2J - h) + H_\beta(\Xi) \quad (3.10)$$

with equality in the right-hand side if and only if $\text{supp}[\hat{\sigma}] = R_{\ell_c-1, \ell_c}(0)$. Combining (3.4) and (3.9) with the inclusion $\check{\mathcal{S}}(0) \subset \mathcal{S}$, we get the upper bound in (3.5).

Lower bound: We exploit Proposition 2.4 by making a judicious choice for the flow f . In fact, in the Glauber case this choice will be simple: with each configuration $\sigma \in \mathcal{S}_L$ we associate a configuration in $\mathcal{C} \subset \mathcal{S}^c$ with a unique critical droplet and a flow that, from each such configuration, follows a unique *deterministic path* along which this droplet is broken down in the *canonical order* (see Fig. 6) until the set \mathcal{S}_L is reached, i.e., a square or quasi-square droplet with label L is left over (recall (1.7–1.8)).

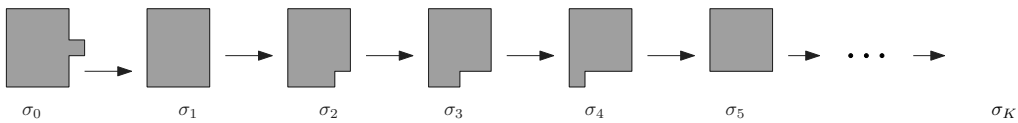

FIGURE 6. Canonical order to break down a critical droplet.

Let $f(\beta)$ be such that

$$\lim_{\beta \rightarrow \infty} f(\beta) = \infty, \quad \lim_{\beta \rightarrow \infty} \frac{1}{\beta} \log f(\beta) = 0, \quad \lim_{\beta \rightarrow \infty} |\Lambda_\beta|/f(\beta) = \infty, \quad (3.11)$$

and define

$$\mathcal{W} = \{\sigma \in \mathcal{S} : |\text{supp}[\sigma]| \leq |\Lambda_\beta|/f(\beta)\}. \quad (3.12)$$

Let $\mathcal{C}_L \subset \mathcal{C} \subset \mathcal{S}^c$ be the set of configurations obtained by picking any $\sigma \in \mathcal{S}_L \cap \mathcal{W}$ and adding somewhere in Λ_β a critical droplet at distance ≥ 2 from $\text{supp}[\sigma]$. Note that the density restriction imposed on \mathcal{W} guarantees that adding such a droplet is possible almost everywhere in Λ_β for β large enough. Denoting by $P_{(y)}(x)$ the critical droplet obtained by adding a protuberance at y along the longest side of the rectangle $R_{\ell_c-1, \ell_c}(x)$, we may write

$$\mathcal{C}_L = \{\sigma \cup P_{(y)}(x) : \sigma \in \mathcal{S} \cap \mathcal{W}, x, y \in \Lambda_\beta, (x, y) \perp \sigma\}, \quad (3.13)$$

where $(x, y) \perp \sigma$ stands for the restriction that the critical droplet $P_{(y)}(x)$ is not interacting with $\text{supp}[\sigma]$, which implies that $H_\beta(\sigma \cup P_{(y)}(x)) = H_\beta(\sigma) + \Gamma$ (see Figs. 7 and 8).

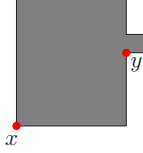

FIGURE 7. The critical droplet $P_{(y)}(x)$.

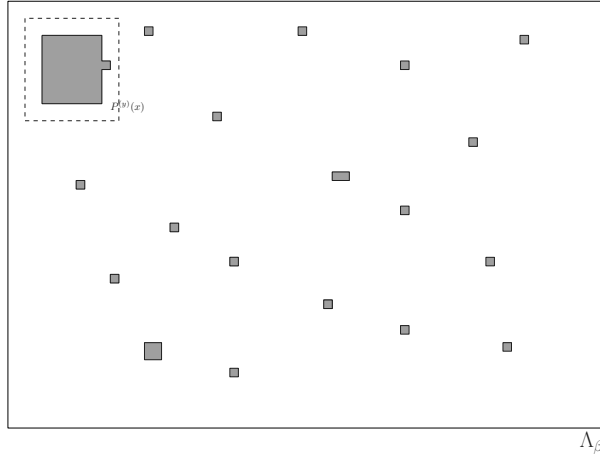

FIGURE 8. Going from \mathcal{S}_L to \mathcal{C}_L by adding a critical droplet $P_{(y)}(x)$ somewhere in Λ_β .

Now, for each $\sigma \in \mathcal{C}_L$, we let $\gamma_\sigma = (\gamma_\sigma(0), \gamma_\sigma(1), \dots, \gamma_\sigma(K))$ be the canonical path from $\sigma = \gamma_\sigma(0)$ to \mathcal{S}_L along which the critical droplet is broken down, where $K = v(2\ell_c - 3) - v(L)$ with

$$v(L) = |Q_L(0)| \quad (3.14)$$

(recall (1.7)). We will choose our flow such that

$$f(\sigma', \sigma'') = \begin{cases} \nu_0(\sigma), & \text{if } \sigma' = \sigma, \sigma'' = \gamma_\sigma(1) \text{ for some } \sigma \in \mathcal{C}_L, \\ \sum_{\tilde{\sigma} \in \mathcal{C}_L} f(\gamma_{\tilde{\sigma}}(k-1), \gamma_\sigma(k)), & \text{if } \sigma' = \gamma_\sigma(k), \sigma'' = \gamma_\sigma(k+1) \text{ for some } k \geq 1, \sigma \in \mathcal{C}_L, \\ 0, & \text{otherwise.} \end{cases} \quad (3.15)$$

Here, ν_0 is some initial distribution on \mathcal{C}_L that will turn out to be arbitrary as long as its support is all of \mathcal{C}_L .

We see from (3.15) that the flow increases whenever paths merge. In our case this happens only after the first step, when the protuberance at y is removed. Therefore we get the explicit form

$$f(\sigma', \sigma'') = \begin{cases} \nu_0(\sigma), & \text{if } \sigma' = \sigma, \sigma'' = \gamma_\sigma(1) \text{ for some } \sigma \in \mathcal{C}_L, \\ C\nu_0(\sigma), & \text{if } \sigma' = \gamma_\sigma(k), \sigma'' = \gamma_\sigma(k+1) \text{ for some } k \geq 1, \sigma \in \mathcal{C}_L, \\ 0, & \text{otherwise,} \end{cases} \quad (3.16)$$

where $C = 2\ell_c$ is the number of possible positions of the protuberance on the proto-critical droplet (see Fig. 6). Using Proposition 2.4, we therefore have

$$\begin{aligned} \text{CAP}(\mathcal{S}_L, \mathcal{S}^c) &= \text{CAP}(\mathcal{S}^c, \mathcal{S}_L) \geq \text{CAP}(\mathcal{C}_L, \mathcal{S}_L) \\ &\geq \sum_{\sigma \in \mathcal{C}_L} \nu_0(\sigma) \left[\sum_{k=0}^{K-1} \frac{f(\gamma_\sigma(k), \gamma_\sigma(k+1))}{\mu_\beta(\gamma_\sigma(k))c_\beta(\gamma_\sigma(k), \gamma_\sigma(k+1))} \right]^{-1} \\ &= \sum_{\sigma \in \mathcal{C}_L} \left[\frac{1}{\mu_\beta(\sigma)c_\beta(\gamma_\sigma(0), \gamma_\sigma(1))} + \sum_{k=1}^{K-1} \frac{C}{\mu_\beta(\gamma_\sigma(k))c_\beta(\gamma_\sigma(k), \gamma_\sigma(k+1))} \right]^{-1}. \end{aligned} \quad (3.17)$$

Thus, all we have to do is to control the sum between square brackets.

Because $c_\beta(\gamma_\sigma(0), \gamma_\sigma(1)) = 1$ (removing the protuberance lowers the energy), the term with $k = 0$ equals $1/\mu_\beta(\sigma)$. To show that the terms with $k \geq 1$ are of higher order, we argue as follows. Abbreviate $\Xi = h(\ell_c - 2)$. For every $k \geq 1$ and $\sigma(0) \in \mathcal{C}_L$, we have (see Fig. 9 and recall (1.2–1.3))

$$\mu_\beta(\gamma_\sigma(k))c_\beta(\gamma_\sigma(k), \gamma_\sigma(k+1)) = \frac{1}{Z_\beta} e^{-\beta[H_\beta(\gamma_\sigma(k)) \vee H_\beta(\gamma_\sigma(k+1))]} \geq \mu_\beta(\sigma_0) e^{\beta[2J - h - \Xi]} = \mu_\beta(\sigma) e^{\beta\delta}, \quad (3.18)$$

where $\delta = 2J - h - \Xi = 2J - h(\ell_c - 1) > 0$ (recall (1.6)). Therefore

$$\sum_{k=1}^{K-1} \frac{C}{\mu_\beta(\gamma_\sigma(k))c_\beta(\gamma_\sigma(k), \gamma_\sigma(k+1))} \leq \frac{1}{\mu_\beta(\sigma)} CK e^{-\delta\beta}, \quad (3.19)$$

and so from (3.17) we get

$$\text{CAP}(\mathcal{S}_L, \mathcal{S}^c) \geq \sum_{\sigma \in \mathcal{C}_L} \frac{\mu_\beta(\sigma)}{1 + CK e^{-\delta\beta}} = \frac{\mu_\beta(\mathcal{C}_L)}{1 + CK e^{-\delta\beta}} = [1 + o(1)] \mu_\beta(\mathcal{C}_L). \quad (3.20)$$

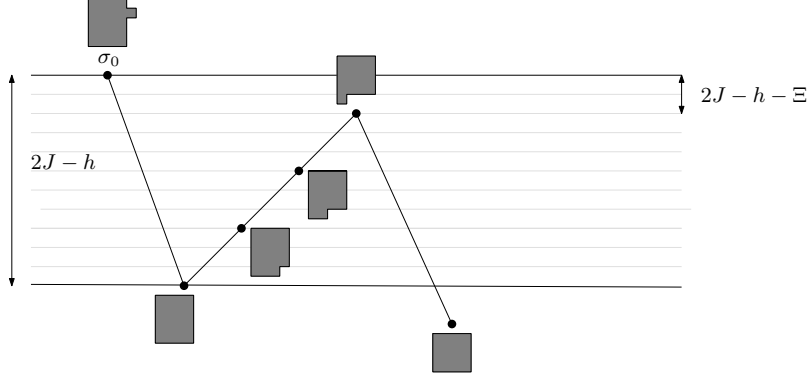

FIGURE 9. Visualization of (3.18).

The last step is to estimate, with the help of (3.13),

$$\begin{aligned}
\mu_\beta(\mathcal{C}_L) &= \frac{1}{Z_\beta} \sum_{\sigma \in \mathcal{C}_L} e^{-\beta H_\beta(\sigma)} = \frac{1}{Z_\beta} \sum_{\sigma \in \mathcal{S}_L \cap \mathcal{W}} \sum_{\substack{x, y \in \Lambda_\beta \\ (x, y) \perp \sigma}} e^{-\beta H_\beta(\sigma \cup P_{(y)}(x))} \\
&= e^{-\beta \Gamma} \frac{1}{Z_\beta} \sum_{\sigma \in \mathcal{S}_L \cap \mathcal{W}} e^{-\beta H_\beta(\sigma)} \sum_{\substack{x, y \in \Lambda_\beta \\ (x, y) \perp \sigma}} 1 \\
&\geq e^{-\beta \Gamma} \mu_\beta(\mathcal{S}_L \cap \mathcal{W}) N_1 |\Lambda_\beta| [1 - (\ell_c + 1)^2 / f(\beta)].
\end{aligned} \tag{3.21}$$

The last inequality uses that $|\Lambda_\beta|(\ell_c + 1)^2 / f(\beta)$ is the maximal number of sites in Λ_β where it is not possible to insert a non-interacting critical droplet (recall (3.12) and note that a critical droplet fits inside an $\ell_c \times \ell_c$ square). According to Lemma A.1 in Appendix A, we have

$$\mu_\beta(\mathcal{S}_L \cap \mathcal{W}) = \mu_\beta(\mathcal{S}_L)[1 + o(1)], \tag{3.22}$$

while conditions (1.8–1.9) imply that $\mu_\beta(\mathcal{S}_L) = \mu_\beta(\mathcal{S})[1 + o(1)]$. Combining the latter with (3.20–3.21), we obtain the desired lower bound. \blacksquare

3.2. Proof of Theorem 1.2(b). We use the same technique as in Section 3.1, which is why we only give a sketch of the proof.

To estimate the average crossover time from $\mathcal{S}_L \subset \mathcal{S}$ to $\mathcal{S}^c \setminus \mathcal{C}$, we will use Proposition 2.1. With $\mathcal{A} = \mathcal{S}_L$ and $\mathcal{B} = \mathcal{S}^c \setminus \mathcal{C}$, (2.10) reads

$$\sum_{\sigma \in \mathcal{S}_L} \nu_{\mathcal{S}_L}^{\mathcal{S}^c \setminus \mathcal{C}}(\sigma) \mathbb{E}_\sigma(\tau_{\mathcal{S}^c \setminus \mathcal{C}}) = \frac{1}{\text{CAP}(\mathcal{S}_L, \mathcal{S}^c \setminus \mathcal{C})} \sum_{\sigma \in \mathcal{S} \cup \mathcal{C}} \mu_\beta(\sigma) h_{\mathcal{S}_L, \mathcal{S}^c \setminus \mathcal{C}}(\sigma). \tag{3.23}$$

The left-hand side is the quantity of interest in (1.17).

In Sections 3.2.1–3.2.2 we estimate $\sum_{\sigma \in \mathcal{S} \cup \mathcal{C}} \mu_\beta(\sigma) h_{\mathcal{S}_L, \mathcal{S}^c \setminus \mathcal{C}}(\sigma)$ and $\text{CAP}(\mathcal{S}_L, \mathcal{S}^c \setminus \mathcal{C})$. The estimates will show that

$$\text{r.h.s. (3.23)} = \frac{1}{N_2 |\Lambda_\beta|} e^{\beta \Gamma} [1 + o(1)], \quad \beta \rightarrow \infty. \tag{3.24}$$

3.2.1. Estimate of $\sum_{\sigma \in \mathcal{S} \cup \mathcal{C}} \mu_\beta(\sigma) h_{\mathcal{S}_L, \mathcal{S}^c \setminus \mathcal{C}}(\sigma)$.

Lemma 3.3. $\sum_{\sigma \in \mathcal{S} \cup \mathcal{C}} \mu_\beta(\sigma) h_{\mathcal{S}_L, \mathcal{S}^c \setminus \mathcal{C}}(\sigma) = \mu_\beta(\mathcal{S})[1 + o(1)]$ as $\beta \rightarrow \infty$.

Proof. Write, using (2.1),

$$\sum_{\sigma \in \mathcal{S} \cup \mathcal{C}} \mu_\beta(\sigma) h_{\mathcal{S}_L, \mathcal{S}^c \setminus \mathcal{C}}(\sigma) = \mu_\beta(\mathcal{S}_L) + \sum_{\sigma \in (\mathcal{S} \setminus \mathcal{S}_L) \cup \mathcal{C}} \mu_\beta(\sigma) \mathbb{P}_\sigma(\tau_{\mathcal{S}_L} < \tau_{\mathcal{S}^c \setminus \mathcal{C}}). \tag{3.25}$$

The last sum is bounded above by $\mu_\beta(\mathcal{S} \setminus \mathcal{S}_L) + \mu_\beta(\mathcal{C})$. As before, $\mu_\beta(\mathcal{S} \setminus \mathcal{S}_L) = o(\mu_\beta(\mathcal{S}))$ as $\beta \rightarrow \infty$. But (1.35) and (3.9) imply that $\mu_\beta(\mathcal{C}) = o(\mu_\beta(\mathcal{S}))$ as $\beta \rightarrow \infty$. \blacksquare

3.2.2. Estimate of $\text{CAP}(\mathcal{S}_L, \mathcal{S}^c \setminus \mathcal{C})$.

Lemma 3.4. $\text{CAP}(\mathcal{S}, \mathcal{S}^c \setminus \mathcal{C}) = N_2 |\Lambda_\beta| e^{-\beta \Gamma} \mu_\beta(\mathcal{S}) [1 + o(1)]$ as $\beta \rightarrow \infty$ with $N_2 = \frac{4}{3}(2\ell_c - 1)$.

Proof. The proof is similar as that of Lemma 3.2, except that it takes care of the transition probabilities away from the critical droplet.

Upper bound: Recalling (2.13–2.15) and noting that Glauber dynamics does not allow transitions within \mathcal{C} , we have, for all $h: \mathcal{C} \rightarrow [0, 1]$,

$$\text{CAP}(\mathcal{S}_L, \mathcal{S}^c \setminus \mathcal{C}) \leq \text{CAP}(\mathcal{S}, \mathcal{S}^c \setminus \mathcal{C}) \leq \sum_{\sigma \in \mathcal{C}} \mu_\beta(\sigma) [\hat{c}_\sigma (h(\sigma) - 1)^2 + \check{c}_\sigma (h(\sigma) - 0)^2], \quad (3.26)$$

where $\hat{c}_\sigma = \sum_{\eta \in \mathcal{S}} c_\beta(\sigma, \eta)$ and $\check{c}_\sigma = \sum_{\eta \in \mathcal{S}^c \setminus \mathcal{C}} c_\beta(\sigma, \eta)$. The quadratic form in the right-hand side of (3.26) achieves its minimum for $h(\sigma) = \hat{c}_\sigma / (\hat{c}_\sigma + \check{c}_\sigma)$, so

$$\text{CAP}(\mathcal{S}_L, \mathcal{S}^c \setminus \mathcal{C}) \leq \sum_{\sigma \in \mathcal{C}} C_\sigma \mu_\beta(\sigma) \quad (3.27)$$

with $C_\sigma = \hat{c}_\sigma \check{c}_\sigma / (\hat{c}_\sigma + \check{c}_\sigma)$. We have

$$\begin{aligned} \sum_{\sigma \in \mathcal{C}} C_\sigma \mu_\beta(\sigma) &= \frac{1}{Z_\beta} \sum_{\sigma \in \mathcal{P}} \sum_{\substack{x \in \Lambda_\beta \\ \sigma^x \in \mathcal{C}}} C_{\sigma^x} e^{-\beta H_\beta(\sigma^x)} \\ &= e^{-\beta(2J-h)} \frac{1}{Z_\beta} \sum_{\sigma \in \mathcal{P}} e^{-\beta H_\beta(\sigma)} 2 \left(\frac{1}{2} 4 + \frac{2}{3} (2\ell_c - 4) \right) \\ &= e^{-\beta(2J-h)} \mu_\beta(\mathcal{P}) N_2 = \frac{1}{N_1} \mu_\beta(\mathcal{C}) N_2, \end{aligned} \quad (3.28)$$

where in the second line we use that $C_\sigma = \frac{1}{2}$ if σ has a protuberance in a corner (2×4 choices) and $C_\sigma = \frac{2}{3}$ otherwise ($2 \times (2\ell_c - 4)$ choices).

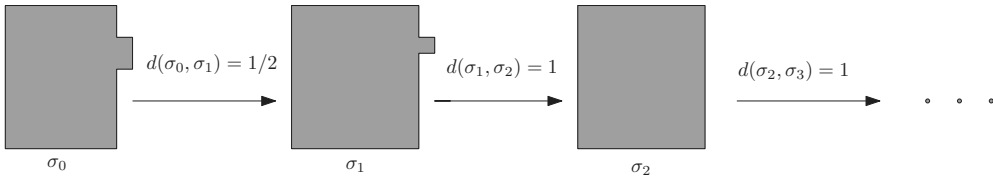

FIGURE 10. Canonical order to break down a proto-critical droplet plus a double protuberance. In the first step, the double protuberance has probability $\frac{1}{2}$ to be broken down in either of the two possible ways. The subsequent steps are deterministic as in Fig. 6.

Lower bound: In analogy with (3.13), denoting by $P_{(y)}^2(x)$ the droplet obtained by adding a double protuberance at y along the longest side of the rectangle $R_{\ell_c-1, \ell_c}(x)$, we define the set $\mathcal{D}_L \subset \mathcal{S}^c \setminus \mathcal{C}$ by

$$\mathcal{D}_L = \{\sigma \cup P_{(y)}^2(x) : \sigma \in \mathcal{S}_L \cap \mathcal{W}, x, y \in \Lambda_\beta, (x, y) \perp \sigma\}. \quad (3.29)$$

As in (3.15), we may choose any starting measure on \mathcal{D}_L . We choose the flow as follows. For the first step we choose

$$f(\sigma', \sigma) = \frac{1}{2} \nu_0(\sigma), \quad \sigma' \in \mathcal{D}_L, \sigma \in \mathcal{C}_L, \quad (3.30)$$

which reduces the double protuberance to a single protuberance (compare (3.13) and (3.29)). For all subsequent steps we follow the deterministic paths γ_σ used in Section 3.1.2, which start from $\gamma_\sigma(0) = \sigma$. Note, however, that we get different values for the flows $f(\gamma_\sigma(0), \gamma_\sigma(1))$ depending on whether the protuberance sits in a corner or not. In the former case, it has only one possible antecedent, and so

$$f(\gamma_\sigma(0), \gamma_\sigma(1)) = \frac{1}{2} \nu_0(\sigma), \quad (3.31)$$

while in the latter case it has two antecedents, and so

$$f(\gamma_\sigma(0), \gamma_\sigma(1)) = \nu_0(\sigma). \quad (3.32)$$

This time the terms $k = 0$ and $k = 1$ are of the same order while, as in (3.19), all the subsequent steps give a contribution that is a factor $O(e^{-\delta\beta})$ smaller. Indeed, in analogy with (3.17) we obtain, writing $\sigma \sim \sigma'$ when $c_\beta(\sigma', \sigma) > 0$,

$$\begin{aligned} \text{CAP}(\mathcal{S}_L, \mathcal{S}^c \setminus \mathcal{C}) &= \text{CAP}(\mathcal{S}^c \setminus \mathcal{C}, \mathcal{S}_L) \geq \text{CAP}(\mathcal{D}_L, \mathcal{S}_L) \\ &\geq \sum_{\sigma' \in \mathcal{D}_L} \frac{1}{2} \sum_{\substack{\sigma \in \mathcal{C}_L \\ \sigma \sim \sigma'}} \left[\frac{f(\sigma', \sigma)}{\mu_\beta(\sigma)} + \frac{f(\sigma, \gamma_\sigma(1))}{\mu_\beta(\sigma)} + \sum_{k=1}^{K-1} \frac{f(\gamma_\sigma(k), \gamma_\sigma(k+1))}{\mu_\beta(\gamma_\sigma(k)) c_\beta(\gamma_\sigma(k), \gamma_\sigma(k+1))} \right]^{-1} \\ &\geq \sum_{\sigma' \in \mathcal{D}_L} \frac{1}{2} \sum_{\substack{\sigma \in \mathcal{C}_L \\ \sigma \sim \sigma'}} \mu_\beta(\sigma) \left[f(\sigma', \sigma) + f(\sigma, \gamma_\sigma(1)) + CK e^{-\beta\delta} \right]^{-1} \\ &= [1 + o(1)] \mu_\beta(\mathcal{C}_L) \left(\frac{2\ell_c - 4}{2\ell_c} \frac{1}{1 + \frac{1}{2}} + \frac{1}{2} \frac{4}{2\ell_c} \frac{1}{\frac{1}{2} + \frac{1}{2}} \right) \\ &= [1 + o(1)] \mu_\beta(\mathcal{C}_L) \frac{N_2}{N_1}. \end{aligned} \quad (3.33)$$

Using (3.21) and the remarks following it, we get the desired lower bound. \blacksquare

3.3. Proof of Theorem 1.2(c). Write

$$\begin{aligned} \sum_{\sigma \in \mathcal{D}_M^c} \mu_\beta(\sigma) h_{\mathcal{S}_L, \mathcal{D}_M}(\sigma) &= \sum_{\sigma \in \mathcal{S}_L} \mu_\beta(\sigma) h_{\mathcal{S}_L, \mathcal{D}_M}(\sigma) + \sum_{\sigma \in \mathcal{D}_M^c \setminus \mathcal{S}_L} \mu_\beta(\sigma) h_{\mathcal{S}_L, \mathcal{D}_M}(\sigma) \\ &= \mu_\beta(\mathcal{S}_L) + \sum_{\sigma \in \mathcal{D}_M^c \setminus \mathcal{S}_L} \mu_\beta(\sigma) \mathbb{P}_\sigma(\tau_{\mathcal{S}_L} < \tau_{\mathcal{D}_M}). \end{aligned} \quad (3.34)$$

The last sum is bounded above by $\mu_\beta(\mathcal{S} \setminus \mathcal{S}_L) + \mu_\beta(\mathcal{D}_M^c \setminus \mathcal{S})$. But $\mu_\beta(\mathcal{S} \setminus \mathcal{S}_L) = o(\mu_\beta(\mathcal{S}))$ as $\beta \rightarrow \infty$ by our choice of L in (1.9), while $\mu_\beta(\mathcal{D}_M^c \setminus \mathcal{S}) = o(\mu_\beta(\mathcal{S}))$ as $\beta \rightarrow \infty$ because of the restriction $\ell_c \leq M2\ell_c - 1$. Indeed, under that restriction the energy of a square droplet of size M is strictly larger than the energy of a critical droplet.

Proof. The proof of Theorem 1.2(c) follows along the same lines as that of Theorems 1.2(a–b) in Sections 3.1–3.2. The main point is to prove that $\text{CAP}(\mathcal{S}_L, \mathcal{D}_M) = [1 + o(1)] \text{CAP}(\mathcal{S}_L, \mathcal{S}^c \setminus \mathcal{C})$. Since $\text{CAP}(\mathcal{S}_L, \mathcal{D}_M) \leq \text{CAP}(\mathcal{S}_L, \mathcal{S}^c \setminus \mathcal{C})$, which was estimated in Section 3.2, we need only prove a lower bound on $\text{CAP}(\mathcal{S}_L, \mathcal{D}_M)$. This is done by using a flow that breaks down an $M \times M$ droplet to a square or quasi-square droplet Q_L in the canonical way, which takes $M^2 - v(L)$ steps (recall Fig. 6 and (3.14)). The leading terms are still the proto-critical droplet with a single and a double protuberance. To each $M \times M$ droplet is associated a unique critical droplet, so that the pre-factor in the lower bound is the same as in the proof of Theorem 1.2(b).

Note that we can even allow M to grow with β as $M = e^{o(\beta)}$. Indeed, (3.11–3.12) show that there is room enough to add a droplet of size $e^{o(\beta)}$ almost everywhere in Λ_β , and the factor $M^2 e^{-\delta\beta}$ replacing $Ke^{-\delta\beta}$ in (3.20) still is $o(1)$. \blacksquare

4. PROOF OF THEOREM 1.4

4.1. Proof of Theorem 1.4(a).

4.1.1. *Estimate of $\sum_{\sigma \in \mathcal{S} \cup (\tilde{\mathcal{C}} \setminus \mathcal{C}^+)} \mu_\beta(\sigma) h_{\mathcal{S}_L, (\mathcal{S}^c \setminus \tilde{\mathcal{C}}) \cup \mathcal{C}^+}(\sigma)$.*

Lemma 4.1. $\sum_{\sigma \in \mathcal{S} \cup (\tilde{\mathcal{C}} \setminus \mathcal{C}^+)} \mu_\beta(\sigma) h_{\mathcal{S}_L, (\mathcal{S}^c \setminus \tilde{\mathcal{C}}) \cup \mathcal{C}^+}(\sigma) = \mu_\beta(\mathcal{S})[1 + o(1)]$ as $\beta \rightarrow \infty$.

Proof. Write, using (2.1),

$$\begin{aligned} & \sum_{\sigma \in \mathcal{S} \cup (\tilde{\mathcal{C}} \setminus \mathcal{C}^+)} \mu_\beta(\sigma) h_{\mathcal{S}_L, (\mathcal{S}^c \setminus \tilde{\mathcal{C}}) \cup \mathcal{C}^+}(\sigma) \\ &= \mu_\beta(\mathcal{S}_L) + \sum_{\sigma \in (\mathcal{S} \setminus \mathcal{S}_L) \cup (\tilde{\mathcal{C}} \setminus \mathcal{C}^+)} \mu_\beta(\sigma) \mathbb{P}_\sigma(\tau_{\mathcal{S}_L} < \tau_{(\mathcal{S}^c \setminus \tilde{\mathcal{C}}) \cup \mathcal{C}^+}). \end{aligned} \quad (4.1)$$

The last sum is bounded above by $\mu_\beta(\mathcal{S} \setminus \mathcal{S}_L) + \mu_\beta(\tilde{\mathcal{C}} \setminus \mathcal{C}^+)$. But $\mu_\beta(\mathcal{S} \setminus \mathcal{S}_L) = o(\mu_\beta(\mathcal{S}))$ as $\beta \rightarrow \infty$ by our choice of L in (1.32). In Lemma B.3 in Appendix B.3 we will show that $\mu_\beta(\tilde{\mathcal{C}} \setminus \mathcal{C}^+) = o(\mu_\beta(\mathcal{S}))$ as $\beta \rightarrow \infty$. ■

4.1.2. *Estimate of $\text{CAP}(\mathcal{S}_L, (\mathcal{S}^c \setminus \tilde{\mathcal{C}}) \cup \mathcal{C}^+)$.*

Lemma 4.2. $\text{CAP}(\mathcal{S}_L, \mathcal{S}^c \setminus \tilde{\mathcal{C}} \cup \mathcal{C}^+) = N |\Lambda_\beta| \frac{4\pi}{\beta \Delta} e^{-\beta \Gamma} \mu_\beta(\mathcal{S}) [1 + o(1)]$ as $\beta \rightarrow \infty$ with $N = \frac{1}{3} \ell_c^2 (\ell_c^2 - 1)$.

Proof. The argument is in the same spirit as that in Section 3.1.2. However, a number of additional hurdles need to be taken that come from the conservative nature of Kawasaki dynamics. The proof proceeds via upper and lower bounds, and takes up quite a bit of space.

Upper bound: The proof comes in 7 steps.

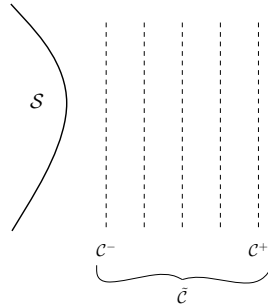

FIGURE 11. Schematic picture of the sets \mathcal{S} , \mathcal{C}^- , \mathcal{C}^+ defined in Definition 1.3 and the set $\tilde{\mathcal{C}}$ interpolating between \mathcal{C}^- and \mathcal{C}^+ .

1. Proto-critical droplet and free particle. Let $\tilde{\mathcal{C}}$ denote the set of configurations “interpolating” between \mathcal{C}^- and \mathcal{C}^+ , in the sense that the free particle is somewhere between the boundary of the proto-critical droplet and the boundary of the box of size L_β around the proto-critical droplet (see Fig. 11). Then we have

$$\begin{aligned} \text{CAP}(\mathcal{S}_L, (\mathcal{S}^c \setminus \tilde{\mathcal{C}}) \cup \mathcal{C}^+) &\leq \text{CAP}(\mathcal{S} \cup \mathcal{C}^-, (\mathcal{S}^c \setminus \tilde{\mathcal{C}}) \cup \mathcal{C}^+) \\ &= \min_{\substack{h: \mathcal{X}_\beta^{(n_\beta)} \rightarrow [0,1] \\ h|_{\mathcal{S} \cup \mathcal{C}^-} \equiv 1, h|_{(\mathcal{S}^c \setminus \tilde{\mathcal{C}}) \cup \mathcal{C}^+} \equiv 0}} \frac{1}{2} \sum_{\sigma, \sigma' \in \mathcal{X}_\beta^{(n_\beta)}} \mu_\beta(\sigma) c_\beta(\sigma, \sigma') [h(\sigma) - h(\sigma')]^2. \end{aligned} \quad (4.2)$$

Split the right-hand side into a contribution coming from $\sigma, \sigma' \in \tilde{\mathcal{C}}$ and the rest:

$$\text{r.h.s.}(4.2) = I + \gamma_1(\beta), \quad (4.3)$$

where

$$I = \min_{\substack{h: \tilde{\mathcal{C}} \rightarrow [0,1] \\ h|_{\mathcal{C}^-} \equiv 1, h|_{\mathcal{C}^+} \equiv 0}} \frac{1}{2} \sum_{\sigma, \sigma' \in \tilde{\mathcal{C}}} \mu_\beta(\sigma) c_\beta(\sigma, \sigma') [h(\sigma) - h(\sigma')]^2 \quad (4.4)$$

and $\gamma_1(\beta)$ is an error term that will be estimated in Step 7. This term will turn out to be small because $\mu_\beta(\sigma) c_\beta(\sigma, \sigma')$ is small when either $\sigma \in \mathcal{X}_\beta^{(n_\beta)} \setminus \tilde{\mathcal{C}}$ or $\sigma' \in \mathcal{X}_\beta^{(n_\beta)} \setminus \tilde{\mathcal{C}}$. Next, partition $\tilde{\mathcal{C}}, \mathcal{C}^-, \mathcal{C}^+$ into sets $\tilde{\mathcal{C}}(x), \mathcal{C}^-(x), \mathcal{C}^+(x)$, $x \in \Lambda_\beta$, by requiring that the lower-left corner of the proto-critical droplet is in the center of the box $B_{L_\beta, L_\beta}(x)$. Then, because $c_\beta(\sigma, \sigma') = 0$ when $\sigma \in \tilde{\mathcal{C}}(x)$ and $\sigma' \in \tilde{\mathcal{C}}(x')$ for some $x \neq x'$, we may write

$$I = |\Lambda_\beta| \min_{\substack{h: \tilde{\mathcal{C}}(0) \rightarrow [0,1] \\ h|_{\mathcal{C}^-(0)} \equiv 1, h|_{\mathcal{C}^+(0)} \equiv 0}} \frac{1}{2} \sum_{\sigma, \sigma' \in \tilde{\mathcal{C}}(0)} \mu_\beta(\sigma) c_\beta(\sigma, \sigma') [h(\sigma) - h(\sigma')]^2. \quad (4.5)$$

2. Decomposition of configurations. Define (compare with (3.6))

$$\begin{aligned} \hat{\mathcal{C}}(0) &= \{\sigma \mathbb{1}_{B_{L_\beta, L_\beta}(0)} : \sigma \in \tilde{\mathcal{C}}(0)\}, \\ \check{\mathcal{C}}(0) &= \{\sigma \mathbb{1}_{[B_{L_\beta, L_\beta}(0)]^c} : \sigma \in \tilde{\mathcal{C}}(0)\}. \end{aligned} \quad (4.6)$$

Then every $\sigma \in \tilde{\mathcal{C}}(0)$ can be uniquely decomposed as $\sigma = \hat{\sigma} \vee \check{\sigma}$ for some $\hat{\sigma} \in \hat{\mathcal{C}}(0)$ and $\check{\sigma} \in \check{\mathcal{C}}(0)$. Note that $\hat{\mathcal{C}}(0)$ has $K = \ell_c(\ell_c - 1) + 2$ particles and $\check{\mathcal{C}}(0)$ has $n_\beta - K$ particles (and recall that, by the first half of (1.35), $n_\beta \rightarrow \infty$ as $\beta \rightarrow \infty$). Define

$$\mathcal{C}^{\text{fp}}(0) = \{\sigma \in \tilde{\mathcal{C}}(0) : H_\beta(\sigma) = H_\beta(\hat{\sigma}) + H_\beta(\check{\sigma})\}, \quad (4.7)$$

i.e., the set of configurations consisting of a proto-critical droplet and a free particle inside $B_{L_\beta, L_\beta}(0)$ not interacting with the particles outside $B_{L_\beta, L_\beta}(0)$. Write $\mathcal{C}^{\text{fp}, -}(0)$ and $\mathcal{C}^{\text{fp}, +}(0)$ to denoting the subsets of $\mathcal{C}^{\text{fp}}(0)$ where the free particle is at distance L_β , respectively, 2 from the proto-critical droplet. Split the right-hand side of (4.5) into a contribution coming from $\sigma, \sigma' \in \mathcal{C}^{\text{fp}}(0)$ and the rest:

$$\text{r.h.s.}(4.5) = |\Lambda_\beta| [II + \gamma_2(\beta)], \quad (4.8)$$

where

$$II = \min_{\substack{h: \mathcal{C}^{\text{fp}}(0) \rightarrow [0,1] \\ h|_{\mathcal{C}^{\text{fp}, -}(0)} \equiv 1, h|_{\mathcal{C}^{\text{fp}, +}(0)} \equiv 0}} \frac{1}{2} \sum_{\sigma, \sigma' \in \mathcal{C}^{\text{fp}}(0)} \mu_\beta(\sigma) c_\beta(\sigma, \sigma') [h(\sigma) - h(\sigma')]^2 \quad (4.9)$$

and $\gamma_2(\beta)$ is an error term that will be estimated in Step 6. This term will turn out to be small because of loss of entropy when the particle is at the boundary.

3. Reduction to capacity of simple random walk. Estimate

$$\begin{aligned} II &= \min_{\substack{h: \mathcal{C}^{\text{fp}}(0) \rightarrow [0,1] \\ h|_{\mathcal{C}^{\text{fp}, -}(0)} \equiv 1, h|_{\mathcal{C}^{\text{fp}, +}(0)} \equiv 0}} \\ &\quad \frac{1}{2} \sum_{\check{\sigma}, \check{\sigma}' \in \check{\mathcal{C}}(0)} \sum_{\substack{\hat{\sigma}, \hat{\sigma}' \in \hat{\mathcal{C}}(0): \\ \hat{\sigma} \vee \check{\sigma}, \hat{\sigma}' \vee \check{\sigma}' \in \mathcal{C}^{\text{fp}}(0)}} \mu_\beta(\hat{\sigma} \vee \check{\sigma}) c_\beta(\hat{\sigma} \vee \check{\sigma}, \hat{\sigma}' \vee \check{\sigma}') [h(\hat{\sigma} \vee \check{\sigma}) - h(\hat{\sigma}' \vee \check{\sigma}')]^2 \\ &\leq \min_{\substack{g: \hat{\mathcal{C}}(0) \rightarrow [0,1] \\ g|_{\hat{\mathcal{C}}^-(0)} \equiv 1, g|_{\hat{\mathcal{C}}^+(0)} \equiv 0}} \\ &\quad \frac{1}{2} \sum_{\check{\sigma} \in \check{\mathcal{C}}(0)} \sum_{\substack{\hat{\sigma}, \hat{\sigma}' \in \hat{\mathcal{C}}(0): \\ \hat{\sigma} \vee \check{\sigma}, \hat{\sigma}' \vee \check{\sigma} \in \mathcal{C}^{\text{fp}}(0)}} \mu_\beta(\hat{\sigma} \vee \check{\sigma}) c_\beta(\hat{\sigma} \vee \check{\sigma}, \hat{\sigma}' \vee \check{\sigma}) [g(\hat{\sigma}) - g(\hat{\sigma}')]^2, \end{aligned} \quad (4.10)$$

where $\hat{\mathcal{C}}^-(0)$, $\hat{\mathcal{C}}(0)^+$ denote the subsets of $\hat{\mathcal{C}}(0)$ where the free particle is at distance L_β , respectively, 2 from the proto-critical droplet, and the inequality comes from substituting

$$h(\hat{\sigma} \vee \check{\sigma}) = g(\hat{\sigma}), \quad \hat{\sigma} \in \hat{\mathcal{C}}(0), \check{\sigma} \in \check{\mathcal{C}}(0), \quad (4.11)$$

and afterwards replacing the double sum over $\check{\sigma}, \check{\sigma}' \in \check{\mathcal{C}}(0)$ by the single sum over $\check{\sigma} \in \check{\mathcal{C}}(0)$ because $c_\beta(\hat{\sigma} \vee \check{\sigma}, \hat{\sigma}' \vee \check{\sigma}') > 0$ only if either $\hat{\sigma} = \hat{\sigma}'$ or $\check{\sigma} = \check{\sigma}'$ (the dynamics updates one site at a time). Next, estimate

r.h.s.(4.10)

$$\leq \sum_{\check{\sigma} \in \check{\mathcal{C}}(0)} \frac{1}{Z_\beta^{(n_\beta)}} e^{-\beta H_\beta(\check{\sigma})} \min_{\substack{g: \hat{\mathcal{C}}(0) \rightarrow [0,1] \\ g|_{\hat{\mathcal{C}}^-(0)} \equiv 1, g|_{\hat{\mathcal{C}}^+(0)} \equiv 0}} \frac{1}{2} \sum_{\substack{\hat{\sigma}, \hat{\sigma}' \in \hat{\mathcal{C}}(0) \\ \hat{\sigma} \vee \check{\sigma}, \hat{\sigma}' \vee \check{\sigma} \in \mathcal{C}^{\text{fp}}(0)}} e^{-\beta H_\beta(\check{\sigma})} c_\beta(\hat{\sigma}, \hat{\sigma}') [g(\hat{\sigma}) - g(\hat{\sigma}')]^2, \quad (4.12)$$

where we used $H_\beta(\sigma) = H_\beta(\hat{\sigma}) + H_\beta(\check{\sigma})$ from (4.7) and write $c_\beta(\hat{\sigma}, \hat{\sigma}')$ to denote the transition rate associated with the Kawasaki dynamics restricted to $B_{L_\beta, L_\beta}(0)$, which clearly equals $c_\beta(\hat{\sigma} \vee \check{\sigma}, \hat{\sigma}' \vee \check{\sigma})$ for every $\check{\sigma} \in \check{\mathcal{C}}(0)$ such that $\hat{\sigma} \vee \check{\sigma}, \hat{\sigma}' \vee \check{\sigma} \in \mathcal{C}^{\text{fp}}(0)$ because there is no interaction between the particles inside and outside $B_{L_\beta, L_\beta}(0)$. The minimum in the r.h.s. of (4.12) can be estimated from above by

$$\sum_{\sigma \in \mathcal{P}(0)} \mathcal{V}_\beta(\sigma) \quad (4.13)$$

with $\mathcal{P}(0)$ the set of proto-critical droplets with lower-left corner at 0, and

$$\mathcal{V}_\beta(\sigma) = \min_{\substack{f: \mathbb{Z}^2 \rightarrow [0,1] \\ f|_{P_\sigma(0)} \equiv 1, f|_{[B_{L_\beta, L_\beta}(0)]^c} \equiv 0}} \frac{1}{2} \sum_{\substack{x, x' \in \mathbb{Z}^2 \\ x \sim x'}} [f(x) - f(x')]^2, \quad (4.14)$$

where $P_\sigma(0)$ is the support of the proto-critical droplet in σ , and $x \sim x'$ means that x and x' are neighboring sites. Indeed, (4.13) is obtained from the expression in (4.12) by dropping the restriction $\hat{\sigma} \vee \check{\sigma}, \hat{\sigma}' \vee \check{\sigma} \in \mathcal{C}^{\text{fp}}(0)$, substituting

$$g(P_\sigma(0) \cup \{x\}) = f(x), \quad \sigma \in \mathcal{P}(0), x \in B_{L_\beta, L_\beta}(0) \setminus P_\sigma(0), \quad (4.15)$$

and noting that $c_\beta(P_\sigma(0) \cup \{x\}, P_\sigma(0) \cup \{x'\}) = 1$ when $x \sim x'$ and zero otherwise. What (4.13) says is that

$$\mathcal{V}_\beta(\sigma) = \text{CAP}(P_\sigma(0), [B_{L_\beta, L_\beta}(0)]^c) \quad (4.16)$$

is the capacity of simple random walk between the proto-critical droplet $P_\sigma(0)$ in σ and the exterior of $B_{L_\beta, L_\beta}(0)$. Now, define

$$\check{Z}_\beta^{(n-K)}(0) = \sum_{\check{\sigma} \in \check{\mathcal{C}}(0)} e^{-\beta H_\beta(\check{\sigma})}. \quad (4.17)$$

Then we obtain via (4.13) that

$$\text{r.h.s.}(4.12) \leq e^{-\beta \Gamma^*} \frac{\check{Z}_\beta^{(n-K)}(0)}{Z_\beta^{(n_\beta)}} \sum_{\sigma \in \mathcal{P}(0)} \mathcal{V}_\beta(\sigma), \quad (4.18)$$

where $\Gamma^* = -U[(\ell_c - 1)^2 + \ell_c(\ell_c - 1) + 1]$ is the binding energy of the proto-critical droplet (compare with (1.33)).

4. Capacity estimate. For future reference we state the following estimate on capacities for simple random walk.

Lemma 4.3. *Let $U \subset \mathbb{Z}^2$ be any set such that $\{0\} \subset U \subset B_{k,k}(0)$, with $k \in \mathbb{N} \cup \{0\}$ independent of β . Let $V \subset \mathbb{Z}^2$ be any set such that $[B_{KL_\beta, KL_\beta}(0)]^c \subset V \subset [B_{L_\beta, L_\beta}(0)]^c$, with $K \in \mathbb{N}$ independent of β . Then*

$$\text{CAP}(\{0\}, [B_{KL_\beta, KL_\beta}(0)]^c) \leq \text{CAP}(U, V) \leq \text{CAP}(B_{k,k}(0), [B_{L_\beta, L_\beta}(0)]^c). \quad (4.19)$$

Moreover, via (1.29–1.30),

$$\text{CAP}(B_{k,k}(0), [B_{KL_\beta, KL_\beta}(0)]^c) = [1 + o(1)] \frac{2\pi}{\log(KL_\beta) - \log k} = [1 + o(1)] \frac{4\pi}{\beta\Delta}, \quad \beta \rightarrow \infty. \quad (4.20)$$

Proof. The inequalities in (4.19) follow from standard monotonicity properties of capacities. The asymptotic estimate in (4.20) for capacities of concentric boxes are standard (see e.g. Lawler [20], Section 2.3), and also follow by comparison to Brownian motion. \blacksquare

We can apply Lemma 4.3 to estimate $\mathcal{V}_\beta(\sigma)$ in (4.16), since the proto-critical droplet with lower-left corner in 0 fits inside the box $B_{2\ell_c, 2\ell_c}(0)$. This gives

$$\mathcal{V}_\beta(\sigma) = \frac{4\pi}{\beta\Delta} [1 + o(1)], \quad \forall \sigma \in \mathcal{P}(0), \beta \rightarrow \infty. \quad (4.21)$$

Moreover, from Bovier, den Hollander, and Nardi [7], Lemmas 3.4.2–3.4.3, we know that $N = |\mathcal{P}(0)|$, the number of shapes of the proto-critical droplet, equals $N = \frac{1}{3}\ell_c^2(\ell_c^2 - 1)$.

5. Equivalence of ensembles. According to Lemma B.1 in Appendix B, we have

$$\frac{\check{Z}_\beta^{(n_\beta - K)}(0)}{Z_\beta^{(n_\beta)}} = (\rho_\beta)^K \mu_\beta(\mathcal{S}) [1 + o(1)], \quad \beta \rightarrow \infty. \quad (4.22)$$

This is an “equivalence of ensembles” property relating the probabilities to find $n_\beta - K$, respectively, n_β particles inside $[B_{L_\beta, L_\beta}(0)]^c$ (recall (4.6)). Combining (4.2–4.3), (4.5), (4.8), (4.10), (4.12), (4.18) and (4.21–4.22), we get

$$\text{CAP}(\mathcal{S}, \mathcal{C}^+) \leq \gamma_1(\beta) + |\Lambda_\beta| \gamma_2(\beta) + N |\Lambda_\beta| \frac{4\pi}{\beta\Delta} e^{-\beta\Gamma} \mu_\beta(\mathcal{S}) [1 + o(1)], \quad \beta \rightarrow \infty, \quad (4.23)$$

where we use that $\Gamma^* + \Delta K = \Gamma$ defined in (1.33). This completes the proof of the upper bound, provided that the error terms $\gamma_1(\beta)$ and $\gamma_2(\beta)$ are negligible.

6. Second error term. To estimate the error term $\gamma_2(\beta)$, note that the configurations in $\tilde{\mathcal{C}}(0) \setminus \mathcal{C}^{\text{fp}}(0)$ are those for which inside $B_{L_\beta, L_\beta}(0)$ there is a proto-critical droplet whose lower-left corner is at 0, and a particle that is at the boundary and attached to some cluster outside $B_{L_\beta, L_\beta}(0)$. Recalling (4.5–4.9), we therefore have

$$\gamma_2(\beta) \leq \sum_{\sigma \in \tilde{\mathcal{C}}(0) \setminus \mathcal{C}^{\text{fp}}(0)} \sum_{\sigma' \in \tilde{\mathcal{C}}(0)} \mu_\beta(\sigma) c_\beta(\sigma, \sigma') [h(\sigma) - h(\sigma')]^2 \leq 6\mu_\beta(\tilde{\mathcal{C}}(0) \setminus \mathcal{C}^{\text{fp}}(0)), \quad (4.24)$$

where we use that $h: \tilde{\mathcal{C}}(0) \rightarrow [0, 1]$, $\mu_\beta(\sigma) c_\beta(\sigma, \sigma') = \mu_\beta(\sigma) \wedge \mu_\beta(\sigma')$, and there are 6 possible transitions from $\tilde{\mathcal{C}}(0) \setminus \mathcal{C}^{\text{fp}}(0)$ to $\tilde{\mathcal{C}}(0)$: 3 through a move by the particle at the boundary of $B_{L_\beta, L_\beta}(0)$ and 3 through a move by a particle in the cluster outside $B_{L_\beta, L_\beta}(0)$. Since

$$H_\beta(\sigma) \geq H_\beta(\hat{\sigma}) + H_\beta(\check{\sigma}) - U, \quad \sigma \in \tilde{\mathcal{C}}(0) \setminus \mathcal{C}^{\text{fp}}(0), \quad (4.25)$$

it follows from the same argument as in Steps 3 and 5 that

$$\mu_\beta(\tilde{\mathcal{C}}(0) \setminus \mathcal{C}^{\text{fp}}(0)) \leq N e^{-\beta\Gamma^*} (\rho_\beta)^{K+1} \mu_\beta(\mathcal{S}) e^{\beta U} 4(K-1) [1 + o(1)], \quad (4.26)$$

where $(\rho_\beta)^{K+1}$ comes from the fact that $n_\beta - (K+1)$ particles are outside $B_{L_{\beta-1}, L_{\beta-1}}(0)$ (once more use Lemma B.1 in Appendix B), $e^{\beta U}$ comes from the gap in (4.25), and $4(K-1)$ counts the maximal number of places at the boundary of $B_{L_\beta, L_\beta}(0)$ where the particle can interact with particles outside $B_{L_\beta, L_\beta}(0)$ due to the constraint that defines \mathcal{S} (recall Definition 1.3)(a)). Since $\rho_\beta e^{\beta U} = o(1)$ by (1.27), we therefore see that $\gamma_2(\beta)$ indeed is small compared to the main term of (4.23).

7. First error term. To estimate the error term $\gamma_1(\beta)$, we define the sets of pairs of configurations

$$\begin{aligned}\mathcal{I}_1 &= \{(\sigma, \eta) \in [\mathcal{X}_\beta^{(n_\beta)}]^2: \sigma \in \mathcal{S}, \eta \in \mathcal{S}^c \setminus \tilde{\mathcal{C}}\}, \\ \mathcal{I}_2 &= \{(\sigma, \eta) \in [\mathcal{X}_\beta^{(n_\beta)}]^2: \sigma \in \tilde{\mathcal{C}}, \eta \in \mathcal{S}^c \setminus \tilde{\mathcal{C}}\},\end{aligned}\tag{4.27}$$

and estimate

$$\gamma_1(\beta) \leq \frac{1}{2} \sum_{i=1}^2 \sum_{(\sigma, \eta) \in \mathcal{I}_i} \mu_\beta(\sigma) c_\beta(\sigma, \eta) = \frac{1}{2} \Sigma(\mathcal{I}_1) + \frac{1}{2} \Sigma(\mathcal{I}_2).\tag{4.28}$$

The sum $\Sigma(\mathcal{I}_1)$ can be written as

$$\Sigma(\mathcal{I}_1) = |\Lambda_\beta| \sum_{\sigma \in \mathcal{P}} \sum_{\eta \in \mathcal{S}^c \setminus \tilde{\mathcal{C}}} c_\beta(\eta, \sigma) \mathbf{1}\left\{|\text{supp}[\eta] \cap B_{L_\beta, L_\beta}(0)| = K\right\} \frac{1}{Z_\beta^{(n_\beta)}} e^{-\beta H_\beta(\eta)},\tag{4.29}$$

where we use that $\mu_\beta(\sigma) c_\beta(\sigma, \eta) = \mu_\beta(\eta) c_\beta(\eta, \sigma)$, $\sigma, \eta \in \mathcal{X}_\beta^{(n_\beta)}$, and $c_\beta(\eta, \sigma) = 0$, $\eta \in \mathcal{S}^c \setminus \tilde{\mathcal{C}}$, $\sigma \notin \mathcal{P}$ (recall Definition 1.3(b)). We have

$$H_\beta(\eta) \geq H_\beta(\hat{\eta}) + H_\beta(\check{\eta}) - kU, \quad \eta \in \mathcal{S}^c \setminus \tilde{\mathcal{C}},\tag{4.30}$$

where k counts the number of pairs of particles interacting across the boundary of $B_{L_\beta, L_\beta}(0)$. Moreover, since $\eta \notin \tilde{\mathcal{C}}$, we have

$$H_\beta(\hat{\eta}) \geq \Gamma^* + U.\tag{4.31}$$

Inserting (4.30–4.31) into (4.29), we obtain

$$\begin{aligned}\Sigma(\mathcal{I}_1) &\leq |\Lambda_\beta| e^{-\beta \Gamma^*} \mu_\beta(\mathcal{S}) [1 + o(1)] \sum_{k=0}^K (\rho_\beta)^{K+k} [4(K-1)]^k e^{\beta(k-1)U} \\ &= |\Lambda_\beta| e^{-\beta \Gamma} \mu_\beta(\mathcal{S}) [1 + o(1)] e^{-\beta U},\end{aligned}\tag{4.32}$$

where $(\rho_\beta)^{K+k}$ comes from the fact that $n_\beta - (K+k)$ particles are outside $B_{L_\beta-1, L_\beta-1}(0)$ (once more use Lemma B.1 in Appendix B), and the inequality again uses an argument similar as in Steps 3 and 5. Therefore $\Sigma(\mathcal{I}_1)$ is small compared to the main term of (4.23). The sum $\Sigma(\mathcal{I}_2)$ can be estimated as

$$\begin{aligned}\Sigma(\mathcal{I}_2) &= \sum_{\sigma \in \tilde{\mathcal{C}}} \sum_{\eta \in \mathcal{S}^c \setminus \tilde{\mathcal{C}}} \mu_\beta(\sigma) c_\beta(\sigma, \eta) \\ &= |\Lambda_\beta| \sum_{\sigma \in \tilde{\mathcal{C}}(0)} \mu_\beta(\sigma) \sum_{\eta \in \mathcal{S}^c \setminus \tilde{\mathcal{C}}(0)} c_\beta(\sigma, \eta) \\ &\leq |\Lambda_\beta| \mu_\beta(\tilde{\mathcal{C}}(0)) \left\{ e^{-\beta U} + (4L_\beta) \rho_\beta [1 + o(1)] \right\},\end{aligned}\tag{4.33}$$

where the first term comes from detaching a particle from the critical droplet and the second term from a extra particle entering $B_{L_\beta, L_\beta}(0)$. The term between braces is $o(1)$. Moreover, $\mu_\beta(\tilde{\mathcal{C}}(0)) = \mu_\beta(\mathcal{C}^{\text{fp}}(0)) + \mu_\beta(\tilde{\mathcal{C}}(0) \setminus \mathcal{C}^{\text{fp}}(0))$. The second term was estimated in (4.26), the first term can again be estimated as in Steps 3 and 5:

$$\mu_\beta(\mathcal{C}^{\text{fp}}(0)) = \sum_{\hat{\sigma} \in \hat{\mathcal{C}}(0)} \sum_{\substack{\check{\sigma} \in \check{\mathcal{C}}(0) \\ \hat{\sigma} \vee \check{\sigma} \in \mathcal{C}^{\text{fp}}(0)}} \mu_\beta(\hat{\sigma} \vee \check{\sigma}) = N e^{-\beta \Gamma^*} \frac{\check{Z}_\beta^{(n_\beta-K)}(0)}{Z_\beta^{(n_\beta)}} = N e^{-\beta \Gamma} \mu_\beta(\mathcal{S}) [1 + o(1)].\tag{4.34}$$

Therefore also $\Sigma(\mathcal{I}_2)$ is small compared to the main term of (4.23).

Lower bound: The proof of the lower bound follows the same line of argument as for Glauber dynamics in that it relies on the construction of a suitable unit flow. This flow will, however, be considerably more difficult. In particular, we will no longer be able to

get away with choosing a deterministic flow, and the full power of the Berman-Konsowa variational principle has to be brought to bear. The proof comes in 5 steps.

For future reference we state the following property of the harmonic function for simple random walk on \mathbb{Z}^2 .

Lemma 4.4. *Let g be the harmonic function of simple random walk on $B_{2L_\beta, 2L_\beta}(0)$ (which is equal to 1 on $\{0\}$ and 0 on $[B_{2L_\beta, 2L_\beta}(0)]^c$). Then there exists a constant $C < \infty$ such that*

$$\sum_e [g(z) - g(z + e)]_+ \leq C/L_\beta \quad \forall z \in [B_{L_\beta, L_\beta}(0)]^c. \quad (4.35)$$

Proof. See e.g. Lawler, Schramm and Werner [21], Lemma 5.1. The proof can be given via the estimates in Lawler [20], Section 1.7, or via a coupling argument. \blacksquare

1. Starting configurations. We start our flow on a subset of the configurations in \mathcal{C}^+ that is sufficiently large and sufficiently convenient. Let $\mathcal{C}_2^+ \subset \mathcal{C}^+$ denote the set of configurations having a proto-critical with lower-left corner at some site $x \in \Lambda_\beta$, a free particle at distance 2 from this proto-critical droplet, no other particles in the box $B_{2L_\beta, 2L_\beta}(x)$, and satisfying the constraints in \mathcal{S}_L , i.e., all other boxes of size $2L_\beta$ carry no more particles than there are in a proto-critical droplet. This is the same as \mathcal{C}^+ , except that the box around the proto-critical droplet has size $2L_\beta$ rather than L_β .

Let $K = \ell_c(\ell_c - 1) + 2$ be the volume of the critical droplet, and let $\mathcal{S}_2^{(n_\beta - K)}$ be the analogue of \mathcal{S} when the total number of particles is $n_\beta - K$ and the boxes in which we count particles have size $2L_\beta$ (compare with Definition 1.3). Similarly as in (3.17), our task is to derive a lower bound for $\text{CAP}(\mathcal{S}_L, (\mathcal{S}^c \setminus \tilde{\mathcal{C}}) \cup \mathcal{C}^+) = \text{CAP}((\mathcal{S}^c \setminus \tilde{\mathcal{C}}) \cup \mathcal{C}^+, \mathcal{S}_L) \geq \text{CAP}(\mathcal{C}_L, \mathcal{S}_L)$, where $\mathcal{C}_L \subset \mathcal{C}_2^+ \subset \mathcal{C}^+$ defined by

$$\mathcal{C}_L = \{\sigma \cup P_{(y)}(x, z) : \sigma \in \mathcal{S}_2^{(n_\beta - K)}, x, y \in \Lambda_\beta, (x, y, z) \perp \sigma\} \quad (4.36)$$

is the analog of (3.13), namely, the set of configurations obtained from $\mathcal{S}_2^{(n_\beta - K)}$ by adding a critical droplet somewhere in Λ_β (lower-left corner at x , protuberance at y , free particle at z) such that it does not interact with the particles in σ and has an empty box of size $2L_\beta$ around it. Note that the $n_\beta - K$ particles can block at most $n_\beta(2L_\beta)^2 = o(|\Lambda_\beta|)$ sites from being the center of an empty box of size $2L_\beta$, and so the critical particle can be added at $|\Lambda_\beta| - o(|\Lambda_\beta|)$ locations.

We partition \mathcal{C}_L into sets $\mathcal{C}_L(x)$, $x \in \Lambda_\beta$, according to the location of the proto-critical droplet. It suffices to consider the case where the critical droplet is added at $x = 0$, because the union over x trivially produces a factor $|\Lambda_\beta|$.

2. Overall strategy. Starting from a configuration in $\mathcal{C}_L(0)$, we will successively pick $K - L$ particles from the critical droplet (starting with the free particle at z at distance 2) and move them out of the box $B_{L_\beta, L_\beta}(0)$, placing them essentially uniformly in the annulus $B_{2L_\beta, 2L_\beta}(0) \setminus B_{L_\beta, L_\beta}(0)$. Once this has been achieved, the configuration is in \mathcal{S}_L . Each such move will produce an entropy of order L_β^2 , which will be enough to compensate for the loss of energy in tearing down the droplet (recall Fig. 4). The order in which the particles are removed follows the canonical order employed in the lower bound for Glauber dynamics (recall Fig. 6). As for Glauber, we will use Proposition 2.4 to estimate

$$\text{CAP}(\mathcal{C}_L, \mathcal{S}_L) \geq |\Lambda_\beta| \sum_{\sigma \in \mathcal{C}_L(0)} \sum_{\gamma: \gamma_0 = \sigma} \mathbb{P}^f(\gamma) \sum_{k=0}^{\tau(\gamma)} \left[\frac{f(\gamma_k, \gamma_{k+1})}{\mu_\beta(\gamma_k) c_\beta(\gamma_k, \gamma_{k+1})} \right]^{-1} \quad (4.37)$$

for a suitably constructed flow f and associated path measure \mathbb{P}^f , starting from some initial distribution on $\mathcal{C}_L(0)$ (which as for Glauber will be irrelevant), and $\tau(\gamma)$ the time at which the last of the $K - L$ particles exits the box $B_{L_\beta, L_\beta}(0)$.

The difference between Glauber and Kawasaki is that, while in Glauber the droplet can be torn down via single spin-flips, in Kawasaki after we have detached a particle from the droplet we need to move it out of the box $B_{L_\beta, L_\beta}(0)$, which takes a large number of steps. Thus, $\tau(\gamma)$ is the sum of $K - L$ stopping times, each except the first of which is a sum of two stopping times itself, one to detach the particle and one to move it out of the box $B_{L_\beta, L_\beta}(0)$. With each motion of a single particle we need to gain an entropy factor of order close to $1/\rho_\beta$. This will be done by constructing a flow that involves only the motion of this single particle, based on the harmonic function of the simple random walk in the box $B_{2L_\beta, 2L_\beta}(0)$ up to the boundary of the box $B_{L_\beta, L_\beta}(0)$. Outside $B_{L_\beta, L_\beta}(0)$ the flow becomes more complex: we modify it in such a way that a small fraction of the flow, of order $L_\beta^{-1+\epsilon}$ for some $\epsilon > 0$ small enough, is going into the direction of removing the next particle from the droplet. The reason for this choice is that we want to make sure that the flow becomes sufficiently small, of order $L_\beta^{-2+\epsilon}$, so that this can compensate for the fact that the Gibbs weight in the denominator of the lower bound in (2.20) is reduced by a factor $e^{-\beta U}$ when the protuberance is detached. The reason for the extra ϵ is that we want to make sure that, along most of the paths, the protuberance is detached before the first particle leaves the box $B_{2L_\beta, 2L_\beta}(0)$.

Once the protuberance detaches itself from the proto-critical, the first particle stops and the second particle moves in the same way as the first particle did when it moved away from the proto-critical droplet, and so on. This is repeated until no more than L particles remain in $B_{L_\beta, L_\beta}(0)$, by which time we have reached \mathcal{S}_L . As we will see, the only significant contribution to the lower bound comes from the motion of the first particle (as for Glauber), and this coincides with the upper bound established earlier. The details of the construction are to some extent arbitrary and there are many other choices imaginable.

3. First particle. We first construct the flow that moves the particle at distance 2 from the proto-critical droplet to the boundary of the box $B_{L_\beta, L_\beta}(0)$. This flow will consist of independent flows for each fixed shape and location of the critical droplet. This first part of the flow will be seen to produce the essential contribution to the lower bound.

We label the configurations in $\mathcal{C}_L(0)$ by σ , describing the shape of the critical droplet, as well as the configuration outside the box $B_{2L_\beta, 2L_\beta}(0)$, and we label the position of the free particle in σ by $z_1(\sigma)$.

Let g be the harmonic function for simple random walk with boundary conditions 0 on $[B_{2L_\beta, 2L_\beta}(0)]^c$ and 1 on the critical droplet. Then we choose our flow to be

$$f(\sigma(z), \sigma(z')) = \begin{cases} C_1 [g(z) - g(z + e)]_+, & \text{if } z' = z + e, \|e\| = 1, \\ 0, & \text{otherwise,} \end{cases} \quad (4.38)$$

where $\sigma(z)$ is the configuration obtained from σ by placing the first particle at site z . The constant C_1 is chosen to ensure that f defines a unit flow in the sense of Definition 2.3, i.e.,

$$\sum_{\sigma \in \mathcal{C}_L(0)} C_1 \sum_{z_1(\sigma), e} [g(z_1(\sigma)) - g(z_1(\sigma) + e)] = C_1 \sum_{\sigma \in \mathcal{C}_L(0)} \text{CAP}(P_\sigma(0), [B_{2L_\beta, 2L_\beta}(0)]^c) = 1, \quad (4.39)$$

where $P_\sigma(0)$ denotes the support of the proto-critical droplet in σ , and the capacity refers to the simple random walk.

Now, let $z^1(k)$ be the location of the first particle at time k , and

$$\tau^1 = \inf\{k \in \mathbb{N} : z^1(k) \in [B_{L_\beta, L_\beta}(0)]^c\} \quad (4.40)$$

be the first time when, under the Markov chain associated to the flow f , it exits $B_{L_\beta, L_\beta}(0)$. Let γ be a path of this Markov chain. Then, by (4.38–4.39), we have

$$\sum_{k=0}^{\tau^1} \frac{f(\gamma_k, \gamma_{k+1})}{\mu_\beta(\gamma_k) c_\beta(\gamma_k, \gamma_{k+1})} = \frac{C_1 [g(z^1(0)) - g(z^1(\tau^1))]}{\mu_\beta(\gamma_0)} \quad (4.41)$$

where the sum over the g 's is telescoping because only paths along which the g -function decreases carry positive probability, and $c_\beta(\gamma_k, \gamma_{k+1}) = 1$ for all $0 \leq k \leq \tau^1$ because the first particle is free. We have $g(z^1(0)) = 1$, while, by Lemma 4.4, there exists a $C < \infty$ such that

$$g(x) \leq C / \log L_\beta, \quad x \in [B_{L_\beta, L_\beta}(0)]^c. \quad (4.42)$$

Therefore

$$\sum_{k=0}^{\tau^1} \frac{f(\gamma_k, \gamma_{k+1})}{\mu_\beta(\gamma_k) c_\beta(\gamma_k, \gamma_{k+1})} = \frac{C_1}{\mu_\beta(\gamma_0)} [1 + o(1)]. \quad (4.43)$$

Next, by Lemma 4.3, we have

$$\text{CAP}(P_\sigma(0), [B_{2L_\beta, 2L_\beta}(0)]^c) = \frac{4\pi}{\beta\Delta} [1 + o(1)], \quad \sigma \in \mathcal{C}_L(0), \beta \rightarrow \infty, \quad (4.44)$$

(because $\{0\} \subset P_\sigma(0) \subset B_{2\ell_c, 2\ell_c}(0)$ for all $\sigma \in \mathcal{C}_L(0)$). Since $N = |\mathcal{C}_L(0)|$, it follows from (4.39) that

$$\frac{1}{C_1} = N \frac{4\pi}{\beta\Delta} [1 + o(1)], \quad (4.45)$$

and so (4.43) becomes

$$\left[\sum_{k=0}^{\tau^1} \frac{f(\gamma_k, \gamma_{k+1})}{\mu_\beta(\gamma_k) c_\beta(\gamma_k, \gamma_{k+1})} \right]^{-1} = \mu_\beta(\gamma_0) N \frac{4\pi}{\beta\Delta} [1 + o(1)]. \quad \beta \rightarrow \infty, \quad (4.46)$$

This is the contribution we want, because when we sum (4.46) over $\gamma_0 = \sigma \in \mathcal{C}_L(0)$ (recall (4.37)), we get a factor

$$\mu_\beta(\mathcal{C}_L(0)) = e^{-\beta\Gamma} \mu_\beta(\mathcal{S}) [1 + o(1)]. \quad (4.47)$$

To see why (4.47) is true, recall from (4.36) that $\mathcal{C}_L(0)$ is obtained from $\mathcal{S}_2^{(n_\beta - K)}$ by adding a critical droplet with lower-left corner at the origin that does not interact with the $n_\beta - K$ particles elsewhere in Λ_β . Hence

$$\mu_\beta(\mathcal{C}_L(0)) = e^{-\beta\Gamma^*} \frac{\tilde{Z}_\beta^{(n_\beta - K)}(0)}{Z_\beta^{(n_\beta)}}, \quad (4.48)$$

where $\tilde{Z}_\beta^{(n_\beta - K)}(0)$ is the analog of $\check{Z}_\beta^{(n_\beta - K)}(0)$ (defined in (4.17)) obtained by requiring that the $n_\beta - K$ particles are in $[R_{\ell_c, \ell_c}(0)]^c$ instead of $[B_{L_\beta, L_\beta}(0)]^c$. However, it will follow from the proofs of Lemmas B.1–B.2 in Appendix B that, just as in (4.22),

$$\frac{\tilde{Z}_\beta^{(n_\beta - K)}(0)}{Z_\beta^{(n_\beta)}} = (\rho_\beta)^K \mu_\beta(\mathcal{S}) [1 + o(1)], \quad \beta\tau \rightarrow \infty, \quad (4.49)$$

which yields (4.47) because $\Gamma = \Gamma^* + K\Delta$. For the remaining part of the construction of the flow it therefore suffices to ensure that the sum beyond τ^1 gives a smaller contribution.

4. Second particle. Once the first particle (i.e., the free particle) has left the box $B_{L_\beta, L_\beta}(0)$, we need to allow the second particle (i.e., the protuberance) to detach itself from the proto-critical droplet and to move out of $B_{L_\beta, L_\beta}(0)$ as well. The problem is that detaching the second particle reduces the Gibbs weight appearing in the denominator by

$e^{-U\beta}$, while the increments of the flow are reduced only to about $1/L_\beta$. Thus, we cannot immediately detach the second particle. Instead, we do this with probability $L_\beta^{-1+\epsilon}$ only.

The idea is that, once the first particle is outside $B_{L_\beta, L_\beta}(0)$, we *leak* some of the flow that drives the motion of the first particle into a flow that detaches the second particle. To do this, we have to first construct a *leaky flow* in $B_{2L_\beta, 2L_\beta}(0) \setminus B_{L_\beta, L_\beta}(0)$ for simple random walk. This goes as follows.

Let $p(z, z+e)$ denote the transition probabilities of simple random walk driven by the harmonic function g on $B_{2L_\beta, 2L_\beta}(0)$. Put

$$\tilde{p}(z, z+e) = \begin{cases} p(z, z+e), & \text{if } z \in B_{L_\beta, L_\beta}(0), \\ (1 - L_\beta^{-1+\epsilon})p(z, z+e), & \text{if } z \in B_{2L_\beta, 2L_\beta}(0) \setminus B_{L_\beta, L_\beta}(0). \end{cases} \quad (4.50)$$

Use the transition probabilities $\tilde{p}(z, z+e)$ to define a path measure \tilde{P} . This path measure describes simple random walk driven by g , but with a killing probability $L_\beta^{-1+\epsilon}$ inside the annulus $B_{2L_\beta, 2L_\beta}(0) \setminus B_{L_\beta, L_\beta}(0)$. Put

$$k(z, z+e) = \sum_{\gamma} \tilde{P}(\gamma) \mathbb{1}_{(z, z+e) \in \gamma}, \quad z \in B_{2L_\beta, 2L_\beta}(0). \quad (4.51)$$

This edge function satisfies the following equations:

- $k(z, z+e) = [g(z) - g(z+e)]_+$,
if $z \in B_{L_\beta, L_\beta}(0)$,
- $k(z, z+e) = 0$,
if $z \in B_{2L_\beta, 2L_\beta}(0) \setminus B_{L_\beta, L_\beta}(0)$ and $[g(z) - g(z+e)]_+ = 0$,
- $(1 - L_\beta^{-1+\epsilon}) \sum_e k(z+e, z) \mathbb{1}_{g(z+e) - g(z) > 0} = \sum_e k(z, z+e) \mathbb{1}_{g(z) - g(z+e) > 0}$
if $z \in B_{2L_\beta, 2L_\beta}(0) \setminus B_{L_\beta, L_\beta}(0)$.

$$(4.52)$$

Note that inside the annulus $B_{2L_\beta, 2L_\beta}(0) \setminus B_{L_\beta, L_\beta}(0)$ at each site the flow out is less than the flow in by a leaking factor $1 - L_\beta^{-1+\epsilon}$. We pick $\epsilon > 0$ so small that

$$e^{\beta U} \text{ is exponentially smaller in } \beta \text{ than } L_\beta^{2-\epsilon}, \quad (4.53)$$

(which is possible by (1.27) and (1.29–1.30)). The important fact for us is that this leaky flow is dominated by the harmonic flow associated with g , in particular, the flow in satisfies

$$\sum_e k(z+e, z) \leq \sum_e [g(z+e) - g(z)]_+ \quad \forall z \in B_{2L_\beta, 2L_\beta}(0), \quad (4.54)$$

(and the same applies for the flow out). This inequality holds because g satisfies the same equations as in (4.50–4.51) but without the leaking factor $1 - L_\beta^{-1+\epsilon}$.

Using this leaky flow, we can now construct a flow involving the first two particles, as follows:

- $f(\sigma(z_1, a), \sigma(z_1 + e, a)) = C_1 k(z_1, z_1 + e)$,
if $z_1 \in B_{2L_\beta, 2L_\beta}(0)$,
- $f(\sigma(z_1, a), \sigma(z_1, b)) = C_1 L_\beta^{-1+\epsilon} \sum_e k(z_1, z_1 + e)$,
if $z_1 \in B_{2L_\beta, 2L_\beta}(0) \setminus B_{L_\beta, L_\beta}(0)$,
- $f(\sigma(z_1, z_2), \sigma(z_1, z_2 + e)) = \left\{ C_1 L_\beta^{-1+\epsilon} \sum_e k(z_1, z_1 + e) \right\} [g(z_2) - g(z_2 + e)]_+$,
if $z_1 \in B_{2L_\beta, 2L_\beta}(0) \setminus B_{L_\beta, L_\beta}(0), z_2 \in B_{L_\beta, L_\beta}(0) \setminus P_\sigma(0)$.

$$(4.55)$$

Here, we write a and b for the locations of the second particle prior and after it detaches itself from the proto-critical droplet, and $\sigma(z_1, z_2)$ for the configuration obtained from σ by placing the first particle (that was at distance 2 from the proto-critical droplet) at site z_1 and the second particle (that was the protuberance) at site z_2 . The flow for other motions is zero, and the constant C_1 is the *same* as in (4.38–4.39)

We next define two further stopping times, namely,

$$\zeta^2 = \inf\{k \in \mathbb{N} : z^2(\gamma_k) = b\}, \quad (4.56)$$

i.e., the first time the second particle (the protuberance) detaches itself from the proto-critical droplet, and

$$\tau^2 = \inf\{k \in \mathbb{N} : z^2(\gamma_k) \in [B_{L_\beta, L_\beta}(0)]^c\}, \quad (4.57)$$

i.e., the first time the second particle exits the box $B_{L_\beta, L_\beta}(0)$. Note that, since we choose the leaking probability to be $L^{-1+\epsilon}$, the probability that ζ^2 is larger than the first time the first particle exits $B_{2L_\beta, 2L_\beta}(0)$ is of order $\exp[-L_\beta^\epsilon]$ and hence is negligible. We will disregard the contributions of such paths in the lower bound. Paths with this property will be called *good*.

We will next show that (4.41) also holds if we extend the sum along any path of positive probability up to ζ^2 . The reason for this lies in Lemma flow-lb.11. Let γ be a path that has a positive probability under the path measure \mathbb{P}^f associated with f stopped at τ^2 . We will assume that this path is good in the sense described above. To that end we decompose

$$\begin{aligned} & \sum_{k=0}^{\tau^2} \frac{f(\gamma_k, \gamma_{k+1})}{\mu_\beta(\gamma_k) c_\beta(\gamma_k, \gamma_{k+1})} \\ &= \sum_{k=0}^{\tau^1} \frac{f(\gamma_k, \gamma_{k+1})}{\mu_\beta(\gamma_k) c_\beta(\gamma_k, \gamma_{k+1})} + \sum_{k=\tau^1+1}^{\zeta^2-2} \frac{f(\gamma_k, \gamma_{k+1})}{\mu_\beta(\gamma_k) c_\beta(\gamma_k, \gamma_{k+1})} + \sum_{k=\zeta^2-1}^{\tau^2} \frac{f(\gamma_k, \gamma_{k+1})}{\mu_\beta(\gamma_k) c_\beta(\gamma_k, \gamma_{k+1})} \\ &= I + II + III. \end{aligned} \quad (4.58)$$

The term I was already estimated in (4.41–4.47). To estimate II , we use (4.42) and (4.54–4.55) to bound (compare with (4.41))

$$II \leq C_1 \frac{g(z^1(\zeta^2)) - g(z^1(\tau^1))}{\mu_\beta(\gamma_0)} \leq C_1 \frac{[C/\log L_\beta]}{\mu_\beta(\gamma_0)}, \quad (4.59)$$

which is negligible compared to I due to the factor $C/\log L_\beta$. It remains to estimate III . Note that

$$III = \frac{f(\gamma_{\zeta^2-1}, \gamma_{\zeta^2})}{\mu_\beta(\gamma_{\zeta^2-1}) c_\beta(\gamma_{\zeta^2-1}, \gamma_{\zeta^2})} + \sum_{k=\zeta^2}^{\tau^2} \frac{f(\gamma_k, \gamma_{k+1})}{\mu_\beta(\gamma_k) c_\beta(\gamma_k, \gamma_{k+1})}. \quad (4.60)$$

The first term corresponds to the move when the protuberance detaches itself from the proto-critical droplet. Its numerator is given by $f(\sigma(z_1, a), \sigma(z_1, b))$ (for some $z_1 \in [B_{L_\beta, L_\beta}(0)]^c$) which, by Lemma 4.4 and (4.54–4.55), is smaller than $C_1 L_\beta^{-1+\epsilon} C L_\beta^{-1} = C_1 C L_\beta^{-2+\epsilon}$. On the other hand, its denominator is given by

$$\mu(\gamma_{\zeta^2-1}) c_\beta(\gamma_{\zeta^2-1}, \gamma_{\zeta^2}) = \mu_\beta(\gamma_0) e^{-U\beta}. \quad (4.61)$$

The same holds for the denominators in all the other terms in III , while the numerators in these terms satisfy the bound

$$f(\gamma_k, \gamma_{k+1}) \leq C_1 C L_\beta^{-2+\epsilon} [g(z^2(\gamma_k)) - g(z^2(\gamma_{k+1}))]. \quad (4.62)$$

Adding up the various terms, we get that

$$III \leq \frac{C_1}{\mu_\beta(\gamma_0)} L_\beta^{-2+\epsilon} e^{\beta U} \left(1 + [g(z^2(\zeta^2)) - g(z^2(\tau^2))]\right) \leq \frac{2C_1}{\mu_\beta(\gamma_0)} L_\beta^{-2+\epsilon} e^{\beta U}. \quad (4.63)$$

The right-hand side is smaller than I by a factor $L_\beta^{-2+\epsilon}e^{\beta U}$, which, by (4.53), is exponentially small in β .

5. Remaining particles. The lesson from the previous steps is that we can construct a flow with the property that each time we remove a particle from the droplet we gain a factor $L_\beta^{-2+\epsilon}$, i.e., almost $e^{-\Delta\beta}$. (This entropy gain corresponds to the gain from the magnetic field in Glauber dynamics, or from the activity in Kawasaki dynamics on a finite open box.) We can continue our flow by tearing down the critical droplet in the same order as we did for Glauber dynamics. Each removal corresponds to a flow that is built in the same way as described in Step 4 for the second particle. There will be some minor modifications involving a negligible fraction of paths where a particle hits a particle that was moved out earlier, but this is of no consequence. As a result of the construction, the sums along the remainders of these paths will give only negligible contributions.

Thus, we have shown that the lower bound coincides, up to a factor $1 + o(1)$, with the upper bound and the lemma is proven. \blacksquare

4.2. Proof of Theorem 1.4(b). The same observation holds as in (3.34).

Proof. The proof of Theorem 1.4(b) follows along the same lines as that of Theorem 1.4(a). The main point is to prove that $\text{CAP}(\mathcal{D}_M, \mathcal{S}_L) = [1+o(1)]\text{CAP}(\mathcal{C}^+, \mathcal{S}_L)$. Since $\text{CAP}(\mathcal{S}_L, \mathcal{D}_M) \leq \text{CAP}(\mathcal{S}_L, \mathcal{C}^+)$, we need only prove a lower bound on $\text{CAP}(\mathcal{D}_M, \mathcal{S}_L)$. This is done in almost exactly the same way as for Glauber, by using the construction given there and substituting each Glauber move by a flow involving the motion of just two particles.

Note that, as long as $M = e^{o(\beta)}$, an $M \times M$ droplet can be added at $|\Lambda_\beta| - o(|\Lambda_\beta|)$ locations to a configuration $\sigma \in \mathcal{S}$ (compare with (4.36)). The only novelty is that we have to eventually remove the cloud of particles that is produced in the annulus $B_{2L_\beta, 2L_\beta}(0) \setminus B_{L_\beta, L_\beta}(0)$. This is done in much the same way as before. As long as only $e^{o(\beta)}$ particles have to be removed, potential collisions between particles can be ignored as they are sufficiently unlikely. \blacksquare

APPENDIX A. APPENDIX: SPARSENESS OF SUBCRITICAL DROPLETS

Recall Definition 1.1(a) and (3.11–3.12). In this section we prove (3.22).

Lemma A.1. $\lim_{\beta \rightarrow \infty} \frac{1}{\beta} \log \frac{\mu_\beta(\mathcal{S} \setminus \mathcal{W})}{\mu_\beta(\mathcal{S})} = -\infty$.

Proof. We will prove that $\lim_{\beta \rightarrow \infty} \frac{1}{\beta} \log \mu_\beta(\mathcal{S} \setminus \mathcal{W}) / \mu_\beta(\Xi) = -\infty$. Since $\Xi \in \mathcal{S}$, this will prove the claim.

Let $f(\beta)$ be the function satisfying (3.11). We begin by noting that

$$\mu_\beta(\mathcal{S} \setminus \mathcal{W}) \leq \mu_\beta(\mathcal{I}) \quad \text{with} \quad \mathcal{I} = \{\sigma \in \mathcal{S} : |\text{supp}[C_B(\sigma)]| > |\Lambda_\beta|/f(\beta)\}, \quad (\text{A.1})$$

because the bootstrap percolation map increases the number of (+1)-spins. Let $\mathcal{D}(k)$ denote the set of configurations whose support consists on k non-interacting subcritical rectangles. Put $C_1 = (\ell_c + 2)(\ell_c + 1)$. Since the union of a subcritical rectangle and its exterior boundary has at most C_1 sites, it follows that in \mathcal{I} there are at least $|\Lambda_\beta|/C_1 f(\beta)$ non-interacting rectangles. Thus, we have

$$\mu_\beta(\mathcal{I}) \leq \sum_{k=\frac{|\Lambda_\beta|}{C_1 f(\beta)}}^{K_{\max}} F(k) \quad \text{with} \quad F(k) = \frac{1}{Z_\beta} \sum_{\substack{\sigma \in \mathcal{X}_\beta: \\ \mathcal{C}(\sigma) \in \mathcal{D}(k)}} e^{-\beta H_\beta(\sigma)}, \quad (\text{A.2})$$

where $K_{\max} \leq |\Lambda_\beta|$.

Next, note that

$$F(k) \leq (2^{C_1})^k \frac{1}{Z_\beta} \sum_{\sigma \in \mathcal{D}(k)} e^{-\beta H_\beta(\sigma)}. \quad (\text{A.3})$$

Since the bootstrap percolation map is downhill, the energy of a subcritical rectangle is bounded below by $C_2 = 2J - h$ (recall Fig. 9), and the number of ways to place k rectangles in Λ_β is at most $\binom{|\Lambda_\beta|}{k}$, it follows that

$$F(k) \leq 2^{C_1 k} \binom{|\Lambda_\beta|}{k} \mu_\beta(\boxminus) e^{-C_2 \beta k} \leq 2^{C_1 k} (C_1 e f(\beta))^k \mu_\beta(\boxminus) e^{-C_2 \beta k} \leq \mu_\beta(\boxminus) \exp[-\frac{1}{2} C_2 \beta k], \quad (\text{A.4})$$

where the second inequality uses that $k! \geq k^k e^{-k}$, $k \in \mathbb{N}$, and the third inequality uses that $f(\beta) = e^{o(\beta)}$. We thus have

$$\sum_{k=\frac{|\Lambda_\beta|}{C_1 f(\beta)}}^{K_{\max}} F(k) \leq 2 \mu_\beta(\boxminus) f(\beta) \frac{|\Lambda_\beta|}{f(\beta)} \exp\left[-\frac{1}{2} \frac{C_2}{C_1} \beta \frac{|\Lambda_\beta|}{f(\beta)}\right], \quad (\text{A.5})$$

which is the desired estimate because $|\Lambda_\beta|/f(\beta)$ tends to infinity. \blacksquare

APPENDIX B. APPENDIX: EQUIVALENCE OF ENSEMBLES AND TYPICALITY OF HOLES

For $m \in \mathbb{N}$, let

$$\mathcal{S}^{(m)} = \{\sigma \in \mathcal{X}_\beta^{(m)} : |\text{supp}[\sigma] \cap B_{L_\beta, L_\beta}(x)| \leq \ell_c(\ell_c - 1) + 1 \ \forall x \in \Lambda_\beta\} \quad (\text{B.1})$$

and

$$\begin{aligned} \check{\mathcal{C}}^{(m)}(0) &= \{\sigma \mathbb{1}_{\in B_{L_\beta, L_\beta}(0)} : \sigma \in \mathcal{S}^{(m)}\}, \\ \check{Z}_\beta^{(m)}(0) &= \sum_{\sigma \in \check{\mathcal{C}}^{(m)}(0)} e^{-\beta H(\sigma)}. \end{aligned} \quad (\text{B.2})$$

The latter is the partition sum restricted to $B_{L_\beta, L_\beta}(0)$ when it carries m particles. In Appendix B.1 we prove a lemma about ratios of partition sums that was used in (4.22), (4.26), (4.32) and (4.49). In Appendix B.2 we prove that $\lim_{\beta \rightarrow \infty} \mu_\beta(\check{\mathcal{S}}(0))/\mu_\beta(\mathcal{S}) = 1$, which is needed in the proof of this lemma.

B.1. Equivalence of ensembles. Recall (1.22), (4.6) and (4.17).

Lemma B.1. $\check{Z}_\beta^{(n_\beta - s)}(0)/Z_\beta^{(n_\beta)} = (\rho_\beta)^s \mu_\beta(\mathcal{S}) [1 + o(1)]$ as $\beta \rightarrow \infty$ for all $s \in \mathbb{N}$.

Proof. The proof proceeds via upper and lower bounds.

Upper bound: Let

$$\check{\mathcal{S}}(0) = \{\sigma \in \mathcal{S} : \text{supp}[\sigma] \cap B_{L_\beta, L_\beta}(0) = \emptyset\}. \quad (\text{B.3})$$

Write

$$\mu_\beta(\check{\mathcal{S}}(0)) = \frac{1}{Z_\beta^{(n_\beta)}} \sum_{\check{\sigma} \in \check{\mathcal{C}}(0)} \sum_{\substack{\zeta \subset [B_{L_\beta, L_\beta}(0)]^c \setminus \text{supp}[\check{\sigma}] \\ |\zeta| = s}} \binom{n_\beta}{s}^{-1} \mathbb{1}_{\{\check{\sigma} \vee \zeta \in \check{\mathcal{S}}(0)\}} e^{-\beta H_\beta(\check{\sigma} \vee \zeta)}. \quad (\text{B.4})$$

This relation simply says that n_β particles can be placed outside $B_{L_\beta, L_\beta}(0)$ by first placing $n_\beta - s$ particles and then placing another s particles. Because the interaction is attractive, we have

$$H_\beta(\check{\sigma} \vee \zeta) \leq H_\beta(\check{\sigma}) + H_\beta(\zeta) \text{ and } H_\beta(\zeta) \leq 0, \quad \forall \check{\sigma}, \zeta. \quad (\text{B.5})$$

Consequently,

$$\mu_\beta(\check{\mathcal{S}}(0)) \geq \binom{n_\beta}{s}^{-1} \frac{1}{Z_\beta^{(n_\beta)}} \sum_{\check{\sigma} \in \check{\mathcal{C}}(0)} e^{-\beta H_\beta(\check{\sigma})} \sum_{\substack{\zeta \subset [B_{L_\beta, L_\beta}(0)]^c \setminus \text{supp}[\check{\sigma}] \\ |\zeta|=s}} \mathbb{1}_{\{\check{\sigma} \vee \zeta \in \check{\mathcal{S}}(0)\}}. \quad (\text{B.6})$$

We next estimate the second sum, uniformly in $\check{\sigma}$. When we add the s particles, we must make sure not to violate the requirement that all boxes $B_{L_\beta, L_\beta}(x)$, $x \in \Lambda_\beta$, carry not more than K particles (note that $\check{\mathcal{S}}(0) \subset \mathcal{S}$ and recall Definition 1.3(a)). Partition $\Lambda_\beta \setminus B_{L_\beta, L_\beta}(0)$ into boxes of size L_β . The total number of boxes containing K particles is at most n_β/K . Hence, the total number of sites where we cannot place a particle is at most $(n_\beta/K)(3L_\beta)^2$. Therefore

$$\sum_{\substack{\zeta \subset [B_{L_\beta, L_\beta}(0)]^c \setminus \{\check{\sigma}\} \\ |\zeta|=s}} \mathbb{1}_{\{\check{\sigma} \vee \zeta \in \check{\mathcal{S}}(0)\}} \geq \binom{|\Lambda_\beta \setminus B_{L_\beta, L_\beta}(0)| - n_\beta - (n_\beta/K)(3L_\beta)^2}{s}, \quad \forall \check{\sigma}. \quad (\text{B.7})$$

But $n_\beta L_\beta^2 = o(n_\beta/\rho_\beta) = o(|\Lambda_\beta|)$ and $L_\beta^2 = o(1/\rho_\beta) = o(|\Lambda_\beta|)$ by (1.22) and (1.29–1.30), and so the right-hand side of (B.7) equals $[1 + o(1)] |\Lambda_\beta|^s / s!$ as $\beta \rightarrow \infty$. Since the binomial in (B.6) equals $[1 + o(1)] (n_\beta)^s / s!$ with $n_\beta = \lceil \rho_\beta |\Lambda_\beta| \rceil$, we end up with (recall (4.17))

$$\mu_\beta(\check{\mathcal{S}}(0)) \geq \frac{\check{Z}_\beta^{(n_\beta-s)}(0)}{Z_\beta^{(n_\beta)}} (\rho_\beta)^{-s} [1 + o(1)], \quad (\text{B.8})$$

or

$$\frac{\check{Z}_\beta^{(n_\beta-s)}(0)}{Z_\beta^{(n_\beta)}} \leq (\rho_\beta)^s \mu_\beta(\check{\mathcal{S}}(0)) [1 + o(1)]. \quad (\text{B.9})$$

Since $\check{\mathcal{S}}(0) \subset \mathcal{S}$, this gives the desired upper bound.

Lower bound: Return to (B.4). Among the s particles that are added to $[B_{L_\beta, L_\beta}(0)]^c$, let s_1 count the number that interact with the $n_\beta - s$ particles already present and s_2 the number that interact among themselves, where $s_1 + s_2 \leq s$. We can then estimate

$$\begin{aligned} & \mu_\beta(\check{\mathcal{S}}(0)) \\ & \leq \frac{1}{Z_\beta^{(n_\beta)}} \sum_{\check{\sigma} \in \check{\mathcal{C}}(0)} \binom{n_\beta}{s}^{-1} e^{-\beta H_\beta(\check{\sigma})} \sum_{\substack{s_1, s_2 \\ 0 \leq s_1 + s_2 \leq s}} \left(\frac{s!}{s_1! s_2!} \right)^{-1} \\ & \quad \times \sum_{\substack{\zeta \subset [B_{L_\beta, L_\beta}(0)]^c \setminus \text{supp}[\check{\sigma}] \\ |\zeta|=s}} e^{-\beta H(\zeta)} \mathbb{1}_{\{|\zeta \cap \partial \check{\sigma}| = s_1\}} \mathbb{1}_{\{s_2 \text{ interacting particles in } \zeta\}} \mathbb{1}_{\{\check{\sigma} \vee \zeta \in \check{\mathcal{S}}(0)\}} \\ & \leq [1 + o(1)] \frac{\check{Z}_\beta^{(n_\beta-s)}(0)}{Z_\beta^{(n_\beta)}} (\rho_\beta)^{-s} \\ & \quad + \frac{1}{Z_\beta^{(n_\beta)}} \sum_{\check{\sigma} \in \check{\mathcal{C}}(0)} \binom{n_\beta}{s}^{-1} e^{-\beta H_\beta(\check{\sigma})} \sum_{\substack{s_1, s_2 \\ 1 \leq s_1 + s_2 \leq s}} \\ & \quad \times \sum_{\substack{\zeta \subset [B_{L_\beta, L_\beta}(0)]^c \setminus \text{supp}[\check{\sigma}] \\ |\zeta|=s}} e^{-\beta H(\zeta)} \mathbb{1}_{\{|\zeta \cap \partial \check{\sigma}| = s_1\}} \mathbb{1}_{\{s_2 \text{ interacting particles in } \zeta\}} \mathbb{1}_{\{\check{\sigma} \vee \zeta \in \check{\mathcal{S}}(0)\}}, \end{aligned} \quad (\text{B.10})$$

where in the second inequality we estimate the term with $s_1 = s_2 = 0$ by using the result for the upper bound. We will show that the other terms are exponentially small.

For fixed $\check{\sigma}$, we may estimate the last sum in (B.10) as

$$\begin{aligned} & \sum_{\substack{\zeta \subset [B_{L_\beta, L_\beta(0)}]^c \setminus \text{supp}[\check{\sigma}] \\ |\zeta|=s}} e^{-\beta H(\zeta)} \mathbb{1}_{\{|\zeta \cap \partial \check{\sigma}|=s_1\}} \mathbb{1}_{\{s_2 \text{ interacting particles in } \zeta\}} \mathbb{1}_{\{\check{\sigma} \vee \zeta \in \check{\mathcal{S}}(0)\}} \\ & \leq |\Lambda_\beta|^{s-s_1-s_2} (4n_\beta)^{s_1} \sum_{\sigma \in \mathcal{S}^{(s_2)}} e^{-\beta H(\sigma)} \mathbb{1}_{\{s_2 \text{ interacting particles in } \sigma\}}. \end{aligned} \quad (\text{B.11})$$

Indeed, $|\Lambda_\beta|^{s-s_1-s_2}$ bounds the number of ways to place $s-s_1-s_2$ non-interacting particles, and $(4n_\beta)^{s_1}$ the number of ways to place s_1 particles that are interacting with the $n_\beta-s$ particles already present. Next, we write

$$\begin{aligned} & \sum_{\sigma \in \mathcal{S}^{(s_2)}} e^{-\beta H(\sigma)} \mathbb{1}_{\{s_2 \text{ interacting particles in } \sigma\}} \\ & = \sum_{m=1}^{s_2} \sum_{j=1}^m \sum_{\substack{2 \leq k_1, \dots, k_j \leq K \\ \sum_{i=1}^j k_i = m}} \sum_{\substack{C = \cup_{i=1}^j C_i \\ |C_i| = k_i \forall i}} e^{-\beta \sum_{i=1}^j H(C_i)}, \end{aligned} \quad (\text{B.12})$$

which is a cluster expansion of the partition function (with non-interacting clusters C_i , all of which have size $\leq K = \ell_c(\ell_c + 1) + 1$). By a standard isoperimetric inequality we have $H(C_i) \geq H_{k_i}$, with the latter denoting the energy of a droplet of $k_i = |C_i|$ particles that is closest to a square or quasi-square. Hence

$$\begin{aligned} & |\Lambda_\beta|^{-s_2} \sum_{\sigma \in \mathcal{S}^{(s_2)}} e^{-\beta H(\sigma)} \mathbb{1}_{\{s_2 \text{ interacting particles in } \sigma\}} \\ & \leq |\Lambda_\beta|^{-s_2} \sum_{m=1}^{s_2} \sum_{j=1}^m \sum_{\substack{2 \leq k_1, \dots, k_j \leq K \\ \sum_{i=1}^j k_i = s_2}} e^{-\beta \sum_{i=1}^j H_{k_i}} \left(\sum_{\substack{C = \cup_{i=1}^j C_i \\ |C_i| = k_i \forall i}} 1 \right) \\ & \leq C |\Lambda_\beta|^{-s_2} \sum_{m=1}^{s_2} \sum_{j=1}^m \sum_{\substack{2 \leq k_1, \dots, k_j \leq K \\ \sum_{i=1}^j k_i = s_2}} e^{-\beta \sum_{i=1}^j H_{k_i}} |\Lambda_\beta|^j \\ & \leq C \sum_{m=1}^{s_2} \sum_{j=1}^m \sum_{\substack{2 \leq k_1, \dots, k_j \leq K \\ \sum_{i=1}^j k_i = s_2}} e^{-\beta \sum_{i=1}^j [H_{k_i} + (k_i-1)\beta^{-1} \log |\Lambda_\beta|]} \\ & \leq \sum_{m=1}^{s_2} \sum_{j=1}^m \sum_{\substack{2 \leq k_1, \dots, k_j \leq K \\ \sum_{i=1}^j k_i = s_2}} e^{-\beta \sum_{i=1}^j [H_{k_i} + (k_i-1)\Delta]}, \end{aligned} \quad (\text{B.13})$$

where in the last inequality we insert the bound $\beta^{-1} \log |\Lambda_\beta| \geq \Delta$, which is a immediate from (1.22) and (1.35).

Now, $H_{k_i} + k_i \Delta$ is the *grand-canonical* energy of a square or quasi-square with k_i particles. It was shown in the proof of Proposition 2.4.2 in Bovier, den Hollander and Nardi [7] that this energy is $\geq U\sqrt{k_i}$ for $1 \leq k_i \leq 4K$, i.e., for a droplet twice the size of the proto-critical droplet. Since $2U > \Delta$, we therefore have that $H_{k_i} + (k_i-1)\Delta > 0$ when $k_i \geq 4$. Since $\Delta > U$, $H_2 = -U$ and $H_3 = -2U$, we have that also the terms with $k_i = 2, 3$ are > 0 . Consequently, there exist $\epsilon > 0$ and a constant C that is independent of β such that

$$|\Lambda_\beta|^{-s_2} \sum_{\sigma \in \mathcal{S}^{(s_2)}} e^{-\beta H(\sigma)} \mathbb{1}_{\{s_2 \text{ interacting particles in } \sigma\}} e^{-\beta H(\sigma)} \leq C e^{-\beta \epsilon}. \quad (\text{B.14})$$

Combining (B.10–B.11) and (B.14), we see that the correction term in (B.10) is

$$\begin{aligned} \mu_\beta(\check{\mathcal{S}}(0)) - [1 + o(1)] \frac{\check{Z}_\beta^{(n_\beta-s)}(0)}{Z_\beta^{(n_\beta)}} (\rho_\beta)^{-s} \\ \leq C [1 + o(1)] \frac{\check{Z}_\beta^{(n_\beta-s)}(0)}{Z_\beta^{(n_\beta)}} (\rho_\beta)^{-s} \sum_{\substack{s_1, s_2 \\ 1 \leq s_1 + s_2 \leq s}} (e^{U\beta} \rho_\beta)^{s_1} e^{-\beta\epsilon}. \end{aligned} \quad (\text{B.15})$$

Since $\Delta > U$, we have $e^{U\beta} \rho_\beta \leq 1$ and so the sum is $o(1)$. Hence

$$\frac{\check{Z}_\beta^{(n_\beta-s)}(0)}{Z_\beta^{(n_\beta)}} \geq (\rho_\beta)^s \mu_\beta(\check{\mathcal{S}}(0)) [1 + o(1)]. \quad (\text{B.16})$$

The claim now follows by using Lemma B.2 below. \blacksquare

B.2. Typicality of holes.

Lemma B.2. $\lim_{\beta \rightarrow \infty} \mu_\beta(\check{\mathcal{S}}(0)) / \mu_\beta(\mathcal{S}) = 1$.

Proof. Since $\check{\mathcal{S}}(0) \subset \mathcal{S}$, we have $\mu_\beta(\check{\mathcal{S}}(0)) \leq \mu_\beta(\mathcal{S})$. It therefore remains to prove the lower bound. Write

$$\begin{aligned} \mu_\beta(\mathcal{S}) &= \mu_\beta(\check{\mathcal{S}}(0)) \\ &\quad + \sum_{m=1}^K \sum_{\eta \in \mathcal{X}_\beta^{(m)}} \sum_{\substack{\zeta \in \mathcal{X}_\beta^{(n_\beta-m)} \\ \eta \vee \zeta \in \mathcal{S}}} \frac{e^{-\beta H(\eta \vee \zeta)}}{Z_\beta^{(n_\beta)}} \mathbb{1}_{\{\text{supp}[\eta] \subset B_{L_\beta, L_\beta}(0)\}} \mathbb{1}_{\{\text{supp}[\zeta] \subset [B_{L_\beta, L_\beta}(0)]^c\}} \\ &\leq \mu_\beta(\check{\mathcal{S}}(0)) + \gamma_1(\beta) + \gamma_2(\beta), \end{aligned} \quad (\text{B.17})$$

where

$$\gamma_1(\beta) = \sum_{m=1}^K \sum_{\eta \in \mathcal{X}_\beta^{(m)}} \sum_{\substack{\zeta \in \mathcal{X}_\beta^{(n_\beta-m)} \\ \eta \vee \zeta \in \mathcal{S}}} \frac{e^{-\beta [H(\eta) + H(\zeta)]}}{Z_\beta^{(n_\beta)}} \mathbb{1}_{\{\text{supp}[\eta] \subset B_{L_\beta, L_\beta}(0)\}} \mathbb{1}_{\{\text{supp}[\zeta] \subset [B_{L_\beta, L_\beta}(0)]^c\}} \quad (\text{B.18})$$

and $\gamma_2(\beta)$ is a term that arises from particles interacting across the boundary of $B_{L_\beta, L_\beta}(0)$. We will show that both $\gamma_1(\beta)$ and $\gamma_2(\beta)$ are negligible.

Estimate, with the help of (B.9) (and recalling (B.1–B.2)),

$$\begin{aligned} \gamma_1(\beta) &\leq \sum_{m=1}^K \frac{\check{Z}_\beta^{(n_\beta-m)}}{Z_\beta^{(n_\beta)}} \sum_{\eta \in \mathcal{S}^{(m)}} e^{-\beta H(\eta)} \mathbb{1}_{\{\text{supp}[\eta] \subset B_{L_\beta, L_\beta}(0)\}} \\ &= [1 + o(1)] \mu_\beta(\check{\mathcal{S}}(0)) \sum_{m=1}^K (\rho_\beta)^m \sum_{\eta \in \mathcal{S}^{(m)}} e^{-\beta H(\eta)} \mathbb{1}_{\{\text{supp}[\eta] \subset B_{L_\beta, L_\beta}(0)\}} \\ &= [1 + o(1)] \mu_\beta(\check{\mathcal{S}}(0)) \sum_{m=1}^K (\rho_\beta)^m \sum_{\substack{j=1 \\ \sum_{i=1}^j k_i = m}}^m \sum_{\substack{2 \leq k_1, \dots, k_j \leq K \\ |C_i| = k_i \forall i}} \sum_{C = \cup_{i=1}^j C_i} e^{-\beta \sum_{i=1}^j H(C_i)}, \end{aligned} \quad (\text{B.19})$$

where the last equality is a cluster expansion as in (B.12). Using once more the isoperimetric inequality, we get (recall (1.29))

$$\begin{aligned}
\gamma_1(\beta) &\leq [1 + o(1)] \mu_\beta(\check{\mathcal{S}}(0)) \sum_{m=1}^K (\rho_\beta)^m \sum_{j=1}^m \sum_{\substack{2 \leq k_1, \dots, k_j \leq K \\ \sum_{i=1}^j k_i = m}} e^{-\beta \sum_{i=1}^j H(k_i)} \left(\sum_{\substack{C = \cup_{i=1}^j C_i \\ |C_i| = k_i \forall i}} 1 \right) \\
&\leq C \mu_\beta(\check{\mathcal{S}}(0)) \sum_{m=1}^K (\rho_\beta)^m \sum_{j=1}^m (L_\beta^2)^j \sum_{\substack{2 \leq k_1, \dots, k_j \leq K \\ \sum_{i=1}^j k_i = m}} e^{-\beta \sum_{i=1}^j H_{k_i}} \\
&= C \mu_\beta(\check{\mathcal{S}}(0)) \sum_{m=1}^K \sum_{j=1}^m \sum_{\substack{2 \leq k_1, \dots, k_j \leq K \\ \sum_{i=1}^j k_i = m}} e^{-\beta \sum_{i=1}^j [H_{k_i} + k_i \Delta - (\Delta - \delta_\beta)]} \\
&\leq C' \mu_\beta(\check{\mathcal{S}}(0)) e^{-\beta \epsilon}
\end{aligned} \tag{B.20}$$

for some $\epsilon > 0$ and constants $C, C' < \infty$ that are independent of β .

Estimate, with the help of (B.9),

$$\begin{aligned}
\gamma_2(\beta) &\leq \sum_{m=1}^K \sum_{\eta \in \mathcal{S}^{(m)}} e^{-\beta H(\eta)} \sum_{k=1}^m e^{\beta k U} \mathbb{1}_{\{\text{supp}[\eta] \subset B_{L_\beta, L_\beta}(0)\}} \frac{\check{Z}_\beta^{(n_\beta - (m+k))}}{Z_\beta^{(n_\beta)}} \\
&\leq \sum_{m=1}^K \sum_{\eta \in \mathcal{S}^{(m)}} e^{-\beta H(\eta)} \sum_{k=1}^m e^{\beta k U} \mathbb{1}_{\{\text{supp}[\eta] \subset B_{L_\beta, L_\beta}(0)\}} (\rho_\beta)^{m+k} \mu_\beta(\check{\mathcal{S}}(0)) [1 + o(1)] \\
&\leq [1 + o(1)] \mu_\beta(\check{\mathcal{S}}(0)) \sum_{m=1}^K (\rho_\beta)^m \sum_{\eta \in \mathcal{S}^{(m)}} e^{-\beta H(\eta)} \sum_{k=1}^m e^{-\beta k(\Delta - U)} \mathbb{1}_{\{\text{supp}[\eta] \subset B_{L_\beta, L_\beta}(0)\}},
\end{aligned} \tag{B.21}$$

and we can proceed as (B.19–B.20) to show that this term is negligible. \blacksquare

B.3. Atypicality of critical droplets. The following lemma was used in Section 4.1.1.

Lemma B.3. $\lim_{\beta \rightarrow \infty} \mu_\beta(\tilde{\mathcal{C}} \setminus \mathcal{C}^+) / \mu_\beta(\mathcal{S}) = 0$.

Proof. Similarly as in (B.17), we first write

$$\begin{aligned}
\mu_\beta(\tilde{\mathcal{C}} \setminus \mathcal{C}^+) &\leq \mu_\beta(\tilde{\mathcal{C}}) \\
&= |\Lambda_\beta| \gamma(\beta) + |\Lambda_\beta| \sum_{\eta \in \mathcal{X}_\beta^{(K)}} \sum_{\substack{\zeta \in \mathcal{X}_\beta^{(n_\beta - K)} \\ \eta \vee \zeta \in \tilde{\mathcal{C}}}} \frac{e^{-\beta [H(\eta) + H(\zeta)]}}{Z_\beta^{(n_\beta)}} \mathbb{1}_{\{\text{supp}[\eta] \subset B_{L_\beta, L_\beta}(0)\}} \mathbb{1}_{\{\text{supp}[\zeta] \subset [B_{L_\beta, L_\beta}(0)]^c\}}.
\end{aligned} \tag{B.22}$$

with $\gamma(\beta)$ a negligible error term that arises from particles interacting across the boundary of $B_{L_\beta, L_\beta}(0)$. We then proceed as in (B.18–B.20), obtaining $(\Gamma = \Gamma^* + K\Delta)$

$$\begin{aligned}
\text{r.h.s. (B.22)} &\leq N |\Lambda_\beta| e^{-\beta \Gamma^*} (\rho_\beta)^K \mu_\beta(\check{\mathcal{S}}(0)) [1 + o(1)] \\
&= N |\Lambda_\beta| e^{-\beta \Gamma} \mu_\beta(\mathcal{S}) [1 + o(1)], \quad \beta \rightarrow \infty,
\end{aligned} \tag{B.23}$$

which is $o(\mu_\beta(\mathcal{S}))$ by (1.35). \blacksquare

APPENDIX C. APPENDIX: TYPICALITY OF STARTING CONFIGURATIONS

In Sections C.1–C.2 we prove the claims made in the remarks below (1.9), respectively, (1.32).

C.1. Glauber.

Proof. Split

$$\mathcal{S} = \mathcal{S}_L \cup (\mathcal{S} \setminus \mathcal{S}_L) = \mathcal{S}_L \cup \mathcal{U}_{>L}, \quad (\text{C.1})$$

where $\mathcal{U}_{>L} \subset \mathcal{S}$ are those configurations σ for which $C_B(\sigma)$ has at least one rectangle that is larger than $Q_L(0)$. We have

$$C_B(\sigma) = \bigcup_{x \in X(\sigma)} R_{\ell_1(x), \ell_2(x)}(x), \quad (\text{C.2})$$

where $X(\sigma)$ is the set of lower-left corners of the rectangles in $C_B(\sigma)$, which in turn can be split as

$$X(\sigma) = X^{>L}(\sigma) \cup X^{\leq L}(\sigma), \quad (\text{C.3})$$

where $X^{>L}(\sigma)$ labels the rectangles that are larger than $Q_L(0)$ and $X^{\leq L}(\sigma)$ labels the rest. Let $\sigma|_A$ denote the restriction of σ to the set $A \subset \mathbb{Z}^2$. Then, for any $x \in X(\sigma)$, we have

$$H(\sigma) = H(\sigma|_{R_{\ell_1(x), \ell_2(x)}(x)}) + H(\sigma|_{R_{\ell_1(x), \ell_2(x)}^c(x)}), \quad (\text{C.4})$$

because the rectangles in $C_B(\sigma)$ are non-interacting. Since for $\sigma \in \mathcal{U}_{>L}$ there is at least one rectangle with lower-left corner in $X^{>L}(\sigma)$, we have

$$\begin{aligned} \mu_\beta(\mathcal{U}_{>L}) &\leq \sum_{x \in \Lambda_\beta} \sum_{\sigma \in \mathcal{S}} \mathbb{1}_{\{x \in X^{>L}(\sigma)\}} \mu_\beta(\sigma) \\ &= \sum_{x \in \Lambda_\beta} \sum_{\sigma \in \mathcal{S}} \mathbb{1}_{\{x \in X^{>L}(\sigma)\}} \frac{1}{Z_\beta} \exp \left\{ -\beta \left[H(\sigma|_{R_{\ell_1(x), \ell_2(x)}(x)}) + H(\sigma|_{R_{\ell_1(x), \ell_2(x)}^c(x)}) \right] \right\} \\ &\leq e^{-\beta \Gamma_{L+1}} \sum_{x \in \Lambda_\beta} \sum_{\sigma \in \mathcal{S}} \mathbb{1}_{\{x \in X^{>L}(\sigma)\}} \frac{1}{Z_\beta} e^{-\beta H(\sigma|_{R_{\ell_1(x), \ell_2(x)}^c(x)})}, \end{aligned} \quad (\text{C.5})$$

where Γ_{L+1} is the energy of $Q_{L+1}(0)$. In the last step we use the fact that the bootstrap map is downhill and that the energy of $Q_L(0)$ is increasing with L . Since the energy of a subcritical rectangle is non-negative, we get

$$\mu_\beta(\mathcal{U}_{>L}) \leq N_{L+1} e^{-\beta \Gamma_{L+1}} |\Lambda_\beta| \mu_\beta(\mathcal{S}) \quad (\text{C.6})$$

with N_{L+1} counting the number of configurations with support in $Q_{L+1}(0)$.

On the other hand, by considering only those configurations in $\mathcal{U}_{>L}$ that have a $Q_{L+1}(0)$ droplet, we get

$$\mu_\beta(\mathcal{U}_{>L}) \geq N_{L+1} e^{-\beta \Gamma_{L+1}} |\Lambda_\beta| \mu_\beta^{[Q_{L+1}(0)]^c}(\mathcal{S}), \quad (\text{C.7})$$

where the last factor is the Gibbs weight of the configurations in \mathcal{S} with support outside $[Q_{L+1}(0)]^c$. It is easy to show that $\mu_\beta^{[Q_{L+1}(0)]^c}(\mathcal{S}) = \mu_\beta(\mathcal{S})[1 + o(1)]$ as $\beta \rightarrow \infty$ and so

$$\mu_\beta(\mathcal{U}_{>L}) \geq N_{L+1} e^{-\beta \Gamma_{L+1}} |\Lambda_\beta| \mu_\beta(\mathcal{S}) [1 + o(1)], \quad \beta \rightarrow \infty. \quad (\text{C.8})$$

Combining (C.6–C.7), we conclude that $\lim_{\beta \rightarrow \infty} \mu_\beta(\mathcal{U}_{>L})/\mu_\beta(\mathcal{S}) = 0$ if and only if

$$\lim_{\beta \rightarrow \infty} |\Lambda_\beta| e^{-\Gamma_{L+1}} = 0. \quad (\text{C.9})$$

■

C.2. Kawasaki.

Proof. Split

$$\mathcal{S} = \mathcal{S}_L \cup (\mathcal{S} \setminus \mathcal{S}_L) = \mathcal{S}_L \cup \mathcal{U}_{>L}, \quad (\text{C.10})$$

where $\mathcal{U}_{>L} \subset \mathcal{S}$ are those configurations σ for which there exists an x such that $|\text{supp}[\sigma] \cap B_{L\beta, L\beta}(x)| > L$. Then

$$\mu_\beta(\mathcal{U}_{>L}) \leq \sum_{x \in \Lambda_\beta} \sum_{\sigma \in \mathcal{S}} \sum_{m=L+1}^K \mu_\beta(\sigma) \mathbb{1}_{\{|\text{supp}[\sigma] \cap B_{L\beta, L\beta}(x)|=m\}} = |\Lambda_\beta| [\varphi(\beta) + \gamma(\beta)], \quad (\text{C.11})$$

where

$$\varphi(\beta) = \sum_{m=L+1}^K \sum_{\eta \in \mathcal{X}_\beta^{(m)}} \sum_{\substack{\zeta \in \mathcal{X}_\beta^{(n_\beta-m)} \\ \eta \vee \zeta \in \mathcal{S}}} \frac{e^{-\beta[H(\eta)+H(\zeta)]}}{Z_\beta^{(n_\beta)}} \mathbb{1}_{\{\text{supp}[\eta] \subset B_{L\beta, L\beta}(0)\}} \mathbb{1}_{\{\text{supp}[\zeta] \subset [B_{L\beta, L\beta}(0)]^c\}} \quad (\text{C.12})$$

and $\gamma(\beta)$ is an error term arising from particles interacting across the boundary of $B_{L\beta, L\beta}(0)$. By the same argument as in (B.21), this term is negligible. Moreover,

$$\begin{aligned} \varphi(\beta) &\leq \sum_{m=L+1}^K \frac{\check{Z}_\beta^{(n_\beta-m)}}{Z_\beta^{(n_\beta)}} \left(\sum_{\eta \in \mathcal{S}^{(m)}} e^{-\beta H(\eta)} \mathbb{1}_{\{\text{supp}[\eta] \subset B_{L\beta, L\beta}(0)\}} \right) \\ &\leq [1 + o(1)] \mu_\beta(\mathcal{S}) \sum_{m=L+1}^K (\rho_\beta)^m \left(\sum_{\eta \in \mathcal{S}^{(m)}} e^{-\beta H(\eta)} \mathbb{1}_{\{\text{supp}[\eta] \subset B_{L\beta, L\beta}(0)\}} \right), \end{aligned} \quad (\text{C.13})$$

where in the last inequality we use Lemmas B.1–B.2. Now proceed as in (B.19–B.20), via the cluster expansion, to get

$$\begin{aligned} \varphi(\beta) &\leq [1 + o(1)] C \mu(\mathcal{S}) \sum_{m=L+1}^K \sum_{j=1}^m \sum_{\substack{2 \leq k_1, \dots, k_j \leq K \\ \sum_{i=1}^j k_i = m}} e^{-\beta[H_{k_i} + k_i \Delta - (\Delta - \delta_\beta)]} \\ &\leq [1 + o(1)] C \mu(\mathcal{S}) e^{-\beta[\Gamma_{L+1} - (\Delta - \delta_\beta)]}, \end{aligned} \quad (\text{C.14})$$

where H_k is the energy of a droplet with k particles that is closest to a square or quasi-square, $\Gamma_{L+1} = H_{L+1} + (L+1)\Delta$, and the second inequality uses the isoperimetric inequality together with the fact that $H_k + k\Delta$ is increasing in k for subcritical droplets.

On the other hand, by considering only those configurations in $\mathcal{U}_{>L}$ that have a droplet with $L+1$ particles, we get

$$\varphi(\beta) \geq [1 + o(1)] C \mu(\mathcal{S}) e^{-\beta[\Gamma_{L+1} - (\Delta - \delta_\beta)]}. \quad (\text{C.15})$$

Combining (C.11) and (C.14–C.15), we conclude that $\lim_{\beta \rightarrow \infty} \mu_\beta(\mathcal{U}_{>L}) / \mu_\beta(\mathcal{S}) = 0$ if and only if

$$\lim_{\beta \rightarrow \infty} |\Lambda_\beta| e^{-\beta(\Gamma_{L+1} - (\Delta - \delta_\beta))} = 0. \quad (\text{C.16})$$

■

APPENDIX D. APPENDIX: THE CRITICAL DROPLET IS THE THRESHOLD

In this appendix we show that our estimates on capacities imply that the *average* probability under the Gibbs measure μ_β of destroying a supercritical droplet and returning to a configuration in \mathcal{S}_L is exponentially small in β . We will give the proof for Kawasaki dynamics, the proof for Glauber dynamics being simpler.

Pick $M \geq \ell_c$. Recall from (2.7) that $e_{\mathcal{D}_M, \mathcal{S}_L}(\sigma) = c_\beta(\sigma) \mathbb{P}_\sigma(\tau_{\mathcal{S}_L} < \tau_{\mathcal{D}_M})$ for $\sigma \in \mathcal{D}_M$. Hence summing over $\sigma \in \partial\mathcal{D}_M$, the internal boundary of \mathcal{D}_M , we get using (2.8) that

$$\frac{\sum_{\sigma \in \partial\mathcal{D}_M} \mu_\beta(\sigma) c_\beta(\sigma) \mathbb{P}_\sigma(\tau_{\mathcal{S}_L} < \tau_{\mathcal{D}_M})}{\sum_{\sigma \in \partial\mathcal{D}_M} \mu_\beta(\sigma) c_\beta(\sigma)} = \frac{\text{CAP}(\mathcal{S}_L, \mathcal{D}_M)}{\sum_{\sigma \in \partial\mathcal{D}_M} \mu_\beta(\sigma) c_\beta(\sigma)}. \quad (\text{D.1})$$

Clearly, the left-hand side of (D.1) is the escape probability to \mathcal{S}_L from $\partial\mathcal{D}_M$ averaged with respect to the canonical Gibbs measure μ_β conditioned on $\partial\mathcal{D}_M$ weighted by the outgoing rate c_β . To show that this quantity is small, it suffices to show that the denominator is large compared to the numerator.

By Lemma 4.2,

$$\text{CAP}(\mathcal{S}_L, \mathcal{D}_M) \leq \text{CAP}(\mathcal{S}_L, (\mathcal{S}^c \setminus \tilde{\mathcal{C}}) \cup \mathcal{C}^+) = N |\Lambda_\beta| \frac{4\pi}{\Delta\beta} e^{-\beta\Gamma} \mu_\beta(\mathcal{S}) [1 + o(1)]. \quad (\text{D.2})$$

On the other hand, note that $\partial\mathcal{D}_M$ contains all configurations σ for which there is an $M \times M$ droplet somewhere in Λ_β , all L_β -boxes not containing this droplet carry at most K particles, and there is a free particle somewhere in Λ_β . The last condition ensures that $c_\beta(\sigma) \geq 1$. Therefore we can use Lemma B.1 to estimate

$$\sum_{\sigma \in \mathcal{D}_M} \mu_\beta(\sigma) c_\beta(\sigma) \geq |\Lambda_\beta| e^{-\beta H_{M^2}} \frac{\tilde{Z}_\beta^{(n_\beta - M^2)}}{Z_\beta^{(n_\beta)}} = |\Lambda_\beta| e^{-\beta H_{M^2}} (\rho_\beta)^{M^2} \mu_\beta(\mathcal{S}) [1 + o(1)], \quad (\text{D.3})$$

where H_{M^2} is the energy of an $M \times M$ droplet. Combining (D.2–D.3) we find that the left-hand side of (D.1) is bounded from above by

$$\left(N \frac{4\pi}{\Delta\beta} \right) \frac{\exp[-\beta\Gamma]}{\exp[-\beta(H_{M^2} + \Delta M^2)]} [1 + o(1)], \quad (\text{D.4})$$

which is exponentially small in β because $\Gamma > H_{M^2} + \Delta M^2$ for all $M \geq \ell_c$.

Acknowledgment. The authors thank Alessandra Bianchi, Alex Gaudillière, Dima Ioffe, Francesca Nardi, Enzo Olivieri and Elisabetta Scoppola for ongoing discussions on metastability and for sharing their work in progress. CS thanks Martin Slowik for stimulating exchange.

REFERENCES

- [1] G. Ben Arous and R. Cerf, Metastability of the three-dimensional Ising model on a torus at very low temperature, *Electron. J. Probab.* 1 (1996) Research paper 10.
- [2] K.A. Berman and M.H. Konsowa, Random paths and cuts, electrical networks, and reversible Markov chains, *SIAM J. Discrete Math.* 3 (1990) 311–319.
- [3] A. Bianchi, A. Bovier, and D. Ioffe, Sharp asymptotics for metastability in the random field Curie-Weiss model, preprint June 2008.
- [4] A. Bovier, Metastability: a potential theoretic approach, *Proceedings of ICM 2006*, EMS Publishing House, 2006, pp. 499–518.
- [5] A. Bovier, Metastability, in: *Proceedings of the 2006 Prague Summer School on Mathematical Statistical Mechanics* (ed. R. Kotecký), to be published by Springer, 2008.
- [6] A. Bovier, M. Eckhoff, V. Gayrard, and M. Klein, Metastability and low lying spectra in reversible Markov chains, *Commun. Math. Phys.* 228 (2002) 219–255.
- [7] A. Bovier, F. den Hollander, and F.R. Nardi, Sharp asymptotics for Kawasaki dynamics on a finite box with open boundary, *Probab. Theory Relat. Fields* 135 (2006) 265–310.
- [8] A. Bovier and F. Manzo, Metastability in Glauber dynamics in the low-temperature limit: beyond exponential asymptotics, *J. Stat. Phys.* 107 (2002) 757–779.
- [9] R. Cerf and F. Manzo, private communication.
- [10] P. Dehghanpour and R.H. Schonmann, Metropolis dynamics relaxation via nucleation and growth, *Commun. Math. Phys.* 188 (1997) 89–119.
- [11] P. Dehghanpour and R.H. Schonmann, A nucleation-and-growth model, *Probab. Theory Relat. Fields* 107 (1997) 123–135.

- [12] A. Gaudillière, F. den Hollander, F.R. Nardi, E. Olivieri, and E. Scoppola, Ideal gas approximation for a two-dimensional rarified gas under Kawasaki dynamics, EURANDOM Report 2007-043, to appear in Stoch. Proc. Appl.
 - [13] A. Gaudillière, F. den Hollander, F.R. Nardi, E. Olivieri, and E. Scoppola, Droplet dynamics in a two-dimensional rarified gas under Kawasaki dynamics, work in progress.
 - [14] A. Gaudillière, F. den Hollander, F.R. Nardi, E. Olivieri, and E. Scoppola, Homogeneous nucleation for two-dimensional Kawasaki dynamics, work in progress.
 - [15] F. den Hollander, Metastability under stochastic dynamics, Stoch. Proc. Appl. 114 (2004) 1–26.
 - [16] F. den Hollander, Three lectures on metastability under stochastic dynamics , in: Proceedings of the 2006 Prague Summer School on Mathematical Statistical Mechanics (ed. R. Kotecký), to be published by Springer, 2008.
 - [17] F. den Hollander, F.R. Nardi, E. Olivieri, and E. Scoppola, Droplet growth for three-dimensional Kawasaki dynamics, Probab. Theory Relat. Fields 125 (2003) 153–194.
 - [18] F. den Hollander, E. Olivieri, and E. Scoppola, Metastability and nucleation for conservative dynamics, J. Math. Phys. 41 (2000) 1424–1498.
 - [19] R. Kotecký and E. Olivieri, Droplet dynamics for asymmetric Ising model, J. Stat. Phys. 70 (1993) 1121–1148.
 - [20] G.F. Lawler, *Intersections of Random Walks*, Birkhäuser, Boston, 1991.
 - [21] G.F. Lawler, O. Schramm and W. Werner, Conformal invariance of planar loop-erased random walk and uniform spanning trees, Ann. Probab. 32 (2004) 939–995.
 - [22] E.J. Neves and R.H. Schonmann, Critical droplets and metastability for Glauber dynamics at very low temperature, Commun. Math. Phys. 137 (1991) 209–230.
 - [23] E. Olivieri and M.E. Vares, *Large Deviations and Metastability*, Cambridge University Press, Cambridge, 2004.
 - [24] R.H. Schonmann and S.B. Shlosman, Wulff droplets and the metastable relaxation of kinetic Ising models, Commun. Math. Phys. 194 (1998) 389–462.
- Acknowledgment.* The authors thank Alessandra Bianchi, Alex Gaudillière, Dima Ioffe, Francesca Nardi, Enzo Olivieri and Elisabetta Scoppola for ongoing discussions on metastability and for sharing their work in progress. CS thanks Martin Slowik for stimulating exchange.