

Vaasan yliopisto  
UNIVERSITY OF VAASAOSUVA Open  
Science

This is a self-archived – parallel published version of this article in the publication archive of the University of Vaasa. It might differ from the original.

## Active and reactive power requirements at DSO-TSO interface : a cases study based on four European countries

**Author(s):** Kadam, Serdar; Schwalbe, Roman; Übermasser, Stefan; Groß, Christoph; Einfalt, Alfred; Laaksonen, Hannu; Sirviö, Katja; Hovila, Petri; Blažič, Boštjan

**Title:** Active and reactive power requirements at DSO-TSO interface : a cases study based on four European countries

**Year:** 2018

**Version:** Publisher's PDF

**Copyright** ©2018 International Conference and Exhibition on Electricity Distribution CIRED

### Please cite the original version:

Kadam, S., Schwalbe, R., Übermasser, S., Groß, C., Einfalt, A., Laaksonen, H., Sirviö, K., Hovila, P., & Blažič, B., (2018). Active and reactive power requirements at DSO-TSO interface : a cases study based on four European countries. In: *CIRED Workshop Proceedings : Microgrids and Local Energy Communities, Ljubljana, Slovenia, June 7-8, 2018*, paper 0406. [http://www.cired.net/publications/workshop2018/pdfs/Submission%200406%20-%20Paper%20\(ID-21039\).pdf](http://www.cired.net/publications/workshop2018/pdfs/Submission%200406%20-%20Paper%20(ID-21039).pdf)

## ACTIVE AND REACTIVE POWER REQUIREMENTS AT DSO-TSO INTERFACE A CASES STUDY BASED ON FOUR EUROPEAN COUNTRIES

Serdar Kadam, Roman Schwalbe  
Stefan Übermayer  
AIT Austrian Institute of Technology  
[serdar.kadam@ait.ac.at](mailto:serdar.kadam@ait.ac.at)

Christoph Groß  
Salzburg Netz GmbH  
[christoph.groiss@salzburgnetz.at](mailto:christoph.groiss@salzburgnetz.at)

Alfred Einfält  
Siemens AG Österreich  
[alfred.einfalt@siemens.com](mailto:alfred.einfalt@siemens.com)

Hannu Laaksonen, Katja Sirviö  
University of Vaasa  
[hannu.laaksonen@uva.fi](mailto:hannu.laaksonen@uva.fi)

Petri Hovila  
ABB Finland  
[petri.hovila@fi.abb.com](mailto:petri.hovila@fi.abb.com)

Boštjan Blažič  
University of Ljubljana  
[bostjan.blazic@fe.uni-lj.si](mailto:bostjan.blazic@fe.uni-lj.si)

### ABSTRACT

*The ENTSO-E network code for demand connection sets harmonized requirements for connecting large renewable energy generation units as well as demand response facilities and furthermore reactive power limits which need to be fulfilled at the interface between TSO and DSOs. In this paper, P/Q-measurements for several primary substations in four different countries (Austria, Finland, Germany and Slovenia) are investigated. For the investigated primary substations measurements of active and reactive power over a period of one year in 15-min resolutions were collected. Based on the investigations the impact of reactive power requirements at the TSO-DSO interface is addressed. Moreover, how and on which voltage level the reactive power could be balanced is discussed.*

### INTRODUCTION

The ENTSO-E network code for demand connection (DCC), published in August 2016 [1], sets harmonized requirements for connecting large renewable energy generation units as well as demand response facilities ([1]). Article 15 of the demand connection code describes in particular those reactive power limits which need to be fulfilled at the interface between TSO and DSOs. Already today, for example, the Finnish TSO Fingrid has a guideline, where a reactive power window is defined for each DSO node connected to the transmission grid. Thereby, violations of the reactive power window are fined since the beginning of 2017 within the Finnish TSO grid [2]. In the future, this requirement will be updated according to [1]. In the project DeCAS [3], the coordination of ancillary services such as, aggregated “prosumers” response control reserve, individual voltage control and reactive power management concepts over traditional boundaries from high voltage, medium voltage to low voltage is analysed. Furthermore, requirements for generators are being defined to harmonize standards that generators must respect to be allowed to connect to the grid [4]. Already today, a high number of distributed generators (DG) connected to transmission and distribution grids are capable to provide reactive power to reduce the voltage rise and to increase the hosting capacity of distribution grids. Hence, a high number of controllable devices that could be utilized to fulfil reactive power

requirements. In [5] for example a distributed reactive power optimization algorithm is presented, that can obtain the global optimum solution based on random gradient-free algorithm for distribution network without requiring a central coordinator.

The paper is structured in the following order:

- First, the data used in this paper is discussed in the materials and methods section.
- After that, the results for each case study are presented.
- Finally the results are discussed taking directives of [1] and [4] into consideration.

### MATERIALS AND METHODS

In this section, the investigated case studies in the considered countries are described and statistics of the supplied area are given. The main characteristics are summarized in Table I. For all case studies, 1 year of measurement data (year 2016) in 15-minute resolution was investigated.

#### Description of the Austrian case study

The distribution grid in Salzburg has two connection points to the transmission grid. Therefore the 110-kV-distribution-network is operated in two independent network areas. The northern part of the 110-kV-network includes the city of Salzburg and has a comparable small amount of generation units. In contrary the southern part of the 110-kV-network includes most of the hydroelectric power plants. In the 110-kV-network most of the lines are overhead lines (93%). In the medium voltage level (30-kV and 10-kV-level) 58% of the lines are cables, which contribute the main share of reactive power generation due to the line capacitance.

#### Description of the Finnish case study

Sundom Smart Grid (SSG) in Vaasa, Finland (Figure 1) is a smart grid pilot of ABB Oy, Vaasan Sähkö (local DSO), Elisa (telecommunication company, previously Anvia) and University of Vaasa. Finnish case studies in SSG concentrates on research and development of i) future active network management (ANM) scheme and ii) related technical flexibility service market structures as well as on development of iii) future-proof islanding detection functionalities [6]. In SSG IEEE 1588 time-synchronized, more accurate IEC 61850-9-2 sampled

Table 1 Characteristics of some investigated primary substations (HV High voltage, MV Medium voltage, LV Low voltage)

Country	Scope of study case	Supplied area (km <sup>2</sup> )	Number of customers	Line Lengths (km)
Austria	TSO/DSO interface	7,053 km <sup>2</sup>	433,549	HV 595 / MV 4,322 / LV 16,705 km
Finland	TSO/DSO interface	49 km <sup>2</sup>	1,945	MV 64 km
Germany	HV/MV	1,635 km <sup>2</sup>	200,584	HV 388 / MV 1,651 km
Slovenia	TSO/DSO interface	241 km <sup>2</sup>	10,632	MV 166 km

values (SVs) and less accurate GOOSE values based, measurement data from multiple points is collected and stored in servers (Figure 1) to enable research and development of ANM, protection and islanding detection functionalities [6]. Today there are two DG units connected to SSG (Figure 1): One full-power-converter based wind turbine (3.6 MW) connected to MV network with own MV feeder J08 (Figure 1) and another LV network connected inverter based PV unit (33 kW) at MV/LV substation TR4318. Islanding detection is one of the multiple targets of the studied and developed ANM scheme [6].

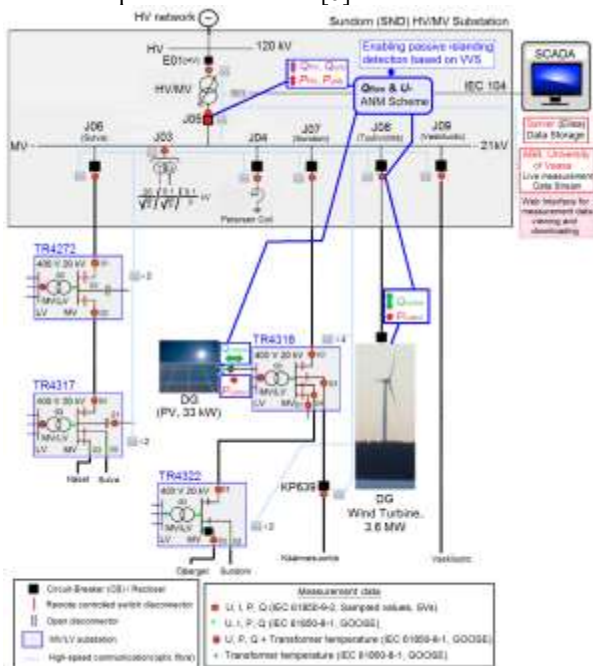

Figure 1 Sandom Smart Grid (SSG) for Finnish case studies.

### Description of the German case study

The distribution grid is located around the city Kempten and almost the area Allgäu. The nominal voltage of the distribution grid is 20kV. Within the grid area there are some smaller cities and villages, but mostly it is a very rural area. There is a high amount of power plants of different sizes. The most dominant generation type is photovoltaic but also water and wind power plants as well as combined heat and power plants. The medium-voltage network is predominantly designed as overhead lines.

### Description of the Slovenian case study

Measurement data for Slovenian case study were obtained in distribution transformer station (TS) Vrhnika, on transformers TR1 and TR2. From Vrhnika TS approximately 10,600 consumers are supplied, the population is app. 28,000 and total supplied area is app. 241 km<sup>2</sup>.

From TR1, 10 feeders are supplied, ranging in lengths from 3 km to 39 km. From TR2 only two feeders are supplied: Dragomer (length: 20.9 km and 35 LV feeders) and Grosuplje (length: 52.8 km and 55 LV feeders). The total length of all feeders, from both transformers, is 166.1 km, of which 112 km are lines and 54 km (32 % of total) are cables.

### CASE STUDIES

In this section, the 1-year time series of data measurements in 15-minute resolution provided from 4 different DSOs of 4 different countries are investigated.

### Austrian case study

The measurements of active and reactive power (P/Q measurement) and their probability density functions (pdfs) of two primary substations PS in Austria are depicted in Figure 2 (top right). The active power exchange varies between +350 MW and -280 MW where about 25 % of the values are negative (reverse power flow to the transmission grid). Active power values in the range between 70 MW to 220 MW were observed most of the time. In the case of the Austrian PSs, the difference between minimal and maximal reactive power exchange is more than 30 % of the maximal imported active power ( $P_{max}$ ). Hence, even in times of no exchange of active power at the TSO-DSO interface, a reactive power exchange in almost the full range of measured reactive power values is observed. Further results on the investigations of the Austrian case study can be found in [7]. In this paper three options to influence the reactive power flows and their potentials are investigated (change of the nominal voltage, compensation and reactive power support by means of DG).

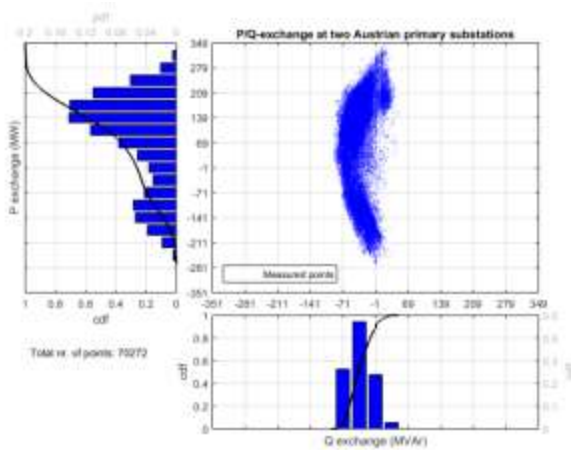

Figure 2 Measured P/Q points (Austrian case study)

### Finnish case study

The P/Q measurements and their pdfs are presented in Figure 3. In the Finnish case study, the applied reactive power window (since January 2018) is plotted in red. The number of measurements violating the reactive power window in case of the Finish PS is 31 %. The reverse power flow in terms of power and duration is little compared to the Austrian study case. For a high number of measured values, the reactive power exchange is almost independent from the active power exchange that varies between -1 and 0 MVar. For a short period of time, a higher negative reactive power exchange was observed.

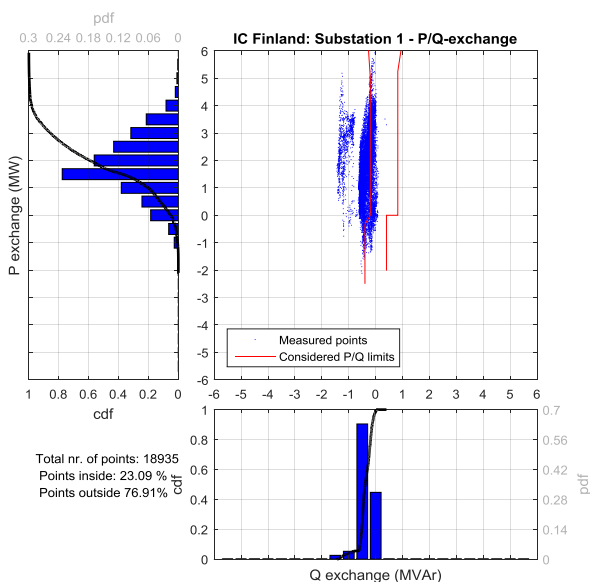

Figure 3 Measured P/Q points (Finish case study)

### German case study

The P/Q measurements of the German case study are depicted in Figure 4. In case of these measurements, the variation of the reactive power corresponds to about 48 % of  $P_{max}$ . For almost half of the time, the active power exchange at the TSO-DSO interface is above 70 MW. It was also observed that the reactive power does not

change significantly during times of reverse power flows to the transmission grid (compared to the Austrian study case). However, the reactive power exchange in times of active power consumption above 30 MW from the upstream grid, lies within a triangle. Hence, the variation of the reactive power exchange is at highest at 30 % of  $P_{max}$ .

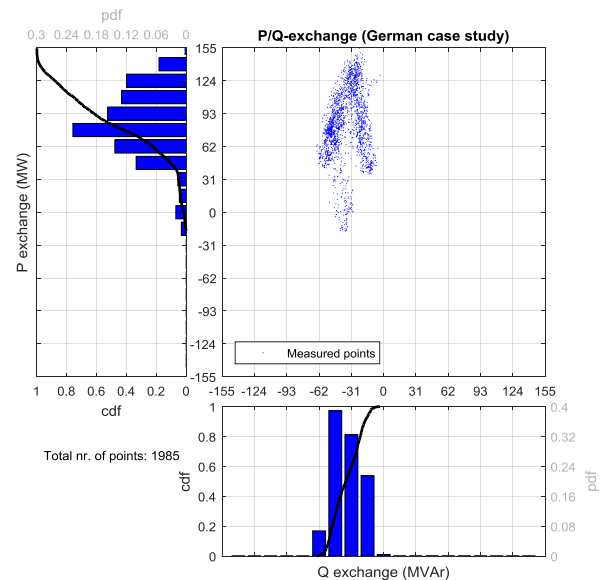

Figure 4 Measured P/Q points (German case study)

### Slovenian case study

Last but not least, the P/Q measurements for the Slovenian case study are depicted in Figure 5. Compared to the previous study cases, no reverse power flows were measured. Even the reactive power varies for fixed active power values, a linear behaviour between active and reactive power is observed. Most of the reactive power values are between -1 MVar and 2 MVar.

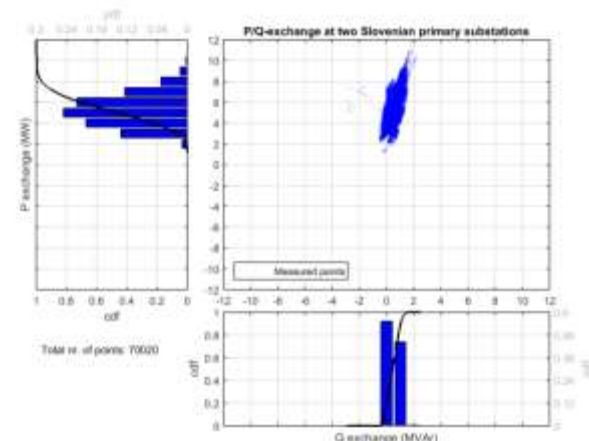

Figure 5 Measured P/Q points (Slovenian case study)

In Table II the measured minimal and maximal active power exchange with the transmission grid is summarized. The reverse power flow reaches about 78 % of  $P_{max}$  in the Austrian study case and 55 % in the

German study case. Moreover, the reactive power exchange at zero active power is listed in this table as well. Obviously, the highest delta was observed in the Austrian case study of about 100 MVar.

*Table II Selected active and reactive power exchange values at the TSO-DSO interface*

Case Study	P <sub>min</sub> (MW)	P <sub>max</sub> (MW)	Q <sub>+</sub> at P=0 (MVar)	Q <sub>-</sub> at P=0 (MVar)
Austria	-271	349	-84	16
Finland	-2	6	-1.2	0.07
Germany	-17.7	155	-45.3	-29.5
Slovenia	1.2	12	-	-

## DISCUSSION

In the previous section, selected cases studies of each country have been analyzed regarding reactive and active power flows. While the reactive power variation is rather constant near zero over the whole active power exchange in the case study of Finland and Slovenia, a high variation of the reactive power is observed in the case of the depicted Austrian and German PSs.

The results show that reactive power flows at the interfaces to the upstream network are varying significantly among the investigated case studies. One of the challenges that need to be investigated further is the reason for the reactive power variation during times of almost zero MW exchange and how the reactive power can be controlled in such situations.

This leads to the question which network components (e.g. converter of Distributed Generation units, static compensators, FACTS, etc.) on which voltage level are suitable for being utilized to fulfil reactive power requirements at the TSO-DSO interface. Thereby the identification of the control strategy (e.g. centralized or decentralized) is of high importance to ensure a cost-efficient provision of the required reactive power while minimizing the losses within the grid.

In case of several TSO-DSO interfaces between one or more TSOs and one DSO, several options to define a reactive power window would be possible. The reactive power window could be defined for each of the interfaces individually, where only the measurements at the interface are considered. The second option would be to define a reactive power window for all interfaces in consideration with each TSO, where the P/Q measurements are summed up. For each of the options another shape of the reactive power window may be reasonable.

Only in one of the four investigated network areas national directives for reactive power exist at the moment but the topic TSO-DSO interface is discussed intensively. Nevertheless, with the demand connection code in place, regulations regarding reactive power at the TSO-DSO interface will enter into force in the near future. Therefore, DeCAS will help to answer important

questions like which reactive power limits are reasonable and on which of the voltage levels (HV, MV, LV) the reactive power should/can be balanced.

## ACKNOWLEDGEMENTS

This project has received funding in the framework of the joint programming initiative ERA-Net Smart Grids Plus, with support from the European Union's Horizon 2020 research and innovation programme.

## REFERENCES

- [1] EC, *Network Code on Demand Connection*. 2016.
- [2] Fingrid, 'Supply of Reactive Power and Maintenance of Reactive Power'.
- [3] 'DeCAS project'. [Online]. Available: decas-project.eu. [Accessed: 05-Dec-2017].
- [4] EC, *network code on requirements for grid connection of generators*. 2016.
- [5] J. Xie, C. Liang, and Y. Xiao, 'Reactive Power Optimization for Distribution Network Based on Distributed Random Gradient-Free Algorithm', *Energies*, vol. 11, no. 3, p. 534, Mar. 2018.
- [6] Uebermasser, S., Groiss, C., Einfalt, A., Thie, N., Vasconcelos, M., Helguero, J., Laaksonen, H., Hovila, P., 'Requirements for Coordinated Ancillary Services Covering Different Voltage Levels', 24<sup>th</sup> International Conference on Electricity Distribution (CIRED 2017), Glasgow, Scotland, 12-15 June, 2017.
- [7] C. Groß, D. Grubinger, and R. Schwalbe, 'Blindleistungsbilanz im Salzburger Verteilnetz', in *15. Symposium Energieinnovation*, Graz, Austria, 2018.