

World Maritime University

# The Maritime Commons: Digital Repository of the World Maritime University

---

World Maritime University Dissertations

Dissertations

---

1985

## Proposal for legislation concerning offshore mobile units in India

R. S. Panwar

*World Maritime University*

Follow this and additional works at: [https://commons.wmu.se/all\\_dissertations](https://commons.wmu.se/all_dissertations)

---

### Recommended Citation

Panwar, R. S., "Proposal for legislation concerning offshore mobile units in India" (1985). *World Maritime University Dissertations*. 1298.

[https://commons.wmu.se/all\\_dissertations/1298](https://commons.wmu.se/all_dissertations/1298)

This Dissertation is brought to you courtesy of Maritime Commons. Open Access items may be downloaded for non-commercial, fair use academic purposes. No items may be hosted on another server or web site without express written permission from the World Maritime University. For more information, please contact [library@wmu.se](mailto:library@wmu.se).

WORLD MARITIME UNIVERSITY  
MALMÖ, Sweden

PROPOSAL FOR LEGISLATION  
CONCERNING OFFSHORE MOBILE  
UNITS IN INDIA

by

R.S. Panwar

India

November 1985

WMU LIBRARY

A dissertation submitted to the World Maritime University in partial fulfilment of the requirements of a Master of Science degree in MARITIME SAFETY ADMINISTRATION (MARINE ENGINEERING).

The contents of this paper reflect my own personal views and are not necessarily endorsed by the UNIVERSITY.

Signature:

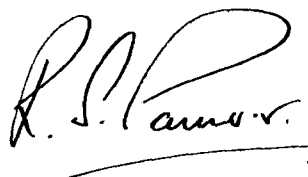

Date: 01 November 1985

Supervised and assessed by:

T.F. BALMER

Professor World Maritime University



Co-assessed by:

Mr E.J. SALVESEN, Director of Department

Norwegian Maritime Directorate

## ABSTRACT

This paper begins with briefly tracing the history and development of Offshore Industry in general and then goes on to explain the present status of India's involvement in it with projected future plans. It further, proposes a definite legislation and regulatory system to cover the new breed of vessels and units engaged in such activities in place of make shift arrangements followed so far.

The system proposed is based on a study of what is being followed in United Kingdom and Norway with suitable modifications to suit prevailing conditions in India. This regulatory system would enable the country to execute it's much needed programme of exploration and exploitation of offshore oil in a manner which will ensure greater safety of these vessels, personnel engaged in these operations and protection of marine environments.

TABLE OF CONTENTSPage No.

I	INTRODUCTION	1
II	DEVELOPMENT OF OFFSHORE INDUSTRY	5
	2.1.Offshore Oil Drilling & Production Platforms	5
	2.2.Offshore Supply And Support Vessels	12
III	OFFSHORE ACTIVITIES IN INDIA	22
	3.1.Brief History	22
	3.2.Present Activity	23
	3.3.Future Plans	25
IV	COMPARATIVE STUDY OF SHIPPING & OFFSHORE ACTIVITY	29
	4.1.Composition of Types of Vessels in Each Case	29
	4.2.Technical & Operational Comparison	30
V	NEED FOR CONTROL	34
	5.1.Philosophy of Control	34
	5.2.Accidents & lessons learnt	35
	5.3.Financial Implication of Accidents/ Casualties.	39
VI	OFFSHORE ACTIVITIES	42

6.1.	Definition of Offshore Activity	42
6.2.	Details of Activities	44
6.3.	Main Areas of Offshore Oil Activity	46
6.4.	Regrouping of Main Areas For Govt. Control	49
VII	CONTROL SYSTEM IN UNITED KINGDOM AND NORWAY	53
7.1.	United Kingdom Control System	53
7.2.	Norwegian Control System	54
7.3.	Pros And Cons of U.K. & Norwegian Systems	58
7.3.1.	Control System In United Kingdom	58
7.3.2.	Control System In Norway	59
VIII	PROPOSED LEGISLATION	61
IX	CONCLUSION	65
	APPENDICES	67
	Appendix I	67
	Appendix II	69
	Appendix III	71
	REFERENCES	73
	TABLES	75
	FIGURES	76

## LIST OF TABLES

	Page No.
I Capabilities of various types of drilling units.	11
II Construction cost of drilling units.	12
III Growth in size of offshore support vessels.	15
IV Particulars of Indian offshore vessels on order.	26
V World statistics on offshore accidents from 1970 to 1976.	36
VI Per unit cost of industrial accidents in U.K. in 1974.	69
VII Cost of industrial accidents in U.K.(1972 report)	70
VIII Cost of accidents in U.S.A in 1965.	71
IX Cost of accidental injuries in U.S.A. excluding material damage costs.	72
X Zones and limits under "THE LAW OF THE SEA "	43

## LIST OF ILLUSTRATIONS

		Page No.
Figure-1	Crude oil prices.	6
Figure-2	Various types of semi-submersible drilling units (1965 to 1983).	10
Figure-3	Development of supply vessels.	16
Figure-4	Dynamic positioned vessel.	17
Figure-5	Stand-by vessel.	19
Figure-6	Sub-sea construction vessel.	20
Figure-7	Super supply ship.	21

## I INTRODUCTION

The history of offshore oil activities in the world, is rather short and is not more than fifty years old. It was in late 1930's, in the Gulf of Mexico that these activities took birth. The initial development was rather poor and progress was slow till the oil crisis of 1973. The main reasons which could be attributed for the poor and slow progress, were as follows:-

1. Inadequate development of offshore oil exploratory technology
2. Lack of interest or enthusiasm, on the part of people and government, due to abundant supply of oil from shore installations.
3. Low demand for offshore oil, as shore operations could meet the requirements economically.

However, as far as India is concerned the history of offshore oil industry is still in its infancy. This was because it was only after India became independent in 1947, that her first British educated prime minister Pandit Jawaharlal Nehru dreamt to transform India from an agrarian society to a modern industrial nation. It was only in 1976 that India pumped her first barrel of offshore commercial oil into Motor Tanker "Jawaharlal Nehru" from Bombay High oil field. Similarly, other offshore activities, such as oceanographic research, fisheries research and the search for minerals on the sea bed, are relatively still younger.



Since the offshore operations are still in their infancy, the country requires a proper legislation and rules thereof to fulfil the national interest in the search for and exploitation of mineral resources on the continental shelf / exclusive economic zone.

There are three main areas where control of offshore operations, is essential, namely:-

1. to secure the efficient exploitation of natural resources;
2. to ensure the safety, health and welfare of persons engaged in the operations and
3. to prevent pollution arising from offshore operations.

Owing to advancement in technology and a pressing demand for minerals, food and energy these operations have been taken further away from shore into deeper water and in adverse environmental conditions. This involves very complex design configuration and also a complex operational procedure. It has caused great difficulties even to advanced and developed countries to deal with the safety of these operations in a simple straight forward manner. Since it is basically an industry operating in the marine environment, it involves both industrial and marine operational hazards.

Recognizing that no country has any one single agency to deal with all the aspects of offshore operations and to create one which will be able to handle all the aspects, will be an additional burden on the exchequer. Accordingly based on their

social ,administrative and political structure ,a number of national governments have authorised one or more departments that would be responsible for safety and safe operations of these activities. In India , due to lack of experience in the field,and due to social,administrative and political structure it has not been possible to exercise smooth and systematic control of it's offshore operations,for example :-

- 1.registration of these vessels,
- 2.type of control,
- 3.safety equipment ( i.e. Life saving appliances and Fire fighting appliances ) requirements and their periodic survey etc.

All floating vessels operating beyond inland water and port limits are required to be registered in a similar manner as conventional commercial vessels under Merchant Shipping Act. They are classified into existing classes of ships ,the requirements of which may or may not be adequate for the purpose of safety of these vessels or may be too stringent for compliance technically , operationally or financially.Further, survey requirements are also difficult to enforce as these vessels do not call port for a considerable length of time thus their voyage is not complete in the true sense of the Merchant Shipping Act. In certain cases during operations, for example Jack-Ups,which stay above sea water level as a fixed platform or structure ,they do not fall under the purview of marine survey in the present set of merchant shipping rules.

Instead of pointing out the problems individually and patching / rectifying them on a piece meal basis, which may or may not give the desired effect and some minor ones may be overlooked, it is proposed that an entirely new approach should be adopted to study the problems of the Offshore Industry.

This paper analyses the cost of industrial accidents for emphasising the need for control of offshore operations. It then analyses the control procedures of two leading nations and finally proposes an entirely new legislation for the purpose of control of safety of offshore operations and safety of persons engaged in these activities.

## II THE DEVELOPMENT OF OFFSHORE INDUSTRY IN THE WORLD

### 2.1. Offshore Oil Drilling rigs and production platforms.

Since the mid 1970's the world economy has been declining as a result of rapid rise and subsequent instability in oil prices, which are controlled to a large extent by Oil Producing Countries ( O.P.E.C.). Figure-1 shows the rise in oil prices since 1973. It will be observed from the figure that there were two major oil price shocks, namely, in 1973 and 1979, when there was a dramatic four fold increase in the price of oil. The effect of these oil price shocks, led to a serious global search for new sources of energy and a lot of development took place during the last decade in the field of Nuclear Energy, Solar Energy and Oil Exploration.

The first two alternate sources of energy, reduced the demand for oil, while increase in oil exploration, made several countries more self reliant and gave a certain amount of relief from dependency on OPEC countries. In a number of countries, there was a growth of nuclear power and solar energy plants. In many of the industrially advanced countries, where the land has been thoroughly explored and exploited to its maximum limits, there was no alternative, but to turn to the sea for their needs. The sea had to be exploited for food, minerals and energy.

The oil industry in turn, had to extend its frontiers from drilling activities inland to offshore areas to secure an

## Arabian Light Crude Oil Prices

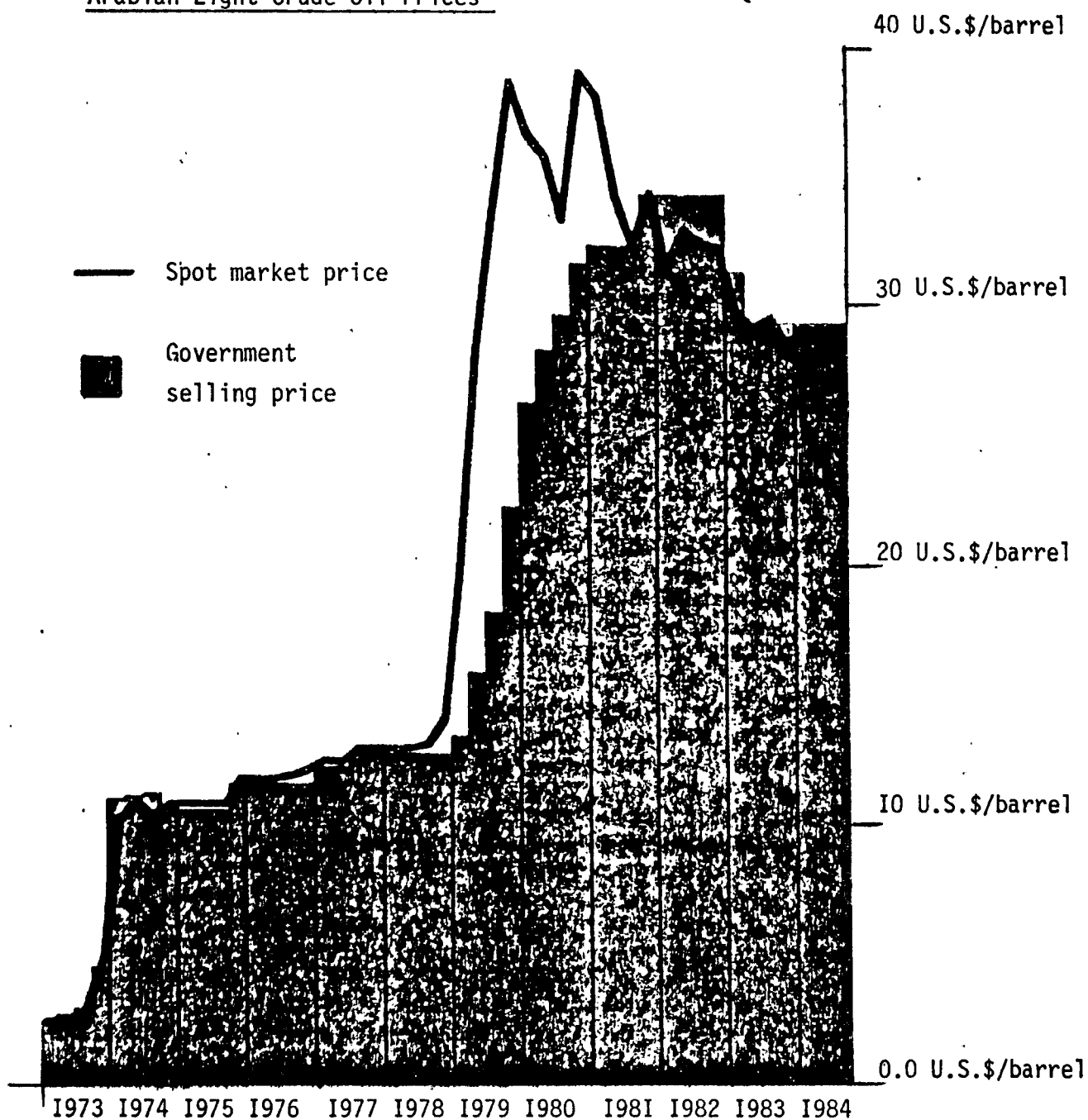

Note: i) Oil price, as reflected by the price for Arabian Light, rose sharply at the end of 1973, from slightly under \$3 to \$11, and again during 1979. The maximum spot price of over \$38 was reached at the end of 1980.

ii) Since 1981 the spot price has dropped sharply in the face of prolonged over supply and in response to reduced demand following improved energy conservation and substitution by other fuels in some markets.

Figure-I: Crude Oil Prices

available source of energy for the future. The first offshore wells were drilled in the lakes and swamps of the North American continent in the 1920's (1). Later, drilling of offshore wells gradually extended to the shallow waters of the Gulf of Mexico, in the late 1930's.

The first offshore wells were drilled by the use of piled structures. In the late 1940's the first mobile drilling units based on flat bottomed barges were used. These were first towed to site and ballasted to the sea bed in water depths upto 9 metres.

However in the early 1950's, water depth capability of offshore drilling units was further enhanced with the advent of Jack-up and Submersible drilling units. Both these were bottom supported i.e. rested on the sea bed whilst operating. The submersible consisted of a fixed height deck structure supported by several columns attached to a barge or pontoon structure. Once on site or location, the submersible was ballasted down to the sea bed to remain in position whilst a jack-up used a different principle. It consists of a floating deck structure which is raised or lowered by its own legs to a sufficient height above the sea level whilst her legs rest on the sea bed during operation.

The middle of 1950's saw a new concept of a drillship based upon drill barges. This development provided improved mobility and increased water depth capability. The first drill ships were conversions of existing cargo ships and had a large deck

load capability which made them extremely suitable for drilling operations in deep waters or remote areas. However, these drill ships with conventional hullform, had poor ship motion characteristics in bow, quarter and beam seas. Hence, drilling operations in stormy weather could not be carried out, where as jack-ups could continue drilling under similar weather conditions.

In as early as the 1960 's a few designers working on a submersible design evolved a new version called semi-submersible. The major difference is that the semi-submersible units floats and maintains it's position with the aid of mooring anchors. The latest version of these semi-submersible drilling units ( S.S.D.U.) have more than one system for maintaining their position ie. 1) by mooring anchors, 2) by dynamic positioning and 3) by mooring and dynamic positioning, or some times, tension legs are used. The structural arrangement of the S.S.D.U. consists of a large deck structure supported by columns attached to large underwater displacement hulls. The purpose of the design is to reduce the effects of wave action and improve ship motion characteristics by positioning the displacement hulls approximately fifteen metres below the sea level.

Today's drill ship, specially designed for the purpose (i.e. exploratory drilling), are capable of carrying out drilling operations in water depths of over 1800 metres.

The submersible is principally operated in the Gulf of Mexico, while the other types of mobile drilling units are operated

world-wide. Figure 2 shows the development of semi-submersible drilling units from 1965 to 1983. The first Sedco 135 semi-submersible drilling rig was designed as a bottom supported drilling rig and could sit on the sea bed, down to 41 metres of water depth, while present design of semi-submersible are capable of working as stated earlier, in depths of 1800 metres. In order to exploit marginal offshore oil or gas fields, M/S Seaforth Maritime Ltd., M/S. Taywood Santa Fe Ltd. and M/S. Taywood Engineering Ltd. of offshore development group, have developed TAPS (Turret Anchored Production System) offshore oil production system for exploitation in the most economic way (2). The Turret Anchored Production System (TAPS) is a production platform, storage tanker and an off-loading buoy, all combined into a single unit. The principal particulars of TAPS (100m. water depth) are as under :-

Length overall	250m.
Breadth	41m.
Depth	25m.
Draught	15m.
Crude oil storage capacity	70000 Tonnes
Deck pay load for process equipment	10000 Tonnes

This research and development programme was funded jointly by the E.E.C., the U.K. Department of Energy and the O.D.G. (Offshore Development Group). However, the basic design concept of TAPS is that of a barge / ship, i.e. monohull type. Meanwhile, support vessels were also developed for exploratory drilling, initial installation, start-up phases of offshore production



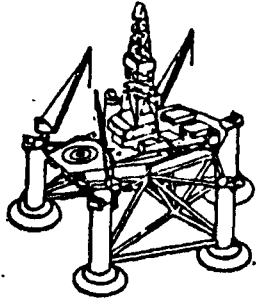

Pentagone (I969)

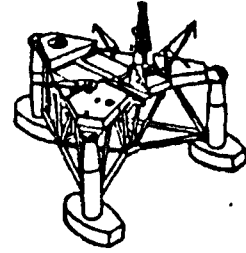

Sedco I35 (I965)

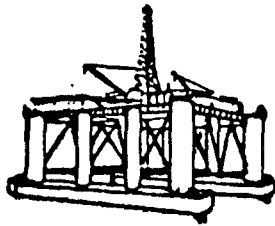

Sedco 700 (I973)

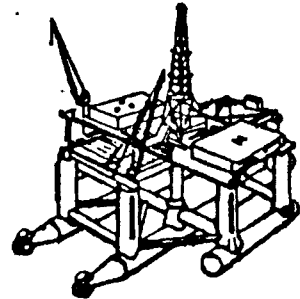

Ocean Victory (I972)

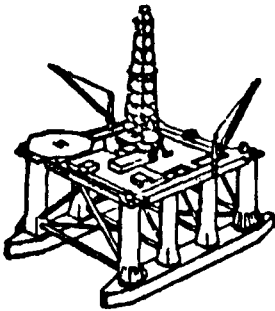

Aker H-3 (I974)

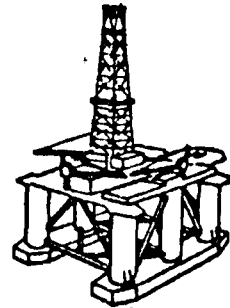

Pacesetter (I973)

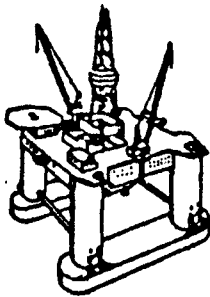

GVA 4000 (I983)

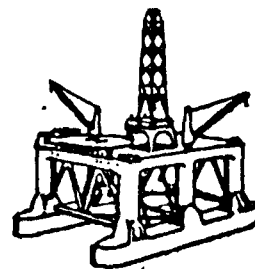

Bingo 3000 (I982)

Figure-2: Various Type of Semi-submersible  
Drilling Units (I965-I983)

platforms and maintenance of sub-sea pipe lines etc. during the life span of production.

The approximate water depth capabilities of various types of offshore drilling units as they have developed ,are given in table-I :-

Table-I

1.Submersible	3M. to 45M.
2.Jack-Ups	3M. to 100M.
3.Drill Ship (moored)	30M. to 450M.
4.Drill Ship (dynamically positioned)	120M. to 1800M.
5.Semi-Submersibles (moored)	45M. to 600M.
6.Semi-Submersibles (dynamically positioned)	120M. to 1800M.

The above figures are a rough guide as the actual capacity of a drilling unit is dependant on the environmental forces likely to be encountered.

Table-II below ,gives the approximate cost of construction of drilling units,in million U.S. dollars :-

Table-II

Year	Jack-Ups		Semi-Submersibles		Drill Ship	
	shallow	deep water	shallow	deepwater	moored	D.P.
1972	7to 8	9.5to 10.5	20to 25	-----	10to 12	20to 22
1975	18to22	20.0to 25.0	30to 42	-----	25to 30	40to 55
1980	20to25	35.0to 45.0	73to 75	120	90	-----
1982	27to30	68.0to 75.0	100to135	180	75to130	160to180

2.2.Offshore Supply And Support Vessels

For a long time, offshore supply vessels were not considered as special purpose vessels. Hence , conversions from existing tugs and fishing vessels were quite common in shallow and sheltered waters around drilling units and platforms.

In 1955 ,for the first time,a purpose built supply vessel came on the scene in the Gulf of Mexico, having a wheel house on the fore end of the vessel ,thus leaving a large clear after deck area for carrying cargo and supplies needed for offshore plat- forms ( drilling, processing etc. ). However, very shortly it was observed that these supply vessels did not have adequate sea keeping qualities to withstand the severe weather conditions of the North sea. Hence , a new approach to re-design supply vessels with better sea keeping qualities was developed in Northern Europe.

This made the Scandinavian and North European ship building industry, which already had a long and great experience in

building small ships for rough seas ,to build larger supply vessels with dramatically reduced motion responses and increased manoeuvrability.

Development never stops and probably more technological effort is being introduced into the design of the supply vessel today than ever before.

The need for longer transportation distances and anchor handling of larger and heavier semi-submersible oil rigs,platforms and other new functions introduced in the seventies, such as stand-by,diving support,fire-fighting,oil recovery,maintenance heavy lifts ,construction ,oil well services ,cement and mud transportation , bulk liquid chemical and oil transportation etc.,has led to the development of several types and standards of support vessels.Vessels of today ,are much larger both in size and power than their predecessors.They are often highly specialized and designed to carry out specific operations.

Almost every support vessel of today is providing more than one function.In addition to its main function such as transport supplies,and assistance in maintenance work etc. they are equipped for additional functions,such as,fire fighting,towing diving support etc.to increase the flexibility and applicability of the vessel.However ,optimum combinations of fuctions depend to a great extent on the main function for which the vessel is intended.For example ,stand-by vessels which are to be considered as part of the first line of defence with a primary function to save life ,cannot combine fire-fighting and

rescue operations simultaneously. Fire-fighting invariably has to be carried out from the windward side ,while rescue operation is generally carried out from the leeward side.

Similarly , diving support is also a function difficult to combine with other functions which may be called upon at short notice ,because ,if under-water work is in progress ,it would take a number of hours to stop work and to bring the divers up. Further, it will not be feasible and may be dangerous to commence emergency operations with divers in pressure chambers.

Table-III below ,gives the increase in size of support vessels with the passage of time :-

Table-III

Year	1969	1973	1979	1983
<u>Dimensions</u>				
L.O.A.	54.00m	60.00m	65.00m	70.00m
Breadth	11.60m	13.10m	13.80m	16.00m
Depth	4.20m	4.40m	5.75m	6.50m
Dwt.	800tons	1100tons	1800tons	2600tons
Deck load	300tons	500tons	700tons	800tons
<u>Capacities</u>				
Dry bulk	105cu.m	170cu.m	227cu.m	283cu.m
	3690cu.ft.	6000cu.ft.	8000cu.ft.	10000cu.ft.
Drillwater	400tons	400tons	540tons	730tons
Potable water	50tons	200tons	450tons	670tons
Fuel oil	200tons	400tons	900tons	900tons
Power BHp.	2400	6700	8100	14000
Bollard- pull	30tons	75tons	90tons	150tons
<u>Thrusters</u>				
Bow	1	1	1	2
Stern	0	0	0	1
Winch Static pull	80tons	150tons	250tons	300tons

Figure-3 shows the development of supply vessels.

Figure-4 shows a dynamic positioned vessel.

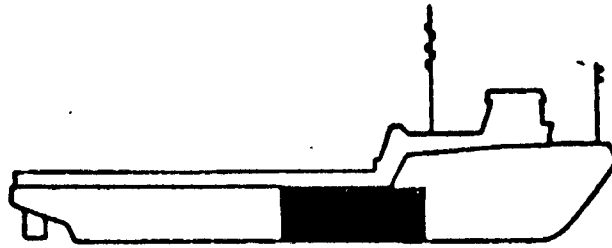

1<sup>st</sup> Generation

L-56.0 m., B-11.5 m., D-5.0 m..

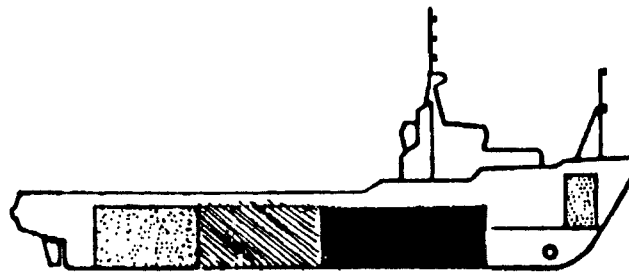

2<sup>nd</sup> Generation

L-58.0 m., B-12.0 m., D-5.0 m..



3<sup>rd</sup> Generation

L-85.0 m., B-12.0 m., D-5.0 m..

	<u>Engine Room</u>		<u>F.O.</u>
	<u>Cement / Mud</u>		<u>DW / WB</u>

Figure-3: Development of Supply Vessels

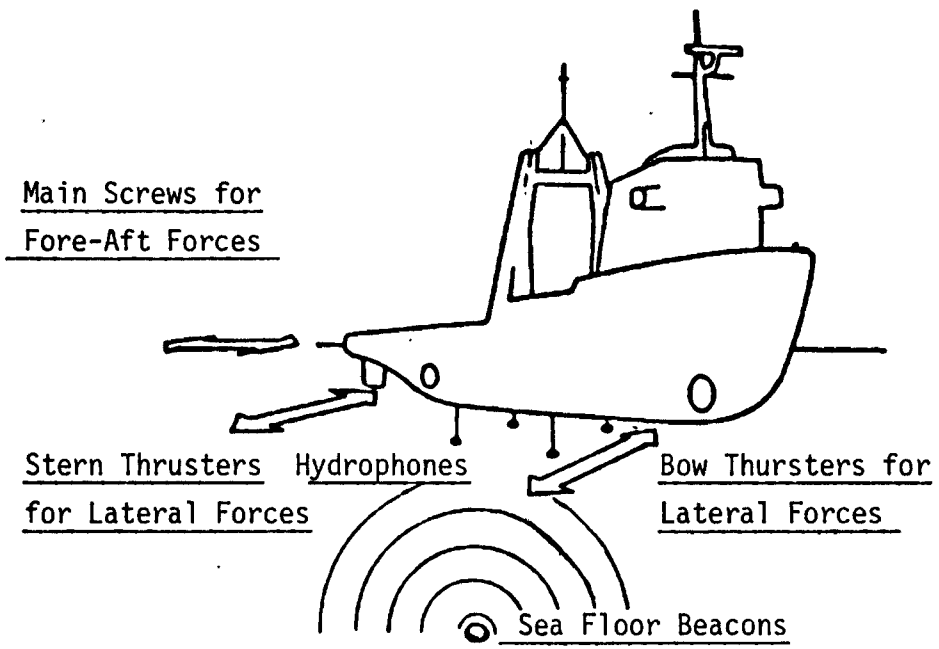

Figure-4: Dynamic Positioned Vessel



Figure-5 shows a stand-by vessel.

Figure-6 shows a sub-sea construction vessel.

It is interesting to note that Engineers ,Peter Noble & James Duerr of Marine Technology Corporation ,based in Houston ,have developed a Super Supply Ship to meet the future needs of the Beaufort sea ,for a high powered and ice worthy work boat ,to aid in rig moves ,caisson towing ,resupply and ice management (3).The vessel's specifications are as follows :-

L.O.A.	150.88M./495ft.
Breadth	21.34M./ 70ft.
Depth	11.89M./ 39ft.
Draught	9.14M./ 30ft.
Power (B.Hp.)	40000.
Fuel capacity	4150tons.
Dead weight	6600tons.
Displacement	19850tons.

Figure-7 ,shows the profile of the vessel and also it's power versus Ice thickness curve,for a speed of three Knots.

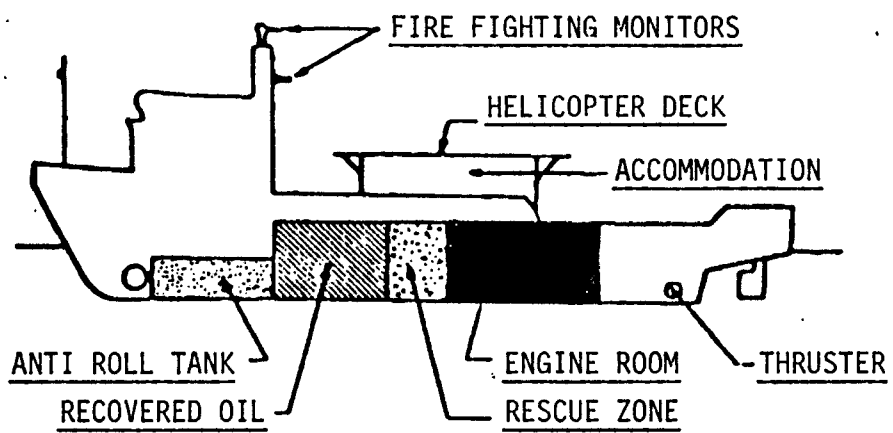

Figure-5: Stand-By Vessel

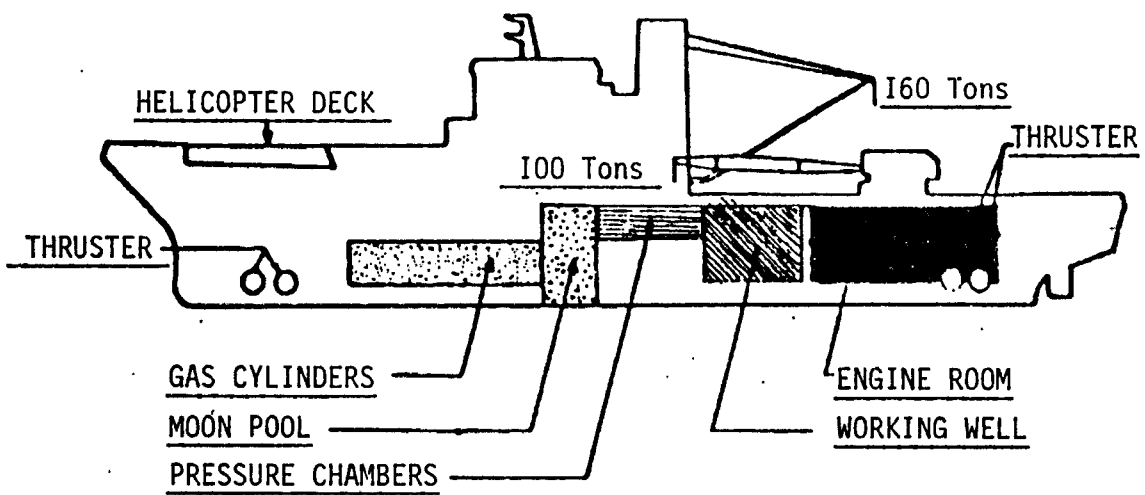

Figure-6: Subsea Construction Vessel

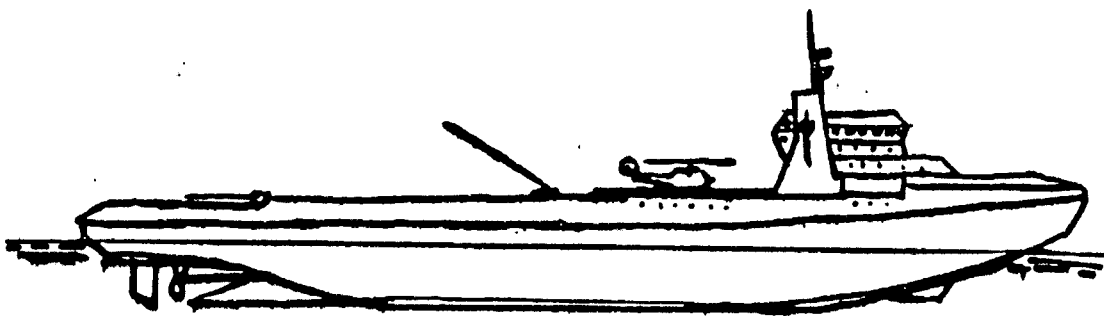
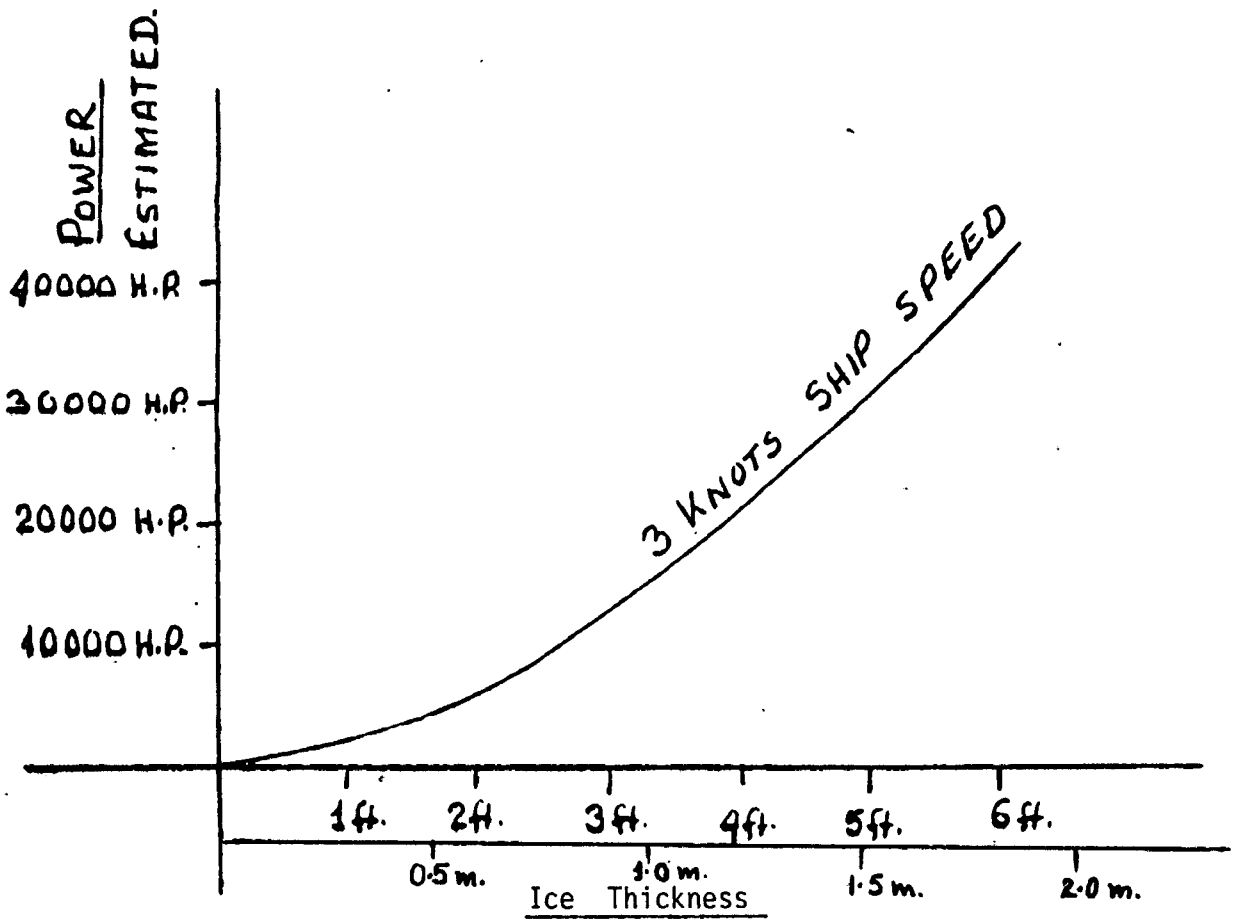

Figure-7: Super Supply Ship

### III OFFSHORE ACTIVITIES IN INDIA

#### 3.1. Brief History

In 1955 ,the Government of India created a petroleum division within the Geological Survey of India.This division soon grew into the Oil and Natural Gas Directorate, on 14th August 1956. By 1959 ,The Oil and Natural Gas Commission was made a statutory body by the Government.This marked a beginning for India, in the systematic search for oil, with The Oil And Natural Gas Commission at the helm.

In 1866 the first attempt was made to search for oil in India (4).Wells were drilled in upper Assam ,but initial attempts were sporadic, with wild cat strikes.Today, oil exploration is a country wide operation ,planned and co-ordinated by The Oil and Natural Gas Commission.In the past 25 years,this quest for oil has taken India to vastly diverse areas climatically and geographically ,from the deserts of Jaisalmer to the tropical forests of Assam ,from Kutch in the west to the Sunderban in the east ,from the snowy peaks of the Himalayan region to the depths of the Bay of Bengal and Arabian sea.

Initially ,survey and exploration activities were confined on land only (i.e. geophysical and seismic surveys ).Today India employs servo-hydraulically controlled mechanical vibrators instead of dynamite which was used earlier , to create explosions for seismic survey.Mechanical vibrators made it possible to carry out surveys even in densely populated areas.

### 3.2. Present Activity

India was no exception to the world energy crisis, she too diversified her drilling activities from land to offshore areas in the hope of becoming self-sufficient in energy.

The first offshore venture was in the shallow waters near Aliabet in the Gulf of Cambay which was undertaken by Indian engineers using indigenous technique ( i.e. using no imported equipment or technology), right from the design, fabrication and erection of a fixed platform.

On 31st. January 1974, India's first self propelled Jack-Up drilling platform " Sagar Samrat " began drilling in Bombay High , a prospective oil field off Bombay. After three weeks of drilling , oil was struck in a lime-stone reservoir and on 21st May 1976 , the first barrel of commercial oil was pumped into the dedicated storage tanker " Jawaharlal Nehru ". Since then , hectic activity of oil exploration started in India on her 4000 miles of coast line. By the end of March 1981, 156 offshore wells were drilled and tested by O.N.G.C. (Oil and Natural Gas Commission ) and of which , 115 proved hydrocarbon bearing.

Indian offshore exploration has now expanded from the Gulf of Cambay on the west coast of India to the Coromandel Coast and from areas off the Krishna Godavari Delta on the east coast of India to South of Sunderbans.

Presently, India meets 73% of her total oil needs indigenously. Given below are some facts about the Indian oil production :-

Present production of oil is about 0.5 Million barrels/day.  
Offshore production of crude oil in 84-85...20.3 M.Tons.  
Offshore production of gas in 1984-85...1819M.cu.m./day.  
Number of wells drilled offshore.....270  
Number of wells flowing offshore.....165  
Number of well platforms.....54  
Number of process platforms.....4  
Number of well cum process platforms.....6  
Number of offshore drilling rigs.....8  
Number of offshore supply vessels.....over 50

Apart from exploring offshore areas and tapping sub-sea oil, training programmes have been successfully developed. Further, this technology has been shared with other developing countries, by training a number of scientists and engineers from Iraq, Malaysia, Philippines, Nigeria and Tanzania. Further, sharing of operations in oil fields abroad, commenced in 1965, when, for the first time, together with Italy and United States of America India participated in oil exploration in Persian Gulf. However, in 1976 and 1979 India assisted Tanzania and Iraq in oil exploration single handed. Thus, India shares its expertise in petroleum technology with other developing nations.

Development of construction of offshore vessels, commenced by building oil drilling rigs at "Hindustan Shipyard" at Vishakhapatnam and supply vessels at "Mazagoan Docks, Bombay";

"Hooghly Dock And Port Engineers, Calcutta"; "Garden Reach Ship-builders And Engineers, Calcutta" and "Goa Shipyard, Goa" (5). Thus an indigenous offshore ship building industry is also being developed.

### 3.3. Future Plans

India has planned not only for search, exploration and tapping of sub-sea oil but also for mineral mining and development of deep sea fishing. On the offshore energy side, plans are in hand to launch a major exploration effort in the second category areas. However, even if the extent of drilling progresses according to plans, the density of wells by the end of the century, will still be only 70 to 80 per 10000 square Kilometres. This would compare favourably with the current world average number of wells per 10,000 square Kilometres in sedimentary basins (6). However, this figure would still be well below the U.S. average of 450 wells per 10,000 square Kilometres.

In order to fully exploit the existing reserves, it is envisaged that sixty or more offshore platforms will be required to be set up in the next five years. These offshore platforms are essential if self sufficiency in energy requirements is to be achieved by the year 2000 A.D.

In order to achieve the afore-mentioned goal, it is planned to procure fifteen new drilling rigs within the next five years. Projections covering the years between now and the end of the decade, show that the Oil and Natural Gas Commission would



require to charter ,in addition to their own drilling rigs, drilling equipment equivalent to " 47 Rig Years ".The cost of chartering these drilling rigs ,has been estimated to be about U.S.dollars 671 million.

According to the expectations of offshore industry personnel, there could be between 30 to 40 offshore drilling rigs employed on the east coast of India (i.e. in Bay of Bengal) by the 1990's.Further ,they also expect that more than a hundred supply and support vessels will be needed.

Government has already taken a step in this direction by ordering one Jack-Up drilling rig and one self propelled anchor-moored drill ship at Osaka Works of Hitachi Zosen in Japan.The particulars of these vessels are given below in table-IV.

Table IV

Name of vessels	Sagar Ratna	Sagar Vijay	Sagar Bhusan
Type of vessels	Jack-up Rig	Drill ship	Drill ship
<u>Description</u>			
L.O.A.	60.00m.	136.8m.	136.8m.
Breadth	61.00m.	24.5m.	24.5m.
Depth	7.00m.	11.2m.	11.2m.
Draught	4.15m.	6.7m.	6.7m.
Leg lengths (3)	128.00m.	-----	-----
Service speed	-----	10 Knots	10 Knots
Operating depth.	91.44m.	300.0m.	300.0m.
drilling depth.	6096.00m.	6000m.	6000m.

Drill ship "Sagar Bhusan" is being built by Hindustan Shipyard, at Vishakhapatnam (India) and will be delivered in 1986 (7).

The above specifications of drill ships indicates that there will be an expansion of offshore oil exploratory activities further away from shore into deeper waters.

Offshore activities have also expanded into oceanographic research. There are four dedicated research vessels to carry out survey and research for exploitation of the sea and sea bed for minerals and living organisms. The present fleet of research vessels is as follows:

1. Sagar Kanya.....Equipped with oceanographic research and laboratory facilities.
2. Sagar Manthan....Specially fitted for geological survey of sea bed and exploration of minerals.
3. Gaveshani..... Same functions as one above.
4. Sagar Sampada....Equipped for research on living organisms such as fishes etc.

Recently, the research vessel "Gaveshani" has discovered, in the Central Basin of the Indian ocean, nodules with a combined nickel, copper and cobalt content of 2.49 % (8). In spite of low copper content and low density, these nodules are considered to be of commercial value. The discovery of polymetallic nodules in the Indian Ocean, has encouraged the Department of Ocean Development, to make plans to venture into the area of ocean

mining by the end of the 1980's.

## IV COMPARATIVE STUDY OF SHIPPING AND OFFSHORE ACTIVITIES

### 4.1. Composition of Various Types of Vessels in Each Activity

Conventional shipping industry and offshore industry, both have a complex infrastructure, are capital intensive and an international industry. Hence, a careful consideration has to be given on all the activities which may or may not constitute high costs and are often a heavy burden. National policies play a very important role today in every industry. Movements in shipping industry are more frequent than in the case of offshore industry, but both have to face sea hazards. In certain cases, the offshore industry suffers more than conventional shipping to overcome the environmental hazards. The conventional shipping fleet consists of the types of vessel mentioned in appendix I and the full fleet is normally engaged on transporting goods and passengers and hence has frequent movements. Further, it also involves international authorities to control and check their activity. Thus these are to be governed by international standards as and when agreed by governments around the globe.

The offshore industry while in operation involves only one country or a maximum of two countries (flag country and port state country) during their operation. Their fleet need not have frequent movements in course of operation as in the case of the shipping industry, unless they have to move from one site to another site on completion of operation or abandoning of the operation. They stay for a longer time than the shipping

industry at one site , in a stationary or near stationary condition. Offshore industry fleet for all it's operations (such as drilling,production and maintenance) consists of :-

- 1.Fixed units.....(a)concrete structures  
(b)steel structures  
(c)submersibles  
(d)jack-ups with legs resting on sea bed.

- 2.Mobile units....(a)jack-ups with legs raised.  
(b)semi-submersibles (moored)  
(c)semi-submersibles (D.P.)  
(d)semi-submersibles (T.L.P.)  
(e)drill ship (moored)  
(f)drill ship (dynamically positioned)

- 3.Support vessels.(a)anchor-handling & supply vessels  
(mono hull type) (b)pipe laying & inspection vessels  
(c)diving support vessels  
(d)stand-by & rescue vessels  
(e)fire fighting & multi-purpose support  
vessels

- 4.Support vessels.(a)moored (semi-submersibles)  
(b)dynamically positioned

#### 4.2.Technical and Operational Comparision

The dissimilarities between conventional fleet ships and off-

shore crafts are :-

- i) Ships float freely while in operation, whereas offshore units may or may not have free floatation during operation.
- ii) Ships are mostly of a mono-hull design, but the same does not hold true in the case of offshore vessels.
- iii) The hull form of conventional ships has poor motion characteristics while offshore units invariably have good motion characteristics in quartering and beam seas.
- iv) Offshore units have a very complex design due to operational requirements.
- v) The general arrangement of ships is different to that of offshore units.
- vi) Offshore units move from one place/site to another site, less frequently than ships.
- vii) Further, offshore units are basically either for drilling, production, pipe laying, maintenance work on sub-sea pipes (i.e. hyperbaric welding etc.) or inspection work by using either remote operated vehicles (ROVs), divers or by diving bells/mobile diving units.
- viii) Offshore units could be called as industrial sites.
- ix) The load line convention 1966 can be applied to most of the offshore units with constraints attributed to moon-pools and other novel hull features of such units (M.O.D.U. code)
- x) Where a large mat or similar supporting structure is provided on offshore units, which contributes to buoyancy when the unit is floating, it poses special considera-

- tion when computing load line and stability.
- xi) Hull form of column stabilized units makes the calculation of geometric freeboard under the 1966 load line convention impracticable, so a different approach is required for these units.
  - xii) Bilge pumping system requirements are more stringent than on conventional ships.
  - xiii) Windows and side scuttles which face the drill floor, are fitted with inside covers of steel or equivalent material or protected by a water curtain, whereas there is no such requirement for a conventional ship.
  - xiv) Owing to excessive lift, a fire pump on an offshore unit may require a booster pump and a storage tank.
  - xv) Fire pumps of higher capacity are required for helipad protection on these vessels.

The similarities between conventional fleet ships and offshore crafts are :-

Firstly, except fixed offshore installations, all mobile units have similar effects of motion characteristics ( i.e. surge, sway, heave, roll, pitch and yaw ) to that of conventional ships. Secondly, vessels of both categories have a similar method to check structural fire protection and to calculate structural strength ( i.e. application of conventional rigid body theory of hydrostatic analysis ). Thirdly, both conventional shipping and offshore vessels have similar requirements of stability ( i.e. intact & damage stability and reserve buoyancy ), communications ( i.e. radio telegraphy & telephony, satellite communications

and V.H.F. etc.), collision prevention (i.e. navigation lights, sound & light signals), pollution prevention (i.e. by oil, sewage and garbage), bilge & ballast and crew accommodation (i.e. sleeping rooms, air conditioning, noise & vibration control, health hazards and hygienic conditions). Further, survival capabilities (i.e. fire fighting & life saving appliances and load line etc.), mooring system and the working environment (i.e. both work and stay on board at sea) are also similar in both the cases. Last and not the least, certified personnel requirements, upto a certain extent are also similar.



## V NEED FOR CONTROL

### 5.1. Philosophy of Control

In order to prevent undesirable events occurring on offshore vessels, which may lead to loss or damage to property, pollution of or damage to the environment and loss of or damage to life, there is an urgent need for exercising control.

It is obvious that the first item causes a direct situation where the nation is faced with non-availability of adequate installations. This may occur from the fact that drilling, production or transportation capability is directly reduced when damage to a structure necessitates shutting down production fully or partly.

The second item to halt production is environmental pollution. It is time consuming, laborious, difficult and a costly process to take care of a pollution incident. Both these items directly result in economic consequences, while loss of life is not so easy or acceptable to measure in economic terms.

News media of today, with the advancement of the social structure, has grown very powerful, efficient, effective and prompt to report to the public, all such instances and their side effects. Thus, public concern is aroused and strongly expressed, which leaves those responsible for safety control, in doubt, about their obligations. Increasing public awareness of marine risks and the rapid increase in the size of these risks

around the world, has led, quite naturally to increasing political involvement in the setting and monitoring of safety standards.

## 5.2. Accidents & Lessons Learnt .

Accidents in offshore industry are in no way different from accidents in any other industry, particularly marine industry. Minor accidents involving semi-submersible drilling rigs or platforms, include workboat collisions and structural cracks which are similar to the hazards encountered in other marine operations. However, major accidents, have been minimal.

There have been six semisubmersible accidents, judged as total losses, due to structural accidents when afloat, since 1961 (9). Total loss of life from all these accidents is approximately  $240 + 81 (10) = 321$  persons. This includes 123 lives lost on " Alexander Kielland " a semi-submersible drilling rig working as a floating hotel at the time of the accident, 84 lives lost on the " Ocean Ranger " another semi-submersible drilling rig and 81 men lost their lives in China sea in 1983 on " Glomar Java Sea " a drill ship. A total of ten semi-submersibles were declared as partial losses due to accidents. These include transit losses, blow outs, storm damages and boat collisions. There have been a number of accidents causing structural failure or loss of buoyancy due to an accidental flooding of compartments.

The following table, gives the break up of total losses for

offshore units in the world from 1970 to 1976.

Table V

Type of vessel	Casualty rate(i.e.total loss per hundred rig years.)
Mobile rigs.....	0.9
Jack-up rigs.....	1.4
Semi-submersibles.....	0.3
Barges.....	0.5

Two major accidents which have been reported ,that occurred recently are given below to illustrate the gravity of situation.

In march 1980, the semi-submersible oil drilling rig "Alexander Kielland" was working in the North Sea ,functioning as a floating hotel for approximately 250 persons. Storm conditions (20 to 30 feet waves) were not excessive and operations were normal. One column of this five-column semi-submersible broke loose from the lower truss members. The vessel took a 32 degree list in 15 seconds and within 20 minutes after the column broke loose, the vessel capsized. Normal ,on-site structural inspections above sea water had been conducted within the 12 months preceding the accident. However, a thorough inspection of the trusses had not been carried out, in the 4 to 5 years life of the Alexander Kielland. The structural failure which caused the accident, was traced

to a small 12 inches diameter penetration made in a eight feet diameter tubular structural truss member. Pipe insert was welded in the penetration. The welding of the pipe insert was critical, as was the placement of the penetration in the truss members. Even though the stresses were low in the truss member, the penetration and insert created a stress concentration ( multiplied stresses ) which resulted in local over stress of the truss at the weld. After repeated over stress at the stress concentration a small crack started. This small crack created an even larger stress concentration. From a crack visible to the eye to a crack that created the accident, the time was analysed to be four months.

In February 1982, the semi-submersible drilling rig " Ocean Ranger " was drilling offshore Eastern Canada in the North Atlantic Sea. An unpredicted storm which rapidly increased to 50 to 60 feet waves was encountered. These are normal winter wave conditions and are within the design criteria of the drilling units. Unknown damage resulted in large quantities of water entering the ballast control room which, on this drilling platform was located within a column below the main deck in the wave gap zone. Water in the ballast control room resulted in the ballast control unit malfunctioning due to electrical short circuiting. A series of events in the ballast system resulted in the rig taking a trim angle which was in excess of the ballast system's operating limits to de-ballast and re-trim her. Trim angles increased and the drilling rig eventually capsized and sank

The time between water short circuiting the ballast control system and the semi-submersible drilling rig capsizing and sinking was approximately five hours. The ballast and control system failure on " Ocean Ranger " which caused the accident has been determined, and several safety factors within the system were observed to be inadequate.

From the accidents mentioned above ,it is clear that design technology has to be improved further but one also learns that safety inspections must be carried out at regular short intervals. One can also see the need for better means of getting life boats safely away from these units. Lack of effective evacuation means, was the ultimate cause of loss of life. The same message is also given by Mr. Georg Kliesch head of the I.L.O. ,Occupational Safety and Health Branch, about "Union Carbide" incident at Bhopal (11).

Mr. Georg Kliesch, said that the main lesson to be learnt from the Bhopal incident is the indispensibility of a safety net in the form of safety engineers , occupational physicians and technicians. He also added that the difference between an industrialised and a developing country is that the developing nation usually lacks something which they cannot buy i.e. an infrastructure including among other things a safety system. Therefore in order to introduce new technology with safety, one needs institutions and inspection agencies which are independent of the individual companies. Only then can hazards be accurately and precisely measured and assessed. Remedial measures could be introduced to reduce the risk of accidents.

### 5.3. Financial Implication of Accidents/Casualties

Since marine data on offshore industry was not available at the time of writing this paper, data available from industry has been used to give an idea of what will be the financial implication if safety measures are not observed. Whenever an agrarian society is transformed into a modern industrial nation, it faces major changes in the working environment as a result of technical development, efficiency measures and mechanisation. Parallel to increased productivity, new and serious work-related health and safety problems arise and in some cases chronic illnesses are linked to the work place.

According to an estimate published in the "Times" of 8th. Dec. 1976, the cost of an industrial accidents in " United Kingdom " alone, for 1974, was 900 million pounds (12). However, precise figures were not published but the unit cost used in the estimate are given in the appendix II. While in United states of America the accidents cost as reported in 1965 was 18055 million U.S. dollars (this also includes accidents at home, on the roads and at work). The detail breakdown is given in appendix III.

In addition to the above statement there are hidden costs of industrial injury accidents which vary from industry to industry and therefore have to be calculated individually. These factors are given below :-

## Hidden cost factors in an accident

1. cost of lost time of injured employee.
2. cost of time lost by other employees who stop work to assist injured employee, out of sympathy, curiosity etc.
3. cost of time lost by foreman, supervisor and other executives in the following manner:-
  - i) assisting injured employee.
  - ii) investigating cause of accident.
  - iii) arranging for continuation of injured employee's work by other person or persons.
  - iv) selecting and training a replacement.
  - v) preparing official reports and attending hearings.
4. cost of time lost of employees required for interrogation into cause of accident.
5. cost of time spent by First Aiders and hospital staff not included in direct cost.
6. cost of damage to machines, tools or other property or material in process.
7. Incidental costs of lost production (i.e. failure to fill orders in time, loss of bonus or payment of penalties etc.).
8. cost under employee welfare and benefit schemes.
9. cost of full wages of employee on his return to work before his full recovery.
10. cost of loss of profit on productivity of injured employee and idle machines.
11. cost arising from excitement or low morale of other employees.

12. overhead costs of lost production caused by accident such as heat, light, ventilation etc.

Whilst the above U.S. or U.K. analysis may not completely apply in India due to differences in the social security system, for example medical assistance etc., but they still provide a useful insight into the costs of industrial accidents. Recognising the high cost involvement of accidents and the importance of safety, a nation must have control on its off-shore industries operating on her continental shelf or her exclusive economic zone.



## VI OFFSHORE ACTIVITIES

### 6.1. Definition of Offshore Activity

A brief introduction to , " The Law Of The Sea " ,in respect to a coastal state's rights ,will facilitate better understanding of offshore activity and it is therefore briefly mentioned, below (13 & 14) :-

#### Territorial Sea

Territorial sea is a belt of ocean which extends seawards from the shore line or the outward limits of internal waters of a coastal state, where a coastal state land laws can be enforced. The width of this sea from the base line has remained disputed for a long time. At the beginning of the twentieth century a zone limited to three miles had been established by most of the then existing states ,including Great Britain ,The United States of America, Germany , France and many other maritime powers. This limit of three miles, probably, grew out of the ancient " Cannon Shot " rule which effectively gave coastal state those areas of the sea that could actually lie under the protection of coastal gun batteries.

However, within a short time, the situation was changing as many coastal states began to extend their claim to distances upto 12 miles. In 1945, United States of America ,under the influence of her fishery conservation claim also began supporting the twelve miles limits for territorial waters . President Truman

however, declared yet another unrelated claim to sovereign right over the mineral resources offshore, on continental shelf. This displayed the desire of United States to have the best of both worlds, that is to be an "Expansionist" coastal state as well as a maritime power. Whereas other coastal states advocating a wider territorial sea did so for reasons of national security and fishery development and also for enforcement of customs and fiscal legislation.

In the case of newly emergent coastal states, this problem has quite different socio-economic as well as political influences. Thus, differences continued till December 1982, when at Jamaica, out of 150 countries attending the United Nation's Convention on "The Law of The Sea", 119 signed the final act of the convention with one country ratifying it. Although this convention is not yet in force, the various zone limits which are measured from the base line as described in the convention are given in table X below :-

Table X

Zones	Limits
1. Territorial sea.....	12 miles.
2. Contiguous Zone (where to prevent & punish-infringment of state's customs, fiscal, immigration or sanitary laws and regulations committed within territory or territorial waters).....	24 miles.

- 3.Continental Shelf..... Ordinarily 200.00 miles,  
but in conditions as spe-  
cified in the convention  
may be extended upto  
350.00 miles or even  
beyond.
- 4.Exclusive Economic Zone.....200 miles.

Beyond E.E.Z. ( Exclusive Economic Zone ) a Common Heritage principle has been applied , which declares that " The sea-bed and ocean floor, and the sub-soil thereof , beyond the limits of national jurisdiction as well as the resources of the area, are the common heritage of Man kind and shall not be subject to appropriation by any means by states or persons. This area shall be open to use exclusively for peaceful purpose by all states without discrimination".

Now we can easily define offshore activity as an activity which is carried out on the sea, off the shore line of a state, seawards but within the exclusive economic zone or on her continental shelf or in territorial sea. This activity may consist of scientific research, economic and commercial exploration or technological or all combined.

#### 6.2.Details of Activities

- 1.Research and development of living organisms belonging to sedentary species , that is to say , organisms which , at the harvestable stage either are immobile on or under sea-bed or

are unable to move except in constant physical contact with the sea bed or sub-soil, also that of fishing.

2.Exploration and mining of minerals.

3.Exploration and drilling for submarine petroleum resources.

The first two activities at present employ conventional mono-hull form vessels and hence their hull , machinery and equipment etc. are presently covered under passenger ship construction requirements . As the scientists involved in research are neither crew nor passengers in a conventional way , therefore full requirements of a passenger ship need not be applied. Since their size is small ,it is not possible to comply with full L.S.A. requirements of a passenger ship and secondly they are not commercial vessels ,hence compliance with all the requirements will not only increase the capital cost but would also increase the maintenance cost.For example,a deep sea passenger ship needs two hundred percent L.S.A. equipment ,whilst a cargo ship needs lesser L.S.A. equipment.Further,neither can these ships be considered as pleasure crafts.

Therefore,it is proposed that these vessels may be classed as a separate class of their own and Merchant Shipping Act should be extended to cover them for all practical purposes like any other vessels in their respective class,i.e. regular survey and inspection.

Accordingly ,a legislation to this effect may be passed empo-

wering the Ministry of Shipping to make rules for their safety and operation .

However, in the case of the last category (i.e. exploration and production of sub-sea oil ) it is not that simple due to a variety of complex configurations used in design and operation of these offshore platforms. These will be discussed in detail hence-forth.

Oil industry , which is the only industry involved in exploratory drilling and production of sub-sea oil is, like any other industry on land and therefore for carrying out her trade she needs site area , finances , platforms for working and support services.

Fixed platforms working on site in territorial waters, pose no difficulty what-so-ever as these are considered as industrial sites on water and existing laws of the land are applicable to them. These laws can effectively deal with the platforms. However, the problem arises when the sites are on the continental shelf or in the exclusive economic zone , where both types are in use (i.e. fixed and mobile platforms ) and where the rights of a coastal state are conditional as defined in " The Law of The Sea " convention. .

### 6.3. Main Areas of Offshore Oil Activity

The main areas of offshore activity on continental shelf are technically as follows :-

- a) allocation of exploratory and oil production sites.
- b) suitability and safety of platforms.
- c) supporting services required on platforms.
- d) supply and support vessels needed for platforms.
- e) management for safe operation and safety measures.

a) allocation of exploratory and oil production site needs.:

- i) financially sound and reliable concern.
- ii) good programme for operational safety.
- iii) details of methods to be adopted in well drilling and in abandoning of wells.
- iv) details of equipments (such as casing and cementing) used for well drilling.
- v) details of proposed arrangements for prevention of blow-out ( B.O.P.) i.e. the uncontrolled escape of oil or gas as the case may be.

b) suitability and safety of platform structure:

- i) registration of platform.
- ii) a sound design to meet all environmental and other forces to which the installation may be subjected during its life.
- iii) use of appropriate material and construction techniques.
- iv) In the case of mobile platforms I.M.O.'s standards given in the M.O D.U. code can be used for guidance.
- v) use of approved and safe equipment and machinery.

- vi)proper structural fire protection.
  - vii)use of standard protection features for safety of personnel.
  - viii)adequate accomodation and crew facilities as per I.L.O. convention.
  - ix)use of established practice for occupational health and hazards (I.L.O. standard).
  - x) excess noise and vibration control(international standards)
  - xi)environmental pollution control as per I.M.O. conventions on Oil,Sewage and Garbage.
  - xii)collision prevention ( i.e. light and sound signals for ships and aircraft).
  - xiii)proper fire fighting system and life saving appliances.
- c)supporting services on platforms :
- i) a good two-way public address system for emergencies.
  - ii)a good communication system with shore installations and other platforms.
  - iii)a suitable and safe helipad for helicopter transport service.
  - iv)a good and safe platform for sea transport services.

d)supply and support vessels:-

These are purpose built ships and as such they can be treated as cargo ships for the purpose of hull,machinery,equipment surveys and certification under I.M.O. code on offshore supply vessels.

e)management for safe operation requirements :

- i) emergency procedure manuals and safe working practices.
- ii)provision of safe equipments and their maintenance.
- iii)use of safe materials.
- iv)the safety of the installation (safety zones).
- v) maintenance of associated records.
- vi)well trained and qualified persons in their respective fields and the safety procedures.
- vii)manning scale

#### 6.4.Regrouping of Main areas for Governmental Control

- A. licensing of site and it's interconnected areas (such as soundness and reliability of parties ,detailed operational programme ,details of methods to be employed in well drilling and in abandoning wells , details of equipments and materials,casing and cementing used for well drilling etc., details of arrangement for prevention of uncontrolled escape of oil or gas (B.O.P.)
  
- B. i)registration and it's associated areas(i.e.nationality of owner,method of registration,obligation of owners,mortgages etc.,)
  - ii)platform structures and related areas during construction and service (i.e. design and suitability ,construction techniques and materials'testing,structural fire protection protection features for personnel's safety ,design of heli-pad structural support , details of machinery and other



equipments for example derricks for picking up stores and materials from supply vessels or used with drilling units etc., detail of crew's facilities and accomodation and standard of noise and vibration level in working and sleeping areas ,occupational health and hazard preventive practices, safety equipment plans i.e.L.S.A. & F.F.A., emergency procedures ,rescue of personnel and manuals for use in emergency.

C. i)medical facilities ( such as first-aid room / sick bay arrangements,drugs,medicines,medical instruments,stretchers etc.)

ii)storage rooms for food,galley,mess and laundry etc.

D. communication system (i.e. radio telephony and telegraphy, location of radio communication antennae and rooms,assignment of frequency for the helicopter beacon,intercom system etc.)

E. helideck and it's associated areas (such as distances to and the height of obstacles surrounding the helipad, strength and specifications of materials ,dimensions of scantlings and supporting members of deck etc..

F. if any radio-active material is used on the platform then the storage facilities and the use of it , will be an added area to be considered.

G. electrical installation which comprises of main and emer-

gency generating sets ,transformers,converters,accumulation batteries ,main and emergency switch boards ,large motors (i.e.rotary motors,draw work motors & mud pump motors etc.)

H. pressure vessels of all kinds.

I. collision and safety zone of 500 metres around the structure and it's preventive measures.

J. Prevention of environmental pollution ( i.e. by oil,sewage, garbage etc.)

K. casualty insvestigation.

Existing government agencies which can deal with various groups stated above are given below:-

- 1.Petroleum Ministry - group "A" and group "B"(fixed platform)
- 2.Shipping Ministry - group "B"(mobile platforms),groups-"I", "J" & "K".
- 3.Health Ministry - group "C".
- 4.Communication Ministry - group "D".
- 5.Civil Aviation Ministry - group "E".
- 6.Department of Atomic Energy - group "F".
- 7.Electricity Board - group "G".
- 8.Boiler Inspectorate & Explosive Directorate - group "H".

Since,all these above agencies are independent of one another, oil industry or for that purpose any offshore industry has to

go from one agency to another ,to satisfy their requirements. Co-ordinating inspection visits before starting the actual activity ,is a tedious job ,as one who has even little experience in dealing with government offices can easily visualize it.In order that the industry should not run around unnecessarily from door to door of one Govt. agency to another ,it is proposed that only one of the government agencies stated above should be made responsible to co-ordinate with other agencies.

## VII CONTROL SYSTEM IN U.K. AND NORWAY

Although every nation would deal with this problem, in a manner most suitable to them, the controlling method used by two leading nations (i.e. U.K. and Norway) in dealing with offshore oil production is given as follows:-

### 7.1. United Kingdom Control System

In the " United Kingdom " the responsibility for all offshore safety is contained within one government agency, namely, Department of Energy (15&16). This enables the oil industry to deal with one department only and also the department can then be staffed to enable specialist expertise to be provided rather than relying on " part time " and " generalist " views. Further, all loop holes in the statutory control could be plugged as far as practicable. The department does however consult other government bodies / departments and other organizations who have particular expertise that may be useful in offshore safety.

In the U.K. system, the department of Energy is a certifying authority for offshore installations, but it is not the intention of the Govt. that a large organization should be set-up within the department to carry out all technical appraisals required under the certification scheme, when competent bodies of experts already exist in the field. Hence, the Government has appointed other departments and organizations as certifying authorities to act on behalf of the department of Energy. How-

ever ,the department maintains a reasonable control over the actions of all these nominated / appointed certifying authorities and is the final authority in case of a dispute that may arise between an owner and a certifying body.

## 7.2.Norwegian Control System

In Norway ,initially the Petroleum directorate was the main organ ,similar to the U.K. system ,for both fixed and mobile platforms ,but at a later date,the Norwegian Maritime Directorate was appointed as the main organ for safety and control of "Mobile Offshore Platforms".However,the other government agencies were not totally absolved of their responsibilities. At present an owner applies and submits all the relevant drawings in triplicate to the Maritime Directorate ,who in turn transmits the same to the respective certifying authorities for their approval,such as :-

- 1.Petroleum Directorate.
- 2.The Civil Aviation Administration.
- 3.The Telecommunication Administration.
- 4.The Directorate For Seamen.
- 5.The Directorate Of Public Health.
- 6.The Water Resources And Electricity Board.
- 7.The State Institute Of Radiation Hygiene.
- 8.The National Inspectorate Of Explosives And Flammables.

On receipt of approval from all the agencies and the approved societies ,including it's own ,the Maritime Directorate then

issues a "General Approval" to the platform. This does not allow the owner to start up his operations on site or location. The owner still needs a drilling / production permit which is issued by The Petroleum Directorate after evaluation of , among other things, the drilling/production programme etc..

Control functions of the respective control institutions in the Norwegian system briefly comprise of :-

#### The Norwegian Maritime Directorate

1. construction and strength.
2. stability.
3. accomodation.
4. fire extinguishing.
5. fire protection.
6. emergency power sources.
7. life saving appliances.
8. nautical equipments.
9. anchor bouys.
10. alarm instructions, musters, drills etc.,
11. metrological data, environmental data etc.,
12. helicopter deck, structural characteristics and fire fighting system.
13. general labour inspection , including control of lifts, cranes , loading gear, pressure air plants , ladders , protection equipment, working routines etc..

#### The Norwegian Petroleum Directorate

1. technical side of drilling equipments and their installations ,including the operation of same.
2. drilling process.
3. evaluation of the structure of organization from a drilling point of view (Technically).
4. control of working safety and safety precautions on the drill floor and in derrick operations.
5. contingency plans for accidents and cases of emergency.
6. diving ,including control of divers ,diving equipment and diving operations.

#### The Civil Aviation Administration

1. helicopter deck ,including positioning ,construction and equipment.

#### The Norwegian Telecommunications Administration

1. radio station with appliances and equipment.
2. the positioning of the radio station.
3. portable radio and radio telephony equipment.
4. other telecommunication systems.
5. assignment of call signs for foreign drilling units and frequency for radio beacons and frequency for communication with helicopters.

#### The Directorate for Seamen

- 1.organized protection work.
- 2.list of the persons on board.

#### The Directorate of Public Health

- 1.hospital ward with equipment.
- 2.first-aid resuscitation equipment.
- 3.hygienic conditions.
- 4.medicines.
- 5.radiography of personnel.
- 6.first-aid equipment etc..
- 7.arrangement with a doctor,including a doctor for divers.
- 8.qualifications of the personnel in respect of first-aid.

#### The Norwegian Water Resources And Electricity Board

- 1.electrical installations.
- 2.classification of areas with regard to danger of explosion, zoning ,classification/stipulation of zones and ventilation, electrical installations and equipments in dangerous areas.

#### The State Institute Of Radiation Hygiene

- 1.the transportation ,storage and use of radio active equipments.

#### The National Inspectorate Of Explosives And Flammables

- 1.the storage and use of explosives.



Both the U.K. and Norwegian systems are well established and either one could be adopted ,but as stated earlier offshore operations involve both industrial as well as marine operations so neither of them offers a perfect solution.The U.K. system considers that offshore activities are industrial activities on a site on the continental shelf and not a marine activity in it's true sense ,hence ,it's legislation empowers the department of Energy to be responsible for all aspects of control of safety.

### 7.3.Pros and Cons of U.K. & Norwegian Systems

#### 7.3.1.Control System In United Kingdom

The advantages of the system are that an owner has to deal with one office only for all his needs i.e. for allocation of site ,permission for operation,information on new requirements and on latest products and techniques in connection with offshore operation and also for developmental assistance etc..

The disadvantages of the system are that owner has to go from door to door to all approved / recognised certifying authorities,first to find their respective requirements and then to comply with the requirements and to satisfy them for approval of new construction of platforms,2)he has to apply and arrange for inspection of each certifying authority during construction and for regular inspection during operation in order to maintain valid certificates ,3)owner cannot deal with any one

department for all his obligations ,4)if his mobile platform operating on U.K. continental shelf ,get an employment in another country's continental shelf then the owner has a problem of meeting flag control conditions as his platform is registered with department of Energy.The owner has to again get his platform re-registered with Department of Trade ( marine division),who are responsible for flag control.This involves duplication of registration formalities which may in turn result in loss of time and money.And finally the system is a bit complicated and cumbersome to owners.

#### 7.3.2.Control System In Norway

The advantages of the system can be summerised as under:-

1. Owner has a clear picture of the office he should contact for fixed platforms and for mobile platforms and accordingly he gets all directives from one office only.
2. In case of change of employment for his mobile platforms there is no duplication of registration formalities as in the case of U.K. system.The platform can proceed to the new site as long as it is in possession of valid certificates.
3. Owner is free from having to contact relevant authorities which are involved in his operation ,as the department does all the co-ordination work.

There are only two note worthy disadvantages in the system, firstly owner has to maintain two separate identities in case

he owns both types of platforms, that is fixed and mobile type  
and secondly he still has to go to Petroleum Directorate for  
site allocation and permit to start his activity on site.

## VIII PROPOSED LEGISLATION

Like in any other nation ,in India also the co-operation and co-ordination of the two main ministries i.e. Ministry Of Petroleum and Ministry Of Shipping is very essential and at the same time very important in order that offshore activity can function smoothly . Whenever any site is to be allotted, whether it is in the sea lane or not ,Ministry Of Shipping's consent must be sought so that shipping activities in and around the site areas could be effectively controlled without causing any subsequent problems , which may or may not constitute costs.It is therefore recommended that for Indian environment the best system of control would be as under :-

### 1.Site Allocation

Ministry Of Petroleum should obtain a "NO OBJECTION" clearance from Ministry Of Shipping prior to issuing license or permission for site or sites and thereafter the Ministry should control all relevant operations on these locations.

### 2.Registration of platforms

- i) Fixed platforms - all work pertaining to this type of platform should be the responsibility of petroleum ministry.However,fire-protection,life saving appliances,pollution control,safety zones around platforms etc.,should be controlled with the co-operation and co-ordination of shipping ministry.

ii) Mobile platforms - all work connected with this type of platform should be the responsibility of shipping ministry. However, drilling and production equipment and their operation should be controlled with the co-operation and co-ordination of petroleum ministry, which is the only competent body in the country for new constructions and platforms working on Indian continental shelf or in exclusive economic zone.

### 3. Obligation of Other Agencies

All other agencies should extend their fullest co-operation and advise whenever contacted by these two ministries in their respective fields for new constructions or for routine inspections or renewal of certificates. Any new regulations in their respective areas should be promptly intimated to these main ministries for inclusion in the rules.

A separate and new Offshore Act should be passed as per U.K. practice, to control the safe operation and safety of the vessels / platforms and persons engaged in these activities, which may comprise of:-

- i) Declaration of agency / ministry / department that will be responsible and its scope of responsibility under the Act.
- ii) Agency/Ministry/department to have vested authority under the Act:-

- to issue license for site for drilling and production;
- to register fixed platforms ,procedures and methods of registration and related matter such as transfer of registry,nationality of owner,mortgages etc.;
- to register mobile platforms ,procedures of registration and it's related functions,similar to the registration of ships under Merchant Shipping Act;
- to delegate work on behalf of government to other governmental bodies and to other organizations such as classification societies ,who have expertise in such activities;
- to seek assistance or expertise from abroad;
- to relax the requirements in specific and exceptional cases;
- to make rules and organization of administrative bodies for contingency;
- to investigate into casualties;

iii)and to make rules:-

- for safe operation,abandoning of sites and safety of platforms;
- for safety zone around platform structures under the international convention on "The Law Of The Sea";
- for construction of platforms/vessels,machinery and equipments for safety of vessels/platforms or personnel based on international conventions,resolutions ,codes and international standard practices;
- for control of marine pollutions based on I.M.O.'s MARPOL, conventions on Oil,Sewage and Garbage;
- for stability ,load lines and tonnage measurements under

- guide lines of I.M.O. codes,conventions and resolutions;
- for prevention of collision of ships and aircraft;
  - for control of Noise and Vibration ,Occupational safety health hazards and welfare of persons engaged in these operations based on I.L.O. conventions;
  - for health and hygiene;
  - for communication systems (i.e.radio telephony,radio telegraphy,satellite communications etc.);
  - for safe diving including control of divers ,diving equipment and diving operations.
  - for owner's obligations ( i.e.upkeep of records of all the activities and account of personnel including accidents, major or minor and submission of same for inspection on request by visiting authorities.);
  - for minimum safe manning;
  - for working hours of personnel;
  - for qualification and certification of employees on board platforms/vessels;
  - for age,qualification and . experience at the time of entry into service as a departmental surveyor/inspector ,who in course of his natural duty ,shall carry-out statutory survey/inspection of these vessels/platforms on request of owner/master or platform manager even when these are at site (i.e.in E.E.Z. or on continental shelf ).

## IX CONCLUSION

The marine industry has been in a process of evolution since the beginning of time and the development of the offshore industry is a part of this process. It is important to note that established ship's rules were initially used worldwide but it soon became evident that new ones would be necessary due to the functions, geometrical features and dynamic responses of ships and offshore mobile units which are very different. Therefore the criteria used for stability of conventional ships cannot be applied to them (offshore vessels)

The proposed structure of legislation will enable the responsible office entrusted to make rules, to deal with the peculiar problems created by these novel installations, structural designs and their operations. However, rules alone cannot provide immunity to the problems, but will be able to reduce the occurrence of accidents if not complete elimination and thus will be able to improve the overall safety control system.

Surveys and inspections under the rules will guarantee satisfactory equipment, loading, manning and personnel's competence as well as general safety standards. One cannot expect an owner to discharge his duty dispassionately due to his vested interest. The recent disaster / catastrophe caused at Bhopal by M/S "Union Carbide" is a living example and an eye opener not only to India but also to the entire world. A nation should not rely entirely on the big or small industry / organization for safety



which is their own internal safety organization.

Of course ,additional safety features would require additional expenditure and so is the case with the training of personnel. It will be difficult at times to define rigorous standards and criteria of safety or to relate these closely to environmental conditions ,operational competence and practice.Experience has shown that both on conventional ships and on offshore units, that until a stage is reached where the entire crew (i.e. officers and members of crew / workers) of these units is well trained and highly motivated towards safety,accidents may continue to happen regardless of safety improvements in design and national regulations.This does not necessarily mean that we should not have regulations.The proposed legislation will strengthen the hands of the administration and their staff for effective control ,implementation of international standards and a safer working environment.This would in turn reduce accidents and losses ,thereby benifitting the offshore industry, personnel aboard offshore vessels and platforms,the marine environment and would also improve the productivity and efficiency of offshore operations.

## APPENDIX I

The Conventional shipping fleet consist of the following types of vessel:-

1. Passenger . . . . i) international trade.. (a) passenger ship  
ships (b) cruise ship  
ii) domestic and short (a) passenger ferry  
international trade. (b) car cum passenger  
ferry.
  
2. Cargo ships.. i) international trade. (a) general cargo  
(b) bulk cargo  
(c) O.B.O.  
(d) RORO  
(e) container ship  
(f) LASH ship  
(g) coal carriers  
(h) grain carriers  
ii) on coastal trade... (a) general cargo  
(b) bulk cargo  
(c) coal carriers  
(d) grain carriers  
(e) container (feeder)
  
3. Tankers i) both of inter- (a) crude oil carriers  
national and coastal (b) product carriers.  
trade . (c) chemical carriers.  
(d) L.N.G. carriers

(e)L.P.G. carriers

APPENDIX II

However, precise figures were not published for the accidents in U.K. but the unit cost used in the estimate are given in table VI below:-

Table VI

Fatalities.....	3000.00 Pounds.
Group I injury (more than 4 weeks off work)....	1000.00 Pounds.
Group II&III injury(between 3to28 days off work)	500.00 Pounds.
Non-reportable small accidents.....	10.00 Pounds.
Material damage-non injury accidents.....	10.00 Pounds.

However ,better estimates could be obtained from two sets of data (i.e. from the data published by department of Health and Social Security U.K.and H.M. Factory Inspectorate U.K.,details of which are given in Robin's report 1972) ,given in table VII below:-

Table VII

A. National resource costs

Events	Total Nos. accidents	cost in M. Pounds.
Fatalities.....	1918.....	20.2
Industrial accidents lost output....	841680.....	84.5
Medical and hospital costs.....		12.4
Damage and administration.....		42.1
Prescribed diseases.....		3.7
Long term incapacity.....		8.1
Non-reportable accidents.....		37.9
		<u>Sub.Total- 208.9</u>
 <u>B. Subjective Costs</u>		 <u>M. Pounds</u>
Fatalities.....		9.59
Serious injury.....		42.08
Slight injury.....		77.75
		Sub.Total 129.42
Total resource plus subjective costs.....		338.30

APPENDIX III

The breakdown costs of accidents In United States Of America as reported in 1965 ,are given below in table VIII (these include accidents in home, on the roads and at work):-

Table VIII

	Millions U.S.\$
Accidental injuries.....	10700.00
Property destroyed by fire.....	1455.00
Property damaged in motor vehicle accidents.....	3100.00
Property destroyed and production lost in work injury accidents.....	2800.00
	total....18055.00

The cost of accidental injuries excluding material damage was around U.S. dollars 1100.00 millions made up as given in table IX below:-

Table IX

Costs	Work	Home	Motor	Public non	Total
			Vehicle	motor vehicle	in M.\$.
Wages lost.....	1400....	850....	2400.....	850.....	5500
Medical expenses..	650....	450....	550.....	250.....	1900
Overhead costs					
of insurance.....	750....	10....	2850.....	10.....	3600
sub total.....	2800...	1300...	5800.....	1100.....	11000
sub total as %					
of grand total...	25.5...	11.8....	52.7.....	10.0.....	100.0

## REFERENCES

1. "Development of the modern semi-submersible drilling unit" by T.V.Rodnight, RINA '83.
2. "Taps-Turret Anchored Production System" ,the Naval Architect Mazine April '85.
3. "Design created to support Alaskan offshore exploration", Offshore June '85.
4. "Vasudhara" by Oil and Natural Gas Commission Of India, '85.
5. "Fewer Indian Opportunities For Foreign Support Vessel Owners" by Terry Macallster, energy reporter in Lloyds's List 2nd Sept. '85.
6. "Offshore Technology conference Houston" ,a coverage by Ben Laurance.
7. "Offshore In '84", marine engineering/log April '85.
8. "Indian Marine Technology", a report by Glyn Ford, No.2 marine policy April 1983.
9. "Future Semi-Submersible Drilling Units" ,by D.S.Hammet, RINA '83.
10. "Report on the loss of the semi-submersible drilling rig OCEAN RANGER" by Royal Commission of Canada 1984, page viii.
11. "The I.L.O. And Small Business", an article in working environment '85.
12. "Industrial Hazard And Safety Hand Book", by Ralph King John Magid (pages 21 to 26)
13. "The Law Of Sea" ,M/S. Croom Helm London & Canberra, st.Martin's press New York.
14. "The Law Of Sea", hand-outs of professor Dr.Edgar Gold.
15. "Government Regulatory Control Offshore ,The U.K. Approach"



by J.R.Petrie RINA '83.

16."Safety Controls Under The Mineral Workings ( Offshore Installations) Act 1971",by W.R.Street,RINA.'74.