

MODELING DUST MOVEMENT IN A HOSPITAL  
BY USING SPACE SYNTAX ACCESS DIAGRAMMING

A Thesis

by

CHENG GUO

Submitted to the Office of Graduate and Professional Studies of  
Texas A&M University  
in partial fulfillment of the requirements for the degree of

MASTER OF SCIENCE

Chair of Committee,	John M. Nichols
Co-Chair of Committee,	Kevin T. Glowacki
Committee Member,	Leslie H. Feigenbaum
Head of Department,	Joe P. Horlen

May 2016

Major Subject: Construction Management

Copyright 2016 Cheng Guo

## ABSTRACT

In the United States of America, a significant number of immune compromised patients die in hospitals each year due to nosocomial infection. In order to reduce the risk from fungal microorganisms, it is important to analyze the dust movement throughout hospitals.

In this thesis, I will apply a method of architectural diagramming called access analysis to provide insights on how dust may be transmitted throughout buildings, in particular via doorways and through the HVAC system. Access analysis is derived from Space Syntax methods of understanding the spatial configuration of a building and how human beings move through connected space. The first step in conducting this research is to create 3D Revit model of a hypothetical hospital and design the HVAC system for that building. The writer also needed to generate access diagrams using a Revit add-in and other software in order to compare all potential routes of dust movement from the exterior to a certain space within the building.

The paper provides a working example of a hospital and creates an access graph and its subsequent analysis. The paper also discusses the potential application of this approach to provide a comprehensive model for the analysis of dust movement in a hospital.

## DEDICATION

I would like dedicate this dissertation to my parents, Shaohua Guo and Li Wang, for all the financial support and encouragement they have given to me throughout these years of my study abroad. Best wishes to them.

## ACKNOWLEDGEMENTS

I would like to thank my committee chair, Dr. Nichols, my co-chair, Dr. Glowacki, and committee member, Mr. Feigenbaum, for their guidance and support of this research.

## NOMENCLATURE

AHU	Air Handling Unit. A device used to regulate and circulate air as part of a heating, ventilating, and air-conditioning (HVAC) system
ASHRAE	American Society of Heating, Refrigerating, and Air-Conditioning Engineers
Aspergillosis	Aspergillosis is the name given to a wide variety of diseases caused by infection by fungi of the genus <i>Aspergillus</i>
<i>Aspergillus</i>	<i>Aspergillus</i> is a genus consisting of a few hundred mold species found in various climates worldwide
Asepsis Ward	The patient room which is being free from disease-producing microorganisms
Connectivity	The method measures the number of immediate neighbors that are directly connected to a space
Convex Space	A space where no line between any two of its points crosses the perimeter. A concave space has to be divided into the least possible number of convex spaces
HVAC	Heating, Ventilation, Air-Conditioning

Infection Control	Infection control is the discipline concerned with preventing nosocomial or healthcare-associated infection
Justified Access Diagram	An access diagram restructured so that a specific space is placed at the bottom, “the root space”. All spaces one syntactic step away from root space are put on the first level above, all spaces two spaces away on the second level, and so on
Nosocomial infection	The infection originating or taking place in a hospital, acquired in a hospital, especially in reference to an infection
Space Syntax	The term space syntax encompasses a set of theories and techniques for the analysis of spatial configurations related to movement and activities within a building or urban environment

## TABLE OF CONTENTS

	Page
ABSTRACT .....	ii
DEDICATION .....	iii
ACKNOWLEDGEMENTS .....	iv
NOMENCLATURE.....	v
TABLE OF CONTENTS .....	vii
LIST OF FIGURES.....	ix
LIST OF TABLES .....	xi
CHAPTER I INTRODUCTION .....	1
Background of the Study.....	1
Problem Statement .....	2
Research Objectives .....	2
Research Hypothesis .....	3
Research Limitations.....	3
Research Assumptions .....	3
Significance of Study .....	4
CHAPTER II LITERATURE REVIEW .....	5
Introduction .....	5
The Risk of Aspergillus in Hospitals .....	7
Guidelines for Infection Control in Healthcare Facilities .....	8
A Brief Introduction to Space Syntax and Its Applications .....	9
Contaminant Transport Model .....	14
Guideline of HVAC System in Hospital .....	15
FTT Analysis of Building Differential Pressure .....	20
Conclusion.....	21
CHAPTER III METHODOLOGY.....	22
Introduction .....	22
Design a Typical Hospital .....	22
Design HVAC System in Hospital.....	23
Justified Access Diagram .....	33

CHAPTER IV RESULTS .....	38
HVAC System Design .....	38
Access Diagram of Hospital.....	43
CHAPTER V CONCLUSION .....	54
REFERENCES.....	56



## LIST OF FIGURES

	Page
Figure 1. Diagram of a building ventilation system from ASHRAE (2007) .....	9
Figure 2. The plan of a hospital floor after Bafna (2003) .....	10
Figure 3. The access graph of a hospital floor from Bafna (2003) .....	11
Figure 4. The patient flow process in the hospital from Khan (2012) .....	12
Figure 5. A floor plan of a hospital from Khan (2012) .....	13
Figure 6. The J-Graph of the plan above and its depth from Khan (2012) .....	13
Figure 7. HVAC design parameters regarding infection control (Geshwiler, Howard et al. 2003) .....	19
Figure 8. FFT analysis of differential pressure at a room in Langford A (Bhatt 2016) ...	21
Figure 9. The 3D view of the hospital.....	23
Figure 10. The psychometric chart from Pita and Stevenson (1998).....	31
Figure 11. A convex space .....	34
Figure 12. A concave space.....	34
Figure 13. The floor plan of 1 <sup>st</sup> floor.....	35
Figure 14. The floor plan of 2 <sup>nd</sup> floor.....	36
Figure 15. HVAC system on the first floor .....	41
Figure 16. HVAC system on the second floor .....	42
Figure 17. HVAC system, 3D view .....	43
Figure 18. Connective study of the hospital.....	44
Figure 19. Justified access diagram of the hospital.....	45
Figure 20. The connectivity study of the HVAC system in the hospital .....	47
Figure 21. Justified access diagram of the HVAC system in the hospital .....	48

Figure 22. How dust enters Recovery Room #3 .....51

## LIST OF TABLES

	Page
Table 1. Minimum filter efficiency in different space in healthcare facilities from (Geshwiler, Howard et al. 2003).....	17
Table 2. MERV and filter efficiency according to particle size from (Geshwiler, Howard et al. 2003) .....	18
Table 3. Duct size selection.....	29
Table 4. Hospital room CFM calculation.....	39
Table 5. Summary of all possible routes to recovery room #3.....	50
Table 6. Summaries of dust sources to Room 25 .....	53

# CHAPTER I

## INTRODUCTION

### BACKGROUND OF THE STUDY

The risk of fungal microorganisms, like *Aspergillus*, as one of the major live component in dust, is becoming an increasingly dangerous and challenging threat to the human community. The people who are highest at risk are those who are immune compromised, especially those in some very high-risk settings, such as hospitals or nursing homes. This thesis aims to establish a model of dust movement occurring in a typical hospital setting using a type of architectural diagram called a justified access graph as part of an ongoing research effort into the movement of fungi from a benign to a deadly situation near an immune compromised patient.

Nosocomial infection of hospital facilities has become a significant factor in the death of patients, as noted by the CDC and others (Bassett 2013). Data released from U.S National Nosocomial Infection Surveillance System oaspines that each year up to two million people in North America contract a nosocomial infection in a hospital and around 100,000 patients die as a result (Malik, Arabzadeh et al. 2008). Infection outbreaks have been linked to hospital construction, facilities maintenance, and renovation, all of which disturb fungus spores from the soil and cause them to become airborne (Reboux, Gbaguidi-Haore et al. 2014). A goal of infection control is to minimize nosocomial infections and to ensure that patients or staffs in the hospital are protected from exposure to lethal microorganisms. The hospital itself provides an additional level of potential infection when compared to the home environment.

## PROBLEM STATEMENT

It is clear that Aspergillus and other fungi pose a significantly amount of risk to the immune compromised person in the hospital. Different methods exist for analyzing the movement of dust in a building. Fungus-bearing dust can enter a room from adjacent spaces, such as corridors. Dust can potentially move through ductwork in the air conditioning system. Dust can also leak through the openings in the building envelope, such as doors and windows. There is currently, however, a lack of the comparison of dust movement rates via different routes within a building with the result that no one knows truly knows the percentage of dust that moves along the different paths.

## RESEARCH OBJECTIVES

The primary research objective of this paper is to analyze dust movement in the health care facilities and to examine which type of transportation method contributes the greatest amount to the infection in the hospital. To achieve these research objectives, the following tasks steps have been included:

- Devise a systematic and intuitive diagram to analysis the dust movement rate through airflow within buildings.
- Create a 3D model using Revit based on CAD drawing, to analyze dust movement rate in an air conditioning system.
- Compare results from methods above to examine the major patterns of movement for dust in a healthcare facility.

## RESEARCH HYPOTHESIS

The research will test the validity of these following hypotheses:

- The movement rate for dust in air conditioning system is significantly higher than other transportation paths.
- Most of the dust in a healthcare facility come from the mechanical system of building when in operation.

## RESEARCH LIMITATIONS

The limitations of the study are:

- It is a self-designed and self-performed test, so there will probably result in some error in the analysis
- It is unknown that how many *Aspergillus* spores are needed for development infection

## RESEARCH ASSUMPTIONS

In this research, it is assumed that:

- The building sample in this research is a typical type of hospital; all mechanical systems in this hospital run functionally; and the method used in this sample is widely applicable to all similar circumstances.
- All the analysis and experiments will be conducted and completed independently; all data from the experiment will be examined to be valid before conducting the statistical analysis.

- The substance of dust that will be analyzed is of a correct size, type, and representation.
- The data from the experiment is independent of weather conditions, humidity, and temperature, and location, size of the hospital.

#### SIGNIFICANCE OF STUDY

This thesis seeks to understand the major transmission patterns for airborne dust within buildings. Additionally, this study seeks to compare different transmission patterns of dust. As healthcare facility construction and renovation become more common and necessary, construction-related nosocomial infection and risk of *Aspergillus* become more and more dangerous to humans in the building. Despite various researchers having introduced several different methods to control and eliminate nosocomial infection in buildings, these studies still seem to have relatively low levels of effectiveness and efficiency. In this way, the expected benefits of this research could bring a theoretical foundation for innovations in reducing infections in hospitals during construction and/or renovation. A decreased number of patients contacting construction-related nosocomial infection could be expected. The results and conclusions of this research will be public information and give scientists and engineers a better knowledge to control infection within hospitals.

## CHAPTER II

### LITERATURE REVIEW

#### INTRODUCTION

This literature review considers:

- Aspergillus as an infecting agent.
- Why hospitals are a sensitive place for controlling Aspergillus.
- Guidelines for environmental contamination control of health-care facilities and HVAC systems in hospitals.
- A brief introduction of space syntax theory and its application to architecture.
- Current methodologies and technologies to monitor, control, and remove fungus-related pollutants in health-care facilities.
- Several models used to analyze contaminant transport and movement in enclosed areas.

Bassett commenced a study into fungal infections in hospitals by looking at the utility of a barrier to prevent the movement of dust from a construction zone to a clean zone. Interestingly, Bassett showed that a simple plastic barrier made from the cheapest and simplest materials available in a commercial setting stopped the movement of all observable dust. Bassett developed a simple tool and test protocol to study this airflow problem.



Many offer the opinion, although limited measurements exist to show, that during construction the amount of dust in the hospital may significantly increase (Bassett 2013). The use of HEPA filters (Papadopoulos 2015) in air conditioning systems may assist in the removal of particulate, viral, and fungal matters, but the system may become contaminated and the contaminated air conditioning system may, therefore, transmit these microorganisms to the vulnerable populations. This act of contamination is a threat to the patients and has the potential to cause infections both to those with serious illnesses and injuries and to people who fail to understand and follow infection control procedures (Cheong and Phua 2006) (Sehulster, Chinn et al. 2003).

There are two ways for microorganisms to transmit through a building. Firstly, dust can transmit through the air conditioning and mechanical ventilation system (ACMV) (Sehulster, Chinn et al. 2003). Secondly, pollutants can leak through the connection of rooms, such as hallways, windows, and doors.

An ACMV system, a particularly critical element for hospitals, needs to protect against the airborne transport of contaminated air capable of damaging the human respiratory system. Various research groups have focused on the patterns of airflow and contaminant transport in the ACMV system and the pollutant distribution pattern through building components. Cheong and Phua (2005) examined the air conditioning and ventilation system of a hospital operating theater and found that the air supply and air distribution systems could be configured to reduce infection matter within the surgical field rather than in the entire room. This particular subject is still a field of much research worldwide. (Malik, Arabzadeh et al. 2008)

Construction-related nosocomial infections may be preventable with the proper approach, but studies that provide simple and uncomplicated analysis on how dust is transmitted from the exterior into the interior are limited. This study will introduce and explore a method based on the framework of space syntax theory to analysis dust movement in a hospital in order to reduce the transmission of construction-related infections. Infections follow a similar route to humans into hospitals if the HVAC system is well designed and difficult to penetrate.

#### THE RISK OF ASPERGILLUS IN HOSPITALS

Micheli first cataloged *Aspergillus* in 1729. It is a ubiquitous species that grows in the soil and on plants (Machida and Gomi 2010). Also, it can be found in dust and some foods. These fungi adapt easily to nearly all environments that contain moisture. During the phase of construction or maintenance of a hospital project, millions of spores that contain *Aspergillus* could transit through the healthcare facilities

People with depressed immune systems, such as those who contract an immunodeficiency virus or those taking immune suppression drugs, are the ones who at the greatest risk of contracting *Aspergillosis*. These patients will be settled in a special asepsis ward. However, most of them will also spend time outside the ward, such as in the Intensive Care Unit (ICU) or operating room (OR), which may greatly increase their probability of catching *Aspergillosis* if no effective infection control methods have been implemented at the hospital.

## GUIDELINES FOR INFECTION CONTROL IN HEALTHCARE FACILITIES

During construction and/or renovation activities in healthcare facilities, there will be an increase in the number of airborne *Aspergillus* spores (Reboux, Gbaguidi-Haore et al. 2014). Schulster and Chinn (2003) note that there are three primary topics to consider prior to any construction or renovation activity:

- The proper design and function of the new area.
- The evaluation of dangerous airborne fungi and chances for prevention.
- The development of methods to contain moisture or dirt during construction.

There are also various requirements of HVAC systems in healthcare facilities. The poor performance of the healthcare facility HVAC system, inappropriate installation, and decreased maintenance would all contribute to the spread of airborne fungus (ASHRAE. 1999).

Figure 1 shows a typical design of a ventilation system.

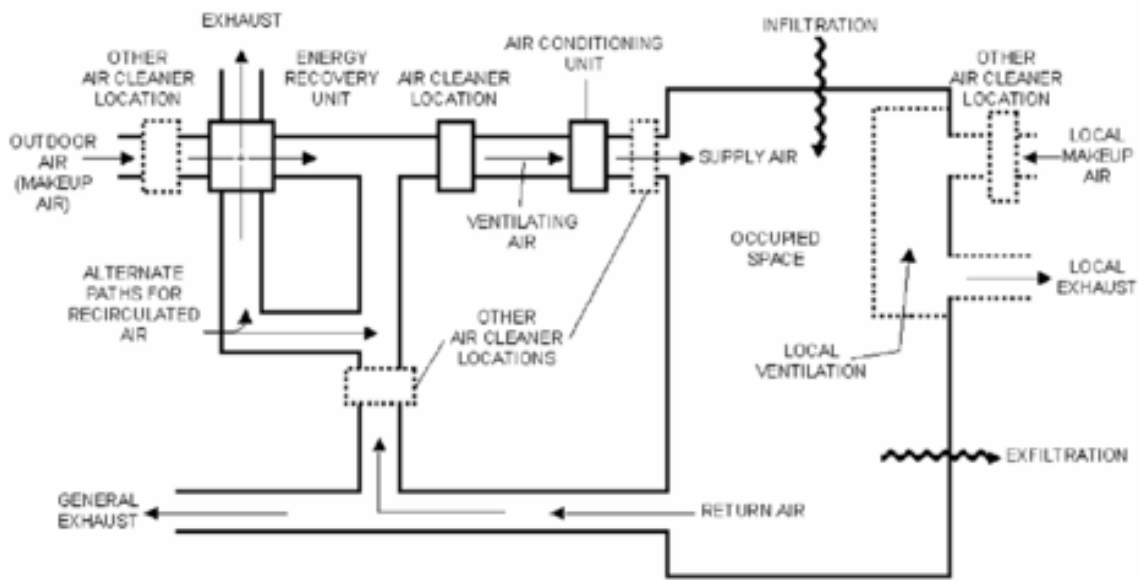

Figure 1. Diagram of a building ventilation system from ASHRAE (2007)

What this figure does not show is the alternative paths into the room for dust and fungi.

## A BRIEF INTRODUCTION TO SPACE SYNTAX AND ITS APPLICATIONS

The space syntax is described as the research program that investigates the relationship between human societies and space based on the perspective of the theory of the structure of inhabited space, such as buildings, settlements (Bafna 2003). In the recent decades, various researchers use space syntax to analysis not only the spatial organization but also socio-economics (Chiaradia, Hillier et al. 2009), safety issues (Raford and Ragland 2004), etc. The primary research object of space syntax analysis is configured space, it is typically in the form of building floor plan, independent of dimensioning, focusing solely in existing relationships among spaces. And in the analytical study of configured space, it is re-described focusing on its topology, which

means the sociologically relevant aspects of configured space could be represented at the level of topological description (Bafna 2003).

The justified access diagram is used to conduct a quantitative and qualitative analysis of spatial ordering of a floor plan by transforming the floor plan into a network diagram. It helps to understand special depth distribution from any location in the plan. In addition, it leads to a numerical analysis of access and travel frequency.

Figure 2 shows a basic floor plan of a hospital. The letter P represents corridor, the letter A and B represent patient room and letter X represents anteroom.

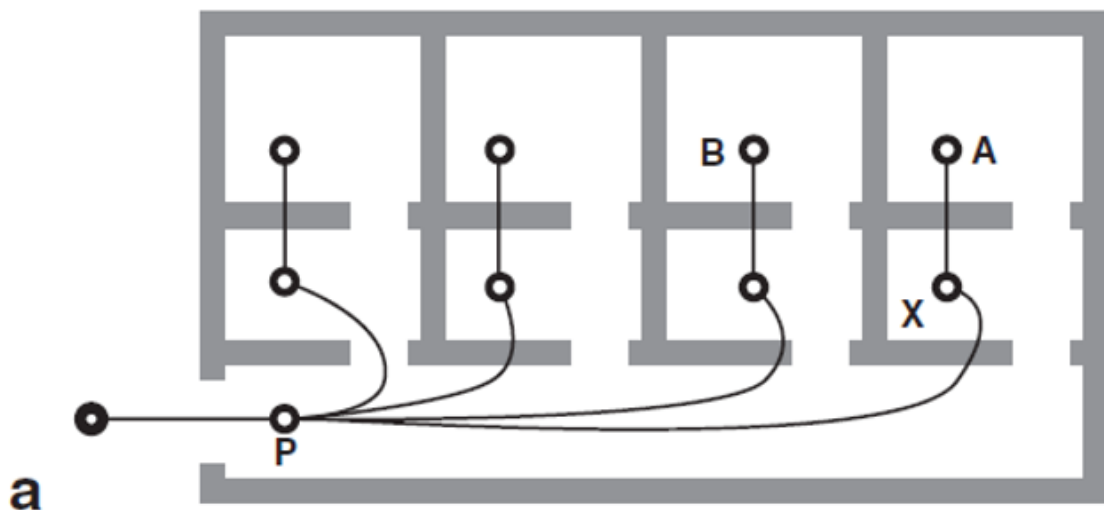

Figure 2. The plan of a hospital floor after Bafna (2003)

It is obvious that anteroom is directly accessible from the corridor and the patient room is accessible from corridor via anteroom. Based on the space syntax, we can draw each room as a node and direct access through ant two rooms as a link connecting their respective nodes.

The Figure 3 shows justified permeability graph of the plan. The higher positions within the hierarchy are shown in the upper level and lower positions are shown in lower level. The same hierarchy of rooms, even not directly linked, are shown at the same level.

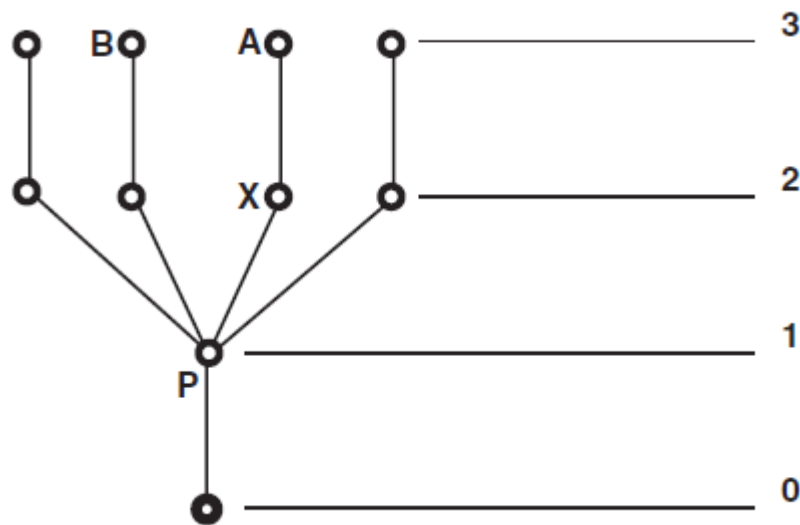
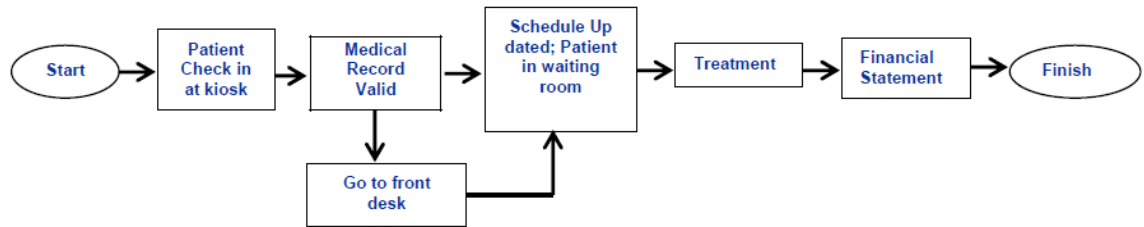

Figure 3. The access graph of a hospital floor from Bafna (2003)

The space syntax theory has board application in architecture and urban planning, especially in the design of healthcare facilities. Space syntax will help designers or planners generate a “descriptive anatomy” of space to describe and analyze the flow. The design of spatial layout for a hospital is challenging because its complex functions and organization structures.

Figure 4 shows the patient flow is the process by which patients are served through multiple types of care.



*Figure 4.* The patient flow process in the hospital from Khan (2012)

Generally, a better patient flow process could lead to better operational efficiency in healthcare facilities. In the hospital, from the entrance to exit, the patient need to pass through a set of conditions, activities, spaces that could be represented as a network related to system configurations and spatial relations. According to Hillier, hospital is a complex system that most spatial relations are predetermined by functional needs (Hillier and Hanson 1989). The space syntax could provide a framework to study healthcare environment.

The Figure 5 show a floor plan.

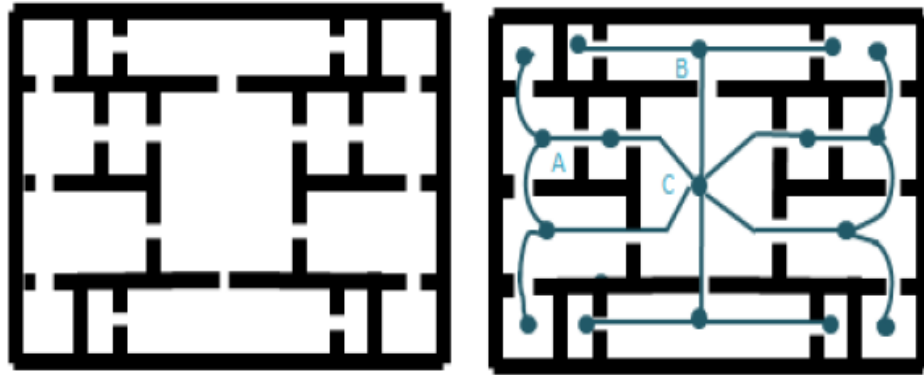

Figure 5. A floor plan of a hospital from Khan (2012)

Figure 6 shows its corresponding J-Graph.

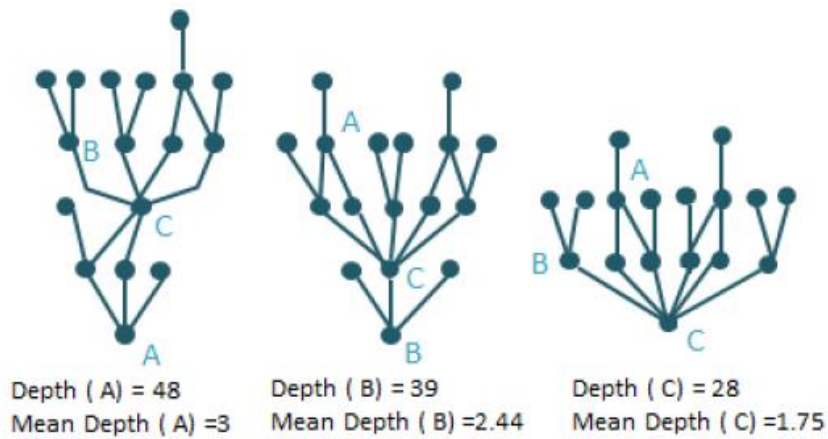

Figure 6. The J-Graph of the plan above and its depth from Khan (2012)

The different start point of J-Graph, from space A to C, would have different depth (Khan 2012). The term depth represents the least number of syntactic steps in a graph that are needed to reach one from the other (Klarqvist 1993). The researcher also found



people who entered space with lesser mean depth would have a better opportunities to explore the hospital in a fixed time (Haq 1999).

Kim and Lee (2010) find that justified diagram could be used to effectively simulate user's experience and movement for investigating alternative in the design of healthcare facilities. They found that deep-plan type design represents the most economical in terms of user cost analysis and better user productivity and security dead spots. Zadeh, Shepley et al. (2012) using the justified diagram in the design of acute care nursing and he found that J-Graph enables designers to reduce the movement sequence nurses undertake when accessing recourses and identify there the flow is disrupted by displaced functions.

#### CONTAMINANT TRANSPORT MODEL

To present the best approach for monitoring and controlling the airborne pollutant in health-care facilities, it is important to provide a tool for modeling airflow of microorganisms and contaminant transport. Dols (2001) describes CONTAMW, a computer software which provides multi-zone indoor quality and ventilation system analysis in the building. In his research, he describes that one of greatest application of CONTAMW using in the analyze contaminant transport: CONTAMV have the ability to analysis the mechanism of air flow, source and chemical reaction, the property of dust, that could make it useful to prevent contaminant-related building environment problems (Dols 2001).

CFD (Computational Fluid Dynamics) is another way to analyze room air distribution. Zhang and Chen (2007) present a new model called QR, which represent

quasi-reversibility equation and numerical scheme, could identify contaminant transport in buildings.

## GUIDELINE OF HVAC SYSTEM IN HOSPITAL

### *Basic Classification of Healthcare Facilities*

The healthcare facilities vary substantially in nature as well as the complexity of their provided service. Some classifications including practitioner's office, birthing centers, mental wellness centers, inpatient hospitals, and so on. Because the type of healthcare for this research is inpatient hospital, due to the basic condition and characteristic of this type of healthcare facilities, the author would focus mostly on several key functions of the HVAC systems. The next part will briefly introduce some main function of HVAC systems.

### *Healthcare HVAC System Functions*

The HVAC system in healthcare facilities performs several important roles in affecting environmental conditions such as temperature and humidity, infection control or hazard control to dilute and remove contaminant or toxin, building life safety that control smoke while on fire.

### *Comfort Conditioning*

To ensure patients and hospital staffs receive unique environmental requirements in healthcare facilities, we need to focus on how to improve comfort levels of each hospital by proper HVAC design. The environmental comfort is critical to everyone's wellbeing and productivity because it serve the role to facilitating healing and recovery of patients as well as the working productivity of hospital staffs. There are three major criteria to

determine environmental comfort in healthcare facilities: space temperature, relative humidity, and total air change rates.

### *Infection Control*

HAI, which is the abbreviation of Hospital-acquired infections, is now a significant topic in HVAC design. The following properties could be impacted by HVAC systems:

- Dilution.
- Air quality.
- Exposure time.
- Temperature.
- Humidity.
- Organism viability.

Generally, the severity of infection could be described:

$$Infection = \frac{Dose \times Site \times Virulence \times Time}{Level\ of\ Host\ Defense} \quad (1)$$

From the equation above, the severity of infection is determined by the exposure time, virulence and quantity of the microorganisms and locations. This equation could be used to design HVAC system to reduce HAI risks.

The Air filter could remove infectious organisms effectively. And the efficiency of air filter could be determined mostly by particle size. The smaller of particle size, the less efficiency of air filter it could be. In this research, the space designed is recovery rooms and the nurse station. The different type of space in healthcare facilities requires different attention in air filters.

According to ASHRAE standard 170-2008, shown in Table 1, the MERV, aka Minimum Efficiency Reporting Value of the filter bank in both recovery room and nurse station is 7.

Table 1.

*Minimum filter efficiency in different space in healthcare facilities from (Geshwiler, Howard et al. 2003)*

Space Designation (According to Function)	Filter Bank #1, MERV
Inpatient delivery and recovery spaces	7
Skilled nurses facilities	7

From the ASHRAE standard 52.5-2007, as shown in Table 2, the MERV 7 requires the air filter could remove 50% to 70% of the particles which particle size range from 3.0 to 10  $\mu\text{m}$ , and the MERV 7 cannot remove any particles of the size range from 0.3 to 3.0 $\mu\text{m}$ .

Table 2.

*MERV and filter efficiency according to particle size from (Geshwiler, Howard et al. 2003)*

MERV	0.3-1.0 $\mu\text{m}$	1.0-3.0 $\mu\text{m}$	3.0-10 $\mu\text{m}$
7	N/A	N/A	50% to 70%

Humidity is another important factor regarding infection control of HVAC design in healthcare facilities. In this research, the author uses RH, aka relative humidity, instead of absolute humidity. It would be dangerous in healthcare facilities if the RH is extremely low or extremely high, both of these extreme situations would cause the high risk of infections. In this way, for the purpose of HVAC design, the author set a maximum required RH of 60%, this value could both provide comfort condition to the person in the hospital and also reduce the hazard of mold growth.

Ultraviolet (UV) could effectively remove the virulence of microorganisms and reduce the infection rate, the stronger and longer of UV radiation, the more microorganisms could be eliminated.

Creating pressure relationship between inside and outside is another common way to eliminate the risk of infection. By pushing the pollutant air from the clean side to the dirty side, the microorganisms would be removed from the healthcare facilities. It is very

important to create a positive relative pressure to adjacent space in order to prevent potential hazards.

In summary, the following list shows the HVAC design parameters that could help to infection control in healthcare facilities.

The Figure 7 shows these parameters graphically.

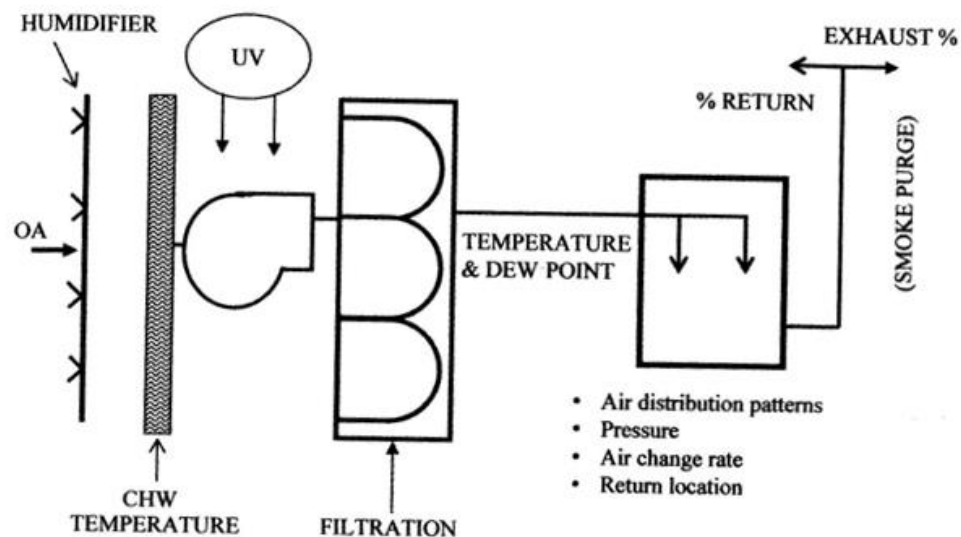

Figure 7. HVAC design parameters regarding infection control (Geshwiler, Howard et al. 2003)

These parameters include:

- Outdoor air quality, including natural ventilation.
- Type of filters.
- Humidity.
- UV radiation.
- Chilled water temperature.

- Supply air change rate.
- Air pressure.

#### FFT ANALYSIS OF BUILDING DIFFERENTIAL PRESSURE

Fast Fourier Transform (FFT) is a helpful mathematical tool to convert an original domain signal into a frequency domain and the other way. It is usually used when a person needs to compute a DFT matrix into sparse factors. (Van Loan 1992)

According to K. Bhatt's research, he measured differential pressure at Room 107 in Langford A and conducted FFT analysis of the data.

The Figure 8 shows the results of the experiment. The X-axis represents time and the Y-axis represents differential pressure. As you can see, the differential pressure looked randomly at the beginning and looked as a cyclical pattern after. In addition, there is a noticeable first peak cycle from the 0.6 to 0.8s. And the second peak is received at 1.6 to 1.8s. The frequency is one second.

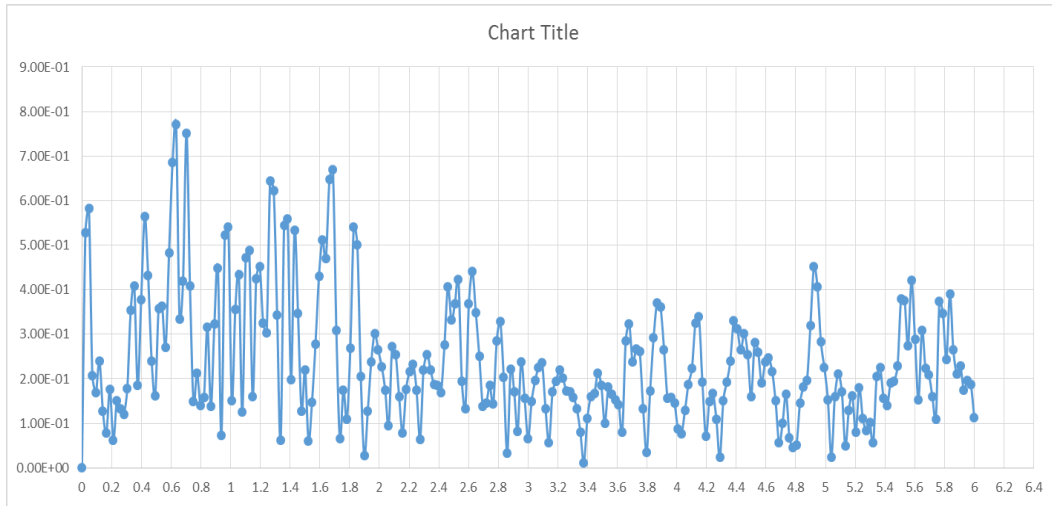

*Figure 8.* FFT analysis of differential pressure at a room in Langford A (Bhatt 2016)

Dust movement within the hospital is determined by air pressure differential between spaces, the Bhatt's research provides us the information how air pressure differential is ranged in a fixed time.

## CONCLUSION

This literature review clearly illustrates the current study of the dangerous of *Aspergillus*, the technology to identify and removal such organisms in the hospital and the theoretical framework of space syntax analysis. However, the further study and investigate about this topic is worthwhile.



## CHAPTER III

### METHODOLOGY

#### INTRODUCTION

This chapter outlines the methodology used in this research program, the main elements of methodology are:

- Design a typical hospital.
- Design the HVAC system for the hospital.
- Generate Justified Access Diagram.
- Analysis potential pathways for dust entering patient rooms.

#### DESIGN A TYPICAL HOSPITAL

The first step of this research is to design a hospital. A typical hospital should contain corridor, several recovery rooms, nurse station, windows, doors, walls, mechanical system and so on.

Figure 9 showing the 3D view of the hospital. The hypothetical hospital is a two stories building, the ceiling height of each floor is 8.5 ft., and the total height building is 17 ft. The floor area of the 1<sup>st</sup> floor is 7564 SF and 2<sup>nd</sup> floor is 8130 SF, and the gross area of this building is 15694 SF.

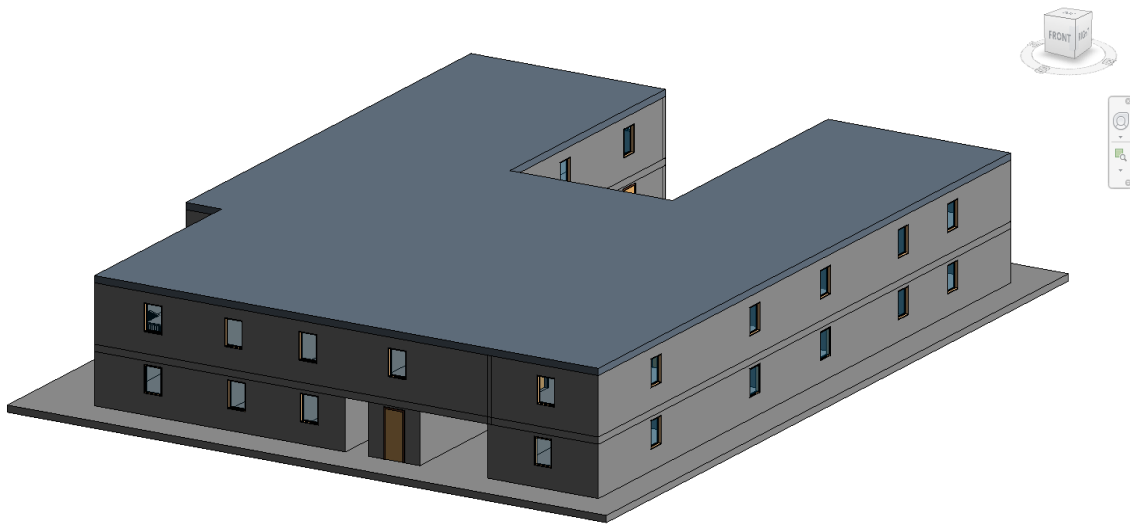

*Figure 9.* The 3D view of the hospital

## DESIGN HVAC SYSTEM IN HOSPITAL

The HVAC system in the hospital provides another way by which dust could be spread throughout the building. The design of HVAC system including air handling unit and distribution system, as well as special consideration for recovery rooms.

### *Air Handling and Distribution Systems*

#### Concept Design

Air handling and distribution systems provide various functions in the healthcare facilities, which including comfort conditioning, air quality maintaining, airborne infections reducing, odor controlling, smoke ventilation, etc. The design of air exchange rate, temperature, and humidity level and air filtration are very important in a hospital.

Due to the difference between healthcare facilities and another type of buildings, the designer needs to ensure sufficient space needed for the mechanical room, chase, and

above-ceiling components during the conceptual design phase. The list of consideration regarding system including:

- *Review the preliminary life safety plan.*
- *Identify areas with specialized air-handler requirements.* These are some areas in the hospital, such as operating rooms, procedure rooms, require additional air handler components to increase airflow or decrease room temperature. Because the subjects of this research are recovery room and nurse station in the hospital, there are no specialized air-handler requirements.
- *Consider optimal air-handling unit size.* The optimal air-handling unit size of a typical hospital is about 20000 to 40000 CFM (9438 to 18876L/s).
- *Determine airflow requirements for each airhandler zone.* This shows a typical room airflow summary for recovery room and the nurse station.
- *Consider system redundancy.*
- *Strategically locate mechanical rooms and chases.* Air-Handling Unit Component Design Considerations

The functions AHU provided regarding environmental comfort and ventilation including intake the outdoor air to make it meet ventilation air requirements, thermal conditioning, and moisture control, and filtration, remove pollutants. The design work of AHU unit mainly including:

- Outdoor air intake.
- Heating coil.
- Cooling coil.

- Supply fan.
- Humidifier.

The section describes the design of above components in detail.

The AHU casing is important to minimize water and dirt accumulation of an AHU unit and resist corrosion. The designers could consider foam-filled panel walls for AHU construction. Also, additional casing components are needed for enhancing ease of maintenance and service.

The location of outdoor air intake should also be considered in order to minimize the risks of potential contaminant sources, such as boilers, cooling towers, etc. According to ASHRAE Standard, the distance of 30 feet (9.1 m) is desired for the spacing between the outdoor air intake and some potential contaminate source. Moreover, outdoor air intake should be located a minimum of 8 feet (2.4 m) above grade in order to avoid intake of debris from the roof.

With the purpose of ensuring the outdoors air and recirculate air are mixed adequately in order to avoid the impingement of stratified air. The designer needs to design proper air mixing equipment to improve air stream mixing. Also, as stated before, a pre-filter of MERV (Minimum Efficiency Reporting Value) of 7 is required to be provided within downstream of the mixing box and upstream from heating or cooling coils. The purpose of this filter is to remove lint, dust or another large particle from the air stream. Heat recovery equipment is also desired for capturing some of the heat of exhaust air to precondition outdoor air. In this research, the author chose rotary heat exchangers to wheel to achieve this function.

There are several considerations regarding the heating coils.

- Accessible panels are required to enable maintenance person access into the entire face of coils.
- Coils must be constructed of noncorrosive metals.
- The location of air vent discharge and the direction of automatic and manual air vents should be considered so that water would not leak into AHU.

Moreover, some energy standard requires a significant reduction of fan power.

According to the relationship between chilled water velocity, air velocity, and air temperature. The temperature is positively correlated to air velocity and negative correlated to chilled water velocity. In this way, chose low-velocity coils could improve coil performance and reduce energy consumption. In this research, the author chose design velocity as 250 FPM (1.3 m/s) as the minimum velocity.

The exposure to subfreezing temperature may cause the burst coils or automatic unit shutdown. There is various factors contribute to these problems: inadequate air mixing, inadequate located and installed freeze stats, etc. Due to the long maintenance time of replacing a damaged coil, especially in some extreme environment. The designer needs to take some general freeze prevention considerations. In this research, the author design a preheat coil, which is located at the downstream from the pre-filter and before the cooling coil.

The function of cooling coils in the design of HVAC systems not only providing sensible cooling but also act as a dehumidifier. There are some generation considerations regarding cooling coil designation.

- The cooling coil must have a high heat transfer surface area consisting of at least six tubing rows with tightly space fins.
- There are six rows of the coil and 10 fins per inch.
- The downstream and upstream of the cooling coil should be accessible to a maintenance worker.
- The design coil velocity is 250 FPM (1.3m/s) in order to reduce energy consumption and improve coil performance.

The UV system is another important component of AHU. The function of UV is to cleanse cooling coils, drain pans, and some airstreams within ductworks.

There are so many types of fans in air handling unit, the major difference among them is blade configuration. When making selection of appropriate type of supply fan, the designer need to consider not only during operation process but also maintenance phase. In this research, the author selects centrifugal fans with plenum/plug.

Since the HVAC system has returned ducts, a return fan needs to create returned air pathway, but also used for smoke evacuation and smoke ventilation. Same as the design of supply fan, the designer should consider fan noise generation and ensure adaptable system effect and belt losses. In this research, I chose the same type of centrifugal fan as the supply fan,

Humidifiers are required in this research in order to maintain a minimum humidity of the occupied space. The inappropriate humidity in the healthcare facilities may cause the overgrowth of hazard microorganisms. There are certain considerations regarding the design of humidifiers.

- The type of humidifier. According to ASHRAE Standard 170-2008, the type of humidifiers for healthcare facilities should be steam injection type. The advantage of using this type is that steam is sterile so that it could eliminate the risk of bringing vital microorganism.
- Avoiding wetting of air handler or duct.
- The location of the humidifier. Consider placing the humidifier at the upstream of the cooling coil.
- Humidifier control. A humidifier could control by a supply air sensor so that the control sense could have a setpoint limit from 80% to 90% to prevent the oversaturation of the supply air.

Apart from the pre-filter, the final filtration is also required for the healthcare facilities. In this research, the author chose filtration level of MERV 14 for all hospital areas according to the FGI Guidelines. In addition, the design air velocity for healthcare facilities final filter should not exceed 500 FPM (2.5 m/s).

#### Ductwork

The proper design of duct system in healthcare facilities is important. There are several general consideration regarding ductwork design.

- Pressure losses.
- Pressure class.
- Fittings.
- Access. Must provide the access opening in the ducts for the system maintenance and inspection.

- Elbows. Try to use long-radius elbows to minimize pressure loss instead of using square elbows.
- Flexible ductworks. Limited use of flexible ductworks to minimize pressure loss. The maximum length of flexible ductworks is 5 to 6 ft. (1.5 to 1.8 m).

In this research, the author uses fully ducted return system because of the advantages of its sanitary characteristics. It could protect the airstream from direct exposure to potential plenum conditions such as accumulated dust, microorganisms, etc. The external insulation of ducts is preferred compare to internal insulated due to the reduced risk of infection and system static pressure lost. The size of ducts is determined by space's CFM.

Table 3 shows the conversion between airflow CFM and duct size. We can either choose round duct or rectangle duct.

Table 3.

*Duct size selection*

Airflow CFM	Supply or return duct size			
200	8" RD	OR	6" * 8"	
300	9" RD	OR	8" * 8"	
400	10" RD	OR	10" * 8"	
500	11" RD	OR	14" * 8"	10" * 10"



Fire damper is passive fire protection products in the HVAC systems. The selection of fire damper is based on the considerations of sufficient clearance, access for testing and static pressure drop. In this research, the author chose Type A fire damper. The typical installation of this type of fire dampers is in a low-pressure system.

#### Room Air Distribution

In healthcare facilities, the room airflow rate must be sufficient in order to meet heating or cooling loads, air exchange rate and makeup air requirement.

#### Dehumidification

The water vapor condenses if the dew point of supply air to the room below the room dew point temperature, this is a theory of de-humidification. In the research, the designed condition of the recovery room and nurse station is 70 – 75 F (21.1 C to 23.9 C) temperature, and the relative humidity is 50% to 60%.

The Figure 10 shows psychometric chart. The corresponding dew point of the condition above is 50 to 55 F, since the supply air temperature should lower than the dew point, then the supply air temperature should be 50 – 55 F (10.0 C to 12.8 C).

**PSYCHROMETRIC  
CHART**  
Normal Temperature  
I-P Units  
**SEA LEVEL**  
BAROMETRIC PRESSURE: 29.921 in. HG

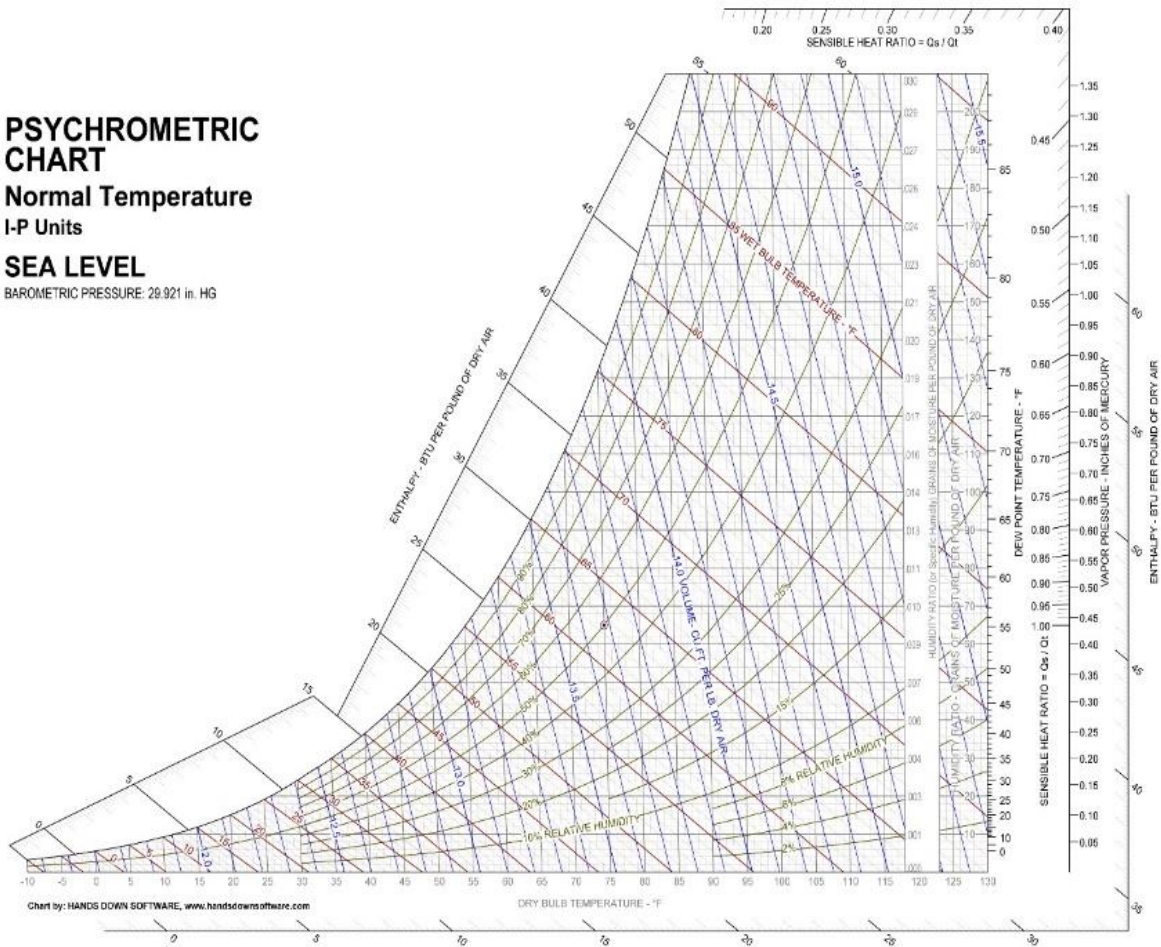

Figure 10. The psychrometric chart from Pita and Stevenson (1998)

*Room Design*

Introduction

The rooms in healthcare facilities need special design consideration because of infection control issues. These part of research presents practice suggestion about how to achieve the requirements.

## Room Pressurization

One common method of room design in healthcare facilities is room pressurization. Many spaces in healthcare require maintenance of a pressure difference relative to adjacent spaces. Measuring air pressure difference between room and corridor could prove that all air flow in one direction. However, there are some other factors that allow air to flow despite air pressure difference, such as opening and closing doors or windows. The most significant factor that determines the amount of airflow from a room to a corridor is the airflow volume differential.

In order to maintain the desired pressurization, the designer needs to provide a tight envelope within rooms. For example, opening such as electrical outlets should be sealed. In addition, air could flow from one space to another via cracks or gaps in walls, ceilings, floors and so on. The sum of these areas is called leakage area.

The sum of leakage area should be as low as possible to prevent infection. In this research, total room leakage area of each room is set as 0.5 ft<sup>2</sup> to 1.0 ft<sup>2</sup> (0.05 to 0.09 m<sup>2</sup>)

## Isolation Rooms

The main type of room in this research is isolation room. There is four type of isolation room:

- Airborne infectious isolation rooms.
- Protective environment rooms.
- Combined AII/PE rooms.
- Contact isolation rooms.

Protective environment (PE) rooms are for patients with weakened immune disease and need special protection against infectious airborne microorganisms. The design of PE room seeks to protect patients from potential airborne infection organisms, such as fungal spores, fumigants, and Aspergillums. There are five principals for designing a PE room.

- Positive pressure with respect to all adjacent spaces. To achieve this consideration, we often design an anteroom before the patient room and provide a continuous monitor of room pressure.
- The optimum temperature is 70 °F to 75°F.
- The optimum humidity is minimum 30% relative humidity during winter and maximum 60% relative humidity during summer.
- The optimum airflow is 12 air changes per hour total.
- Air distribution pattern within the room favorable to airborne infection control.

## JUSTIFIED ACCESS DIAGRAM

### *Connective Study*

The hospital is an interconnected entity of several rooms and corridors. Sometimes people could bring dangerous microorganisms and pass through a set of rooms or corridors in the hospital. The importance of conducting space syntax of the hospital is to analysis people movement within the building in order to minimize the risk of a patient being contacted by human-bring pathogen, especially immunodeficiency people in recovery rooms. The first step of conducting the connective study is to identify the “convex space” and “non-convex space” or “concave space”.

The Figure 11 shows convex space is the space which has no corners or L-shape, any point in this space, such as the point P and point G. The straight line between this two points will never intersect the perimeter of space.

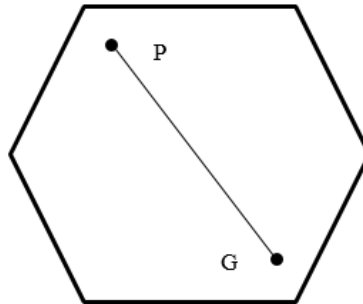

*Figure 11.* A convex space

The Figure 12 shows concave space is the space which has corners or L-shape, any point in this space, such as the point P and point G. The straight line between this two points will intersect the perimeter of space. However, a concave space could be divided into several convex spaces.

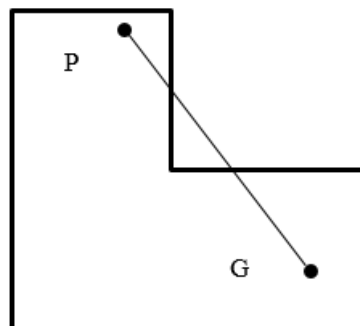

*Figure 12.* A concave space

The Figure 13 shows the plan of first floor.

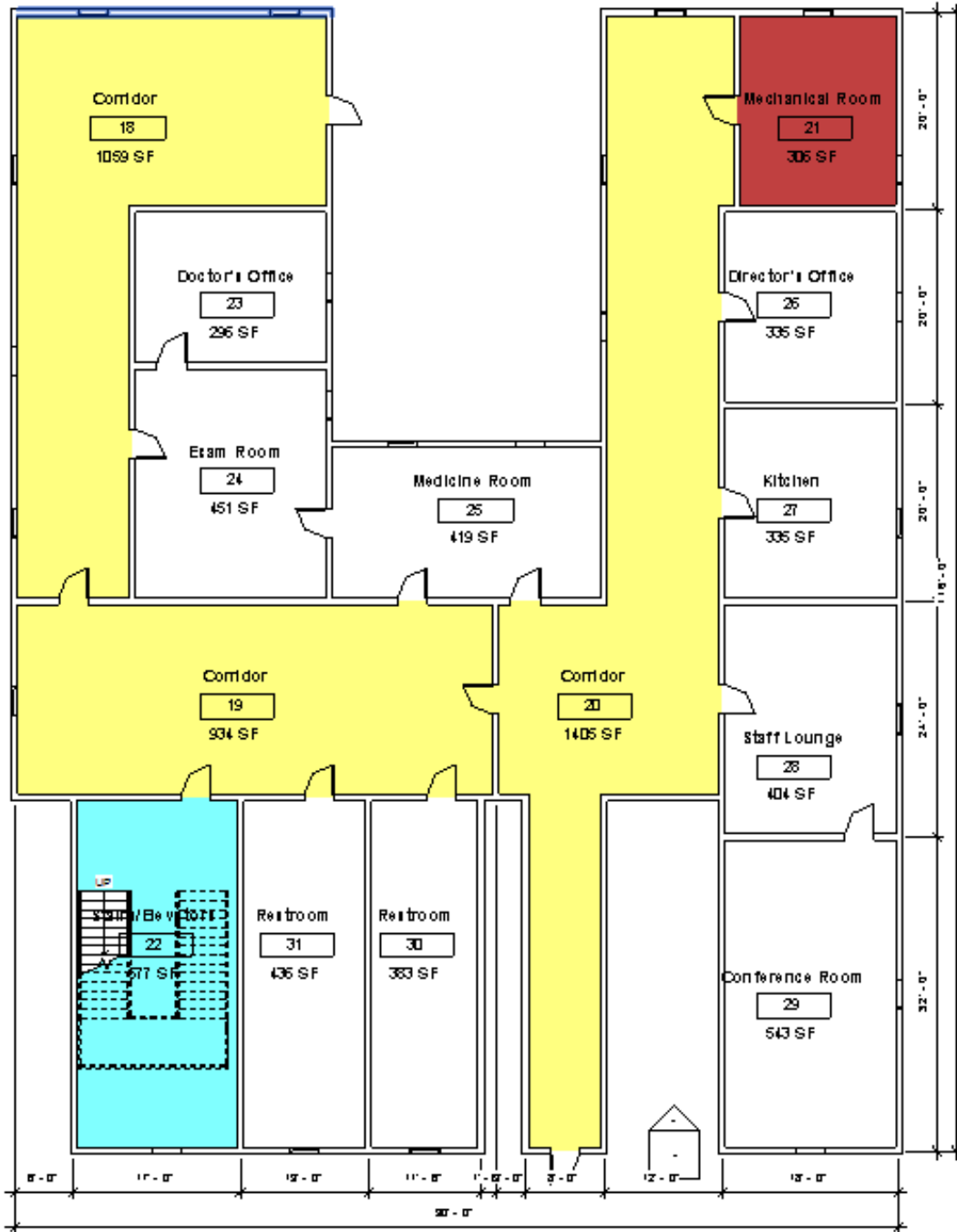

Figure 13. The floor plan of 1<sup>st</sup> floor

The Figure 14 shows the plan of second floor.

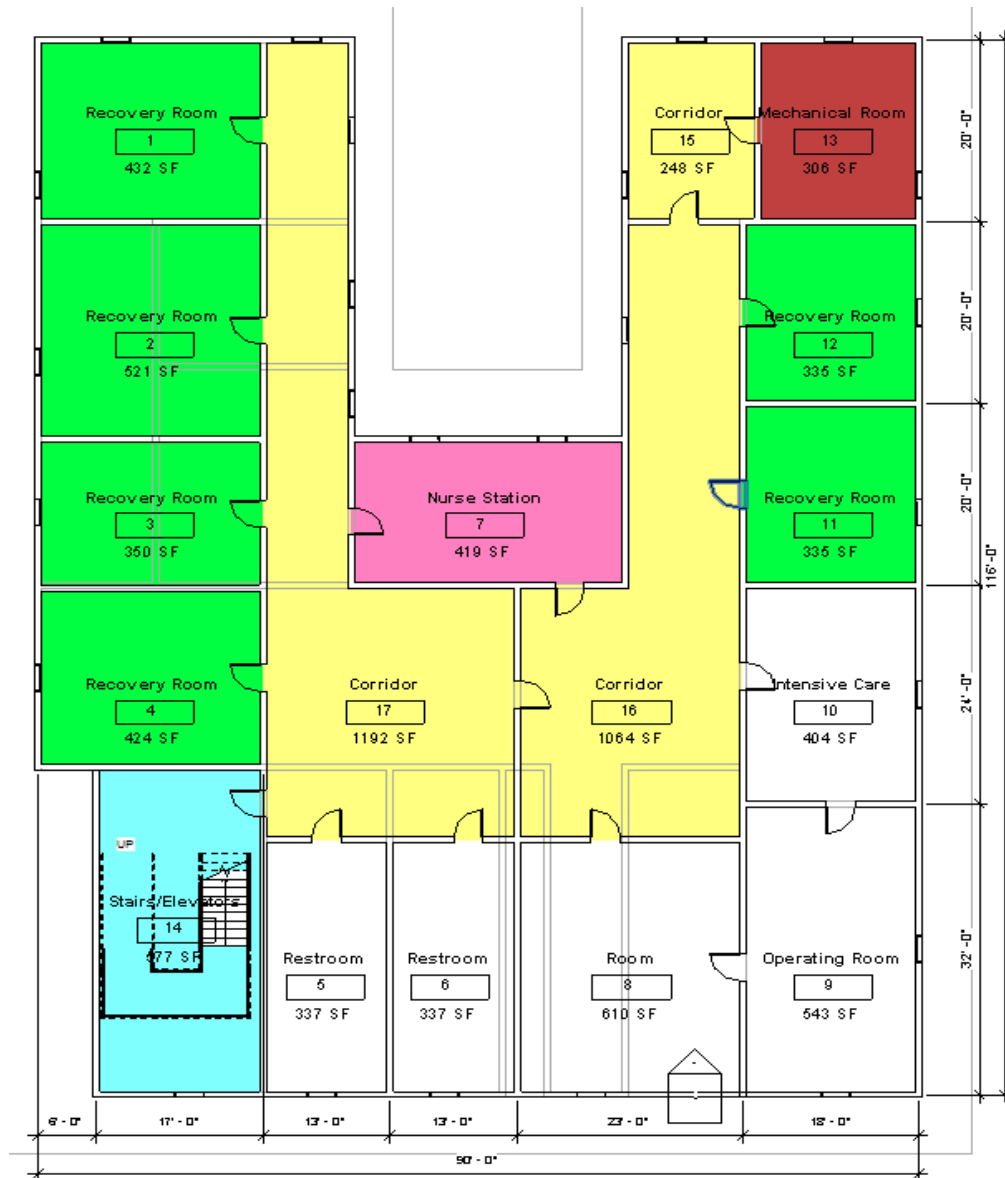

Figure 14. The floor plan of 2<sup>nd</sup> floor

From the floor plan, the yellow block represents corridors, the blue block represents stairs or elevators, the green block represents recovery rooms, the red blocks represents mechanical room and the pink block represents nurse station.

All recovery rooms are located on the second floor. These rooms are important objects in this research. While doorways, connecting corridors and stairwells are important in this research for internal circulation of patients, staff and visitors. They are all potential pathways for fungus-bearing dust and other contaminants to be spread throughout the system.

According to the floor plan, all rooms could regard as convex space. For a continuous open space, like the L shape corridor on the floor plan, we can divide it into several rectangle shape convex space. After that, we can convert the convex representation of space into a graph for future use.



## CHAPTER IV

### RESULTS

#### HVAC SYSTEM DESIGN

The first step of HVAC design for the designed hospital is to determine the ventilation CFM of each room. It is the product of the volume of room and air change rate. Based on the calculated CFM of each room, we can design the diffusers and ducts. In each room, the sum of CFM of every supply diffusers should equal to CFM of the room, also, the CFM of return diffuser should equal to CFM of supply diffuser.

The next step is to calculate ventilation load for the HVAC system. It is the product of the sum of CFM and  $\Delta T$ , which is normally 25 °C.

The load for the first floor is,  $Q_1 = 1.1 * 4395 * 25 = 120862 \text{ BTU/h} = 10 \text{ ton}$

The load for the second floor is,  $Q_2 = 1.1 * 7549 * 25 = 207597 \text{ BTU/h} = 17 \text{ ton}$

The Revit MEP could automatically select duct size based on CFM.

Table 4 shows the CFM calculation of each room in the hospital. The information from hospital design and ASHRAE Standard 170-2008.

Table 4.

*Hospital room CFM calculation*

No. of Room	Type of Room	Area of Room, ft <sup>2</sup>	Ceiling Height, ft.	Volume of Room, ft <sup>3</sup>	Minimum Total ACH, ach	CFM
2	Corridor	1059	8.5	9001	2	300
4	Corridor	934	8.5	7939	2	265
5	Exam Room	451	8.5	3833	6	383
6	Doctor's Office	296	8.5	2516	2	84
8	Restroom	436	8.5	3706	10	618
9	Restroom	383	8.5	3255	10	543
10	Medicine Room	419	8.5	3561	4	237
11	Corridor	1405	8.5	11942	2	398
15	Director's Office	335	8.5	2847	4	190
16	Kitchen	335	8.5	2847	8	380
17	Staff Lounge	404	8.5	3434	4	229
18	Conference Room	543	8.5	4615	10	769
20	Corridor	1192	8.5	10132	2	338
21	Restroom	337	8.5	2864	10	477
22	Restroom	337	8.5	2864	10	477
23	Recovery Room	424	8.5	3604	6	360
25	Recovery Room	350	8.5	2975	6	298
26	Recovery Room	521	8.5	4428	6	443
27	Recovery Room	432	8.5	2975	6	367
28	Nurse Station	419	8.5	3561	4	237
29	Corridor	1064	8.5	9044	2	301
30	Operating Prep	610	8.5	5185	20	1728
31	Operating Room	543	8.5	4615.5	20	1539
32	Intensive Care	404	8.5	3434	6	343
34	Recovery Room	335	8.5	2848	6	285
35	Recovery Room	335	8.5	2848	6	285
36	Corridor	248	8.5	2108	2	70

Figure 15 and Figure 16 show the HVAC system in the 1st floor and 2nd floor of the hospital. It containing returning, supplying and exhausting ductworks, supply, return and exhaust diffusers, air handling unit and exhauster. The blue ducts and diffusers represent air supply system and red ducts and diffusers represent air return system. And The Figure 17 shows 3D view of HVAC system.

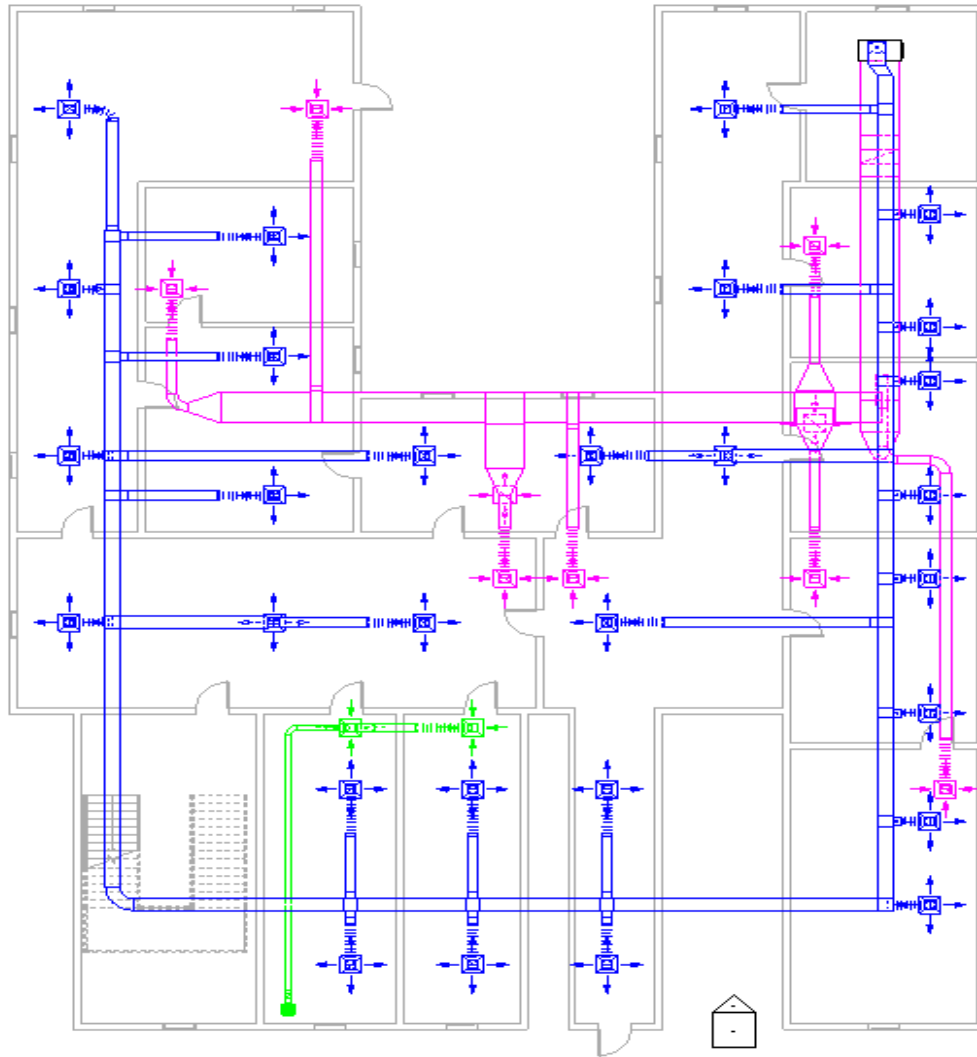

Figure 15. HVAC system on the first floor

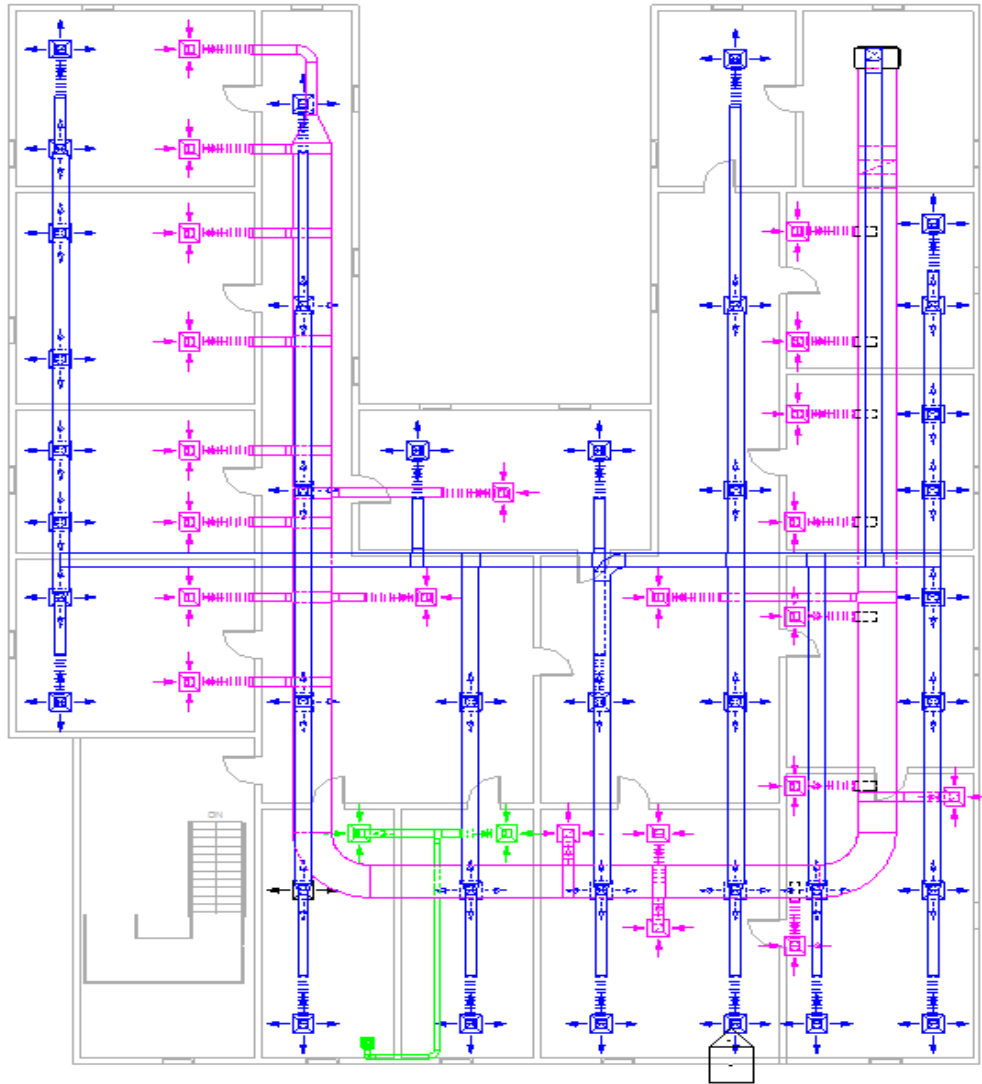
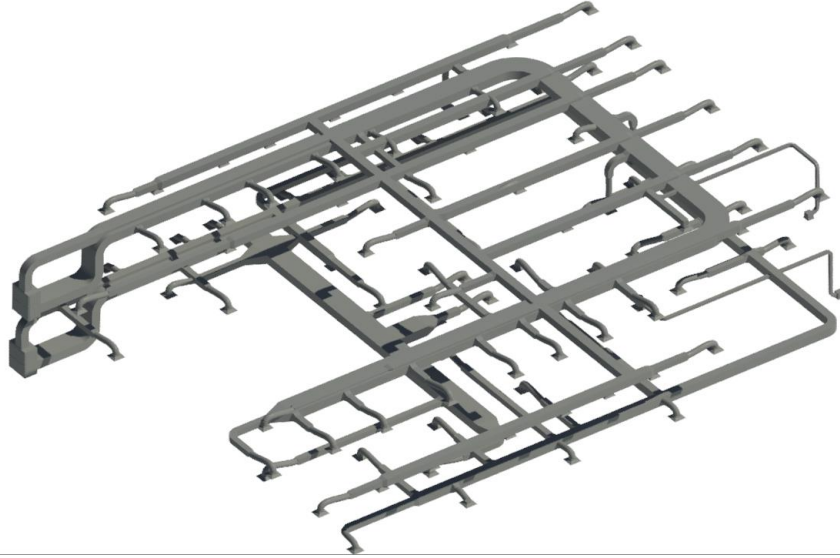

Figure 16. HVAC system on the second floor



*Figure 17.* HVAC system, 3D view

## ACCESS DIAGRAM OF HOSPITAL

### *Doorways*

Firstly, based on the floor plans of the hospital, all rooms could be regarded as convex space, and L shape corridors could be divided into two rectangles in order to view as convex space. These convex spaces are represented as a circle. Next, the spaces connect through doorways or stairs represented as a solid line.

Secondly, the convex space can be transcribed into a graph to analysis syntactic relationships among space. In this graph, the point represents spaces and lines connecting the points represent direct adjacency.

Figure 18 shows the connective study of the hospital.

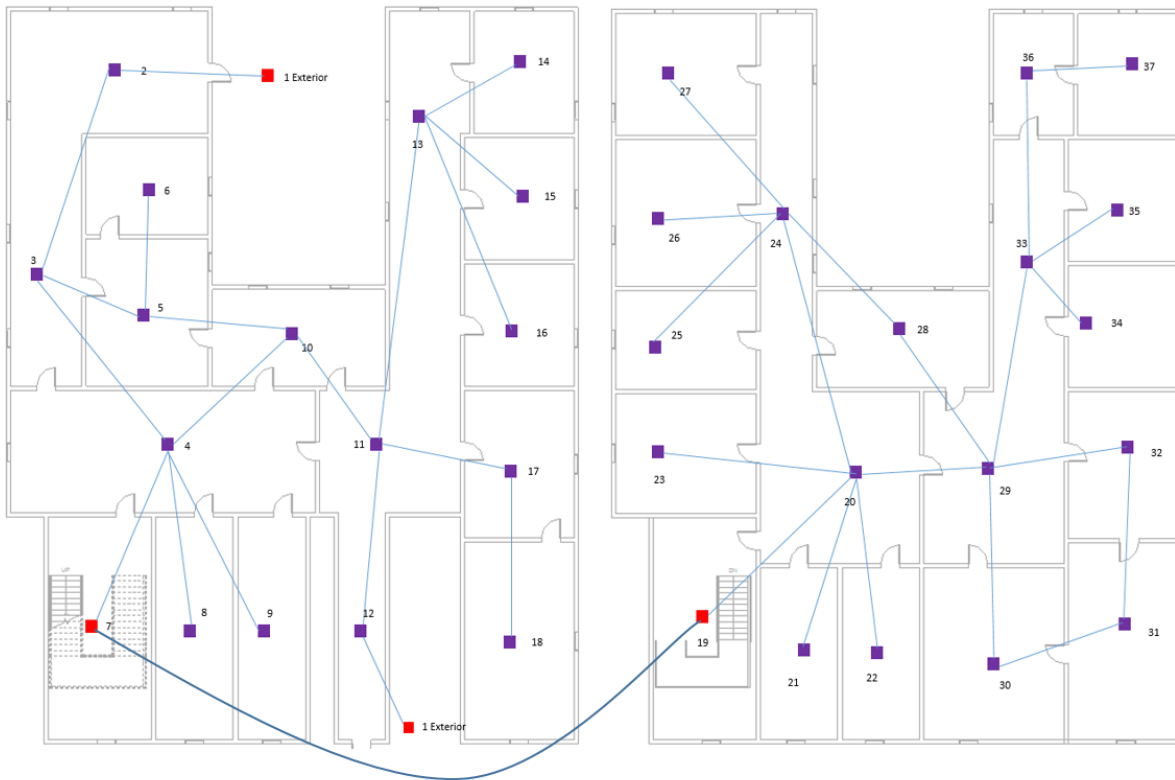

Figure 18. Connective study of the hospital

From the figure above, the left part of the figure represents the connective study of the 1<sup>st</sup> floor and right part represents the 2<sup>nd</sup> floor. There is total 37 convex space in this building and there are two entrances to the building, represented as number 1. The line between point 7 and point 19 presented as the stair that connects level one and level two of the hospital. Based on the connective study graph, we can create justified access graph to analyze of space.

Finally, in order to create a justified access diagram, we need to put the intended origin in the bottom of the diagram as a reference. It is drawn by connecting adjacent

nodes. The connected nodes present there is a pathway through two spaces. Then, the points with higher depth from the origin are placed above the origin.

The Figure 19 shows the justified access diagram of the hospital.

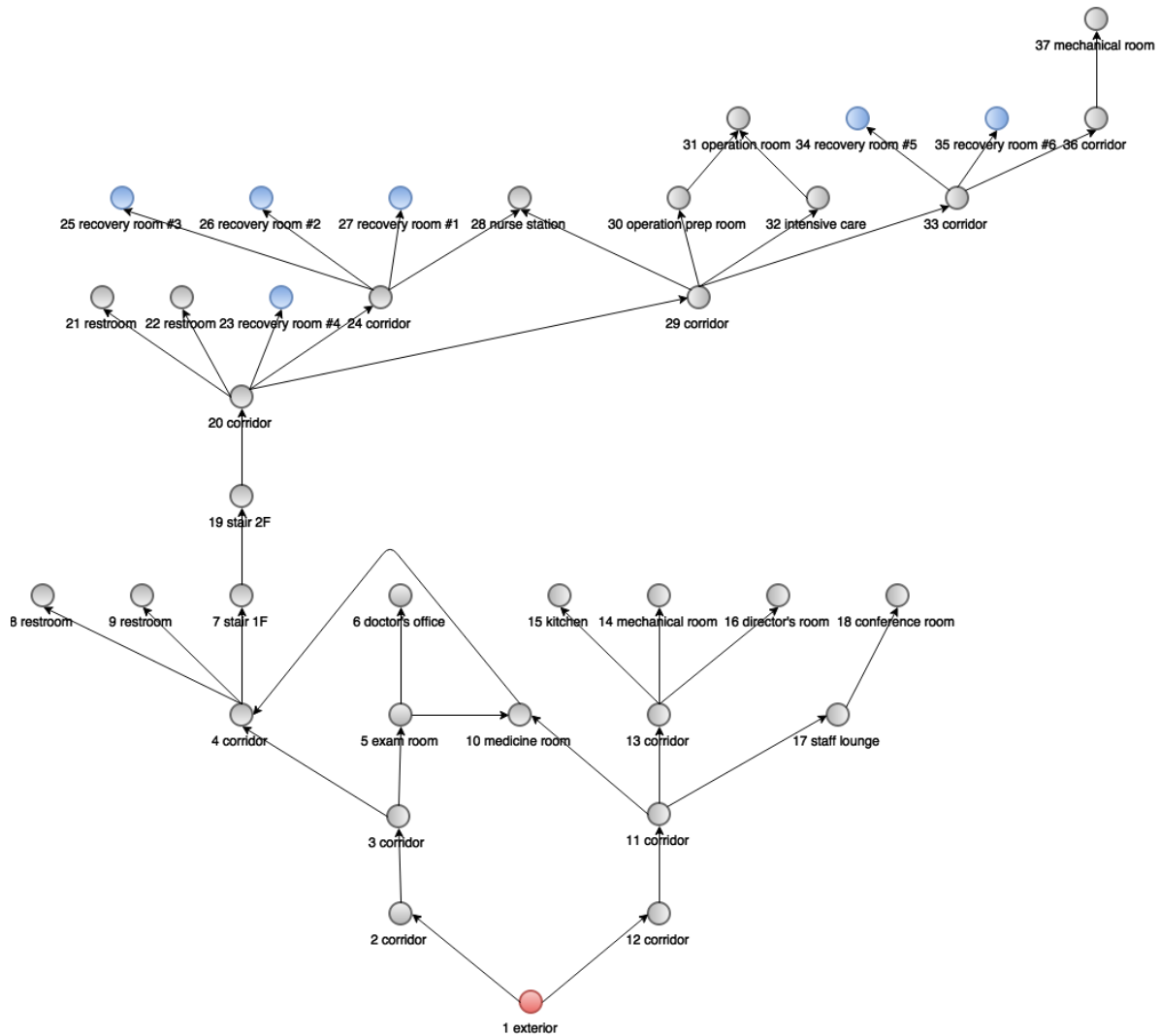

Figure 19. Justified access diagram of the hospital

Based on Figure 19, the justified access diagram, we can track people movement from the exterior (marked in red) via the entrance to each recovery rooms (marked in blue). The objective of developing this diagram is to give us an intuitionistic model to



analysis how dust could transport by people. Taking recovery room #3 as an example to track pathway from the entrance. The possible routes including:

- 1 exterior → 2 corridor → 3 corridor → 5 exam rooms → 10 medicine room → 4 corridor → 7 stair → 19 stair → 20 corridor → 24 corridor → 25 recovery room #3
- 1 exterior → 2 corridor → 3 corridor → 4 corridor → 7 stair → 19 stair → 20 corridor → 24 corridor → 25 recovery room #3
- 1 exterior → 12 corridor → 11 corridor → 10 medicine room → 4 corridor → 7 stair → 19 stair → 20 corridor → 24 corridor → 25 recovery room #3
- 1 exterior → 12 corridor → 11 corridor → 10 medicine room → 5 exam rooms → 3 corridor → 4 corridor → 7 stair → 19 stair → 20 corridor → 24 corridor → 25 recovery room #3

#### *HVAC System*

According to the design of filter in the HVAC system, although the filter type “MERV 7” used in this research could remove 50% to 70% of the particles which particle size range from 3.0 to 10  $\mu\text{m}$ , but the MERV 7 cannot remove any particles of the size range from 0.3 to 3.0  $\mu\text{m}$ . In this way, dust could also be transmitted via HVAC system to recovery rooms and jeopardize patient’s health. Similarly, we can develop similarly justified access diagram for HVAC in this hospital, in order to track dust movement throughout HVAC system.

The dust in mechanical supply air system comes from air handling unit located at the exterior of the building, then dust is transmitted to the terminal box such as VAV

box. After that, dust comes to supply diffusers via duct system. Finally, dust enters the recovery room.

The next step is to create the connectivity graph of the HVAC system to analyze the syntactic relations among space. The convex space in this graph is the same as previous one. Different from the previous connectivity study, this graph is drawn based on air distribution system, in this way, how ducts are placed is critical thing need identified.

The Figure 20 shows connectivity study of HVAC system.



Figure 20. The connectivity study of the HVAC system in the hospital

We can then draw the justified access diagram. According to the same rule, we need to put the origin, the exterior, at the bottom of the graph. Figure 21 shows the justified access diagram for HVAC system.

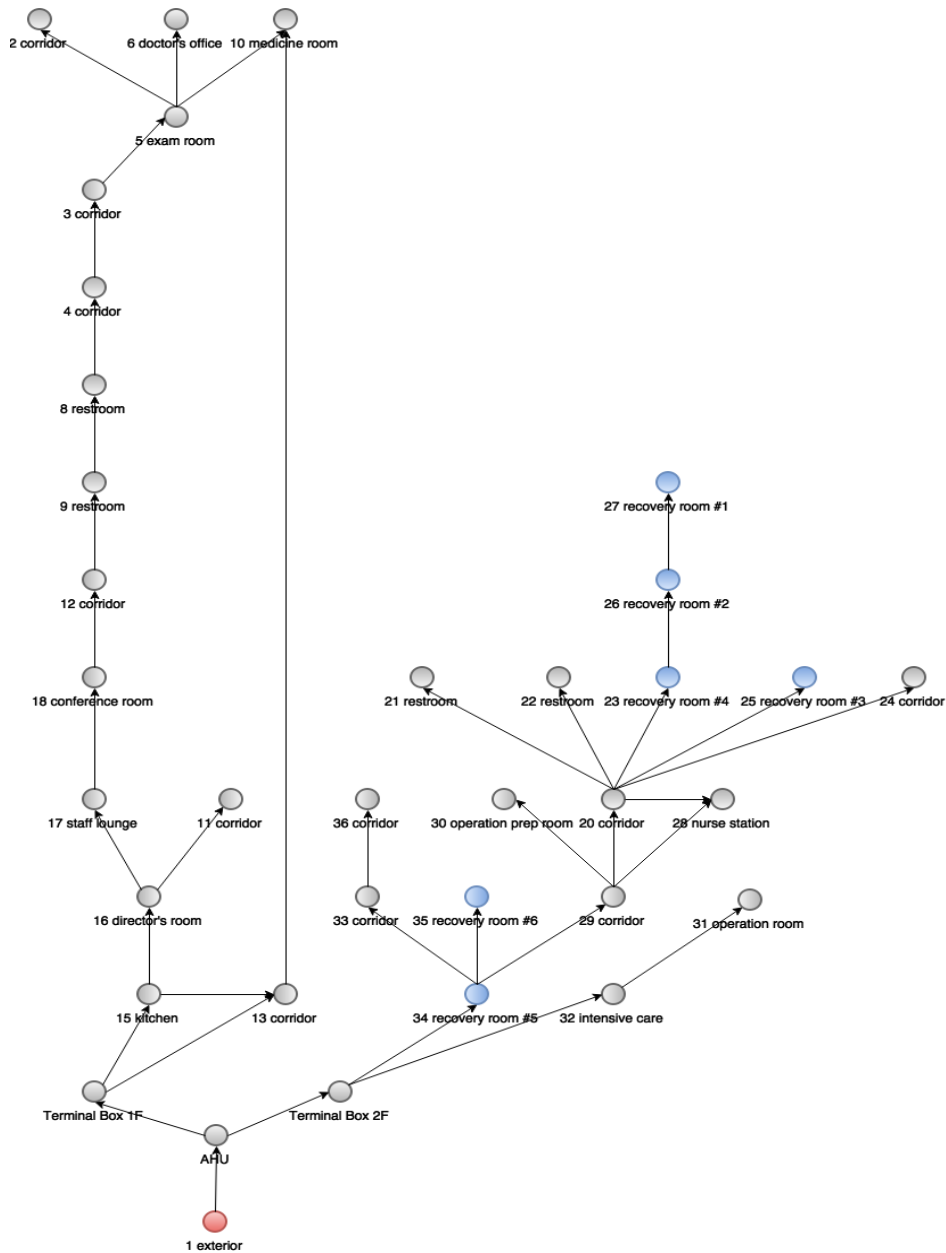

Figure 21. Justified access diagram of the HVAC system in the hospital

We can track dust movement from exterior (marked in red) via HVAC system to the recovery room (marked in blue) according to this diagram. Taking recovery room #3 as an example, the possible routes are:

- 1 exterior → AHU → Terminal Box 2F → 34 recovery room #5 → 29 corridor → 20 corridor → 24 corridor → 25 recovery room #3
- 1 exterior → AHU → Terminal Box 2F → 34 recovery room #5 → 29 corridor – 28 nurse station → 20 corridor → 24 corridor → 25 recovery room #3

In summary, Table 5 shows the comprehensive route for dust from exterior to recovery room through both doorways and HVAC system.

Table 5.

*Summary of all possible routes to recovery room #3*

People	HVAC
1 exterior → 2 corridor → 3 corridor → 5 exam rooms → 10 medicine room → 4 corridor → 7 stair → 19 stair → 20 corridor → 24 corridor → 25 recovery room #3	1 exterior → AHU → Terminal Box 2F → 34 recovery room #5 → 29 corridor → 20 corridor → 24 corridor → 25 recovery room #3
1 exterior → 2 corridor → 3 corridor → 4 corridor → 7 stair → 19 stair → 20 corridor → 24 corridor → 25 recovery room #3	1 exterior → AHU → Terminal Box 2F → 34 recovery room #5 → 29 corridor → 28 nurse station → 20 corridor → 24 corridor → 25 recovery room #3
1 exterior → 12 corridor → 11 corridor → 10 medicine room → 4 corridor → 7 stair → 19 stair → 20 corridor → 24 corridor → 25 recovery room #3	
1 exterior → 12 corridor → 11 corridor → 10 medicine room → 5 exam rooms → 3 corridor → 4 corridor → 7 stair → 19 stair → 20 corridor → 24 corridor → 25 recovery room #3	

As we discussed in the early chapter, the possible routes dust entering a certain space including:

- People carry.
- HVAC system.
- Infiltration from floors, ceilings, walls, etc.

In the next part of the research, the author chooses Recovery Room 3 at the second floor as an example of analysis how dust enters the room. Figure 22 shows all of the possible routes.

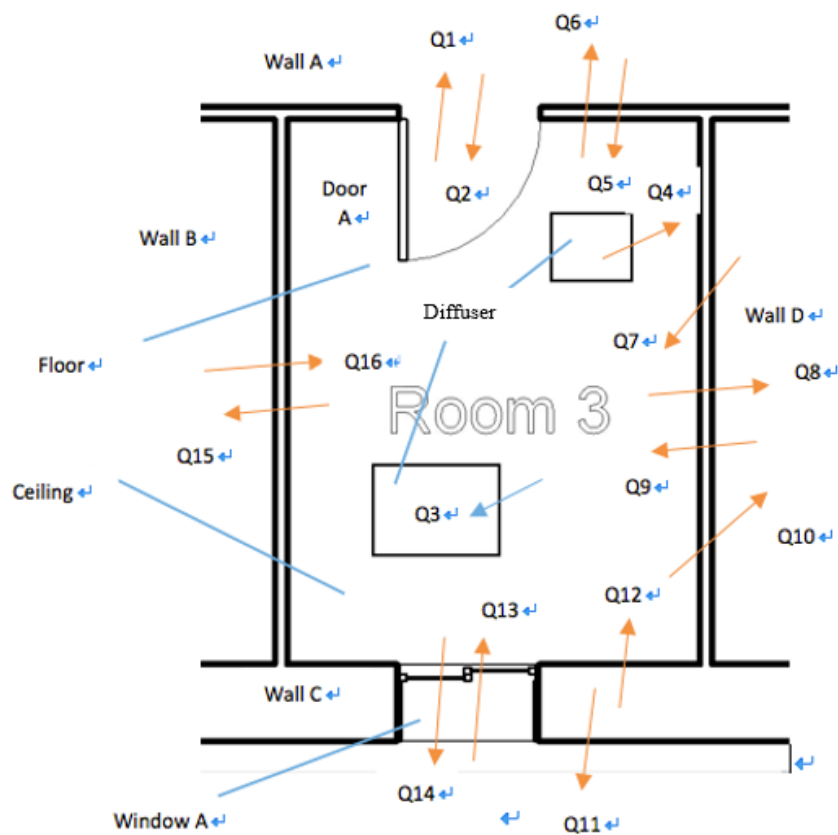

Figure 22. How dust enters Recovery Room #3

In this diagram, the direction of the arrow represents the direction of dust movement. There is always a pair of arrows with opposite direction at each critical point, which means the dust could either enter or leave the space. This direction is mainly determined by differential space between adjacent spaces. Taking  $Q_1$  and  $Q_2$  as an instance. If the room pressure is higher than the corridor pressure, the  $Q_1$ , which dust moves from room to corridor, becoming dominant. Otherwise, the  $Q_2$  becomes dominant, which means most dust enters the room.

There are two different colors of the arrow: the red one represents contaminated air that containing fungus, the blue one represents clean air. We also categories the critical level of contaminated air into three levels: high, medium and low. The highest level of infection comes from doorways and supply air diffusers. In this study, we can use justified access diagram to analysis it. The middle-level risk comes from windows and the lowest level risk comes from infiltration of walls, floors, ceilings.

The Table 6 summarizes major source of the contaminant enters recovery room #3.

Table 6.

*Summaries of dust sources to Room 25*

Q	Critical Level	Direction
Q <sub>0</sub>	High	Room 25 → Door → Corridor 24
Q <sub>1</sub>	High	Corridor 24 → Door → Room 25
Q <sub>2</sub>	High	Room 25 → Return Diffuser
Q <sub>3</sub>	High	Supply Diffuser → Room 25
Q <sub>4</sub>	High	Corridor 24 → Wall D → Room 25
Q <sub>5</sub>	Low	Corridor 24 → Wall A → Room 25
Q <sub>6</sub>	Low	Room 25 → Wall A → Corridor 24
Q <sub>7</sub>	Low	Roof → Ceiling → Room 25
Q <sub>8</sub>	Low	Room 25 → Wall D → Room 23
Q <sub>9</sub>	Low	Room 23 → Wall D → Room 25
Q <sub>10</sub>	Low	Room 25 → Ceiling → Roof
Q <sub>11</sub>	Low	Room 25 → Wall C → Outside
Q <sub>12</sub>	Low	Outside → Wall C → Room 25
Q <sub>13</sub>	Medium	Outside → Window A → Room 25
Q <sub>14</sub>	Medium	Room 25 → Window A → Outside
Q <sub>15</sub>	Low	Room 25 → Wall B → Room 26
Q <sub>16</sub>	Low	Room 26 → Wall B → Room 25



## CHAPTER V

### CONCLUSION

This chapter outlines analysis of results obtained, the conclusion from the results and new topic for further research.

The existence of dust in the hospital poses serious threat to patients in the hospital. This paper explains how dust moving throughout the healthcare facilities and provides a theoretical framework for analyzing dust movement using space syntax diagramming. Space syntax technique is the method describing the network properties of spaces in terms of visibility and accessibility. In this research, the objective is to analyze the accessibility of people moving from the exterior to a certain place, since humans could carry dust and this is the most critical source regarding hospital infection, this paper also analyzes the accessibility of dust via HVAC system. By identifying convex space, conducting connectivity study and generating justified access diagram. We can then track all of the possible routes of dust.

This research provides a general guideline for scientists and engineers to analyze dust movement in all types of building and brings a new point of view about infection control topic in healthcare facilities. In the further study, we could use space syntax theory as a guideline to the design of healthcare facilities. For example, by conducting a justified access analyze, we could compare multiple design proposal and integrate various factors such as floor plan, spatial layout, HVAC distribution system layout, human behavior to determine which design is the most “safest” one in terms of dust infection control issue. Also, we investigated the most critical path on the justified access

diagram, and conduct depth value analysis in the graph, to adopt special infection protection measurements at this critical location.

A limitation of these research is that the one justified access diagram could only analysis one single source of dust. In this way, a new model that integrates different routes, including doorways, HVAC system, infiltration, etc., should be achieved and these model be able to tell us which route has a higher proportion of dust. In addition, the direction of contaminant air is determined by room pressure, according to Krupal's analysis of differential room pressure, the pressure varies frequently within a fixed time, demonstrate a cyclical pattern and it is hard for the reader to follow. In this way, this new model should also solve this problem.

## REFERENCES

- ASHRAE. (1999). HVAC applications. Atlanta, GA, American Society of Heating, Refrigerating and Air-conditioning Engineers.
- ASHRAE. (2007). "HVAC applications." ASHRAE Handbook, Fundamentals(2003).
- Bafna, S. (2003). "SPACE SYNTAX A brief introduction to its logic and analytical techniques." Environment and Behavior **35**(1): 17-29.
- Bassett, A. J. (2013). Comparison test for infection control barriers for construction in healthcare. College Station, TX, Texas A&M University. **M.S.**
- Bhatt, K. (2016). Effect of construction dust on patients and workers health: a qualitative risk analysis. Texas A&M University.
- Cheong, K. and S. Phua (2006). "Development of ventilation design strategy for effective removal of pollutant in the isolation room of a hospital." Building and Environment **41**(9): 1161-1170.
- Chiaradia, A., et al. (2009). "Spatial centrality, economic vitality/viability: Compositional and spatial effects in Greater London."
- Dols, W. (2001). "A tool for modelling airflow & contaminant transport." ASHRAE Journal **23**(3): 35-42.
- Dols, W. S. (2001). "A tool for modeling airflow & contaminant transport." Ashrae Journal **43**(3): 35.
- Geshwiler, M., et al. (2003). HVAC design manual for hospitals and clinics. Atlanta, GA: American Society of Heating, Refrigerating, and Air-Conditioning Engineers, Inc.
- Haq, S.-U. (1999). Can space syntax predict environmental cognition. Space Syntax second international symposium.
- Hillier, B. and J. Hanson (1989). The social logic of space. Cambridge, UK, Cambridge university press.
- Khan, N. (2012). Analyzing patient flow: Reviewing literature to understand the contribution of space syntax to improve operational efficiency in healthcare settings. Short paper presented at the 8th International Space Syntax Symposium, Chile.

Kim, Y. and H. W. Lee (2010). "Analyzing user costs in a hospital: methodological implication of space syntax to support whole-life target value design." Lean Constr. J **11**: 55-63.

Klarqvist, B. (1993). "A space syntax glossary." Nordisk Arkitekturforskning **2**(1).

Machida, M. and K. Gomi (2010). Aspergillus: molecular biology and genomics, Horizon Scientific Press.

Malik, O., et al. (2008). "Controlling Hospital-Acquired Infections, Role of Industrial Hygienists." Falls Church, VA: American Industrial Hygiene Association AIHA.

Papadopoulos, I. (2015). "Building Healthy Hospitals and their relation with Medical Tourism Trend."

Raford, N. and D. Ragland (2004). "Space syntax: Innovative pedestrian volume modeling tool for pedestrian safety." Transportation Research Record: Journal of the Transportation Research Board(1878): 66-74.

Reboux, G., et al. (2014). "A 10-year survey of fungal aerocontamination in hospital corridors: a reliable sentinel to predict fungal exposure risk?" Journal of Hospital Infection **87**(1): 34-40.

Reboux, G., et al. (2014). "A 10-year survey of fungal aerocontamination in hospital corridors: a reliable sentinel to predict fungal exposure risk?" J Hosp Infect **87**(1): 34-40.

Sehulster, L., et al. (2003). "Guidelines for environmental infection control in health-care facilities." Morbidity and Mortality Weekly Report Recommendations and Reports RR **52**(10).

Sehulster, L. and R. Y. W. Chinn (2003). Guidelines for Environmental Infection Control in Health-Care Facilities. MMWR Recommendations and Reports. Atlanta, CDC.

Van Loan, C. (1992). Computational frameworks for the fast Fourier transform, Siam.

Zadeh, R. S., et al. (2012). "Rethinking efficiency in acute care nursing units: Analyzing nursing unit layouts for improved spatial flow." HERD: Health Environments Research & Design Journal **6**(1): 39-65.

Zhang, T. and Q. Chen (2007). "Identification of contaminant sources in enclosed environments by inverse CFD modelling." Indoor Air **17**(3): 167-177.