

University of Windsor

Scholarship at UWindsor

Electronic Theses and Dissertations

Theses, Dissertations, and Major Papers

1-22-2020

Adaptive Transmission Power Level with Vehicle Speed Approximation of Density for VANET Congestion Control

Caitlin Facchina
University of Windsor

Follow this and additional works at: <https://scholar.uwindsor.ca/etd>

Recommended Citation

Facchina, Caitlin, "Adaptive Transmission Power Level with Vehicle Speed Approximation of Density for VANET Congestion Control" (2020). *Electronic Theses and Dissertations*. 8298.
<https://scholar.uwindsor.ca/etd/8298>

This online database contains the full-text of PhD dissertations and Masters' theses of University of Windsor students from 1954 forward. These documents are made available for personal study and research purposes only, in accordance with the Canadian Copyright Act and the Creative Commons license—CC BY-NC-ND (Attribution, Non-Commercial, No Derivative Works). Under this license, works must always be attributed to the copyright holder (original author), cannot be used for any commercial purposes, and may not be altered. Any other use would require the permission of the copyright holder. Students may inquire about withdrawing their dissertation and/or thesis from this database. For additional inquiries, please contact the repository administrator via email (scholarship@uwindsor.ca) or by telephone at 519-253-3000ext. 3208.

Adaptive Transmission Power Level with Vehicle Speed

Approximation of Density for VANET Congestion Control

By

Caitlin Facchina

A Thesis

Submitted to the Faculty of Graduate Studies

Through the School of Computer Science

In Partial Fulfillment of the Requirements for

The Degree of Master of Science

At the University of Windsor

Windsor, Ontario, Canada

2020

© 2020 C. Facchina

Adaptive Transmission Power Level with Vehicle Speed

Approximation of Density for VANET Congestion Control

By

Caitlin Facchina

Approved By:

W. Anderson

Department of Political Science

C. Ezeife

School of Computer Science

A. Jaekel, Advisor

School of Computer Science

January 22, 2020

Declaration of Originality

I hereby certify that I am the sole author of this thesis and that no part of this thesis has been published or submitted for publication.

I certify that, to the best of my knowledge, my thesis does not infringe upon anyone's copyright nor violate any proprietary rights and that any ideas, techniques, quotations, or any other material from the work of other people included in my thesis, published or otherwise, are fully acknowledged in accordance with the standard referencing practices. Furthermore, to the extent that I have included copyrighted material that surpasses the bounds of fair dealing within the meaning of the Canada Copyright Act, I certify that I have obtained a written permission from the copyright owner(s) to include such material(s) in my thesis and have included copies of such copyright clearances to my appendix.

I declare that this is a true copy of my thesis, including any final revisions, as approved by my thesis committee and the Graduate Studies office, and that this thesis has not been submitted for a higher degree to any other University or Institution.

Abstract

Vehicles travelling and communicating with each other and infrastructure is the basis of the future of vehicular transportation. There are many possible applications of communication in a vehicular network. One of the more important applications is for safety. Safety messages exchanged between vehicles can possibly be life-saving. However, if such messages are not received in a timely or reliable manner, a safety application's effectiveness could suffer. As such, network congestion control is a popular topic in vehicular networks. Various methods of controlling the message transmission rate and power have been explored to-date.

In this thesis we propose an algorithm which manipulates the transmission power based on a density estimation derived from the vehicle's driving speed, and compare it to methods observing only speed, only density, or other factors. Analysis of the results was done through simulation software. Results showed that the proposed algorithm reduced symptoms of channel congestion at least as effectively as the related density-based algorithm, and much better than using no congestion control algorithm at all. This thesis also adds "relevance" as a new measurement of performance by observing the proportion of packets received from certain distances at each vehicle.

Contents

Declaration of Originality	iii
Abstract.....	iv
List of Figures.....	vii
List of Tables	vii
List of Acronyms	viii
Chapter 1 Introduction.....	1
1.1. Introduction	1
1.2 Motivation	2
1.3. Problem statement	3
1.4. Solution outline	3
1.5. Thesis organization	4
Chapter 2 Background.....	5
2.1 Motivation	5
2.1.1 Basic Safety Messages and Safety Applications.....	6
2.2 Terminology.....	8
2.2.1 Performance Criteria Terminology.....	9
2.3. Important/fundamental concepts	10
2.3.1 DSRC and WAVE Technologies	11
2.3.2 Congestion and Packet Loss	11
2.3.3 Congestion Control Algorithms	12
2.4. Current Research Problems and Solutions	12
2.5. Literature review	14
Chapter 3 Proposed Algorithm	18
3.1 Introduction	18
3.2 High-level Overview.....	18
3.2.1 Speed assessment.....	18
3.2.2 Transmission Power Calculation	19
3.2.3 Power Assignment.....	19
3.3 Proposed Algorithm	20
3.3.1 Example	24
3.4 How the proposed algorithm differs from prior work	25

Chapter 4 Simulations and Results	27
4.1 Simulation	27
4.1.1 Simulation Setup	28
4.2 Simulation Results	30
4.2.3 Packets Sent	30
4.2.4 Packets Received	32
4.2.3 Packets Lost	34
4.2.4 Beacon Reception Rate	37
4.2.5 Beacon Error Rate	38
4.2.6 Channel Busy Time	41
4.2.7 Inter-Packet Delay	43
4.2.8 Relevance	47
Chapter 5 Conclusions and Future Work	52
5.1 Conclusions	52
5.2 Future Work	52
References	54
Vita Auctoris	59

List of Figures

- Figure 2.1 Traffic Collision Statistics 6
- Figure 2.2 WAVE Architecture11
- Figure 3.1 Proposed DCC algorithm20
- Figure 3.2 Proposed algorithm flow chart23
- Figure 4.1 Graphical depiction of simulation software setup.....28
- Figure 4.2 Packets sent in the six-lane highway simulation31
- Figure 4.3 Packets sent in the 12-lanes fast highway simulation31
- Figure 4.4 Packets sent in the 12-lanes slow highway simulation32
- Figure 4.5 Packets received in the 6-lane highway simulation.....33
- Figure 4.6 Packets received in the 12-lane fast highway simulation33
- Figure 4.7 Packets received in the 12-lane slow highway simulation.....34
- Figure 4.8 Packets lost in the 6-lane highway simulation35
- Figure 4.9 Packets lost in the 12-lane fast highway simulation.....36
- Figure 4.10 Packets lost in the 12-lane slow highway simulation36
- Figure 4.11 BRR in the 6-lane highway simulation37
- Figure 4.12 BRR in the 12-lane fast highway simulation38
- Figure 4.13 BRR in the 12-lane slow highway simulation38
- Figure 4.14 BER in the 6-lane highway simulation39
- Figure 4.15 BER in the 12-lane fast highway simulation.....40
- Figure 4.16 BER in the 12-lane slow highway simulation40
- Figure 4.17 CBT in the 6-lane highway simulation42
- Figure 4.18 CBT in the 12-lane fast highway simulation.....42
- Figure 4.19 CBT in the 12-lane slow highway simulation43
- Figure 4.20 IPD in the 6-lane highway simulation.....45
- Figure 4.21 IPD in the 12-lane fast highway simulation46
- Figure 4.22 IPD in the 12-lane slow highway simulation.....47
- Figure 4.23 Relevance of packets in the 6-lane highway simulation.....49
- Figure 4.24 Relevance of packets in the 12-lane fast highway simulation50
- Figure 4.25 Relevance of packets in the 12-lane slow highway simulation.....51

List of Tables

- Table 4.1 Simulation parameters for each highway scenario.....29

List of Acronyms

BSM - Basic Safety Message

ITS - Intelligent Transportation Systems

DSRC - Dedicated Short-Range Communications

DCC - Decentralised Congestion Control

MAC - Medium Access Control

V2V - Vehicle-to-Vehicle Communication

V2I - Vehicle-to-Infrastructure Communication

RSU - Roadside Unit

WAVE - Wireless Access in Vehicular Environments

BER - Beacon Error Rate

BRR - Beacon reception rate

CBR/CBT - Channel Busy Ratio/Channel Busy Time

IPD - Inter Packet Delay

VANET – Vehicular Ad-hoc Network

Chapter 1 Introduction

1.1. Introduction

Ad hoc networks are a set of interconnected devices with the ability to communicate. However, what makes an ad hoc network unique is its decentralization. Rather than relying on devices such as routers or access points to give a predefined structure to communication, each host on the network acts as a router itself and talks directly to the other hosts. Ad hoc networks are extremely useful when the network needs to be highly volatile, with hosts coming and going frequently such as in mobile ad hoc networks (MANET).

A Vehicular Ad Hoc Network (VANET), as its name implies, is a MANET where the hosts are vehicles. It is easy to see why the communication between vehicles should be implemented on an ad hoc network rather than a standard wireless network. Vehicles are extremely mobile. As such, relying on being in range of any sort of hardware or access point is definitely out of the question when you never know who will be your neighbour from one minute to the next.

VANETs operate on the basic premise of vehicles talking to one another, which is called vehicle to vehicle (V2V) communication. However, there are extensions to the basic V2V structure which include the ability for road infrastructure to communicate to vehicles, called Vehicle to Infrastructure (V2I) communication, which allows vehicles to communicate with road infrastructure such as overpasses or roadside signs. Dedicated Short Range Communication (DSRC) is one technology currently used in V2V and V2I communication. According to the United States Department of Transportation, DSRC is described as “a two-way short- to- medium-range wireless communications capability that permits very high data transmission critical in communications-based active safety applications” (Sill, 2012). DSRC in the U.S.A. operates on the spectrum from 5.850 GHz to 5.925 GHz (Kenney, 2011, Section 3). Essentially, DSRC is a

fast Wi-Fi with little overhead to allow fast enough communication for VANET use (Al-Sultan, Al-Doori, Al-Bayatti, & Zedan, 2014). 802.11p, a wireless protocol standardized for wireless access in vehicular environments (WAVE), works in accordance with DSRC. WAVE is an architecture standardized for short range vehicular communication. Of course, some hardware is necessary for signals to be transmitted. On a vehicle we call this an On-Board unit (OBU) and on infrastructure we call this a Road-Side Unit (RSU).

1.2 Motivation

Why do vehicles need to communicate with each other? There are several applications for this, many of which involve safety or accident prevention. According to (Hartenstein & Laberteaux, 2008), "Vehicle Safety Communications (VSC) consortium identified eight high potential applications: traffic signal violation warning, curve speed warning, emergency electronic brake light, pre-crash sensing, cooperative forward collision warning, left turn assistant, lane-change warning, and stop sign movement assistant." However, if there are too many messages being sent at the same time this can result in collision and packet loss (Le, Baldessari, Salvador, Festag, & Zhang, 2011), meaning the failure to send Basic Safety Messages (BSMs) and this could potentially cost human life.

Congestion control is a common problem in networking. In a wireless network, a common technique is the Carrier Sense Multiple Access with Collision Avoidance protocol (CSMA/CA), in which the wireless medium is tested to be idle or busy before transmission. In some cases, a Request to Send (RTS) and Clear to Send (CTS) packets are used to check idleness. However, in ad hoc networks such as VANET, when dealing with safety applications, the timeliness of the BSM arrival can make a world of difference. There may be no time for lengthy transmission requests and approvals, especially if an accident may be prevented.

1.3. Problem statement

In a perfect world, every BSM sent would be received correctly in a timely manner by its intended recipients (vehicles within a certain range of the transmitter) with adequate time and information to perform whatever task is required by the safety application employed. However, VANETs encounter several challenges due to various obstacles such as message overhead, inefficiencies in bandwidth and resource usage, transmission delay and other related factors which can affect the performance of a network and applications that rely on it.

In VANETs, all vehicles compete for resources, i.e. available bandwidth for transmitting packets. Vehicles can typically transmit up to 10 beacons or BSMs per second (Xu & Sengupta, 2004). In such networks, transmitting vehicles must constantly test the broadcasting medium for activity, and only transmit their own messages when no activity is sensed on the channel i.e. the channel being sensed as idle. This can cause a significant amount of overlap, delay, and packet collisions resulting in loss of awareness in the network and the suffering of safety applications. In IEEE standards, network resource allocation is often managed in a centralized manner (Bhattarai, Naik, & Park, 2019), however in VANETs this is not an option as a decentralized, highly volatile network. Since BSMs are broadcast to all neighboring vehicles, such packets are not acknowledged (an acknowledgement explosion would occur). MAC transmission delays and packet loss increase exponentially when VANET channel load is above 40% of the theoretical capacity (Smely, Rührup, Schmidt, Kenney, & Sjöberg, 2015).

1.4. Solution outline

Since resources are not managed centrally in VANETs, we must manage them in a decentralized manner. Since the channel load and vehicles' own transmission rates and transmission are the primary cause for adverse effects on transmissions, it makes sense that managing these factors influences managing channel congestion. In this paper, an approach is

proposed which adapts each vehicles transmission power according to its own speed. The idea here is that the faster a vehicle is travelling, the less dense the network is (as vehicles need to leave more space at higher speeds). With more space between vehicles, higher transmission powers can be used, while a low speed traffic network may suffer from heavy congestion at the same power. Thus, the lower speed vehicles reduce their transmission power. The approach aims to reduce inter-packet delay, channel busy time, and beacon error rate while improving beacon relevance (to be discussed in chapter 3 and 4) thereby improving the performance of the network. The results of simulations run using this approach will be discussed in chapter 4 of this paper.

1.5. Thesis organization

After this chapter the remaining portions of this thesis will be organized in the following manner. Chapter 2 will consist of a literature review of previous work done in the area of VANET congestion control, with a focus on approaches manipulating transmission power and very well-cited works. Chapter 3 will discuss the proposed congestion control approach in detail and how it differs from existing approaches. Chapter 4 will outline simulation parameters and settings, and the results of simulations run with the algorithm proposed in chapter 3 while comparing results from other approaches. Finally, chapter 5 will discuss the conclusions of the work completed and future work to be done on it.

Chapter 2 Background

This chapter describes important terminology, motivation, fundamental concepts, and prior work done in the area of VANET congestion control.

2.1 Motivation

Safety applications in VANETs have a lot of potential to avoid casualties. In 2017 in Canada alone, there were 1679 fatal motor vehicle collisions and 112,479 collisions causing injury as shown in Figure 2.1 (“Canadian Motor Vehicle Traffic Collision Statistics: 2017—Transport Canada,” n.d.). In a VANET employing safety applications to prevent collisions or other safety features, a late or undelivered BSM could be the difference between receiving a collision warning, and none. It could then mean the difference between experiencing a collision or not. Therefore, it is essential to avoid as many lost and late BSMs in the network as possible. A high transmission power coupled with frequent transmissions and a dense network is a recipe for congestion. More vehicles transmitting frequently at a high power almost guarantees excessive overlap. A congested network will have a higher channel busy rate, a higher beacon error rate, a lower beacon delivery rate, and a higher inter-packet delay (as described in chapter 4 of this document).

Year	Collisions		Victims		
	Fatal ¹	Personal Injury ²	Fatalities ³	Serious Injuries ⁴	Injuries ⁵ (Total)
1998	2,583	145,615	2,919	16,410	213,319
1999	2,632	148,683	2,980	16,187	218,457
2000	2,548	153,290	2,904	15,581	222,848
2001	2,415	149,023	2,758	15,296	216,542
2002	2,583	153,832	2,921	15,894	222,665
2003	2,487	150,493	2,777	15,110	216,123
2004	2,438	145,150	2,735	15,572	206,104
2005	2,551	145,559	2,898	15,792	204,701
2006	2,586	142,517	2,871	16,044	199,976
2007	2,455	138,615	2,753	14,410	192,745
2008	2,193	127,571	2,431	12,851	176,394
2009	2,007	123,449	2,216	11,955	170,770
2010	2,021	123,615	2,238	11,796	172,081
2011	1,849	122,350	2,023	10,940	167,741
2012	1,848	122,835	2,075	11,104	166,728
2013	1,772	120,371	1,954 [£]	10,661	164,525
2014	1,678	114,600	1,848	10,422	156,366
2015	1,701 [£]	117,844 [£]	1,882 [£]	10,856 [£]	161,056 [£]
2016	1,731 [£]	116,473 [£]	1,895 [£]	10,760 [£]	163,245 [£]
2017	1,679	112,479	1,841	9,960	154,886

Figure 2.1 Traffic Collision Statistics

2.1.1 Basic Safety Messages and Safety Applications

Most safety applications in VANETs will rely on frequent and detailed updates of each vehicle’s whereabouts, e.g. speed, location, trajectory, etc. So, Basic Safety Messages are continuously broadcast to the sending vehicle’s neighbors at a specified rate (usually 10 messages per second, or 10hz). Safety applications receiving these messages rely on this information to predict whether a safety threat is imminent or not. According to the United States Department of Transportation the following information is contained and prioritized in basic safety messages:(Cronin, n.d.):

High Priority

- Position
- Timestamp
- Speed and heading
- Acceleration
- Brake system status
- Vehicle size
- Recent braking
- Path prediction
- Throttle position
- Vehicle mass
- Trailer weight
- Vehicle type
- Vehicle description

Medium Priority

- Steering wheel angle
- Positional accuracy
- ABS, traction status
- Stability control
- Differential GPS
- Lights status
- Wiper status
- Brake level
- Coefficient of friction
- Rain type
- Air temp

- Air pressure
- Vehicle identification
- Cargo weight
- GPS status

2.2 Terminology

BSM - Basic Safety Message. This is a message broadcasted by vehicles to announce their position, trajectory, speed, acceleration, etc. to other vehicles within receiving range of the message. The purpose of these messages is to aid safety applications, which use the information in the BSMs to determine whether a safety risk is at hand.

ITS - Intelligent Transportation Systems. Intelligent transportation systems (Smith, 2015) are applications which provide services in order to make transportation systems 'smart'. There is a wide range of potential uses for ITS, ranging from safety critical applications such as collision warnings, to minimizing traffic congestion and parking and toll collection services (Qureshi & Abdullah, 2013). For example, in Windsor, Ontario, Transit Windsor has implemented an ITS service which allows bus riders to track the location of their bus in real time, providing more accurate predictions of arrival time ("Intelligent Transportation System (ITS)," n.d.). VANETs are another example of an ITS service.

DSRC - Dedicated Short-Range Communications. These are short-range wireless communication channels dedicated to automotive use, and standards and protocols that go along with them. In the United States, the Federal Communications Commission (FCC) dedicated 75Mhz of spectrum on the 5.9Ghz band solely for ITS use ("FCC Allocates Spectrum 5.9 GHz Range for Intelligent Transportation Systems Uses," n.d.).

DCC - Decentralised Congestion Control. A congestion control technique that operates solely on each vehicle in the network, involving no use of external entities for scheduling or calculations such as RSUs.

MAC - Medium Access Control. Sublayer of the protocol stack that controls access to the medium via hardware. In VANETs it is a wireless transmission medium.

V2V - Vehicle-to-Vehicle Communication. Communication between vehicles in an ITS. These can be in the form of BSMs or packets sent for non-safety application purposes as well as other event-driven messages.

V2I - Vehicle-to-Infrastructure Communication. Communication between vehicles and transportation infrastructure fitted with DSRC technology. These could be overpasses signaling their clearance height, road signs advertising the speed limit, traffic lights alerting potential violations, etc.

RSU - Roadside Unit. A type of infrastructure fitted with DSRC technology created specifically for assistance in VANETs. These can have multiple uses from safety to non-safety applications.

WAVE - Wireless Access in Vehicular Environments. 802.11p, an adjustment made to 802.11 standards to provide wireless access in vehicular environments.

2.2.1 Performance Criteria Terminology

When examining the performance of a VANET network we measure the effectiveness of the network by a variety of factors. When applying a congestion control algorithm, there are factors which we hope to have a positive impact on (such as beacon reception rate) and factors we hope to diminish (such as channel busy time). The ultimate goal of congestion control techniques is to maximise the positive performance criteria while minimising the negative performance criteria,

BER - Beacon Error Rate. This is a performance value which takes the total number of lost packets from all vehicles divided by the total number of packets sent by all vehicles. This gives a

clue as to how bad the congestion in the network is as more lost packets means more packet collisions, which indicates more overlap and congestion.

BRR - Beacon reception rate. This is a performance value which takes the total number of packets received correctly by all vehicles in the network divided by the total number of all packets sent by all vehicles in the network over a predetermined period of time.

CBR/CBT - Channel Busy Ratio/Channel Busy Time. The total amount of time each vehicle spends sensing the channel as busy (another message is being transmitted). Once the channel is sensed to be idle, messages can be transmitted. This can be represented as a scalar value (with CBT represented as total seconds each node spent in a waiting state) or a ratio (divide the total CBT by the total simulation time).

IPD - Inter Packet Delay. The amount of time in between received packets. A shorter delay is ideal as it shows the channel is achieving more full use and more updates are being received for safety applications to perform better.

Relevance - A performance criteria this thesis has added to the simulations which determines the number of packets sent from certain distances and categorizing them by relevance. More relevant messages are received by nearby vehicles, while less relevant messages are received by more distant vehicles. The relevance is determined particularly for safety applications as closer vehicles are at higher risk for causing accidents/collisions than distant vehicles. When we are limiting the number of packets sent, or the range of sent packets, it's important for the most relevant messages to be highest in volume among all received packets, and vice versa. We consider an algorithm which does not do so to perform more poorly in a safety application context.

2.3. Important/fundamental concepts

This section describes some fundamental concepts in the area of VANETs and network congestion control.

2.3.1 DSRC and WAVE Technologies

As mentioned earlier, VANETs rely on standards such as DSRC and WAVE to send and receive messages. Without standards there is no clear way to reliably and effectively communicate. In 1999, the FCC officialized its allocation of 75Mhz of spectrum on the 5.9Ghz band for the use of V2V and V2I communications, referred to as DSRC. DSRC refers to the radio spectrum itself and WAVE refers to the associated communication standards and protocols. WAVE defines enhancements to the standard 802.11(Wi-Fi) protocols (referred to as 802.11p) designed to support communication between high speed vehicles, as well as a layered architecture for packets sent in VANETs. Figure 2.2 (Orozco, Michoud, & Ramírez, 2013) visualises the WAVE architecture as a stack.

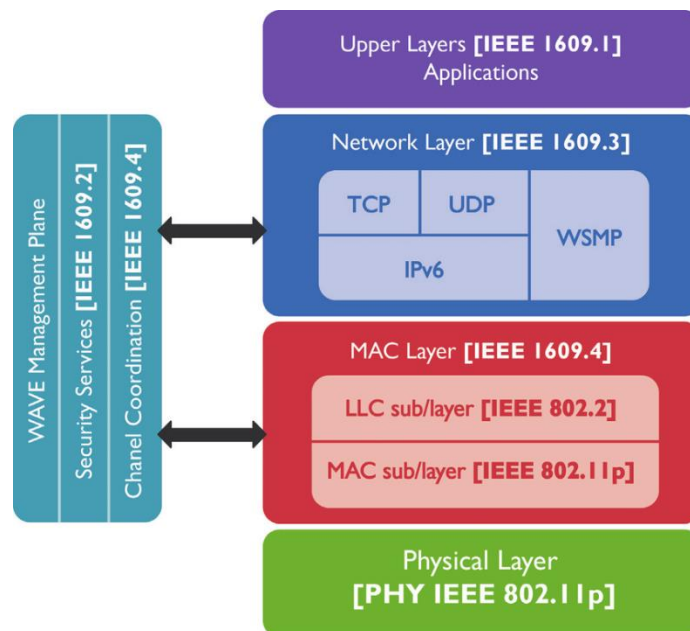

Figure 2.2 WAVE Architecture

2.3.2 Congestion and Packet Loss

It's quite clear to see how a network of close vehicles transmitting messages constantly at a high rate can quickly become congested. Packet collision happens when multiple messages are sent at the same time and overlap at a listening node. The packets are then lost at the

receiving node. As such the vehicles must listen to the medium before sending off a packet to avoid such collisions. When packet collision is happening too often, and vehicles are waiting for a long amount of time to transmit their messages, we consider the network congested.

2.3.3 Congestion Control Algorithms

Congestion control strategies can be classified as proactive or reactive. Proactive congestion control techniques are techniques which apply congestion control regardless of the state of the network. Reactive congestion control techniques wait until the network is congested before applying congestion control. A network can be considered congested when one or many of the performance criteria pass a certain threshold. DCC techniques can be reactive or proactive. DCC strategies explored to date have three main approaches. First is to alter the rate of transmissions (i.e. send fewer BSMs per second). Second is to alter the power of the transmission so that the message does not travel as far. A third approach is to adjust both in a hybrid congestion control technique. In the first approach, inter-packet delay is increased, as there is more time in between the messages being sent. In the second approach, awareness and beacon delivery rate are reduced, as fewer vehicles receive the messages. In the algorithm proposed in chapter 3 of this thesis we describe an approach that adjusts the transmission power of the vehicles.

2.4. Current Research Problems and Solutions

VANETs are an emerging technology and as such face several challenges. One area is security. Since a VANET is a network like any other, it can be attacked in similar ways as standard networks (Hasrouny, Samhat, Bassil, & Laouiti, 2017). Security and privacy are of much concern in an area where human life could possibly be on the line should a safety application not perform adequately. Research is active in this area. Other challenges exist as well, such as routing protocols and message transmission capacity. Routing is complicated by the fact that each

vehicle in the network is wirelessly broadcasting every message, so all vehicles must participate in routing and issues such as routing loops must be taken into consideration (Hasrouny, Samhat, Bassil, & Laouiti, 2017).

Transmission capacity limits affect VANETs as well, especially in the area of interference. In high density scenarios such as traffic jams, interference can cause MAC issues (Hasrouny, Samhat, Bassil, & Laouiti, 2017). This is the problem area that this thesis aims to mitigate. It has been shown that traditional models of capacity do not work in VANETs or any ad hoc network, and there is currently no framework to find the fundamental capacity of a VANET (Andrews et al., 2008). As such, there are a variety of approaches to determining whether a VANET is at or beyond capacity, and causing congestion and packet loss such as measurement based detection, event-driven detection, and mac blocking detection (Singh & Singh, 2018).

Other research challenges include those surrounding simulation techniques for testing VANET applications and algorithms. A realistic simulation with realistic parameters and mobility are necessary for determining the effectiveness of congestion control algorithms and other applications in VANETs (Cloudin & Kumar, 2017). Many proposed algorithms tested their performance using a limited version of a VANET (no non-safety applications running, no non-BSM broadcasts being sent, etc.) so it cannot be certain that their results would reflect a real-life scenario.

As for congestion control techniques, it was mentioned earlier that there are two main methods of reducing congestion in a DCC algorithm - power and rate control. Each of these has its own limitations. With rate control, sending fewer packets results in a loss of awareness in the network. That is to say that fewer packets are received from each vehicle, making the update of their status information less timely with more delay. Delays in safety applications might have serious consequences. On the other hand, sending at high rates can result in higher awareness, but also a higher chance of collision between sent packets. For power control, sending at a lower power results in more distant vehicles not receiving packets from the sending vehicle. This also

results in a loss of awareness as these distant vehicles are not aware of those outside of its receiving range. Transmitting at a high rate on the other hand can cause significant overlap between transmitting vehicles and cause more collision between sent packets. Most techniques aim to minimize the negative effects of applying DCC algorithms on the network while maximising the positive effects. However, negative performance impacts can usually still be seen after applying DCC to the VANETs.

2.5. Literature review

This section describes some of the prominent research and schematic solutions to congestion control in VANETs. Researchers who develop algorithms to assist in congestion control of VANETS focus on optimising performance while maintaining little overhead in order not to delay BSMs for too long. Most of the articles reviewed propose decentralized congestion control (DCC) techniques for VANET. A DCC approach involves no reliance on external RSUs or central processing hubs, allowing for less overhead and delay, and a self-contained, on-the-fly technique. There are two main approaches in DCC techniques: transmission power adjustment and transmission rate adjustment. Algorithms based on rate control adjust how many packets are sent over a given time. Algorithms based on power control adjust the power of the transmission which affects the range of vehicles each packet transmission can reach. However, there are other approaches such as those based on CSMA/CA, packet priority and scheduling, and even some centralized techniques based on machine learning algorithms. Of course, many approaches combine many of these methods and can be referred to as hybrid algorithms.

An early work in this area includes “Distributed Fair Transmit Power Adjustment for Vehicular Ad Hoc Networks” (D-FPAV) (Torrent-Moreno, Santi, & Hartenstein, 2006) in which the transmission power of each vehicle is calculated in order to maximise the minimum transmission power used in the network while remaining under the Maximum Beaconing Load (MBL). This

algorithm achieved strict fairness in terms of channel busy time but slightly reduced BER to prioritize event-driven packet delivery.

In “On the Congestion Control Within VANET” (Bouassida & Shawky, 2008) the authors presented a congestion control algorithm based on “dynamic priorities-based scheduling,” giving messages priority based on measurable factors such as node speed, message utility, and message validity. This approach validated the message queueing algorithm, however it was not tested in a network traffic simulation to see the improvement of the performance of the network. Later work involved some of the most popular algorithms in the area of VANET congestion control, which are still currently used as threshold for more recent DCC algorithm performance. Such works include “A robust congestion control scheme for fast and reliable dissemination of safety messages in VANETs” (Djahel & Ghamri-Doudane, 2012) which proposed a phase-based algorithm which worked in three stages: message priority assignment, congestion detection, and power/rate control. This approach had the advantage of only activating congestion control when congestion is detected, thereby improving performance of ITS.

Another paper “LIMERIC: A Linear Adaptive Message Rate Algorithm for DSRC Congestion Control” (Bansal, Kenney, & Rohrs, 2013) proposed an algorithm which adjusted transmission rate in order to achieve the desired channel usage to optimally achieve fair use of the network, which helped reduce congestion at the cost of reducing awareness (with fewer packets being sent by each vehicle). Researchers directly extended LIMERIC to develop “EMBARC: Error Model Based Adaptive Rate Control for Vehicle-to-vehicle Communications”(Bansal, Lu, Kenney, & Poellabauer, 2013) which included a scheduling algorithm based on vehicle movement. Simulations showed the vehicle movement tracking was accurate but again, reducing message rate sacrifices network awareness. Another popular and high performing algorithm in this area is “BRAEVE: Stable and adaptive BSM rate control over IEEE802.11p vehicular networks” (Ogura, Katto, & Takai, 2013) which adjusts the BSM transmission rate based on number of neighboring vehicles in range of the transmitting vehicle. This strategy worked for dynamic traffic scenarios,

however it was noted that more severe traffic would need more sophisticated methods of approximating neighboring vehicle density.

An interesting work proposed in this field was also “Joint Congestion Control Strategy During V2V Communication Among Authentic Vehicles in VANET” (Mitra & Mondal, 2014) which proposed a new approach of using RSUs to jointly work with authentic vehicles in the network in order to adapt both power and rate of transmissions. Although effective, this cannot be considered a DCC approach since it involves the use of RSUs. Another work in this area is “Power Adjustment Based Congestion Control in Vehicular Ad-hoc Networks” (Lei, Liu, Wang, Wang, & Wang, 2014) which proposed a new, iterative method of transmission power adaptation while tracking channel load and transmission delays. Transmission powers used in the simulations to test this algorithm were quite high, giving messages more range and a higher chance to collide.

Some current work reviewed in this survey includes “Centralized and Localized Data Congestion Control Strategy for Vehicular Ad Hoc Networks Using a Machine Learning Clustering Algorithm” (Taherkhani & Pierre, 2016) which is very different from most of the algorithms reviewed as it proposes a centralised approach in which three RSUs perform scheduling at red light intersections. However, as a centralised and specialized approach it has limited relevance to generic traffic models. Another unique algorithm in this area is “Pro-AODV (Proactive AODV): Simple modifications to AODV for proactively minimizing congestion in VANETs”, which proposed a congestion control approach in the context of the AODV routing protocol for use in a VANET by reducing the number of path request messages. (Kabir, Nurain, & Kabir, 2015). This algorithm had a better BER than traditional AODV approaches with no modifications, however it was only tested in the context of using the AODV routing protocol. “VANET congestion control approach using empathy” Proposed a VANET congestion control approach using empathy and probabilistic models for node rejection rates. (Idrissi, Laghrissi, Retal, & Rehioui, 2015). The “empathy” described in this algorithm is the determination of whether certain channels were or weren’t congested and adjusting the sending of messages accordingly. This approach was found to be

effective in a dense network, but not in a sparse network (performance was hindered). Additionally, there's "Decentralized congestion control algorithm for vehicular networks using oscillating transmission power" (Willis, Jaekel, & Saini, 2017) which is a power adjustment algorithm that involves each vehicle alternating between two predetermined transmission powers. This algorithm reduced unnecessary noise in the distant network at the cost of increasing IPD at further distances.

Two published algorithms are of particular interest to this thesis as the work being proposed is based directly on them as stated in chapter 3. One algorithm published recently is "An Adaptive Power Level Control Algorithm for DSRC Congestion Control" (Joseph, Liu, & Jaekel, 2018) which adjusts each vehicle's transmission power based on its own speed. The faster a vehicle was traveling, the higher the transmission power used, while maintaining a constant transmission rate of 10hz. This was done in three speed windows: low, medium, and high. It was found to be more effective than using no congestion control and performed slightly better than the oscillating algorithm described in (Willis, Jaekel, & Saini, 2017) in terms of IPD and BER.

The other algorithm is "Traffic Density Based Distributed Congestion Control Strategy for Vehicular Communication" (Akinlade, Saini, Liu, & Jaekel, 2019). In this publication, an algorithm was proposed that adjusts each vehicle's power based on the number of vehicles in the network area while keeping the transmission rate at 10 hz. The higher the number of vehicles, the lower the transmission power used, and vice versa. It was found to slightly out-perform the speed-based algorithm defined in (Joseph, Liu, & Jaekel, 2018) in terms of BRR, and IPD. However, this approach relied on the assumption that each vehicle knows how many vehicles exist in the overall network, which may not be so easy to achieve realistically.

Work is still actively being done in the area of VANET congestion control. Since VANETs are not yet fully implemented, there is much conceptualizing and most algorithms' effectiveness is measured through the use of network simulation software.

Chapter 3 Proposed Algorithm

3.1 Introduction

Congestion control techniques aim to improve performance in various areas such as BER, BRR, CBT, IPD, and in our case we also add Relevance. Applying a DCC algorithm to the network, we make sacrifices in some areas (such as BRR) to improve performance in other areas (such as BER). As loss in performance of IPD and BRR are expected when applying a DCC, we tend to look and performance criteria that would help safety applications perform better. Relevance is one such criteria. In our interpretation of the results, it is more important that more BSMs are received from closer distances. This is preferred over receiving messages frequently from further distances, as vehicles that are far away do not pose as much of a threat. If more relevant messages are received at the cost of an increase of IPD at far distances, we consider this an improvement in safety application performance.

3.2 High-level Overview

The proposed algorithm works in three stages: vehicle speed assessment, transmission power calculation, and power assignment.

3.2.1 Speed assessment

Vehicles' speed varies throughout their journey. Obstacles in the road, traffic lights and signs, passing, and many other variables can affect speed. The proposed algorithm runs on the premise that vehicles' speed increases and decreases in accordance with traffic density. If the vehicle is moving at a high speed, it is more likely that traffic is sparse, and vice versa. The instantaneous speed of each vehicle is taken 10 times per second and used to do the next step of the algorithm.

3.2.2 Transmission Power Calculation

The desired transmission power for each vehicle is calculated based on the vehicle speed acquired in the first step of the algorithm. A higher speed means a higher transmission power. The direct relationship between vehicle speed and transmission power used is based on an approximation of network density from the Ontario Ministry of Transportation's recommended "2 seconds of space" (Government of Ontario, n.d.). Our calculation assumes that approximately "2 seconds of space" exist between vehicles traveling at their respective speeds. "2 seconds of space" means the amount of space that would be covered by the vehicle, at its current speed, in 2 seconds. Essentially, we approximate this amount of space by doubling the vehicle's speed in meters per second. We then multiply this amount of space by a "target range", which is the number of vehicles ahead and behind that we wish to reach with our transmission. This gives us the basic distance we wish to cover with our transmission. Of course, this is an idealized scenario, as many different factors can affect transmission range, but this is something to explore in future work.

3.2.3 Power Assignment

Power assignment involves a quick calculation based on the free-space path loss formula for radio signals. Again, this is an idealized scenario where we don't worry about antenna gains or losses or other factors that could affect signal transmission range. Once we have the desired transmission power calculated, it is compared to a predefined maximum and minimum desired transmission power. We choose a min and max for the event where a car may be traveling too slow (such as in a traffic jam) and a max to avoid signals from traveling too far. The min and max also help keep consistency when comparing between other DCC algorithms. If the calculated transmission power is less than the minimum, the minimum is used instead. If it is greater than

the maximum, the maximum is used instead. Otherwise the newly calculated transmission power is set as the new transmission power for the next broadcast. After this step, the algorithm repeats.

3.3 Proposed Algorithm

The proposed algorithm is described in Figure 3.1 below.

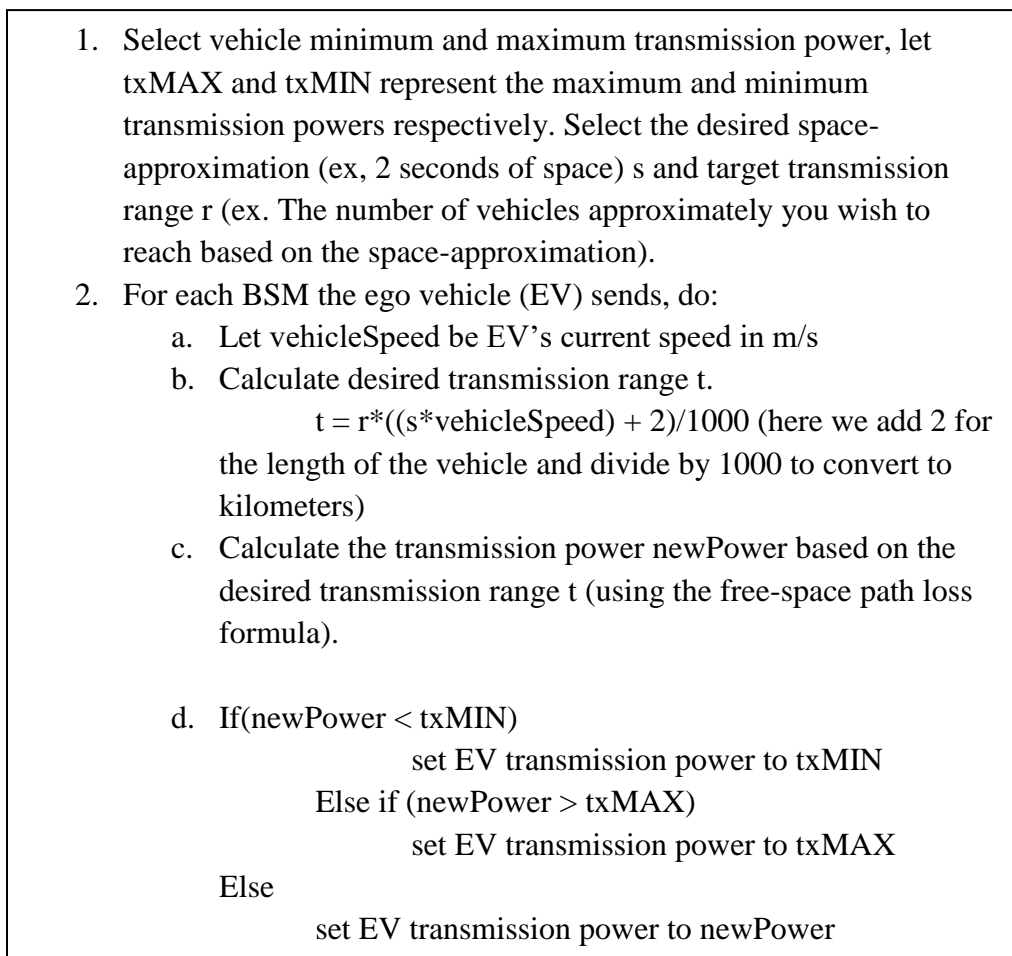

Figure 3.1 Proposed DCC algorithm

The algorithm begins by setting input parameters as in step (1). These include 4 parameters: maximum transmission power, minimum transmission power, speed-density approximation, and target range. The maximum transmission power, txMAX, is the upper limit to the transmission range. The minimum transmission power, txMIN is the lower limit to the

transmission power. We set max and mins in order to account for situations where cars could be travelling too fast and have too high of a transmission power, or too slow and have too small of a transmission power (for example, a slow-moving traffic jam). The speed-density approximation is the approximation of how many “seconds of space” exist in between each vehicle during driving time. The target range is the number of vehicles ahead we hope for each transmission to reach (assuming a density approximation of s).

In step (2a) we get the current vehicle’s (we call this the “ego vehicle” or EV) speed. The algorithm is repeatedly and concurrently running on all vehicles in the network. Using EV’s speed we can calculate the target transmission range, t .

In step (2b) We calculate t as follows:

$$t = r * ((s * vehicleSpeed) + 2)/1000$$

We add 2 to the amount of space between vehicles to account for the length of the cars themselves (which is set in simulation parameters). Since the speed is retrieved in meters per second, we divide the result by 1000 to get the target range in kilometers.

In step (2c) we calculate the new transmission power needed for transmitting a distance of t . We use an idealized scenario where only the pathloss affects the transmission reception range. Pathloss is transmission power (tx) minus receiver sensitivity (rx). In our simulations, the receiver sensitivity is the default -89dBm. We use the free-space path loss formula to calculate the required transmission power:

$$Transmission\ Distance\ (km) = 10^{(pathloss - 32.44 - 20(\log_{10}(transmission\ frequency)))/20}$$

Since $pathloss = tx - rx$ and our transmission frequency is 5890MHz according to DSRC standards, we can substitute these known values and isolate for tx :

$$tx(dBm) = 20\log_{10}(t) + 20\log_{10}(5980) - 56.56$$

Since the software API receives the transmission power update in milliwatts (mW) we convert our result to this unit using the following formula:

$$power (mW) = 10^{power(dBm)/10}$$

In step (2d) we determine whether the newly calculated power newPower is less than txMIN, greater than txMAX, or in between and set the transmission to txMIN, txMax or newPower respectively.

This concludes the algorithm and is repeated every time the EV sends a new packet (as described in step (2)) which occurs 10 times per second as is the typical maximum transmission rate used by most DCC algorithms.

The flow of the algorithm is visualised in Figure 3.2 below.

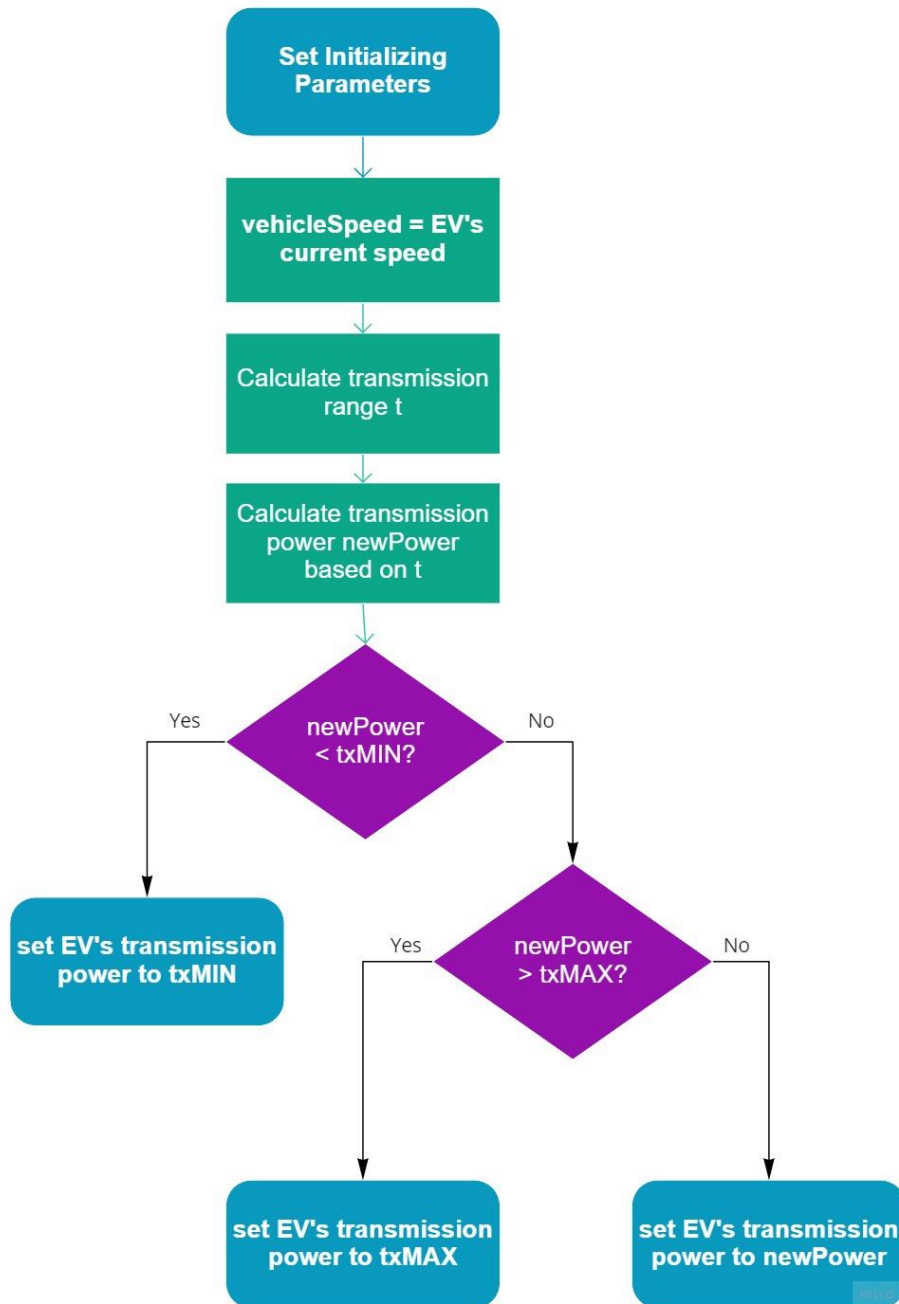

Figure 3.2 Proposed algorithm flow chart

3.3.1 Example

Suppose the EV is traveling at 80km/hr. 80km/hr is approximately 22.22 m/s. 2 seconds of space is:

$$22.22m/s * 2s = 44.44m$$

Now that we've approximated how much space might exist between each vehicle, we calculate the total amount of space we wish to reach. Suppose in this example, we use $r = 5$.

$$t = r * ((44.44) + 2)/1000$$

$$t = 5 * (44.44 + 2)/1000$$

$$t = 232.2/1000$$

$$t = 0.2322km$$

So, our target range t is 0.2322km. Next, we calculate the required transmission power in dBm using the free space path loss formula:

$$tx(dBm) = 20\log_{10}(t) + 20\log_{10}(5980) - 56.56$$

$$tx(dBm) = 20\log_{10}(0.2322) + 20\log_{10}(5980) - 56.56$$

$$tx(dBm) = 62.85 - 56.56$$

$$tx(dBm) = 6.29$$

Since the API used in the simulations receives the power update in mW, we translate dBm to mW:

$$power(mW) = 10^{power(dBm)/10}$$

$$power (mW) = 10^{6.29/10}$$

$$power (mW) = 10^{0.629}$$

$$power (mW) = 4.26$$

Now that we have the power in the correct format for the simulation API, we check its value against our predetermined minimum and maximum. Using a minimum transmission power of 2mW and a maximum of 10mW we can determine 4.26mW as an acceptable power to use as it falls within the range of the minimum and maximum. The next BSM sent by EV will be sent with a transmission power of 4.26mW.

3.4 How the proposed algorithm differs from prior work

This algorithm is particularly based on the works of (Joseph, Liu, & Jaekel, 2018) and (Akinlade, Saini, Liu, & Jaekel, 2019). In (Joseph, Liu, & Jaekel, 2018) a transmission power is chosen for each vehicle based on speed windows, i.e. certain transmission powers are chosen for a certain range of speed. A low transmission power was used for “low” speeds, a medium transmission power was used for “medium speeds, and a high transmission power was used for “high” speeds. The ranges for the speed windows were chosen arbitrarily and found to basically work. There is no reasoning behind the choice of transmission power for each speed window. In (Akinlade, Saini, Liu, & Jaekel, 2019), a transmission power is chosen for each vehicle based on how many vehicles exist in the network. A high power is used for a “low” quantity of vehicles, a medium power is used for a “medium” quantity of vehicles, and a low power is used for a “high” quantity of vehicles. The choice of how many vehicles constitutes a high, medium or low quantity was also arbitrary as with the speed windows in (Joseph, Liu, & Jaekel, 2018).

The proposed approach, while based directly on the aforementioned techniques, differs in the sense that it provides a reasoning for each transmission power used. Rather than arbitrarily

choosing a transmission power based on speed, a precise calculation with exact reasoning is used. Additionally, it does not use any external information about the network such as quantity of vehicles. The quantity of vehicles in the network is difficult to calculate in real life scenarios, since it's hard to pinpoint where the "beginning" and "end" of the VANET area is, while in the simulations, there is only a segment of a road being used.

Chapter 4 Simulations and Results

4.1 Simulation

It is difficult to execute experiments to test the effectiveness of DCC algorithms in a real-world scenario due to the expense, equipment and resources needed and safety concerns. Therefore, we use simulation software to execute such experiments on a digital scale. This is a much cheaper and safer method of testing the algorithms and analyzing the results. For our experiments, we used three software in unison. They consist of a network simulator, a traffic simulator, and a communication software for interaction between the two. The traffic simulator used was Simulation of Urban Mobility (SUMO) (“SUMO - Simulation of Urban Mobility,” n.d.). SUMO is a free and open source microscopic simulation software implemented in C++ which uses portable API libraries and can be used to simulate vehicles, pedestrians, public transport, etc. The network simulator used was OMNet++ (“OMNeT++ Discrete Event Simulator,” n.d.) which is a modular component-based C++ simulation library and framework. Tying these two software packages together is VEINS (“Veins,” n.d.) which is a framework that includes models for making traffic simulations realistic and providing communication between SUMO and OMNet++ by means of the Traffic Control Interface (TraCI). Veins provides communication between SUMO and OMNet++ by means of a TCP socket connection. Figure 4.1 (“Veins,” n.d.) provides a graphical depiction of how all three of the simulation software work together.

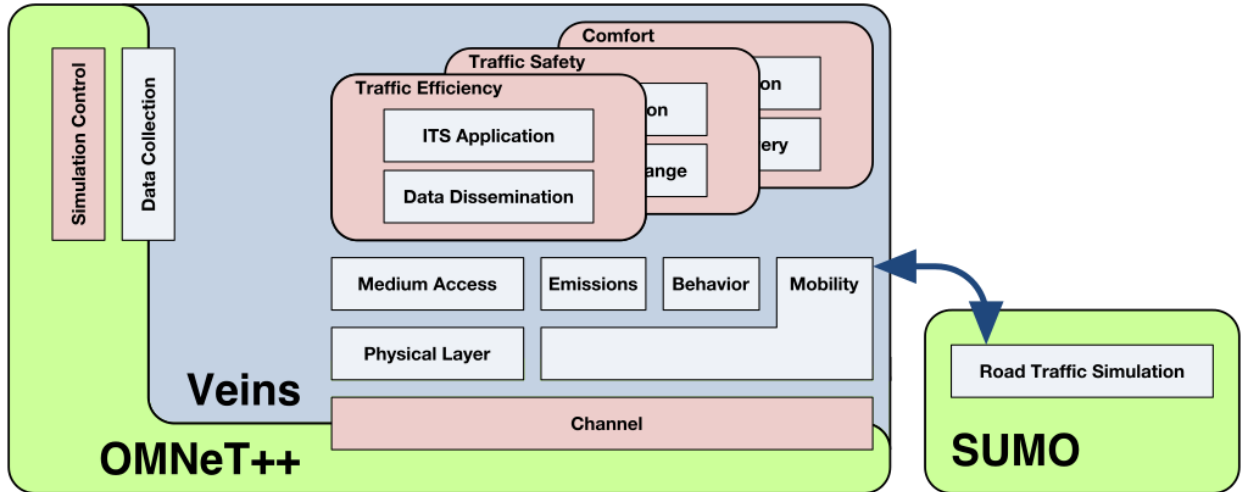

Figure 4.1 Graphical depiction of simulation software setup

4.1.1 Simulation Setup

There were three traffic scenarios used to test the performance of the proposed algorithm.

- A six-lane highway composed of three lanes in either direction, with a speed limit of 80km/hr. This simulation was run for 60 seconds.
- A twelve-lane highway composed of six lanes in either direction, with a speed limit of 80km/hr. This simulation was run for 60 seconds.
- A twelve-lane highway composed of six lanes in either direction, with a speed limit of 50km/hr. This simulation was run for 70 seconds, to give the slower moving vehicles more time to move along the road.

The road in each scenario consisted of a 900m long horizontal stretch of road. Traffic was split evenly between east-bound traffic and west-bound traffic. In each traffic scenario, the following parameters remained consistent:

Table 4.1 Simulation parameters for each highway scenario

Parameter	6-lane highway	12-lane highway (fast)	12-lane highway (slow)
Simulation duration	60 seconds	60 seconds	70 seconds
Bitrate	6Mbps	6Mbps	6Mbps
Sensitivity	-89dBm	-89dBm	-89dBm
Transmission rate	10 Hz (10 packets per second)	10 Hz (10 packets per second)	10 Hz (10 packets per second)
BSM size	250 Bytes	250 Bytes	250 Bytes
Road length	900m	900m	900m
Lanes	6 (3 in each direction)	12 (6 in each direction)	12 (6 in each direction)
Max vehicle speed	80km/hr	80km/hr	50km/hr
Vehicle length	2m	2m	2m
Total number of generated vehicles	148	316	309

Each traffic scenario was run with six different DCC algorithms:

- A general approach with no DCC, labeled as “General” in result graphs.
- The Oscillating algorithm proposed in (Willis, Jaekel, & Saini, 2017), labeled as “OSC” in result graphs.
- The speed-based algorithm proposed in (Joseph, Liu, & Jaekel, 2018), labeled as “Adaptive-Speed” in result graphs.
- The density-based algorithm proposed in (Akinlade, Saini, Liu, & Jaekel, 2019), labeled as “Adaptive-Density” in result graphs.

- The algorithm proposed in chapter 3 of this thesis, with target range parameter set to 4, labelled as “Adaptive speed-density, $r = 4$ ” in result graphs.
- The algorithm proposed in chapter 3 of this thesis, with target range parameter set to 5, labelled as “Adaptive speed-density, $r = 5$ ” in result graphs.

Throughout all runs of each simulation, vehicles only transmitted BSMs as messages consistently and continuously throughout the duration of the simulation. Each BSM contained important information such as:

- Sender ID
- Sender Speed
- Sender Position

The information contained in each BSM such as position, was used to calculate results (such as distance from sender).

Each vehicle drove in a straight line from the beginning to the end of the road (respective of where they started). Vehicles were consistently generated every 0.1 seconds in any lane with space availability.

4.2 Simulation Results

Each simulation gathered result data for the analysis and examination of the performance of each algorithm. Such data included total packets sent, total packets received, total packets lost, IPD, CBT, and relevance. The details of each result is discussed below.

4.2.3 Packets Sent

Figures 4.2, 4.3 and 4.4 show the total number of packets sent by all vehicles in the 6-lane, 12-lane fast, and 12-lane slow simulations respectively. The number of packets sent is identical for all DCC algorithms used, which is expected since all transmit messages at the same rate (10 packets per second, or 10 hz) and due to the deterministic nature of the SUMO traffic

simulator. We notice that the fewest packets were sent in the 6-lane simulation, and the most packets were sent in the 12-lane slow simulation.

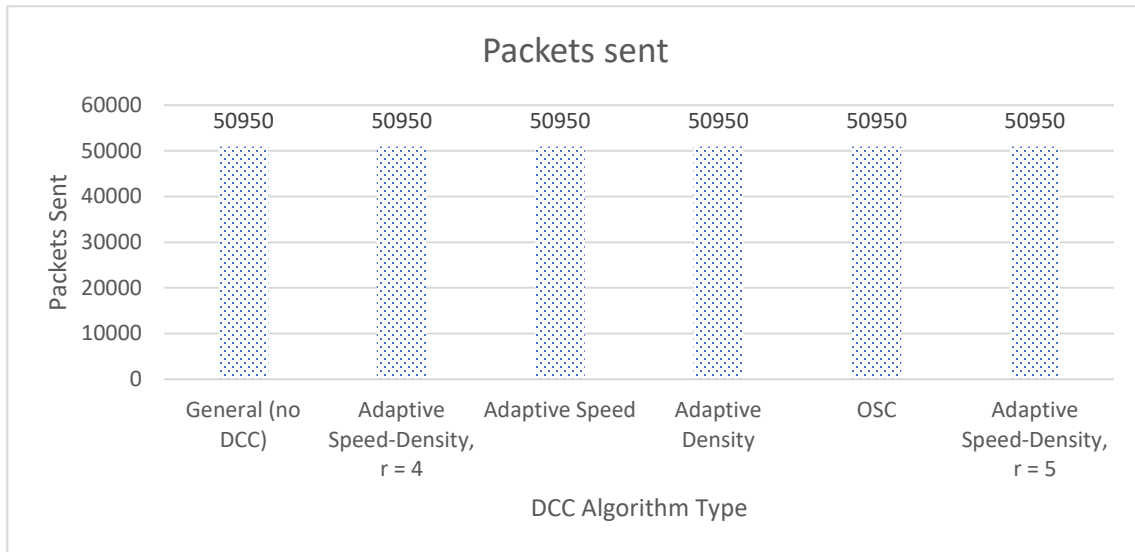

Figure 4.2 Packets sent in the six-lane highway simulation

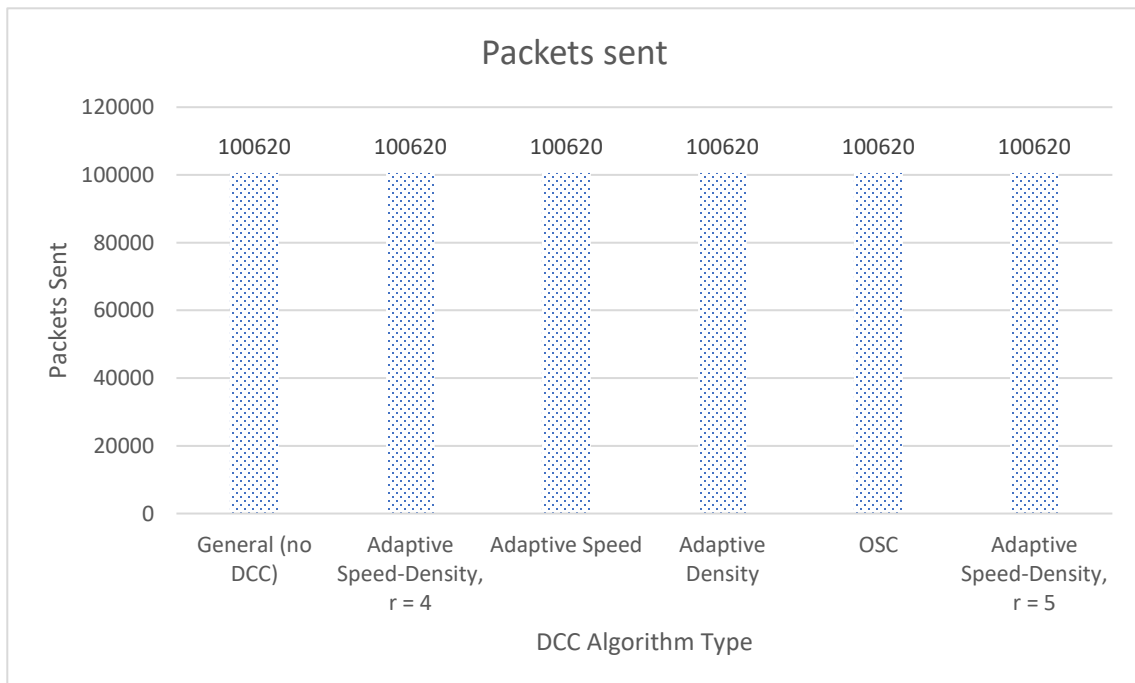

Figure 4.3 Packets sent in the 12-lanes fast highway simulation

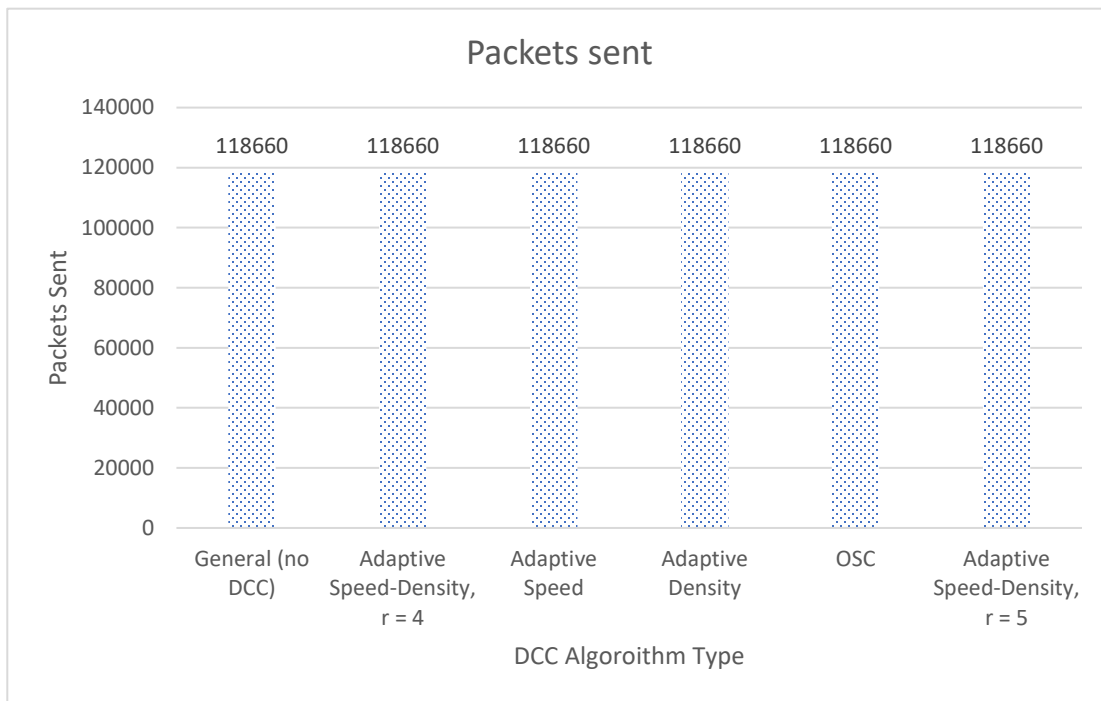

Figure 4.4 Packets sent in the 12-lanes slow highway simulation

4.2.4 Packets Received

The amount of received packets gives a general idea of how much awareness is in the algorithm. This is the sum of all packets received by all vehicles for the duration of the simulation. We can see that using no DCC result in the highest amount of received packets, while the DCC algorithms all performed relatively similar in this area. However, this does not mean that using no DCC is better than using DCC. Simply receiving more packets does not necessarily translate to better performance of safety applications. It simply means that each beacon was transmitted further, and therefore received by more distant vehicles than the DCC algorithms, which were limiting the transmission range based on various factors. In figures 4.5, 4.6, and 4.7, we can see that all DCC algorithms received fewer packets than the general approach, due to limiting the transmission power of messages. The DCC algorithms performed relatively similarly, with the

speed-based algorithm having the highest amount of received packets of the bunch. The error bars in the graphs represent the 95% confidence intervals and seem to remain fairly similar among all algorithms throughout the simulations.

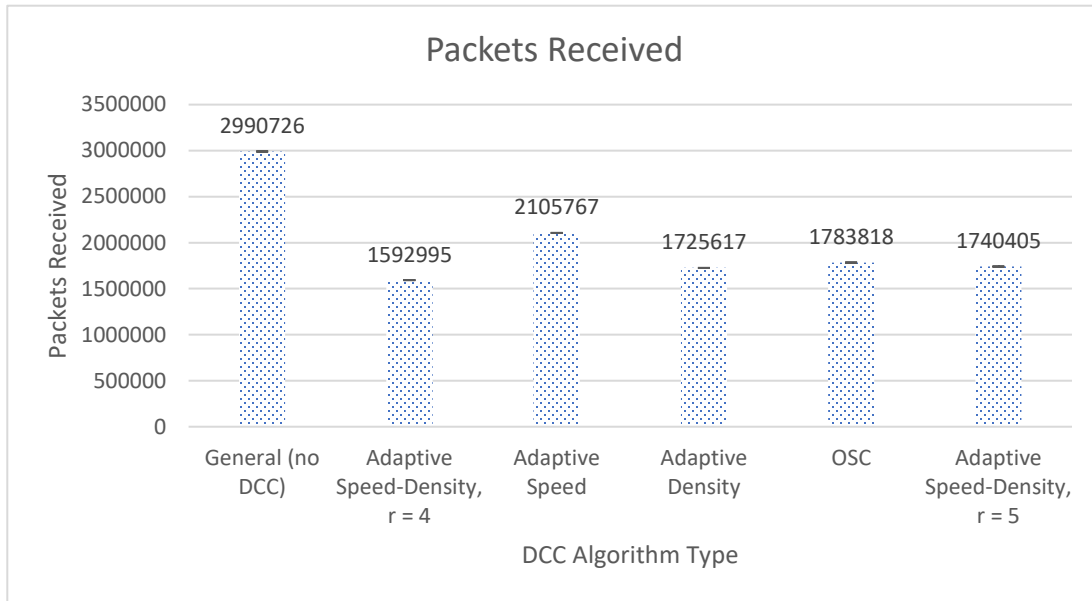

Figure 4.5 Packets received in the 6-lane highway simulation¹

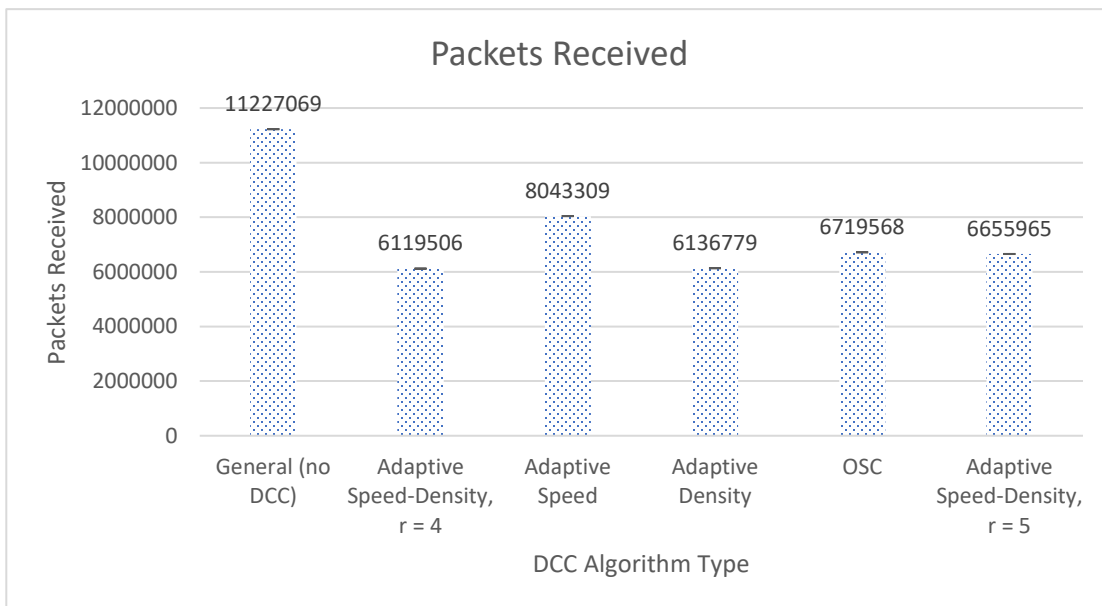

Figure 4.6 Packets received in the 12-lane fast highway simulation²

¹ 95% confidence values from left to right: 792.49, 649.50, 712.35, 572.95, 655.98, 700.37

² 95% confidence values from left to right: 1081.41, 788.79, 954.17, 819.53, 798.90, 905.03.

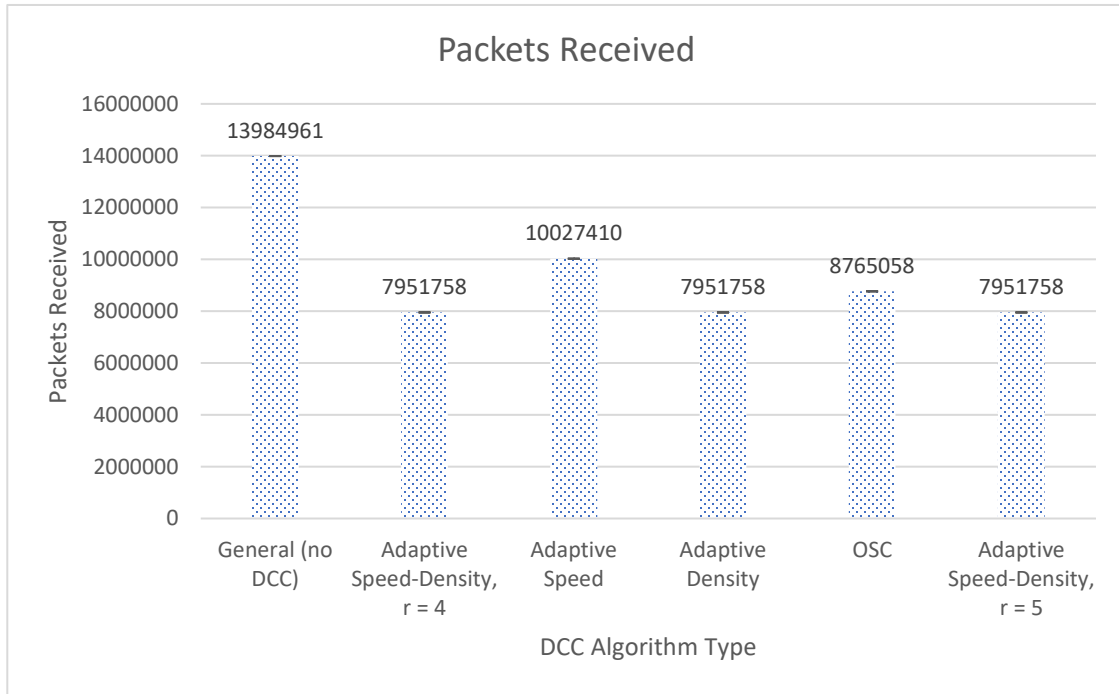

Figure 4.7 Packets received in the 12-lane slow highway simulation³

4.2.3 Packets Lost

Measuring packet loss gives us a general idea of how congested the network is. As mentioned earlier, packet loss occurs with packet collisions, which happens more often in a congested network than a non-congested network. A high amount of packet loss can affect performance of safety applications. Observing figure 4.8, we see that the general approach using no DCC results in the highest amount of packet loss, while DCC algorithms can reduce the amount of packet loss significantly. We observe that the lowest amount of packet loss occurs in the density-based algorithm, followed by OSC, the proposed algorithm at $r = 4$, the speed-based algorithm, then the proposed algorithm at $r = 5$. However, in figures 4.9 and 4.10 we can see that

³ 95% confidence values from left to right: 295.51, 808.50, 439.89, 808.50, 625.54, 808.50.

the proposed algorithm begins to perform better, as the stress of the network increases, and performs similarly as the density-based approach. The 95% confidence values show a sizable difference between the general, no DCC approach and the rest of the DCC algorithms, meaning the general approach suffers from more volatile individual values among the vehicles.

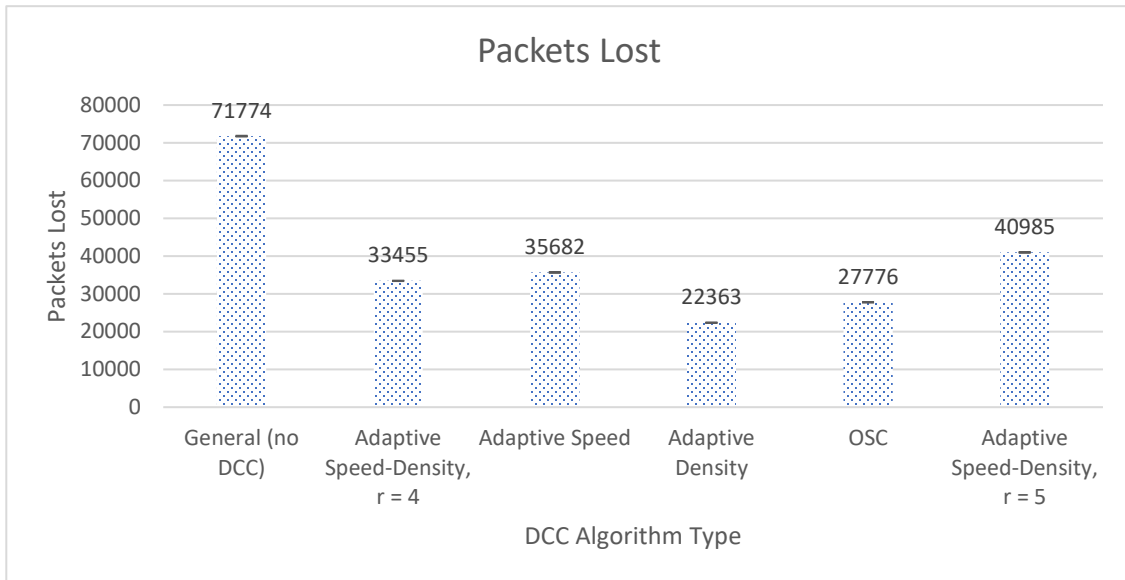

Figure 4.8 Packets lost in the 6-lane highway simulation⁴

⁴ 95% confidence values from left to right: 96.88, 51.40, 43.25, 48.52, 31.00, 51.27

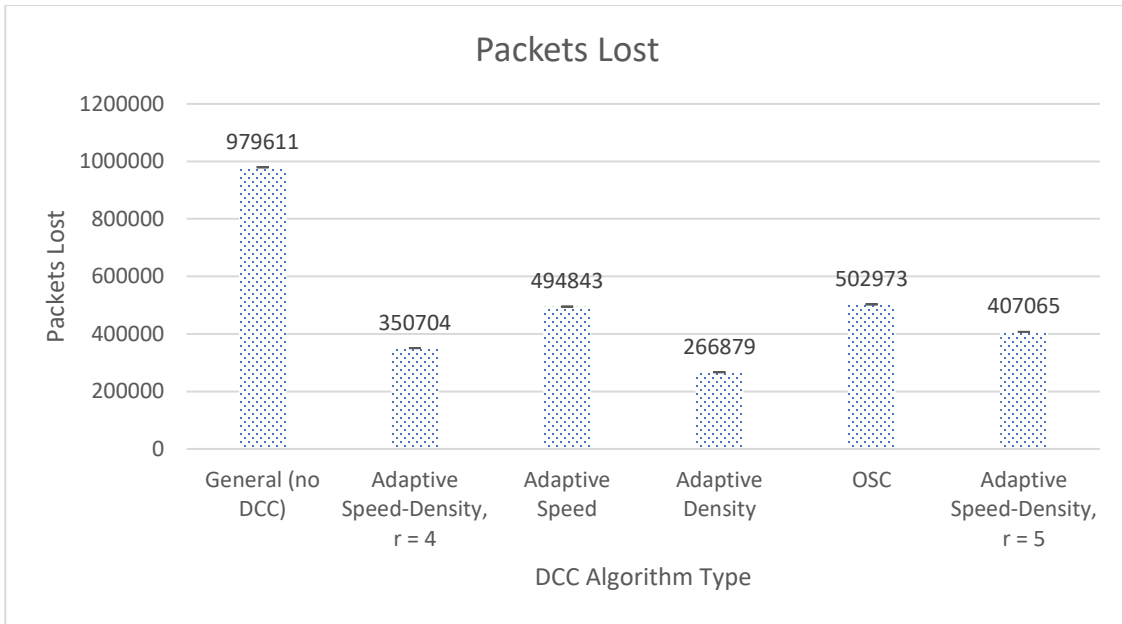

Figure 4.9 Packets lost in the 12-lane fast highway simulation⁵

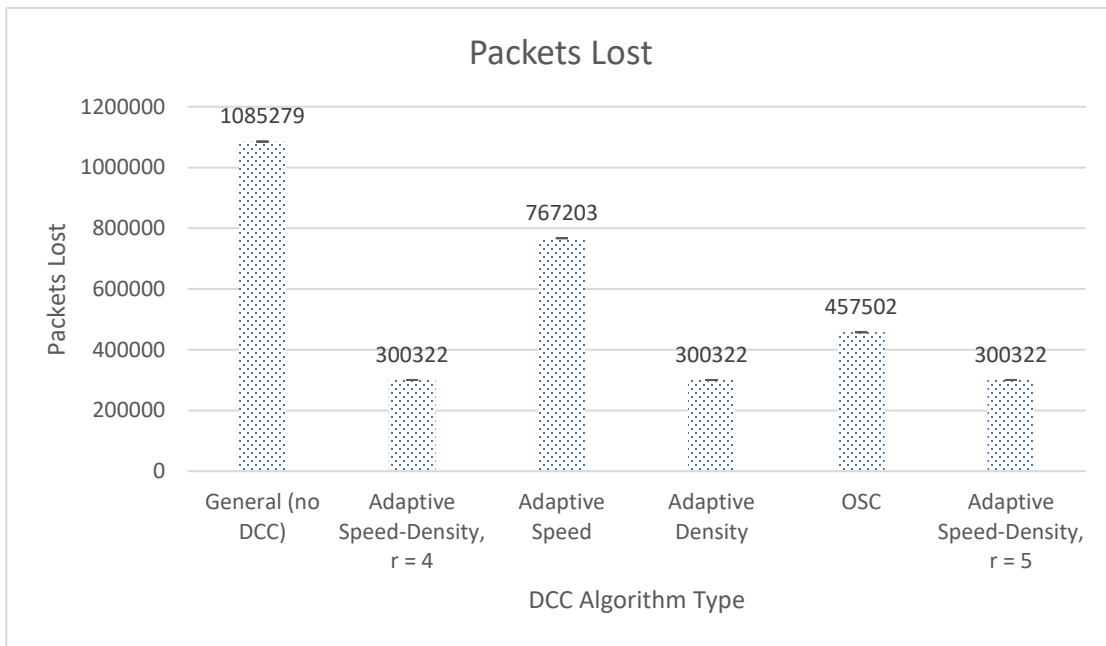

Figure 4.10 Packets lost in the 12-lane slow highway simulation⁶

⁵ 95% confidence values from left to right: 300.65, 164.93, 143.17, 100.28, 184.10, 119.04

⁶ 95% confidence values from left to right: 88.85, 76.37, 85.98, 76.37, 117.60, 76.37

4.2.4 Beacon Reception Rate

BRR is the ratio of packets received to packets sent in the network. Without question, a high amount of received packets in the network directly translates to a high BRR. As we can see in figures 4.11, 4.12 and 4.13, the general approach of using no DCC has the highest BRR. As mentioned earlier, this does not necessarily translate to a higher performing safety application, since it usually also means a higher BER as well, as we will see in the next section. BRR is a secondary performance measure we look at after all other things are considered. Among DCC approaches, there is a smaller BRR, but they all have similar performance, with the speed-based approach slightly higher than the rest.

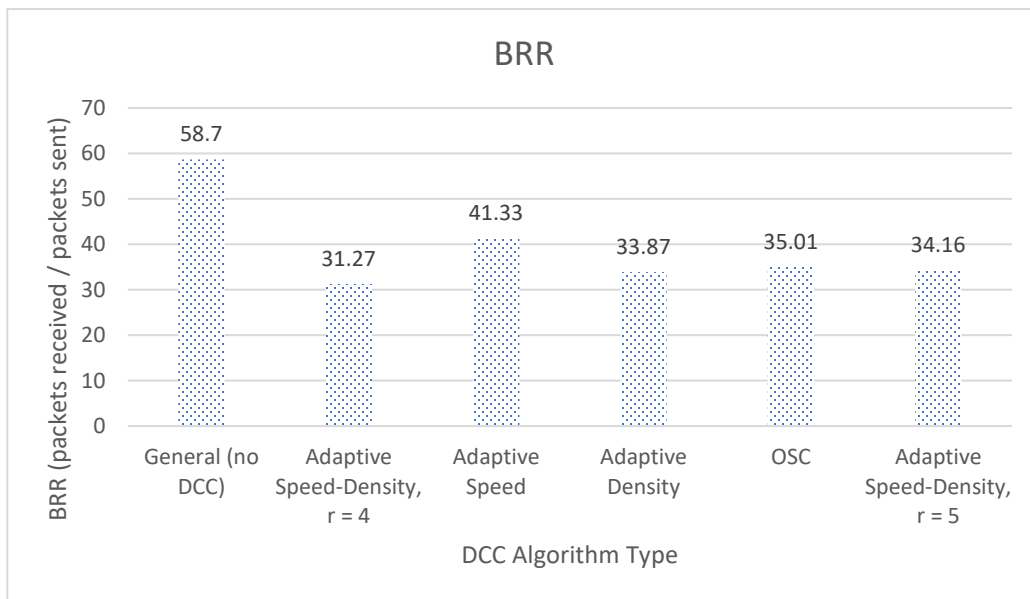

Figure 4.11 BRR in the 6-lane highway simulation

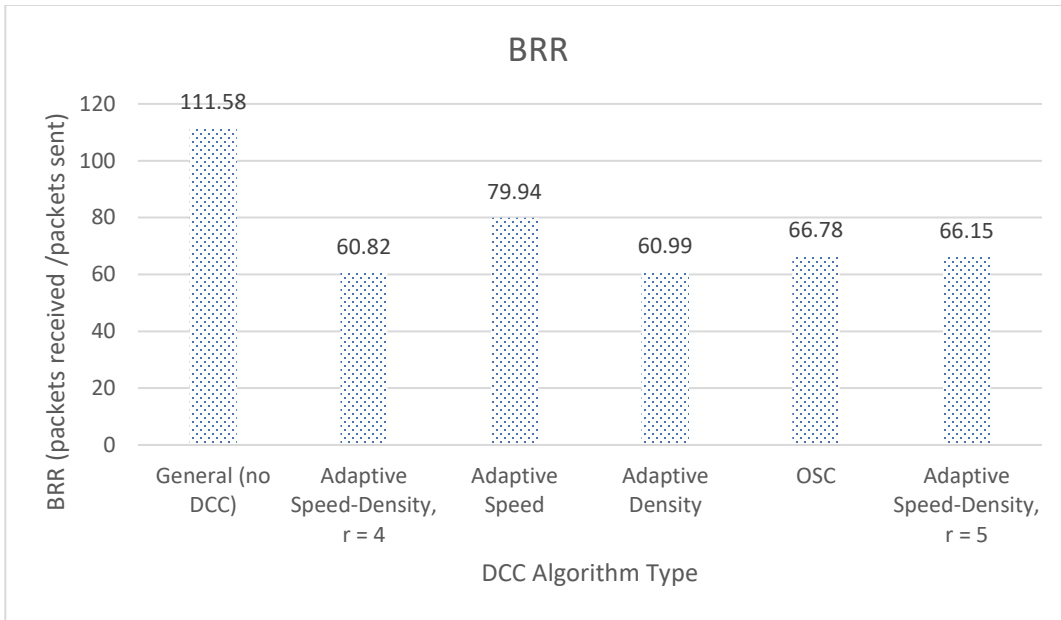

Figure 4.12 BRR in the 12-lane fast highway simulation

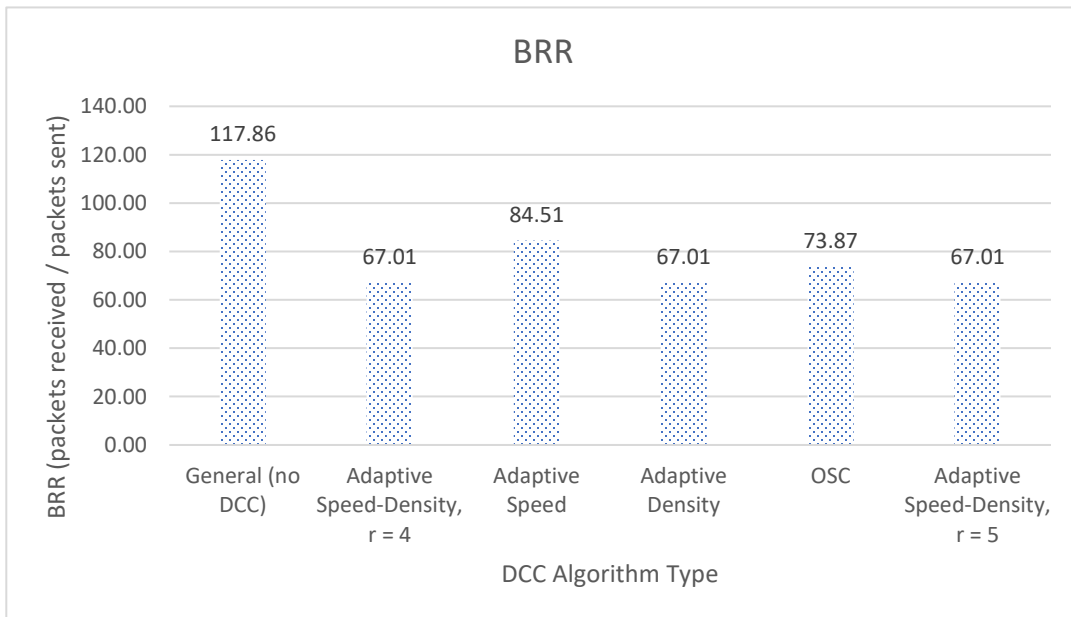

Figure 4.13 BRR in the 12-lane slow highway simulation

4.2.5 Beacon Error Rate

The BER is the ratio of lost packets to received packets. In figure 4.14, we see that there is not a significant difference between the general approach of no DCC, and the DCC approaches. However, when considering figures 4.15 and 4.16, we can see that an increased load in the network exposes the packet loss rate in the general approach and speed-based approach. With a high BER, we cannot reliably say that important BSMSs will be received at the appropriate times (such as when a vehicle collision is imminent) and therefore translates to less reliable performance in safety applications. In figure 4.16 we can see that the proposed algorithm performs very similarly to the density-based approach, having the lowest BER among all DCC algorithms.

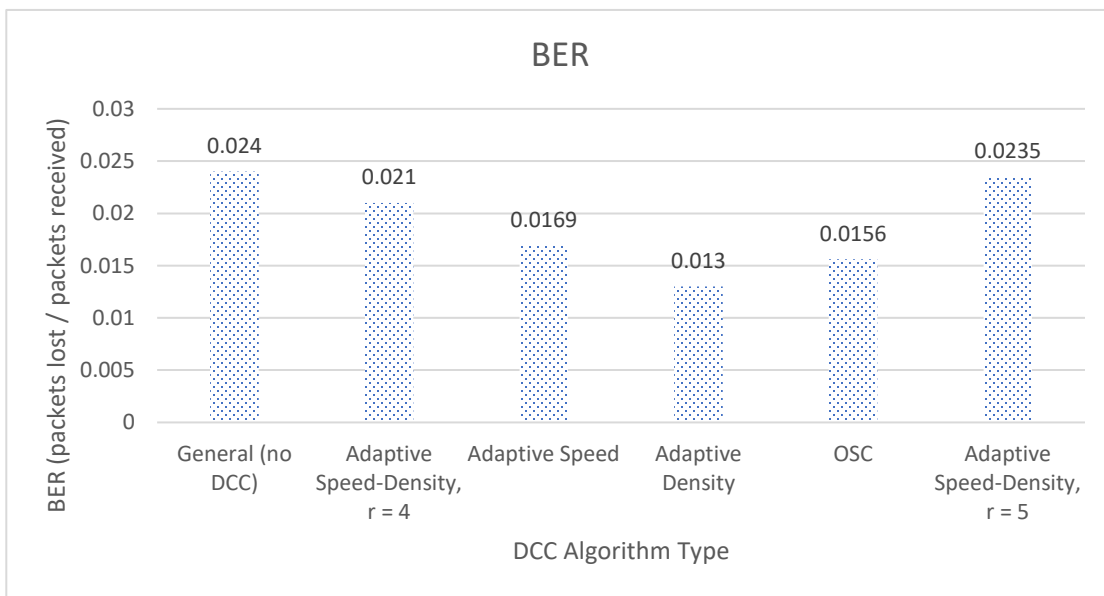

Figure 4.14 BER in the 6-lane highway simulation

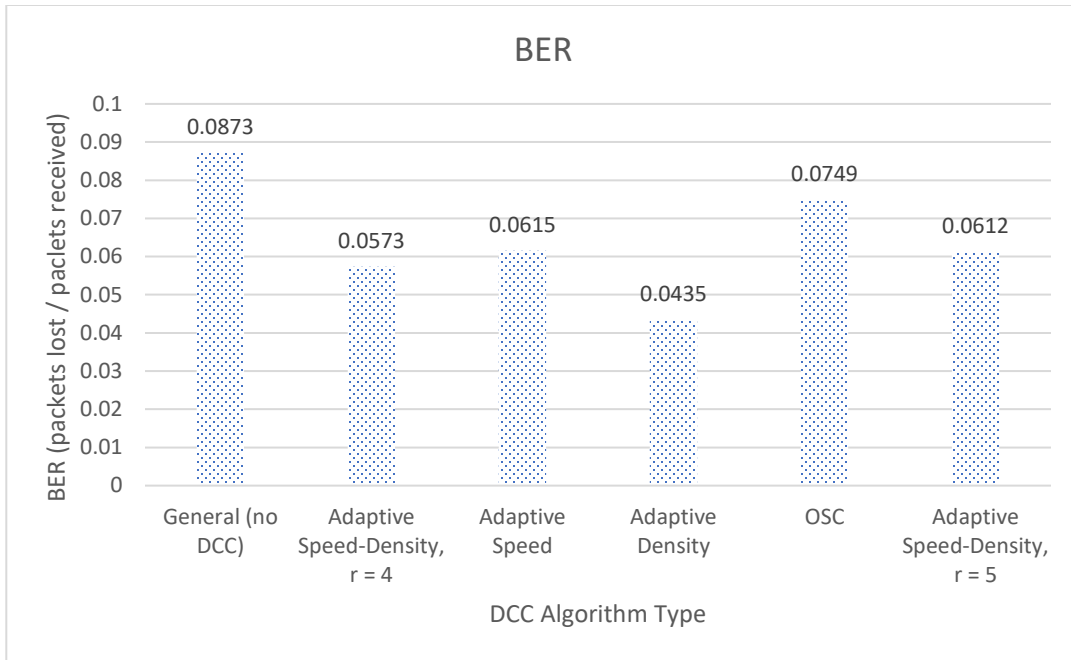

Figure 4.15 BER in the 12-lane fast highway simulation

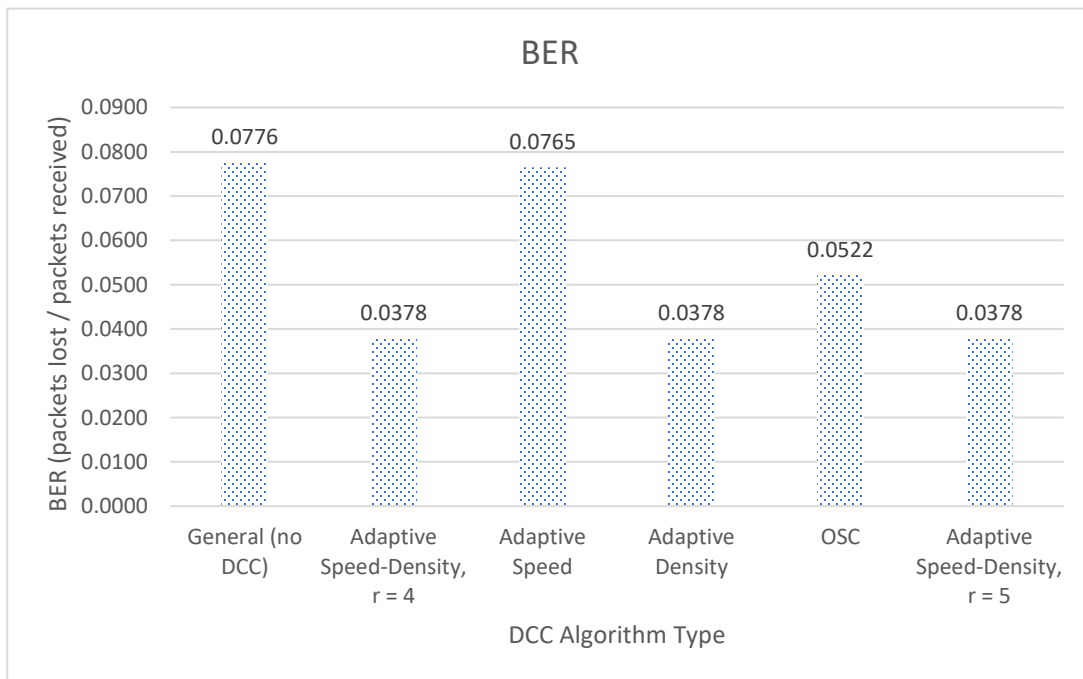

Figure 4.16 BER in the 12-lane slow highway simulation

4.2.6 Channel Busy Time

CBT is another way to approximate the amount of congestion in a network. Before transmitting a message, the transmitting vehicle must first listen and check if the channel is clear. If there aren't currently any messages propagating through the network (that the transmitter is capable of hearing) then it proceeds with its broadcast. However, if nearby broadcasts are heard, the transmitter must wait an amount of time before testing the channel again, and assure the channel is clear for transmitting. The total amount of time spent waiting in this manner is the CBT, which can be different for each vehicle. To measure this value, we take the average total amount of CBT of each vehicle in the simulation. A high average translates to more congestion in the network, and vice versa. In figures 4.17, 4.18, and 4.19 we can see that the general approach of using no DCC results in much higher CBT than when using DCC. As the network load increases, we can see this effect increase. All DCC algorithms perform similarly in this area, with the speed-based algorithm having a slightly higher CBT than the rest. The error bars representing the 95% confidence intervals show us that the variability between individual data is similar among all algorithms, except in the 12-lanes-slow simulation, where we can see a smaller interval for the general approach compared to the rest.

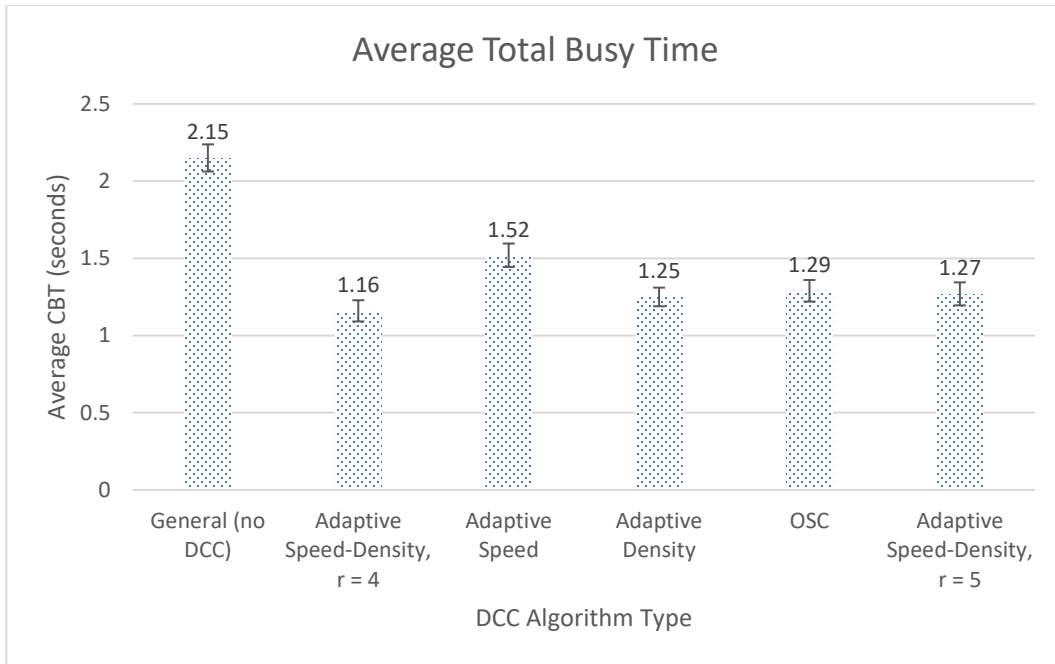

Figure 4.17 CBT in the 6-lane highway simulation⁷

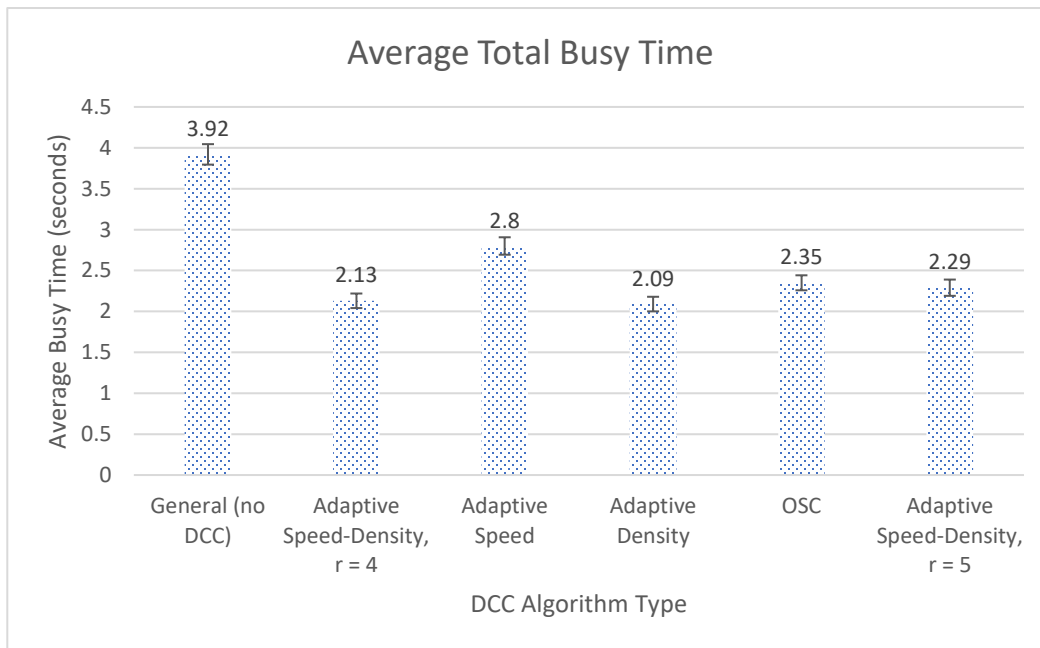

Figure 4.18 CBT in the 12-lane fast highway simulation⁸

⁷ 95% confidence values from left to right: 0.09, 0.07, 0.08, 0.06, 0.07, 0.07

⁸ 95% confidence values from left to right: 0.13, 0.09, 0.11, 0.09, 0.09, 0.10

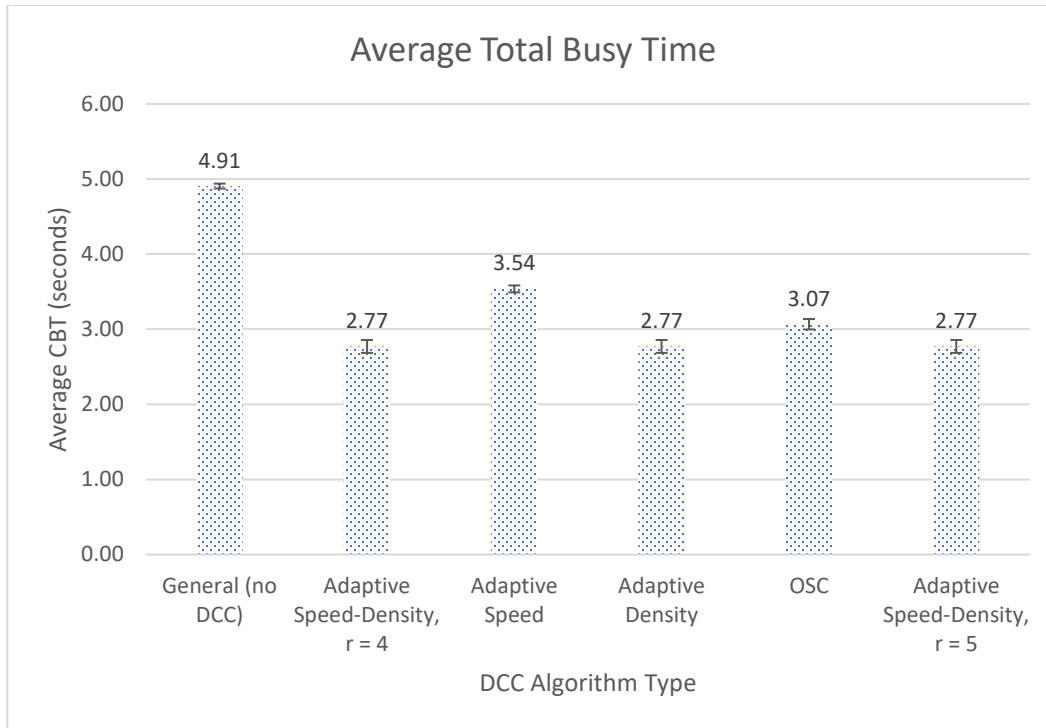

Figure 4.19 CBT in the 12-lane slow highway simulation⁹

4.2.7 Inter-Packet Delay

IPD is the amount of time in between received packets. A high delay between packets received means a high delay in the update of awareness for the receiving vehicle, which could potentially have a negative effect on safety application performance. However, to measure this in a more meaningful way, we have distinguished between packets received from various distance intervals. We separate the distance by 20-meter intervals and measure the average amount of time in between each packet received *from that distance interval*. As the DCC approaches limit the transmission power in various ways, we can see the performance in IPD change as the distance interval increases.

In our results, not all algorithms received packets from far distances. There is usually a maximum transmission range, which explains why some data points stop sooner for certain DCC

⁹ 95% confidence values from left to right: 0.03, 0.09, 0.05, 0.09, 0.07, 0.09

algorithms. Observing figures 4.20, 4.21 and 4.22, we see that IPD is generally low for distances less than 140m. After that we see a sharp increase in the OSC algorithm, and a gradual increase in the proposed algorithm, the density-based algorithm, and the speed-based algorithm. This is due to the OSC algorithm alternating between high and low power transitions, and the other algorithms gradually increasing/decreasing transmission power. Again, the general approach seems to have the lowest impact on IPD at further distances, but this is due to the consistent high transmission power and the fact that more packets are received from further distances. At closer distances there is a very slight, but non-significant improvement in IPD for DCC algorithms compared to the general approach of no DCC. In figure 4.22 we see a sharp increase for the proposed algorithm from the 160-180m range, as this is the transmission range limit for that algorithm. Fewer packets are received from this distance, and at a higher loss rate, making the IPD between packets at this range high. The error bars on the graphs, representing the 95% confidence intervals, show that the OSC algorithm has a high amount of variability in values compared to other algorithms, which remain slightly more consistent. The OSC algorithm behaves this way because it is always alternating throughout the duration of the simulation, making its individual vehicle results very volatile. In the proposed algorithm, the confidence interval is much larger in the values at the end of the transmission range. This is due to the very edge of the transmission range being less reliable for correctly receiving packets without error.

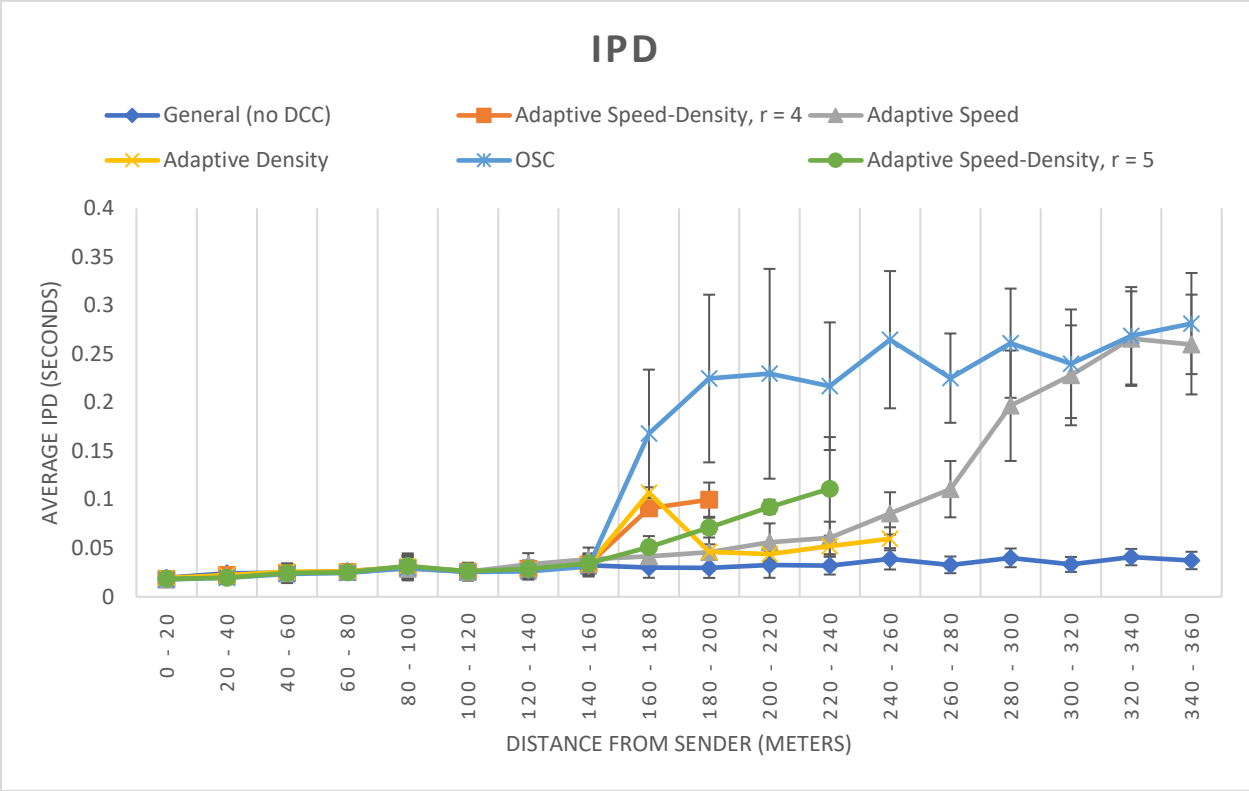

Figure 4.20 IPD in the 6-lane highway simulation

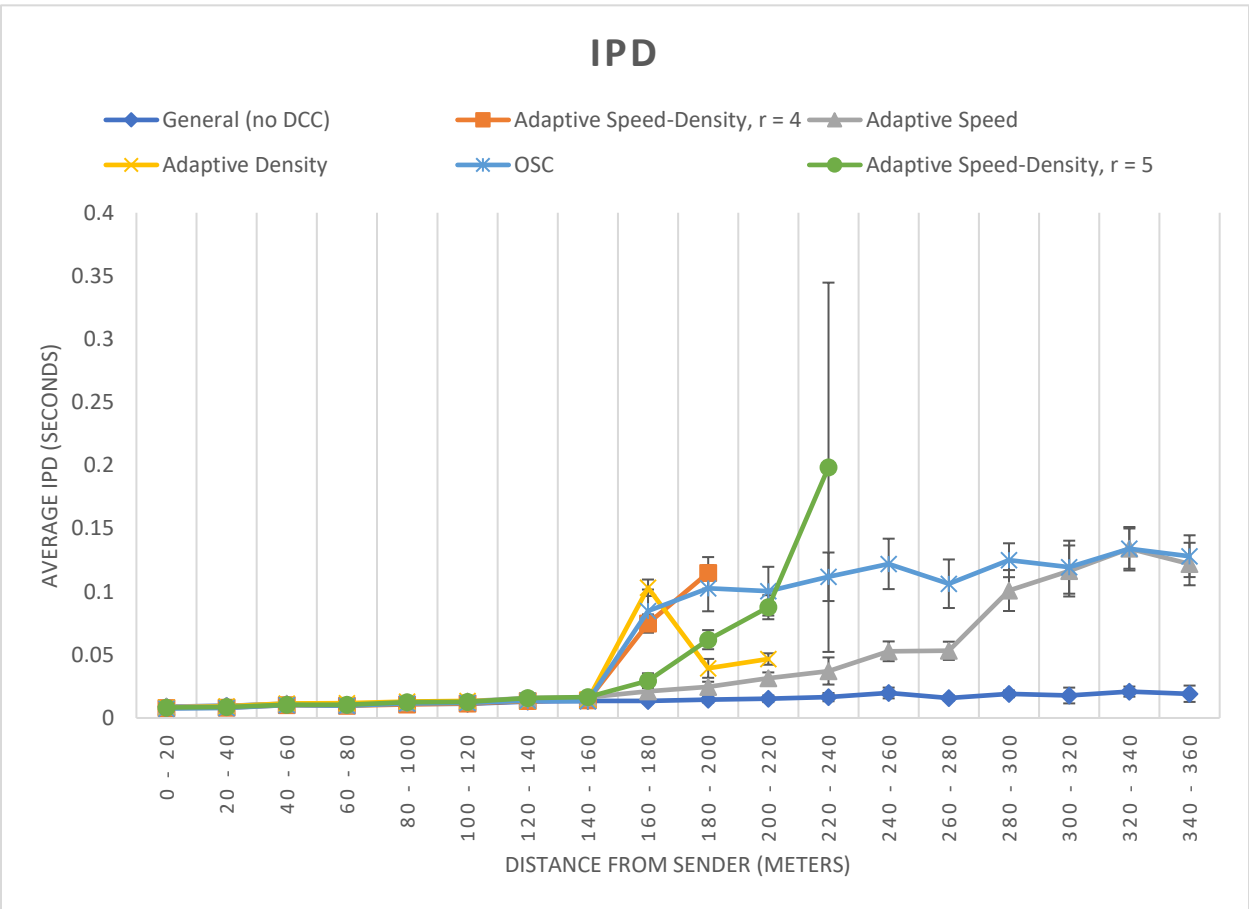

Figure 4.21 IPD in the 12-lane fast highway simulation

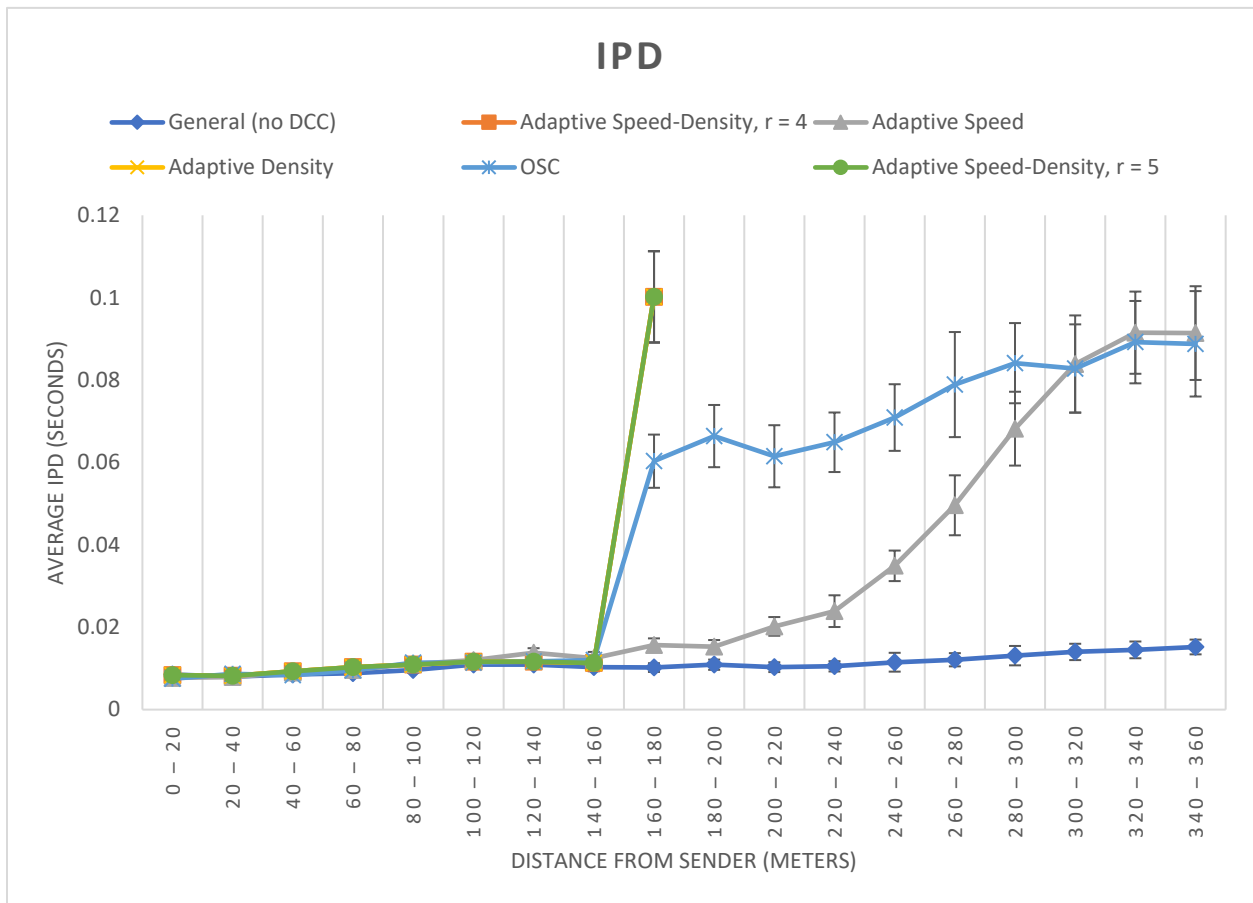

Figure 4.22 IPD in the 12-lane slow highway simulation

4.2.8 Relevance

Measuring the Relevance of packets as a performance metric of DCC algorithms by means of measuring the proportions of packets received from predetermined distance intervals is a new idea introduced in this thesis. The reason this is important to observe is because, to the average person, many of the previous performance results might make it look like using no DCC is better for safety applications than employing a DCC algorithm. This is because using no DCC

resulted in a higher BRR and a lower IPD. However, when observing relevance, we can see why these do not necessarily translate to good safety application performance.

In a real-life driving scenario, it is generally agreeable that paying attention to the neighboring vehicles closer to you is more important than paying attention to vehicles which are distant. While distant vehicles might have an impact on safety in certain situations (ex. icy driving conditions, where vehicles are not able to stop as quickly), hat traffic incidents are more likely to occur due to the actions of a nearby motorist, than a far one. This can be due to a variety of factors, such as human reaction time or blind spots. For this reason, we rate the relevance of the packets received in the network by how close the sender is to the receiver. The closer the sender, the more relevant the packet received, and vice versa.

To measure relevance, we again split the distances of messages received from sending vehicles into 20-meter intervals. Then we count the number of total packets received from each distance interval and divide it by the total number of received packets in the network. This gives us a percentage of packets received from each distance interval. Observing figures 4.23, 4.24, and 4.25 we can see that the proposed algorithm has the best performance in terms of relevance, having the highest proportion of high relevance packets. When the network load increases, we see that the density-based approach has very similar performance as the proposed algorithm, but in all cases, the general approach of no DCC has the lowest number of relevant messages, due to more messages being received from further away.

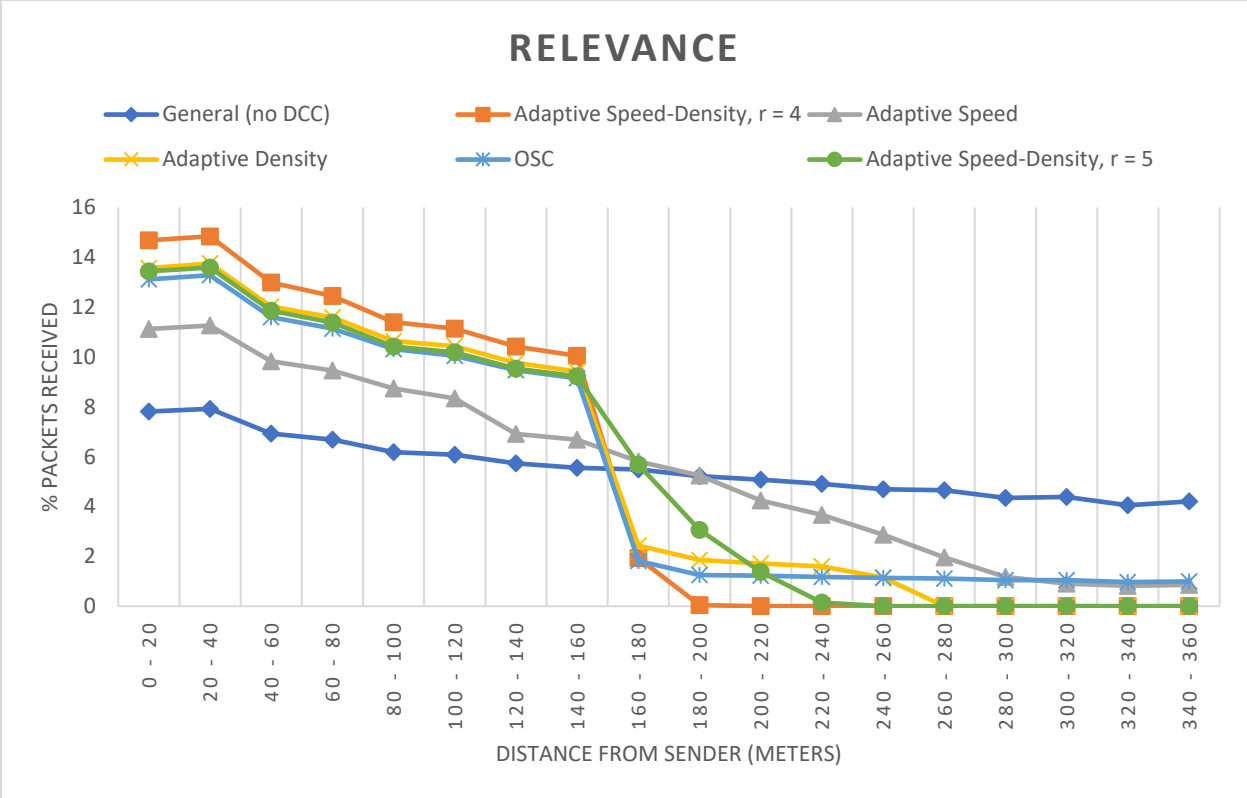

Figure 4.23 Relevance of packets in the 6-lane highway simulation

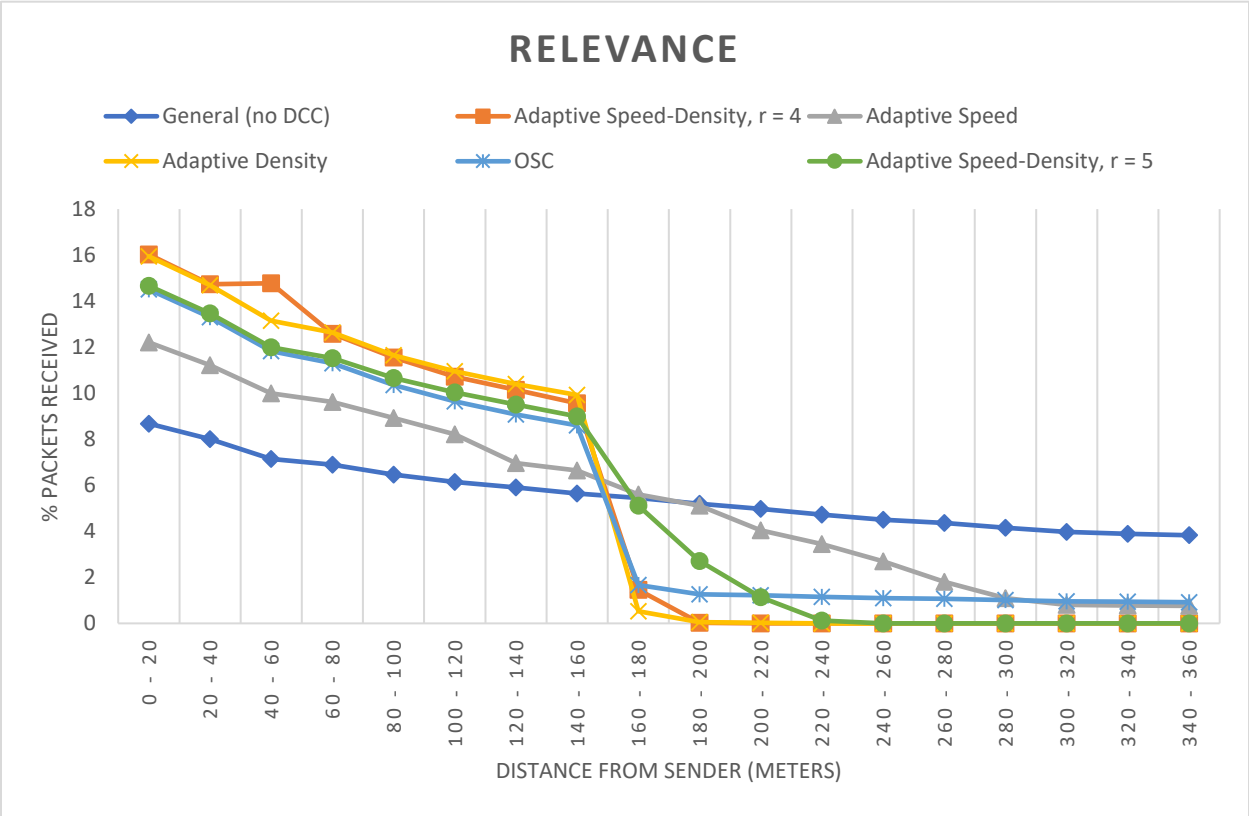

Figure 4.24 Relevance of packets in the 12-lane fast highway simulation

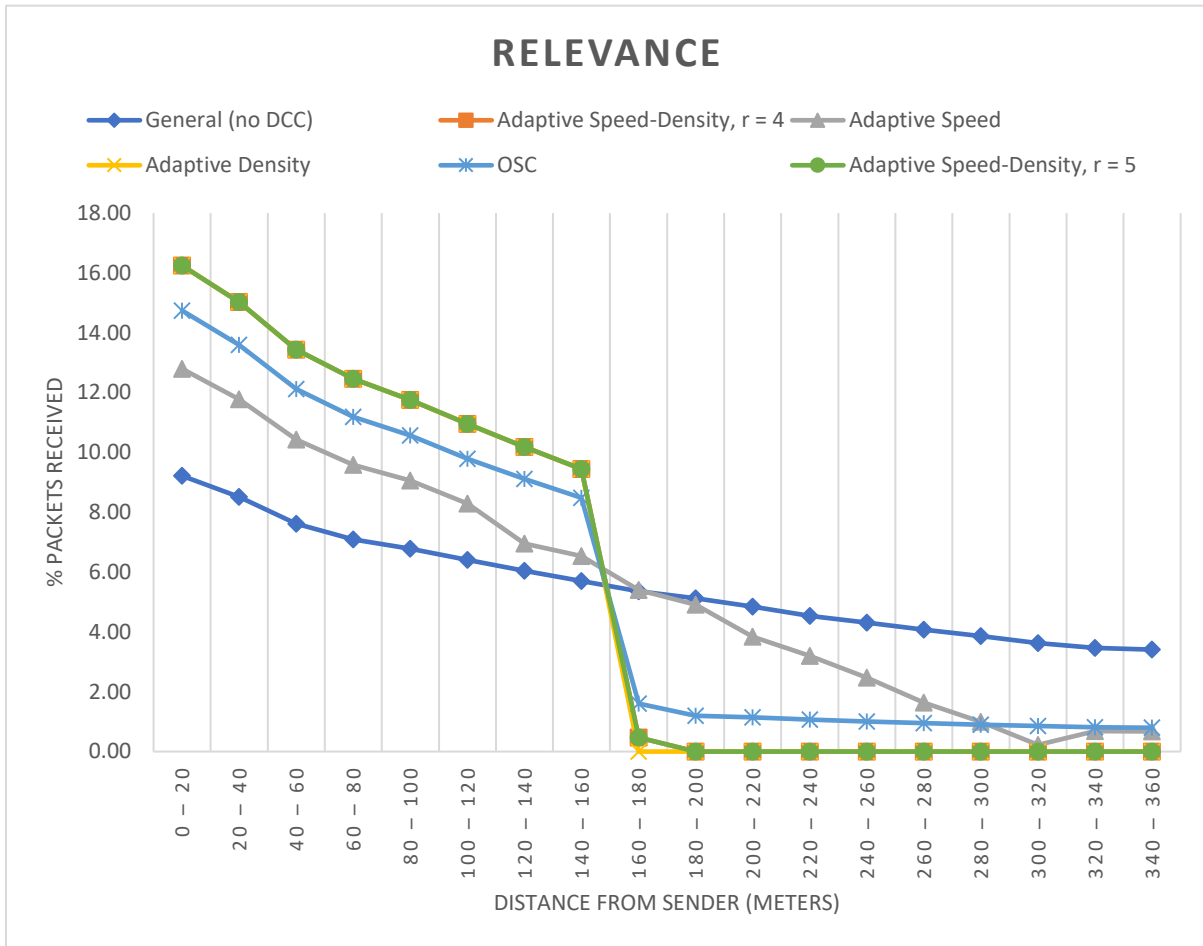

Figure 4.25 Relevance of packets in the 12-lane slow highway simulation

Chapter 5 Conclusions and Future Work

5.1 Conclusions

In this thesis we have proposed and analyzed a new method of adapting transmission power based on a vehicle-speed approximation of density. This approach directly extended the works of (Joseph, Liu, & Jaekel, 2018) and (Akinlade, Saini, Liu, & Jaekel, 2019) and proposed a new speed-based approach for calculating transmit power of BSM packets. The results show an improvement of congestion in a VANET based on a speed-approximation of density. It seems that the density (the closeness of vehicles) is an important factor contributing to congestion, as density-based power adjustment seemed to perform well in many scenarios. It also makes sense that a denser network would experience more overlap and collision than a sparse network. Solely basing the congestion control on speed worked moderately well but seems to be slightly outperformed in most areas by density-based approaches. We also found that the speed-density algorithm is effective at approximating the density of the network as it performed nearly the same as the density-only algorithm, demonstrating that the speed of the vehicles is directly related to the density of the network. We also found that adding relevance as a performance criterion helped show that reducing messages from distant vehicles can actually help the performance of safety applications by increasing the proportion of packets sent from nearby vehicles.

5.2 Future Work

There are many factors not considered in the simulations (such as non BSM messages propagating through the network) and more complex traffic scenarios as well as more complicated driving patterns (the introduction of 'platoons' or groups of vehicles traveling together, for

example). It would also be interesting to see how rate control would affect the algorithm and how the performance would compare to other rate control methods. The OSC approach could be incorporated into the proposed approach in order to improve the awareness of the distant network (have periodic high-power transmissions). The speed-approximation of the proposed algorithm's calculation could also be improved to be more adaptable (perhaps reactive to the receipt of messages) to more realistically approximate the density of the network rather than the current static approximation (which may or may not be accurate).

References

- Akinlade, O., Saini, I., Liu, X., & Jaekel, A. (2019). Traffic Density Based Distributed Congestion Control Strategy for Vehicular Communication. *2019 15th International Conference on Distributed Computing in Sensor Systems (DCOSS)*, 195–197. <https://doi.org/10.1109/DCOSS.2019.00053>
- Al-Sultan, S., Al-Doori, M. M., Al-Bayatti, A. H., & Zedan, H. (2014). A comprehensive survey on vehicular Ad Hoc network. *Journal of Network and Computer Applications*, 37, 380–392. <https://doi.org/10.1016/j.inca.2013.02.036>
- Andrews, J., Shakkottai, S., Heath, R., Jindal, N., Haenggi, M., Berry, R., ... Yener, A. (2008). Rethinking information theory for mobile ad hoc networks. *IEEE Communications Magazine*, 46(12), 94–101. <https://doi.org/10.1109/MCOM.2008.4689214>
- Bansal, G., Kenney, J. B., & Rohrs, C. E. (2013). LIMERIC: A Linear Adaptive Message Rate Algorithm for DSRC Congestion Control. *IEEE Transactions on Vehicular Technology*, 62(9), 4182–4197. <https://doi.org/10.1109/TVT.2013.2275014>
- Bansal, Gaurav, Lu, H., Kenney, J. B., & Poellabauer, C. (2013). EMBARC: Error Model Based Adaptive Rate Control for Vehicle-to-vehicle Communications. *Proceeding of the Tenth ACM International Workshop on Vehicular Inter-Networking, Systems, and Applications*, 41–50. <https://doi.org/10.1145/2482967.2482972>
- Bhattacharai, S., Naik, G., & Park, J.-M. J. (2019). Uplink Resource Allocation in IEEE 802.11ax. *ICC 2019 - 2019 IEEE International Conference on Communications (ICC)*, 1–6. <https://doi.org/10.1109/ICC.2019.8761594>
- Bouassida, M. S., & Shawky, M. (2008). On the congestion control within VANET. *2008 1st IFIP Wireless Days*, 1–5. <https://doi.org/10.1109/WD.2008.4812915>

- Canadian Motor Vehicle Traffic Collision Statistics: 2017—Transport Canada. (n.d.). Retrieved September 19, 2019, from <https://www.tc.gc.ca/eng/motorvehiclesafety/canadian-motor-vehicle-traffic-collision-statistics-2017.html>
- Cloudin, S., & Kumar, P. M. (2017). Challenges on Mobility Models Suitable to Vanet. *JSW*, 12, 91–100.
- Cronin, B. (n.d.). *Vehicle Based Data and Availability*. 13.
- Djahel, S., & Ghamri-Doudane, Y. (2012). A robust congestion control scheme for fast and reliable dissemination of safety messages in VANETs. *2012 IEEE Wireless Communications and Networking Conference (WCNC)*, 2264–2269. <https://doi.org/10.1109/WCNC.2012.6214170>
- FCC Allocates Spectrum 5.9 GHz Range for Intelligent Transportation Systems Uses. (n.d.). Retrieved November 6, 2019, from https://transition.fcc.gov/Bureaus/Engineering_Technology/News_Releases/1999/nret9006.html
- Government of Ontario, M. of T. (n.d.). Driver's Handbook. Retrieved December 16, 2019, from <http://www.mto.gov.on.ca/english/dandv/driver/handbook//section2.2.6.shtml>
- Hartenstein, H., & Laberteaux, L. P. (2008). A tutorial survey on vehicular ad hoc networks. *IEEE Communications Magazine*, 46(6), 164–171. <https://doi.org/10.1109/MCOM.2008.4539481>
- Hasrouny, H., Samhat, A. E., Bassil, C., & Laouiti, A. (2017). VANet security challenges and solutions: A survey. *Vehicular Communications*, 7, 7–20. <https://doi.org/10.1016/j.vehcom.2017.01.002>
- Idrissi, A., Laghrissi, A., Retal, S., & Rehioui, H. (2015). VANET congestion control approach using empathy. *2015 5th International Conference on Information Communication Technology and Accessibility (ICTA)*, 1–6. <https://doi.org/10.1109/ICTA.2015.7426938>
- Intelligent Transportation System (ITS). (n.d.). Retrieved November 7, 2019, from <https://www.citywindsor.ca/residents/transitwindsor/where-is-my-bus/Pages/ITS.aspx>
- Joseph, M., Liu, X., & Jaekel, A. (2018). An Adaptive Power Level Control Algorithm for DSRC Congestion Control. *Proceedings of the 8th ACM Symposium on Design and Analysis of*

Intelligent Vehicular Networks and Applications, 57–62.

<https://doi.org/10.1145/3272036.3272041>

Kabir, T., Nurain, N., & Kabir, M. H. (2015). Pro-AODV (Proactive AODV): Simple modifications to AODV for proactively minimizing congestion in VANETs. *2015 International Conference on Networking Systems and Security (NSysS)*, 1–6. <https://doi.org/10.1109/NSysS.2015.7043521>

Kenney, J. B. (2011). Dedicated Short-Range Communications (DSRC) Standards in the United States. *Proceedings of the IEEE*, 99(7), 1162–1182. <https://doi.org/10.1109/JPROC.2011.2132790>

Le, L., Baldessari, R., Salvador, P., Festag, A., & Zhang, W. (2011). Performance Evaluation of Beacon Congestion Control Algorithms for VANETs. *2011 IEEE Global Telecommunications Conference - GLOBECOM 2011*, 1–6. <https://doi.org/10.1109/GLOCOM.2011.6133897>

Lei, G., Liu, F., Wang, P., Wang, X., & Wang, N. (2014). Power Adjustment Based Congestion Control in Vehicular Ad-hoc Networks. *2014 4th International Conference on Artificial Intelligence with Applications in Engineering and Technology*, 280–285. <https://doi.org/10.1109/ICAJET.2014.53>

Mitra, S., & Mondal, A. (2014). Joint Congestion Control Strategy During V2V Communication Among Authentic Vehicles in VANET. *Wireless Personal Communications*, 79(1), 43–67. <https://doi.org/10.1007/s11277-014-1840-x>

Ogura, K., Katto, J., & Takai, M. (2013). BRAEVE: Stable and adaptive BSM rate control over IEEE802.11p vehicular networks. *2013 IEEE 10th Consumer Communications and Networking Conference (CCNC)*, 745–748. <https://doi.org/10.1109/CCNC.2013.6488540>

OMNeT++ Discrete Event Simulator. (n.d.). Retrieved December 22, 2019, from <https://omnetpp.org/>

Orozco, A., Michoud, R., & Ramírez, G. (2013). Routing Protocols simulation for Efficiency Applications in Vehicular Environments. *Sistemas y Telemática*, 11, 27. <https://doi.org/10.18046/syt.v11i27.1693>

Qureshi, K. N., & Abdullah, A. H. (2013). *A Survey on Intelligent Transportation Systems*. 15.

- Sill, S. (2012, December). Dedicated-short-range-communications-factsheet.pdf. Retrieved November 20, 2018, from Wwww.tampacvpilot.com website: <https://www.tampacvpilot.com/wp-content/uploads/2016/12/dedicated-short-range-communications-factsheet.pdf>
- Singh, J., & Singh, K. (2018). Congestion Control in Vehicular Ad Hoc Network: A Review. In D. K. Lobiyal, V. Mansotra, & U. Singh (Eds.), *Next-Generation Networks* (pp. 489–496). https://doi.org/10.1007/978-981-10-6005-2_49
- Smely, D., Rührup, S., Schmidt, R. K., Kenney, J., & Sjöberg, K. (2015). Decentralized Congestion Control Techniques for VANETs. In C. Campolo, A. Molinaro, & R. Scopigno (Eds.), *Vehicular ad hoc Networks: Standards, Solutions, and Research* (pp. 165–191). https://doi.org/10.1007/978-3-319-15497-8_6
- Smith, R. (2015). Directive 2010/41/EU of the European Parliament and of the Council of 7 July 2010. In R. Smith, *Core EU Legislation* (pp. 352–355). https://doi.org/10.1007/978-1-137-54482-7_33
- SUMO - Simulation of Urban Mobility. (n.d.). Retrieved December 22, 2019, from <https://sumo.dlr.de/index.html>
- Taherkhani, N., & Pierre, S. (2016). Centralized and Localized Data Congestion Control Strategy for Vehicular Ad Hoc Networks Using a Machine Learning Clustering Algorithm. *IEEE Transactions on Intelligent Transportation Systems*, 17(11), 3275–3285. <https://doi.org/10.1109/TITS.2016.2546555>
- Torrent-Moreno, M., Santi, P., & Hartenstein, H. (2006). Distributed Fair Transmit Power Adjustment for Vehicular Ad Hoc Networks. *2006 3rd Annual IEEE Communications Society on Sensor and Ad Hoc Communications and Networks*, 2, 479–488. <https://doi.org/10.1109/SAHCN.2006.288504>
- Veins. (n.d.). Retrieved December 22, 2019, from <https://veins.car2x.org/>
- Willis, J. T., Jaekel, A., & Saini, I. (2017). Decentralized congestion control algorithm for vehicular networks using oscillating transmission power. *2017 Wireless Telecommunications Symposium (WTS)*, 1–5. <https://doi.org/10.1109/WTS.2017.7943531>

Xu, Q., & Sengupta, R. (2004). Vehicle-to-vehicle safety messaging in DSRC. *Proc. of the 1st ACM Workshop on Vehicular Ad-Hoc Networks*. ACM Press.

Vita Auctoris

NAME: Caitlin Facchina

PLACE OF BIRTH: Windsor, Ontario

YEAR OF BIRTH: 1993

EDUCATION: Walkerville Collegiate Institute, Windsor, Ontario

Graduated: 2012

University of Windsor, Windsor, Ontario

2012 – 2016 BSc.

University of Windsor, Windsor, Ontario

2018 – 2020 Msc.