

Stephen F. Austin State University

SFA ScholarWorks

Faculty Publications

Physics and Astronomy

2017

A Summer Camp in Engineering Physics for Incoming Freshman to Improve Retention and Student Success

Hector A. Ochoa

Stephen F Austin State University, ochoah@sfasu.edu

Christopher J. Aul

Stephen F Austin State University, aulcj@sfasu.edu

Dan Bruton

Stephen F Austin State University, dbruton@sfasu.edu

Collin J. Timmons

Stephen F Austin State University, timmonscej@sfasu.edu

Follow this and additional works at: https://scholarworks.sfasu.edu/physicsandastronomy_facultypubs



Part of the [Educational Methods Commons](#), [Engineering Commons](#), [Higher Education Commons](#), and the [Physics Commons](#)

[Tell us](#) how this article helped you.

Repository Citation

Ochoa, Hector A.; Aul, Christopher J.; Bruton, Dan; and Timmons, Collin J., "A Summer Camp in Engineering Physics for Incoming Freshman to Improve Retention and Student Success" (2017). *Faculty Publications*. 8.

https://scholarworks.sfasu.edu/physicsandastronomy_facultypubs/8

This Article is brought to you for free and open access by the Physics and Astronomy at SFA ScholarWorks. It has been accepted for inclusion in Faculty Publications by an authorized administrator of SFA ScholarWorks. For more information, please contact cdsscholarworks@sfasu.edu.

A Summer Camp in Engineering Physics for Incoming Freshman to Improve Retention and Student Success

Dr. Hector A. Ochoa, Stephen F. Austin State University

Hector A. Ochoa received his Ph.D. in computer engineering from The University of Texas at El Paso in 2007. He received his M.S. in Physical Sciences from The University of Texas at El Paso in 2004. He joined The University of Texas at Tyler as a visiting professor at the department of electrical engineering on Fall of 2007. In fall of 2008, he started working as an assistant professor at the same university. On the Spring of 2016 he Joined Stephen F. Austin University, teaching at the program in Engineering Physics. His research interests include: Radar Systems, Wireless Communications and Antennas.

Dr. Christopher J. Aul, Stephen F. Austin State University

Mechanical Engineering professor at Stephen F. Austin State University serving the Engineering Physics degree within the Department of Physics, Engineering and Astronomy. Research interests include combustion chemistry, laser diagnostics, engineering education, and outreach programs in STEM.

Dr. Dan Bruton, Stephen F. Austin State University

Dr. Dan Bruton is a professor of Physics at Stephen F. Austin State University. He is an Associate Dean of the College of Sciences and Mathematics and recently developed a new Engineering Physics degree program for SFA Students. He received his Ph.D. in physics from Texas A&M University and has a bachelors and masters degree in physics from Stephen F. Austin State University. He teaches courses in engineering, physics, and astronomy and conducts research at the SFA Observatory. Several master's theses and over 60 publications in the Minor Planet Electronic Circulars have resulted from minor planet research at SFA to date. He teaches Foundations in Engineering, Electrical Engineering, Digital Systems, and Observational Astronomy at SFA. A complete list of research and scholarly activities can be found at www.danbruton.com.

Mr. Collin J Timmons, Stephen F. Austin State University

Mr. Collin Timmons is a visiting lecturer in the Department of Physics, Engineering, and Astronomy at Stephen F Austin State University. He teaches courses in physics and engineering. He received his bachelors and masters degree in physics from Stephen F Austin State University.

A Summer Camp in Engineering Physics for Incoming Freshman to Improve Retention and Student Success

Abstract

Summer camps have proven to be a valuable tool to attract and recruit students interested in pursuing a career in the STEM field. They have also been used to spark curiosity in areas such as mathematics, chemistry, and engineering. However, these camps do not help with issues that appear after the student has been admitted to the university. It is well known that many students suffer a shock when they transition from high-school to college. By realizing this situation, a one-week resident summer camp for incoming freshman has been created at Stephen F. Austin (SFA) State University. The goal of this camp is to help freshmen with their transition from high-school to college. During the summer camp, they review concepts related to Math and Science. They are introduced to the campus and resources available, and they meet other students who are also interested in pursuing a career in the STEM field. The students stay at the dormitories located in campus; they eat at the cafeteria, and they collaborate with the professors in classroom and laboratory settings. So far, data has shown that most of the students that started an STEM major, stayed on that major at least for the freshman year.

Summer Camps

There is a wide variety of summer camps. Some of them are designed to recruit and promote universities¹⁻³. The majority of these summer camps focus on promoting programs to minority groups in order to spark some interest⁴⁻⁶. Other camps are designed to prepare students for future courses that they will take during the freshman year⁷⁻⁸. It needs to be clear that there is nothing wrong with these programs. They are great ideas that had boosted the participation of minority groups on STEM areas, had reduced attrition, and had increased success rate of entering freshmen. However, most of these summer camps are not addressing one important factor that is affecting many students starting college education. High-school to college transition is a big problem for many college students⁹⁻¹⁰. Many of these students start on a new place, with new friends, new professors, and with a new set of rules. The research done by Fromme¹¹ with 2,245 students showed that the transition from high school to college represents a very important developmental milestone, and it has the potential of holding the personal growth of the students and changes their behavior. The study showed an increase on alcohol use, marijuana use, and sex with multiple partners during their first years. Another shock that occurs from the high school to college transition is the communication with high school best friends. The research done by Oswald¹² shows that most of these friendships deteriorate due to the lack of periodic communication. Another important change on students transitioning from high school to college is their diet, physical activity, and body weight. This was studied by Wengree¹³ and involved 186 entering freshman students. The research showed that almost a quarter of the students gained a significant amount of weight due to changes in their routine.

The results from the research studies presented on the previous paragraph show that it is very important to help students with the transition from high school to college. For that reason, Stephen F. Austin (SFA) State University has created the Summer Math and Science Highlights (SMASH) Camp in an effort to help students with the transition, and the academic requirements of college. In the following sections, this paper will outline the contents of the summer camp, and how it is trying to ease this shocking transition for entering freshmen.

The Summer Math and Science Highlights (SMASH) Camp

The SMASH was first offered to incoming freshman during the summer of 2011. It is designed to make the transition from high school to college more enjoyable and less stressful. The SMASH Camp reiterates math and science concepts, introduces students to SFA campus and its resources, and allows students to experience camaraderie with others who are also interested in pursuing a degree in the STEM field.

The opportunity is presented to the students during the freshmen orientations. During the presentation, the goals of the summer camp are explained to the students. The registration to the summer camp is completely voluntary. During the camp, the students will be assigned to a dormitory with other students taking the camp. This means that for a whole week, these students will be interacting with students pursuing a degree in one of the STEM fields. The students are given a schedule of activities for the entire week. These activities include: crash courses in Chemistry and Mathematics, breakfast, lunch, dinner, laboratory activities, library activities, and identifying resources. Furthermore, current STEM students are assigned as counselors. The purpose of the counselors is to help the students to adapt to the new life. They show them how to move around campus, how to organize their time, and how to become successful on college. All this is from the point of view of a current student, and not from a professor's point of view.

The goal of the intensive preparation in Chemistry and Mathematics is to get the students ready for these college courses. In the scenario in which a student was not able to perform at the level expected, he/she is advised to take some leveling courses (e.g. pre-calculus, trigonometry, algebra, etc.) to get it prepared for college-level courses. During the summer camp, the students also learn about the different resources available on campus.

The campers are divided in two groups depending on their interest during the welcoming session. Students interested in Physics and Engineering are encouraged to attend the special session prepared by the department of Physics, Engineering, and Astronomy. Details about the session are presented in the following section.

Engineering Physics Special Laboratory Sessions

The Engineering Physics laboratory session changes every year. The goal is to keep the content fresh, and interesting for the campers. "*Find a solution to a real-world problem*" is the theme

used while selecting the project for the summer camp. For the 2016 summer camp, the problem was decided to be: How do you deliver a payload from a high-altitude, and track it so it will not be lost? In order to simulate this problem the students were given to following tasks:

- Build a tracking system on a breadboard
- Design and build a delivery system
- Attach the proposed design to the bottom of a drone, and test it from different altitudes
- The contents (breadboard circuit) should survive the drop

The students were given a couple of lectures to get them ready for the project. The first session was on Mechanical Engineering, and the Physics of dropping an object. The objective was to help the students understand what happens when an object falls, and how to reduce the damage made by the impact. The second session was on Electrical Engineering, and the Physics on a circuit. This was intended to help the students understand more about the tracking circuit, and how we are able to locate an object using an antenna. Due to the complexity of designing a tracking circuit, each group was given the circuit diagram of Figure 1. Then they were asked to build the circuit on the breadboard using standard laboratory components. It needs to be noted that each team built their own inductor (coil) using magnet wire. As a result, each tracking circuit was working at a different frequency.

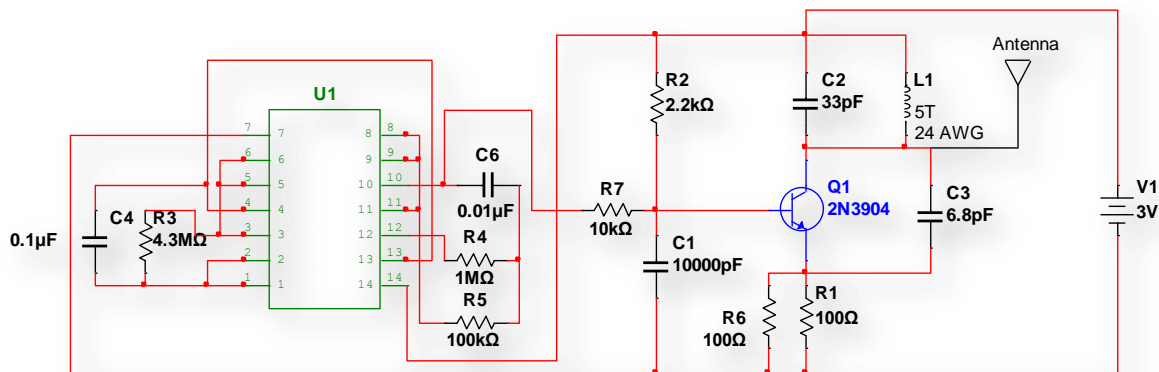

Figure 1. Tracking system circuit diagram.

In order to build the frame, the students had materials such as foam, glue, wood stick, and rubber bands just to mention a few of them. They were trained on how to use SOLIDWORKS to design 3D objects, and how to operate the 3D printers. As it was expected, by the end the week, the students came up with different designs, each of them with their own level of ingenuity. Once their proposed designs were completed, they were attached to the drone, and dropped from an altitude of nearly 400 ft. It can be assured that the electrical engineering faculty was very disappointed of **not seeing** resistor, capacitors, and coils flying all over the place. In other words, the students successfully designed an enclosure that will survive the drop, and keep the tracking circuit working properly. Some images of the students' proposed designs are shown in Figure 2.

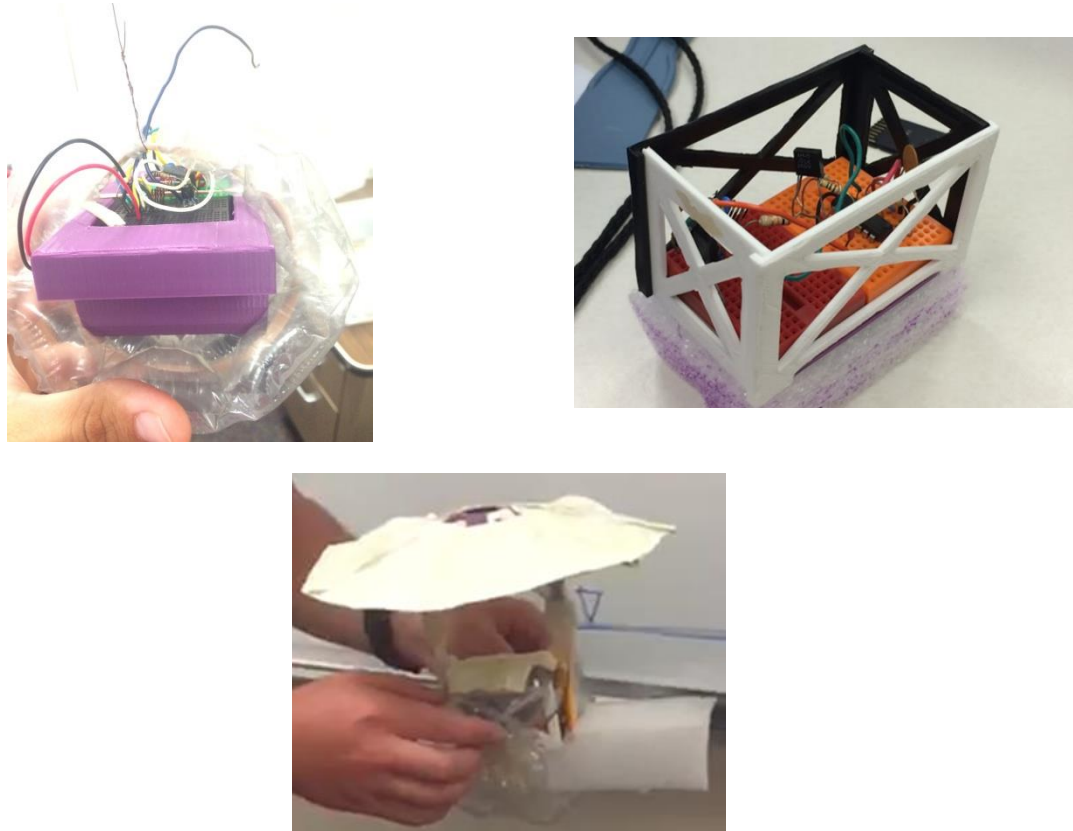

Figure 2. Students' proposed designs.

Advising

Every faculty member understands the value of advising. It has the potential of determining how a student will perform in a program. For that reason, the last day of the summer camp the students are called once more for advising. During this session, the faculty advisor discusses the student's performance during the summer camp. Then the advisor looks back into the courses for which the student is already registered, and makes recommendations based on the observations. The recommendations could be to move forward with the current schedule, or change it for something more appropriate for the student's level. For example, if a student under-performed on the math course during the summer camp, he/she will be recommended to take a few of the leveling courses offered (College Algebra, Trigonometry, Pre-Calculus, etc.).

Retention and Performance Results

The retention data for all the students who took the summer camp, and stayed in one of the STEM Majors is presented in Table 1. It needs to be noted that if a student switched from one

STEM major to another, he/she will still be counted as a retained student. The data regarding the retention for the Physics and Engineering Physics students is presented in Table 2.

Table 1. Number of campers that finished the freshmen year in one of the STEM Majors offered at the University.

Year	No. of students that took the summer camp	No. of student in a STEM Major
2011	17	7 (41%)
2012	24	15 (63%)
2013	27	17 (63%)
2014	16	13 (81%)
2015	24	23 (96%)
2016	37	35* (95%)

*At the moment this document was written, the students were taking courses of their second semester of the freshman year.

The following table shows the number of students admitted to the department, and finished their freshman year in the program.

Table 2. Number of campers registered in the Physics and Engineering Physics program and finished the freshmen year.

Year	No. of students admitted to the program that took the summer camp	No. of students that finished the freshmen year in the program
2012	2	2
2013	1	1
2014	3	3
2015	5	4
2016	9	8*

*At the moment this document was written, the students were taking courses of their second semester of the freshman year.

The data from Tables 1 and 2 show that a large percentage of the students who took the summer camp stayed as an STEM major after their freshman year. For example, in 2013 only an 81% of the students stayed in one of the STEM majors, but in 2015 a 96% of the students stayed in one of the STEM majors. It is believed that this increase is due to improvements, and changes that have been made to the camp during the years.

In terms of academic performance, Table 3 shows the average GPA for the cohort of students that took the summer camp. Notice how the average GPA has been increasing every year except for the cohort that took the camp during the summer of 2016. Furthermore, Figure 3 shows that a large percentage of the students that took the summer camp had a GPA between 2.5 and 3.5 by the end of their freshman year. Finally, Table 4 shows the number of campers in good standing (GPA>2.0) after their freshman year.

Table 3. Average freshman GPA for students that took the summer camp.

Year	No. of campers	Campers average GPA by the end of the freshman year
2011	17	2.63
2012	24	2.50
2013	27	2.58
2014	16	2.72
2015	23	2.99
2016	39	2.54*

*At the moment this document was written, the students were taking courses of their second semester of the freshman year.

Table 4. Number of campers in good standing after their freshman year.

Student Standing	2011	2012	2013	2014	2015	2016*
Good Standing (GPA > 2.0)	14	20	21	14	21	27
Probation	3	4	6	2	2	11

*At the moment this document was written, the students were taking courses of their second semester of the freshman year.

GPA Distribution for Campers

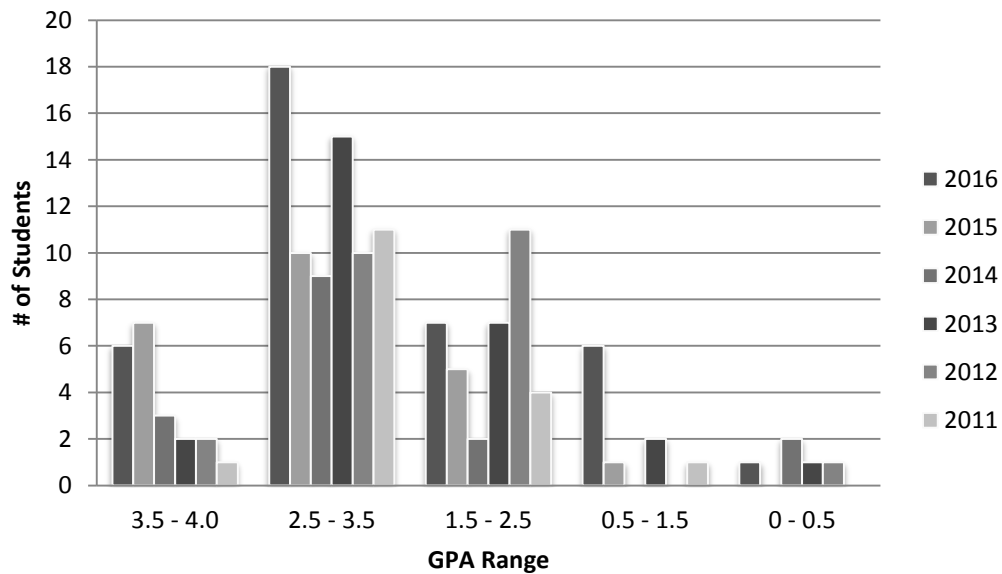

Figure 3. Freshman GPA distribution for the students that took the summer camp.

Conclusion and Future Work

On this paper, the Summer Math and Science Highlights (SMASH) camp from Stephen F. Austin (SFA) State University was presented. This summer camp like any other traditional camp is intended to improve the academics of students entering the university. However, this camp also aims to reduce the impact from the high-school to college transition. This is done by introducing the students to other freshmen students who are pursuing an STEM major, students who are already in a STEM program, and by staying at the dormitories located on campus. The collected data show that most of the students finished the freshman year in good standing, and they continued to the sophomore year. Data also shows that the average GPA for students that took the summer camp was very close to a GPA of 3.00. Furthermore, most of the students who took the camp attained a GPA between 2.5 and 3.5, placing them in good standing at the university. In terms of academic performance, it can be concluded that most of the campers are passing their courses, and moving forward in their careers.

Currently, the future of the summer camp is being discussed by the faculty involved in the project. The idea is to offer a revamped version of the camp during the summer of 2017. One of the ideas been proposed is to reduce time partition. With the current scheme, the students spend around 1-2 hours for three days working on their projects. The faculty believe that this affects their performance by breaking their attention into smaller time slots. It will be beneficial for the students to be working for longer periods of time on their projects, allowing them to focus, and generate better ideas and prototypes. Another idea that will be proposed is the creation of a control group. With the current scheme, every student who takes the camp is tracked for retention purposes and performance. However, without a benchmark it is hard to affirm that the students are performing better due to the summer camp. Finally, it will be proposed to give the campers two surveys. The first to be administered at the middle of the freshman year, and the second by the end of the freshman year. The surveys will ask the students if they feel the summer camp was beneficial to them in terms of academic performance, and transitioning from high school to college.

References

1. M. Yilmaz, J. Ren, S. Custer, and J. Coleman, "Hands-On Summer Camp to Attract K–12 Students to Engineering Fields," *IEEE Transactions on Education*, vol. 53, no. 1, pp. 144-151, 2010.
2. J. O. Attia, "Increasing electrical and computer engineering enrollment: A multi-faceted approach," 37th Annual Frontiers In Education Conference - Global Engineering:

Knowledge Without Borders, Opportunities Without Passports, Milwaukee, WI, 2007, pp. S4A-9-S4A-12.

3. L. Anderson, and K. Gilbride, "Pre-University Outreach: Encouraging Students to Consider Engineering Careers," *Global Journal of Engineering Education*, vol. 7, no. 1. c. 2003 UICEE.
4. C. Demetry and D. W. Nicoletti, "Camp REACH: An Engineering Summer Camp for Middle School Girls," *Proceedings Frontiers in Education 27th Annual Conference*, vol.1, pp. 511 1997.
5. J. Hannan, D. E. Calkins, R. W. Crain, K. L. Gentilli, C. Grimes, and M. S. Revisan, "An engineering design summer camp for a diverse group of high school students," *Proceedings Frontiers in Education 1997 27th Annual Conference. Teaching and Learning in an Era of Change*, Pittsburgh, PA, 1997, pp. 939-943 vol.2.
6. M. C. Baker and T. Karp, "Work In Progress: WE CAN: Introducing High School Girls to Electrical Engineering," *36th Annual Conference Proceedings Frontiers in Education*, pp. 1-2, 2006
7. K. Christensen, D. Rundus, H. Fujinoki, and D. Davis, "A Crash Course for Preparing Students for a First Course in Computing: Did it Work?," *Journal of Engineering Education*, vol 91, Issue 4, pp 409-413, October 2002.
8. D. C. Williams, Y. Ma, L. Prejean, M. J. Ford, and G. Lai, "Acquisition of Physics Content Knowledge and Scientific Inquiry Skills in a Robotics Summer Camp," *Journal of Research on Technology in Education*, vol 40, no 2, 2007
9. M. W. Kirst, and A. Venezia, "From High School to College: Improving Opportunities for Success in Postsecondary Education," *Teachers College Record*, vol 107, no 8, 2005.
10. S. P. Choy, L. J. Horn, A.-M. Nuñez, and X. Chen, "Transition to College: What Helps At-Risk Students and Students Whose Parents Did Not Attend College," *New Directions for Institutional Research*, vol 2000, Issue 107, pp. 45-63, 2000.
11. K. Fromme, W. R. Corbin, and M. I. Kruse, "Behavioral Risks during the Transition from High School to College." *Developmental Psychology*, vol 44, no 5, pp 1497–1504, 2008.
12. D. L. Oswald, and E. M. Clark, "Best friends forever?: High school best friendships and the transition to college," *Personal Relationships*, Vol 10, Issue 2, pp 187-196, June 2003.
13. H. J. Wengreen, and C. Moncur, "Change in diet, physical activity, and body weight among young-adults during the transition from high school to college," *Nutrition Journal*, 8:32, 2009.