

University of Arkansas, Fayetteville
ScholarWorks@UARK

Technical Reports

Arkansas Water Resources Center

6-1-1969

Subsurface Irrigation Research in Arkansas

John P. Hoskyn
University of Arkansas, Fayetteville

Billy B. Bryan
University of Arkansas, Fayetteville

Follow this and additional works at: <https://scholarworks.uark.edu/awrctr>



Part of the [Fresh Water Studies Commons](#), and the [Water Resource Management Commons](#)

Citation

Hoskyn, John P. and Bryan, Billy B.. 1969. Subsurface Irrigation Research in Arkansas. Arkansas Water Resource Center, Fayetteville, AR. PUB003. 28
<https://scholarworks.uark.edu/awrctr/354>

This Technical Report is brought to you for free and open access by the Arkansas Water Resources Center at ScholarWorks@UARK. It has been accepted for inclusion in Technical Reports by an authorized administrator of ScholarWorks@UARK. For more information, please contact ccmiddle@uark.edu.

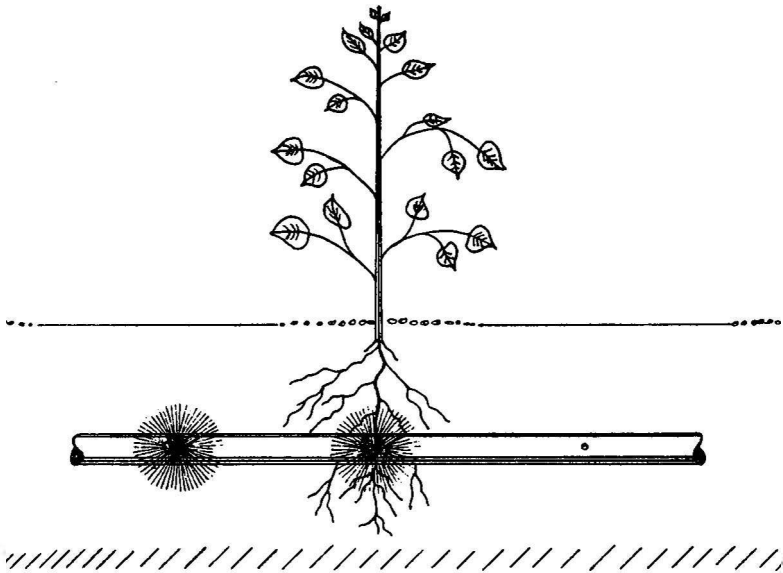

Subsurface Irrigation Research In Arkansas

WATER RESOURCES RESEARCH CENTER

Publication No. 3

in cooperation with

AGRICULTURAL EXPERIMENT STATION

Division of Agriculture

University of Arkansas, Fayetteville

OCT 14 1970

UNIVERSITY LIBRARY

UNIVERSITY OF ARKANSAS

FAYETTEVILLE, ARKANSAS 72701

GB
705
A8
A26
no. 3

CONTENTS

Introduction	3
Review of Literature	4
Pilot Study, 1963 and 1964	5
Objectives	6
Sequence of Investigation	6
Procedures and Discussion of Results	7
Water Distribution Study	7
Orifice Development	8
Greenhouse Study	13
Field Installation	15
System Automation	25
Summary and Conclusions	26
Literature Cited	28

ACKNOWLEDGMENT

The work upon which this publication is based was supported in part by funds provided by the Office of Water Resources Research of the Department of the Interior under Project A-002-ARK as authorized under Public Law 88-379.

Agricultural Experiment Station, University of Arkansas Division of Agriculture, Fayetteville. John W. White, vice president for agriculture; E. M. Cralley, director.
BPC2.5M669

MAY BE
CHECKED OUT

Subsurface Irrigation Research In Arkansas

By JOHN P. HOSKYN and BILLY B. BRYAN

Department of Agricultural Engineering

Increasing concern for our water resources and how better to utilize them has given rise to research efforts aimed at improving the efficiency of applying irrigation water. Among these research efforts are a number of investigations dealing with subsurface irrigation.

Subsurface irrigation has attracted attention because of the potential efficiency with which irrigation water can be applied using this method. Efficiencies of sprinkler irrigation systems range from 50 percent to 80 percent (5), with furrow irrigation efficiencies being somewhat less. It seems reasonable to assume that well-managed subirrigation systems could approach application efficiencies in excess of 90 percent. Such efficiencies are possible because of the significant reduction in evaporative and deep percolation losses and the virtual elimination of surface runoff losses.

Subirrigation, until recent years, has been possible only in a limited number of areas in which certain special conditions are found. The special topographic conditions that must be met before what Israelsen (8) calls natural subirrigation can take place are: a nearly level and smooth soil surface and a soil profile that includes a highly permeable stratum extending from the surface down to two feet or more, underlain by a relatively impermeable substratum. When these conditions are present, it is possible to create an artificial water table near enough to the surface to irrigate the root zone of various crops.

This research report deals with what Israelsen (8) calls artificial subirrigation: the introduction of irrigation water beneath the surface of the ground through a system of underground pipes in areas not meeting the necessary topographic conditions for natural subirrigation. The research reported was initiated in 1965 as a follow-up of a pilot project undertaken in 1963 by Bryan and Baker (2).

Review of Literature

A number of hydraulic criteria need to be evaluated before subirrigation will be feasible. Some of these criteria are: (1) the usable range of system operating pressure, (2) the optimum depth of placement of the distribution system, (3) a feasible orifice design, (4) the optimum number of orifices per unit area, and (5) water quality requirements.

Much research has been directed towards refining these criteria. Bryan and Baker (2) used operating pressures of 5 and 10 psi in a pilot study in 1963 and 1964. The 10 psi pressure caused excessive channeling, and some channeling was observed even at 5 psi. Whitney and Lo (14) indicated that operating pressures within the soil should fall within the range of $\frac{1}{2}$ to 10 psi in order to prevent excessive channeling and destruction of the soil structure. The feasible range of operating pressures varies with the specific application.

The depth of placement of the distribution laterals seems to be a function of the type of crop being irrigated, soil type, and tillage practices. Zetzsche (15) placed laterals at a depth of 16 inches under cotton on the High Plains area of Texas. Mitchell, et al. (10) used a 16-inch depth under corn. Other researchers placed laterals at depths of from 9 to 12 inches when irrigating field row crops or orchards (2, 6, 11). Busch and Kneebone (3) placed laterals at a depth of 6 inches underlain by 3 inches of pea gravel when subirrigating bermudagrass sod.

Most of the early subirrigation research was conducted with either drilled or punched orifices. Bryan and Baker (2) experienced a high incidence of internal stoppage as a direct result of drilling orifices. Whitney and Lo (14) indicated that orifices formed by punching tended to become smaller with time due to "rebound" of the plastic material. Punched holes of 1/16-inch diameter closed immediately to 1/32 inch, and then to 1/64 inch after three months. The punching method does have an advantage of being easily adaptable to forming of orifices as the pipe is being installed. This procedure was used by Zetzsche (15). Braud (1) investigated slit-type orifices in polyethylene plastic pipe. Uniformity of discharge seemed to be a limitation with this approach although uniformity may be improved with further development.

The optimum spacing of laterals and of orifices along the laterals has been investigated by several researchers. Zetzsche

(15) used 40 inches and 12 inches, respectively, for lateral and orifice spacing. Mitchell, et al. (10) used 36 and 12 inches for an initial study under corn and then conducted another study comparing lateral spacings of 40, 60, and 80 inches with the same orifice spacing; yields for the three lateral spacings were 115, 105, and 90 bushels per acre, respectively. These yield differences were significant. Hanson and Williams (6) used lateral spacings of 38 inches and orifice spacings of 12 inches.

Water quality has been a matter of great concern for all sub-irrigation investigators. Internal plugging of orifices because of low quality water has plagued a number of researchers (4, 6, 11, 14). Water of high quality seems to be necessary to insure the continued operation of any subirrigation system.

Pilot Study, 1963 and 1964

Since the pilot study of Bryan and Baker (2) served as a prelude to the project being reported, those results are summarized here. In the pilot study, six 100-foot lengths of $\frac{1}{4}$ -inch polyethylene plastic pipe, with orifices drilled on 2-foot centers, were installed at a depth of 12 inches. One-third of the orifices were $\frac{1}{64}$ inch in diameter and the remaining two-thirds were $\frac{1}{32}$ inch. These six laterals were connected to an irrigation well with a plastic-pipe supply line using the necessary valves and gauges. The system was operated at two pressure levels—5 and 10 psi. Cotton was grown above the system. The production results are shown in Table 1.

Two important observations regarding this system had an impact on the direction taken in subsequent research:

- (1) The method of forming orifices in the plastic pipe caused

Table 1. Cotton Yields in the Pilot Study, 1963

Replication	Not irrigated	Subirrigated
<i>Pounds seedcotton per acre</i>		
I	874	1,636
II	890	1,384
III	754	1,307
IV	1,124	2,458
V	1,105	1,703
VI	746	1,536
Mean	918	1,665
Increase from irrigation	749

stoppages to occur. Shavings and burrs resulted from the drilling operation. The burrs, which remained attached to the inside edge of the orifice, acted as "check valves" in that they tended to close over the orifice as water began to flow, causing either partial or complete stoppage. The shavings or loose particles that fell inside the pipe caused stoppage when carried into an orifice by the flow of water.

(2) The pressures used caused excessive "channeling" (water rising to surface). The 10 psi pressure caused the water to channel very quickly after the system was activated. Although the 5 psi pressure caused proportionately less channeling, the amount still was thought to be excessive.

It was concluded that: (1) a different method of forming orifices was needed, to eliminate the shavings and burrs resulting from the drilling operation; and (2) five pounds per square inch should be considered as the upper limit of pressure in subsequent research efforts.

OBJECTIVES

Objectives of the project were: (1) to determine and evaluate the hydraulic problems involved in distributing water subterraneously at low pressures in small-diameter, perforated plastic pipe for irrigating horticultural food crops and field crops; and (2) to develop criteria for design of subirrigation systems that approach the optimum in efficiency of water use.

Sequence of Investigation

The objectives were pursued in the following sequence:

(1) A laboratory study of water distribution patterns from a point source in a soil mass.

(2) An evaluation of various methods of producing orifices in the polyethylene plastic pipe to be used in the experimental subirrigation systems.

(3) Utilizing the information gained from 1 and 2 above, an evaluation of the small subirrigation system in terms of depth of pipe placement, spacing of laterals, and system operating pressure.

(4) Utilizing information from 3 above, design and installation of a field subirrigation system to further evaluate design and management variables.

(5) An investigation of currently-available control devices for irrigation systems with respect to their adaptability to the automatic control of a subirrigation system.

PROCEDURES AND DISCUSSION OF RESULTS

Water Distribution Study

Some of the factors affecting distribution patterns of water as it flows from an orifice into a surrounding soil mass are: (1) orifice size, (2) pressure applied to orifice, (3) soil type, (4) variation in soil permeability with depth (i.e. profile characteristics), and (5) variation in soil moisture content. One approach to such a study is to observe distribution patterns from a point source in a two-dimensional model using air-dried soil. This situation involves a relatively homogeneous, isotropic soil mass and reduces the variables with which one needs to be concerned to orifice size and system pressure.

Laboratory investigation of distribution patterns in this project was rather limited. The investigation involved the use of a two-dimensional model with transparent side panels through which patterns of water distribution could be observed. Pressures on the order of 2 psi were used, with an orifice size of 1/32 inch. The patterns observed, in general, approximated spherical distribution.

The observations with this model concurred with similar, more extensive research reported by Busch and Kneebone (3) and Pira, et al. (12).

Other observations of water distribution patterns were made during the operation of the field subirrigation system at the Vegetable Substation, Van Buren, discussed later in the section on "Field Installation." These observations were made on a grid of gravimetric soil moisture samples surrounding an orifice location. A soil moisture profile at an orifice (Figure 1) shows the effect of an existing soil moisture gradient preceding the start of irrigation. The movement of water was primarily into the soil above the level of the pipe as shown by the greater increase in soil moisture at the 3- and 9-inch levels as compared to the 15- and 21-inch

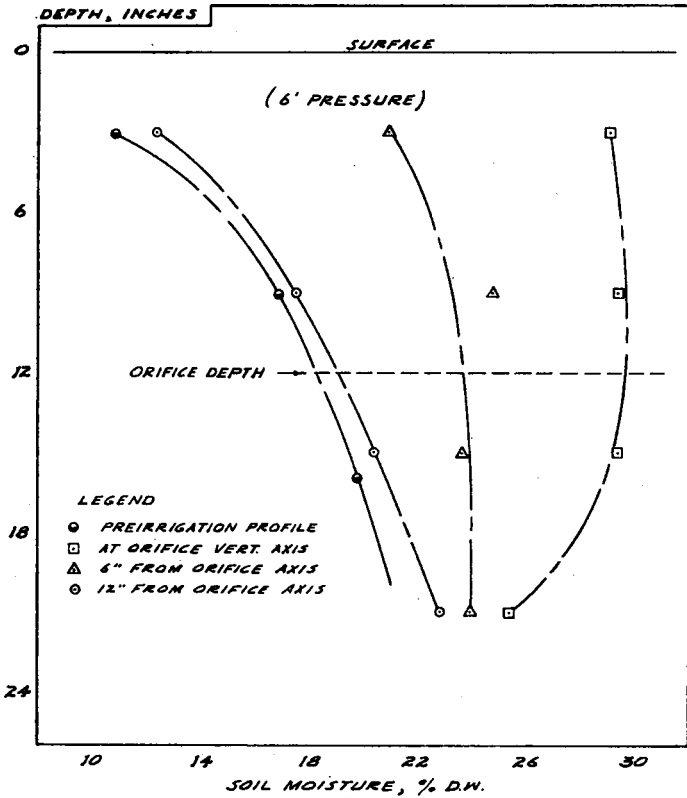

Figure 1. Moisture Profile at a Field Orifice

levels. This pattern of movement probably was influenced by decrease in the permeability of the soil with depth. A definite textural change was noted at a depth of about 14 inches during installation of the system.

The relatively greater vertical movement of water also may be attributable to an established piping channel that developed over a period of several irrigations. Such channels were in evidence at various locations in the installation.

Orifice Development

Orifice Selection

Of all the problems in successful development of a subirrigation system none is more important than the design of a dependable, inexpensive orifice through which the irrigation water can escape from the system lateral into the surrounding soil.

Almost without exception the drilled and punched orifices used in early subirrigation research had a high degree of internal stoppage as a result of the orifice-making process. The problems resulting from drilling orifices were mentioned previously. Orifices produced by punching experienced stoppages primarily because of the rebound effect of the polyethylene plastic used in the system.

The approach used in this project was to form the orifices with a heated, tapered needle. This method of forming eliminated the sources of internal plugging that resulted from the drilling operation (shavings and burrs) and from the punching operation (rebound).

Development of Orifice-Forming Device

A sketch of the device used in forming orifices by the heated-needle method is shown in Figure 2.

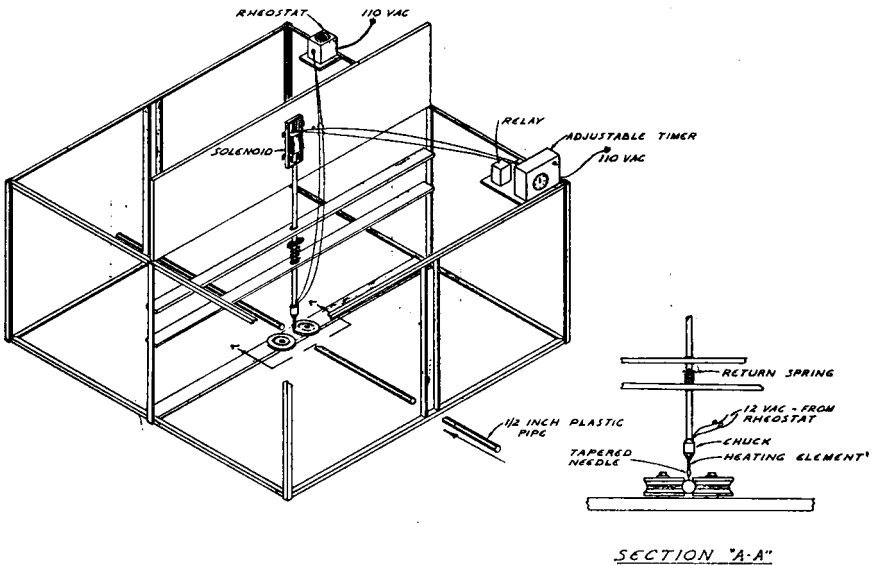

Figure 2. Hot-Needle Orifice-Forming Device

The salient features of this device are: (1) the needle is mounted on and heated by a 12V soldering iron, (2) the needle temperature is controlled by a rheostat which supplies power to the soldering iron heating element, (3) the soldering iron is mounted in a chuck which provides for vertical adjustment, (4)

pipe is fed through pipe guides and between rollers under the needle, (5) the needle is pushed through the pipe wall by a solenoid, and (6) needle contact time is controlled by an adjustable timer.

The needle used in the orifice-forming device was machined from a beryllium-copper alloy. Other alloys including the original soldering tip were investigated. However, of the reasonably available materials tested, the beryllium-copper alloy seemed to provide the best combination of mechanical strength, machinability, and conductivity.

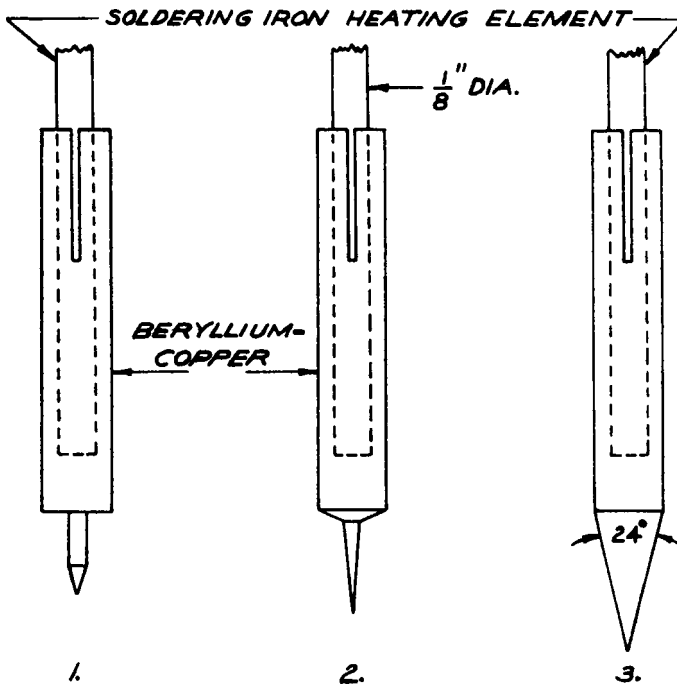

Figure 3. Three Needle Shapes Investigated

Three needle shapes were investigated (Figure 3). The shape which yielded the best performance in terms of mechanical strength, recovery time, and flexibility had a 12-degree taper as shown in design 3 in the figure. The other two shapes had three major limitations: (1) insufficient mechanical strength to withstand repetitive operation, (2) because of the small mass of metal in the slender needle point, excessive reduction of temperature during the punching operation with relatively slow recovery,

and (3) lack of flexibility relative to the size of orifices which could be formed.

The diameter of orifices produced by this method is a function of: (1) the depth of needle penetration through the pipe wall, (2) temperature of the needle, and (3) duration of needle contact with the pipe. No attempt was made to formally quantify these variables. A sketch of a typical orifice formed by the tapered, heated needle is shown in Figure 4.

An orifice diameter of 1/32 inch was the minimum size that could be formed reliably using the hot-needle forming method. Orifices smaller than 1/32 inch tended to close because of "flow" of the molten plastic during retraction of the needle. Therefore,

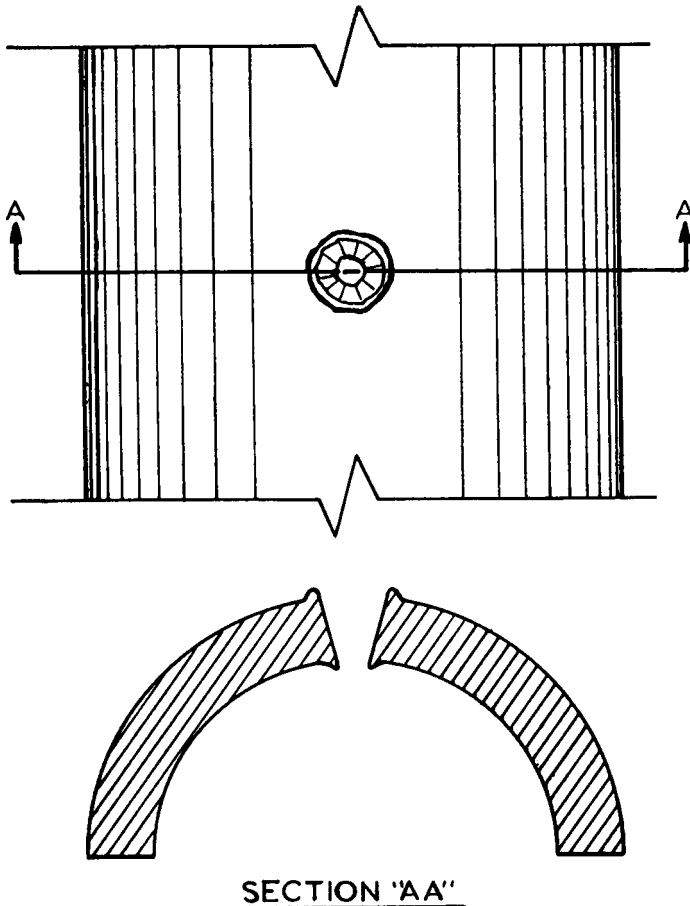

Figure 4. Typical Hot-Needle Orifice

1/32 inch was used as the "standard" orifice size in subsequent system design.

The following settings and adjustment were used in forming orifices with the tapered needle: (1) heating element voltage, 12.5 volts, (2) timer (to hold needle in orifice forming position), 2 seconds, (3) penetration depth, as necessary to obtain desired orifice diameter. With this set-up orifices could be formed without delay to allow the needle point to reheat; i.e. the needle point reheated to a satisfactory working temperature in the time required to advance the pipe the desired orifice spacing. Advancement was by hand. Design numbers 1 and 2 in Figure 3 required an increased interval between forming operations to allow the points to reheat.

The basic elements of this method could be refined so that orifices could be formed as the pipe is being manufactured or as it is installed in the field. It would be possible to redesign the device to include a rotating wheel on which several heated needles are mounted, to allow continuous feeding.

Coefficient of Discharge Determination

The general formula used for relating orifice discharge rate to orifice area and head is: Q equals CA times the square root of $2gH$,

where

Q = discharge rate, volume per unit time

A = area of orifice opening

g = Newtonian constant

H = pressure head

C = dimensionless constant ($0 < C < 1$), which varies with fluid characteristics and orifice configuration and is commonly referred to as coefficient of discharge.

This relationship was used in determining the coefficients of discharge for orifices produced by the heated-needle and the drilling methods. Results were reported by Hoskyn and Bryan, 1967 (7) and are reproduced in Table 2.

As shown in Figure 4, the orifices formed by the heated needle were in general quite irregular in shape. This made it difficult to determine their exact area. For the purpose of computing coefficients of discharge the orifices were assumed to be circular.

Statistical analysis showed no significant difference between the discharge coefficients for the two perforation methods at a

Table 2. Mean Discharge Coefficients for Heated Needle and Drilled Orifices

Measure	Perforation method	
	Heated needle	Drilled
Orifice area (inches squared x 10 ⁻⁴)		
1.913	0.39	0.46
4.53	0.37	0.45
7.65	0.35	0.36
11.35	0.40	0.50
Head (pressure per square inch)		
2	0.34	0.49
4	0.35	0.44
8	0.40	0.45
16	0.41	0.39

confidence level of 95 percent. The mean coefficients were 0.44 and 0.37 for the drilled and heated-needle orifices, respectively. The variation of the coefficient of discharge could not be correlated with head and area. Therefore, for the range of head and area investigated, the coefficients of discharge were assumed to be independent of area and head. If a variation in the coefficients did in fact exist, it may have been masked by experimental error and hence a constant coefficient of discharge of 0.37 was used.

Greenhouse Study

In the summer of 1966 a small subirrigation system was installed in a greenhouse on the Delta Substation near Clarkdale. The objective of this study was to investigate: (1) depth of placement, (2) system operating pressure, and (3) orifice reliability. Treatments are described in Table 3.

Treatments were irrigated when soil moisture reached 20 percent of available. Irrigation of treatments 1 to 3 was terminated when free water appeared on the surface; treatment 4 irrigation was terminated when sufficient water had been applied to bring the plot to field capacity.

Table 3. Details of Treatments Used in Greenhouse Study

Treatment no.	Depth of pipe	System pressure
	Inches	Feet of water
1	18	6
2	12	3
3	12	6
4 (check)		Furrow-irrigated

Cotton was grown in a silt loam soil over the system, and a boll count was used as a production indicator. Soil moisture was monitored using gravimetric methods. The results of this system, in terms of total depth of water applied, average soil moisture, and production are shown in Table 4.

Table 4. Water Applied, Average Soil Moisture, and Production Results in Greenhouse Study

Treatment no.	Total irrigation for season	Season av. soil moisture, 0 to 24 in.	Cotton production
	<i>Inches</i>	<i>% of dry weight</i>	<i>No. bolls</i>
1	8.0	22	15
2	1.9	19	32
3	1.7	20	41
4	6.5 ¹	19	24

¹Excluding runoff.

These results indicate that treatment 3 (12-inch depth, 6 foot-head) maintained adequate soil moisture and produced a relatively large number of bolls, while requiring less irrigation water than the other treatments investigated.

It should be noted that these treatments were not replicated. It is possible, therefore, that the differences observed, especially in production, may not be due to treatment effect.

Table 5. Water Application Rates in Greenhouse Study

Treatment no.	System pressure	Rate in irrigation number		
		1	2	3
	<i>Feet of water</i>	<i>Ft³ per hour</i>		
1	6	5.00	4.75
2	3	1.68	0.96	0.80
3	6	2.45	2.61

The changes in application rates (given in Table 5) show that treatments 1 and 3 maintained a fairly constant application rate during the period of operation while treatment 2 exhibited a declining rate. This observation indicates existence of a "threshold" or lower limit operating pressure for a subirrigation system which may be expressed as: Threshold pressure is a function of orifice type, orifice size, water quality, and nature of surrounding soil.

Thus, minute water impurities from inside and soil particles from outside the pipe which may cause orifice stoppages at less than threshold pressure may be of little or no consequence at pressures above threshold. This would seem a valid explanation of why there was a significant reduction in application rate with time for treatment 2 but not for treatments 1 and 3.

From these observations 2 psi was assumed to be the "threshold" pressure for purposes of further investigation.

Whitney and Lo (14) reported that with porous-media type orifices it is possible to maintain a higher flow rate through these devices if the pressure is periodically raised above the normal operating pressure. This "surging" tends to dislodge minute particles and force them through the orifice device. It would seem reasonable to assume that this same procedure might reduce stoppage problems with other types of orifices.

Field Installation

A field subirrigation system was installed in June, 1967, at Van Buren adjacent to the Vegetable Substation. The soil type at that location is a fine sandy loam.

Variables Investigated

Variables selected for investigation in the field subirrigation system were:

(1) Pressure. Two pressures (6 and 10 foot-heads of water) were selected on the basis of results of the pilot and greenhouse studies. These pressures fall within the range of 2 to 5 psi.

(2) Lateral spacing. Two lateral spacings were selected—38 and 76 inches, corresponding to one-row and two-row widths as used in most field row crops.

(3) Orifice spacing. Three spacings of orifices along the lateral were selected—12, 30, and 48 inches. The spacings were selected to bracket the orifice spacing of 2 x pipe depth. This spacing would, assuming a spherical distribution pattern, cause the wetting fronts from adjacent orifices to meet just as the wetting front reached the surface directly above the orifices.

The three factors were arranged in a 3x2x2 factorial design with 4 replications, as shown in Figure 5.

All laterals in all plots were installed at a depth of 12 inches.

TREATMENTS		EXPLANATION OF TREATMENT SYMBOLS		LEGEND
1. P ₁ S ₁ M ₁	7. P ₂ S ₁ M ₁	P - PRESSURE, FT.	S - ORIFICE SPACING, IN.	• VALVE
2. P ₁ S ₁ M ₂	8. P ₂ S ₁ M ₂	P ₁ - 6	S ₁ - 12	○ FLOW METER
3. P ₁ S ₁ M ₃	9. P ₂ S ₁ M ₃	P ₂ - 10	S ₂ - 30	--- PLOT BOUNDARY
4. P ₁ S ₂ M ₁	10. P ₂ S ₂ M ₁	M - PIPE SPACING, IN.	S ₃ - 48	X NEUTRON PROBE ACCESS TUBE
5. P ₁ S ₂ M ₂	11. P ₂ S ₂ M ₂	M ₁ - 38		
6. P ₁ S ₂ M ₃	12. P ₂ S ₂ M ₃	M ₂ - 76		

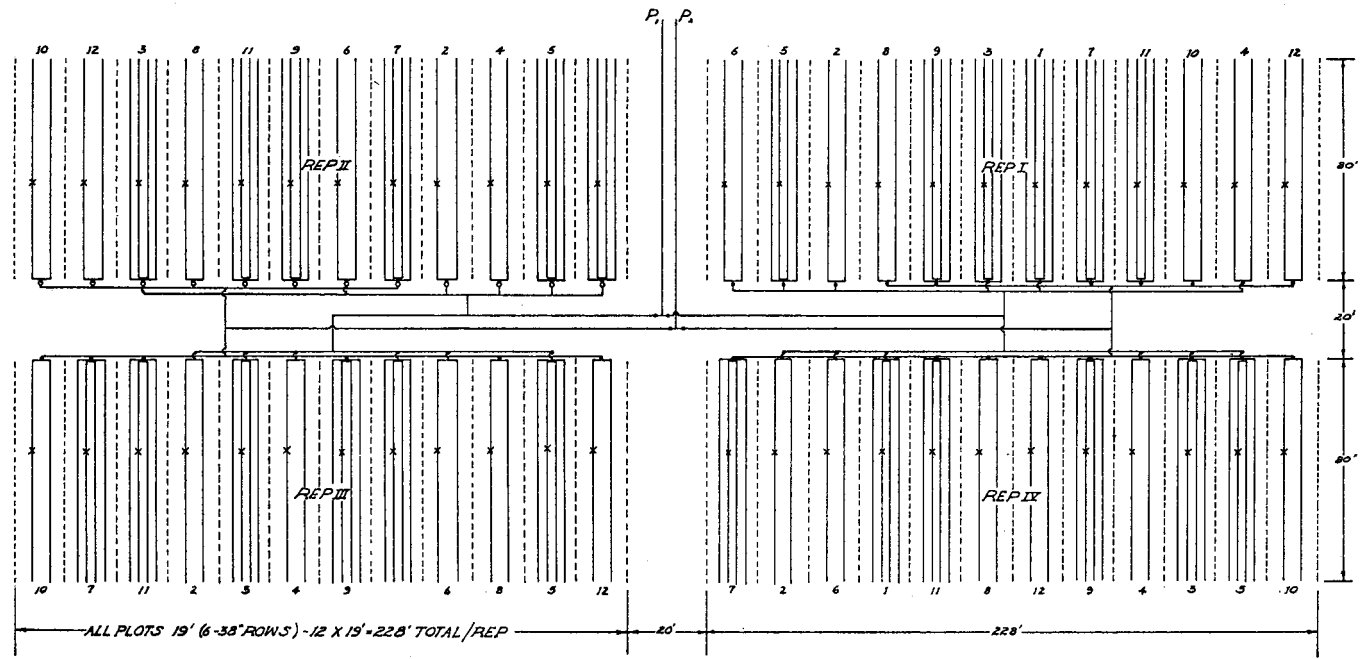

Figure 5. Field Layout of Subirrigation System at Van Buren

This depth is shallow enough to be within or very close to the expected root zone of most crops and yet is deep enough to be below normal tillage operations. It was selected also on the basis of results of the greenhouse study. All main lines and header lines were installed at a depth of 18 inches.

System Description

Twelve treatments were required to investigate all combinations of the variables of pressure, lateral spacing, and orifice spacing. They were replicated four times, making a total of 48 plots, and were randomized within each replication. The plot layout is shown in Figure 5.

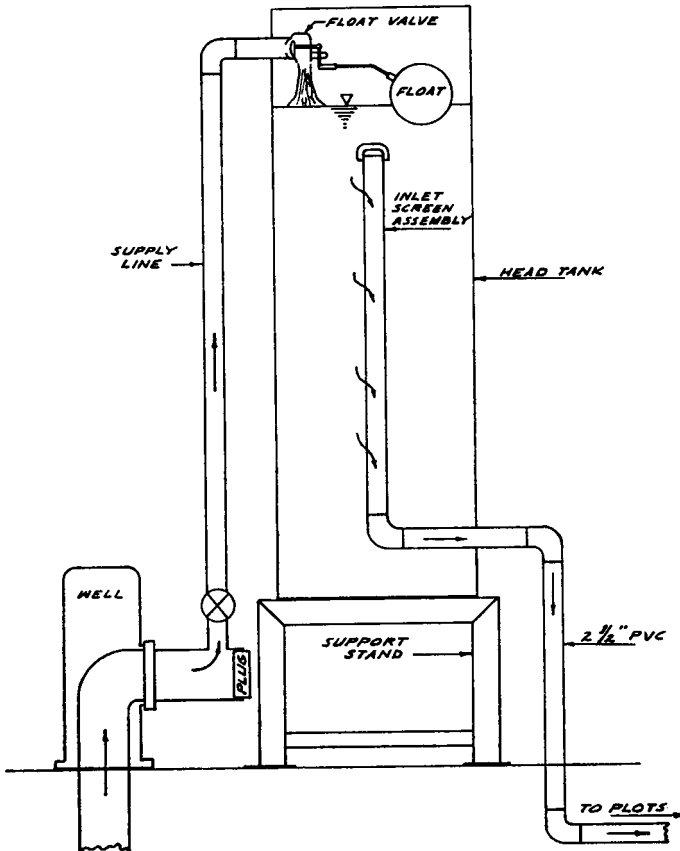

Figure 6. Schematic of Head Tank Assembly

All laterals were of ½-inch polyethylene plastic pipe. Main lines and header lines were sized to minimize head losses and were of either polyethylene or polyvinylchloride plastic.

The schematic of a head tank assembly in Figure 6 shows the path of the water as it flowed from the well through the head tank and finally to the main lines leading to the various plots.

All plots were 6 rows wide including 2 buffer rows, one on each side. The 4 center rows were the test rows. The plots were 80 feet long, and the pipe laterals ran the full length of the plot.

Water meters were installed in replication II to monitor flow rate and volume. Meters were not installed in the other three replications because of cost limitations. The flow rate and volume were assumed to be balanced between all replications because of the system's hydraulic design and the method of operation of the system.

Soil moisture was monitored to a depth of 36 inches with a Nuclear-Chicago model 5810 Subsurface Moisture Probe. This device uses a fast neutron source and a slow neutron detector to measure soil moisture. One access tube for this probe was installed in each plot.

Installation Comments

Trenches were dug with a back hoe for all main lines and header lines. All laterals (½-inch pipe) were installed with an S-shaped pipe-laying device attached to a subsoiler tool (see Figure 7). The pipe was fed through the pipe-laying device from a supply spool mounted above the tractor in front of the operator.

The orifices were preformed in the side of the pipe so that they would be facing to the side, rather than up or down, as the pipe was mounted on the reel during installation. (In Figure 7 the orifices are facing the side of the pipe, which is mounted on the tractor.) This plan met with limited success. Because the pipe had been coiled on the spool it had taken a "set". As the pipe passed through the S-curve in the pipe-laying tube it tended to twist because of this "set," resulting in rotation of the orifice orientation plane. Therefore, it is uncertain how many orifices actually were oriented in the desired direction.

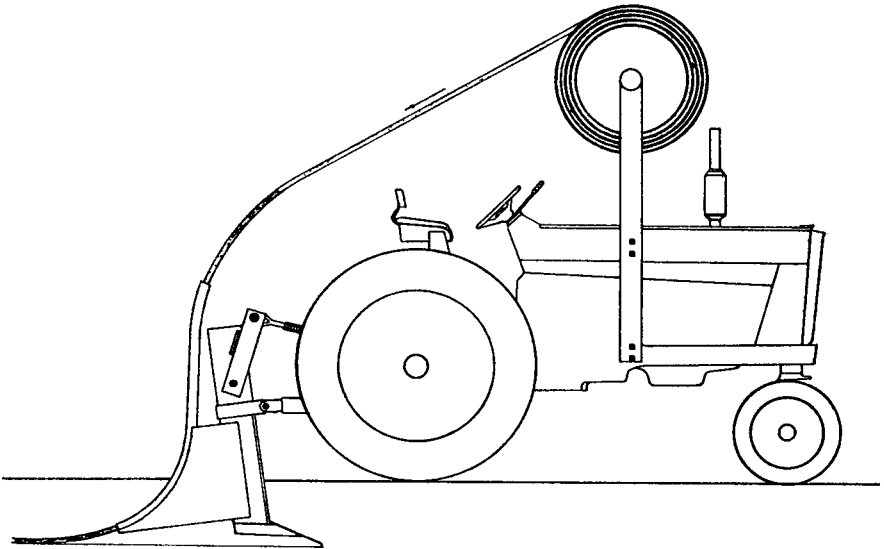

Figure 7. Side View of Pipe-Laying Device

To prevent this twisting, the supply spool should be located above and behind the subsoiler so that pipe could feed from the top of the spool through the tube without reversing the "set" in the pipe.

All connections in the polyethylene plastic pipe were made with standard slip-type plastic fittings with clamps.

System Operation

Soybeans were grown over the system during the summers of 1967 and 1968, and spinach was grown during the spring of 1968. Both the soybeans in 1967 and the spinach in 1968 were lost because of weather difficulties. All data presented on the field installation are for the 1968 soybean crop season.

Soil moisture was monitored at least twice a week and before and after irrigation applications. Irrigation applications were initiated when the soil moisture level of the 0 to 18-inch soil depth (average of the 6-inch and 12-inch readings) of the four replications dropped to 16,000 counts per minute (CPM). This approximates 50 percent available moisture. Irrigation was terminated when free water appeared on the surface. Treatments were not irrigated again until after the second subsequent reading

of the access tubes, or the first reading following a rainfall, indicated moisture had dropped to 50 percent available.

During irrigation application all replications of a given treatment were irrigated at the same time. This procedure, along with the system design, assured equal application to all replications of the same treatment. However, this assumption of equal flow to all replications of a given treatment is subject to error because of (1) elevation differences between replications, (2) unequal magnitude of orifice stoppage (there is no reason to expect a higher incidence of orifice stoppage in any one replication), and

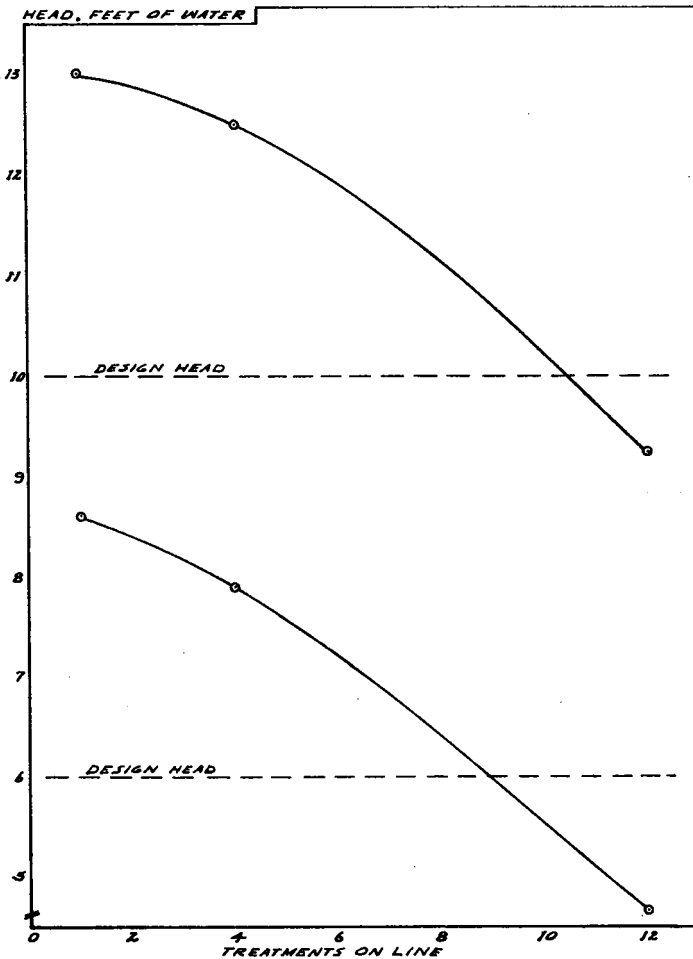

Figure 8. System Pressure Measurements in the Field Study

(3) variation of coefficients of discharge (this should be a random error and would not logically be biased to any particular replication).

Actual System Pressure

After the system was installed a series of tests were conducted to determine actual pressures with various flow rates at the end of the most distant treatment in each replication. The first measurement was made with only one treatment flowing in replication 1. The next two measurements were made with one treatment and then three treatments flowing in each replication. These measurements of pressures are plotted in Figure 8. The last measurement (3 treatments per replication for a total of 12) represents the maximum design flow rate, because no more than 12 plots were ever operating at any one time.

Once the system became operational the water level was not changed in the two head tanks; therefore the exact head available during a specific irrigation depended upon which and how many treatments were being irrigated at that particular time.

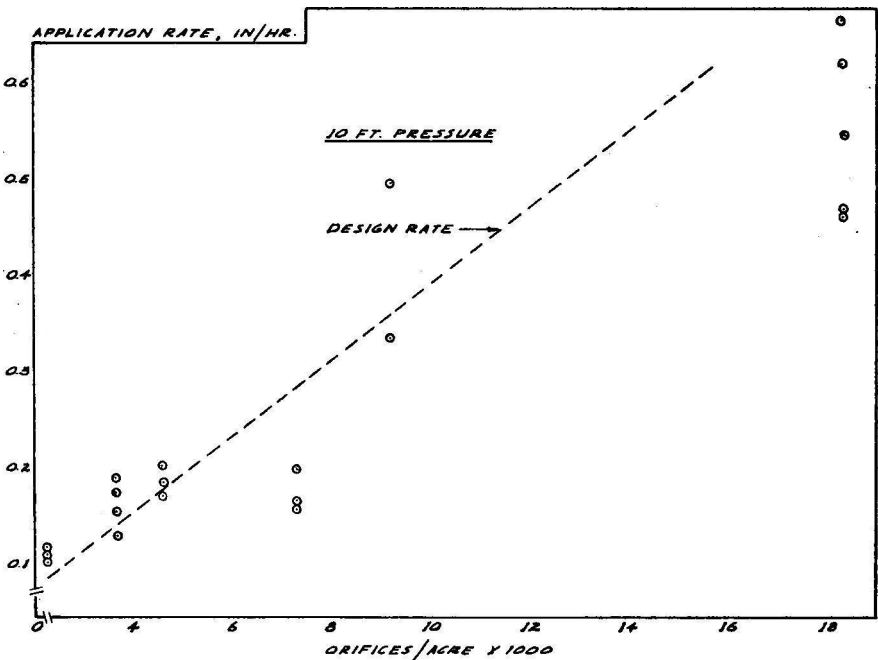

Figure 9. Actual Application Rates Achieved with 6-Ft. Pressure in 1968

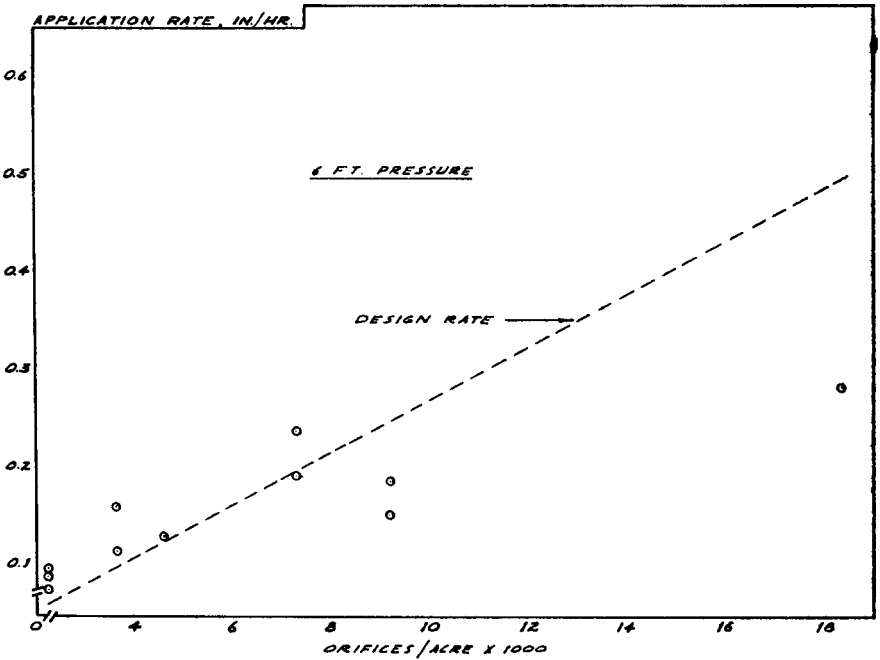

Figure 10. Actual Application Rates Achieved with 10-Ft. Pressure in 1968

Application Rate

The actual application rates achieved during the 1968 season are shown in Figures 9 and 10. During the early part of the season a severe reduction in application rate was experienced as a result of an almost complete plugging of the screen assembly in both head tanks. The plugging was evidently caused by iron bacteria and/or iron precipitate material. Some of this material passed the screen assembly and no doubt was responsible for some if not all of the orifice stoppage problems experienced in this installation. The screen assembly was replaced.

Water Quality

Nothing is more important to the longevity of a subirrigation system than maintaining quality of the water being pumped through the system. Problems of internal orifice stoppages resulting from water impurities have been reported by several researchers in subirrigation (10, 11, 14).

Orifice stoppage was experienced in this installation, the

extent of which was not determined. It was observed, however, that plugged orifices could be reclaimed by flushing. This was observed by exposing several short lengths of pipe in a number of plot laterals. The orifices in some of these sections were either plugged completely or flowing at a reduced rate. Removing the end plug on the affected laterals and allowing the water to flow freely through the pipe for a few minutes resulted in almost complete recovery of flow through the previously plugged or restricted orifices.

In order to identify the problem material in the water, analysis was made of samples taken where the water enters the head tank, in the head tank, and from a lateral pipe line. Only iron content was found to be changed. The iron content in these samples was 0.17, 0.10, and 0.05 ppm, respectively; i.e., iron content decreased as the water moved through the system. Particles of iron precipitate were observed in the head tank, and in the plot laterals during flushing. Therefore, it was concluded that orifice stoppages resulted primarily from iron precipitate.

It was concluded that iron impurities in the water caused internal orifice stoppages, and that orifice flow may be reestablished by flushing a system.

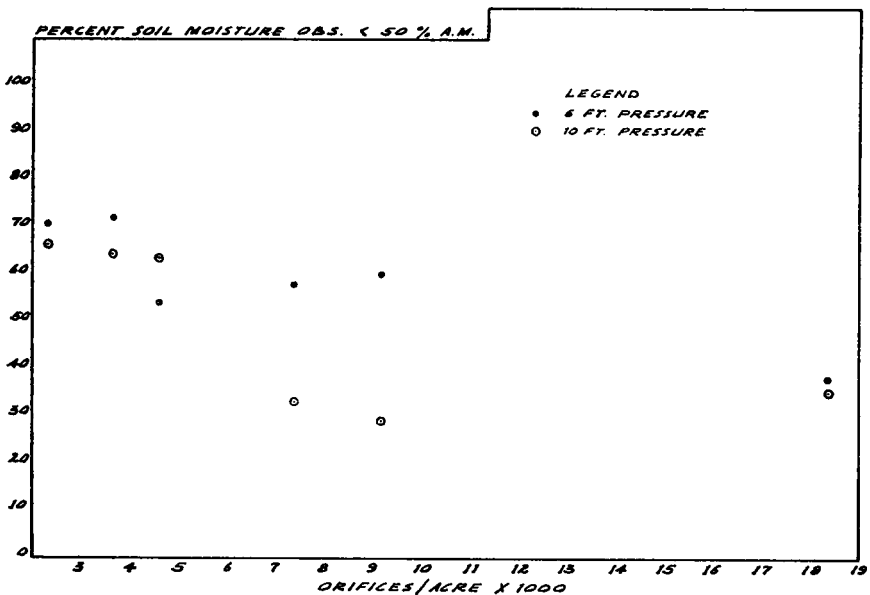

Figure 11. Percent of Soil Moisture Observations Less Than 50% A.M. Versus Number of Orifices per Acre

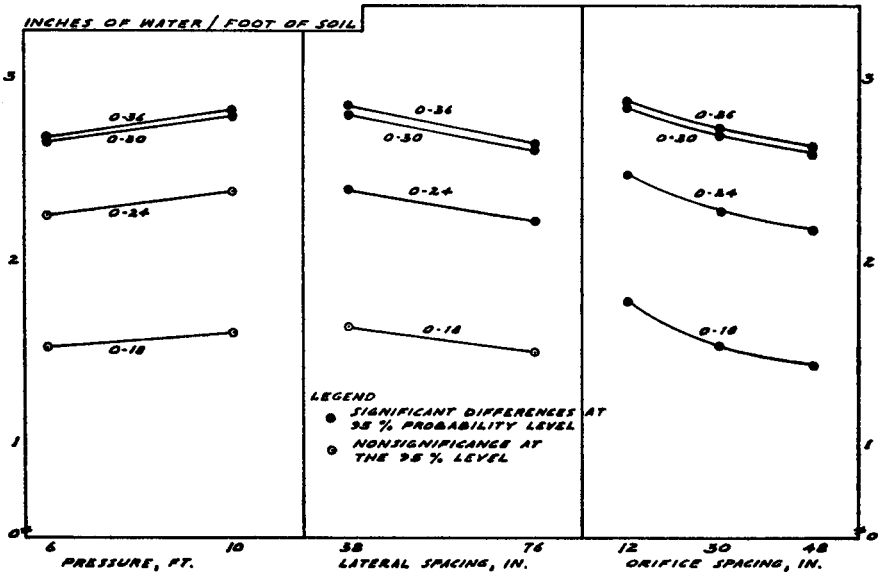

Figure 12. Seasonal Soil Moisture as Related to System Variables

Soil Moisture Levels

One index used to evaluate the system was seasonal average soil moisture levels in the various treatments. Figure 11 shows the percent of soil moisture observations that were less than 16,000 CPM versus the number of orifices per acre. The soil moisture observations are the average of the 6- and 12-inch average readings. It can be seen that soil moisture is maintained at a higher level by a higher orifice density. It is important to remember that the same criteria were used for initiating and terminating irrigation for all treatments.

From the standpoint of seasonal soil moisture levels for the variables under investigation the following results are noted (Figure 12) using the 0 to 24-inch depth as the critical profile depth:

- (1) There was no significant difference in soil moisture levels for the 6- and 10-foot system pressures. Observation of the system during operation revealed no noticeable channeling at the 6-foot pressure, while some channeling was observed in plots supplied at the 10-foot pressure. There was no noticeable decrease in application rate during the season for either pressure.
- (2) There was a significant difference, at the 95% probability

level, in soil moisture levels in relation to lateral spacing. The 38-inch spacing maintained a significantly higher level than the 76-inch spacing.

(3) There were significant differences in soil moisture levels attributable to orifice spacing. However, while the 12-inch spacing yielded higher moisture levels, its cost is 2.5 times as much as a 30-inch spacing. It is questionable whether the increased moisture level from the closer spacing justifies the additional cost.

System Automation

No concentrated effort was made to automate the subirrigation systems in this study. It was felt that enough variables were involved, and that adding experimental automation devices would unnecessarily complicate the systems and the analyses.

A cursory review was made of available devices that could be assembled into an automatic control system. It was concluded that there is now available a selection of valves, time clocks, engine controllers, etc., which could be successfully assembled into a feasible automatic control system with one notable exception — a dependable moisture-sensing device, operable over a sufficiently wide range of soil moisture tensions, that does not drift out of calibration.

SUMMARY AND CONCLUSIONS

A pilot study conducted in 1963 indicated that (1) cotton yields could be increased by subirrigation, (2) drilled orifices were unsatisfactory because of internal plugging caused by burrs and drilling particles, and (3) operating pressures of 5 and 10 psi were excessive, and 5 psi probably should be considered as an upper-limit pressure.

A greenhouse study of a subirrigation system indicated that 2 psi should, in general, for in-wall orifices, be considered as a lower-limit pressure when orifices are built into the pipe wall. The greenhouse study also indicated that a placement depth of 12 inches was preferable to 18 inches in terms of the amount of water required. Twelve inches was used as the depth of placement for the field subirrigation system.

A device was developed for forming orifices with a hot needle. This method has advantages over the drilled orifices used in the pilot study in that the forming process does not produce loose particles to fall inside the pipe or burrs which remain attached to the inner edge of the orifice and later cause stoppage problems. This method also seems preferable to punched orifices which tend to become smaller with time due to rebound of the plastic.

An orifice diameter of 1/32 inch was the minimum size that could be formed reliably using the hot-needle forming method; orifices smaller than 1/32 inch tended to close during retraction of the needle due to "flow" of the molten plastic. Therefore, 1/32 inch was used as the "standard" orifice size in subsequent system design.

A field installation was completed in June, 1967, to investigate combinations of pressure, lateral spacing, and orifice spacing. Weather difficulties were encountered in 1967 and operational experience was gained only during the 1968 season.

Seasonal average soil moisture levels differed significantly. From the standpoint of seasonal soil moisture levels and from observations of the system in operation, the following conclusions are drawn regarding preferable system-operating pressure, lateral spacing, and orifice spacing: (1) a pressure head of 6 feet of water is preferable to 10 feet, (2) 38-inch lateral spacing is preferred over 76-inch spacing, and (3) an orifice spacing of 30 inches is preferable to a spacing of either 12 or 48 inches.

Internal plugging of orifices because of poor quality water was evident. The problem constituent of the water was iron, which was oxidized and precipitated as the water moved through the system, i.e. the precipitate accumulated in the system causing orifice stoppage. Flow from plugged orifices could be re-established by flushing the plot laterals. It is recommended that subirrigation designs provide for adequate treatment of supply water and for periodic flushing of the entire system. The system also should include facilities for periodically applying a higher-than-normal pressure in order to "purge" the system. This would also facilitate flushing.

Although no concerted effort was made to automate the systems investigated, it was concluded that a sufficient selection of valves, timers, engine motor controllers, etc., is available from which to form a feasible automatic control system with the exception of a soil moisture-sensing device that is operable over a sufficiently wide range of soil moisture tensions and does not drift out of calibration.

LITERATURE CITED

1. Braud, J. J. Jr., "Discharge of water through slits in polyethylene plastic pipe," La. Agr. Expt. Sta. Bul. 615, Feb. 1967.
2. Bryan, B. B., and G. Baker. "Small diameter plastic pipe for use in subirrigation," Arkansas Farm Research, XIII(6):7, November-December, 1964.
3. Busch, C. D., and W. R. Kneebone. "Subsurface irrigation with perforated plastic pipe," ASAE Paper 65-203, ASAE, St. Joseph, Michigan, 1965.
4. Davis, S. "Subsurface irrigation how soon a reality?" Agricultural Engineering, Vol. 48, No. 11, ASAE, St. Joseph, Michigan, 1967.
5. Frevert, R. K., G. O. Schwad, T. W. Edminster, and K. K. Barnes. Soil and Water Conservation Engineering, John Wiley and Sons, Inc., New York, 1955.
6. Hanson, E. G. and B. O. Williams. "Influence of subsurface irrigation on cotton yields and water use," ASAE Paper 68-760, ASAE, St. Joseph, Michigan, 1968.
7. Hoskyn, J. P. and B. B. Bryan. "Discharge through plastic pipe orifices," Arkansas Farm Research, XVI(1):7, January-February, 1967.
8. Israelsen, O. W. Irrigation Practices and Principles, John Wiley and Sons, Inc., New York, 1950.
9. Kruse, E. G., P. E. Schleusener, W. E. Selby, and B. R. Somerhalter. "Sprinkler and furrow irrigation efficiencies," Agricultural Engineering Vol. 43, No. 11, ASAE, St. Joseph, Michigan, 1962.
10. Mitchell, W. H., J. E. McIlvaine, and J. P. Mueller. "Subsurface irrigation with perforated plastic tubing," Del. Agr. Ext. Serv. Bul. 99, 1969.
11. Nelson, S. D., S. Davis, and W. V. Pugh. "Root development of citrus trees and potato plants with subsurface irrigation system," ASAE Paper 68-761, ASAE St. Joseph, Michigan, 1968.
12. Pira, E. S., L. F. Whitney, C. M. Vaziri, and L. F. Michelson. "Water distribution from pressurized subsurface irrigation systems," ASAE Paper 65-204, ASAE, St. Joseph, Michigan, 1965.
13. Renfro, G. M. Jr. "Applying water under the surface of the ground," Yearbook of Agriculture, U. S. Dept. of Agriculture, 1955.
14. Whitney, L. F. and K. M. Lo. "Plastic orifice inserts for subsurface irrigation," ASAE Paper 68-758, ASAE, St. Joseph, Michigan, 1968.
15. Zetsche, J. B. Jr. "Evaluation of subirrigation with plastic pipe," ASAE Paper 64-731, ASAE, St. Joseph, Michigan, 1964.