

DEVELOPMENT OF A NATURALLY-VENTILATED SOLAR ENERGY-ASSISTED MAIZE SEED STORE

SIPHIWE MDLALOSE

Submitted in partial fulfilment of the requirements for the degree of

MSc Eng (Agricultural Engineering)

College of Agriculture, Engineering and Science

University of KwaZulu-Natal

Pietermaritzburg

January 2018

Supervisor: Professor TS Workneh

Co- Supervisors: Professor MD Laing and Mr S Sibanda

ABSTRACT

The seed industry continues to face losses during seed storage, especially in Africa. Moreover, there is high loss of seed viability during storage, mainly due to the poor ventilation in seed storage structures, which results in the development of storage fungi. In this study, the main objectives were to construct, to evaluate the solar energy assisted maize seed store. A 22-m³ room was converted to a seed storage room by retrofitting a chimney on its wall and a solar collector on its roof. Different chimney sizes were investigated in order to identify which size would be best for the construction of a naturally-ventilated seed storage room. The chimney sizes that were used included those with a diameter and a height of 200 mm x 3600 mm, 200 mm x 4800 mm, 300 mm x 3600 m and 300 mm x 4800 mm. The parameters, air velocity in the chimney duct, as well as the air temperature and relative humidity at the inlet, centre and outlet of the storage room, were recorded during the seed storage period. A naturally-ventilated seed storage room was developed based on the results obtained. A naturally-ventilated seed storage room was then evaluated in terms of its effectiveness to preserve the quality of the stored maize seeds. To compare the performance of the modified storage room, a room with similar storage capacity, but without the retrofitted components, was used as a control. Maize seeds were stored in each storage room for the duration of three months. Samples were taken every two weeks for germination, moisture content and seed vigour analyses. Both the diameter and height of the chimney were found to have a significant ($P \leq 0.05$) influence on the air ventilation rate inside the storage room. A seed storage was therefore developed using a 300 mm x 4.8 m chimney size, which performed better than the other chimney sizes that were explored in this study. The relative humidity in the control storage room was significantly ($P \leq 0.05$) higher ($60.6 \pm 5.87\%$) than the relative humidity in the modified storage room ($40.1 \pm 3.21\%$). The moisture content obtained in the control room was significantly ($P \leq 0.05$) higher (13.3%) than the moisture content obtained in the modified storage room (12.6%). The initial germination was 99%. The seed germination percentage obtained after three months of storage in the modified storage room was significantly higher ($P \leq 0.05$) ($98.5 \pm 0.85\%$) than the germinations percentage obtained in the control storage ($96.8 \pm 1.49\%$). The seed vigour obtained in the modified storage was significantly higher ($P \leq 0.05$) than the seed vigour obtained in the control room. Thus, a naturally-ventilated seed storage room was tested and was found to preserve the quality of the seeds over the duration of storage.

DECLARATION - PLAGIARISM

I, Sipiwe Nduduzo Mdlalose, declare that:

- (i) The research reported in this thesis, except where otherwise indicated is my original work.
- (ii) This document has not been submitted for any degree or examination at any other university.
- (iii) This document does not contain other persons' data, pictures, graphs or any other information unless specifically acknowledged as being sourced from other persons.
- (iv) This document does not contain other persons' writing, unless specifically acknowledged as being sourced from other researchers. Where other written sources have been quoted, then:
 - (a) their words have been re-written, but the general information attributed to them has been referenced;
 - (b) Where their exact words have been used, their writing has been placed inside quotation marks and referenced.
- (v) Where I have reproduced a publication of which I am an author, co-author or editor, I have indicated, in detail, which part of the publication was written by myself alone and have fully referenced such publications.
- (vi) This document does not contain text, graphics or tables copied and pasted from the Internet, unless specifically acknowledged, and the source being detailed in the thesis and the References sections.

Student: Sipiwe Mdlalose.....Date.....

Supervisor: Prof Tilahum Workneh.....Date.....

Co-supervisor: Prof Mark Laing.....Date.....

Co-supervisor: Mr Sipho Sibanda.....Date.....

ACKNOWLEDGEMENTS

I would like to thank my Supervisors, Prof Tilahun S Workneh, Prof Mark Laing and Mr Sibanda, for their support throughout my research work. I would also like to thank the technical staff of the Agricultural Engineering Workshop at the Ukulinga Research Farm and the Department of Plant Pathology, Mr M Nxumalo, Mr A Hill, Mr I Doidge, Susan van der Merwe and Mr Zuma. I would also like to thank students who helped me at Ukulinga, Steven Cossa and Zama Mbhamali, as well as the postgraduate students, Francis Muga, Tinashe Dirwai, Kipchumba Cheron, Sabelo Shezi, Mubanga Chisenga, Getachew Tolesa and Daniel Otim, for their input in my work. I thank the Bioresources Engineering and Environmental Hydrology staff and students for their support. A special thanks to Dr Rebekca Malinga for motivating me to pursue my career with great passion. Lastly, I would like to thank my parents, Mr G and Mrs N Mdlalose, as well as my siblings and friends for their endless support. *Wayisusa uzoyimela!*

SUPERVISORS' APPROVAL

Subject to the regulations of the School of Engineering, we the Supervisors of the candidate, consent to the submission of this dissertation for examination.

Supervisor: Prof TS Workneh.....Date.....

Co-supervisor: Prof Mark Laing.....Date.....

Co-supervisor: Mr Sibanda.....Date.....

TABLE OF CONTENTS

	Page
DECLARATION - PLAGIARISM	iii
ACKNOWLEDGEMENTS	iv
SUPERVISORS' APPROVAL	v
LIST OF FIGURES	x
LIST OF TABLES	xii
LIST OF ABBREVIATIONS	xiii
1. INTRODUCTION	1
1.1 References	2
2. LITERATURE REVIEW	6
2.1 Seed Properties	6
2.1.1 Seed germination	6
2.1.2 Seed vigour	6
2.2 Testing Seed Quality	7
2.3 Seed Moisture	7
2.4 Psychrometric Moist Air Properties in the Seed Storage Facility	8
2.4.1 Relative humidity	8
2.4.2 Humidity ratio	9
2.4.3 Vapour pressure	10
2.4.4 Dry bulb temperature	10
2.4.5 Wet bulb temperature	11
2.4.6 Dew point temperature	11
2.4.7 Enthalpy	12
2.4.8 Specific volume	12
2.5 Physics of Condensation	12

2.6	Natural Ventilation by the Wind.....	13
2.7	Facilitating Ventilation Using a Chimney	14
2.8	Mechanical Ventilation	15
2.8.1	Mechanical ventilation using fans	16
2.8.2	Cooling systems	16
2.9	Available Renewable Energy Sources	17
2.9.1	Solar energy availability	17
2.9.2	Wind energy availability in Africa	17
2.10	Components of a Seed Storage Room.....	18
2.10.1	Chimney outlet configurations.....	18
2.10.2	Roof of a seed storage room	19
2.10.3	Air channel height.....	19
2.10.4	Seed storage containers.....	20
2.10.5	Packing seed bags for efficient flow of air in between them.....	20
2.11	Discussion	21
2.12	Conclusions.....	22
2.13	References	23
3.	DEVELOPING A SEED STORAGE ROOM THROUGH THE ALTERATION OF DIFFERENT CHIMNEY SIZES	33
3.1	Introduction.....	33
3.2	Materials and Methods.....	36
3.2.1	Experimental site and climatic data	36
3.2.2	Seed storage facility description	36
3.2.3	Solar collector	37
3.2.4	Shelf for seed bags	37
3.2.5	Experimental units	37

3.2.6	Data collection	38
3.3	Data Analysis	38
3.4	Results and Discussion.....	38
3.4.1	Velocity in the chimney duct	38
3.4.2	Relative humidity at the inlet.....	41
3.4.3	Relative humidity at the centre	43
3.4.4	Relative humidity at the outlet.....	44
3.4.5	Temperature at the inlet	45
3.4.6	Temperature at the centre	46
3.4.7	Temperature at the outlet	46
3.4.8	Temperature and relative humidity profile at different positions in the storage room	48
3.5	Conclusion	49
3.6	References.....	50
4.	EVALUATING SEED MOISTURE, GERMINATION AND VIGOUR OF THE STORE MAIZE SEEDS.....	54
4.1	Introduction.....	55
4.2	Materials and Methods.....	56
4.2.1	Description of the solar energy-assisted seed storage facility	56
4.2.2	Experimental Layout.....	57
4.2.3	Data collection	58
4.2.3.1	Moisture content determination	58
4.2.3.2	Standard germination	58
4.2.3.3	Seed vigour by Accelerated Ageing Test.....	58
4.2.3.4	Temperature and relative humidity measurements	58
4.3	Data Analysis	59
4.4	Results and Discussion.....	60

4.4.1	Air relative humidity and temperature measured at the centre of the storage facility and inside the bags containing seeds during the day	60
4.4.2	Air relative humidity and temperature at the centre and in the bag containing seeds at night.....	65
4.4.3	Seed moisture content	69
4.4.4	Seed germination	70
4.4.5	Seed vigour	71
4.5	Conclusions.....	72
4.6	References.....	73
5.	CONCLUSION AND RECOMMENDATIONS	78
5.1	Conclusions.....	78
5.2	Recommendations.....	79

LIST OF FIGURES

Figure 2.1	Psychrometric chart (Earle, 2004).....	8
Figure 2.2	Schematic diagram of the solar chimney (Bilgen and Rheault, 2005).....	15
Figure 2.3	Wind speed map in Africa (Archer and Jacobson, 2005)	18
Figure 2.4	Schematic diagram of the solar collector: (1) corrugated fiberglass cover, (Weather2) iron frame, (3) back insulator, (4) air channel (the height between the absorber and the solar collector) (Janjai and Tung, 2005).....	19
Figure 3.1	Research site.....	36
Figure 3.2	Storage facility	37
Figure 3.3	Air velocity in the chimney duct.....	41
Figure 3.4	Inlet air relative humidity	42
Figure 3.5	Air relative humidity at the centre of the storage.....	43
Figure 3.6	Outlet relative humidity	44
Figure 3.7	Temperature at the inlet.....	45
Figure 3.8	Air temperature at the centre of the storage	46
Figure 3.9	Outlet temperature.....	47
Figure 3.10	Temperature profile at different positions in the storage room.....	48
Figure 3.11	Relative humidity profile in different positions of the storage room.....	49
Figure 4.1	Picture (a) on the left shows the modified storage and picture (b) on the right shows the solar collector system for heating incoming air.	57
Figure 4.2	Experimental design.....	57
Figure 4.3	Seed bags in the storage	59
Figure 4.4	In position 7, (chimney duct) is where the air flow velocity is measured, whereas, in points-2 (inside seed bags), 3 (room centre), 4 (outlet) and 6 (air inlet) is where temperature/relative humidity is measured, respectively at $x = 1.57$ m.....	59
Figure 4.5	The temperature at the centre of the control room and modified room, during the day	61

Figure 4.6	Air relative humidity at the centre of the control room (CR) and modified room (AF) during the day.....	63
Figure 4.7	The temperature of the seeds in the bag in the control room and in the modified room during the day.....	64
Figure 4.8	Seed bag air relative humidity for control room (CR) and modified room (AF) during the day.....	65
Figure 4.9	Centre temperatures for control room (CR) and modified room (AF) during at night.....	66
Figure 4.10	Centre air relative humidity for control room (CR) and modified room (AF) during at night.....	67
Figure 4.11	Seed bag temperature for control room (CR) and modified room (AF) at night.....	68
Figure 4.12	Seed bag air relative humidity for control room (CR) and modified room (AF) during at night.....	69
Figure 4.13	Seed moisture content.....	70
Figure 4.14	Seed germination percentage during the period of storage.....	71
Figure 4.15	Seed vigour.....	72

LIST OF TABLES

Table 2.1	Mean temperatures and relative humidity during the period of the study (after Mettananda <i>et al.</i> , 2001).....	20
Table 3.1	The results of the inlet, centre and outlet temperature, relative humidity and velocity as a result of different chimney sizes	40
Table 4.1	The summary of results of temperature and relative humidity in the centre and inside the seed bags, moisture content, germination and seed vigour in the control and modified room	61

LIST OF ABBREVIATIONS

AA =Accelerated Aging

ACH = air change per hour

AF = Storage facility with chimney induced air flow.

CFD = Computational Fluid Dynamics

CR =control room

EMC = Equilibrium Moisture Content

RH = Relative humidity

1. INTRODUCTION

Seed health and seed vigour must be maintained during storage, in order for seeds to germinate. This is a vital part of agriculture for farmers, seed companies and plant breeders. Seed germination and vigour are dependent on the seed storage environment, especially, the temperature and air relative humidity (Mbofung *et al.*, 2013; Moncaleano-Escandon *et al.*, 2013; Sharma *et al.*, 2013; Suleiman *et al.*, 2013; Kauth and Biber, 2015). A safe seed storage facility should protect seeds against invasion by beetles, weevils, moths, and rodents invasion (Kartikeyan *et al.*, 2009; Nukenine, 2010; Fintrac, 2016). The seed storage environments in Africa are conducive to fungal infection (Gnonlonfin *et al.*, 2013; Dubale *et al.*, 2014), and hence, the maintenance of proper storage conditions is a challenge (Govender *et al.*, 2008). Poor ventilation in a storage structure contributes to a poor storage micro-environment (Kovac and Vojtus, 2015). It is necessary to improve the existing storage systems, so that they will conserve the quality of the seeds at a level that is acceptable to the farmer (Adejumo and Raji, 2007; Chattha and Lee, 2014). Several authors (Adejumo and Raji, 2007; Befikadu, 2014; Chattha and Lee, 2014) have identified the problems encountered in the traditional storage facilities in Africa. Some of the problems are due to structural defects, which cause leaks and condensation on the roof and sidewalls (Chattha and Lee, 2014). These problems result in the loss of viability of the stored seeds. Further studies and improvements are thus required on storage systems in sub-Saharan Africa.

If temperature and relative humidity levels are both high, then the seeds will use up all their nutrient reserves and begin to respire rapidly (Weinberg *et al.*, 2008; Loka and Oosterhuis, 2010; Suleiman *et al.*, 2013). According to the World Food Logistics Organisation (2013), a relative humidity of 20-25% provides a suitable storage environment for most seeds. Legume seeds survive well at a relative humidity below 45-50%, combined with a seed moisture content of 7-10%. A relative humidity below 35-40% is good for storing sorghum seeds. Peanut and tree nut seeds survive well under a 50-65% relative humidity. Increasing the air temperature and consequently lowering the relative humidity of the stored seed is one of the methods of preserving seed viability during storage (Mohammadi *et al.*, 2012). The relative humidity and temperature influence the seed moisture content, seed vigour and germination (Volenik *et al.*, 2006; 2007; Strelec *et al.*, 2010). A high seed moisture content affects germination and seed vigour (Weinberg *et al.*, 2008). Hence, keeping the seed moisture content at a safe level will assist in preserving seed quality.

In principle, seed storage systems operate by allowing air to circulate between the seeds at a controlled temperature and relative humidity, with the purpose of maintaining a desired micro-environment for the stored agricultural products. Air can move naturally, or it can be forced to move through the stored products. Forcing the air to pass between the stored seed is achieved by mechanical means, which includes fans for sucking or blowing air into the storage environment. Conversely, naturally-ventilated storage systems use the wind or a change in temperature to circulate the air and remove moisture from the stored seed (Carl and Hall, 1980; Saa *et al.*, 2012). Natural ventilation is more justified for small-scale farmers across sub-Saharan Africa, since no electricity usage is involved.

Proir to solving the problem of the lack of proper storage conditions for seeds in sub-Saharan Africa, it is important to explore various options of energy sources. For the past 30 years in Africa, the number of people without electricity in rural areas had doubled and it has tripled in urban areas (World-Rufael, 2006). Moreover, there are more than 500 million people without electricity. On the other hand, renewable energy sources are free and good opportunities exist for the use of renewable energy.

This research, therefore, focusses on the development of a naturally-ventilated, solar energy-assisted seed storage room, for use under various agro-climatic conditions. The objectives of this research are:

- (a) to develop a naturally-ventilated solar energy-assisted seed store that lowers the relative humidity inside the storage facility to improve the storage environment and
- (b) to evaluate the quality of seeds stored in the developed seed storage facility in (a), in relation to seed moisture, seed vigour and seed germination.

1.1 References

- Adejumo, BA and Raji, AO. 2007. Technical appraisal of grain storage systems in the Nigerian Sudan savanna. *The CIGR Ejournal* 11(2007):1-11.
- Befikadu, D. 2014. Factors affecting quality of grain stored in Ethiopian traditional storage structures and opportunities for improvement. *International Journal of Basic and Applied Sciences* 18(1):235-257.

- Carl, W and Hall, P. 1980. *Drying and Storage of Agricultural Crops*. AVI Publishing Company, INC., Connecticut, United States of America.
- Chattha, S and Lee, T. 2014. Storage methods and problems of wheat grain at Sindh, Pakistan. *Intl. J. Bioscience* 5(7):260-274.
- Dubale, B, Solomon, A, Geremew, B, Sethumadhava, R and Waktole, S. 2014. Mycoflora of grain maize (*Zea mays* L.) stored in traditional storage containers (Gombisa and sacks) in selected woredas of Jimma zone, Ethiopia. *African Journal of Food, Agriculture, Nutrition and Development* 14(2):1-19.
- Fintrac. 2016. *Smallholder Grain Storage in sub-Saharan Africa*. Report No. 3. Fintrac, Nairobi, Kenya.
- Gnonlonfin, GJB, Hell, K, Adjovi, Y, Fandohan, P, Koudande, DO, Mensah, GA, Sanni, A and Brimer, L. 2013. A review on aflatoxin contamination and its implications in the developing world: a sub-Saharan African perspective. *Food Science and Nutrition* 53(4):349-365.
- Govender, V, Aveling, TAS and Kritzinger, Q. 2008. The effect of traditional storage methods on germination and vigour of maize (*Zea mays* L.) from northern KwaZulu-Natal and southern Mozambique. *South African Journal of Botany* 74(2):190-196.
- Kartikeyan, C, Veeraraghavan, D, Karpagam, D and Firdouse, SA. 2009. Traditional storage practices. *Indian Journal of Traditional Knowledge* 8(4):564-568.
- Kauth, PJ and Biber, PD. 2015. Moisture content, temperature and relative humidity influence seed storage and subsequent survival and germination of *Vallisneria americana* seeds. *Aquatic Botany* 120(2015):297-303.
- Kovac, M and Vojtus, J. 2015. Analysis of air velocity, moisture and thermal regime in an air gap of a double-shell roof. *Energy Procedia* 78(1):759-764.
- Loka, DA and Oosterhuis, DM. 2010. Effect of high night temperatures on cotton respiration, ATP levels and carbohydrate content. *Environmental and Experimental Botany* 68(3):258-263.

- Mbofung, GCY, Goggi, AS, Leandro, LFS and Mullen, RE. 2013. Effects of storage temperature and relative humidity on viability and vigor of treated soybean seeds. *Crop Science Society of America* 53(2013):1086-1095.
- Mohammadi, H, Soltani, A, Sadeghipour, HR and Zeinali, E. 2012. Effects of seed aging on subsequent seed reserve utilization and seedling growth in soybean. *International Journal of Plant Production* 5(1):65-70.
- Moncaleano-Escandon, J, Silva, BCF, Silva, SRS, Granja, JAA, Alves, M and Pompelli, MF. 2013. Germination responses of *Jatropha curcas* L. seeds to storage and aging. *Industrial Crops and Products* 44(2013):684-690.
- Nukenine, EN. 2010. *Stored Product Protection in Africa: Past, Present and Future*. Report No. 10.5073. Ngaoundere, Cameroon.
- Saa, C, Miguez, JL, Moran, JC, Vilan, JA, Lago, ML and Comesana, R. 2012. A study of the influence of solar radiation and humidity in a bioclimatic traditional Galician agricultural dry storage structure (Horreo). *Energy and Buildings* 12(2012):109-117.
- Sharma, S, Kaur, A, Bansal, A and Gill, BS. 2013. Positional effects on soybean seed composition during storage. *Journal of Food Science and Technology* 50(2):353-359.
- Strelec, I, Popovich, R, Ivanišić, I, Jurcovic, V, Jurcovic, Z, Hardi, Z and Sabo, M. 2010. Influence of temperature and relative humidity on grain moisture, germination and vigour of three wheat cultivars during one year storage. *Poljoprivreda* 16(2):20-24.
- Suleiman, RA, Rosentrater, KA and Bern, CJ. 2013. Effects of deterioration parameters on storage of maize. *Journal of Natural Science* 3(9):147-65.
- Volenik, M, Rozman, V, Kalinović, I, Liška, A and Šimić, B. 2006. Influence of relative humidity and temperature on changes in grain moisture in stored wheat and sunflower. *Stored Product Protection* 2(2006):1-6.
- Volenik, M, Rozman, V, Kalinovic, I, Liska, A, Kiš, D and Šimić, B. 2007. Influence of relative humidity and temperature on the changes in grain moisture in stored soybean and maize. *Agriculturae Conspectus Scientificus (ACS)* 72(3):215-219.

Weinberg, ZG, Yan, Y, Chen, Y, Finkelman, S, Ashbell, G and Navarro, S. 2008. The effect of moisture level on high-moisture maize (*Zea mays* L.) under hermetic storage conditions-in vitro studies. *Journal of Stored Products Research* 44(2):136-144.

Wolde-Rufael, Y. 2006. Electricity consumption and economic growth: a time series experience for 17 African countries. *Energy Policy* 34(10):1106-1114.

World Food Logistics Organisation. 2013. Seeds and Vegetable Storage Conditions. [Internet]. World Food Logistics Organisation, Virginia, USA. Available from: <http://www.gcca.org/uploads/2012/09/SeedsVegetable.pdf>. [Accessed: 02 June 2016].

2. LITERATURE REVIEW

This section consists of the literature review on the topic that is currently under study.

2.1 Seed Properties

The properties of seeds, which affect the seed quality, are explained in this subsection.

2.1.1 Seed germination

Conklin and Sellmer (2009) defined germination as a sequential series of morphogenetic events that results in a seedling via embryo transformation. The germination percentage can be computed by using the following formula (Holmer *et al.*, 2012; Sawant *et al.*, 2012; Deepika and Ashok, 2014).

$$\%Germination = \frac{\text{Number of seedling emerged}}{\text{Number of seeds sown}} \times 100 \quad (2.1)$$

The viability of stored seeds is affected by the temperature and relative humidity, coupled with the period of storage. The behaviour of the medicinal perennial herb seeds (*Rheum austral* D Don) was studied under room and refrigerated conditions (0-5°C) for a period of 12 months (Bhardwaj *et al.*, 2014). It was observed that a high viability of seeds was maintained when the seeds were stored under refrigerated conditions. Soya bean seeds achieved a germination percent of 92% after they were stored with an initial moisture content of 8% and at a relative humidity of 50% for 180 days (Ali *et al.*, 2014). For soya beans seeds stored in uncontrolled conditions, the germination percentage was found to be 70% after three months (Kandil *et al.*, 2013). Therefore, the literature shows that good seed viability and vigour can be maintained by maintaining a proper micro-environment in storage facilities.

2.1.2 Seed vigour

The strength and ability of a seed to germinate with success and to develop into a seedling is called seed vigour (Dornbos, 1995). Based on the definition given by the ISTA Vigour Test Committee (1995), (Qi *et al.*, 2011) and the International Rice Research Institute (2013), seed vigour is the sum of those properties of the seed that determine the performance and the level of activity of the seed, or seed lot during germination and seedling development. Seed vigour losses are associated with the reduced ability of the seeds to undergo all physiological processes that will enable them to perform. Physiological ageing (deterioration) begins prior to harvesting and carries on to harvesting, processing and storage (ISTA Vigour Test Committee 1995). Seed

vigour is dependent on the ability of the seed lot to withstand lengthy storage conditions and the harmful effects of ageing during storage (Ventura *et al.*, 2012).

Mbofung *et al.* (2013) evaluated the seed vigour and viability of soya beans after they were stored for 20 months. Evaluations were undertaken every four months under three differing conditions of temperature and relative humidity. The conditions were as follows: a non-climate controlled warehouse (WH), a climate-controlled cold room storage (CS) (10°C and $59.6 \pm 7.3\%$ relative humidity [RH]), and a climate-controlled walk-in germinator or “warm storage” (25°C and $31.2 \pm 11.1\%$ RH) (Román *et al.*, 2009). Two tests were used to determine seed vigour and viability, namely, a standard germination test and an accelerated ageing test. It was concluded that seed vigour and viability were best maintained under both a low temperature and relative humidity.

2.2 Testing Seed Quality

Testing the physiological potential of a seed lot is carried out by using seed vigour and germination tests (Renata and Julio, 2014). Seed vigour tests indicate the stage of seed deterioration during the storage period, and the germination test is only useful for identifying severe seed deterioration. Seed vigour tests are useful during storage, since the reduction in seed vigour occurs before seed viability loss. According to Perveen *et al.* (2010), the best vigour tests are the Germination Index (GI), Electrical Conductivity (EC), and Accelerated Aging (AA) tests. AA is useful for predicting seed longevity (Balešević-Tubić *et al.*, 2010). The procedures for conducting these tests are defined in the International Seed Testing Association (ISTA Vigour Test Committee, 2006) manual.

2.3 Seed Moisture

The FAO (2016) defined seed moisture as the quantity of moisture present in the seed, which is normally articulated as a percentage of its weight. The seed moisture content varies with the relative humidity during storage. In the winter months, it is normally higher than in summer, because of the lower temperatures in winter experienced in the storage room (Elias *et al.*, 2016). Most seeds can be stored below a 14% moisture content and still achieve good longevity (International Rice Research Institute, 2013). However, 6% is reported to be the optimum moisture content during storage (Elias *et al.*, 2016). Osueke (2013) summarised the storage period against safe storage seed moisture as follows: for, 2-3 weeks, 8-12 months, and > 1 year of storage the suitable seed moisture is 14-18%, 12-13%, and $< 9\%$ wet basis, respectively. This is in agreement with the study done by de Alencar *et al.* (2006), which showed that soya

beans stored at 14.8% moisture content under the temperature and relative humidity of 40°C and 85.3%, respectively preserved the seed quality for 90 days. In summer, it is possible for seeds to reach 10% moisture content naturally (Elias *et al.*, 2016). Moisture content of the seeds increases in winter, since the relative humidity increases. However, the negative effects of a high moisture in storage are reduced by lower ambient temperatures.

2.4 Psychrometric Moist Air Properties in the Seed Storage Facility

Moist air consists of water vapour and dry air (Brooker *et al.*, 1992; Abbas *et al.*, 2010; Shallcross, 2012). Three terms define humidity in the air: relative humidity, humidity ratio and vapour pressure, whereas temperature is defined by the dry bulb, wet bulb and dew point temperatures. There are also two other properties that need to be considered, namely, enthalpy and specific volume. A psychrometric chart defining these terms encountered in the seed store is presented in Figure 2.1. Psychrometric conditions are essential in a storage and drying of agricultural produce (Abbas *et al.*, 2010).

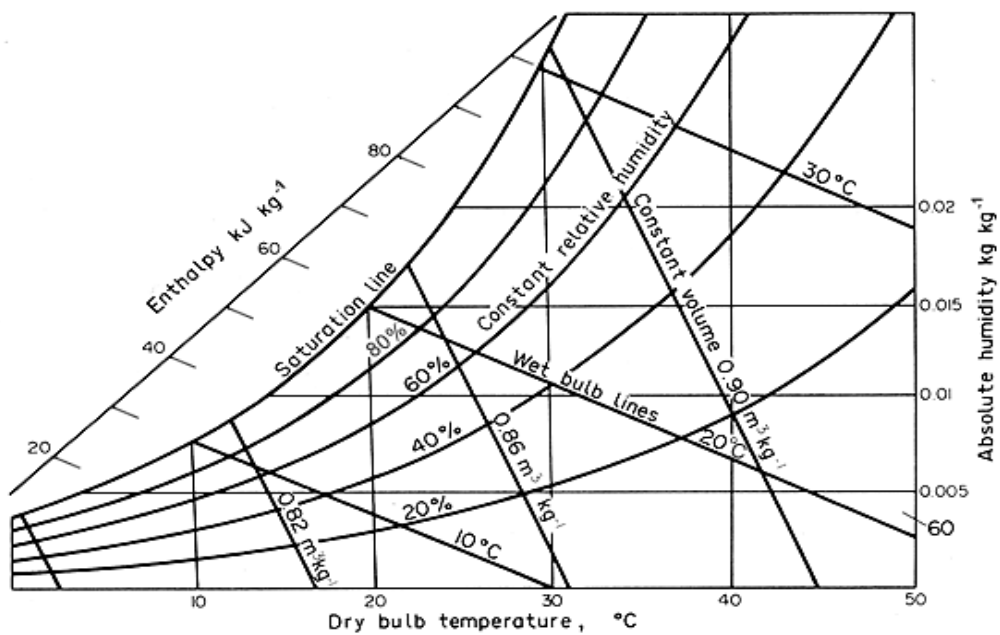

Figure 2.1 Psychrometric chart (Earle, 2004)

2.4.1 Relative humidity

According to Bankole *et al.* (2013) and FAO (2016), relative humidity (RH) is expressed as the ratio of the amount of water vapour in the air to the amount of water vapour that would saturate the air at the same temperature. It is normally expressed as a percentage. A seed must be stored at a relative humidity that is below its equilibrium moisture content. Otherwise, it will gain moisture, and lead to the development of mould (FAO, 2016). The relative humidity

(RH) has a significant effect on the seed moisture content, so that if dry air surrounds the seed, it will lose moisture. Similarly, if wet air surrounds it, it will gain moisture. It will continue until the seed and the surrounding air are in equilibrium, and this state is known as the Equilibrium Moisture Content (EMC). Changes in the temperature and RH induce changes to seed moisture content. Seed moisture is important in determining seed longevity and several other aspects of seed quality (McDonald, 2007).

The relative humidity and temperature are related, because temperature determines the amount of water vapour that the air can hold. Many seeds survive well at a temperature and RH of 16°C and 60%, respectively, which is regarded as a safe storage environment (Elias *et al.*, 2016).

Relative humidity is calculated using Equation (2.2) (Oko and Diemuodeke, 2010).

$$RH = \frac{P_{wv}}{P_s} \times 100 \quad (2.2)$$

where

RH = relative humidity of the air (%),

P_{wv} = partial pressure of water vapour (kPa), and

P_s = saturation pressure of water vapour (Pa).

2.4.2 Humidity ratio

The humidity ratio, which is also known as the absolute humidity or specific humidity, is the mass of water vapour in the moist air per unit mass of dry air (Brooker *et al.*, 1992; Niaz *et al.*, 2011; Shallcross, 2012). The relative humidity for drying ranges from 0.005 kg to 0.2 kg water per kg of dry air. The specific humidity is proportional to the total energy content or enthalpy of the moist air mixture (Kenneth and Elovitz, 1999). A change in relative humidity occurs when moisture is removed or added. On the other hand, temperature does not change the relative humidity unless the air is cooled below the dew point temperature. Some, dehumidification systems employ the principle of reducing RH by condensing water vapour from the surrounding air. In this research, dehumidifying the air would not be an option, due to the costs involved in running a dehumidification system.

Specific humidity (g) is computed by using Equation (2.3) (Oko and Diemuodeke, 2010).

$$g = 0.622 \times \frac{RH}{1-RH} \quad (2.3)$$

2.4.3 Vapour pressure

This is the partial pressure imposed by water vapour molecules in moist air. Saturated vapour pressure occurs when water vapour completely saturates the air (Kenneth and Elovitz, 1999). The vapour pressure that is used for drying is less than 6.9 kPa, which is much lower than the atmospheric pressure (101.3 kPa). For heating, ventilation and air conditioning applications, only the vapour pressure of water in contact with itself is considered. In storage, the vapour pressure is important for determining the water vapour movement from the inter-granular air in the seed to the ambient air, or vice versa (vapour migration). The rate of vapour migration is not directly proportional to an increase in temperature, even though increasing temperature increases vapour diffusion. For maize stored at 14% wet basis moisture content, increasing the temperature from 15 to 25°C and from 25 to 35°C gave the vapour pressure difference (vapour difference between vapour pressure of inter-granular air in the seed and vapour pressure of the ambient air) of 9.2 mm Hg and 15.2 mm Hg, respectively (Carefully to Carry Committee, 2016). Thus, the vapour pressure is important, as it affects the storage of agricultural produce. Equation (2.4) is used to compute vapour pressure (Oko and Diemuodeke, 2010).

$$P_{wv} = \frac{1.8(P_{wv} - P_{(s)wb})(t - t_{wb})}{2800 - 1.3(1.8t + 32)} \quad (2.4)$$

where

t = temperature of the humid air (°C),

t_{wb} = wet bulb temperature (°C), and

$P_{(s)wb}$ = saturation pressure of wet bulb temperature (kPa).

2.4.4 Dry bulb temperature

Temperature that is measured with a normal thermometer is referred to as the dry bulb temperature. For drying, this temperature ranges from 4°C to 287°C. Rubenstein *et al.* (1979) and Nagel and Börner (2010) stated that the storage temperature and seed moisture content are vital factors affecting seed longevity, with the seed moisture content being regarded as the most influential. However, these two factors are interrelated. The interactions of the temperature (25°C or 35°C) and moisture content (10, 12.5, 15.5%) were studied for 18 days on rapeseeds phytosterol (Gawrysiak-Witulaska *et al.*, 2012). It emerged that the temperature, moisture content and storage time all had an effect on the deterioration of these seeds. At a higher temperature and moisture content, a greater loss of seed vigour was observed. Higher

temperatures in the seed storage facility reduce the RH. This is beneficial for seeds that require lower RH to sustain their vigour.

2.4.5 Wet bulb temperature

The psychrometric wet bulb temperature is the moist air temperature that is read by a thermometer, the bulb of which is covered by a wet wick. The velocity of air moving over the wick must be a minimum of $4.6 \text{ m}\cdot\text{s}^{-1}$. As was reported by Ranjbaran and Emadi (2015), wet bulb temperature is vital for controlling the insect population during storage. Wet-bulb temperature is measured in the inter-granular air in the seeds. There is a threshold Commodity Wet Bulb Temperature (CWBT) below which the insect population growth rate is zero (Ranjbaran and Emadi, 2015). Above this temperature, the insect population begins to increase exponentially. The combination of RH and dry bulb temperature, which results in the CWBT, which, in turn, promotes insect population growth should be avoided in seed storage room. The wet bulb temperature is used mostly in evaporative cooling systems, where the minimum temperature achieved by the system is limited by the wet bulb temperature (Hasan, 2010).

The Wet bulb temperature is determined by using Equation (2.5) (Oko and Diemuodeke, 2010).

$$t_{wb} = t - \frac{K_M h_{(fg)wb}}{\alpha_a} (g_{wb} - g) \quad (2.5)$$

where

α_a = heat transfer coefficient of the air film around the wetted surface ($\text{W}\cdot\text{m}^{-2}\cdot\text{K}^{-1}$),

K_M = mass transfer coefficient based on the specific humidity ($\text{kg}_{\text{w.b.}}\cdot\text{m}^{-2}\cdot\text{K}^{-1}$),

$h_{(fg)wb}$ = specific latent enthalpy ($\text{kJ}\cdot\text{kg}^{-1}$), and

g_{wb} = specific humidity (%).

2.4.6 Dew point temperature

Dew point temperature is the temperature that occurs under a constant humidity ratio and atmospheric pressure during air-cooling, it is called the dew point temperature. The dew point temperature is important in dealing with condensation issues during seed storage.

The dew point temperature (T_d) is computed by using Equation (2.6) (Oko and Diemuodeke, 2010).

$$T_d = \frac{237.3 \ln\left(\frac{P_s \times RH}{611}\right)}{7.5 \ln 10 - \ln\left(\frac{P_s \times RH}{611}\right)} \quad (2.6)$$

2.4.7 Enthalpy

The Enthalpy of a dry air water vapour mixture is defined as the heat content of the moist air per unit mass of dry air beyond a particular reference temperature. When drying, enthalpy values range from 23 kJ.kg⁻¹ to 314 kJ.kg⁻¹ of dry air. It will not be considered in this research.

Equation (2.7) calculates enthalpy (Oko and Diemuodeke, 2010).

$$h = C_{p_{da}}t + (2501 + C_{p_{vw}}t) \quad (2.7)$$

where

h = enthalpy (kJ.kg⁻¹),

$C_{p_{da}}$ = specific heat capacity of dry air (kJ.kg.K⁻¹), and

$C_{p_{vw}}$ = specific heat capacity of water vapour (kJ.kg.K⁻¹).

2.4.8 Specific volume

The specific volume of moist air is the volume per unit mass of dry air. The reciprocal of this gives the specific density. Air used for drying has a specific volume that ranges from 0.78 m³.kg⁻¹ to 1.58 m³.kg⁻¹ (Oko and Diemuodeke, 2010). It will not be considered in this research.

Specific volume (v) is determined using Equation (2.8) (Oko and Diemuodeke, 2010).

$$v = \frac{R_{d.a}T}{P_b - P_{wb}} \quad (2.8)$$

where

T = absolute temperature of humid air (K),

$R_{d.a}$ = dry air constant 0.2873 (kJ.kg⁻¹.K⁻¹), and

P_b = barometric pressure (kPa).

2.5 Physics of Condensation

On cold surfaces, condensation occurs when the dew point temperature of the humid air that is in contact with the surface is above the temperature of the surface (Mohammad and Majid, 2013). At first, condensed water vapour appears as a mist on the surface. However, as time progresses, more condensation occurs and the size of the water droplets on the surface increases. When the gravity acting on the droplets exceeds the surface tension that is keeping

the droplets in place, they begin to slide down the surface. This tendency is customarily observed on inclined and vertical surfaces. Condensation in the seed storage structure results in the development of pests, mould, fungi and other micro-organisms (Bankole *et al.*, 2013; Chattha and Lee, 2014). Condensation occurs if a structure is poorly ventilated (Kovac and Vojtus, 2015). However, condensation on the seed surfaces will not occur as long as the temperature on the seed surface is 2°C above the dew point temperature of the ambient air (Song *et al.*, 2008). In the seed storage room, condensation should be avoided, as it is the severe indoor air quality problems (Liu *et al.*, 2004; Chattha and TeangShui, 2014).

2.6 Natural Ventilation by the Wind

Naturally-ventilated structures work on two principles, namely, the thermal convection, or the stack effect, and wind velocity (Pringle and Robinson, 1996; Arce *et al.*, 2009; Khanal and Lei, 2011; Swiegers, 2015). Thermal convection is the consequence of hot air that is generated inside the structure. As a result, hot air is replaced by outside cold air, due to thermal buoyancy. In this way air movement occurs, resulting in ventilation. Wind velocities create ventilation inside the structure, by generating positive pressures on the windward side and negative pressures on the leeward side of the structure. Pressures over low-pitched roofs are negative. Wind towers have been used, in few instances, to improve the ventilation in buildings (Hughes *et al.*, 2012). Courtyards, chimneys and curved roofs that boost the air movement in a building have been widely used.

Wind-driven ventilation is reliant on wind strength and direction. It is sometimes called wind-driven cross-ventilation. For simple cases of wind ventilation, with a single air intake opening and exhaust opening, the air flow is computed by using the following equation (Khanal and Lei, 2011; National Institute of Building Science, 2016):

$$Q = K \times V \times A \quad (2.9)$$

where

Q = air flow rate ($\text{m}^3 \cdot \text{h}^{-1}$),

K = coefficient of effectiveness (dimensionless),

A = area of the opening (m^2), and

V = velocity of the outside air ($\text{m} \cdot \text{h}^{-1}$).

The value of K is dependent on the angle of the wind and the relative size of the inlet and exit openings. The K ranges from 0.4 to 0.8 for wind hitting an opening at incident angles ranging from 45° to 90°, respectively.

2.7 Facilitating Ventilation Using a Chimney

In 1980, the first solar chimney power plant was developed and tested in Manzanares, Spain (Haaf *et al.*, 1983; Waaf, 1984; Bilgen and Rheault, 2005; Zhou *et al.*, 2010). This is one of the examples of the application of the solar chimneys. The plant had a solar collector installed horizontally at a height of 200 m above the ground, it covered an area of 11 000 m² and it had a chimney with a diameter of 10 m. It achieved a power output of 50 kWh in the turbine. Practically, the solar chimney consists of the chimney, the collector system and the turbine (Pretorius and Kröger, 2006). The solar chimney plant operates with ambient air entering the periphery of the collector system and moving towards the chimney (Figure 2.2). As the air moves, it heats up, because the space between the ground and the collector is hot, due to solar radiation. The hot air is drawn to the chimney as a result of the pressure potential created by the difference between the density of warm and outdoor air (the temperature differential effect). The Venturi effect is important in increasing the speed of the air entering the chimney foot, since the area in this region is narrow. The warm air heading to the chimney drives the turbine to generate electricity. Chimneys play a huge role in facilitating the air flow in solar dryers. Fudholi *et al.* (2010) reported that a dryer, with a chimney diameter of 30 cm and height extending 1.9 m beyond the highest point in the drying chamber worked well in the drying of agricultural products. A hemi-cylindrical tunnel dryer, using chimney with a 20 cm diameter achieved a temperature gradient of 10-28°C, which is enough for drying agricultural commodities (Rathore and Panwar, 2010).

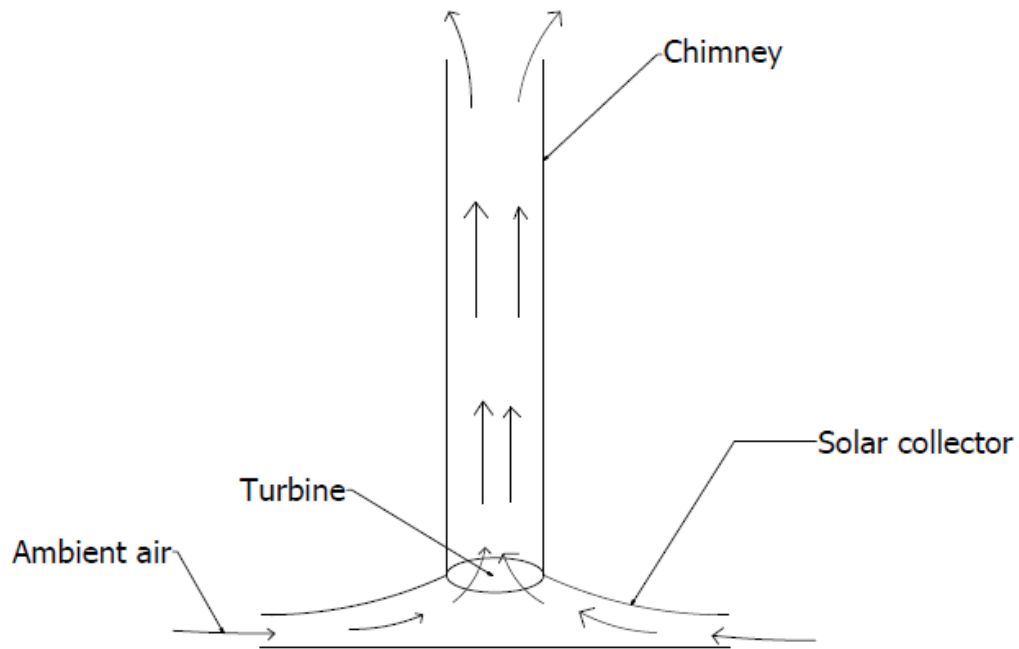

Figure 2.2 Schematic diagram of the solar chimney (Bilgen and Rheault, 2005)

The temperature differential, or stack effect induces the flow of air along the path of least resistance in a vertical direction (Khanal and Lei, 2011; National Institute of Building Science, 2016). The induced volumetric flow rate is calculated by using the following equation:

$$Q = C_d \times A[2gh(T_{in} - T_{out})]^{1/2} \quad (2.10)$$

where

Q = volumetric flow rate ($\text{m}^3 \cdot \text{h}^{-1}$),

$C_d = 0.65$, a discharge coefficient (dimensionless),

A = area of the opening (m^2),

$g = 9.8 \text{ m} \cdot \text{s}^{-2}$, acceleration to due to gravity,

h = vertical height between inlet and outlet midpoints (m),

T_{in} = indoor average temperature (K), and

T_{out} = outdoor average temperature (K).

2.8 Mechanical Ventilation

Mechanical ventilation systems use fans, thermostats and air inlets, and they are required for temperature regulation, for example, in animal houses and storage facilities of agricultural

produce (Grubinger and Sanford, 2015). The approach that is used for mechanical ventilation, is to blow out warm, humid air from the structure and to introduce cool, dry fresh air.

2.8.1 Mechanical ventilation using fans

There are two types of mechanical ventilation systems exist, namely, the exhaust and pressure systems (Grubinger and Sanford, 2015). In the exhaust system, fans create a pressure that is lower than the atmospheric pressure inside the building, so that air from outside the building can enter through inlets and replace the indoor air. In pressure ventilation, fans create a positive pressure inside the building to expel air from inside the building through outlets of the building. Exhaust ventilation systems are popular, since they are less complex and expensive than pressure systems. However, pressure systems are very useful for expelling the dust from buildings with cracks and when continuous recirculation is needed. The application of fans also extends to solar drying systems.

A roof integrated solar dryer forces air to the drying chamber by using an axial fan (diameter = 30 cm) (Janjai *et al.*, 2008). Axial fans are commonly used to suck heated air in the roof solar collector and to distribute it in the drying chamber. Sreekumar (2010) also used the same approach in the design of a solar dryer. Another solar dryer used an axial fan (diameter = 30 cm) to supply air that was heated by the sun to the drying chamber.

2.8.2 Cooling systems

There cooling systems are vital in maintaining cool environment of the stored seeds. The Solar refrigeration system uses solar thermal heat to create the cooling effect (Huang *et al.*, 1998; Sarbu and Sebarchievici, 2013). In principle, it has the solar collectors that absorb solar thermal heat, which is used to drive the cooling machine to produce a cooling effect. Due to high installation costs, the application of this cooling system has been limited. According to Nguyen *et al.* (2001), standard cooling systems utilise vapour compression systems, for instance, chlorofluorocarbon refrigerants (CFC) (R11 and R12). CFCs alone contribute to global warming, since they deplete the ozone layer when discharged to the atmosphere and this has a negative environmental impact.

Attempts to reduce the environmental impact of CFCs have resulted in them being replaced by hydro chlorofluorocarbon refrigerants (HCFC) (R134a). However, HCFCs have been found to have the same environmental impact as CFCs.

An evaporative cooling system has evaporative cooling pads, a water supply system and fans (Chen *et al.*, 2010). Water is usually supplied to the cooling pads, using a pump, in order to wet them. Fans are used to evaporate water from the cooling pads, either by blowing, or by sucking air across the pads, to create an evaporative cooling effect.

Khanal and Lei (2011) reported that mechanical ventilation has undesirable energy implications, since it needs more electricity to operate it. Regarding energy savings on an annual basis, natural ventilation provides savings on cooling, in the order of 10% and 20% of fan power.

2.9 Available Renewable Energy Sources

Renewable energy is a source of energy that is not depleted when used, for instance, wind and solar energy.

2.9.1 Solar energy availability

The solar energy that is available is estimated to be 120 000 terawatts daily, and this implies that it is practically unlimited (Davis and MacKay, 2013). Only a small portion of Africa receives solar radiation less than 2 kWh.m⁻².day⁻¹ (Davis and MacKay, 2013). The solar energy that is received by most countries is between 4.5 and 5 kWh.m⁻².day⁻¹ (Heimiller, 2005). Thus, this energy could be used in agriculture to reduce electricity usage. More opportunities exist in Africa for the use of renewable energy, because the continent has limited access to electricity (Szabo *et al.*, 2011). Janjai *et al.* (2008) used solar dryers, with roof integrated solar collectors, using polycarbonate corrugated sheets. Rosella flower and chilli were dried from a 90-18% (wet basis) moisture content in three days, with a maximum drying temperature of 60°C, corresponding to a relative humidity of 10%.

2.9.2 Wind energy availability in Africa

South Africa, as well as other African countries, have a great potential for producing usable energy from the wind (Mentis, 2013). With regard to wind resources systems, Africa has an advantage (Mentis *et al.*, 2015) (Figure 2.3). In principle, the higher the wind speed, the higher the potential to generate usable energy.

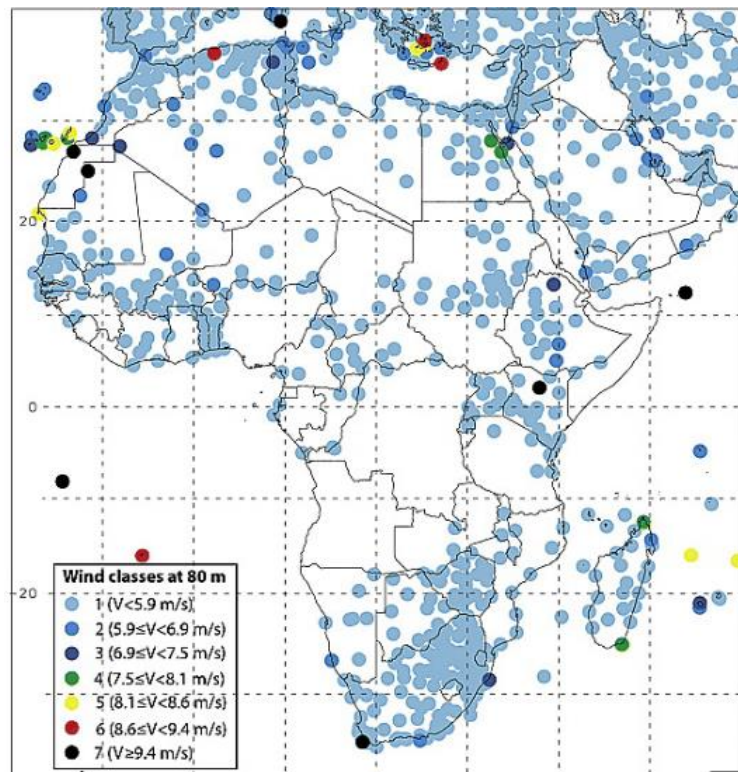

Figure 2.3 Wind speed map in Africa (Archer and Jacobson, 2005)

2.10 Components of a Seed Storage Room

The envisaged seed storage room will use solar energy and the power of a chimney to impact on the environment of the seeds. The components of the storage are reviewed in this section.

2.10.1 Chimney outlet configurations

Swiegers (2015) evaluated the effectiveness of elevating the volumetric flow rate of different outlet air configurations of the solar chimney for the Passive Downdraft Evaporative Cooling (PDEC) system, under different wind velocities, in a cold and hot solar chimney. The effectiveness of the outlet configuration is defined by its capability to pull the air out of the solar chimney. The chimney is important in improving the suction of the chimney. It transpired that a Whirlybird configuration gave good results for windy and still conditions and for both hot and cold solar chimneys (Swiegers, 2015). Therefore, Whirlybird has the great potential of improving the ventilation in the storage room.

2.10.2 Roof of a seed storage room

The roof should be modified, so that it can harness the most of the solar radiation. It must allow ambient air to enter, heated and proceed to the seeds inside the seed storage room. In this case, a suitable material for collecting solar radiation on the roof is required, and a suitable gap space is required for the inflow of ambient air into the structure. Janjai and Tung (2005) evaluated the performance of a solar dryer, using hot air from roof-integrated solar collectors for drying herbs and spices.

The collectors of the solar dryer were made of a black insulator, an iron frame and a transparent corrugated fiberglass cover, with a transmittance of 0.6 (Figure 2.4). A back insulator was made up of glass wool, which was inserted between two galvanised iron sheets. The upper surface of a back insulator was painted black. It was concluded that a solar air heater performed satisfactorily, both as a roof and as a solar collector for a farmhouse. In addition, the daily average efficiency achieved was 35%. However, Moumami *et al.* (2013) recommended a polycarbonate sheeting material for solar collectors, since it transmits almost 90% of the shortwave radiation. It is light in weight and flexible, and it does not break during hail events.

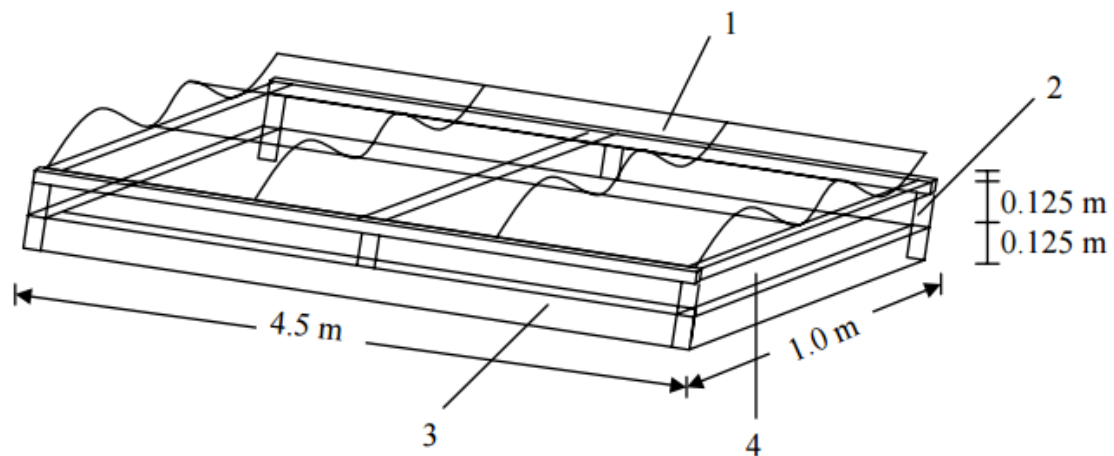

Figure 2.4 Schematic diagram of the solar collector: (1) corrugated fiberglass cover, (Weather2) iron frame, (3) back insulator, (4) air channel (the height between the absorber and the solar collector) (Janjai and Tung, 2005).

2.10.3 Air channel height

The air channel height is an important parameter that allows the air to flow into a solar collector. Román *et al.* (2009) evaluated the performance of a roof-integrated solar collector for preheating air at a drying facility, by changing the air channel height. They found that the

optimal air channel height was 10 cm. Sreekumar (2010) also used an air channel height of 10 cm in a roof integrated solar air heater and the maximum air temperature recorded was 76.6°C in the solar collector. Therefore, for this reason the solar collector will be used in this research.

2.10.4 Seed storage containers

Mettananda *et al.* (2001) studied the effect of the packing material, storage environment and seed moisture on the storability of maize. The study contained four environments (Table 2.1) and three types of packing materials, namely, woven polypropylene bag, and clear and white polythene bags. The maize moisture contents of 8 and 12% were used. The seeds stored in polythene bags performed better than the seeds stored in woven polypropylene bags, for both seed moisture contents (8 and 12%). Seed quality was maintained over a period of 15 months. The seed container also plays an important part in preventing insects from reaching the seeds. Adetumbi (2014) reported that hessian seed bags allow seed moisture to change in response to ambient conditions outside the bags, because the bags are not airtight. Thus, reducing seed moisture content during storage is possible with hessian bags.

Table 2.1 Mean temperatures and relative humidity during the period of the study (after Mettananda *et al.*, 2001)

Location	Temperature (°C)	Relative Humidity (%)
Peradeniya	29.5-20.6	82.3-74.0
Kundasale	29.8-20.4	79.6-67.6
Rahangala	23.8-15.3	77.8-76.3
Cold room	18-20	55-60

2.10.5 Packing seed bags for efficient flow of air in between them

According to the International Rice Research Institute (2016), seeds are usually packed in 40-80 kg jute or plastic bags and the following guidelines state how seed bags should be stacked:

- (a) Each stack should be 4 m high, except for plastic bags, which should be 3 m, since they are slippery.
- (b) The space between the roof and the highest point of the stack should be at least 1.5 m.
- (c) The space between each stack should be 1 m.

- (d) Bags should be loaded on pallets, or on an aboveground structure to decrease the likelihood of bags absorbing moisture from the floor.

2.11 Discussion

Literature shows that the storage micro-environment in a seed storage room is vital for the maintenance of seed quality. Plant breeders, farmers and seed companies require seeds of high quality. However, maintaining seed quality during storage remains a challenge in most rural areas of sub-Saharan Africa (Govender *et al.*, 2008; Kiva, 2012; Chattha and Lee, 2014). This is due to poor management of storage micro-environments during seed storage. Seeds of low quality imply a loss for the producer and are devastating for a breeding programme.

Condensation in a seed storage room can create favourable conditions for pests, mould, fungi, and other micro-organisms to grow and multiply (McDonald and Copeland, 2012; Bankole *et al.*, 2013; Chattha and Lee, 2014; Chiewchan *et al.*, 2015; Senthilkumar *et al.*, 2016). The cause of condensation in a structure is attributable to a poor ventilation system (Kovac and Vojtus, 2015). Condensation is avoided by ensuring that the seed storage room is well-ventilated.

Literature reveals that there are natural and mechanical ventilation systems. Natural ventilation occurs because of the air temperature difference, or air pressure difference, which facilitates the airflow in the structure (Swiegers, 2015). The natural ventilation intensity cannot be controlled, as it is a natural process. Mechanical ventilation, on the other hand, can be controlled, since it uses fans that ventilate air at a known volume (Carpenter, 2013; Said and Pradhan, 2014; Zhibin *et al.*, 2014). The natural movement of air inside a structure is facilitated by chimneys and by the location of air inlets and outlets for efficient airflow. A hybrid ventilation system exists, which combines both mechanical and natural ventilation and creates a healthy and highly-efficient ventilation system for the structure (Gao *et al.*, 2012; 2014; Gao *et al.*, 2014; Rong *et al.*, 2015; Tanaka *et al.*, 2015; Turner and Awbi, 2015).

Seeds require a seed bag that is made of a material that allows the gaseous exchange to manipulate the moisture content during storage and which is permeable. Thus, the quantity of gases in the atmosphere influences the physiological activities of the seeds. Modifying the atmosphere may, therefore, help to improve the seed quality during storage. According to the literature, hessian material is permeable and is suitable in cases where gaseous interaction between the seeds and the environment is required (Adetumbi, 2014).

Ventilation plays an important role in improving the storage micro-environment conditions (National Institute of Building Science, 2016). Lowering the relative humidity during storage has been reported to create a suitable micro-environment for seeds (Joao and Lovato, 1999; Mohammadi *et al.*, 2012). Lowering the relative humidity of the drying air is the process encountered in solar dryers, which use roof integrated solar collectors to heat air in order to dry the agricultural produce. Fans are used to draw air from the solar collector roof to a control chamber (Janjai *et al.*, 2008; Sreekumar, 2010; Buker and Riffat, 2015). Literature shows that solar dryers that use roof-integrated solar collectors are effective in decreasing the relative humidity. This technology may be applied in seed storage facilities, in order to modify the micro-environment, using solar-heated air.

2.12 Conclusions

The lack of proper storage facilities is a challenge in most sub-Saharan African countries. This is attributed to the poor conditions that currently exist in the storage facilities. There were different structural defects of the seed storage facilities in Nigeria. Structural defect indicated poor storage condition for seeds. It was also reported that condensation is one of the causes of the poor conditions in storage facilities and that leads to the rapid development of storage fungi in the structure. However, good ventilation in the structure prevents condensation. Generating a solution that will help improve the storage conditions in sub-Saharan Africa depends on the type of energy available with which to operate the storage system. The majority of Africans do not have access to grid electricity. Using renewable energy in the storage facility is a cheaper and feasible option for African people. The utilisation of solar energy has been successful in roof integrated solar dryers, solar chimney power plants and in other areas. The wind is also an important component in natural ventilation as it creates a pressure difference between the inlets and outlets of the structure, which improves the ventilation in the structure. Improving ventilation is of importance in the structure, to ensure that the seed quality is maintained. Reducing the relative humidity during storage preserves seed viability. Therefore, developing a naturally-ventilated seed storage room using solar-heated air to reduce the relative humidity and increase the air temperature in the storage facility environment, in order to create an optimum environment for seeds, may be a solution for this problem.

2.13 References

- Abbas, K, Saleh, AM, Lasekan, O and Abbas, HA. 2010. Significance and application of psychrometric chart in food processing: A review. *Journal of Food, Agriculture and Environment* 8(3):274-278.
- Adejumo, BA and Raji, AO. 2007. Technical appraisal of grain storage systems in the Nigerian Sudan savanna. *The CIGR Ejournal* 11(2007):1-11.
- Adetumbi, JA. 2014. Effect of storage environment and materials on moisture content and viability of maize (zeamays) seeds in storage. *Applied Tropical Agriculture* 1(14):89-94.
- Ali, MR, Rahman, MM and Ahammad, KU. 2014. Effect of relative humidity, initial seed moisture content and storage container on soybean (glycine max l. Meril.) seed quality. *Bangladesh Agricultural Research Institute* 39(3):461-469.
- Arce, J, Jimenez, MJ, Guzman, JD, Herus, MR, Alvarez, G and Xaman, J. 2009. Experimental study for natural ventilation on a solar chimney. *Renewable Energy* 34(2009):2928-2934.
- Archer, CL and Jacobson, MZ. 2005. Evaluation of global wind power. *Journal of Geophysical Research* 120(12):1-20.
- Balešević-Tubić, S, Tatić, M, Đorđević, V, Nikolić, Z and Đukić, V. 2010. Seed viability of oil crops depending on storage conditions. *Helia* 33(52):153-160.
- Bankole, YO, Taninola, OA and Adesina, BS. 2013. Evaluation of crop storage structures utilization in the Lagos state, Nigeria. *Journal of Educational and Social Research* 3(8):33-41.
- Bhardwaj, R, Sood, M and Thakur, U. 2014. Effect of storage temperature and period on seed germination of Rheum australe D Don: an endangered medicinal herb of high altitude Himalaya. *International Journal of Farm Sciences* 4(2):139-147.
- Bilgen, E and Rheault, J. 2005. Solar chimney power plants for high latitudes. *Solar Energy* 79(5):449-458.

- Brew-Hammond, A. 2010. Energy access in Africa: Challenges ahead. *Energy Policy* 38(5):2291-2301.
- Brooker, DB, Bakker-Arkema, FW and Hall, CW. 1992. *Drying and Storage of Grains and Oilseeds*. Van Nostrand Reinhold, New York, USA.
- Buker, MS and Riffat, SB. 2015. Building integrated solar thermal collectors – a review. *Renewable and Sustainable Energy Reviews* 51(2015):327-346.
- Cao, G, Awbi, H, Yao, R, Fan, Y, Sirén, K, Kosonen, R and Zhang, JJ. 2014. A review of the performance of different ventilation and airflow distribution systems in buildings. *Building and Environment* 73(2014):171-186.
- Carefully to Carry Committee. 2016. Moisture migration and surface ventilation. [Internet]. Carefully to Carry Committee, London, UK. Available from: <http://www.ukpandi.com/contact/offices-worldwide/london/>. [Accessed: 20 July 2016].
- Carpenter, G. 2013. Ventilation of buildings for intensively housed livestock. *Heat Loss from Animals and Man* 1(2013):389-403.
- Chattha, S and Lee, T. 2014. Storage methods and problems of wheat grain at Sindh, Pakistan. *Intl. J. Biosci* 5(7):260-274.
- Chattha, SH and TeangShui, L. 2014. Storage methods and problems of wheat grain at Sindh, Pakistan. *International Journal of Biosciences (IJB)* 5(7):260-274.
- Chen, Q, Yang, K, Wang, M, Pan, N and Guo, Z-Y. 2010. A new approach to analysis and optimization of evaporative cooling system I: Theory. *Energy* 35(6):2448-2454.
- Chiewchan, N, Mujumdar, AS and Devahastin, S. 2015. Application of drying technology to control aflatoxins in foods and feeds: a review. *Drying Technology* 33(14):1700-1707.
- Conklin, JR and Sellmer, JC. 2009. Germination and seed viability of norway maple cultivars, hybrids, and species. *HortTechnology* 19(1):120-126.
- Davis, J and MacKay, F. 2013. Solar Energy in the Context of Energy Use, Energy Transportation, and Energy Storage. [Internet]. University of Cambridge, Cambridge,

UK. Available from:
<http://www.inference.eng.cam.ac.uk/sustainable/book/tex/RSsolar.pdf>. [Accessed: 17 April 2016].

De Alencar, E, Faroni, L, de Lacerda Filho, A, Ferreira, L and Meneghitti, M. 2006. Influence of different storage conditions on soybean grain quality. *Stored Product Protection* 10(2006):78-86.

Deepika, V and Ashok, Y. 2014. Effect of seed storage on seed viability, germinability and morphological characteristics of karonda (*Carissa carandas*) seedlings. *Asian J. of Adv. Basic Sci* 2(3):1-6.

Dornbos, DL. 1995. Seed Vigour. In: ed. Basra, AS, *Seed Quality: Basic Mechanisms and Agricultural Implications*, Ch. 2, 45-80. The Haworth Press, Inc., New York, USA.

Earle, RL. 2004. *Unit Operations in Food Processing*. The New Zealand Institute of Food Science and Technology Inc., Palmerston, New Zealand.

Elias, S, Garay, A, Young, B and Chastain, T. 2016. Maintaining Grass Seed Viability in Storage. [Internet]. Oregon State University, Oregon, USA. Available from: <http://seedlab.oregonstate.edu/maintaining-grass-seed-viability-storage>. [Accessed: 01 May 2016].

FAO. 2016. Seed Storage. [Internet]. Food and Agriculture Organisation, Rome, Italy. Available from: <http://www.fao.org/docrep/006/ad232e/ad232e07.htm>. [Accessed: 03 April 2016].

Fudholi, A, Sopian, K, Ruslan, MH, Alghoul, MA and Sulaiman, MY. 2010. Review of solar dryers for agricultural and marine products. *Renewable and Sustainable Energy Reviews* 14(1):1-30.

Gao, J, Wargocki, P and Wang, Y. 2014. Ventilation system type, classroom environmental quality and pupils' perceptions and symptoms. *Building and Environment* 75(2014):46-57.

- Gao, R, Li, A, Hao, X, Lei, W, Zhao, Y and Deng, B. 2012. Fire-induced smoke control via hybrid ventilation in a huge transit terminal subway station. *Energy and Buildings* 45(1):280-289.
- Gawrysiak-Witulska, M, Rudzińska, M, Wawrzyniak, J and Siger, A. 2012. The effect of temperature and moisture content of stored rapeseed on the phytosterol degradation rate. *Journal of the American Oil Chemists' Society* 89(9):1673-1679.
- Govender, V, Aveling, TAS and Kritzing, Q. 2008. The effect of traditional storage methods on germination and vigour of maize (*Zea mays* L.) from northern KwaZulu-Natal and southern Mozambique. *South African Journal of Botany* 74(2):190-196.
- Grubinger, V and Sanford, S. 2015. Ventilation and Cooling Systems for Animal Housing. [Internet]. Cooperative Extension System, San Antonio, USA. Available from: http://articles.extension.org/pages/32633/ventilation-and-cooling-systems-for-animal-housing#Mechanical_Ventilation. [Accessed: 17 April 2016].
- Haaf, W, Friedrich, K, Mayr, G and Schlaich, J. 1983. Solar chimneys, part I: principle and construction of the pilot plant in Manzanares. *International Journal of Solar Energy* 2(1983):3-20.
- Hasan, A. 2010. Indirect evaporative cooling of air to a sub-wet bulb temperature. *Applied Thermal Engineering* 30(16):2460-2468.
- Hasibuan, R, Trisakti, B and Sundari, R. 2013. Simple integrated solar drying-molecular sieve system for the beneficiation of rosella (*Hibiscus sabdariffa*) plantation. *International Journal of Agricultural Policy and Research* 1(9):227-235.
- Heimiller, D. 2005. Africa Annual Direct Normal Solar Radiation. [Internet]. Economic Community of West African States Accra, Ghana. Available from: <http://en.openei.org/wiki/File:NREL-africa-dir.pdf>. [Accessed: 18 April 2016].
- Holmer, R, Linwattana, G, Nath, P and Keatinge, JDH. 2012. *High Value Vegetables in Southeast Asia: Production, Supply and Demand*. Report No. 15. Thailand Department of Agriculture, Bangkok, Thailand.

- Huang, BJ, Chang, JM, Petrenko, VA and Zhuk, KB. 1998. A solar ejector cooling system using refrigerant r141b. *Solar Energy* 64(4):223-226.
- Hughes, BR, Calautit, JK and Ghani, SA. 2012. The development of commercial wind towers for natural ventilation: A review. *Applied Energy* 92(1):606-627.
- International Rice Research Institute. 2013. Seed Quality [Internet]. International Rice Research Institute, Los Baños, USA. Available from: <http://knowledgebank.irri.org/images/docs/training-manual-seed-quality.pdf>. [Accessed: 04 June 2016].
- International Rice Research Institute. 2016. Storage Systems. [Internet]. International Rice Research Institute, Los Baños, USA. Available from: <http://www.knowledgebank.irri.org/step-by-step-production/postharvest/storage/grain-storage-systems>. [Accessed: 26 April 2016].
- ISTA Vigour Test Committee 1995. Understanding Seed Vigour. [Internet]. International Seed Testing Association, Zurich, CH-Switzerland Available from: <https://www.seedtest.org/upload/prj/product/UnderstandingSeedVigourPamphlet.pdf>. [Accessed: 05 April 2016].
- Janjai, S and Tung, P. 2005. Performance of a solar dryer using hot air from roof-integrated solar collectors for drying herbs and spices. *Renewable Energy* 30(14):2085-2095.
- Janjai, S, Srisittipokakun, N and Bala, BK. 2008. Experimental and modelling performances of a roof-integrated solar drying system for drying herbs and spices. *Energy* 33(2008):91-103.
- Joao, AE and Lovato, A. 1999. Effect of seed storage temperature and relative humidity on maize (*Zea mays* L.) seed viability and vigour. *Seed Science and Technology* 27(1):101-114.
- Kandil, AA, Sharief, AE and Sheteiwy, MS. 2013. Effect of seed storage periods, conditions and materials on germination of some soybean seed cultivars. *American Journal of Experimental Agriculture* 3(4):10-20.

- Kenneth, M and Elovitz, PE. 1999. Understanding what humidity does and why. *ASHRAE Journal* 1(1999):75-81.
- Khanal, R and Lei, C. 2011. Solar chimney-a passive strategy for natural ventilation. *Energy and Buildings* 43(8):1811-1819.
- Kiaya, V. 2014. Post harvest losses and strategies to reduce them. *Technical Paper on Postharvest Losses, Action Contre la Faim (ACF)* 1(2014):1-25.
- Kiva. 2012. Kiva Innovations: Storage Facilities for Smallholder Farmers in East Africa. [Internet]. Kiva, Nairobi, Kenya. Available from: <https://www.kiva.org/blog/kiva/2012/09/25/kiva-innovations-storage-facilities-for.html>. [Accessed: 02 May 2017].
- Kovac, M and Vojtus, J. 2015. Analysis of air velocity, moisture and thermal regime in an air gap of a double-shell roof. *Energy Procedia* 78(1):759-764.
- Liu, J, Aizawa, H and Yoshino, H. 2004. CFD prediction of surface condensation on walls and its experimental validation. *Building and Environment* 39(8):905-911.
- Mbofung, GCY, Goggi, AS, Leandro, LFS and Mullen, RE. 2013. Effects of storage temperature and relative humidity on viability and vigor of treated soybean seeds. *Crop Science Society of America* 53(2013):1086-1095.
- McDonald, M and Copeland, LO. 2012. *Seed Production: Principles and Practices*. Springer Science and Business Media, Berlin, Germany.
- McDonald, MB. 2007. Seed moisture and the equilibrium seed moisture content curve. *Seed Technology* 29(2007):7-18.
- Mentis, D, Hermann, S, Howells, M, Welsch, M and Siyal, SH. 2015. Assessing the technical wind energy potential in Africa a GIS-based approach. *Renewable Energy* 83(2015):110-125.
- Mentis, D. 2013. *Wind Energy Assessment in Africa A GIS-based Approach*. Report No. 13. Vetenskap Och Konst KTH, Stockholm, Sweden.

- Mettananda, K, Weerasena, S and Liyanage, Y. 2001. Effect of storage environment, packing material and seed moisture content on storability of maize (*Zea mays* L.) seeds. *Annals of the Sri Lanka Department of Agriculture* 3(2001):131-142.
- Mohammad, AF and Majid, B. 2013. Analytical model of mist condensation by natural convection over inclined flat surfaces. *Heat Transfer* 06(2013):1-7.
- Mohammadi, H, Soltani, A, Sadeghipour, HR and Zeinali, E. 2012. Effects of seed aging on subsequent seed reserve utilization and seedling growth in soybean. *International Journal of Plant Production* 5(1):65-70.
- Moumimi, N, Chabane, F, Benramache, S and Brima, A. 2013. Thermal efficiency analysis of a single-flow solar air heater with different mass flow rates in a smooth plate. *Frontiers in Heat and Mass Transfer (FHMT)* 4(1):1-6.
- Nagel, M and Börner, A. 2010. The longevity of crop seeds stored under ambient conditions. *Seed Science Research* 20(01):1-12.
- National Institute of Building Science. 2016. Natural Ventilation. [Internet]. National Institute of Building Science, Washington DC, USA. Available from: <https://www.wbdg.org/resources/naturalventilation.php>. [Accessed: 29 April 2016].
- Nguyen, VM, Riffat, SB and Doherty, PS. 2001. Development of a solar-powered passive ejector cooling system. *Applied Thermal Engineering* 21(2001):157-168.
- Niaz, I, Dawar, S and Sitara, U. 2011. Effect of different moisture and storage temperature on seed borne mycoflora of maize. *Pakistan Journal of Botany* 43(5):2639-2643.
- Oko, C and Diemuodeke, E. 2010. Analysis of air-conditioning and drying processes using spreadsheet add-in for psychrometric data. *Journal of Engineering Science and Technology* 3(1):7-13.
- Osueke, CO. 2013. Design modelling of a fluidized bed for grain drying. *International Journal of Engineering Research and Development* 7(9):10-15.
- Perveen, S, Nigar, S, Khalil, SK and Zubair, M. 2010. Vigor tests used to rank seed lot quality and predict field emergence in wheat. *Pak. J. Bot* 42(5):3147-3155.

- Pretorius, JP and Kröger, DG. 2006. Critical evaluation of solar chimney power plant performance. *Solar Energy* 80(5):535-544.
- Pringle, R and Robinson, K. 1996. Storage of seed potatoes in pallet boxes: the role of tuber surface moisture on the population of *Erwinia* bacteria. *Potato Research* 39(2):205-222.
- Qi, XW, Li, WK, Li, W and Li, H.2011. Study on the vigour testing of soybean seed based on near infrared spectroscopy technology. *Applied Mechanics and Materials*, 458-462. Trans Tech Publ.
- Ranjbaran, M and Emadi, B. 2015. A mathematical model of commodity wet-bulb temperature (CWBT) for grain storage applications. *Biosystems Engineering* 139(2015):128-135.
- Rathore, NS and Panwar, NL. 2010. Experimental studies on hemi cylindrical walk-in type solar tunnel dryer for grape drying. *Applied Energy* 87(8):2764-2767.
- Renata, OA and Julio, M. 2014. Vigor evaluation of stored cotton seeds, including the seed vigor imaging system (SVIS®). *Journal of Seed Science* 36(2):222-230.
- Román, F, Nagle, M, Leis, H, Janjai, S, Mahayothee, B, Haewsungcharoen, M and Müller, J. 2009. Potential of roof-integrated solar collectors for preheating air at drying facilities in Northern Thailand. *Renewable Energy* 34(7):1661-1667.
- Rong, L, Liu, D, Pedersen, E and Zhang, G. 2015. The effect of wind speed and direction and surrounding maize on hybrid ventilation in a dairy cow building in Denmark. *Energy and Buildings* 86(2015):25-34.
- Rubenstein, I, Philips, RL, Green, CE and Gengenbach, BG. 1979. *The Plant Seed: Development, Preservation, and Germination*. Academic Press, Inc., New York, USA.
- Said, PP and Pradhan, C. 2014. Food grain storage practices-a review. *Journal of Grain Processing and Storage* 1(1):01-05.
- Sarbu, I and Sebarchievici, C. 2013. Review of solar refrigeration and cooling systems. *Energy and Buildings* 67(2013):286-297.

- Sawant, AA, Patil, SC, Kalse, SB and Thakor, NJ. 2012. Effect of temperature, relative humidity and moisture content on germination percentage of wheat stored in different storage structures *CIGR Journal* 14(2012):1-14.
- Senthilkumar, T, Jayas, DS, White, NDG, Fields, PG and Gräfenhan, T. 2016. Detection of fungal infection and Ochratoxin: a contamination in stored wheat using near-infrared hyperspectral imaging. *Journal of Stored Products Research* 65(2016):30-39.
- Shallcross, D. 2012. *Handbook of Psychrometric Charts: Humidity diagrams for engineers*. Springer Science and Business Media, New York, USA.
- Song, D, Kim, T and Song, S. 2008. Performance evaluation of a radiant floor cooling system integrated with dehumidified ventilation. *Applied Thermal Engineering* 28(2008):1299-1311.
- Sreekumar, A. 2010. Techno-economic analysis of a roof-integrated solar air heating system for drying fruit and vegetables. *Energy Conversion and Management* 51(11):2230-2238.
- Swiegers, JJ. 2015. *Inlet and Outlet Shape Design of Natural Circulation Building Ventilation Systems*. Report No. 045. Stellenbosch University, Stellenbosch, South Africa.
- Szabo, S, Bódis, K, Huld, T and Moner-Girona, M. 2011. Energy solutions in rural Africa: mapping electrification costs of distributed solar and diesel generation versus grid extension. *Environmental Research Letters* 6(3):1-9.
- Tanaka, F, Majima, S, Kato, M and Kawabata, N. 2015. Performance validation of a hybrid ventilation strategy comprising longitudinal and point ventilation by a fire experiment using a model-scale tunnel. *Fire Safety Journal* 71(2015):287-298.
- Turner, WJ and Awbi, HB. 2015. Experimental investigation into the thermal performance of a residential hybrid ventilation system. *Applied Thermal Engineering* 77(2015):142-152.
- Ventura, L, Donà, M, Macovei, A, Carbonera, D, Buttafava, A, Mondoni, A, Rossi, G and Balestrazzi, A. 2012. Understanding the molecular pathways associated with seed vigor. *Plant Physiology and Biochemistry* 60(2012):196-206.

- Waaf, W. 1984. Solar chimneys, part II: preliminary test results from the Manzanares pilot plant. *International Journal of Solar Energy* 2(1984):141-161.
- Weather2. 2016. Pietermaritzburg Climate History. [Internet]. Weather2, Glasgow, Scotland. Available from: <http://www.myweather2.com/City-Town/South-Africa/Pietermaritzburg/climate-profile.aspx>. [Accessed: 10 May 2016].
- Zhibin, H, Linxiang, J, Xueliang, Z, Xuduo, C and Depot, JG. 2014. Study on the different power fan ventilation experiment in the silo. *Grain Storage* 1(2014):1-8.
- Zhou, X, Wang, F and Ochieng, RM. 2010. A review of solar chimney power technology. *Renewable and Sustainable Energy Reviews* 14(8):2315-2338.

3. DEVELOPING A SEED STORAGE ROOM THROUGH THE ALTERATION OF DIFFERENT CHIMNEY SIZES

Abstract

In this study, an ordinary 22 m³ residential room was converted to a seed storage facility. This was done by retrofitting a solar collector on the roof, which is made of corrugated polycarbonate sheets (solar collector sheeting) and a chimney. Different chimney sizes were investigated to find the best size of the chimney to be used for ventilation in a storage facility. The chimney sizes used had a diameter and height of 200 mm x 3.6 m, 200 mm x 4.8 m, 300 mm x 3.6 m and 300 mm x 4.8 m. The parameters that were measured were the air velocity in the chimney duct, as well as the air temperature and relative humidity at the inlet, centre and outlet of the storage facility. The diameter of the chimney had an influence on the ventilation rate achieved in the storage facility. Significant differences were found between the different chimney diameters and heights ($P \leq 0.05$). The 300 mm x 3.6 m and 300 x 4.8 m chimneys achieved ventilation rates of 9.2 ACH and 17.4 ACH, respectively, which were higher than the minimum recommended ventilation rate required for storing seeds. The 300 mm diameter chimneys were able to extract hot air from the roof solar collector; however, the 200 mm diameter failed. The modified naturally-ventilated seed storage room was able to reduce the relative humidity from 69.7% to a safe relative humidity of 37.9%, whereas the temperature increased from 23.3°C to 35°C in the 300 mm x 4.8 m chimney. Therefore, the ventilation rate, temperature and relative humidity improved by using different chimney sizes, and in this way, a naturally-ventilated seed storage was developed. Furthermore, increasing the diameter of the chimney had a greater effect on the ventilation rate than increasing the height. An optimum size was not reached, since for the highest chimney size used in this study the ventilation rate was still increasing. Hence, both the diameter and height of the chimney still need to be optimised. A chimney size of 300 mm x 4.8 m performed better than the other sizes that were investigated.

3.1 Introduction

Historically, chimneys are predominantly used to ventilate buildings and to remove exhaust gases from the fireplace. Solar chimneys have been used to generate electricity and to ventilate buildings. These chimneys use the principle of thermal buoyancy, so that the part of the chimney is made of a solar collector, consisting of glazing and an absorber material, for the optimum harvesting of solar radiation. The solar collector heats the air inside the chimney,

which causes the temperature difference between the temperature of the air inside the chimney and the air temperature outside the chimney. Passive stack ventilation works well when the indoor temperature is higher than the outdoor temperature. However, the solar chimney will induce ventilation effectively, even when the outdoor temperature is equal to, or higher than, the indoor temperature (Charvat *et al.*, 2004). Another way solar chimneys are made is by merely painting the body surface of the chimney black. The temperature difference causes the hot air to rise, which leads to the upward movement of air, and in this way, ventilation in the building is achieved (Wei *et al.*, 2011). There are horizontal and vertical solar chimneys; however, (Kumar *et al.*, 2017) reported that vertical chimneys increase the ventilation rate up to 22 times, compared to horizontal chimneys. Huynh (2010) added that a solar chimney attains the maximum flow rate when it is in its vertical position. The effect of a solar chimney on ventilating a residential buildings was investigated by Mekkawi and Elgendy (2016). The study revealed that a solar chimney decreased the average room temperature and improved the average indoor velocity by 50%. The ventilation rate induced by a solar chimney, with a height of 4.57 m in a 510-m³ room was investigated by Lal *et al.* (2013). A ventilation rate in the range of 5.77 to 7.77 ACH was achieved. Solar chimneys are used to improve the indoor environment through natural ventilation (Siva Reddy *et al.*, 2012; Alzaed and Mohamed, 2014; Park and Battaglia, 2015; Nakielska and Pawłowski, 2017).

According to the study by Tan and Wong (2012), solar chimney system operated well in ventilating a three-story building. In addition, it was effective in hot and humid climates and even in cooler days. The study carried out by Khedari *et al.* (2000), where the solar chimney was used to reduce the internal heat gain in a 25-m³ room revealed that solar chimneys were good for circulating the air inside the structure. The achieved air change rate per hour was 8-15 ACH. Bassiouny and Koura (2008) showed that changing the solar chimney size has more effect on the airflow and air change rate than changing the inlet size in the ventilated structure. Increasing the inlet by three-folds resulted in an 11% increase in the air change rate, whereas increasing the outlet by the same factor resulted in a 25% increase in the air change rate. Alzaed and Mohamed (2014) studied the solar chimney and focused on the effect of inlet area, the chimney width and height and incident solar radiation on the ventilation rate that was induced in the building, using a prototype building. The chimney widths considered were in a range of 5-30 mm and 8-50 mm, for chimney heights, 200 mm and 400 mm, respectively. The optimum width was found to be 12 mm for a 200 mm height and 24 mm for a 400 mm height. Beyond this width, the ventilation rate decreased, and a further increase in the width resulted in a

backflow. Increasing the outlet (chimney area) was found to be more effective than increasing the inlets, with regards to ventilation rates achieved, and this is in agreement with the results obtained by Bassiouny and Koura (2008). Doubling the chimney height from 200 mm to 400 mm resulted in the doubling of the ventilation rate and it was therefore concluded that increasing the height is an effective way of improving the ventilation rate in a building. Ali (2010) also found that increasing the height of the solar chimney enhances its performance. It is not only the height of the solar chimney that influences the ventilation rate, but the cross-sectional area also affects the ventilation rate greatly (Mekkawi and Elgendy, 2016). Alzaed and Mohamed (2014) carried out a study on the performance of the solar chimney by changing the width from 5 cm to 10 cm and the results showed that better ventilation rates were achievable with a width of 5 cm. A width of 10 cm gave a low ventilation rate, since it was beyond the optimum width.

Li *et al.* (2004) investigated the following parameters of the solar chimney, namely, the height, width, cavity width, as well as the ratio of the outlet to inlet area, and lastly the outlet location of the solar chimney, using computational fluid dynamics (CFD), fluid flow and MITFLOW models. The length, width (B), height (H), the ratio of outlet area to inlet area A_r and the cavity width (B/H), had the following ranges, 0.5 – 5 m, 0.1 – 0.5 m, 2 – 5 m, 0.6 – 1 m, 0.05 – 0.25, respectively. It was found that there is an optimum cavity width and solar chimney width that correspond to the maximum ventilation rate, and when the height is increased, the ventilation rate increases. This is in agreement with the results obtained by Mathur *et al.* (2006), Bassiouny and Koura (2008), Ali (2010), Yan *et al.* (2011) and Mehani and Settou (2012). In addition, the results revealed that optimised ventilation rate is achieved when the inlet area is equal to outlet area. The chimney height and width have a significant impact on natural ventilation, according to Hassanein and Abdel-Fadeel (2012).

In most cases, solar chimneys are used to ventilate structures like residential buildings. This provides a platform for investigating the performance of the solar chimney in other areas, such as the naturally-ventilated seed storage facilities. The storage facility consists of the solar collector on the roof, for heating the incoming air into the storage room and to reduce the relative humidity. Therefore, the objective of this study is to develop a naturally-ventilated seed storage room by investigating the performance of different solar chimney sizes subjected to the same load of maize seeds. The study will focus on both the diameter (cross sectional area) and the height of the chimney as parameters for defining the size of the chimney. In addition, these parameters are crucial in the design of the solar chimney (Lal *et al.*, 2013; Ravanfar, 2013;

Jafari and Poshtiri, 2017). The performance will be evaluated by looking at the temperature and relative humidity profiles inside the storage facility and the ventilation rate that is achieved in response to the outdoor environmental conditions.

3.2 Materials and Methods

3.2.1 Experimental site and climatic data

The seed storage facility is located at the University of KwaZulu-Natal Ukulinga Research Farm, Pietermaritzburg (PMB), South Africa (30°24'S, 29°24'E). The Ukulinga site is shown in Figure 3.1. It is located at an altitude of 721 m and experiences a mean annual temperature of 18.4°C, with summers ranging from warm to hot and mild winters (Everson *et al.*, 2013). The average wind speed in PMB has been reported to be 0.8 m.s⁻¹ for the past two decades, and in recent years the maximum wind speed reached was 9.7 m.s⁻¹ (Weather2, 2016). East-southeast is the prevailing wind direction in PMB (Windfinder, 2016).

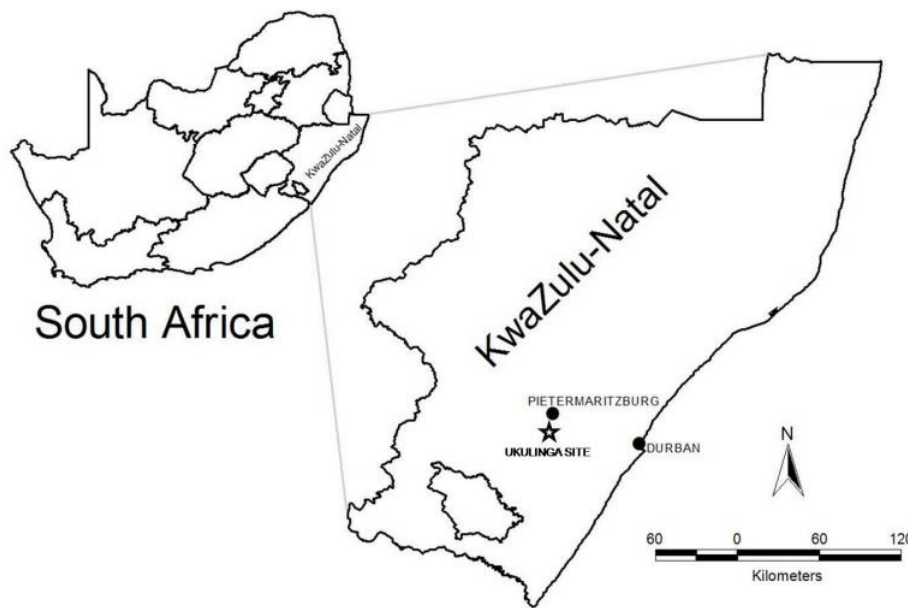

Figure 3.1 Research site

3.2.2 Seed storage facility description

The seed storage facility has a volume of 22 m³ (Figure 3.2) and it consists of a roof integrated solar collector for heating the air before it enters the storage room. The solar chimney used was made of Galvanized steel, which was painted black.

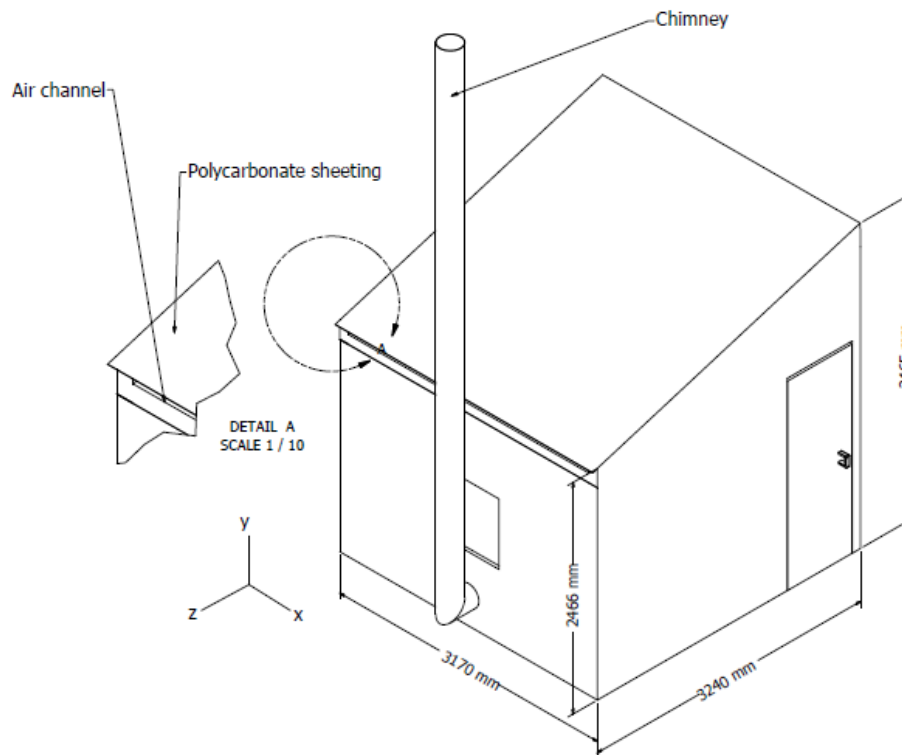

Figure 3.2 Storage facility

3.2.3 Solar collector

The solar collector consists of a clear corrugated polycarbonate sheets with a standard thickness of 1 mm, a width of 760 mm and a length of 3.5 m (Moumami *et al.*, 2013). The polycarbonate sheets are supported by a frame made of mild steel bars, with a cross-sectional area of 3 mm by 50 mm (Janjai and Tung, 2005). The corrugated iron sheets underneath the polycarbonate sheets were painted black for enhancing the absorption of radiation and a space of 10 cm was left between them, as an air channel.

3.2.4 Shelf for seed bags

Seed bags are made of a hessian material (Adetumbi, 2014) and stacked on pallets (International Rice Research Institute, 2016). Each seed sack will contain 10 kg of seeds, since the moisture content equilibrates quickly in the seed mass (Chattha *et al.*, 2012).

3.2.5 Experimental units

The following are the experimental treatments that were the combination of the chimney diameter and the height:

- (a) 200 mm x 3.6 m,
- (b) 200 mm x 4.8 m,

(c) 300 mm x 3.6 m,

(d) 300 mm x 4.8 m.

3.2.6 Data collection

The collected data were the temperature and relative humidity of the indoor and outdoor environment, the air velocity in the chimney duct and the solar radiation intensity. Data loggers (Onset HOBO Four Channel USB Temperature/Humidity/Light/External Input Data Logger with 12-bit resolution) are installed for measuring the temperature and relative humidity inside the storage facility. They were placed at the inlet, at the centre of the structure and at the outlet. The control room, which was without airflow, had only two data loggers installed at the centre of the structure and inside the seed bags. The loggers for temperature and relative humidity recorded data every minute, from 9:00 am until 17:00 pm, on sunny days. The velocity in the chimney duct was measured manually at least every 30 minutes with a Heavy Duty Hot Wire Thermo-Anemometer Airflow Meter. The experiment was run over a period of four days, where only sunny days were selected, that is, days with an average temperature of at least 30°C. Each day had a different chimney size combination. From each of the days selected, one hour, with the temperature range of 28-31°C was selected for data comparison.

3.3 Data Analysis

Analysis of variance, with a 5% level of significance on the data of air temperature, air relative humidity and air velocity in the chimney duct will be carried out, using Genstat18.0.

3.4 Results and Discussion

This section discusses the results obtained from this study, namely, the air temperature, the relative humidity and the velocity of the air in the chimney duct of the storage facility.

3.4.1 Velocity in the chimney duct

The velocity of the air recorded in the chimney duct was different, depending on the different chimney sizes. The velocity acquired for 200 mm and 300 mm were significantly different ($P \leq 0.05$) (see Figure 3.3). Velocity measured for a 200 mm diameter for both chimney heights had similar mean velocities, namely, 0.1 ± 0.09 and $0.094 \text{ km}\cdot\text{hr}^{-1} \pm 0.07$ for the 3.6 m and 4.8 m heights, respectively. Extremely low velocities in the solar chimney are the consequence of the reverse flow in the duct (Alzaed and Mohamed, 2014), which indicates that a chimney diameter of 200 mm is failing to create enough suction to circulate in the storage room. In short, this chimney size induces an insufficient draft to overcome system flow resistance, which is

due to chimney flow resistance coefficient being inversely proportional to the diameter; for instance, small diameters result in high resistance (Farshadmanesh *et al.*, 2014). Therefore, increasing the diameter of a chimney will increase the chimney draft. Furthermore, this can also be observed in Figure 3.10, where the temperatures at all the positions inside the storage room are similar, indicating a great possibility that the air might be stagnant, because air sinking naturally in the space, cools (Ansari *et al.*, 2017). A 300 mm chimney achieved $0.356 \pm 0.1 \text{ km}\cdot\text{hr}^{-1}$ and $0.675 \pm 0.14 \text{ km}\cdot\text{hr}^{-1}$, for 3.6 m and 4.8 m heights, respectively. The average air change per hour (ACH) achieved by a chimney with a diameter of 300 mm at heights of 3.6 m and 4.8 m, was 9.2 ACH and 17.4 ACH, respectively. The minimum ventilation rate recommended for stored maize seeds is $0.08 \text{ m}^3\cdot\text{min}^{-1}$ (Reed, 2009); however, the achieved ventilation rate was $6.4 \text{ m}^3\cdot\text{min}^{-1}$ and $3.4 \text{ m}^3\cdot\text{min}^{-1}$, for heights of 4.8 m and 3.6 m, respectively, with the diameter of 300 mm. Longer chimneys provide more ventilation than shorter chimneys, due to the large vertical distance from the chimney foot to the outlet of the chimney, which provides an excessive draft (Imran *et al.*, 2015).

An improvement in the ventilation rate was observed when the chimney diameter was increased from 200 mm to 300 mm. Similarly, when the height was increased from 3.6 m to 4.8 m, an increase in ventilation rate was also observed (see Figure 3.3). These findings agree with those of (Li *et al.*, 2004); Mathur *et al.*, 2006); Bassiouny and Koura, 2008; Ali, 2010; Yan *et al.*, 2011; Mehani and Settou, 2012). A huge change in the ventilation rate was observed when the chimney diameter was changed, compared to when the chimney height was changed. Changing the diameter from 200 mm to 300 mm, for the same height of 4.8 m, changed the ventilation rate from $0.89 \text{ m}^3\cdot\text{min}^{-1}$ to $6.4 \text{ m}^3\cdot\text{min}^{-1}$. Afonso and Oliveira (2000), Bassiouny and Koura (2008) and Tan and Wong (2013) reported that the cross-sectional area (diameter) in the design of the solar chimney has a stronger effect on the ventilation rate and airflow pattern than the chimney height. When the chimney cross-sectional area is increased beyond its optimum size, reverse flow begins to take place in the solar chimney and this results in a reduction in the ventilation rate (Bassiouny and Koura, 2008; Alzaed and Mohamed, 2014; Asadi *et al.*, 2016). From the current study, the optimum diameter was not reached, since 300 mm gave a higher ventilation rate than the 200 mm chimney. However, the chimney size that performed better than the rest in the current study was that with a 300 mm diameter and a height of 4.8 m.

Table 3.1 The results of the inlet, centre and outlet temperature, relative humidity and velocity as a result of different chimney sizes

	Inlet RH (%)	Centre RH (%)	Outlet RH (%)	Inlet Temp (°C)	Centre Temp (°C)	Outlet Temp (°C)	Velocity (m·s ⁻¹)
mean.200mm.3.6m	59.6±0.97	70.9±0.59	71.28±3.57	26.3±0.54	27.8±0.13	23.8±1.05	0.1±0.09
mean.200mm.4.8m	57.2±0.78	70.5±3.35	69.31±0.80	27.8±0.50	27.6±0.23	24.7±0.22	0.094±0.07
mean.300mm.3.6m	13.7±3.01	44.6±0.55	54.3±2.09	46.4±4.87	34.2±0.24	31.8±0.16	0.356±0.1
mean.300mm.4.6m	9.4±1.81	37.9±0.47	45.7±0.53	54.2±2.64	35.7±0.15	31.1±0.53	0.675±0.14
p.value diameter	<0.001	<0.001	<0.001	<0.001	<0.001	<0.001	<0.001
p.value height	<0.001	<0.001	<0.001	<0.001	<0.001	0.021	<0.001
p.value height.diameter	<0.001	<0.001	<0.001	<0.001	<0.001	0.01	<0.001

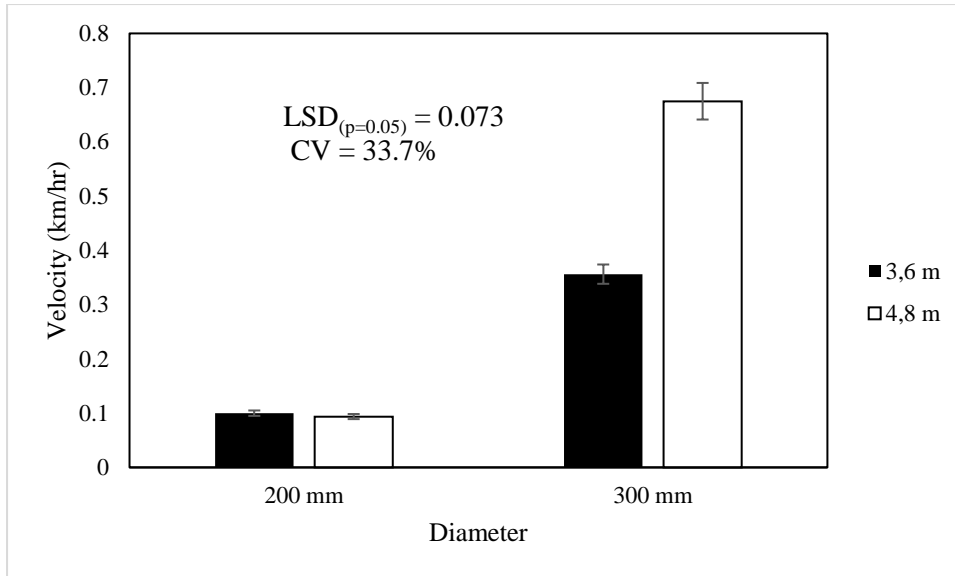

Figure 3.3 Air velocity in the chimney duct

3.4.2 Relative humidity at the inlet

The storage facility operates by heating the ambient air before it enters the indoor environment in the solar collector on the roof. The duty of the chimney is to drive the heated air from the roof solar collector, down to the indoor environment and out through its duct. The results revealed that a 300 mm diameter chimney induced a significantly lower ($P \leq 0.05$) relative humidity in the inlet than a 200 mm diameter chimney. A lower relative humidity was attainable with a chimney height of 4.8 m, compared to a chimney height of 3.6 m ($P \leq 0.05$). When the heights are combined with a diameter of 200 mm, the results show a high relative humidity, compared to when the heights are combined with 300 mm chimney (see Figure 3.4). The initial temperature and relative humidity in the storage room were 23.3°C and 69.7%. For a 200 mm diameter chimney, the relative humidity decreased by 10.1% and 12.5%, for 3.6 m and 4.8 m chimney heights, respectively. However, for a 300 mm diameter chimney, the relative humidity decreased drastically by 56% and 60.3%, relative to the initial relative humidity, for 3.6 m and 4.8 m chimney heights, respectively. When the temperature changes the relative humidity also changes and high temperatures resulting in a low relative humidity, and vice versa (Exell, 2017; Jindal and Gunasekaran, 2017). The reason why the relative humidity decreased drastically for the 300 mm diameter chimney for all heights (3.6 and 4.8 m), is because this size is capable of extracting hot air from the roof solar collector and driving it to the storage environment, which eventually changes the storage conditions. On the other

hand, the 200 mm had a slight reduction in relative humidity, this is because it is incapable of extracting hot air from the solar collector. This slight reduction in relative humidity was caused by the pressure that developed in the roof solar collector, due to thermal convection of hot air rising along the roof slope and the wind pressure pushing the heated air into the inlets. Therefore, hot air was reaching the inlets intermittently, resulting in a slight reduction in relative humidity, as opposed to the case of 300 mm diameter where hot air was extracted continuously, resulting in constantly high temperatures.

For the same diameter, a height of 4.8 m always gives lower relative humidity than a height of 3.6 m (see Figure 3.4). The results imply that a bigger diameter draws the air better from the solar collector than a smaller diameter. Moreover, the longer the chimney, the better the performance of the chimney, in driving hot air into the storage indoor environment from the solar collector. Air heated by the solar collector has a low relative humidity. From the previous studies, the focus has been on the solar chimneys with a rectangular cross-section, where the width of the solar chimney was varied to assess the effect of cross-sectional area (Yan *et al.*, 2011) . The effect of height was also investigated. The current study investigates the effect of changing the chimney diameter, which directly reflects the cross-sectional area of the solar chimney . Yan *et al.* (2011) and Guo *et al.* (2016) showed that the increasing chimney height and cross-section, as defined by the width, improves its performance. This agrees with the results obtained in the current study. A chimney with a height of 4.8 m and a diameter of 300 mm gave better results than the rest of the chimney sizes explored.

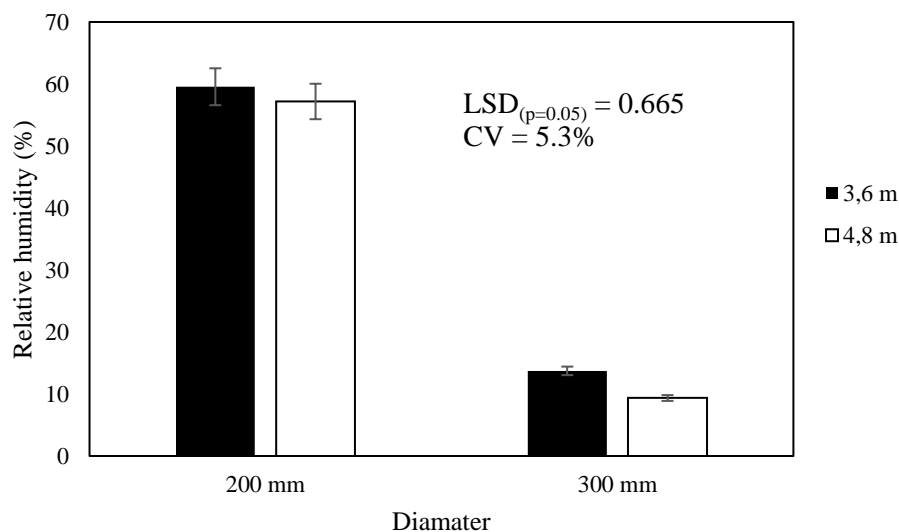

Figure 3.4 Inlet air relative humidity

3.4.3 Relative humidity at the centre

The relative humidity in the storage centre with 300 mm diameter chimney was found to be lower than that with a 200 mm chimney diameter ($P \leq 0.05$) (see Figure 3.5). A chimney height of 4.8 m had a lower relative humidity than a chimney height of 3.6 m ($P \leq 0.05$). There was a significant difference between the combination of the diameter and height of the solar chimney ($P \leq 0.05$). The average relative humidity obtained in the room centre is higher than the relative humidity obtained in the inlets, due to the cooling of air, as it is drawn from the roof solar collector down to the centre of the room. The results showed that a 200 mm chimney diameter is not capable of extracting hot air from the roof solar collector. Since there is no change in relative humidity in the centre, which is $70.9 \pm 0.59\%$ and $70.5 \pm 3.35\%$, for 3.6 m and 4.8 m chimney heights, respectively, and which is relative to the initial relative humidity (69.7%). Figure 3.5 shows that both a diameter of 300 mm, and a height of 4.8 m had a significantly lower ($P \leq 0.05$) relative humidity ($37.9 \pm 0.47\%$) than a height of 3.6 m ($44.6 \pm 0.55\%$). For a diameter of 300 mm, there was a larger decrease in relative humidity for both heights, relative to the initial relative humidity of 69.7%. To show that the 300 mm diameter chimney was working, the relative humidity was increased by 30.7% and 28.5%, for the 3.6 m and 4.8 m chimney heights, respectively. Increasing relative humidity implies that hot air is sinking in the storage space, from the inlets to the centre, which further implies circulation (Ming *et al.*, 2016). In the current study, the chimney size of 300 mm diameter and 4.8 m high gave better results, when compared to the other chimney size. Furthermore, there is a reduction in the relative humidity in the storage room.

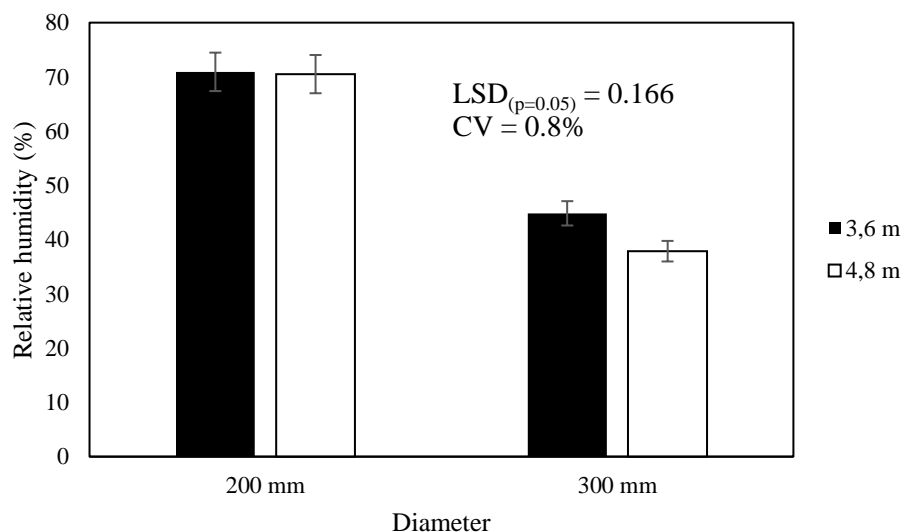

Figure 3.5 Air relative humidity at the centre of the storage

3.4.4 Relative humidity at the outlet

The results show that the relative humidity at the outlet ($71.3 \pm 3.57\%$ for 3.6 m) is similar to the relative humidity obtained at the centre of the storage room ($70.9 \pm 0.59\%$ for 3.6 m) for the same chimney diameter of 200 mm (see Figure 3.11). Similarly, for the height of 4.8 m, no change was observed. On the other hand, at a chimney diameter of 300 mm, a significant difference ($P \leq 0.05$) was observed between the relative humidity of air at the centre of the storage and the air at the outlet for both chimney heights. As the room space cools due to the downward movement of air, it retains a high relative humidity, which is the case with a chimney size of 300 mm. On the contrary, a chimney size of 200 mm shows no change in relative humidity, implying that there is no downward movement of the air. Relative humidity at the outlet for a chimney with a diameter of 200 mm is significantly higher ($P \leq 0.05$) than the relative humidity obtained for a chimney with a 300 mm diameter. For a 300 mm diameter chimney, lower relative humidity was achieved ($P \leq 0.05$) with 4.8 m high chimney ($45.7 \pm 0.53\%$), compared with a 3.6 m high chimney ($54.3 \pm 2.09\%$) (see Figure 3.6). Increasing the height and the diameter of the solar chimney improved its performance. A previous study by Ali (2010) and Guo *et al.* (2016) obtained similar results. A chimney with a diameter of 300 mm and a height of 4.8 m performed better.

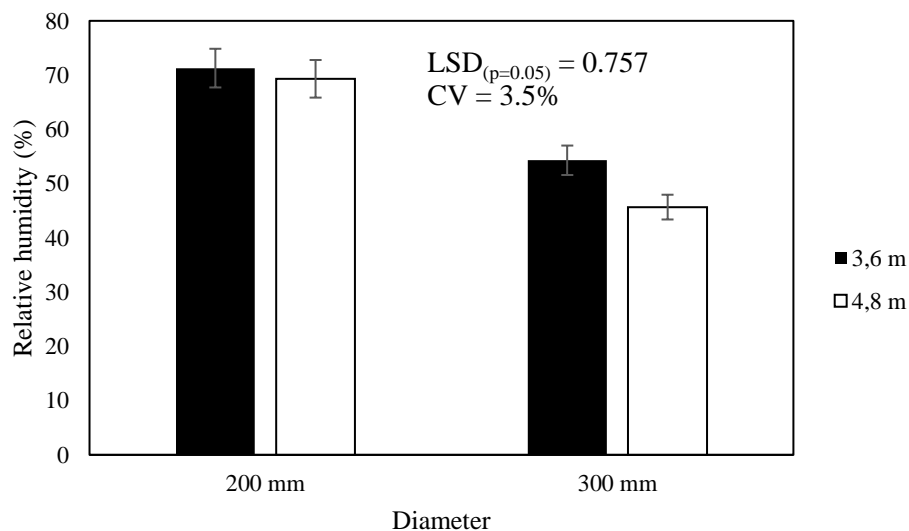

Figure 3.6 Outlet relative humidity

3.4.5 Temperature at the inlet

A chimney with a diameter of 300 mm obtained high temperatures at the inlet, namely, $46.4 \pm 4.87^\circ\text{C}$ and $54.2 \pm 2.64^\circ\text{C}$ for both heights of 3.6 m and 4.8 m, respectively. On the other hand, a chimney with a diameter of 200 mm achieved low temperatures ($P \leq 0.05$) (see Figure 3.7). The inlet temperature increased by 23.1°C and 30.9°C , relative to the initial temperature in the storage room for a chimney diameter of 300 mm, and for heights of 3.6 m and 4.8 m. Temperatures in the roof solar collector were observed on the inlets when the chimney was in operation since they influence the indoor environment. High temperatures for the chimney with a 300 mm diameter were due to the chimney extracting hot air from the roof solar collector. For a chimney with a diameter of 200 mm, the temperature increases were smaller, i.e., 3°C and 4.3°C , for 3.6 m and 4.8 m chimney heights, respectively. These marginally small temperature increases were due to the pressure that developed in the solar collector during the heating of air (Guo *et al.*, 2016), forcing the air into the inlets at irregular intervals. This causes a slight increase in the average temperature; however, if the 200 mm chimney developed adequate draft to extract hot air from the roof solar collector, the temperature increased significantly. This is evident from the temperature results produced by a chimney diameter of 300 mm, which had adequate suction power to extract hot air from the roof solar collector. Both the height and the diameter have an impact on the performance of the chimney. The 300 mm diameter chimney gave good results at a height of 4.8 m.

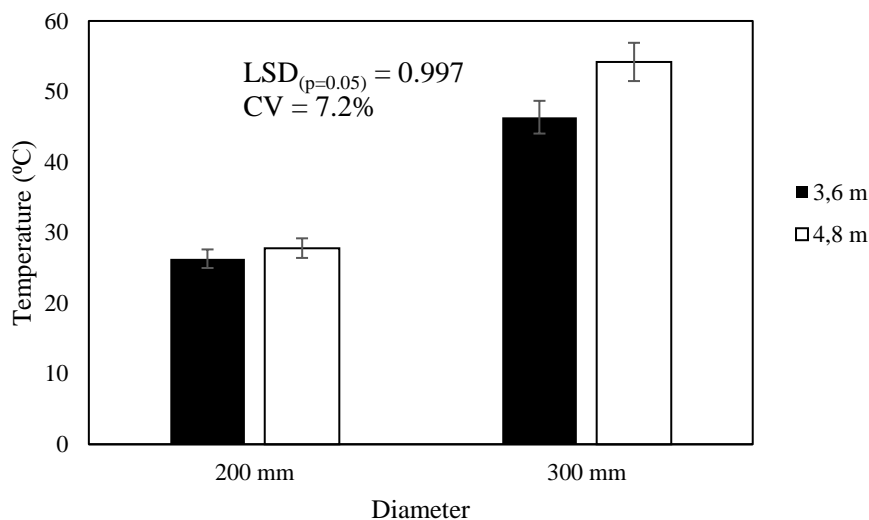

Figure 3.7 Temperature at the inlet

3.4.6 Temperature at the centre

The centre temperature was significantly higher for the chimney with a diameter of 300 mm, compared to a diameter of 200 mm ($P \leq 0.05$). Figure 3.8 shows that for both chimney diameters of 200 mm and 300 mm, all the heights induced similar temperatures. The temperature decreased from $54.2 \pm 2.64^\circ\text{C}$ at the inlet to $35.7 \pm 0.15^\circ\text{C}$ at the centre (see Figure 3.10). A decrease in temperature indicates the movement of air as it enters the inlet from the roof solar collector down to the centre of the storage, where the seeds are stored. When the size of the chimney is increased, the movement of air is observed through the temperature profile at different locations in the storage space. This is particularly so for chimneys with a diameter of 300 mm, since a bigger chimney diameter has a smaller resistance flow coefficient, resulting in high airflow volume and more draft (Ghulamchi *et al.*, 2016; Khan and Roy, 2017). However, the 300 mm chimney diameter, with the height of 4.8 m performed better than the rest of the chimney sizes.

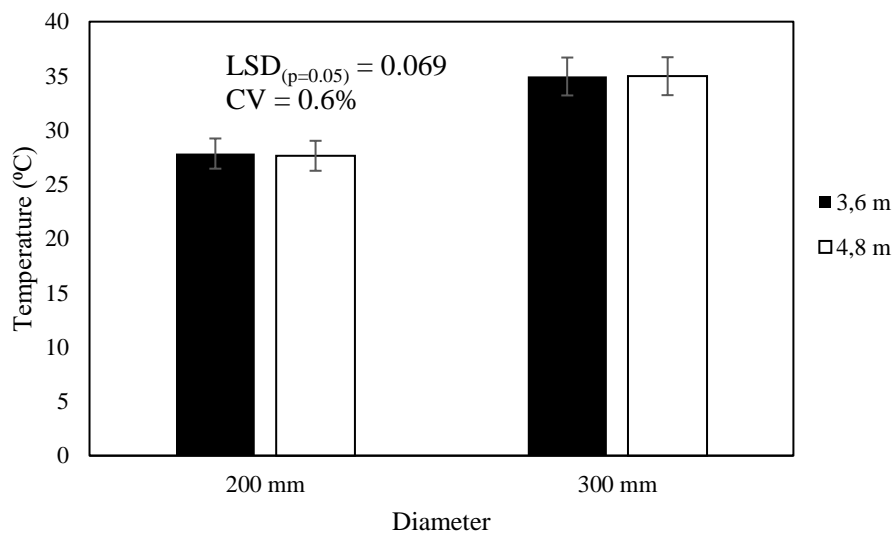

Figure 3.8 Air temperature at the centre of the storage

3.4.7 Temperature at the outlet

The temperature at the outlet of the storage is measured at the chimney inlet (which is the room outlet) at the base. For a 300 mm diameter chimney, the temperature of the air at the outlet is lower than the temperature at the centre of the storage, since the outlet is at the bottom. The temperature decreased from $35.7 \pm 0.15^\circ\text{C}$ at the centre to $31.8 \pm 0.16^\circ\text{C}$ at the outlet (see Figure 3.10). There is a significant difference between the results obtained for the different chimney sizes ($P \leq 0.05$) (see Figure 3.9). Larger chimney sizes performed better than smaller chimney

sizes. The longer and bigger the chimney is, the better the results, and that a 300 mm diameter chimney, with the height of 4.8 m, had greater ventilation rate, when compared to the rest of the chimney sizes explored in this study. The temperature is lower at the outlet than in the other positions in the storage room, since the outlet is at the lowest point. Therefore, when hot air enters the inlets from the roof solar collector, it cools until it exits through the outlet at the bottom. Furthermore, the solar chimney provides suction when the air column inside the chimney body is heated (Shi and Zhang, 2016; Ratanachotinun, 2016). In principle, hot air rises and the upward movement of air leaves a vacuum for the air beneath to fill, thus allowing a continuous flow of air in the chimney and the storage room (Shao *et al.*, 2016). The performance of the solar chimney is dependent on the size of the chimney; the higher the chimney, the better the results. Similarly, the larger the cross-sectional area, the higher the ventilation rate (Chung *et al.*, 2015; Jafari and Poshtiri, 2017). For the storage room under investigation, a chimney diameter having a diameter larger than 300 mm produces good results. It is similar to a chimney with a height of 3.6 m. However, increasing the diameter of the chimney further leads to a reverse flow, a case where air reverses its direction and moves back into the storage room, which is unwanted. The chimney, on the other hand, can be as high as it can be, although there is an optimum chimney height beyond which the draft no longer improves. This particular height was not achieved in the current study, which leaves an opportunity for conducting further investigations into this particular aspect.

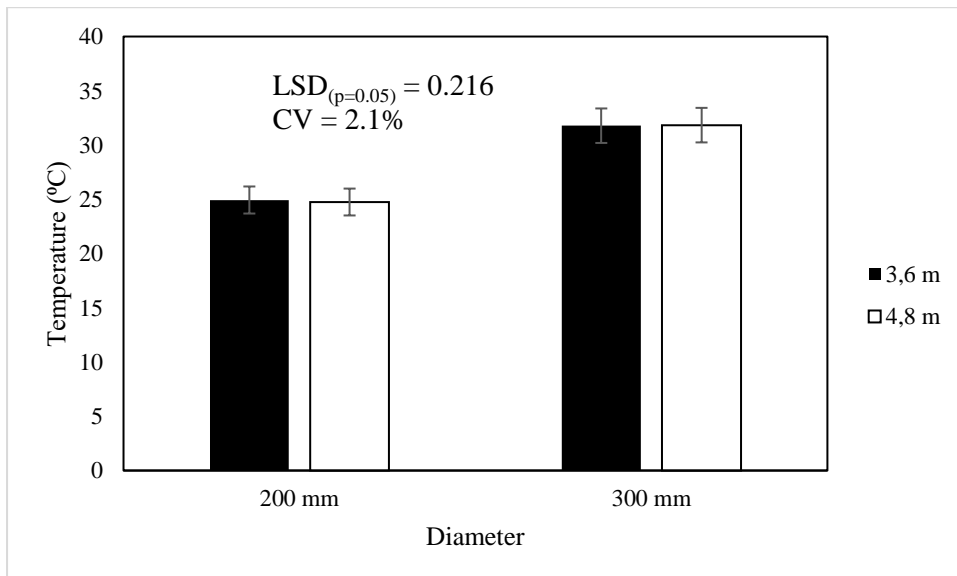

Figure 3.9 Outlet temperature

3.4.8 Temperature and relative humidity profile at different positions in the storage room

The air temperature at the inlet is higher than the rest of the positions, and as air flows down towards the centre of the storage room the temperature decreases. This was observed for the chimney with a diameter of 300 mm for both heights (see Figure 3.10). However, for a 200 mm diameter chimney, the temperature does not change, irrespective of the position in the storage room. In principle, the air cools as it sinks in space (Ming *et al.*, 2016; Ansari *et al.*, 2017), which implies that a chimney size with a diameter of 300 mm has an ability to circulate the air in the storage room and a chimney with a diameter of 200 mm does not induce air movement in a storage room. The relative humidity of a chimney diameter of 300 mm for both heights (3.6 and 4.8 m) increases from the inlet, in the centre and at the outlet. It is attributed to the cooling of air as it moves down the space of the storage room (see Figure 3.11). When the temperature decreases, the relative humidity tends to increase, since air with a low temperature has little capacity to hold moisture, resulting in high relative humidity (Mostafa *et al.*, 2015; Kraniotis and Nor, 2017). On the other hand, the chimney diameter of 200 mm had a high relative humidity in all the positions in the storage room. This is an indication that the air is still in the storage space, when a chimney diameter of 200 mm is used.

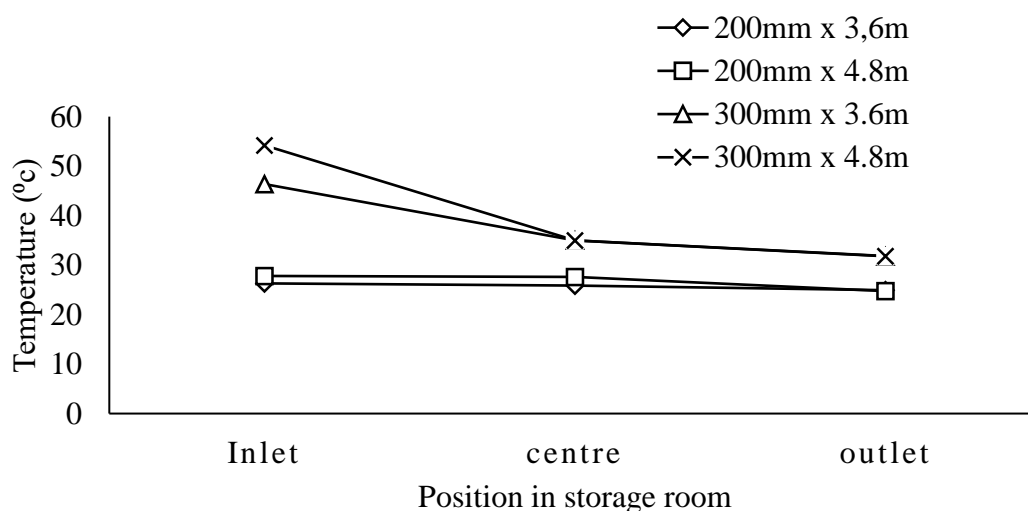

Figure 3.10 Temperature profile at different positions in the storage room

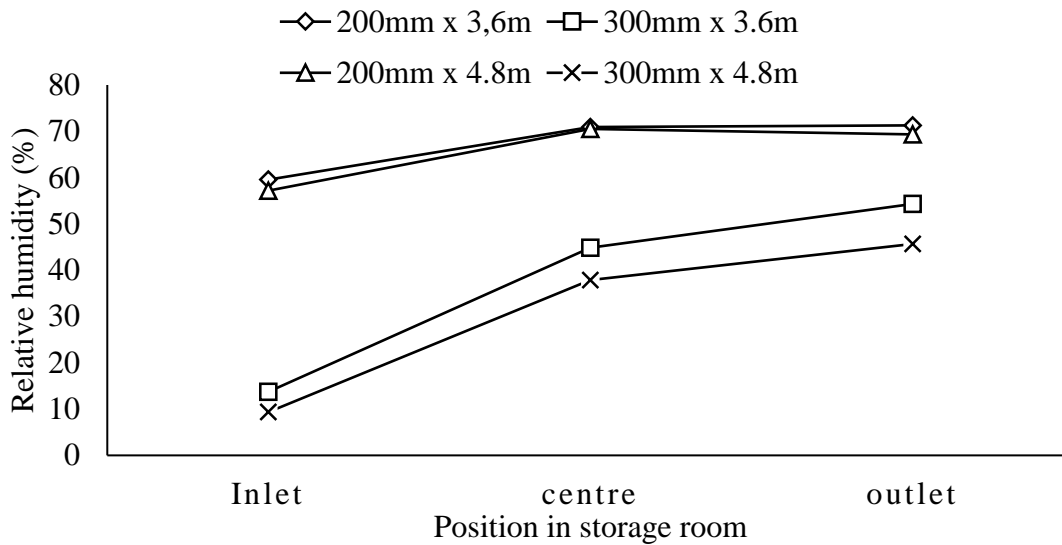

Figure 3.11 Relative humidity profile in different positions of the storage room

3.5 Conclusion

The ventilation rates achieved by a chimney with a diameter of 300 mm and a height of 3.6 m and 4.8 m chimney heights were $3.4 \text{ m}^3\cdot\text{m}^{-1}$ and $6.4 \text{ m}^3\cdot\text{m}^{-1}$, which was greater than the minimum recommended ventilation rate for stored seeds. Therefore, chimneys with a diameter of 300 mm and heights of 3.6 m and 4.8 m, meet the ventilation rate required for the storage of seeds. The response of the ventilation rate was found to be greater when the diameter was increase than when the height of the chimney increased. However, the optimum diameter was not reached in the studies reported by (Bassiouny and Koura, 2008; Alzaed and Mohamed, 2014). It is therefore necessary to further this study by exploring chimneys that are bigger than those used in the current study, using Computational Fluid Dynamic (CFD) models. It was found that a diameter of 300 mm was able to extract hot air from the solar collector and circulate it inside the storage space, but a diameter of 200 mm did not. The relative humidity increased from 9.4% to 45.7% at the outlet, from a height of 3 m at the inlets to the ground level at the outlet. Excessive cooling occurs when the air is circulated, and thus, the vertical distance between the inlets and outlets should be reduced, to keep relative humidity inside the storage as low as possible. The temperature was highest at the inlet and lowest at the outlet, whereas the relative humidity was lowest at the inlet and highest at the outlet. The highest reduction in relative humidity was 60.3%, 31.8%, and 24%, at the inlet, centre and outlet, respectively, for a chimney size of 300 mm x 4.8 m. The storage facility can be tested under a wide range of external environmental conditions, to further observe its performance. The chimney size with

a diameter of 300 mm and a height of 4.8 m was able to lower the relative humidity in the storage room and a naturally-ventilated seed storage will be developed based on the aforementioned chimney size.

3.6 References

- Adetumbi, J. 2014. Effect of storage environment and materials on moisture content and viability of maize (zeamays) seeds in storage *Applied Tropical Agriculture* 1(14):89-94.
- Afonso, C and Oliveira, A. 2000. Solar chimneys: simulation and experiment. *Energy and Buildings* 32(1):71-79.
- Ali, SWM. 2010. *Experimental and Numerical Study of Solar Chimney for Ventilation*. Report No. 1431. University of Kufa, Kufa, Iraq.
- Alzaed, AN and Mohamed, HA. 2014. Experimental study of solar chimney for ventilation in hot arid region. *International Journal of Engineering and Innovative Technology (IJEIT)* 4(4):140-144.
- Ansari, Z, Shaik, A, Iqbal, MAS, Anwar, MT and Zakir, MFA. 2017. Air Conditioning Using Radiant Cooling System. *International Journal of Research and Engineering* 4(4):101-106.
- Asadi, S, Fakhari, M, Fayaz, R and Mahdavi Parsa, A. 2016. The effect of solar chimney layout on ventilation rate in buildings. *Energy and Buildings* 123(2016):71-78.
- Bassiouny, R and Koura, NS. 2008. An analytical and numerical study of solar chimney use for room natural ventilation. *Energy and Buildings* 40(5):865-873.
- Charvat, P, Jicah, M and Stetina, J. 2004. *Solar Chimneys for Ventilation and Passive Cooling*. Report No. 53. World Renewable Energy Congress, Denver, USA.
- Chattha, SH, Jamali, LA, Ibupoto, KA and Mangio, H. 2012. Effect of different packing materials and storage conditions on the viability of wheat seed (TD-1 variety). *Science, Technology and Development* 31(1):10-18.
- Chung, LP, Ahmad, MH, Ossen, DR and Hamid, M. 2015. Effective solar chimney cross section ventilation performance in Malaysia terraced house. *Procedia-Social and Behavioral Sciences* 179(2015):276-289.
- Everson, CS, Mengistu, MG and Gush, MB. 2013. A field Assessment of the agronomic performance and water use of *Jatropha curcas* in South Africa. *Biomass and Energy* 59(2013):59-69.

- Exell, RHB. 2017. Basic design theory for a simple solar rice dryer. *International Energy Journal* 1(2):1-14
- Farshadmanesh, P, Modares, M and Mohammadi, J. 2014. *Impact of Chimney-top Appurtenances on Flue Gas Flow*. Report No. 02169-7471. Illinois Institute of Technology, Chicago, USA.
- Guo, P, Li, J, Wang, Y and Wang, Y. 2016. Evaluation of the optimal turbine pressure drop ratio for a solar chimney power plant. *Energy Conversion and Management* 108(2016):14-22.
- Hassanein, SA and Abdel-Fadeel, WA. 2012. Improvement of natural ventilation in building using multi solar chimneys at different directions. *Journal of Engineering Sciences* 40(6):1661-1677.
- Hollowell, CD. 2013. *Ventilation Systems*. Report No. 5. Baltic Sea Region, Rostock, Germany.
- Huynh, BP. 2010. *Natural Ventilation Induced by Solar Chimneys*. Report No. 17. Faculty of Engineering and IT University of Technology Sydney, Sydney, Australia.
- Imran, AA, Jalil, JM and Ahmed, ST. 2015. Induced flow for ventilation and cooling by a solar chimney. *Renewable Energy* 78(2015):236-244.
- International Rice Research Institute. 2016. Storage Systems. [Internet]. International Rice Research Institute, Los Banos, USA. Available from: <http://www.knowledgebank.irri.org/step-by-step-production/postharvest/storage/grain-storage-systems>. [Accessed: 26 April 2016].
- Janjai, S and Tung, P. 2005. Performance of a solar dryer using hot air from roof-integrated solar collectors for drying herbs and spices. *Renewable Energy* 30(14):2085-2095.
- Jindal, VK and Gunasekaran, S. 2017. Estimating air flow and drying rate due to natural convection in solar rice dryers. *International Energy Journal* 4(2):1-9.
- Khedari, J, Boonsri, B and Hirunlabh, J. 2000. Ventilation impact of a solar chimney on indoor temperature fluctuation and air change in a school building. *Energy and Buildings* 32(1):89-93.
- Kraniotis, D and Nore, K. 2017. Latent heat phenomena in buildings and potential integration into energy balance. *Procedia Environmental Sciences* 38(2017):364-371.
- Kumar, J, Raj, A and Sharma, HM. 2017. Enhancement of natural ventilation using solar chimney: a numerical investigation. *International Journal of Advanced Engineering Research and Science (IJAERS)* 4(3):252-257.

- Lal, S, Kaushik, SC and Bhargava, PK. 2013. A case study on solar chimney-assisted ventilation for residential building in India. *International Journal of Energy Sector Management* 7(4):478-490.
- Li, A, Jones, P, Zhao, P and Wang, L. 2004. Heat transfer and natural ventilation airflow rates from single-sided heated solar chimney for buildings. *Journal of Asian Architecture and Building Engineering* 3(2):233-238.
- Mathur, J, Bansal, NK, Mathur, S, Jain, M and Anupma. 2006. Experimental investigations on solar chimney for room ventilation. *Solar Energy* 80(8):927-935.
- Mehani, I and Settou, N. 2012. Passive cooling of building by using solar chimney. *World Academy of Science, Engineering and Technology* 69(9):521-525.
- Mekkawi, GM and Elgendy, RA. 2016. *Solar Chimney for Enhanced Natural Ventilation Based on Cfd-Simulation for a Housing Prototype in Alexandria, Egypt* Report No. 978-93-86083-57-9. Alexandria University, Alexandria, Egypt
- Ming, T, Gong, T, de Richter, RK, Liu, W and Koonsrisuk, A. 2016. Freshwater generation from a solar chimney power plant. *Energy Conversion and Management* 113(189-200).
- Mostafa, A, Yamazawa, H, Uosif, M and Moriizumi, J. 2015. Seasonal behavior of radon decay products in indoor air and resulting radiation dose to human respiratory tract. *Journal of Radiation Research and Applied Sciences* 8(1):142-147.
- Moummi, N, Chabane, F, Benramache, S and Brima, A. 2013. Thermal efficiency analysis of a single-flow solar iar heater with different mass flow rates in a smooth plate. *Frontiers in Heat and Mass Transfer (FHMT)* 4(1):1-6.
- Nakielska, M and Pawłowski, K. 2017. *Increasing natural ventilation using solar chimney*. Report No. 01051. EDP Sciences, Les Ulis, France.
- Park, D and Battaglia, F. 2015. Application of a wall-solar chimney for passive cooling of dwellings. *ASME/JSME/KSME 2015 Joint Fluids Engineering* 2(2015):1-8.
- Ratanachotinun, J, Kasayapanand, N, Hirunlabh, J, Visitsak, S, Teekasap, S and Khedari, J. 2016. A design and assessment of solar chimney of bioclimatic house wall and roof for construction in the housing market of Thailand. *Building Services Engineering Research and Technology* 37(6):694-709.
- Ravanfar, A. 2013. *Simulation Study of Solar Chimney Assisted Solarium*. Report No. 59. Iran University of Science and Technology, Ontario, Canada.
- Reed, C. 2009. *US. Corn Storage In Tropical Climates*. Report No. 13. International Grains Program Kansas State University, Washington, DC, USA.

- Shao, J, Chen, H and Zhu, T. 2016. Solar energy block-based residential construction for rural areas in the West of China. *Sustainability* 8(4):362.
- Shi, L and Zhang, G. 2016. An empirical model to predict the performance of typical solar chimneys considering both room and cavity configurations. *Building and Environment* 103(250-261).
- Siva Reddy, V, Premalatha, M and Ranjan, K. 2012. Experimental studies on solar chimney for enhanced ventilation. *International Journal of Sustainable Energy* 31(1):35-42.
- Tan, AYK and Wong, NH. 2012. Natural ventilation performance of classroom with solar chimney system. *Energy and Buildings* 53(2012):19-27.
- Tan, AYK and Wong, NH. 2013. Parameterization studies of solar chimneys in the tropics. *Energies* 6(1):145-163.
- Weather2. 2016. Pietermaritzburg Climate History. [Internet]. Weather2, Edinburgh, Scotland. Available from: <http://www.myweather2.com/City-Town/South-Africa/Pietermaritzburg/climate-profile.aspx>. [Accessed: 10 May 2016].
- Wei, D, Qirong, Y and Jincui, Z. 2011. A study of the ventilation performance of a series of connected solar chimneys integrated with building. *Renewable Energy* 36(1):265-271.
- Windfinder. 2016. Wind Weather Statistics. [Internet]. Windfinder, Amsterdam, the Netherlands. Available from: <http://www.windfinder.com/windstatistics/pietermaritzburg>. [Accessed: 15 May 2016].
- Yan, Z, Guang-e, J, Xiao-hui, L and Qing-ling, L. 2011. Research for ventilation properties of solar chimney with vertical collector. *Procedia Environmental Sciences* 11(2011):1072-1077.

4. EVALUATING SEED MOISTURE, GERMINATION AND VIGOUR OF THE STORE MAIZE SEEDS

Abstract

The performance of a solar energy-assisted seed storage room was evaluated. The structure was made of a solar collector, which was responsible for heating the ambient air before the air enters structure and the chimney. The chimney was responsible for circulating air inside the structure and inlets, for allowing heated air into the structure. A residential room with a volume of 22 m³ was retrofitted with a solar collector, inlets and a chimney. To compare the performance of this modified storage room, a room with a similar capacity and without the retrofitted components (control storage room) was used. Twelve 8 kg bags of maize were stored in each storage room for a period of three months. Maize samples were taken every two weeks to determine germination, moisture content and seed vigour. The temperature and relative humidity was measured during storage. The relative humidity in the control storage was significantly higher ($P \leq 0.05$) ($60.6\% \pm 5.87$) than in the modified storage ($40.1\% \pm 3.21$) during the day. However, at night, the relative humidity in the control storage room was significantly lower ($P \leq 0.05$) ($58.5\% \pm 7.32$) than in the modified storage ($63.7\% \pm 6.28$). The relative humidity in the modified storage room increased from 40.1% during the day to 63.7% at night. The relative humidity in the control storage room decreased slightly from 60.6% to 58.5% during the day and night. The increase in relative humidity in the modified storage between day and night is due to the high relative humidity outdoor air entering the storage room at night during operation. The outdoor relative humidity where the experiment was conducted was high. The seed moisture content in the modified storage facility was significantly lower ($P \leq 0.05$) ($12.6\% \pm 0.21$) than in the control storage room ($13.3\% \pm 0.52$). The seed moisture content in the modified storage room decreased from 12.6% to 12.4%, whereas in the control room, seed moisture content increased from 12.6% to 13.8% in three months. The seed germination rate obtained after three months of storage in the modified storage room was significantly higher ($P \leq 0.05$) ($98.5\% \pm 0.85$) than in the control storage room ($96.8\% \pm 1.49$). The seed vigour obtained in the modified storage room was significantly higher ($93.6\% \pm 0.35$) than in the control room ($91.7\% \pm 2.08$) ($P \leq 0.05$). Seed stored in the control storage lost vigour at a faster rate, compared to the seeds stored in the modified storage room. Therefore, the modified naturally-ventilated seed storage room maintained seed quality better than the control storage room.

4.1 Introduction

Seed moisture content, vigour and germination are some of the most important parameters for assessing seed quality, especially, for plant breeders. To preserve the quality of the seeds, proper storage facilities are required. Factors that affect the quality of the stored seeds are micro-organisms, temperature, relative humidity, moisture content, carbon dioxide, insects, mites, rodents, the characteristics of the stored seed, the geographical location of the structure, the structure of the seed facility and oxygen level (Roberts, 1972; Jayas and White, 2003; Gonzales *et al.*, 2009; Lawrence and Maier, 2010; Suleiman *et al.*, 2013; Delouche *et al.*, 2016; Rao *et al.*, 2017). The presently-available traditional structures in most sub-Saharan African countries are made of wheat straw, which are permissible to rodents, pests, and insects. Other traditional structures are underground storage structures, bamboo/reed structures, masonry structures and earthen storage structures which present different problems (Adejumo and Raji, 2007; Sharon *et al.*, 2014), and all the afore-mentioned problems affect the quality of stored seeds. The germination and seed vigour of maize seeds that were stored, using traditional methods, were studied for a period of one year (Govender *et al.*, 2008). The seeds were stored in plastic bags in a general storage room, where there was no air conditioning. The temperature fluctuated between 35 and 37°C with high exposure to insect damage. In this type of storage room, maize germination dropped from 88.7% to 0.0% and there was a loss of vigour. In another study, maize seeds stored in hermetic bags, with moisture content between 20% and 22% and under the temperature of 30°C, had a low vigour and germination, compared to the maize seeds stored at a moisture content of 14% for the same duration of 75 days (Weinberg *et al.*, 2008). This study showed the negative effects of high moisture during storage.

When the levels of relative humidity and temperature are simultaneously high, there is a high rate of physiological activity in seeds, resulting in faster deterioration (Coasta *et al.*, 2013; Coradi *et al.*, 2016). On the other hand, a low relative humidity and low temperature decrease the microorganism infestation (Chiu *et al.*, 2002; Jian and Jayas, 2012; Gradeci *et al.*, 2017). Maize seeds were stored at a temperature of 25°C, a relative humidity of 75% and 85% and a 13.8% moisture content for a period of 120 days. Seeds stored at a relative humidity of 85% lost their germination ability completely after 30 days, while those that were stored at a relative humidity of 75% lost their germination ability after 120 days (Moreno-Martinez *et al.*, 1998). Maize seeds were also subjected to three storage conditions (20°C + 45-50% RH, 25°C + 65-70% RH, and 30°C + 90-95% RH) for the duration of 420 days (Joao Abba and Lovato, 1999). At 30°C + 90-95% RH, the seeds lost their viability and vigour completely. Furthermore, the

equilibrium moisture content increased from 10.5% to 17% and the 20°C + 45-50% RH conditions were found to be favourable for storing maize seeds for the period of one year. The conditions (25°C + 65-70% RH) were recommended for the storage of seeds for no longer than four months. This shows that an elevated temperature and relative humidity reduces the quality of the stored seed at a faster rate. Eighteen crop species were stored for 23 years at a temperature of 20.3 °C ± 2.3 and a relative humidity of 50.3% ± 6.3. It was found that maize sustained its viability for 19 years (Nagel and Börner, 2010). Maize seeds were stored under two storage conditions of temperature of 25°C and a relative humidity of 75% RH and at a temperature of 12°C and a relative humidity of 60% RH, and the seed vigour was monitored during storage (Šimić *et al.*, 2006). Seed stored at 12°C and at a 60% RH had little decline in seed vigour, compared to the seed store at 25°C and a 75% RH. At a higher temperature and relative humidity, seeds lose their quality at a greater rate, while the opposite occurs at low temperature and relative humidity.

It is thus necessary to use a seed storage facility that reduces the relative humidity during storage, to reduce the moisture content of stored seeds. Sharon *et al.* (2014) recommended that after harvesting, seeds should be dried to a safe moisture content for storage. Maintaining a safe seed moisture content during storage helps to improve the storability of seeds and lowers the risk of seed spoilage during storage (White *et al.*, 2010). A safe moisture content during storage is <15% wet basis (Magan and Aldred, 2007; Somavat, 2017). However, seeds are harvested at a moisture content of 20-30% (Tefera, 2012). It is strongly recommended that seeds should be dried to less than 14% prior to storage (Coradi *et al.*, 2016; Soponronnarit, 2017). The storage facility should be able to keep within a safe moisture content limit.

Therefore, the objective of this study was to test the developed naturally-ventilated seed storage facility for preserving the quality of the stored seeds, namely, germination, seed vigour and moisture content.

4.2 Materials and Methods

4.2.1 Description of the solar energy-assisted seed storage facility

The structure consists of the solar collector (polycarbonate sheets), which has an area of 11 m² covering the entire roof, the inlet galvanised steel pipes to the room, with a total area 0.066 m², and an outlet chimney, with an area of 0.071 m² (diameter) and a height of 4.8 m. The volume of the storage facility is 22 m³ (see Figure 4.1).



Figure 4.1 Picture (a) on the left shows the modified storage and picture (b) on the right shows the solar collector system for heating incoming air.

4.2.2 Experimental Layout

A yellow maize variety was used in this experiment. Two storage rooms, namely, a control and a modified storage, were evaluated. Twelve bags of seeds were loaded in each of the storage type. Each bag weighed 8 kg. Only three seed bags were sampled in each storage room for germination, seed vigour and moisture content determination and Figure 4.2 shows the experimental design.

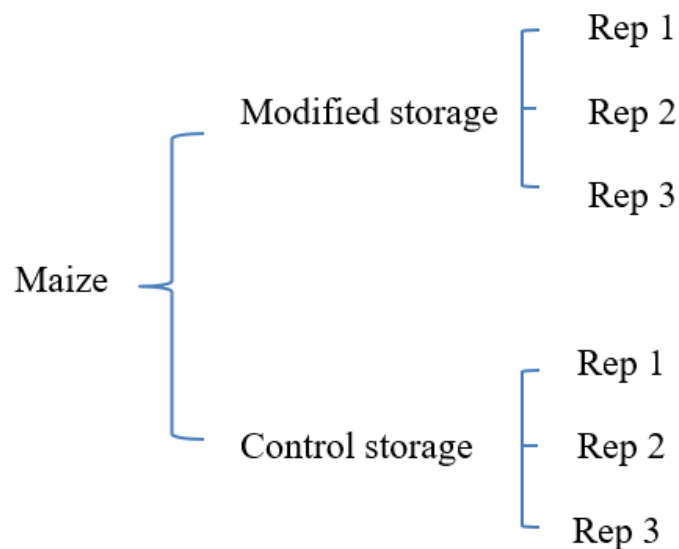

Figure 4.2 Experimental design

4.2.3 Data collection

4.2.3.1 Moisture content determination

According to the Official Method of the association of Official Analytical Chemistry, grain moisture content is determined as follows (Horwitz *et al.*, 1970):

- (a) grain is ground to pass a 1 mm sieve,
- (b) 2 g of ground grain is weighed,
- (c) 2 g is dried for one hour at 130°C,
- (d) moisture content is expressed on wet basis.

4.2.3.2 Standard germination

Fifty seeds were germinated at a temperature of 25°C under no light conditions in the germinating chamber (Janmohammadi *et al.*, 2008; iGrow Corn, 2016). Seeds were checked for germination every day for seven days, from the third day. The seed is counted as being germinated when the radicle has protruded to a length of 3 mm. Percentage germination was calculated, using the following equation:

$$\%Germination = \frac{\text{Number of seedling emerged}}{\text{Number of seeds sown}} \times 100 \quad (4.1)$$

4.2.3.3 Seed vigour by Accelerated Ageing Test

The Accelerated Ageing Test was carried out to test whether the seed had the strength to germinate with success under harsh conditions consisting of high temperature and relative humidity. Seeds were exposed to a relative humidity of 96%, a temperature of 45°C for the duration of 72 hours in the AA machine (Woltz and TeKrony, 2001; Society Commercial Seed Technologists, 2016; Seed Check, 2017). After accelerated ageing, the seeds were subjected to standard germination.

4.2.3.4 Temperature and relative humidity measurements

Temperature and relative humidity were recorded using the HOBO U23 Pro v2 Temperature/Relative Humidity Data Logger, with 0.2°C and 2.5% accuracy at the intervals of 30 minutes every day, from 20 March 2017 through to 19 June 2017. The temperature and air relative humidity were recorded inside the seed bags (2) and at the center of the storage room (3) for both storage types (see Figure 4.3). The quality parameters of maize (germination, moisture content and vigour) were measured at two-week intervals, for the entire duration of storage.

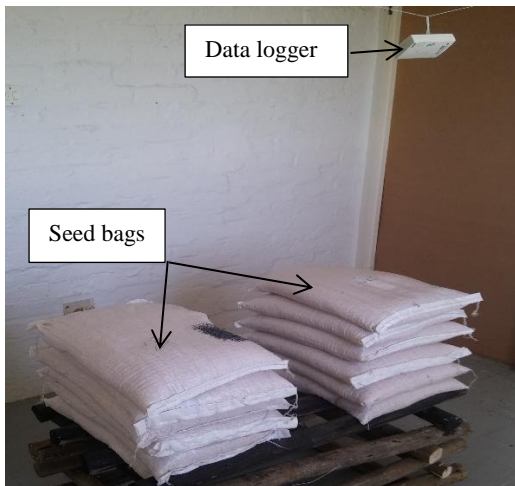

Figure 4.3 Seed bags in the storage

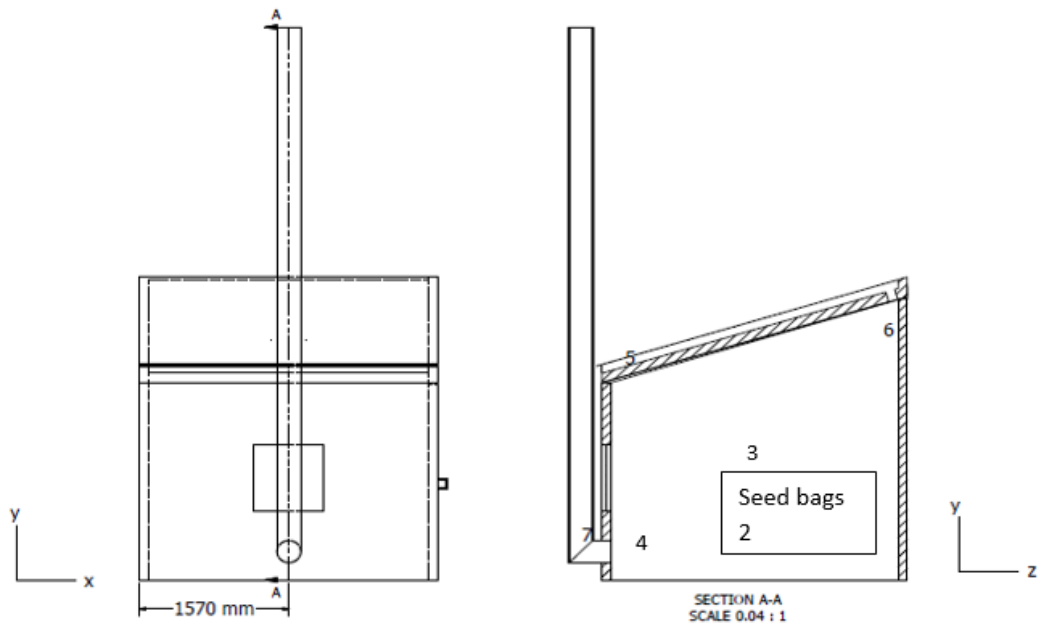

Figure 4.4 In position 7, (chimney duct) is where the air flow velocity is measured, whereas, in points-2 (inside seed bags), 3 (room centre), 4 (outlet) and 6 (air inlet) is where temperature/relative humidity is measured, respectively at $x = 1.57$ m

4.3 Data Analysis

An analysis of variance for temperature, relative humidity, moisture content, standard germination and vigour was carried out using Genstat18 and Excel2016, using a 5% ($P \leq 0.05$) level of significance.

4.4 Results and Discussion

This section discusses the results obtained with regard to the performance of the storage facility, compared to the control storage facility.

4.4.1 Air relative humidity and temperature measured at the centre of the storage facility and inside the bags containing seeds during the day

Table 4.1 shows the changes in air temperature inside both storage facilities. There was a rapid variation of the air temperature in both storage rooms throughout the storage period, which was caused by the rapid changes from the outdoor environmental conditions. The difference between the air temperature in the control and modified storage rooms was significant ($P \leq 0.05$), where the mean temperature in the modified room was greater ($24.4^{\circ}\text{C} \pm 3.89$) than the mean air temperature during the day in the control room ($19.5^{\circ}\text{C} \pm 2.99$) (see Table 4.1). The average temperature was 24.4°C over the three months of storage period, from the March through to June, which are cold months of the year, and this is the reason that the average temperature in the modified storage room is low.

The average temperatures and the centre position in the modified storage room are higher during the day, since the solar collector is heating the air that enters, in the presence of solar radiation. Between March and April, the temperatures were as high as 35°C in the storage room, however, in May and June, temperatures dropped to below 27°C inside the modified storage room. Temperatures in the control storage room were always below the modified storage (see Figure 4.5), which implies that the modified storage is operating as expected.

Temperature and relative humidity are important and work together during storage (Delouche *et al.*, 2016). At a temperature of 20°C and a relative humidity of 45-50% , the seeds maintained their quality traits (viability and vigour) for one year (Joao Abba and Lovato, 1999). In the current study, the modified storage achieved a relative humidity of $40.1\% \pm 3.21$, which is less than 45-50% (24.4°C), and this makes it possible for the seeds to be stored in the modified storage room assuming the current conditions prevail, under day conditions, for one year.

Table 4.1 The summary of results of temperature and relative humidity in the centre and inside the seed bags, moisture content, germination and seed vigour in the control and modified room

	Centre Temp	Centre RH	Bag Temp	Bag RH	Moisture	Germination	Vigour
Cont.room Av.D	19.5±2.99	60.6±5.87	21.4±2.67	66.1±7.34	13,3±0.52	96,8±1.49	91,7±2.08
Mod.room Av.D	24.4±3.89	40.1±3.21	26.7±2.70	44.4±6.11	12,6±0.21	98,5±0.85	93,6±0.35
Cont.room.Av.N	21.4±4.25	58.5±7.32	22.4±5.36	52.7±8.65	13,3±0.52	96,8±1.49	91,7±2.08
Mod.room.Av.N	22.2±6.12	63.7±6.28	20.9±4.11	57±6.07	12,6±0.21	98,5±0.85	93,6±0.35
CV (%).D	15.8	17.6	11.2	16,2	1,5	3,1	1,6
CV (%).N	10.5	14.5	12.7	16.7	1,5	3,1	1,6
p value.D	<0.001	<0.001	<0,001	<0,001	0,002	0,012	0,022
p value. N	0.001	<0.001	<0.001	0.002	0,002	0,012	0,022
LSD(p=0,05).D	1.008	2,585	0,784	3.090	0,424	1,302	1,598
LSD (p=0.05).N	0.695	2.341	0.835	2.665	0,424	1,302	1,598

Where CV = coefficient of variation; LSD = least significant difference at $p = 0.05$; Cont.room Av = average value in the control room; Mod.room Av = average value in the modified storage; D = during the day; N = at night.

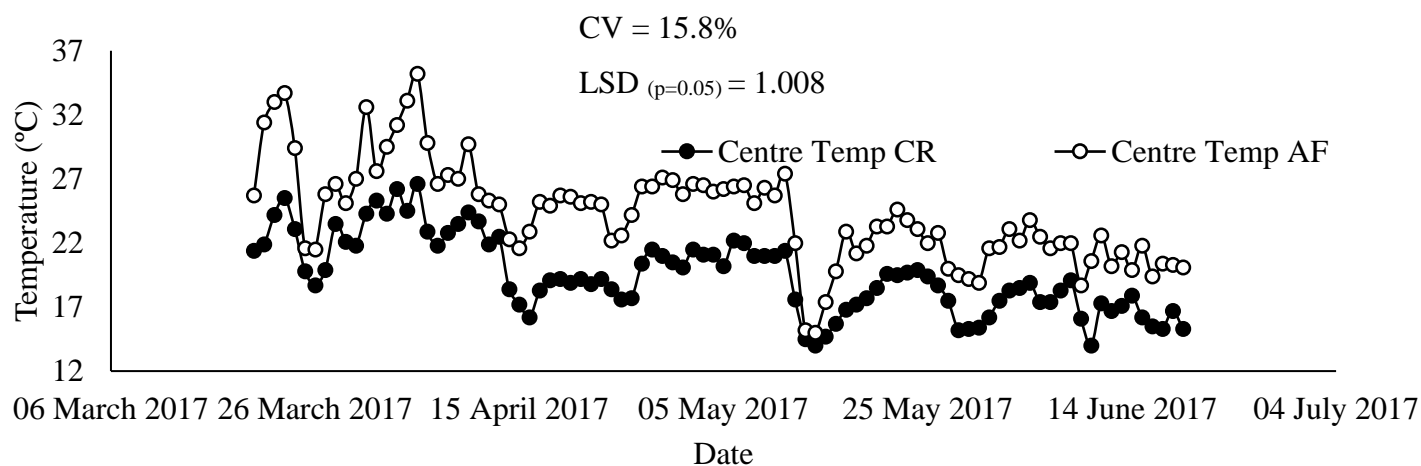

Figure 4.5 The temperature at the centre of the control room and modified room, during the day

The average relative humidity during the day in the modified storage room ($40.1\% \pm 3.21$) is lower than average relative humidity in the control room during the day ($60.6\% \pm 5.87$) over the entire period of storage (see Figure 4.6). There is a significant difference ($P \leq 0.05$) between the relative humidity in the modified and the control storage room (see Table 4.1). From March through to June, the relative humidity declines, since these are the cold months of the year (Mallory, 2015). Brownfield and Seeds (2006) reported that the 74% relative humidity of the seed, combined with a 12% moisture content, is good for enhancing shelf-life and relative humidity achieved in the current study is below 74%. The results showed that the levels of relative humidity were below 74% in both the modified and control storage rooms and inside the seed bags. A study carried out by Moreno-Martinez *et al.* (1998) showed that storing seeds at a moisture content as high as 85% accelerated deterioration. Maize stored at a temperature of 25°C and 80% relative humidity can be kept for five months in the storage room studied by (Lee *et al.*, 2006). Maize stored in both storage rooms qualifies to be stored for five months, since the conditions 24.4°C + 40.1% RH, 19.5°C + 60.6% RH, for the modified and control storage rooms, respectively are in agreement with the results obtained by Lee *et al.* (2006). However, for the prolonged storage of maize seeds (one year), the conditions obtained from control room will not be conducive, and this is attributed to the previous study carried out by Joao Abba and Lovato (1999). In their study, they found out that maize could be stored for a year at a temperature of 20°C and at a relative humidity of 45-50% RH.

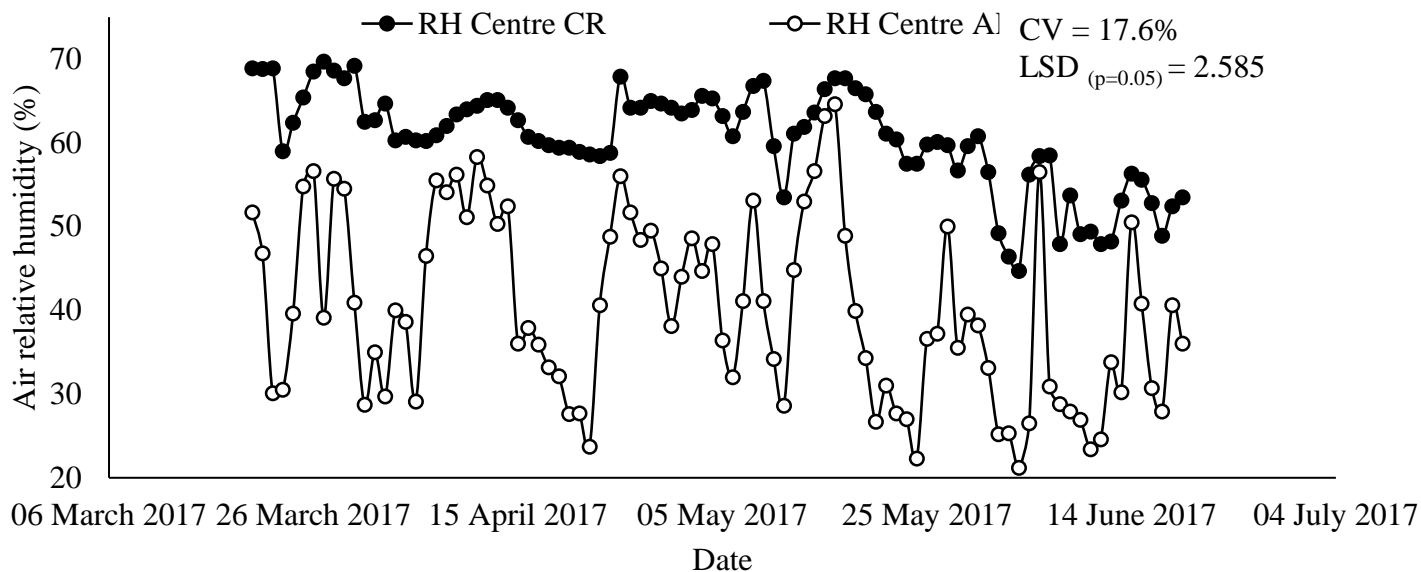

Figure 4.6 Air relative humidity at the centre of the control room (CR) and modified room (AF) during the day

Temperatures inside the seed bags in the modified storage room are higher than the temperature inside the seed bags in the control storage room ($P \leq 0.05$). This is observed in Figure 4.7. There is a significant difference, as the average temperature in the modified room is $26.7^{\circ}\text{C} \pm 2.7$ and is greater than the average temperature in the control storage room (21.4°C). At elevated temperatures and relative humidity, seeds tend to lose viability and vigour quicker, according to Šimić *et al.* (2006) and Matthes *et al.* (2016), and seeds stored at $12^{\circ}\text{C}/60\%$ aged slower than seeds stored at $25^{\circ}\text{C}/75\%$. The modified storage had an average temperature of 26.7°C , which was measured when the average relative humidity was 40.1%. The effect of an elevated temperature is masked by a low relative humidity. Jelle (2003) reported that the storage temperature varies widely provided that the seeds are dried to a safe storage moisture and that the relative humidity does not shift the equilibrium moisture during storage. The effect of temperature during storage is exaggerated when seeds are stored above a safe moisture content ($<14\%$) (Mira *et al.*, 2015). For instance, Suleiman *et al.* (2013) reported that for seeds kept at a 16% moisture content and at a temperature of 32°C and 35°C , seeds stored at a temperature of 35°C deteriorated quicker than seeds stored at a temperature of 32°C . In short, at higher temperatures, seed quality losses are high. Similar results were obtained by Wang (2015), where moisture content used was higher (35%) and at temperatures of 20°C , 8°C and 4°C . Nevertheless, from the current study the storage moisture content was below 13% for the

modified storage room, which makes it safe to store seeds for the purpose of quality preservation. However, temperature still plays a role on the quality of the seeds. The temperature inside the seed bags ($26.7^{\circ}\text{C} \pm 2.70$) is slightly higher than the air temperature at the centre ($24.4^{\circ}\text{C} \pm 3.89$) near the seed bags, which is due to the heat of respiration of seeds during storage and which rises the temperature between the seeds (Jian *et al.*, 2015; Martin *et al.*, 2015).

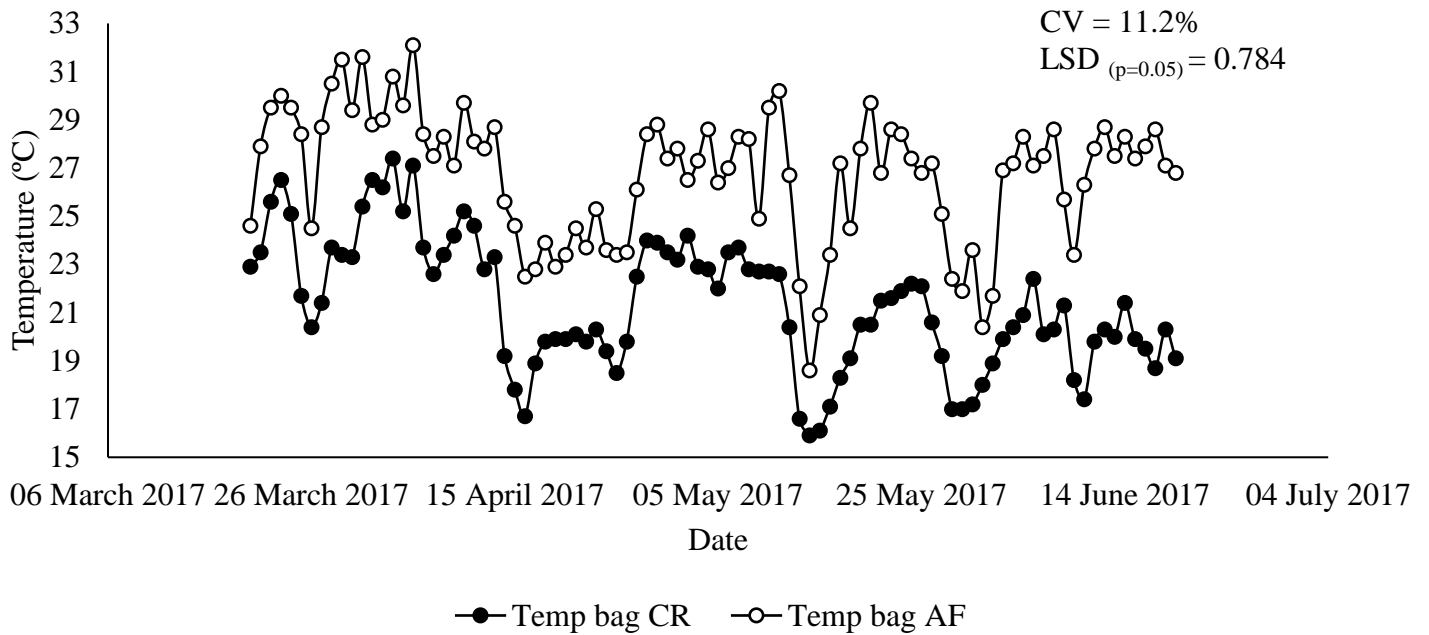

Figure 4.7 The temperature of the seeds in the bag in the control room and in the modified room during the day

Seed bags stored in the modified storage room had a lower relative humidity ($44.4\% \pm 6.11$) than seed bags stored in the control storage room ($66.1\% \pm 7.34$) (see Figure 4.8), since the modified storage facility had hot air coming in during the day. The difference between the relative humidity in the control and modified storage facility is significant ($P \leq 0.05$). In the study carried out by Nagel and Börner (2010), maize seeds were found to remain viable for 19 years at a $20.3^{\circ}\text{C} \pm 2.3$ and $50.3\% \pm 6.3$ relative humidity. The relative humidity obtained from the control storage room was 66.1%, which exceeds 50.3%; however, in the modified storage room it was 44.4%. Therefore, there is a great chance of improving the longevity of seeds when they are stored in the modified storage room, when one considers the results obtained by Nagel and Börner (2010).

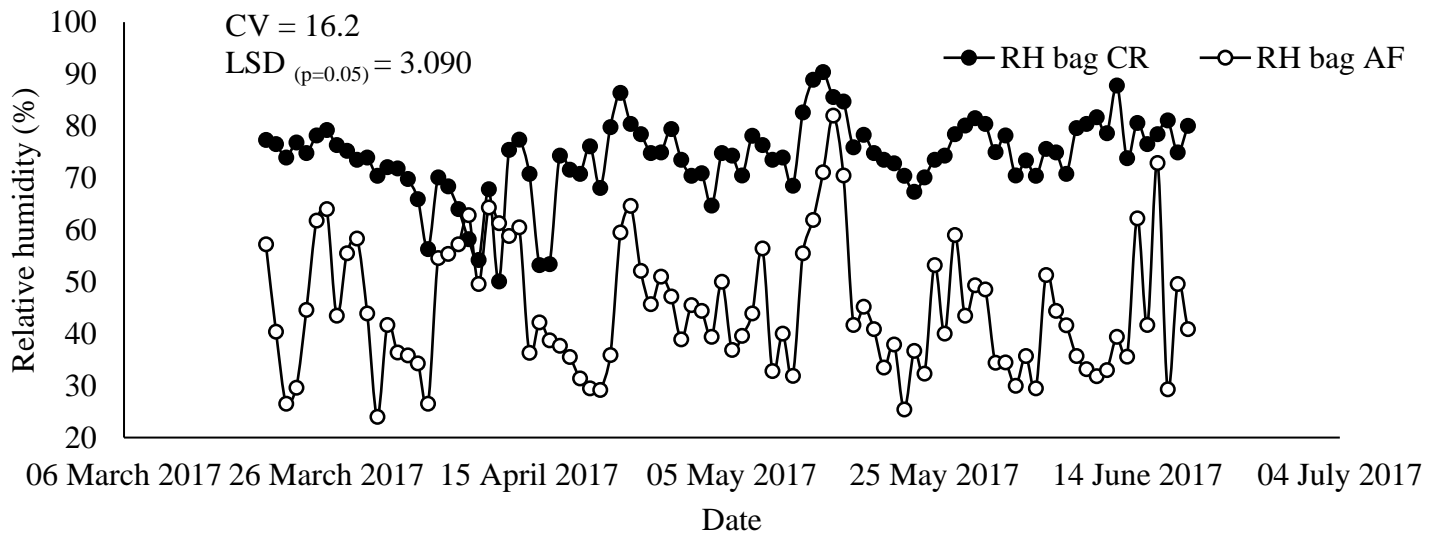

Figure 4.8 Seed bag air relative humidity for control room (CR) and modified room (AF) during the day

4.4.2 Air relative humidity and temperature at the centre and in the bag containing seeds at night

At night, the temperature in the modified storage room decreased below the temperature in the control storage room. The decrease in temperature is attributed to the low ambient air temperature introduced into the storage room at night, since the solar collector does not operate at this hour of the day, due to the absence of solar radiation. There is a significant difference ($P \leq 0.05$) between the temperatures in the modified and control storage rooms. The average seed bag temperatures in the control and modified storage room were found to be $22.4^{\circ}\text{C} \pm 5.36$ and $20.9^{\circ}\text{C} \pm 4.11$, respectively, (see Figure 4.9). The average temperature during the day in the modified storage room was higher ($24.4^{\circ}\text{C} \pm 3.89$) than the average temperature at night ($19.5^{\circ}\text{C} \pm 2.99$). However, the results obtained from the control storage room show that the average temperature during the day was slightly lower ($19.5^{\circ}\text{C} \pm 2.99$) than the average temperature at night ($21.4^{\circ}\text{C} \pm 4.25$).

Seeds were tested for vigour, germination and moisture when stored at 4°C , 25°C and 40°C under a constant relative humidity of 45% for the duration of one year (Strelec *et al.*, 2010). After 90 days, the seed stored at 40°C had greater loss, compared to 25°C and 4°C . According to Jelle (2003), seeds can be kept under a varied range of temperatures, provided they are dried to a safe moisture level and that the relative humidity does not increase their moisture during

storage. Therefore, the temperature is not a problem when the relative humidity and moisture are kept low (Mira *et al.*, 2015). A low relative humidity during storage reduces the rate of seed deterioration (Kehinde, 2013). During the night in the modified storage room, the temperatures are low; however, the relative humidity is high, implying that there is a risk of the seed moisture increasing.

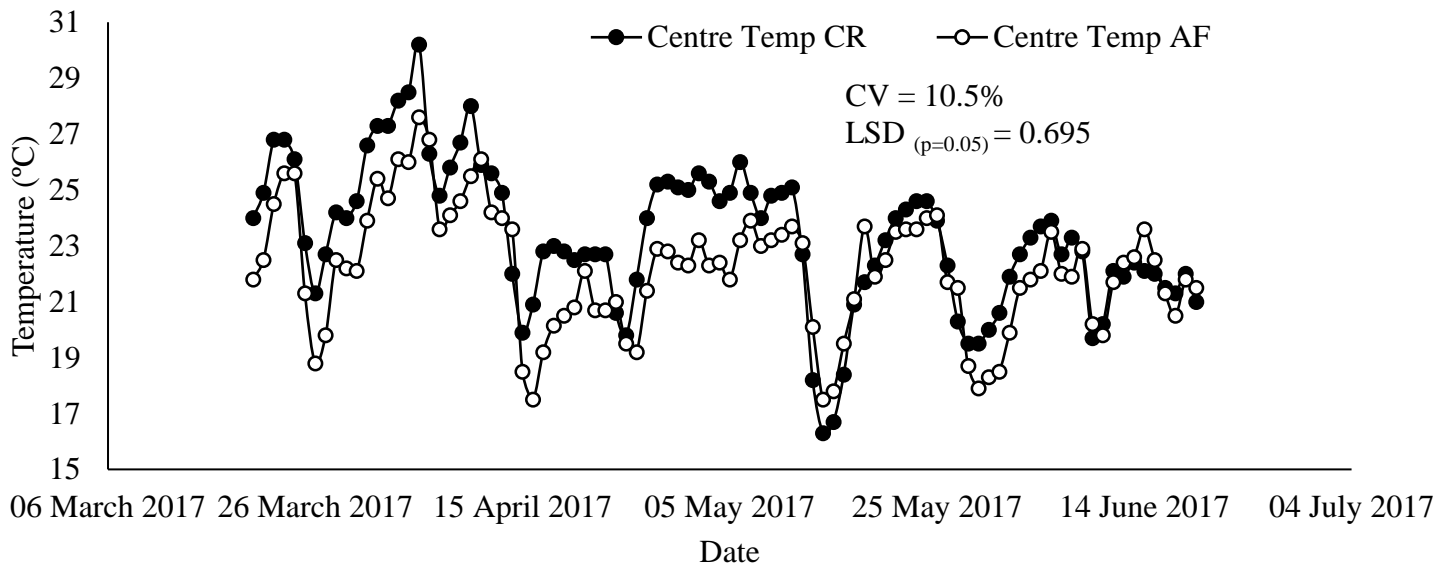

Figure 4.9 Centre temperatures for control room (CR) and modified room (AF) during at night

The relative humidity in the modified storage room at night is higher than the relative humidity during the day. At night, the relative humidity of the ambient air is high and, as a result the relative humidity of the air in the storage room also increases. The average relative humidity in the control and modified storage room is $58.5\% \pm 7.32$ and $63.7\% \pm 6.28$, respectively (see Figure 4.10). The difference between relative humidity in the control and modified storage room is significant ($P \leq 0.05$). Seeds stay longer when they are dried to 11% or less at a temperature of $25 \pm 3^\circ\text{C}$, and a relative humidity of 70-75% (Hettiarachchi *et al.*, 2010), and both storage rooms are in agreement with these results, except for the moisture content which is greater than 11%. The relative humidity in the modified storage room rose from $40.1\% \pm 3.21$ during the day to $63.7\% \pm 6.28$ at night. The increase in the relative humidity in the modified storage room is due to the high relative humidity and ambient air introduced to the structure at night.

In the control storage room, relative humidity decreased from $60.6\% \pm 5.87$ during the day to $58.5\% \pm 7.32$ at night, thus, it can maintain the same relative humidity throughout the day and

night. Hence, the relative humidity achieved by the modified storage room should be maintained throughout the day and night, by closing the structure when the sun sets. It will ensure that air relative humidity does not rise at night as is the case in the control room since it is a closed structure.

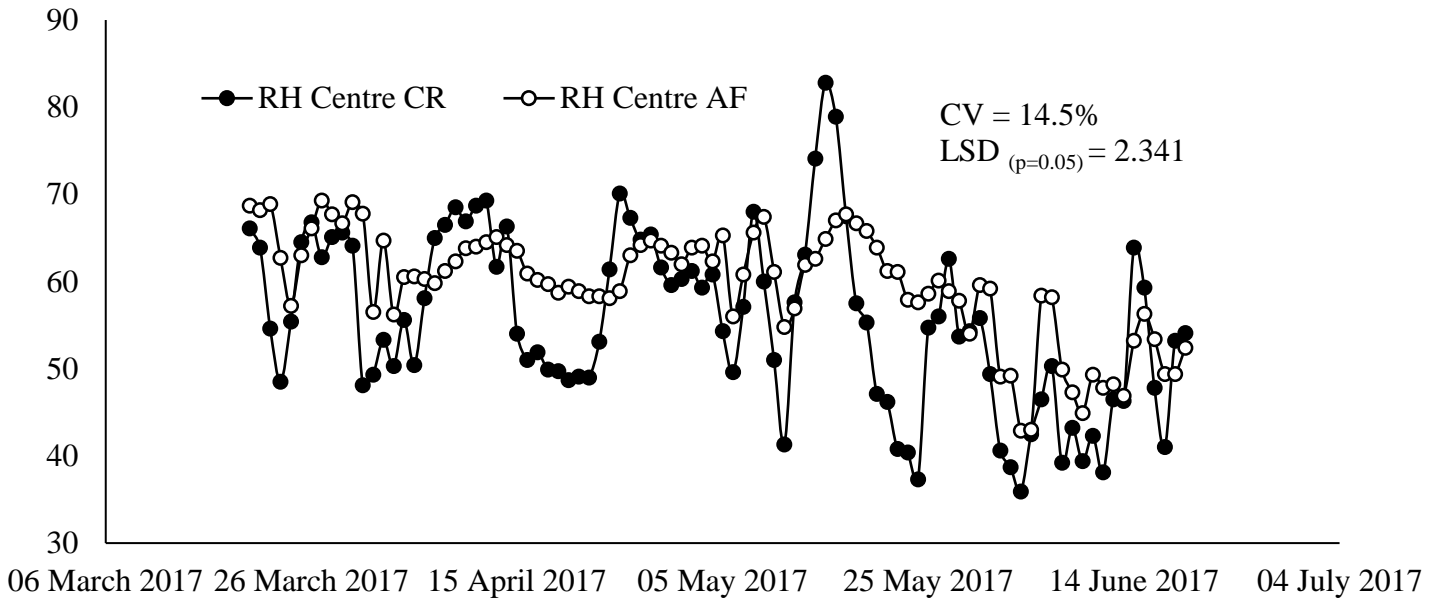

Figure 4.10 Centre air relative humidity for control room (CR) and modified room (AF) during at night

The temperature inside the seeds contained in the bag in the modified storage room dropped below the temperature inside the seed bags in the control storage room during the night (see Figure 4.11). The average temperature in the seeds contained in the bags at night in the control storage room was $22.4^{\circ}\text{C} \pm 5.36$ and in the modified storage room had an average temperature of $20.9^{\circ}\text{C} \pm 4.11$. The temperature in the modified storage room is higher, since heated air is being circulated around in the storage; on the other hand, the control room does not provide any kind of heating. There was a significant difference ($P \leq 0.05$) between the temperature in the seed bags stored in the modified and the control storage rooms. The temperature inside the seed bags in the control room during the day was slightly lower ($21.4^{\circ}\text{C} \pm 4.25$) than the temperature at night ($22.4^{\circ}\text{C} \pm 5.36$). This may be due to the heat released at night and which is gained by the storage room during the sunshine hours of the day, which rises the temperature inside the structure (Walikewitz *et al.*, 2015; Marshall *et al.*, 2016). The opposite occurred in the modified storage room, as the temperature inside the seed bags during the day was higher ($26.7^{\circ}\text{C} \pm 2.70$) than the temperature at night ($20.9^{\circ}\text{C} \pm 4.11$). A decrease in temperature in the

modified storage room at night is due to the mixing of outdoor air which has higher relative humidity than the indoor air with indoor air.

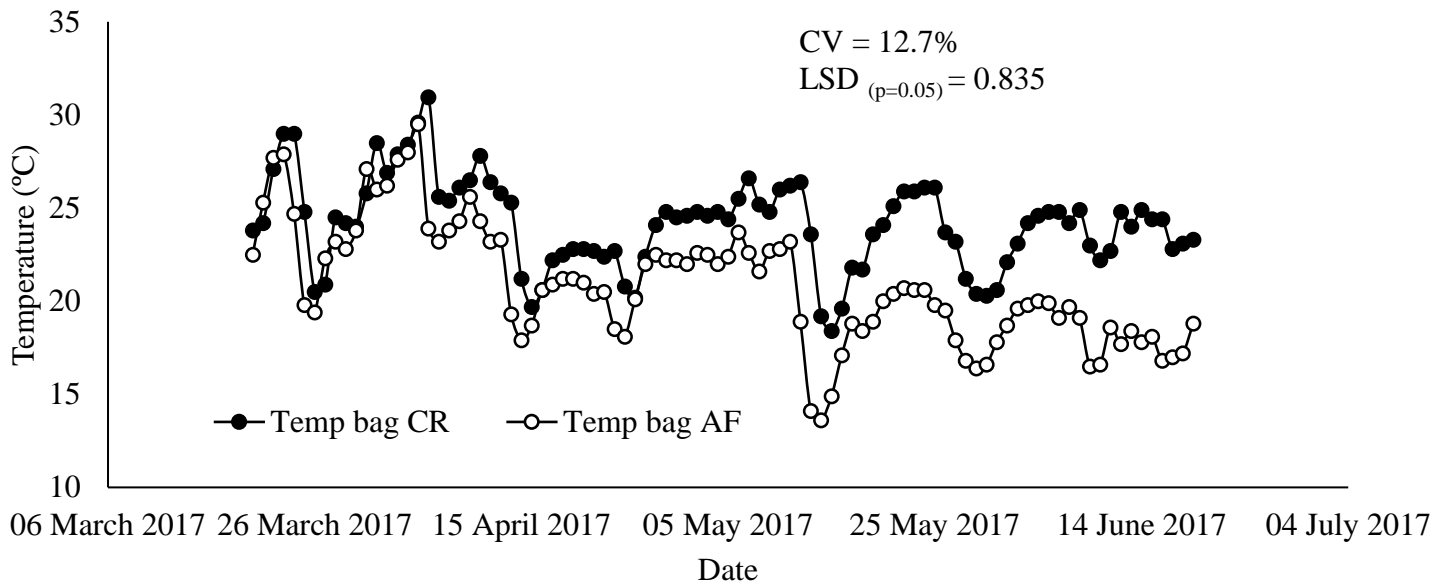

Figure 4.11 Seed bag temperature for control room (CR) and modified room (AF) at night

The relative humidity inside the seed bags stored in the modified storage room ($57\% \pm 6.07$) increased above the relative humidity in the control storage ($52.7\% \pm 8.65$), which is attributed to the high relative humidity air entering the storage at night (see Figure 4.12). The difference between the relative humidity in the control and modified storage rooms was significant ($P \leq 0.05$). The outdoor relative humidity at night is high, and, as a result the indoor relative humidity increases since the storage introduces fresh air from outdoors during its operation. Seed bags in the control room had a higher relative humidity ($66.1\% \pm 7.34$) during the day than at night ($57\% \pm 6.07$). However, the relative humidity inside the seed bag in the modified storage room exhibited different behaviour, as the relative humidity at night was higher ($66.1\% \pm 7.34$) than the relative humidity obtained during the day ($44.4\% \pm 6.11$). The air relative humidity in the modified storage room is high which is attributed to the outdoor air with high relative humidity entering the storage at night there is no solar energy to assist in reducing the relative humidity.

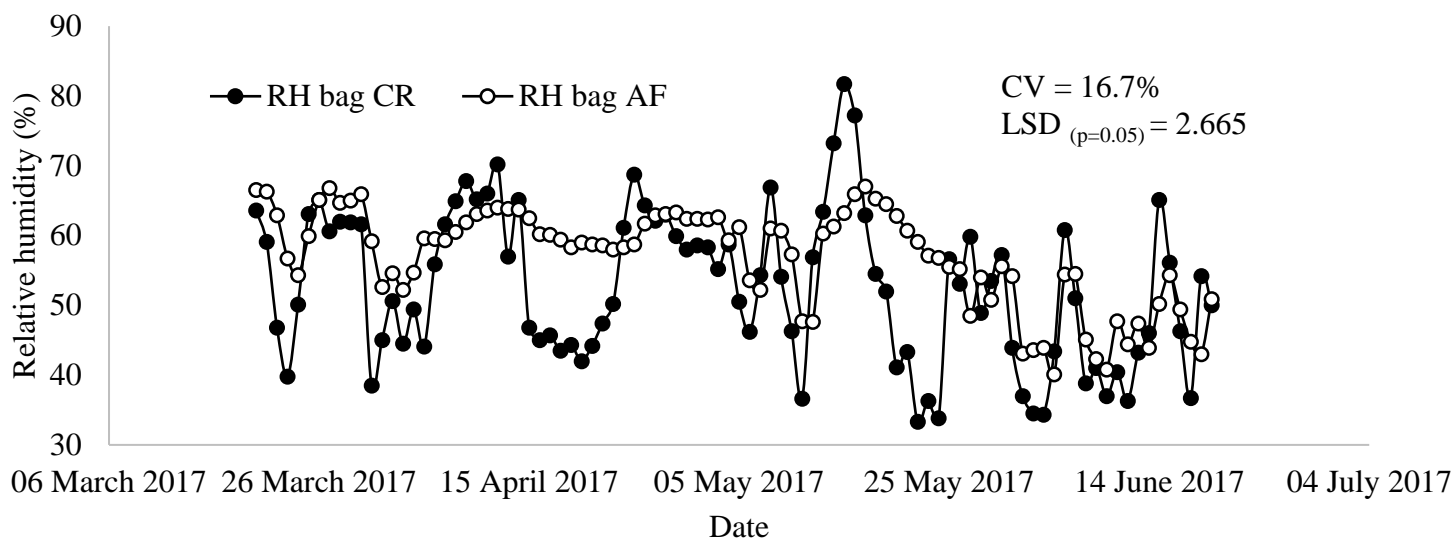

Figure 4.12 Seed bag air relative humidity for control room (CR) and modified room (AF) during at night

4.4.3 Seed moisture content

The seed moisture content decreased from 12.6% to 12.4% over the period of three months during storage. On the other hand, the moisture content of the seeds stored in the control storage room increased from 12.6% to 13.8% during storage (see Figure 4.13). The difference between the moisture content of seeds stored in the modified and control storage rooms was found to be significant ($P \leq 0.05$) (see Table 4.1). The moisture content in the modified storage room decreased due to the lower relative humidity air supplied by the storage in the presence of solar energy, whereas, moisture content in the control storage increased, due to the high relative humidity, since there was no solar collector to reduce the relative humidity. Kehinde (2013) and Dai *et al.*, (2015) also found that the increasing relative humidity increases the moisture content during seed storage and that the high moisture content decreases the seed longevity. Osueke (2013) reported that with a moisture content ranging from 12-13%, seeds are capable of being viable for 8-12 months. Moisture content of less than a 14% wet basis during storage is considered to be safe (Magan and Aldred, 2007; Govender *et al.*, 2008; Weinberg *et al.*, 2008; International Rice Research Institute, 2013; Welch and Delouche, 2016). The moisture content (12-13%) achieved by the storage room over the period of storage is good for enhancing seed shelf-life according to Brownfield and Seeds (2006) and Matthes and Rushing (2016).

Therefore, the seed moisture content achieved in the modified storage room improves the storability of seeds.

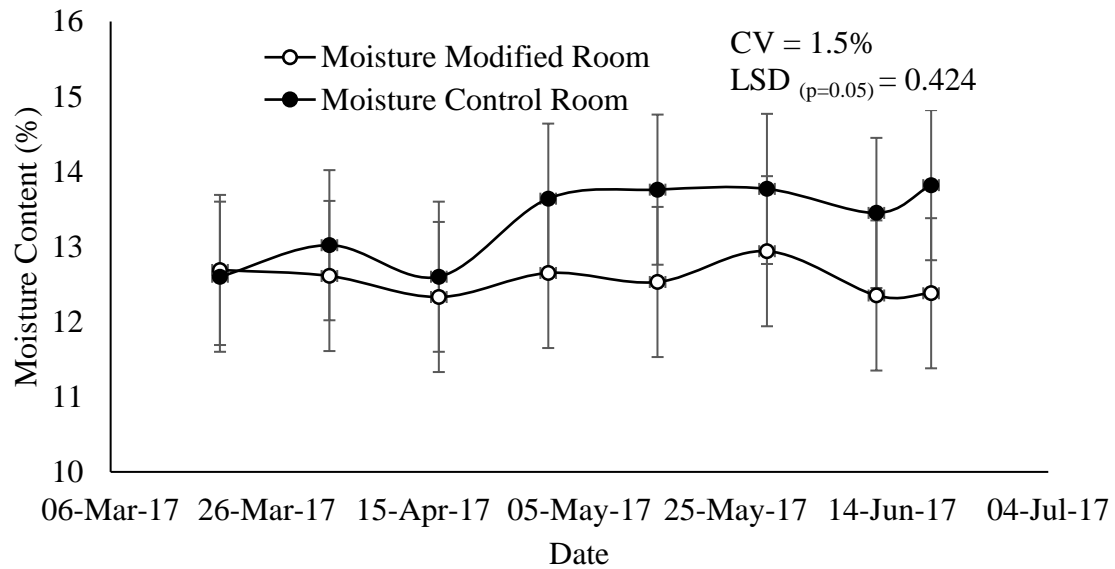

Figure 4.13 Seed moisture content

4.4.4 Seed germination

The Germination rate of the seeds stored in the control storage room decreased faster than the germination rate of the seeds stored in the modified storage room (see Figure 4.14). Control storage germination decreased from 99% to 94%, whereas, germination from the modified storage room decreased from 99% to 97% over the period of three months. Moreover, the difference between the germination percentage of the control and modified storage rooms was significant ($P \leq 0.05$). The germination percentage is influenced by the storage conditions, the high temperature and relative humidity accelerates the deterioration of the stored seeds (Delouche *et al.*, 2016). For the maize that was stored for the period of one year in the general storage room, with no ventilation and where temperatures that were reached were between 35°C and 37°C, germination was reduced drastically from 88.7% to 0.0% (Govender *et al.*, 2008). The germination and vigour of seeds stored at a temperature of 40°C ± 2 and 11%, 32%, 50%, and a relative humidity of 75% were studied for three months by Suma *et al.*, (2013). The results showed that an elevated relative humidity (75%) considerably decreased the quality of the seeds, as the germination rate reduced from 85% to 30% within three months. The relative

humidity obtained from the current study is higher ($66.1\% \pm 7.34$) in the control room than in the modified room ($44.4\% \pm 6.11$), which is the reason why the germination rate in the control room dropped faster than the germination rate in the modified room. Overall, the modified storage room performed better than the control storage room according to, the germination results obtained.

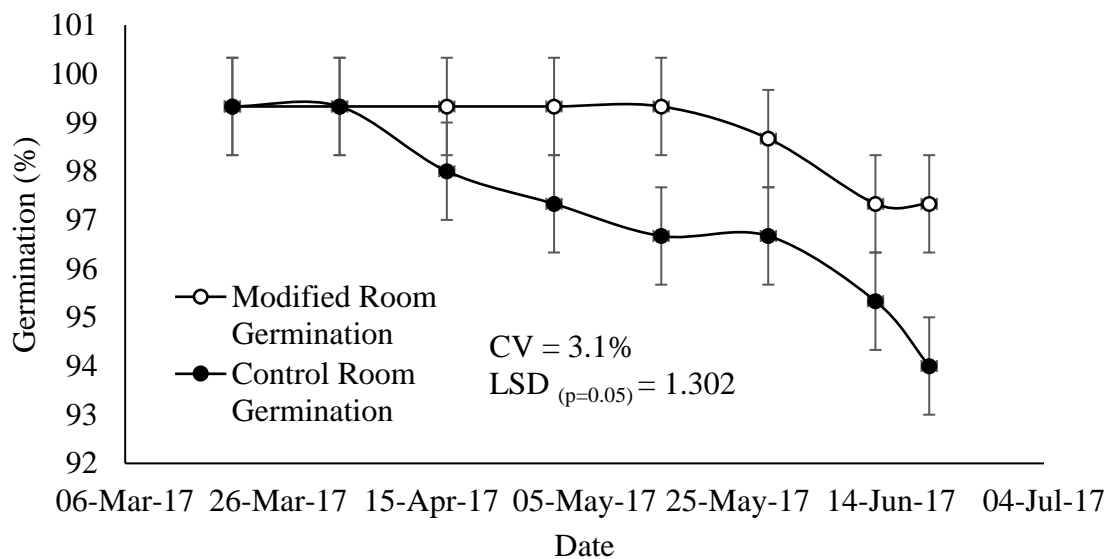

Figure 4.14 Seed germination percentage during the period of storage

4.4.5 Seed vigour

The vigour results are expressed as germination percentages. After accelerated ageing, the seed vigour of the modified storage room decreased from 94% to 93%, while that of the control storage room decreased drastically from 95% to 88% over a period of three months (see Figure 4.15). There was a significant difference ($P \leq 0.05$) between the seed vigour obtained from both storages room. A seed vigour of 80% or greater is considered to be good according to, Society Commercial Seed Technologists (2016). The difference between germination and vigour should be 15%, at most (iGrow Corn, 2016). Which is in agreement with the results of seed vigour. In addition, if the seed vigour percentage is close to that of germination, it is an indication of the good vigour (Seed Check, 2017). Both storage rooms were successful in preserving vigour over the storage period; however, the control storage lost vigour quicker than the modified storage room, which was due to the different conditions provided by different storage rooms.

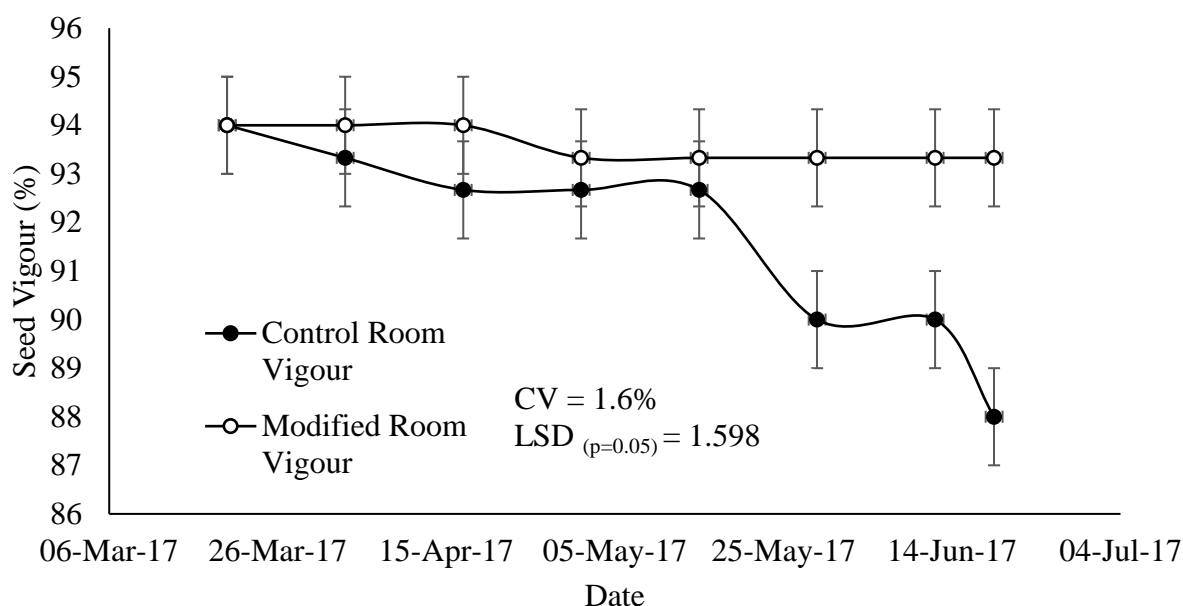

Figure 4.15 Seed vigour

4.5 Conclusions

A Significantly lower ($P \leq 0.05$) relative humidity (40.1%) was achieved during the day, as was expected, due to the availability of solar energy, compared to that in the control storage room. At night, a high relative was dominant, especially in the modified storage room (63.7%) Therefore, to ensure that a low relative humidity is achievable, a modified storage room should only be open during the day and closed at night. When it is open during the day, the hot air in the roof solar collector is utilised to reduce the relative humidity in the storage environment, and when closed at night, the ambient air, with high relative humidity is avoided.

An increase in the seed moisture content is dependent on the environmental conditions during storage. The moisture content decreased from 12.6% to 12.4% in the modified storage room, whereas it increased in the control storage room from 12.6% to 13.8%. Therefore, the modified storage room is good, in terms of keeping the seed moisture content low <14% during storage, since a low moisture content lowers the risk of spoilage.

The average germination percentages were, $96.8\% \pm 1.49$ and $98.5\% \pm 0.85$, for the control and modified storage rooms, respectively, after three months of storage, decreasing from 99%. The obtained germination percentages indicate good storability. The germination percentage decreased faster in the control room than in the modified room, and similarly, the seed vigour declined from 95% to 88% in the control storage room, whereas in the developed storage room

the vigour declined from 94% to 93%. Thus, the developed storage room performed better than the control storage room and was able to preserve the seed quality during storage.

4.6 References

- Adejumo, BA and Raji, AO. 2007. Technical appraisal of grain storage systems in the Nigerian Sudan Savanna. *The CIGR Journal* 11(2007):1-11.
- Brownfield, P and Seeds, S. 2006. The Effects of Storage Conditions on Seed Shelf Life. [Internet]. Rogers, Rogers, USA. Available from: <https://www.seedquest.com/id/r/rogers/pdf/seedstorage.pdf>. [Accessed: 10 July 2017].
- Chiu, K, Chen, C and Sung, J. 2002. Effect of priming temperature on storability of primed sweet corn seed. *Crop Science* 42(6):1996-2003.
- Coasta, DM, Machado, LC, Bittencourt, F and Pereira, LC. 2013. Quality of maize for commercially available animal nutrition and methods for determining moisture. *Agrogeoambiental Magazine* 5(2):25-34.
- Coradi, PC, Camilo, LJ, Cunha, FF, Pereira, TLL and Alves, CZ. 2016. Alternatives of storage of corn grains for the conditions of the Brazilian Cerrado. *Bioscience Journal* 32(1):29-40.
- Dai, J-W, Rao, J-Q, Wang, D, Xie, L, Xiao, H-W, Liu, Y-H and Gao, Z-J. 2015. Process-based drying temperature and humidity integration control enhances drying kinetics of apricot halves. *Drying Technology* 33(3):365-376.
- Delouche, JC, Matthes, RK, Dougherty, GM and Boyd, AH. 2016. Storage of seed in sub-tropical and tropical regions. *Seed Science and Technology* 1(2016):671-700.
- Gonzales, HB, Armstrong, PR and Maghirang, RG. 2009. Simultaneous monitoring of stored grain with relative humidity, and carbon dioxide sensors. *Applied Engineering in Agriculture* 25(4):595-604.
- Govender, V, Aveling, TAS and Kritzing, Q. 2008. The effect of traditional storage methods on germination and vigour of maize (*Zea mays* L.) from northern KwaZulu-Natal and southern Mozambique. *South African Journal of Botany* 74(2):190-196.
- Hettiarachchi, GHCM, Goonaratne, J and Hirimburegama, WK. 2010. Effect of initial moisture content and relative humidity on the accumulation of aflatoxin in maize grains (*Zea Mays*) during storage. *Journal of the National Science Foundation of Sri Lanka* 29(2010):29-34.

- Horwitz, W, Chichilo, P and Reynolds, H. 1970. *Official Methods of Analysis of the Association of Official Analytical Chemists*. Association of Official Analytical Chemists, Washington, DC, USA.
- iGrow Corn. 2016. Corn Seed Testing. [Internet]. iGrow Corn, Brookings, USA. Available from: <https://igrow.org/up/resources/03-5000-2016-06.pdf>. [Accessed: 28 June 2017].
- International Rice Research Institute. 2013. Seed Quality. [Internet]. International Rice Research Institute, Los Baños, Philippines. Available from: <http://www.knowledgebank.irri.org/step-by-step-production/postharvest/storage/grain-storage-systems>. [Accessed: 04 June 2016].
- Janmohammadi, M, Dezfuli, PM and Sharifzadeh, F. 2008. Seed invigoration techniques to improve germination and early growth of inbred line of maize under salinity and drought stress. *Gen. Appl. Plant Physiol* 34(3-4):215-226.
- Jayas, DS and White, NDG. 2003. Storage and drying of grain in Canada: low cost approaches. *Food Control* 14(4):255-261.
- Jelle, H. 2003. *The Storage of Tropical Agricultural Products*. Report No. 835. Agromisa Foundation, Wageningen, the Netherlands.
- Jian, F and Jayas, DS. 2012. The ecosystem approach to grain storage. *Agricultural Research* 1(2):148-156.
- Jian, F, Chelladurai, V, Jayas, DS and White, ND. 2015. Three-Dimensional Transient Heat, Mass, and Momentum Transfer Model to Predict Conditions of Canola Stored inside Silo Bags under Canadian Prairie Conditions: Part II. Model of Canola Bulk Temperature and Moisture Content. *Transactions of the ASABE* 58(4):1135-1144.
- Joao Abba, E and Lovato, A. 1999. Effect of seed storage temperature and relative humidity on maize (*Zea mays* L.) seed viability and vigour. *Seed Science and Technology* 27(1):101-114.
- Kehinde, OO. 2013. *Longevity of Maize Seeds under Controlled and Open storage System*. Babcock University, Ilishan Remo, Nigeria.
- Lawrence, J and Maier, DE. 2010. Aeration strategy simulation for wheat storage in the sub-tropical region of north India. *Transactions of the ASABE* 54(4):1395-1405.
- Lee, S-S, Yun, S-H, Yang, S-K and Hong, S-B. 2006. Changes in seed vigour of sweet and super sweet corn hybrids as affected by storage conditions. *Korean Journal of Crop Science* 51(5):432-439.
- Magan, N and Aldred, D. 2007. Post-harvest control strategies: minimizing mycotoxins in the food chain. *International Journal of Food Microbiology* 119(1):131-139.

- Mallory, JK. 2015. Abnormal waves on the south east coast of South Africa. *The International Hydrographic Review* 51(2):1-13.
- Marshall, E, Steinberger, JK, Dupont, V and Foxon, TJ. 2016. Combining energy efficiency measure approaches and occupancy patterns in building modelling in the UK residential context. *Energy and Buildings* 111(2016):98-108.
- Martin, DT, Baributsa, D, Huesing, JE, Williams, SB and Murdock, LL. 2015. PICS bags protect wheat grain, *Triticum aestivum* (L.), against rice weevil, *Sitophilus oryzae* (L.)(Coleoptera: Curculionidae). *Journal of Stored Products Research* 63(2015):22-30.
- Matthes, K and Rushing, KW. 2016. Seed drying and conditioning. *Seed Technology* 4(7):256-264.
- Matthes, RK, Dougherty, GM, Delouche, JC and Boyd, AH. 2016. Drying, processing and storage of corn seed in tropical and sub-tropical regions. *Seed Storage* 1(2016):1-15.
- Mira, S, Estrelles, E and González-Benito, ME. 2015. Effect of water content and temperature on seed longevity of seven Brassicaceae species after 5 years of storage. *Plant Biology* 17(1):153-162.
- Moreno-Martinez, E, Vazquez-Badillo, M, Rivera, A, Navarrete, R and Esquivel-Villagrana, F. 1998. Effect of seed shape and size on germination of corn (*Zea mays* L.) stored under adverse conditions. *Seed science and technology* 26(2):439-448.
- Nagel, M and Börner, A. 2010. The longevity of crop seeds stored under ambient conditions. *Seed Science Research* 20(1):1-12.
- Osueke, OC. 2013. Design modelling of a fluidized bed for grain drying. *Journal of Engineering Research and Development* 7(9):10-15.
- Rao, NK, Dulloo, ME and Engels, JMM. 2017. A review of factors that influence the production of quality seed for long-term conservation in genebanks. *Genetic Resources and Crop Evolution* 64(5):1061-1074.
- Roberts, E. 1972. Storage environment and the control of viability. *Viability of Seeds* 1(1972):14-58.
- Seed Check. 2017. Accelerated Ageing Vigour Test. [Internet]. Seed Check, Leduc, Canada. Available from: <http://www.seedcheck.net/seed-check-tests/vigour/accelerated-ageing-vigour-test/>. [Accessed: 29 June 2017].
- Sharon, M, Abirami, C and Alagusundaram, K. 2014. Grain storage management in India. *Journal of Post-Harvest Technology* 2(1):12-24.

- Šimić, B, Sudarić, A, Liović, I, Kalinović, I, Rozman, V and Ćosić, J. 2006. *Influence of storage conditions on seed quality of maize, soybean, and sunflower*. Report No. PS1-7-6121. The Agricultural Institute Osijek, Osijek, Croatia.
- Society Commercial Seed Technologists. 2016. Seed Testing. [Internet]. Society Commercial Seed Technologists, Washington, DC, USA. Available from: <http://www.michcrop.com/seedtesting.asp>. [Accessed: 29 June 2017].
- Somavat, P, Huang, H, Kumar, S, Garg, MK, Danao, M-GC, Singh, V, Paulsen, MR and Rausch, KD. 2017. Comparison of hermetic storage of wheat with traditional storage methods in India. *Applied Engineering in Agriculture* 33(1):121-130.
- Soponronnarit, S. 2017. Energy model of grain drying system. *ASEAN Journal on Science and Technology for Development* 5(2):43-68.
- Strelec, I, Popovic, R, Ivanisic, I, Jurkovic, V, Jurkovic, Z, Ugarcic-Hardi, Z and Sabo, M. 2010. Influence of temperature and relative humidity on grain moisture, germination and vigour of three wheat cultivars during one year storage. *Poljoprivreda* 16(2010):20-24.
- Suleiman, RA, Rosentrater, KA and Bern, CJ. 2013. *Effects of deterioration parameters on storage of maize*. Report No. 9. Iowa State University, Ames, USA.
- Suma, A, Sreenivasan, K, Singh, AK and Radhamani, J. 2013. Role of relative humidity in processing and storage of seeds and assessment of variability in storage behaviour in Brassica spp. and Eruca sativa. *The Scientific World Journal* 1(2013):1-9.
- Tefera, T. 2012. Post-harvest losses in African maize in the face of increasing food shortage. *Food Security* 4(2):267-277.
- Walikewitz, N, Jänicke, B, Langner, M, Meier, F and Endlicher, W. 2015. The difference between the mean radiant temperature and the air temperature within indoor environments: A case study during summer conditions. *Building and Environment* 84(2015):151-161.
- Wang, N. 2015. *Impact of low-temperature storage on quality of high-moisture corn grain*. Report No. 5. University of Illinois, Normal, USA.
- Weinberg, ZG, Yan, Y, Chen, Y, Finkelman, S, Ashbell, G and Navarro, Y. 2008. The effect of moisture level on high-moisture maize (*Zea mays* L.) under hermetic storage conditions—in vitro studies. *Journal of Stored Products Research* 44(2008):136-144.
- Welch, GB and Delouche, JC. 2016. Seed processing and storage facilities for tropical areas. *Seed Science* 3(5):1-12.

- White, SD, Murphy, PT, Bern, CJ and van Leeuwen, JH. 2010. Controlling deterioration of high-moisture maize with ozone treatment. *Journal of Stored Products Research* 46(1):7-12.
- Woltz, J and TeKrony, D. 2001. Accelerated aging test for corn seed. *Seed Technology* 23(2001):21-34.

5. CONCLUSION AND RECOMMENDATIONS

5.1 Conclusions

The literature consulted in this study revealed that most sub-Saharan African countries do not have proper storage facilities for storing seeds. For instance, for traditional seed storage facilities in Nigeria, the seed value and economic losses were found to be in the range of 10% and 20% in the first six months of storage. Furthermore, proper storage facilities are expensive to install, operate and maintain, since they use mechanical compression refrigeration systems. Therefore, the first objective of this study was to develop a naturally-ventilated seed storage room that will solve the current problem of poor environmental conditions encountered in the traditional storage systems in Africa. In addition, the seed storage room should utilise renewable energy, and mainly solar energy to reduce the costs associated with storing seeds. The last objective was to develop a seed storage facility that would be effective in preserving the quality of maize seeds stored over a period of three months. The following conclusions were made:

- (a) Different chimney sizes were evaluated, to determine the optimal chimney size to be used in the storage room. A 300 mm x 4.8 m chimney size achieved the highest ventilation rate of $0.675 \text{ km}\cdot\text{hr}^{-1}$, which corresponds to the air change per hour of 17.4 ACH. On the other hand, a 200 mm x 3.6 m chimney size achieved $0.1 \text{ km}\cdot\text{hr}^{-1}$, which is the lowest ventilation rate when compared to all the other chimney sizes used. The difference between the ventilation rates of the respective chimney sizes was significant ($P \leq 0.05$). It was concluded that the larger the diameter, the more ventilation rate improves; similarly, the longer the chimney, the more ventilation rate increases in the storage room. Therefore, a naturally-ventilated seed storage room was developed by using a 300 mm x 4800 mm chimney for circulating hot air from the roof solar collector.
- (b) A control room was used as a basis for comparing the performance of the developed storage room, concerning its effectiveness in preserving seed vigour and germination during storage. The germination percentage decreased by 5% in the control room, whereas there was a decrease of 2%, from the initial germination of 99%. Furthermore, the difference between the germination percentages in both the modified and control rooms was significant ($P \leq 0.05$). The seed vigour decreased from 94% to 93% in the developed storage room; on

the other hand, the vigour decreased from 95% to 88% in the control room. There was a significant difference ($P \leq 0.05$) between the seed vigour obtained in the developed storage room and the control room. The seed moisture content in the developed storage room was significantly ($P \leq 0.05$) lower (12.4%) than the moisture content in the control room (13.8%), after three months of storage. The developed seed storage room was found to preserve the seed quality for the period over which it was tested.

5.2 Recommendations

From this study, the following recommendations were made:

- (a) The chimney sizes can be increased beyond the largest size used (300 mm x 4.8 m), to determine the optimum size for the storage system developed, by using the Computational Fluid Dynamic (CFD) models. The Chinese cap and the Whirly bird can be used to improve the ventilation rate, temperature and relative humidity distribution in the storage room.
- (b) In the modified storage room, the relative humidity at night was found to always increase; hence, it is recommended that the storage system should be closed at this time of the day, that is, to block the outdoor air from entering the storage facility. Moreover, the storage period can be extended beyond three months, to determine the time it takes for the stored seeds to die in this type of storage system.