



# Journal of Solar Energy Research (JSER)

Journal homepage: [www.jser.ut.ac.ir](http://www.jser.ut.ac.ir)



## An Overview of Solar Thermal Power Generation Systems

F. Jalili Jamshidian<sup>a</sup>, Sh. Gorjian<sup>b\*</sup>, M. Shafiee Far<sup>a</sup>

<sup>a</sup> Water Resources Management and Engineering Department, Tarbiat Modares University (T.M.U.), Jalaal-Ahmad Highway, Tehran, Iran.

<sup>b</sup> Biosystems Engineering Department, Tarbiat Modares University (T.M.U.), Jalaal-Ahmad Highway, Tehran, Iran; \*Email: [Gorjian@modares.ac.ir](mailto:Gorjian@modares.ac.ir)

### ARTICLE INFO

Received: 23 Sept 2018  
Received in revised form:  
29 Oct 2018  
Accepted: 05 Dec 2018  
Available online: 15 Dec  
2018

### Keywords:

Solar Power;  
Greenhouse gases;  
Concentrators;  
TES Systems;  
Heat Transfer Fluid.

### ABSTRACT

In the world today, fossil fuels as conventional energy sources have a crucial role in energy supply since they are substantial drivers of the “Industrial Revolution”, as well as the technical, social, and economic developments. Global population growth along with high levels of prosperity have resulted in a significant increase in fossil fuels consumption. However, fossil fuels have destructive impacts on the environment, being the major source of the local air pollution and emitter of greenhouse gases (GHGs). To address this issue, using renewable energy sources especially solar energy as an abundant and clean source of energy, has been attracted considerable global attention, which can provide a large portion of electricity demand. To make the most of solar energy, concentrated solar power (CSP) systems integrated with cost effective thermal energy storage (TES) systems are among the best options. A TES system has the ability to store the thermal energy during sunshine hours and release it during the periods with weak or no solar radiation. Thus, it can increase the working hours as well as the reliability of a solar system. In this paper, the main components of the solar thermal power systems including solar collectors, concentrators, TES systems and different types of heat transfer fluids (HTFs) used in solar farms have been discussed.

© 2018 Published by University of Tehran Press. All rights reserved.

### 1. Introduction

The growing global energy demand from burning fossil fuels is the main reason for the upward trend in greenhouse gas (GHG) emissions and distribution of air pollutants. Rapid population growth and increasing energy demand, especially in the developing countries have created several concerns include poverty, air pollution, health hazardous, and environmental problems. In Iran, the increase in CO<sub>2</sub> emissions has placed the country among the ten largest GHG emitters in the world and also the top contributor to CO<sub>2</sub> emission in the Middle East [1]. Therefore, seeking alternative energy sources and the efficient use of them could be a sustainable solution to this problem. Renewable energies are alternative energy resources which are virtually inexhaustible since they are produced because of being available in huge quantities or being able by natural

energies are as follows; solar, wind, biomass, geothermal, hydropower, tidal, wave and ocean [2].

Solar energy is an abundant renewable energy source, which can provide energy with high values of security for all. This energy source is freely available in many regions around the world especially the Middle East and North Africa (Fig. 1).

Solar energy represents the most promising and viable form of renewable energy for power generation today and in the future [3]. Solar energy is radiant light and heat from the sun, which can be harnessed and then converted into two common forms of electric power and thermal power. Totally, solar power generation technologies are divided into two main categories of photovoltaic (PV) systems and concentrating solar power (CSP) systems. The first one converts directly the solar

radiation into electricity by using solar PV cells while, the second technology can produce electricity by using concentrators (mirrors or

lenses) (Fig. 2) which concentrate the solar radiation into the values to reach high temperatures commonly between 400°C and 1000°C [1].



Figure 1. Global map of solar radiation

.In concentrating solar thermal technologies (CST), solar energy is converted into heat for domestic and/or commercial applications such as drying, air and water heating, cooling, cooking, etc. While CSP technologies are being used to generate electricity. The latter involves the use of high-concentration mirrors to concentrate solar energy and convert it into heat and then electricity by using a turbine [4].



Figure. 2. Solar mirrors (upper) and solar lenses (lower) which both concentrate solar radiation.

A heat transfer fluid (HTF) passes through various components of a solar field in a cycle to provide the required heat or electricity in a secondary application. The HTF is pumped to solar collectors and its temperature rises significantly

when absorbs sufficient thermal energy (if solar radiation is enough). Then, it may be used directly for another application (in the form of liquid or vapor) or transferred into another working fluid by using a heat exchanger (HE) [5]. In many applications, this heat can run a steam or Organic Rankine Cycle (ORC) to produce both heat and electricity. Thereafter, the heat content of the HTF is released and returned to the solar collectors to start another loop. To enhance the efficiency and reliability of the solar system, it is suggested to use a thermal energy storage (TES) system in different ways when the solar radiation exceeds the demand. Then the TES system could be discharged in the absence or deficiency of solar radiation and therefore, the duration of working hours of the system will be increased.

In this paper, the main components of a solar thermal power generation system include solar collectors, concentrators, TES system, the HTF and the pumping system will be described. In addition, the various applications and also the pros and cons of these systems will be presented.

## 2. Solar Thermal Collectors

The main component of a typical solar thermal system is the solar collector. Working principle of solar thermal collectors is similar to heat exchangers where solar radiation is converted into the internal energy of the HTF. A solar collector absorbs the incoming solar radiation, converts it into heat, and transfers this generated heat into a fluid (usually air, water, oil, etc.) flowing through

the collector. Therefore, collected solar thermal energy is transferred from the working fluid either directly to the hot water or space conditioning systems, or to a thermal energy storage tank which can be used later at night or during the cloudy days [6].

There are two types of solar collectors: non-concentrating or stationary collectors and concentrating ones. A non-concentrating collector has the same area for intercepting and absorbing solar radiation, whereas a sun-tracking concentrating solar collector usually has parabolic reflecting surfaces to intercept and focus the sun's beam radiation to a smaller receiving area, which is called the absorber. Therefore, the radiation flux will be increased. In contrast, stationary collectors are fixed in position and do not track the sun. They are often classified into three types of flat plate collectors (FPC), evacuated tube collectors (ETC) and, compound parabolic collectors (CPC). On the other hand, concentrated collectors track the sun and only are able to capture direct solar radiation either onto a point such as parabolic dish concentrator (PDC) and solar towers or onto a linear receiver such as parabolic trough concentrator (PTC) and linear Fresnel reflectors (LFR) [3].

Table 1. Different types of solar collectors [3, 6].

Motion	Collector type	Absorber type	Temp. (°C)	Category
Stationary	FPC	Flat	30-100	Low
	ETC	Flat	90-200	Low
	CPC	Tubular	70-240	Low
One-axis tracking	PTC	Tubular	70-400	Low-medium
	LFR	Tubular	100-400	Low-medium
Two-axis tracking	PDR	Point	500-1200	High

As explained above, according to the solar collector type, the transport medium or HTF can be heated to low-, medium- or high-temperature ranges. According to a classification, low-temperature solar collectors can heat up to 240 °C, medium-temperature can reach to the temperatures between 240 °C and 400 °C, and high-temperature ones can produce temperatures above 400 °C. Table 1 shows different types of commonly used

solar collectors based on the technology type, temperature ranges and the corresponding category regarding the temperature values.

## 2.1. Stationary Solar Collectors

### 2.1.1. Flat Plate Collectors (FPC)

FPCs are simple types of solar collectors which are made of fluid tubes (mainly filled with flowing HTF) connected to a commonly black surface with high absorptivity which is able to collect both direct and diffuse solar radiation and transfer the heat to the tubes. To reduce both convection and radiation heat losses, a transparent cover protects the absorber. While conduction losses are limited with an efficient thermal insulation casing. This technology is well-suited for low-temperature applications like hot water and can achieve acceptable thermal efficiencies due to limited heat losses [7]. Fig. 3 shows a schematic view of FPC.

### 2.1.2. Evacuated Tube Collectors (ETC)

ETCs use liquid-vapor phase change materials (PCMs) to transfer heat at a high efficiency. These collectors include a heat pipe which is a highly efficient thermal conductor placed inside a vacuum-sealed tube. The pipe has been attached to a black copper fin that fills the tube. Top of each tube has a metal tip attached to the sealed pipe. The heat pipe contains a small amount of fluid that undergoes an evaporating-condensing cycle. During this cycle, solar heat evaporates the liquid, and the vapor travels to the heat sink region where it condenses and releases its latent heat. The condensed fluid turns back to the heat pipe and the process will be continued (Fig. 4). HTF flows through the manifold and picks up the heat from the tubes. The heated liquid circulates through another heat exchanger and gives off its heat to a process which can then be stored in a solar storage tank [6].

### 2.1.3. Compound parabolic collectors (CPC)

A CPC is a low focus concentrator, designed according to the principle of optics. The receiver can collect the sunlight in a certain range of the incident angle of the incident ray so that it can receive both DNI and diffuse radiation [8]. The geometry is a combination of two symmetric parabolic segments with different focal lengths. This arrangement enables the collection of any solar radiation entering the collector within an acceptance angle ranging from 10° to 80° onto the tubal receiver by multiple internal reflections. This important feature allows CPCs to operate without tracker and to extract both direct and some portions of diffuse sunlight.

CPCs are characterized by low concentration ratios of less than 5 and are well-suited for low-temperature applications (up to 240 °C) (Fig. 5) [7].

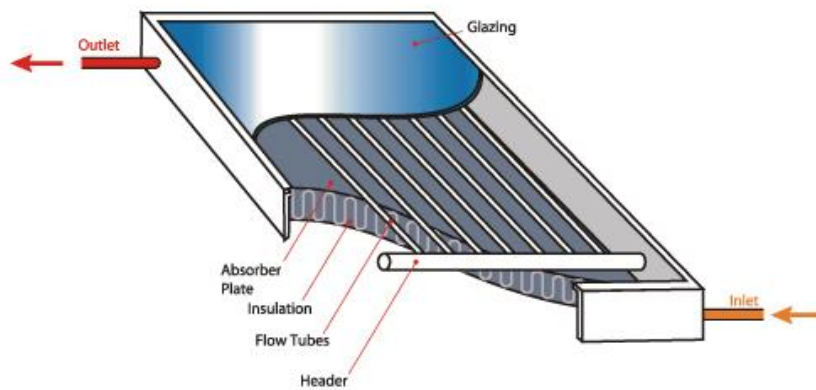

Figure 3. Schematic view of an FPC [6].

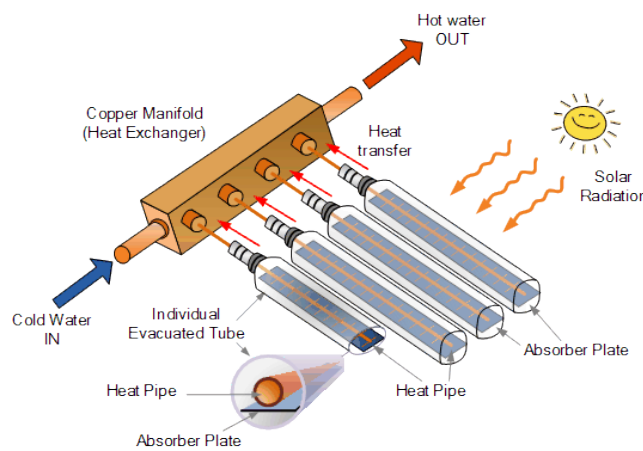

Figure 4. Schematic view of a typical ETC.

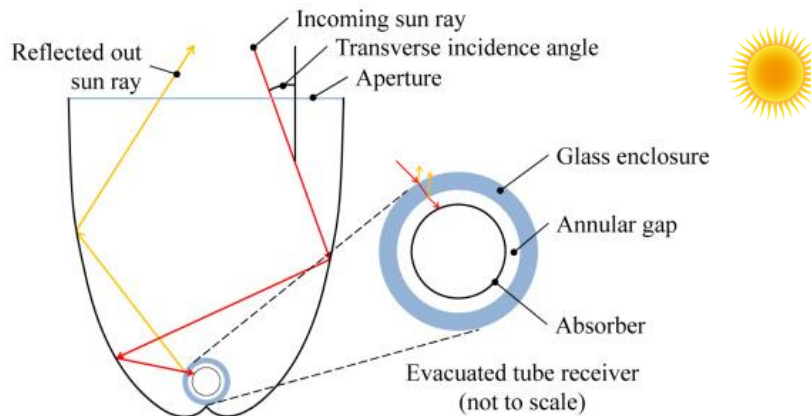

Figure 5. Schematic diagram of a CPC

## 2.2. Concentrating Solar Collectors

### 2.2.1. Parabolic Trough Concentrators (PTCs)

A parabolic trough collector (PTC) is usually made by bending a sheet of reflective material into a parabolic shape. A metal black pipe, covered with a glass tube to reduce heat losses, is located along the focal line of the collector. When the collector is

pointed towards the sun, the parallel beams incident on the surface of the reflector are concentrated onto a receiver tube. The concentrated radiation reaching the receiver tube heats the fluid circulating through it and transforms solar radiation into heat. It is sufficient to use a single-axis tracker. The total lengths of the PTCs receivers are usually

ranged from 25 m to 150 m. The collector can be orientated in an east-west direction, tracking the sun from north to south, or orientated in a north-south direction, tracking the sun from east to west [9].

PTC-based technology is the most advanced of the solar thermal technologies because of considerable experience with the systems and the development of a commercial industry. Also, PTCs are the most mature solar technology to generate heat at temperatures up to 400°C for electricity generation or heat applications. The biggest application of this type of system is the Southern California power plants, known as “Solar Electric Generating Systems” (SEGS), which have a total installed capacity of 354 MWe (Fig. 6) [9].



Figure 6. A PTC-based solar thermal power plant in the U.S. [9].

### 2.2.2. Linear Fresnel Reflectors (LFRs)

LFR technology is based on an array of linear mirror strips which concentrate light on to a fixed receiver mounted on a linear tower. The difference between LFR and PTC is that LFR does not have to be of a parabolic shape and the absorber does not have to move (Fig. 7). The greatest advantage of this type of system is that it uses flat or curved reflectors which are cheaper compared to parabolic glass reflectors.



Figure 7. Schematic view of a typical LFR power system.

Moreover, these reflectors are mounted close to the ground, and therefore, minimizing structural requirements [6]. The LFR has some other

advantages such as less sensitivity to wind, lightweight reflector, low land use, having the gaps to reduce shading/blocking effects and flexible choice of heat transfer fluid [10].

### 2.2.3. Parabolic Dish Reflector (PDR)

A PDR is a point-focus system with a paraboloid geometry given by the revolution of one half of a parabola around its normal axis. Solar radiation entering the collector with a normal incidence is concentrated onto a receiver located at the focal point of the dish (Fig. 8). Parabolic dishes exploit only direct radiation and require a two-axis tracking mechanism to ensure a proper focus throughout the day. Typical concentration ratios of PDRs range from 500 to 3000, making this technology suitable for high-temperature applications up to 1200 °C [7].

At the receiver, the radiative energy is converted to thermal or chemical energy in a heat transfer fluid. The HTF may be the working fluid in a power cycle located at the receiver, (such as for a Stirling engine), or it may be used to transfer energy to the ground for a centralized power cycle. The HTF may also be used to charge a thermal energy storage (TES) system or for industrial processes. Alternatively, receivers may be designed to operate as chemical reactors, with the products of the reaction used for thermochemical processes such as chemical energy storage or production of synthetic fuels [11].



Figure 8. Schematic view of a PDR-based power system.

### 2.3. Solar Collectors Arrangement

There are four basic types of arrangements in which a network of solar collectors can operate. These are series, cascade, pure parallel and series-parallel (Fig. 9). The cascade arrangement works in a similar manner as the parallel arrangement. The only difference is that in the cascade arrangement the distribution headers for the inlet and outlet flow form part of the collector body. The cascade and the parallel arrangements exhibit the same thermo-hydraulic performance. In connection to the case between series-parallel combinations arrangements, it depends on the water flow rate to be handled and the heat load to be delivered.

Generally, in a series arrangement low flow rates can be easily handled while parallel branches are added as the flow rate increases. As higher heat load or delivery temperature are needed, the number of collectors must be increased, particularly the number of units in series per parallel branch [12].

### 3. Heat Transfer Fluid (HTF)

TF is one of the most important components for overall performance and efficiency of the CSP systems. Since a large amount of HTF is required to operate a CSP plant, it is necessary to minimize the cost of HTF but, maximizing the performance. Besides, HTF can be stored in an insulated tank for power generation when sunlight is not available. Fig. 10 provides a comprehensive list of operating temperatures of various HTFs.

Desired properties of an HTF are the low melting point, high boiling point, and thermal stability, low vapor pressure (<1 atm) at high temperature, low corrosive property, low viscosity, high thermal conductivity, high heat capacity for energy storage, and low cost [5, 13]. Based on the type of the material, the HTFs can be classified into five main groups of; (1) air and other gases, (2) water/steam, (3) thermal oils, (4) molten-salts and (5) liquid metals [13, 14]. As can be seen in Fig. 10, the operating temperature range for organics and thermal oils are 12-393 and (-20)-400°C, respectively. Molten-salts have been the most widely studied HTF due to their high operating temperature (>500 °C) and heat capacity, low vapor pressure and good thermal and physical properties at high temperatures [5].

#### 3.1. Air

The main advantages of air are both the wide range of operating temperatures and its low costs. Moreover, it is abundant, free, environmentally benign and easy to handle. But, it presents significant drawbacks, such as limited heat transfer properties and large pumping power due to the high pressure needed [13].

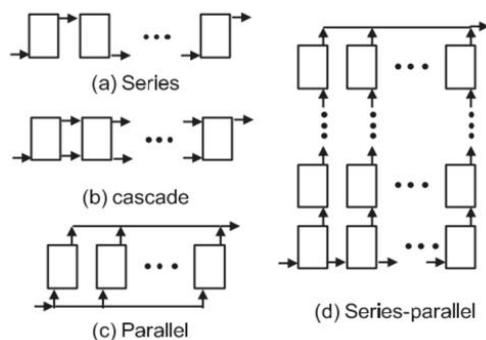

Figure 9. Basic arrangements of banks of solar collectors [12].

#### 3.2. Water/Steam

Water has good physical properties to be used as an HTF. The only drawback is that it may be unstable and difficult to manage at high temperatures or pressures. Water is chemically stable at a very high temperature, but, it undergoes a phase transition from liquid to vapor. The higher the pressure, the higher the saturation temperature at which evaporation occurs. It is more attractive to heat water than steam because of its higher density, specific heat capacity and thermal conductivity [13].

#### 3.3. Thermal Oils

CSP plants initially started using synthetic oil, most widely known under the brand names TherminolVP-1 or Dowtherm A, in order to avoid the high-pressure requirement and phase transition when using water. This synthetic organic fluid can operate at a temperature up to 400°C to collect and transport heat in CSP applications.

When it is heated above 400 °C, the hydrocarbons break down quickly and hydrogen is produced. Degradation can reduce overall fluid lifetime and cause a build-up of sludge that reduces the system thermal efficiency and increases maintenance costs [7].

#### 3.4. Molten Salts

When the operating temperature of the system exceeds oil temperature limit (400°C), molten salts are preferred as HTF and heat storage medium. They have high volumetric heat capacity, high boiling point, and very high thermal stability. Their vapor pressure is near zero. The highest operating limit for molten salts is around 565°C. They are cheap, easily available, non-toxic and non-flammable. However, there are few problems with molten salts. Salts have a high melting point usually above 200°C which results in freezing in pipelines when there is no heat source. It is desirable to have a melting point close to the ambient temperature and a very high boiling point so that the HTF can operate at the maximum range [15]. Solar salt, Hitec and Hitec XL are three well-known types of molten salts. The solar salt composition, expressed in mass fractions, is 60wt% NaNO<sub>3</sub> + 40wt% KNO<sub>3</sub> and it may be used in the entire operating temperature range of 260°C to 600°C. Hitec is a ternary molten salt whose composition, expressed in mass fractions, is 53wt% KNO<sub>3</sub> + 40wt% NaNO<sub>2</sub> + 7wt% NaNO<sub>3</sub>. It is liquid and stable in the range 142–535 °C. Hitec XL is also a ternary molten salt whose composition is 45wt% KNO<sub>3</sub> + 48wt% Ca(NO<sub>3</sub>)<sub>2</sub> + 7wt%

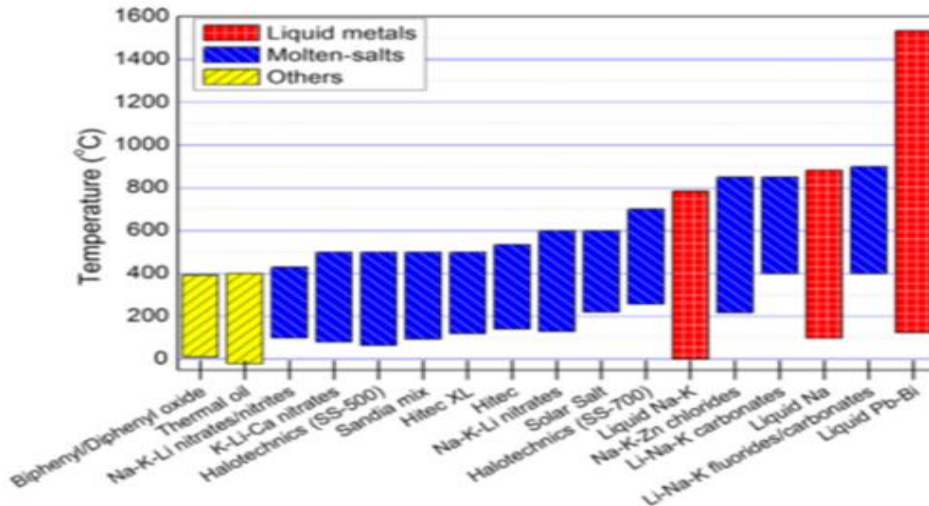

Figure 10. Operating temperature range for various HTFs [5].

NaNO<sub>3</sub>. It is liquid and stable in the temperature range of 130-550°C. Table 2 presents these molten salts and their properties [13, 15].

	Solar Salt	Hitec	Hitec XL
Max. operation temp. (°C)	585	450-538	480-505
Specific heat (J/kg.°C) @ 300 °C	1495	1560	1447
Density (kg/m <sup>3</sup> ) @ 300 °C	1899	1860	1992
Max. operation temp. (°C)	585	450-538	480-505
Viscosity (cp) @ 300 °C	3.26	3.16	6.37
Thermal conductivity (W/m.K)	0.55	0.6	0.519
Cost (\$/kg)	1.3	1.93	1.66

### 3.5. Liquid Metals

Liquid metals are currently being studied for use in solar thermal systems as HTFs and thermal energy storage. they have several promising properties of extensive operating temperature range, low viscosity, and efficient heat transfer characteristics. For example, liquid sodium has an

operating temperature range of 98-883°C [5]. Costs of these liquid metals are relatively higher than that of molten salt or water/steam HTFs. In addition, heat capacities of the liquid metals are almost lower than commercial nitrate/nitrite-based salts and therefore, they are less favorable to be used as HTF [16].

### 4. Thermal Energy Storage (TES) System

The main drawback of solar power is its temporal intermittency. To overcome this problem, one solution is to use a backup system (energy hybridization) that burns fossil fuel or biomass. A second solution is to use a thermal energy storage (TES) system to store heat during sunshine hours and release it during the periods of weak or no solar irradiation [18]. A TES system mainly consists of three main parts of the storage medium, heat transfer mechanism, and a containment system. The TES medium stores the thermal energy either in the form of sensible heat, latent heat of fusion or vaporization, or in the form of reversible chemical reactions. The sensible heat materials in the form of synthetic oil and molten salt are the most widely used in large-scale CSP systems. The purpose of the energy transfer mechanism is to supply or extract heat from the storage medium. The containment system holds the storage medium and the energy transfer equipment while insulates the system from the surroundings [19].

Before selecting an appropriate TES system, a total analysis of all requirements need to be carried out. TES system should be compatible with all the other components in the plant. In addition, operational temperature range, number of the required hours of storage, charging and discharging

rate, integration with solar collection system etc should also be confirmed. Consequently, the best-suited storage material, heat exchanger between the thermal storage material and HTF etc. should be chosen [20].

#### 4.1. Classification of TES Technologies

TES systems can be categorized as “active” or “passive”. When the storage medium is a fluid and is able to flow between the tanks, the systems are called “active”. If the storage medium is also used as the heat transfer fluid, the system is called “direct-active” system. When the storage fluid and heat transfer fluid are different, an additional heat exchanger is needed and the unit is called as “indirect-active” type. In cases where the storage medium is solid, the HTF passes through the storage medium only for charging and discharging. Such a system is called “passive”. Fig. 11 shows the various TES system configurations [19]. TES systems can be broadly classified into three classes including sensible heat, latent heat and thermochemical heat storage [15, 19, 21].

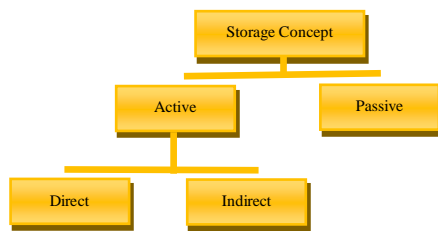

Figure 11. Classification scheme of different storage systems according to the storage concept [17].

##### 4.1.1. Sensible Heat TES System

In the sensible heat storage systems, thermal energy is stored/released by raising/decreasing the temperature of a storage material. It is a purely physical process without any phase change during charge or discharge. Therefore, the amount of heat stored depends on the product of the mass, specific heat, and temperature variation of the storage material [18]. Some of the TES systems of this type are as follows.

##### 4.1.1.1. Two-Tanks Direct Active System

In this type (Fig. 12), an HTF like thermal oil or molten salt acts as both HTF and a thermal storage medium. So, an intermediate heat exchanger is not required. One tank is used as a hot tank with a higher temperature and the other is used as a cold tank where the temperature is around 60 to 100°C less. The HTF flows from the hot tank to power block where it discharges the heat power and then flows back to the cold tank. During the daytime, the HTF from cold storage tank flows to the solar

field and gets heated and flows back into the hot tank. The operation of this type of TES system has some limitations in high temperatures because of the high vapor pressure of the HTF [15].

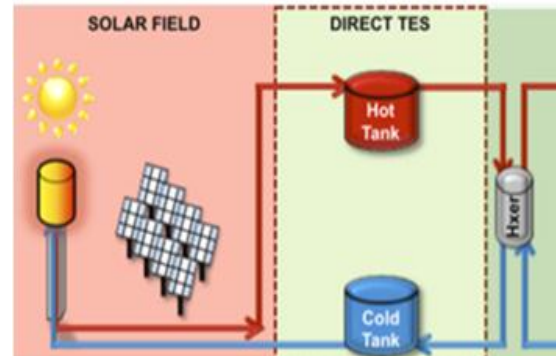

Figure 12. Two-tanks direct TES system integrated into a CSP plant [21]

##### 4.1.1.2. Two-Tanks Indirect Active System

In this type, an HTF like steam or mineral oil acts as HTF and molten salt acts as a thermal storage medium (Fig. 13). Generally, PTC plants use the indirect storage approach, where the cold molten salt is heated up in the heat exchanger by the oil-type HTF delivered from the solar field [21]. This type of TES system is implemented at Andasol-1 solar power plant located in Guadix, Granada, Spain. The storage capacity of this solar power plant is about 1,010 MW h, that means about 7.5 h of full-load production of electricity [22].

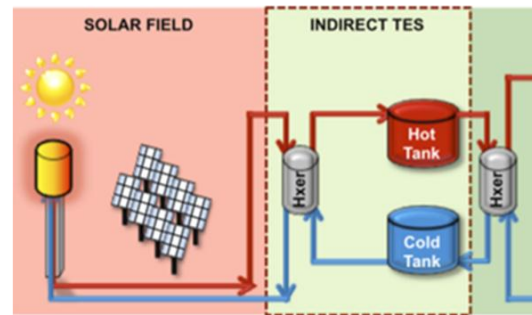

Figure 13. Two-tanks indirect TES system integrated into a CSP plant [21].

##### 4.1.1.3. Single-Tank Thermocline System

A single-tank thermocline storage, which eliminates one tank, enables a potential cost reduction of 35% compared to the two-tank storage system [21]. In single-tank, a thermal gradient is created within the storage tank due to the buoyancy effect. An effective separation between the hot fluid at the top and cold fluid at the bottom is also maintained. As the hot storage fluid is pumped at the top, it displaces the cold fluid towards down and remains on top. A system where the whole thermocline tank is filled with liquid storage



medium is an active thermocline system. To reduce the relatively expensive liquid storage medium requirement, a low-cost solid filler material which is compatible with the liquid storage medium is used to fill most of the volume in the thermocline tank (Fig. 14). Therefore, when the solid filler is used as primary thermal storage material is a passive system. The liquid storage medium usually will be molten salts and solid filler material will be such as quartzite rock [15, 23].

#### 4.1.1.4. Steam Accumulators

A steam accumulator consists of a steel pressure tank designed to resist high pressure and high-temperature water/steam. Fig. 15 shows a schematic view of a steam accumulator with its internal components [17]. In this system, water is converted to steam at the solar receiver system, and the excess steam during off-peak hours is stored at high pressure up to 100 bar in steam accumulators. At this pressure, steam is stored in the liquid phase with a high volumetric heat capacity of water up to  $1.2 \text{ kWh/m}^3$ . This is a simple and low-cost system with the benefits of water as a storage medium. But, this system has also some issues like increased piping cost due to high vapor pressure, instability of two-phase flow inside the receiver tubes and a need for the auxiliary protective heating system during startup [15].

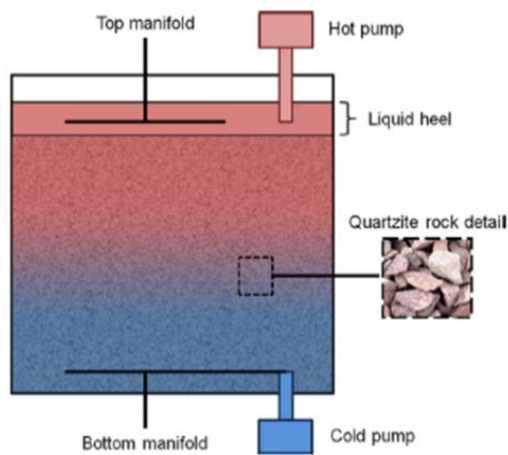

Figure 14. Schematic view of a molten-salt thermocline tank, including the porous quartzite rock bed and the liquid heel [21].

#### 4.1.2. Latent heat TES system

In a latent heat storage system, thermal energy is stored or released by a phase changing material (PCM) at a constant temperature [18]. PCMs can store or release a large amount of heat when reforming their phase structures during melting and solidification processes. Since the phase transition enthalpy of PCMs is usually much higher than sensible heat (100-200), latent heat storage has

much higher storage density than sensible heat storage. Some of PCMs have phase change temperatures ranging from  $100^\circ\text{C}$  to  $897^\circ\text{C}$ , and latent heat ranging from 124 to  $560 \text{ kJ/kg}$  [14]. Due to high-temperature requirements for CSP systems, inorganic salts/salt eutectics and metals/metal alloys can be used as PCM. Salts have been the most studied PCMs to reduce the cost of thermal storage [21]. Some of the commercial PCMs have been shown in Table 3.

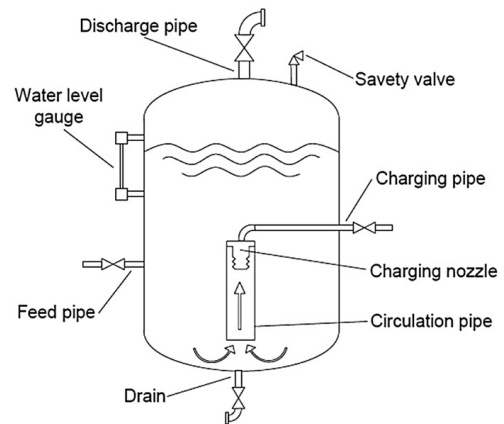

Figure 15. Variable-pressure steam accumulator [17].

The main problem with PCMs is their low thermal conductivity (usually  $0.2\text{--}0.8 \text{ W/m.k}$ ), resulting in very slow charge and discharge processes [24]. Remarkable efforts have been made to enhance the heat transfer within PCM storage systems, including extending the heat transfer surface by encapsulating the PCM or adding fins to the wall of the heat exchanger tubes, adding heat pipes or thermosiphons and composing high thermal conducting materials into the PCM, e.g. magnesium oxide and graphite. At present, no commercial PCM storage system has been used in utility-scale CSP applications [21].

#### 4.1.3. Thermochemical heat TES system

Thermochemical TES systems are based on reversible chemical reactions, which are characterized by a change in the molecular configuration of the reactants. Solar heat is used to drive an endothermic chemical reaction and then, stored in the form of chemical potential.

During the discharge, the stored heat can be recovered by the reversed exothermic reaction by adding a catalyst. The advantages of thermochemical storage are relying on their high energy density (up to 10 times greater than latent storage) and the significant long storage duration at ambient temperatures [18]. Metallic hydrides, carbonates system, hydroxides system, redox system, ammonia system, and the organic system can be used for thermochemical heat storage at

medium to a high-temperature range of 300-1000°C [18]. The studied processes include metal salts with water, ammonia, methanol or methyl-ammonia and metal alloys with hydrogen. Generally, chemical reaction allows the energy to be stored at over 400°C with a higher heat of reaction from 80 to 180 kJ/mol [25].

However, the application of chemical storage is limited because of these problems: complicated reactors requirements for specific chemical reactions, weak long-term durability (reversibility) and chemical stability [14]. The characteristics of a number of existing solar thermal power plants all over the world including power capacity, collector technology, heat transfer fluid, and TES system has been summarized in Table 4.

Storage material	Phase change temp. (°C)	Density (kg/m <sup>3</sup> )	Thermal conductivity (W/m.K)	Latent heat (kJ/kg)
RT100 (paraffin)	100	880	0.2	124
E117 (inorganic)	117	1450	0.7	169
A164 (organic)	164	1500	n.a.	306
NaNO <sub>3</sub>	307	2260	0.5	172
KNO <sub>3</sub>	333	2110	0.5	226
KOH	380	2044	0.5	149.7
MgCl <sub>2</sub>	714	2140	n.a.	452
NaCl	800	2160	5	492
LiF	850	n.a.	n.a.	n.a.
Na <sub>2</sub> CO <sub>3</sub>	854	2533	2	275.7
K <sub>2</sub> CO <sub>3</sub>	897	2290	2	235.8
KNO <sub>3</sub> -NaNO <sub>2</sub> -NaNO <sub>3</sub>	141	n.a.	n.a.	275
LiNO <sub>3</sub> -NaNO <sub>3</sub>	195	n.a.	n.a.	252
MgCl <sub>2</sub> -KCl-NaCl	380	2044	0.5	149.7

#### 4. Conclusions

The present study provides an investigation of various components of a solar field for producing required thermal power in a secondary application. Among the CSP systems, PTCs possess the greatest portion in commercial and industrial applications. In order to eliminate the fluctuations of receiving

solar energy and keep the efficiency of the solar system constant throughout the day and night, utilizing TES systems is necessary. There are three main classes of TES materials. In case of large size and high-temperature TES systems, sensible heat storage materials are the main materials.

In case of low temperature, PCMs are the main TES materials. Thermochemical heat storage materials are also in the laboratory stage and currently, have very limited practical applications. However, High initial capital cost requirement is the main impediment to implementation of TES systems. As was mentioned in Table 4, the combination of PTCs as solar collectors, thermal oils as HTFs and two-tank indirect storage as TES systems has been the first choice of experts in most of the solar thermal power plants all over the world. Increasing the efficiency of solar collectors and receivers, development of cheaper and more convective materials with higher specific heat as HTF and lowering the capital cost of TES systems with faster charging and discharging cycles and lower heat losses are the main issues of this field that needs to be further studied.

**Table 4. Some of existing solar thermal power plants all over the world [26, 27]**

Name of plant (power[MW])	Country	Technology used	Heat transfer fluid	TES system
Andasol solar power station (150)	Spain	PTC	Thermal oil (293-393 C)	7.5 h of heat storage, 2 tank indirect storage using molten salts
Palma del rio solar power station (100)	Spain	PTC	Diphenyl/Diphenyl oxide (293-393 C)	No storage
Helioenergy solar power station (100)	Spain	PTC	Thermal oil (293-393 C)	No storage, using fossil fuel as backup
La Florida (50)	Spain	PTC	Diphenyl/Diphenyl oxide (298-393 C)	7.5 h of heat storage, 2 tank indirect storage using molten salts
Puerto Errado2 (30)	Spain	LFR	Water (140-270 C)	0.5 h of heat storage, single tank thermocline
Solar energy generating systems (354)	USA	PTC	Therminol fluid (349-390 C)	N.a.
Nevada solar one (64)	USA	PTC	Dowtherm fluid	0.5 h of heat storage
Kimberlina solar thermal energy plant (5)	USA	LFR	Water	No storage
Maricopa solar (1.5)	USA	PDR	n.a.	No storage
Yazd integrated solar combined cycle power stations (17)	Iran	PTC	Thermal oil	No storage
Shiraz solar power plant (0.25)	Iran	PTC	Thermal oil	No storage, using fossil fuels in the night or cloudy times

### Nomenclature

CPC	Compound Parabolic Collector
CSP	Concentrating Solar Power
CST	Concentrated Solar Thermal
ETC	Evacuated Tube Collector
FPC	Flat Plate Collector
GHG	Greenhouse Gas
HE	Heat Exchanger
HTF	Heat Transfer Fluid
LFR	Linear Fresnel Reflector
ORC	Organic Rankine Cycle
PCM	Phase Change Material
PDR	Parabolic Dish Reflector
PTC	Parabolic Trough concentrator
PV	Photovoltaic
TES	Thermal Energy Storage

### References

- [1] A. Shahsavari and M. Akbari, "Potential of solar energy in developing countries for reducing energy-related emissions," *Renewable and Sustainable Energy Reviews*, vol. 90, pp. 275-291, 2018.
- [2] D. Fernández-González, Í. Ruiz-Bustanza, C. González-Gasca, J. Piñuela Noval, J. Mochón-Castaños, J. Sancho-Gorostiaga, *et al.*, "Concentrated solar energy applications in materials science and metallurgy," *Solar Energy*, vol. 170, pp. 520-540, 2018.
- [3] O. Aboelwafa, S.-E. K. Fateen, A. Soliman, and I. M. Ismail, "A review on solar Rankine cycles: Working fluids, applications, and cycle modifications," *Renewable and Sustainable Energy Reviews*, vol. 82, pp. 868-885, 2018.
- [4] E. Kabir, P. Kumar, S. Kumar, A. A. Adelodun, and K.-H. Kim, "Solar energy: Potential and future prospects," *Renewable and Sustainable Energy Reviews*, vol. 82, pp. 894-900, 2018.
- [5] K. Vignarooban, X. Xu, A. Arvay, K. Hsu, and A. M. Kannan, "Heat transfer fluids for concentrating solar power systems – A review," *Applied Energy*, vol. 146, pp. 383-396, 2015.
- [6] S. A. Kalogirou, "Solar thermal collectors and applications," *Progress in Energy and Combustion Science*, vol. 30, pp. 231-295, 2004.
- [7] M. Orosz and R. Dickes, "Solar thermal powered Organic Rankine Cycles," pp. 569-612, 2017.
- [8] Z. Su, S. Gu, and K. Vafai, "Modeling and simulation of ray tracing for compound parabolic thermal solar collector," *International Communications in Heat and Mass Transfer*, vol. 87, pp. 169-174, 2017.

- [9] S. A. Kalogirou, "A detailed thermal model of a parabolic trough collector receiver," *Energy*, vol. 48, pp. 298-306, 2012.
- [10] I. B. Askari and M. Ameri, "Solar Rankine Cycle (SRC) powered by Linear Fresnel solar field and integrated with Multi Effect Desalination (MED) system," *Renewable Energy*, vol. 117, pp. 52-70, 2018.
- [11] J. Coventry and C. Andraka, "Dish systems for CSP," *Solar Energy*, vol. 152, pp. 140-170, 2017.
- [12] M. Picón-Núñez, G. Martínez-Rodríguez, and A. L. Fuentes-Silva, "Design of solar collector networks for industrial applications," *Applied Thermal Engineering*, vol. 70, pp. 1238-1245, 2014.
- [13] H. Benoit, L. Spreafico, D. Gauthier, and G. Flamant, "Review of heat transfer fluids in tube-receivers used in concentrating solar thermal systems: Properties and heat transfer coefficients," *Renewable and Sustainable Energy Reviews*, vol. 55, pp. 298-315, 2016.
- [14] Y. Tian and C. Y. Zhao, "A review of solar collectors and thermal energy storage in solar thermal applications," *Applied Energy*, vol. 104, pp. 538-553, 2013.
- [15] G. Alva, Y. Lin, and G. Fang, "An overview of thermal energy storage systems," *Energy*, vol. 144, pp. 341-378, 2018.
- [16] J. Pacio, C. Singer, T. Wetzel, and R. Uhlig, "Thermodynamic evaluation of liquid metals as heat transfer fluids in concentrated solar power plants," *Applied Thermal Engineering*, vol. 60, pp. 295-302, 2013.
- [17] E. González-Roubaud, D. Pérez-Osorio, and C. Prieto, "Review of commercial thermal energy storage in concentrated solar power plants: Steam vs. molten salts," *Renewable and Sustainable Energy Reviews*, vol. 80, pp. 133-148, 2017.
- [18] U. Pelay, L. Luo, Y. Fan, D. Stitou, and M. Rood, "Thermal energy storage systems for concentrated solar power plants," *Renewable and Sustainable Energy Reviews*, vol. 79, pp. 82-100, 2017.
- [19] S. Kuravi, J. Trahan, D. Y. Goswami, M. M. Rahman, and E. K. Stefanakos, "Thermal energy storage technologies and systems for concentrating solar power plants," *Progress in Energy and Combustion Science*, vol. 39, pp. 285-319, 2013.
- [20] G. Alva, L. Liu, X. Huang, and G. Fang, "Thermal energy storage materials and systems for solar energy applications," *Renewable and Sustainable Energy Reviews*, vol. 68, pp. 693-706, 2017.
- [21] M. Liu, N. H. Steven Tay, S. Bell, M. Belusko, R. Jacob, G. Will, *et al.*, "Review on concentrating solar power plants and new developments in high temperature thermal energy storage technologies," *Renewable and Sustainable Energy Reviews*, vol. 53, pp. 1411-1432, 2016.
- [22] A. Gil, M. Medrano, I. Martorell, A. Lázaro, P. Dolado, B. Zalba, *et al.*, "State of the art on high temperature thermal energy storage for power generation. Part 1—Concepts, materials and modellization," *Renewable and Sustainable Energy Reviews*, vol. 14, pp. 31-55, 2010.
- [23] S. Thaker, A. Olufemi Oni, and A. Kumar, "Techno-economic evaluation of solar-based thermal energy storage systems," *Energy Conversion and Management*, vol. 153, pp. 423-434, 2017.
- [24] K. S. do Couto Aktay, R. Tamme, and H. Müller-Steinhagen, "Thermal conductivity of high-temperature multicomponent materials with phase change," *International Journal of Thermophysics*, vol. 29, pp. 678-692, 2008.
- [25] J. Cot-Gores, A. Castell, and L. F. Cabeza, "Thermochemical energy storage and conversion: A-state-of-the-art review of the experimental research under practical conditions," *Renewable and Sustainable Energy Reviews*, vol. 16, pp. 5207-5224, 2012.
- [26] <https://solarpaces.nrel.gov>
- [27] <https://en.wikipedia.org>