

Improved Electromagnetic Compatibility Standards for the Interconnected Wireless World

Marc Pous
Grup de Compatibilitat
Electromagnètica,
Departament d'Enginyeria Electrònica
Universitat Politècnica de Catalunya
Barcelona, Spain
email: marc.pous@upc.edu

Marco A. Azpúrua
Grup de Compatibilitat
Electromagnètica,
Departament d'Enginyeria Electrònica
Universitat Politècnica de Catalunya
Barcelona, Spain
email: marco.azpurua@upc.edu

Ferran Silva
Grup de Compatibilitat
Electromagnètica,
Departament d'Enginyeria Electrònica
Universitat Politècnica de Catalunya
Barcelona, Spain
email: ferran.silva@upc.edu

Abstract— The future is wireless, a world where everything is interconnected. However, the current standards for ensuring the electromagnetic compatibility (EMC) and the coexistence of such wireless systems urge for a major update. It is shown how novel statistical approaches based on the amplitude probability distribution detector and time-domain measurements are better suited for estimating the degradation caused by electromagnetic interferences on digital communication systems than the established practice of determining compliance according to the quasi-peak detector levels using a pass/fail criterion. Therefore, a redefinition of the test methods and of the compliance requirements in terms of EMC standards must be a priority of the international standardization bodies. Finally, a discussion of the fundamental challenges involved in this standardization breakthrough for EMC is delivered.

Keywords— *electromagnetic coexistence, electromagnetic compatibility, electromagnetic interference, wireless communications, standardization.*

I. INTRODUCTION

Nowadays, wireless systems are fundamental to the progress of technology and society. For instance, major technology breakthroughs such as the smart cities [1], the smart grid [2], autonomous vehicles [3], the internet of things (IoT) [4] and, many others, heavily rely on wireless systems.

According to a forecast from Ericsson, by 2022 there will be 29 billion connected devices, of which around 18 billion will be related to IoT [5]. Such massive IoT connections are expected to be supported by the 5G network capabilities. As the number of connected devices rises, the electromagnetic environment increases its complexity and the radiofrequency spectrum is more and more populated. This means higher risks of encountering electromagnetic compatibility, interference and coexistence problems.

Nonetheless, electromagnetic compatibility (EMC) challenges are not, whatsoever, a new concern. There is a long history of awareness regarding the importance of protecting wireless communication systems and all their applications against radiated electromagnetic interference (EMI). Currently, there are many EMC standards and recommendations from the IEC, IEEE and the ITU addressing the testing methods and requirements that electronic equipment shall comply with to ensure that, when

used as intended, such equipment does not disturb radio and telecommunication, as well as other equipment.

In that sense, the International Special Committee on Radio Interference (CISPR) was created more than 80 years ago with the main objective of ensuring uniform testing methods and requirements for limiting unintentional electromagnetic disturbances.

Incredibly, although wireless communication systems have evolved from analog to complex digital systems, the testing methods for measuring electric and electronic equipment electromagnetic emissions remain mostly unchanged to protect the current communication systems.

In fact, the cornerstone of radiofrequency EMI measurements is the test receiver, a standardized instrument, which is intended to provide a consistent reading of the EMI spectrum using the weighting detectors like the quasi-peak. Accordingly, the earlier studies about interferences in analog radiofrequency communication found a relationship between quasi-peak measurements and the quality of the received signal according to subjective human perception. Henceforth, the quasi-peak detector is used to define maximum admissible levels of emissions in EMC standards.

However, at the moment, most wireless communication systems are digital, and the quality of transmission is ensured in terms of the bit/frame error rate, packet loss, and throughput, among others.

Therefore, the question is if it is still reasonable to define EMC regulations based on the needle's mechanical behavior of the first-generation measuring receivers. Indeed, we will attempt to argue in this article that the interconnected wireless world challenges the standard practices and require us to update the methodology used to protect the wireless systems while mitigating the risk due to electromagnetic interference.

On the one hand, this paper objective is to demonstrate quasi-peak measurements are not representative for protecting wireless communications, thus new EMI testing approaches and requirements are needed. On the other hand, it is shown through a literature review and actual experimental results that there is enough evidence to support the usage of time-domain techniques and statistical detectors, such as the Amplitude Probability Distribution (APD), in EMI testing.

II. EMI MEASUREMENTS TO PROTECT WIRELESS COMMUNICATION SYSTEMS

A. Obsolete Detectors in Standard EMI Testing

At present, conducted and radiated electromagnetic emissions are evaluated in the frequency domain by measuring the interference using the quasi-peak (QP) and average detectors. Those standard detectors weight the level and the repeatability interferences for a given frequency range and fixed resolution bandwidth. To complete the assessment, the disturbance voltage or electric field measured is compared with a limit line for determining the compliance based on a pass/fail criterion. However, such detectors, resolution bandwidth and the limit lines employed were defined to protect analog communication systems that are not used anymore.

From the 30s early studies, the QP measurement of EMI was related to the quality of broadcasting reception, considering only the past-existing communication amplitude modulated analog narrowband systems. Thus, all the exhaustive studies were done correlating the QP measurements with the quality of the reception. The criterion was that 40 dB of signal-to-noise ratio was required for speech communications when an 80% modulation index was considered for a 9 kHz channel [6][7].

In 2018, we are still using the QP detector to measure EMI with the aim to protect the modern communication systems. Hence, for instance, it is not feasible to measure EMI with QP detector and predict the degradation over a Digital Video Broadcasting-Terrestrial (DVB-T) system which employs 7.2 MHz channels with OFDM modulation or a GSM digital communication system employing GMSK modulation [8], [9]. Up-to-date digital communications, used by the IoT or 5G devices, are further away from those narrowband communication channels when the QP detector was developed.

In fact, the main problem is that it is not possible to relate the weighting detectors measurement with the main figures of merit for Digital Communication Systems (DCS), which is the bit-error-probability (BEP). Several studies have tried to associate BEP with the output of different weighting detectors or a combination of the detectors [10][11] with little to no real success.

Furthermore, some industries, like those in the automotive or aerospace sectors, are not using QP detector in their standards as they consider interferences can be underestimated. However, they are currently employing Peak detector measurements, which is certainly a worst-case scenario, which produces an overestimation of the actual electromagnetic disturbances produced on DCS.

B. APD: A Statistical Approach

Obtaining the statistics of impulsive or transient interferences is the key to characterize, classify and model disturbances. In that sense, the amplitude probability distribution (ADP) is a relevant measure. Some of the pioneering research of the APD detector can be found in papers by Shepherd and Spaulding [12], [13] in the 1970s. Currently, the APD detector is defined in the latest edition of

CISPR 16-1-1 and its intended to be applied for frequencies above 1 GHz.

In that sense, the APD detector is defined as the part of the time the measured envelope of an interfering signal exceeds a certain level [10]. The relation between the $APD_R(r)$ and the probability density function of the envelope R is

$$APD_R(r) = 1 - F_R(r) \quad (1)$$

and

$$f_R(r) = \frac{d}{dr} F_R(r) = -\frac{d}{dr} APD_R(r) \quad (2)$$

where $F_R(r)$ is the cumulative distribution function (cdf) and $f_R(r)$ is the probability density function (pdf). Thus, the APD is directly obtained from the expressions shown in (1) and (2), and the more accurate pdf of the disturbance, a better EMC assessment. The APD detector output is represented in APD diagrams, a plot with the percentage of time the ordinate is exceeded on the y-axis and the envelope values on the x-axis.

In this regard, several studies published over the last decade have confirmed that ADP detector measurements can be effectively correlated with the DCS performance [14]-[18]. These studies also remark the possibility to implement limit lines or points at the APD diagrams according to the specifications of the DCS to be protected. Considering parameters like the sensibility, the modulation scheme, and the channel frequency band, such APD limits ensure proper performance of the DCS.

Fortunately, nowadays with the advanced capabilities of the measurement instruments and the post-processing techniques developed for time-domain EMI measurements, it is possible to compute the APD diagram at different frequency bands from a single capture [16], or by using real-time spectrum analyzers with the appropriate configuration [19].

Moreover, it is plausible, and even recommendable, to extend the working frequency range of the APD measurements below 1 GHz substituting conventional weighting detectors such us the QP. Hence, we could move from QP measurements based on mechanical constants, which are uncorrelated with the DCS performance, to a measurement solution that is, indeed, already included in CISPR-16-1-1, allowing us to find out the BEP.

III. CASE STUDY

This section presents a proof-of-concept experiment intended to show how meaningful would be embracing and statistical approach for EMI measurements. Consequently, the EMI is evaluated using the APD detector and the conventional weighting detectors. Comparisons and analysis are performed.

A. Measurement set-up

The case study is based on electromagnetic emissions assessed at an ISM frequency band where the final user can define the communication systems suitable for them,

respecting the center frequency and the bandwidth. The ISM frequency band under study is the band defined at 40.68 MHz with a bandwidth of 400 kHz. Note that, as the majority of the DCS, the bandwidth of the system is different from the 120 kHz defined at the C-Band of EMC standards.

Regarding the noise measured, it is a Gaussian broadband noise gated according to different repetition frequencies. This noise simulates a broadband EMI or type A Middleton noise [20], which is a realistic noise interference broadly studied by ITU-T as it causes malfunctions to communication systems [10]. In the next sections, we measure the synthesized interference according to current EMC emissions standards and the proposed APD approach.

Fig. 1 shows the test setup. Here, an arbitrary waveform generator (AWG) produces Gaussian noise with an amplitude of 50 mV as a broadband interference from DC to 330 MHz. The CH1 output of the AWG is connected to the input of an RF Mini-Circuits switch model ZSWA-4-30DR. This switch performs the gating of the Gaussian noise by using a pulsed signal generated by the second channel (CH2) of the AWG. The repetition frequency of the pulsed signal is set to 1 kHz and its duration is varied according to Table I. The intention of this experiment is to generate interferences that occupy the communication channel for controlled time intervals.

The generated interference signal is then measured using two different types of receivers. First, using a standard super-heterodyne test receiver with a fixed IF filter bank (only capable of measuring with the standard RBW, that is, 200 Hz, 9 kHz, 120 kHz, 1 MHz) and, secondly, with a Time-Domain based receiver capable of obtaining the faster APD diagrams with the exact RBW equal to the bandwidth of the communication system, which in this case is 400 kHz.

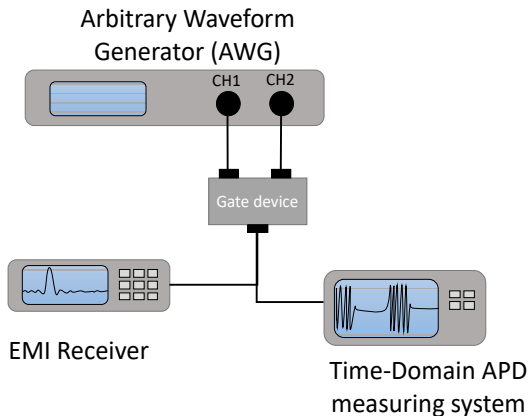

Fig. 1. Test setup of the proof-of-concept experiment.

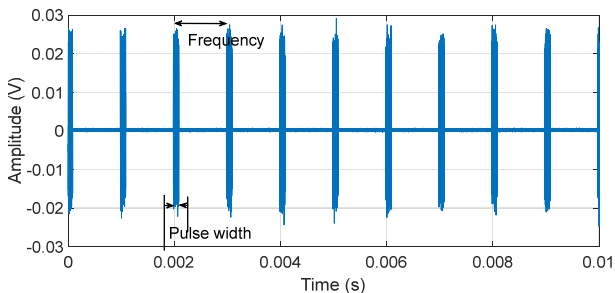

Fig. 2. Time-domain signal of the gated white Gaussian noise when Int10 is generated.

TABLE I. GENERATED EMI TO BE EVALUATED

Reference	Interference parameters		
	Pulse width [μ s]	Frequency [kHz]	Channel occupancy [%]
Int100	1000	1	100
Int50	500	1	50
Int10	100	1	10
Int5	50	1	5
Int1	10	1	1
Int0.5	5	1	0,5
Int0.1	1	1	0,1

B. Traditional weighting detector results

Using conventional EMI receivers according to CISPR16-1-1 weighting detectors means to obtain a single value for each detector. The bandwidth of the intermediate frequency and the type of detector is defined by the frequency band that we are evaluating. In this case study, we want to protect the DCS working at 40.68 MHz. This ISM frequency band falls within the C-Band according to CISPR 16-1-1 standard, therefore the detector that must be employed is the 120 kHz quasi-peak. The results obtained measuring according to the CISPR16-1-1 standard are shown in Table II.

TABLE II. EMI MEASUREMENTS ACCORDING TO THE STANDARD WEIGHTING DETECTORS

Reference	Interference Channel Occupancy [%]	Quasi-peak [dB μ V]	Peak [dB μ V]
Int100	100	48.3	55.8
Int50	50	47.5	55.8
Int10	10	45.6	54.9
Int5	5	44.6	54.8
Int1	1	41.0	54.1
Int0.5	0,5	38.8	51.6
Int0.1	0,1	32.0	45

In Table II we show the results employing the QP detector and the Peak detector for the different interference. We observe that the weighting detector provides different record values when we change the channel occupancy with the gated White Gaussian Noise. However, this single-value result does not ponder sufficiently the different disturbances generated. For instance, when we vary channel occupancy between 10% to 1%, the change at the QP output is only 4.6 dB. This is a slight difference if we think that we are changing 10 times the channel interference. Moreover, we must consider that the typical uncertainty for EMC radiated emissions test is also around 4 dB, which is the same difference found when we increase or decrease 10 times the distortion at the communication channel. In fact, our traditional EMI measurements are inaccurate and maybe this was not a problem because QP detector output can be valid for narrowband analog communication systems, which are based on SNR.

However, it is not enough to evaluate interferences for the modern digital communication systems if we consider the pass-fail limit line defined at the standards is not capable of distinguishing interferences with 100% to 5% channel occupancy. The outcome is undeniable over or underestimation of interferences impact. Conversely, we will

see that the usage of APD diagram will reduce the impact of the random component of the EMI in the measurement uncertainty as we move from a single QP output value to getting the statistics of the interference.

C. APD measurement approach

Using the previously described set-up we perform the APD measurements for the different interferences defined in Table I. It is important to highlight that the RBW employed in this occasion is equal to the bandwidth of the communication system, and this is the reason why the maximum values at the x-axes are higher than the ones obtained in Table II with the peak detector.

Fig. 3 shows the shape of all APD diagrams is fitting a heavy-tailed distribution, which is characteristic of impulsive noise. The changes in the shape of the APD diagram are directly related to the channel occupancy of the interference. Now, it becomes clear the difference in terms of probability the influence of channel occupancy. Therefore, it is possible to estimate the degradation that the different disturbances will cause to the DCS allocated at the 40.68 MHz ISM frequency band.

Furthermore, the possibility to compute limit points in the APD diagram according to the sensibility, the BER requirements and the modulation scheme of the communication system makes extremely easy to evaluate interferences. Relating the disturbances to the BER defined by the QoS requirements and determining if interferences will cause communication system malfunctions.

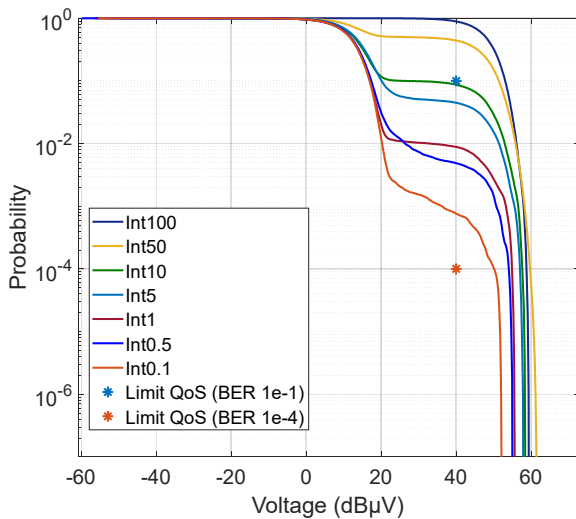

Fig 3. APD diagram obtained from measuring Table I interferences.

In Fig. 3, limit points have been added limiting at BEP of 10^{-1} and 10^{-4} , depending on the final application of the communication system and its associated QoS. Therefore, contrary to the current weighting detectors, with the APD diagram results, we can unequivocally determine the disturbance created by any disturbance to the DCS. Determining that Int100, Int50 will cause interference for both QoS limits defined and Int10, Int5, Int1, Int0.5, Int0.1 only for QoS associated with maximum 10^{-1} BER. However,

an intensive standardization process is required to protect the wireless communication systems.

IV. STANDARDIZATION CHALLENGES

A. Changing the paradigm of EMC testing

Fig. 4 shows the number of research papers covering the topics of time-domain and APD EMI measurements. This reflects an increasingly aware academic community regarding the situation described. From the authors' experience, we can attest that most researchers in the field of EMC very much agree with the need for a change of paradigm regarding EMC standardization for the protection of the wireless devices. Nonetheless, EMC test houses will keep practicing the standard procedures, even if they are not suitable anymore because they need to be compliant and deliver a service to the end customer.

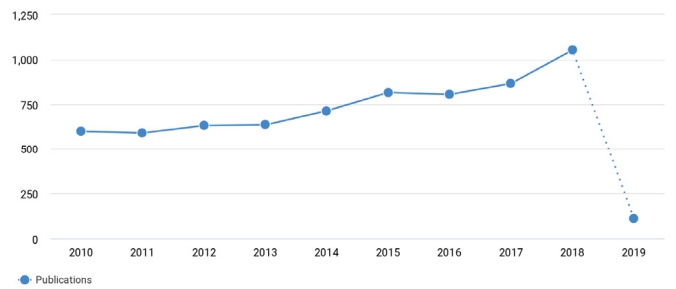

Fig 4. The number of papers per year with the keywords {"Time Domain" OR "APD" OR "Amplitude Probability Distribution"} AND {"EMI" OR "Electromagnetic Interference"}. Source <https://app.dimensions.ai>. Exported February 15, 2019.

Consequently, the first challenge is to reach technical committees and working groups in the corresponding standardization bodies to make them aware of the urgency of updating the emissions testing standards. They must begin the migration from current measurement practices based on the weighting detectors to new time-domain enabled statistical measurements that allow protecting unequivocally the new wireless devices, with special emphasis in the sensible low-power-low-cost transceivers used for IoT applications.

Therefore, the EMI measurement procedures, the new instrumentation requirements and the characteristics of the communication system must be analyzed for determining new suitable test requirements. Some of the key premises in this change of paradigm are:

- Promoting the worldwide homogeneity of the communication systems and of the spectrum allocation scheme to increase interoperability between different nations and improve the regulation and to achieve more general testing standards.
- Defining the requirements for communication systems in terms of the intended electromagnetic environment and the quality of service (QoS) required for the specific application developed in such scenarios.
- Getting the statistics of the interference should be made mandatory to evaluate the performance degradation of the communication system based on the abovementioned requirements.

- The output of the detector should use the frequency band defined by the communication system. Using the same measurement bandwidth of the communication system is fundamental, otherwise, huge deviation takes place for impulsive noise. Therefore, we should move from the 9 kHz, 120 kHz or 1 MHz predefined resolution bandwidths and apply the bandwidth of the allocated communication system.

B. The pursuit of an agile standardization process

For reforming the foundations of EMC testing and its enormous legacy of standards it is fundamental that several international standardization bodies define a more agile and interrelated work process. This means that institutions, technical committees, and working groups should improve their cooperation, commitment, and involvement to build up a full standardization scheme relevant to the protection of forthcoming and current wireless communication systems.

Fig. 5 shows a diagram in where telecommunication standardization bodies, international organizations with competences in EMC standardization and, other actors interact closely for updating the EMI measurements and testing standards in diverse application domains, comprising the healthcare, automotive, railway, and any other critical sector.

The International Telecommunication Union (ITU), and the European Telecommunications Standards Institute (ETSI) or even the 3GPP (3rd Generation Partnership Project) and the Wi-Fi Alliance, among others, are responsible for defining wireless communication systems. Such communication systems have a broad field of application. For instance, Bluetooth or Wi-Fi can be applied to many industries (healthcare, railway, automotive, among others), each of them having different performance requirements. Conversely, the IEC, CISPR and ISO technical committees (TC) or the IEEE working groups (WG) are responsible for setting the EMC requirements for protecting the wireless systems as well as the testing methods.

All the above-mentioned entities should work together and in a close interrelation to define the “smart” interference

limits needed to protect the wireless devices. And here “smart” means suitable for the application, representative of the electromagnetic environment and, directly related to QoS criteria.

C. Risk assessments rather than pass/fail statements

Currently, most of the standards only define two different electromagnetic emissions limits, one for residential and other for industrial environments. The electromagnetic disturbances measured with the standard weighting detectors can be only above or below the specified limit and, according to this simplistic analysis, a certain product is declared compliant or not with the EMI standards.

However, nowadays the performance requirement of the communication system and its importance is better determined by both the application and the environment. Applications are diverse and electromagnetic environments can be characterized for defining a satisfactory QoS requirement a reasonable risk assessment.

In that sense, the EMC engineers must think about what is important to protect. Is the intended application of the wireless system safety critical? What are the real electromagnetic threats the environment poses to a certain wireless system in terms of its communications technology and the QoS required for the intended application? How robust is the wireless system against intentional and unintentional interferences? Moreover, it is also important to think about how communications can be hardened according to the interferences characteristic of the environment in where the wireless systems are intended to be used.

This kind of risk assessments, even if they are harder to standardize, would deliver a lot more insights than a conventional test report. It is important that our future EMC standard take the lessons learned from the field of project and quality management to realize meaningful risk evaluations of the interferences emitted by the equipment under test rather than performing a simple compliance check, with little to none implications for managing EMC risks.

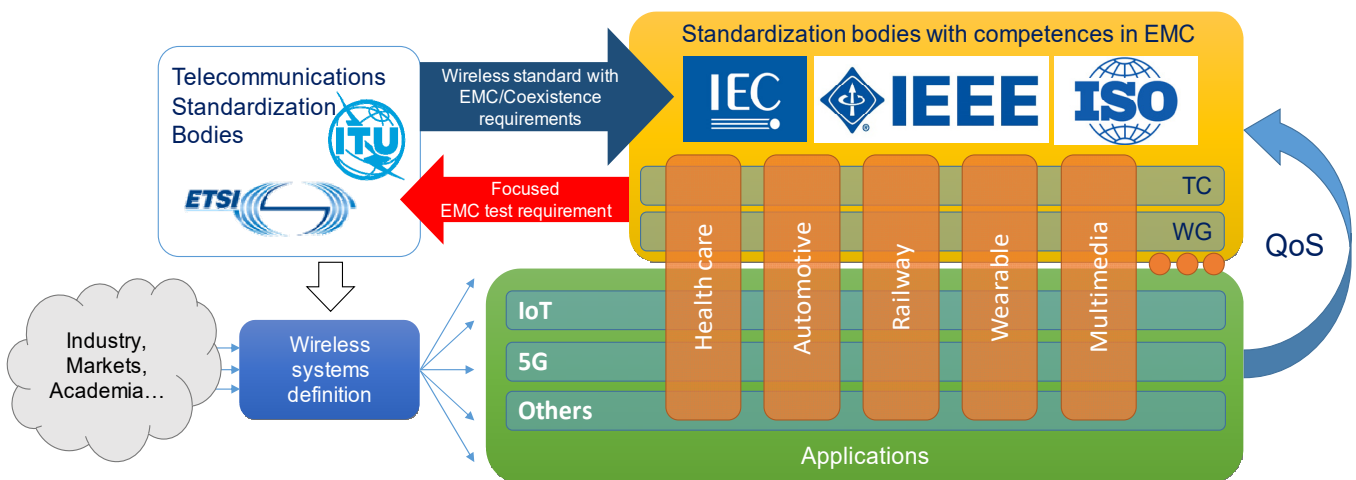

Fig 5. Diagram of the interrelation between wireless telecommunication drivers and the standardization bodies involved in defining the EMC related testing and measurement methods.

V. CONCLUSIONS AND DISCUSSION

Contemporary EMI measurement technology based on time-domain techniques enable fast, easy and, meaningful APD assessments. Embracing the proposed test methodology would allow for an accurate and comprehensive estimation of the BER produced by a certain EMI to a variety of wireless communication systems considering the influence of the electromagnetic environment into a specific wireless application. Consequently, an objective analysis of the impact of the electromagnetic emissions of the equipment under test can be performed, avoiding the underestimations or overestimations made with the current standardized practices. Moreover, adopting a statistical criterion to the evaluation of EMI would also mean a departure from the traditional deterministic approach characterized to deliver very imprecise measurements of the radiated electromagnetic fields with uncertainties typically higher than 4 dB. This would be beneficial for the manufacturers and for all the wireless applications encountered in the forthcoming interconnected world since APD test results can be directly related to QoS requirements, test reliability and EMI risk assessments.

However, even if the APD approach provides the tools for estimating the performance of DCS, it is still necessary that institutions like ITU, ETSI, IEC and many others involved in the telecommunications industry, work together to define the limits for the communication systems and the reserved bands considering the final application. As we show in this paper, nowadays, it is nonsensical to state EMI compliance based on limit lines defined for protecting amplitude modulated analog communications in industrial or residential environments. Conversely, all studies agreed in that for protecting wireless systems it is necessary to employ the statistical detectors and characterize properly the interference.

In this regard, standards must also consider the final application of the wireless system for defining the tolerable BER as different applications have different requirements of QoS. In fact, this is more relevant than ever has been because in the forthcoming years the world will be completely interconnected with IoT devices everywhere. Therefore, standards must be updated to define the proper evaluation methodologies that will ensure wireless systems are protected in a society that relies more and more on complex and interconnected electronic devices.

Of course, the authors acknowledge this is a major challenge for the standardization community that first must embrace a change of paradigm, then shall define a more agile, coherent and interactive standardization process suitable for, finally, reaching the breakthrough that will mean leaving behind the legacy of the pass/fail EMI testing and compliance approach for a modern, statistically supported and, objective scheme that includes application oriented EMI risk assessments.

REFERENCES

- [1] H. Zhu *et al.*, "Review of state-of-the-art wireless technologies and applications in smart cities," *IECON 2017 - 43rd Annual Conference of the IEEE Industrial Electronics Society*, Beijing, 2017, pp. 6187-6192.
- [2] K. Gai, M. Qiu, Z. Ming, H. Zhao and L. Qiu, "Spoofing-Jamming Attack Strategy Using Optimal Power Distributions in Wireless Smart Grid Networks," in *IEEE Transactions on Smart Grid*, vol. 8, no. 5, pp. 2431-2439, Sept. 2017.
- [3] L. Kong, M. K. Khan, F. Wu, G. Chen, and P. Zeng, "Millimeter-Wave Wireless Communications for IoT-Cloud Supported Autonomous Vehicles: Overview, Design, and Challenges," in *IEEE Communications Magazine*, vol. 55, no. 1, pp. 62-68, January 2017.
- [4] S. Pattar, R. Buyya, K. R. Venugopal, S. S. Iyengar, and L. M. Patnaik, "Searching for the IoT Resources: Fundamentals, Requirements, Comprehensive Review and Future Directions," in *IEEE Communications Surveys & Tutorials*.
- [5] Ericsson. "Internet of Things forecast". The *Ericsson Mobility Report*, June 2017. Available at: <https://www.ericsson.com/en/mobility-report/internet-of-things-forecast>.
- [6] A. J. Gill and S. Whitehead, "Electrical interference with radio reception," in *Electrical Engineers, Journal of the Institution of*, vol. 83, no. 501, pp. 345-386, September 1938
- [7] G. A. Jackson, "The early history of radio interference," in *Electronic and Radio Engineers, Journal of the Institution of*, vol. 57, no. 6, pp. 244-250, November-December 1987.
- [8] Wu, I., et al., "Characteristics of Radiation Noise from an LED Lamp and Its Effect on the BER Performance of an OFDM System for DTTB," *IEEE Transactions on Electromagnetic Compatibility*, vol.56, no.1, pp.132-142, Feb 2014
- [9] S. Dudoyer, et al., "Classification of Transient EM Noises Depending on their Effect on the Quality of GSM-R Reception," *IEEE Transactions on Electromagnetic Compatibility*, vol.55, no.5, pp.867,874, Oct. 2013
- [10] P. F. Stenumgaard, "Using the root-mean-square detector for weighting of disturbances according to its effect on digital communication services," in *IEEE Transactions on Electromagnetic Compatibility*, vol. 42, no. 4, pp. 368-375, Nov 2000.
- [11] M. Stecher, "A weighting detector for the effect of interference on digital radiocommunication services," *Electromagnetic Compatibility, 2003. EMC '03. 2003 IEEE International Symposium on*, Istanbul, 2003, pp. 449-452 Vol.1.
- [12] R. A. Shepherd, "Measurements of amplitude probability distributions and power of automobile ignition noise at HF," in *IEEE Transactions on Vehicular Technology*, vol. 23, no. 3, pp. 72-83, Aug. 1974.
- [13] A.D. Spaulding and R.T Disney. Man-Made Noise: Estimates for Business, Residential and Rural Areas. Technical report, Office of Telecommunications, 1976.
- [14] K. Wiklundh, "Relation between the amplitude probability distribution of an interfering signal and its impact on digital radio receivers," in *IEEE Transactions on Electromagnetic Compatibility*, vol. 48, no. 3, pp. 537-544, 2006.
- [15] Y. Matsumoto, "On the Relation Between the Amplitude Probability Distribution of Noise and Bit Error Probability," *IEEE Transactions on Electromagnetic Compatibility*, vol.49, no.4, pp.940,941, Nov. 2007
- [16] M. Pous and F. Silva, "Full-Spectrum APD Measurement of Transient Interferences in Time Domain," in *IEEE Transactions on Electromagnetic Compatibility*, vol. 56, no. 6, pp. 1352-1360, 2014.
- [17] M. Pous, M. A. Azpúrua, and F. Silva, "Measurement and Evaluation Techniques to Estimate the Degradation Produced by the Radiated Transients Interference to the GSM System," in *IEEE Transactions on Electromagnetic Compatibility*, vol. 57, no. 6, pp. 1382-1390, 2015.
- [18] M. Pous and F. Silva, "Prediction of the impact of transient disturbances in real-time digital wireless communication systems," in *IEEE Electromagnetic Compatibility Magazine*, vol. 3, no. 3, pp. 76-83, 3rd Quarter 2014.
- [19] H. H. Slim, C. Hoffmann, S. Braun, and P. Russer, "A novel multichannel amplitude probability distribution for a time-domain EMI measurement system according to CISPR 16-1-1," *10th International Symposium on Electromagnetic Compatibility*, York, 2011, pp. 22-25.
- [20] D. Middleton, "Canonical and quasi-canonical probability models of Class A interference," *IEEE Transactions on Electromagnetic Compatibility*, vol. EMC-25, no. 2, pp. 76 103, May 1983.